

Cub Cadet[®]

OPERATOR'S MANUAL

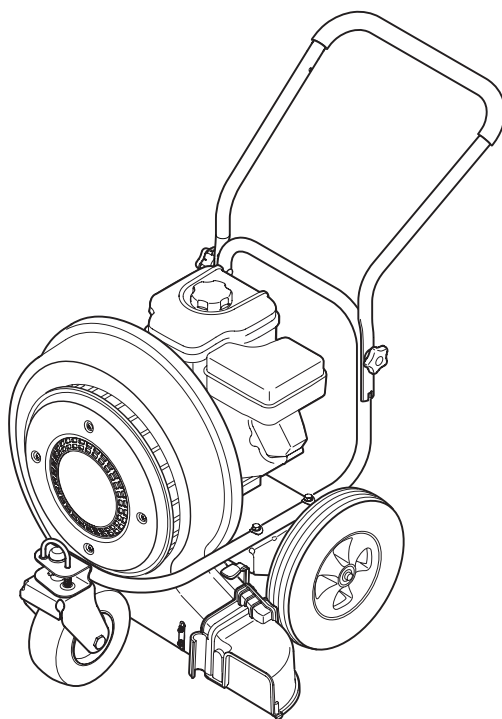

Jet Sweep Blower — JS 1150

⚠ WARNING

**READ AND FOLLOW ALL SAFETY RULES AND INSTRUCTIONS IN THIS MANUAL
BEFORE ATTEMPTING TO OPERATE THIS MACHINE.
FAILURE TO COMPLY WITH THESE INSTRUCTIONS MAY RESULT IN PERSONAL INJURY.**

CUB CADET LLC, P.O. BOX 361131 CLEVELAND, OHIO 44136-0019

Thank You

Thank you for purchasing a Cub Cadet Jet Sweep Blower. It was carefully engineered to provide excellent performance when properly operated and maintained.

Please read this entire manual prior to operating the equipment. It instructs you how to safely and easily set up, operate and maintain your machine. Please be sure that you, and any other persons who will operate the machine, carefully follow the recommended safety practices at all times. Failure to do so could result in personal injury or property damage.

All information in this manual is relative to the most recent product information available at the time of printing. Review this manual frequently to familiarize yourself with the machine, its features and operation. Please be aware that this Operator's Manual may cover a range of product specifications for various models. Characteristics and features discussed and/or illustrated in this manual may not be applicable to all models. We reserve the right to change product specifications, designs and equipment without notice and without incurring obligation.

If applicable, the power testing information used to establish the power rating of the engine equipped on this machine can be found at www.opei.org or the engine manufacturer's web site.

If you have any problems or questions concerning the machine, phone your local Cub Cadet dealer or contact us directly. Cub Cadet's Customer Support telephone numbers, website address and mailing address can be found on this page. We want to ensure your complete satisfaction at all times.

Throughout this manual, all references to *right* and *left* side of the machine are observed from the operating position.

Table of Contents

| | | | |
|---------------------------------------|----------|---|-----------|
| Safe Operation Practices | 3 | Maintenance & Adjustment | 10 |
| Assembly & Set-Up | 6 | Replacement Parts | 11 |
| Controls & Features..... | 8 | Warranty..... | 12 |
| Operation..... | 9 | | |

Record Product Information

Before setting up and operating your new equipment, please locate the model plate on the equipment and record the information in the provided area to the right. You can locate the model plate on the surface of the frame, on the rear of the machine. This information will be necessary, should you seek technical support via our web site, Customer Support Department, or with a local authorized service dealer.

MODEL NUMBER

| | | | | | | | | | | | |
|--|--|--|--|--|--|--|--|--|--|--|--|
| | | | | | | | | | | | |
|--|--|--|--|--|--|--|--|--|--|--|--|

SERIAL NUMBER

| | | | | | | | | | | | |
|--|--|--|--|--|--|--|--|--|--|--|--|
| | | | | | | | | | | | |
|--|--|--|--|--|--|--|--|--|--|--|--|

Product Registration and Customer Support

Please register your product on our website, www.cubcadet.com.

If you have difficulty assembling this product or have any questions regarding the controls, operation, or maintenance of this machine, you can seek help from the experts. Choose from the options below:

- ◇ Visit us on the web at www.cubcadet.com



See How-to Maintenance and Parts Installation Videos at www.cubcadet.com/tutorials

- ◇ Call a Customer Support Representative at (800) 965-4CUB
- ◇ Locate your nearest Cub Cadet Dealer at (877) 282-8684
- ◇ Write to Cub Cadet LLC • P.O. Box 361131 • Cleveland, OH • 44136-0019



WARNING! This symbol points out important safety instructions which, if not followed, could endanger the personal safety and/or property of yourself and others. Read and follow all instructions in this manual before attempting to operate this machine. Failure to comply with these instructions may result in personal injury.

When you see this symbol. **HEED ITS WARNING!**

CALIFORNIA PROPOSITION 65



WARNING! Engine Exhaust, some of its constituents, and certain vehicle components contain or emit chemicals known to State of California to cause cancer and birth defects or other reproductive harm.



DANGER! This machine was built to be operated according to the safe operation practices in this manual. As with any type of power equipment, carelessness or error on the part of the operator can result in serious injury. This machine is capable of amputating fingers, hands, toes and feet and throwing debris. Failure to observe the following safety instructions could result in serious injury or death.

Operation

General Operation:

1. Read, understand, and follow all instructions on the machine and in the manual(s) before attempting to assemble and operate. Keep this manual in a safe place for future and regular reference and for ordering replacement parts.
2. Be familiar with all controls and their proper operation. Know how to stop the machine and disengage them quickly.
3. Never allow children under 14 years of age to operate this machine. Children 14 and over should read and understand the instructions and safe operation practices in this manual and on the machine and be trained and supervised by an adult.
4. This leaf blower is a powerful tool, not a plaything. Therefore, exercise extreme caution at all times. It has been designed to perform one job; to blow leaves. Do not use it for any other purpose.
5. Keep the area of operation clear of all persons, particularly small children and pets. Stop the engine when they enter the vicinity of the machine.
6. Always wear safety glasses or safety goggles during operation and while performing an adjustment or repair, to protect eyes from debris or foreign objects that may be thrown from machine.
7. Wear close fitting slacks and shirt. Shirt and slacks that cover the arms and legs are recommended. Do not wear loose fitting clothes or jewelry and secure hair so it is above shoulder level. They can be caught in moving parts.
8. Do not operate the machine while under the influence of alcohol or drugs.
9. Never place your hands or any part of your body or clothing near rotating parts. Keep clear of the discharge opening at all times. Never insert your hands, fingers, feet, or any other part of your body or clothing into the discharge or air intake openings as the rotating impeller inside the housing can cause serious injury.
10. Never operate machine without directional discharge chute and plastic impeller guard properly affixed to machine. These devices shield the operator from accidental contact with the rotating impeller.
11. Keep all guards and safety devices in place and operating properly.
12. Exercise caution when operating blower. Do not allow the directional discharge chute to point in the direction of bystanders or pets.

13. If your machine should start making an unusual noise or vibration, immediately stop the engine, disconnect the spark plug wire and move the wire away from the spark plug. Allow the machine to stop and perform the following steps:
 - a. Inspect for damage.
 - b. Repair or replace any damaged parts.
 - c. Check for any loose parts and tighten to assure continued safe operation.
14. Muffler and engine become hot and can cause a burn. Do not touch.
15. Do not allow leaves or other debris to build up on engine's muffler. The debris could ignite and cause a fire.
16. Do not operate engine if air cleaner or cover over carburetor air intake is removed, except for adjustment. Removal of such parts could create a fire hazard.
17. Only use accessories approved for this machine by the manufacturer. Read, understand, and follow all instructions provided with the approved accessory.
18. Only operate machine in daylight or good artificial light. Do not operate machine in dark areas where your vision may be impaired.
19. Never pick up or carry machine while the engine is running.
20. If situations occur which are not covered in this manual, use care and good judgment. Contact Customer Support for assistance or the name of the nearest service dealer.

Children

Tragic accidents can occur if the operator is not alert to the presence of small children. Children are often attracted to the blowing activity. Never assume that children will remain where you last saw them.

1. Keep children out of the work area and under the watchful eye of a responsible adult other than the operator.
2. Be alert and turn the machine off if a child enters the area.
3. Never allow children under the age of 14 to operate the leaf blower.

Service

Safe Handling Of Gasoline:

1. To avoid personal injury or property damage use extreme care in handling gasoline. Gasoline is extremely flammable and the vapors are explosive. Serious personal injury can occur when gasoline is spilled on yourself or your clothes which can ignite. Wash your skin and change clothes immediately.
2. Use only an approved gasoline container.
3. Never fill containers inside a vehicle or on a truck or trailer bed with a plastic liner. Always place containers on the ground away from your vehicle before filling.

4. Remove gas-powered equipment from the truck or trailer and refuel it on the ground. If this is not possible, then refuel such equipment on a trailer with a portable container, rather than from a gasoline dispenser nozzle.
5. Keep the nozzle in contact with the rim of the fuel tank or container opening at all times until fueling is complete. Do not use a nozzle lock-open device.
6. Extinguish all cigarettes, cigars, pipes and other sources of ignition.
7. Never fuel machine indoors because flammable vapors will accumulate in the area.
8. Never remove gas cap or add fuel while engine is hot or running. Allow engine to cool at least two minutes before refueling.
9. Never over fill fuel tank. Fill tank to no more than ½ inch below bottom of filler neck to provide for fuel expansion.
10. Replace gasoline cap and tighten securely.
11. If gasoline is spilled, wipe it off the engine and equipment. Move machine to another area. Wait five (5) minutes before starting engine.
12. Never store the machine or fuel container near an open flame, spark or pilot light as on a water heater, space heater, furnace, clothes dryer or other gas appliances.
13. To reduce fire hazard, keep mower free of grass, leaves, or other debris build-up. Clean up oil or fuel spillage and remove any fuel-soaked debris.
14. Allow a mower to cool at least five (5) minutes before storing.

General Service:

1. Never tamper with safety devices. Check their proper operation regularly.
2. Check all nuts, bolts and screws for proper tightness at frequent intervals to keep the machine in safe working condition. Also, visually inspect machine for any damage and repair, if needed.
3. Before cleaning, repairing, or inspecting, stop the engine and make certain the impeller and all moving parts have stopped. Disconnect the spark plug wire and ground it against the engine to prevent unintended starting.
4. Do not change the engine governor settings or overspeed the engine. The governor controls the maximum safe operating speed of the engine.
5. Maintain or replace safety and instruction labels, as necessary.
6. Follow this manual for safe loading, unloading, transporting, and storage of this machine.
7. Never store the machine or fuel container near an open flame, spark or pilot light such as on a water heater, furnace, clothes dryer, or other gas appliances.
8. Always refer to the operator's manual for proper instructions on off-season storage.
9. If the fuel tank has to be drained, do this outdoors.
10. Observe proper disposal laws and regulations for gas, oil, etc. to protect the environment.

11. According to the Consumer Products Safety Commission (CPSC) and the U.S. Environmental Protection Agency (EPA), this product has an *Average Useful Life* of seven (7) years, or 70 hours of operation. At the end of the *Average Useful Life* have the machine inspected annually by an authorized service dealer to ensure that all mechanical and safety systems are working properly and not worn excessively. Failure to do so can result in accidents, injuries or death.

Spark Arrestor





WARNING! This machine is equipped with an internal combustion engine and should not be used on or near any unimproved forest-covered, brush-covered or grass-covered land unless the engine's exhaust system is equipped with a spark arrestor meeting applicable local or state laws (if any).

If a spark arrestor is used, it should be maintained in effective working order by the operator. In the State of California the above is required by law (Section 4442 of the California Public Resources Code). Other states may have similar laws. Federal laws apply on federal lands.

A spark arrestor for the muffler is available through your nearest engine authorized service dealer or contact the service department, P.O. Box 361131 Cleveland, Ohio 44136-0019.

Safety Symbols

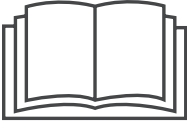
This page depicts and describes safety symbols that may appear on this product. Read, understand, and follow all instructions on the machine before attempting to assemble and operate.

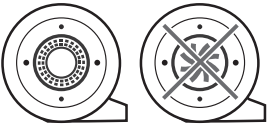
| Symbol | Description |
|---|---|
|  | READ THE OPERATOR'S MANUAL(S) Read, understand, and follow all instructions in the manual(s) before attempting to assemble and operate |
|  | WARNING— ROTATING BLADES Keep hands out of inlet and discharge openings while machine is running. There are rotating blades inside |
|  | BYSTANDERS Do not allow the directional discharge chute to point in the direction of bystanders or pets. |
|  | WARNING— SHIELDS AND GUARDS Never operate machine without directional discharge chute and plastic impeller guard properly affixed to machine. |



WARNING! Your Responsibility—Restrict the use of this power machine to persons who read, understand and follow the warnings and instructions in this manual and on the machine.

SAVE THESE INSTRUCTIONS!

Contents of Crate

- One Jet Sweep Blower
- One Upper Handle
- One Chute Attachment
- One Jet Sweep Blower Operator's Manual
- One Engine Operator's Manual
- One pair Safety Glasses

NOTE: All references to the left or right side of the jet sweep blower are from the operator's position. Any exceptions will be noted.

Assembly

Attaching the Upper Handle

1. Remove the carriage screws and star knobs from the upper holes in the lower handle. See Figure 3-1.

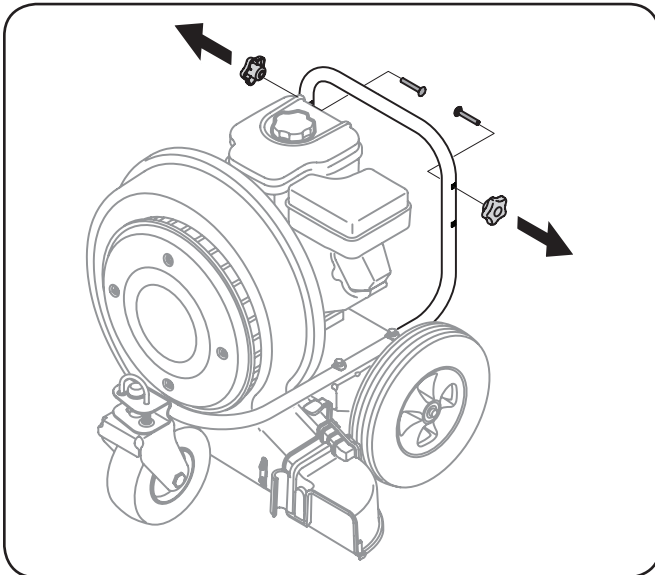

Figure 3-1

2. Place the upper over the lower handle, aligning the upper holes/metal tabs in the upper handle with the upper holes/lower holes in the lower handle. See Figure 3-2.

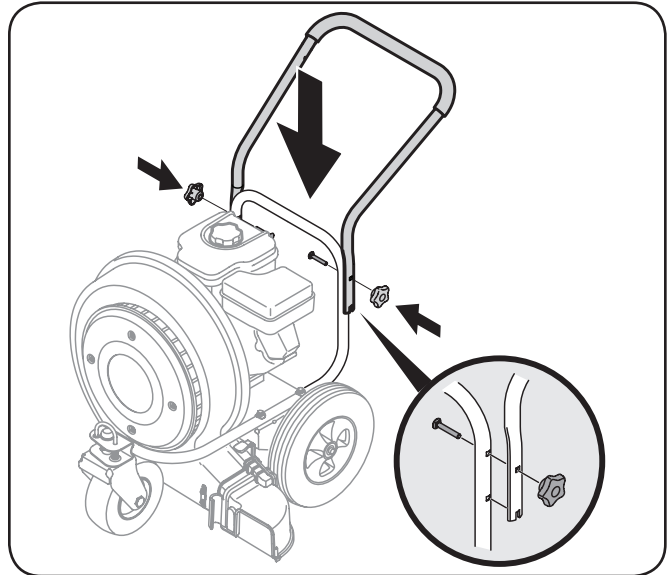

Figure 3-2

3. Secure with the carriage screws and star knobs removed earlier. See Figure 3-2.

Attaching the Chute Attachment



WARNING! DO NOT operate without shields and guards (e.g., discharge chute, air intake guard) in place.

To redirect airflow at a 90 degree angle during operation, a chute attachment is included with your jet sweep blower.

1. Pivot the blower direction lever all the way to the right, into the highest position. See Figure 3-3.

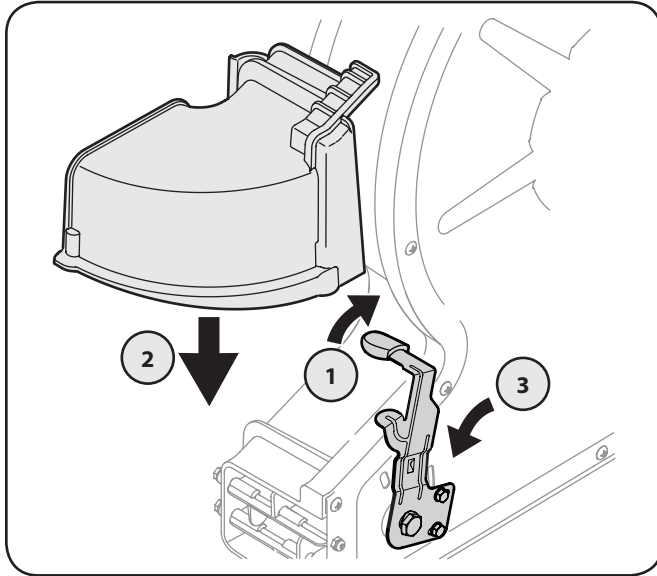

Figure 3-3

2. Slide the chute attachment downward, over the opening.
3. Pivot the direction lever to the middle position to lock the chute attachment in place. See Figure 3-3.



WARNING! Keep hands out of inlet and discharge openings while machine is running. There are rotating blades inside.

Set-Up

Adding Fuel

Refer to the Engine Operator's Manual packed with your jet sweep for information on adding fuel.



WARNING! Use extreme care when handling gasoline. Gasoline is extremely flammable and the vapors are explosive. Never fuel the machine indoors or while the engine is hot or running. Extinguish cigarettes, cigars, pipes and other sources of ignition.

Adding Oil

Refer to the Engine Operator's Manual packed with your jet sweep blower for information on adding and checking oil.



CAUTION: Always check the engine oil level before each use as instructed in the Engine Operator's Manual. Add oil as necessary. Failure to do so may result in serious damage to your engine.

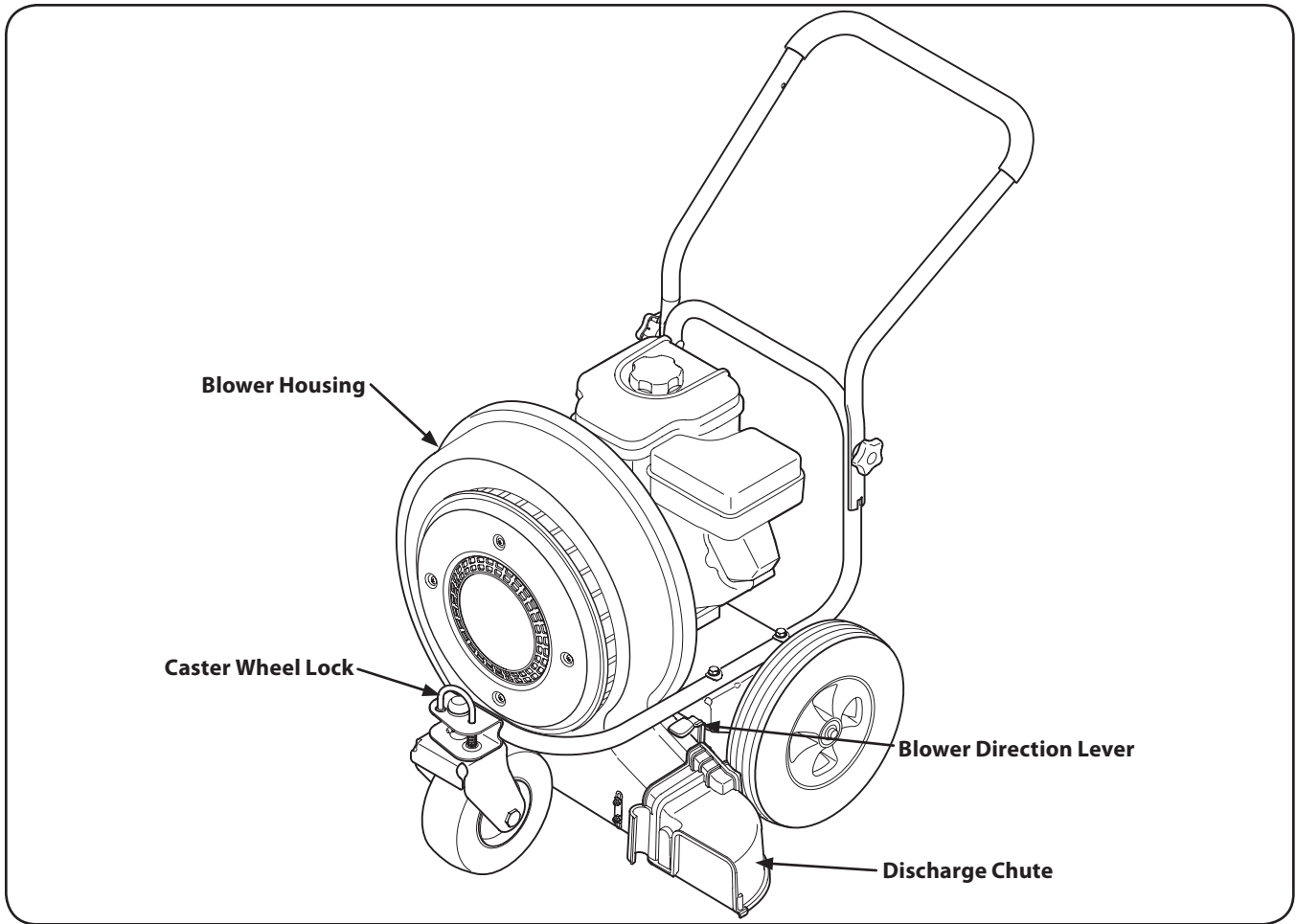

WARNING! Read and follow all safety rules and instructions in this manual, including the entire Operation section, before attempting to operate this machine. Failure to comply with all safety rules and instructions may result in personal injury.

Engine

Refer to the Engine Operator's Manual for details regarding all engine-related controls and features.

Caster Wheel Lock

The front caster wheel can be locked in position for straight ahead travel or allowed to swivel freely. See the Operation section for instructions.

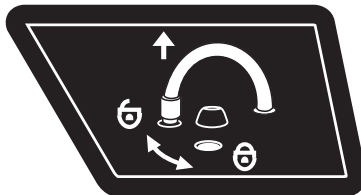

Discharge Chute

The discharge chute is located on the left side of the unit and directs air flow from the jet sweep.

Blower Direction Lever

The air flow can be directed to one of three directions using the blower direction lever to reposition the louvers.



WARNING! Do not stand in front of discharge area.



Starting & Stopping the Engine

Refer to the Engine Operator's Manual for instructions on starting and stopping the engine.

Adjusting the Blower Direction

The air flow can be directed to one of three directions using the blower direction lever to move the louvers.

NOTE: The blower direction lever must be in the middle position when operating the blower with the chute attachment to keep it locked in place.

1. Pull the lever out and away from the blower. See Figure 5-1.

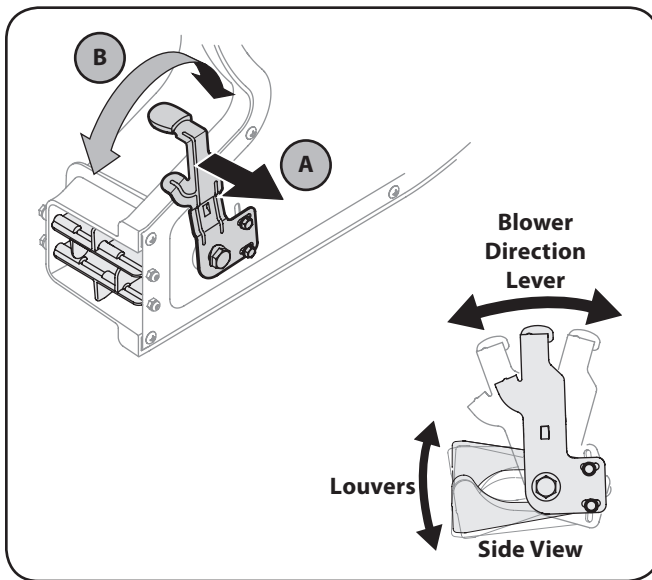

Figure 5-1

2. Move the lever to the left to direct airflow downward or to the right to direct airflow upward.
3. Release lever towards blower.



WARNING! Exercise caution when operating blower. Do not allow the directional discharge chute to point in the direction of bystanders or pets

Locking the Caster Wheel

The front caster wheel can be locked in position for straight ahead travel or allowed to swivel freely.

1. To lock the caster, lift the lock pin and rotate it rearward, releasing it into the larger hole. See Figure 5-2.

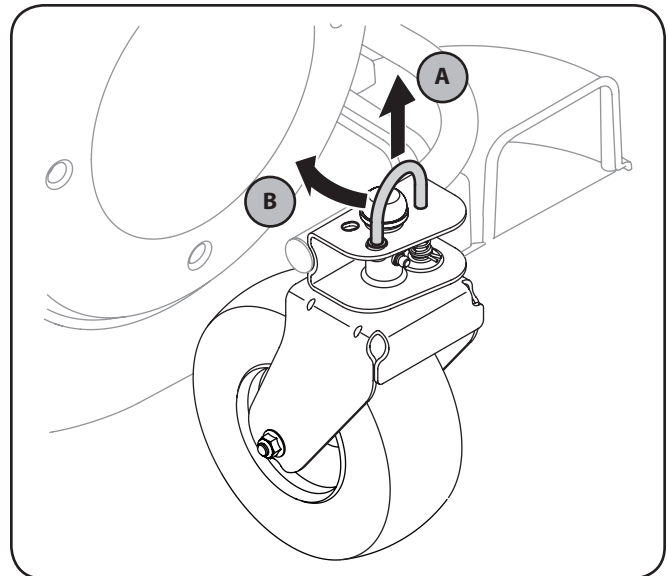

Figure 5-2

2. To unlock the caster, lift the lock pin and rotate it forward, releasing it into the smaller hole.

Maintenance



WARNING! Before performing any maintenance or repairs always stop engine.

Engine

Refer to the Engine Operator's Manual for all engine maintenance procedures and instructions.

Cleaning the Blower

Any fuel or oil spilled on the machine should be wiped off promptly. Do NOT allow debris to accumulate around the cooling fins of the engine, the fan intake area or on any other part of the machine.



WARNING! If the engine has been recently run, the engine, muffler and surrounding metal surfaces will be hot and can cause burns to the skin. Exercise caution to avoid burns.

Lubrication



WARNING! Before lubricating, repairing, or inspecting, always stop engine.

Wheels

Lubricate the rear and front axles with a spray lubricant once a season.

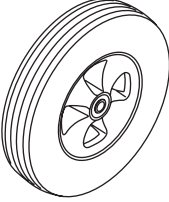
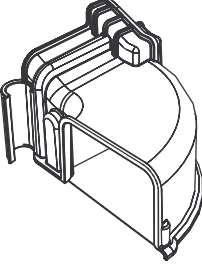
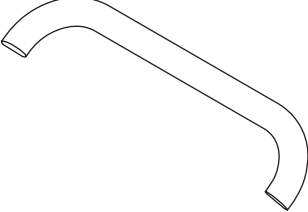
| Component | Part Number and Description |
|---|---|
|  | 734-04278 Front Wheel, 8.0 x 3.0 941-0706 Flange Bearing, .635 |
|  | 734-04279 Rear Wheel, 12 x 3 |
|  | 631-04253 Discharge Chute w/ Label 781-04175 Discharge Chute Base 710-04373A Discharge Chute Screws (3x) |
|  | 720-04091 Foam Grip |

Phone (800) 965-4CUB to order replacement parts or a complete Parts Manual (have your full model number and serial number ready). Parts Manual downloads are also available free of charge at www.cubcadet.com.

CUB CADET LLC

MANUFACTURER'S LIMITED WARRANTY FOR SNOW THROWERS, LOG SPLITTERS CHIPPER-SHREDDERS, CHIPPER-SHREDDER VACUUMS AND JET SWEEPS

The limited warranty set forth below is given by Cub Cadet LLC with respect to new merchandise purchased and used in the United States, its possessions and territories, and by MTD Products Limited with respect to new merchandise purchased and used in Canada and/or its territories and possessions.

This warranty is in addition to any applicable emissions warranty provided with your product.

For non-commercial use: Cub Cadet warrants this product (excluding Normal Wear Parts, as described below) against defects in material and workmanship for a period of three (3) years from the date of original retail purchase or lease.

For commercial uses and applications: Cub Cadet warrants this product (excluding *Normal Wear Parts*, as described below) against defects in material and workmanship for a period of one (1) year from the date of original retail purchase or lease.

"Cub Cadet" will, at its option, repair or replace, free of charge, any part found to be defective in materials or workmanship. This limited warranty shall only apply if this product has been operated and maintained in accordance with the Operator's Manual furnished with the product, and has not been subject to misuse, abuse, neglect, accident, improper maintenance, alteration, vandalism, theft, fire, water, or damage because of other peril or natural disaster. Damage resulting from the installation or use of any part, accessory or attachment not approved by Cub Cadet for use with the product(s) covered by this manual will void your warranty as to any resulting damage.

Normal Wear Parts are warranted to be free from defects in material and workmanship for a period of thirty (30) days from the date of purchase. Normal wear parts include, but are not limited to items such as: belts, skid shoes, shave plates, blades, debris collection bags, wheels and tires.

HOW TO OBTAIN SERVICE: Warranty service is available, WITH PROOF OF PURCHASE, through your local authorized service dealer. To locate the dealer in your area:

In the U.S.A.

To locate the dealer in your area, check your Yellow Pages, or contact Cub Cadet LLC at P.O. Box 361131, Cleveland, Ohio 44136-0019, or call 1-877-282-8684, or log on to our Web site at www.cubcadet.com.

In Canada

Contact MTD Products Limited, Kitchener, ON N2G 4J1, or call 1-800-668-1238 or log on to our Web site at www.mtdcanada.com.

This limited warranty does **not** provide coverage in the following cases:

- a. Routine maintenance items such as lubricants, filters, blade sharpening, tune-ups, brake adjustments, clutch adjustments, deck adjustments, and normal deterioration of the exterior finish due to use or exposure.
- b. Log splitter pumps, valves, and cylinders have a separate one year warranty.
- c. Cub Cadet does not extend any warranty for products sold or exported outside of the United States and/or Canada, and their respective possessions and territories, except those sold through Cub Cadet's authorized channels of export distribution.
- d. Replacement parts that are not genuine Cub Cadet parts.
- e. Service completed by someone other than an authorized service dealer.
- f. Transportation charges and service calls.

No implied warranty, including any implied warranty of merchantability of fitness for a particular purpose, applies after the applicable period of express written warranty above as to the parts as identified. No other express warranty, whether written or oral, except as mentioned above, given by any person or entity, including a dealer or retailer, with respect to any product, shall bind Cub Cadet. During the period of the warranty, the exclusive remedy is repair or replacement of the product as set forth above.

The provisions as set forth in this warranty provide the sole and exclusive remedy arising from the sale. Cub Cadet shall not be liable for incidental or consequential loss or damage including, without limitation, expenses incurred for substitute or replacement lawn care services or for rental expenses to temporarily replace a warranted product.

Some states do not allow the exclusion or limitation of incidental or consequential damages, or limitations on how long an implied warranty lasts, so the above exclusions or limitations may not apply to you.

In no event shall recovery of any kind be greater than the amount of the purchase price of the product sold. **Alteration of safety features of the product shall void this warranty.** You assume the risk and liability for loss, damage, or injury to you and your property and/or to others and their property arising out of the misuse or inability to use the product.

This limited warranty shall not extend to anyone other than the original purchaser or to the person for whom it was purchased as a gift.

HOW STATE LAW RELATES TO THIS WARRANTY: This limited warranty gives you specific legal rights, and you may also have other rights that vary in different jurisdictions.

IMPORTANT: Owner must present Original Proof of Purchase to obtain warranty coverage.

**Cub Cadet LLC, P.O. BOX 361131 CLEVELAND, OHIO 44136-0019; Phone: 1-877-282-8684
MTD Canada Limited - KITCHENER, ON N2G 4J1; Phone 1-800-668-1238**