

HL2 Series V.6/03 - 4" Tube Heater Installation, Operation, Maintenance and Parts Manual*

▲ WARNING: This heater must be installed and serviced by trained gas installation and service personnel only! Improper installation, adjustment, alteration, service or maintenance can cause property damage, injury or death. Read the installation, operating and maintenance instructions thoroughly before installing or servicing this equipment. Protect yourself and others by observing all safety information. Retain instructions for future reference.

*For complete installation instructions, see the General Manual that accompanied this piece. Additional literature on this and other products are available at www.reverberray.com.

HL2 Series

Project: _____ Date: _____
 Customer Name: _____
 Location: _____
 City: _____ State: _____ Zip: _____
 Contractor: _____
 Engineer: _____
 Address: _____
 City: _____ State: _____ Zip: _____
 Serial #: _____ Phone#: _____
 Local Representative: _____
 Date of Installation: _____
 Notes: _____

Table of Contents

	Page
Models	1
Warnings	2
Clearances to Combustibles	2
Product Summary	3
Product Instructions	3
Heater Requirements	4
Theory of Operation	4
Wiring Diagrams	5-7
Flowchart	8-9
Parts Listing	10-11

Models v.6/03

Qty.	Model #	Gas Type (circle one)	MBTU's	Straight Length	U-Tube Length	Weight	Typical Mount Height	Combustion Chamber	Radiant Emitter Tube	"Type" Tube Pkg #1	"Type" Tube Pkg. #2	Baffle Pieces
	HL2 20-65	N or LP	65 / 50	21'-7"	13'-0"	120 #	9'-14'	Aluminized	4" Aluminized	20-4 Alum	N/A	5
	HL2 20-75	N or LP	75 / 50	21'-7"	13'-0"	120 #	10' - 15'	Aluminized	4" Aluminized	20-4 Alum	N/A	5
	HL2 20-100	N or LP	96 / 65	21'-7"	13'-0"	120 #	11' - 18'	Aluminized	4" Aluminized	20-4 Alum	N/A	5
	HL2 30-65	N or LP	65 / 50	31'-3"	*17'-8"	160 #	10' - 15'	Aluminized	4" Aluminized	30-4 Alum	N/A	4
	HL2 30-75	N or LP	75 / 50	31'-3"	*17'-8"	160 #	11' - 18'	Aluminized	4" Aluminized	30-4 Alum	N/A	4
	HL2 30-100	N or LP	100 / 65	31'-3"	*17'-8"	160 #	12' - 20'	Aluminized	4" Aluminized	30-4 Alum	N/A	5
	HL2 30-125	N or LP	125 / 95	31'-3"	*17'-8"	160 #	13' - 23'	Aluminized	4" Aluminized	30-4 Alum	N/A	5
	HL2 40-65	N or LP	65 / 50	40'-11"	22'-8"	190 #	11' - 18'	Aluminized	4" Aluminized	40-4 Alum	N/A	2
	HL2 40-75	N or LP	75 / 50	40'-11"	22'-8"	190 #	11' - 18'	Aluminized	4" Aluminized	40-4 Alum	N/A	2
	HL2 40-100	N or LP	100 / 65	40'-11"	22'-8"	190 #	12' - 20'	Aluminized	4" Aluminized	40-4 Alum	N/A	4
	HL2 40-125	N or LP	125 / 95	40'-11"	22'-8"	190 #	13' - 23'	Aluminized	4" Aluminized	40-4 Alum	N/A	4
	HL2 40-150	N or LP	150 / 100	40'-11"	22'-8"	190 #	14' - 25'	Titanium Coated	4" Aluminized	40-4 Titan	N/A	4
	HL2 40-175	N or LP	175 / 125	40'-11"	22'-8"	190 #	15' - 27'	Titanium Coated	4" Aluminized	40-4 Titan	N/A	4
	HL2 50-125	N or LP	125 / 95	50'-7"	*27'-4"	235 #	15' - 27'	Aluminized	4" Aluminized	40-4 Alum	10-4 Alum	4
	HL2 50-150	N or LP	150 / 100	50'-7"	*27'-4"	235 #	15' - 27'	Titanium Coated	4" Aluminized	40-4 Titan	10-4 Alum	4
	HL2 50-175	N or LP	175 / 125	50'-7"	*27'-4"	235 #	16' - 30'	Titanium Coated	4" Aluminized	40-4 Titan	10-4 Alum	2
	HL2 50-200	N or LP	200 / 145	50'-7"	*27'-4"	235 #	17' - 35'	Titanium Coated	4" Aluminized	40-4 Titan	10-4 Alum	2
	HL2 60-150	N or LP	150 / 100	60'-3"	32'-4"	265 #	16' - 30'	Titanium Coated	4" Aluminized	40-4 Titan	20-4 Alum	2
	HL2 60-175	N or LP	175 / 125	60'-3"	32'-4"	265 #	16' - 30'	Titanium Coated	4" Aluminized	40-4 Titan	20-4 Alum	2
	HL2 60-200	N or LP	200 / 145	60'-3"	32'-4"	265 #	17' - 35'	Titanium Coated	4" Aluminized	40-4 Titan	20-4 Alum	2
	HL2 70-175	N or LP	175 / 125	69'-11"	*37'-2"	300 #	19' - 42'	Titanium Coated	4" Aluminized	40-4 Titan	30-4 Alum	2
	HL2 70-200	N or LP	200 / 145	69'-11"	*37'-2"	300 #	19' - 42'	Titanium Coated	4" Aluminized	40-4 Titan	30-4 Alum	2

* Model requires 5EA-SUB accessory package.

Warranty registration options:

1. Register online at www.reverberray.com/warranty
2. Complete this page and fax to Detroit Radiant Products Co.
3. Complete this page and mail to Detroit Radiant Products Co.



HL2 Series

HL2 Series Mechanical Instructions

⚠ WARNING!

NOT FOR RESIDENTIAL USE!

Do not use in the home, sleeping quarters, attached garages, etc.

⚠ WARNING!

This heater must be installed and serviced by trained gas installation and service personnel only. Read and understand these instructions thoroughly before attempting to install, operate or service this heater. Failure to comply could result in personal injury, asphyxiation, death, fire, and/or property damage. Retain these instructions for future reference.

⚠ WARNING!

This is not an explosion-proof heater. Where there is the possibility of exposure to flammable vapors, consult the local fire marshal, the fire insurance carrier and other authorities for approval of the proposed installation.

⚠ WARNING!

Failure to comply with the stated clearances to combustibles could result in personal injury, death and/or property damage.

⚠ WARNING!

In locations used for the storage of combustible materials, signs must be posted to specify the maximum permissible stacking height to maintain the required clearances from the heater to the combustibles. Signs must either be posted adjacent to the heater thermostats or in the absence of such thermostats, in a conspicuous location.

⚠ WARNING!

This heater should be installed so that the minimum clearances to vehicles, as marked on the heater, will be maintained. If vehicle lifts are present, ensure that these clearances will be maintained from the highest raised vehicle.

CLEARANCES TO COMBUSTIBLES (IN.)

MODEL NO.	MOUNTING ANGLE	SIDE		TOP	BELOW
		FRONT	BEHIND		
HL2 (20,30,40) - 65, 75 [N,P]	0°	9	9	6	60
	45°	39	8	10	60
	0°	29	8	6	60
	0°	7	7	6	30
HL2 (20,30,40) - 100 [N,P]	0°	14	14	6	66
	45°	39	8	10	66
	0°	29	8	6	66
	0°	16	16	6	66
HL2 (30,40,50) - 125 [N,P]	0°	20	20	6	76
	45°	58	8	10	76
	0°	42	8	6	76
	0°	20	20	6	76
HL2 (40,50,60) - 150 [N,P]	0°	24	24	6	81
	45°	58	8	10	81
	0°	42	8	6	81
	0°	23	23	6	81
HL2 (40,50,60,70) - 175 [N,P]	0°	11	11	6	44
	45°	34	34	6	92
	0°	63	8	10	92
	0°	50	8	6	92
HL2 (50,60,70) - 200 [N,P]	0°	30	30	6	92
	0°	11	11	6	44
	0°	41	41	6	94
	45°	63	8	10	94
HL2 (50,60,70) - 200 [N,P]	0°	54	8	6	94
	0°	30	30	6	94
	0°	11	11	6	44

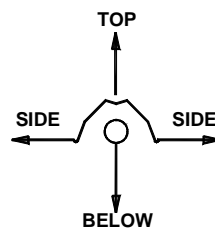

0° MOUNTING ANGLE

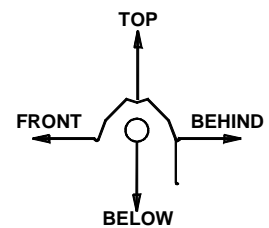

0° W/1 SIDE SHIELD

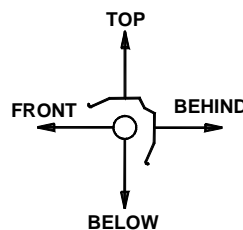

45° MOUNTING ANGLE

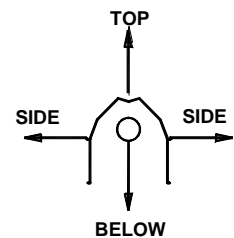

0° W/2 SIDE SHIELDS

HL2 Series Mechanical Instructions

This supplement is designed to address the specifics of the HL2 Series - see page 12 for product features.

Product Summary

HL2 Series heaters are available from 20 to 70 foot, 65,000 to 200,000 BTU's, natural or LP gas. HL2 Series are positive pressure, two-stage heaters that feature aluminized steel for it's radiant pipes.

Operational Features

HL2 Series heaters require a 24 Volt, two-stage thermostat to operate. Each heater has a round terminal strip (or yellow cord) that accepts three 1/4 in. insulated spade terminals for the thermostat wiring. **Do not install 120V to this 24V connection.**

There are two versions of the HL2 Series. The standard version comes without a relay board (HLRB) and the other is supplied with a relay board (HLRB) installed. A HL2 Series unit **without** a relay board (HLRB) supplies it's own control voltage and is identified by the white band located around the terminal plug. If units are common vented or if two or more models are to be controlled by a single thermostat, they must be factory assembled with relay boards (HLRB) and installed using an external transformer (field supplied) as shown on page 6. A HL2 Series unit **with** a relay board (HLRB) installed is identified by the orange band around the terminal strip.

On stainless steel heaters, units with a relay board (HLRB) will be labeled accordingly. All models assembled with a HLRB reference the suffix "D" on the AGA rating plate.

Specific Mechanical Instructions

Be sure to indentify the titanium coated combustion chamber (150-200 MBTU/H) and place as the first tube section directly following the burner box. The identification sticker found on the swagged end of the tubing will identify the titanium coated combustion tube.

175,000 and 200,000 BTU/H Models must be installed with a stainless steel tube clamp at the second joint of the exchanger between the first and second radiant tubes.

Note baffle quantities for your model and place baffles in the last tubes (farthest from the burner) as shown on pages 13-14 of the general manual, and below (*).

Tube Installation Sequence

	Aluminized (50-100 MBTU/H)	Aluminized	B = Burner Location			* Baffle Location
B	<input type="text"/>	<input type="text" value="*"/>				
B	Aluminized (50-125 MBTU/H)	Aluminized	Aluminized			
B	<input type="text"/>	<input type="text"/>	<input type="text" value="*"/>			
B	Aluminized or Titanium (50-125 MBTU/H) (150-175 MBTU/H)	Aluminized	Aluminized	Aluminized		
B	<input type="text"/>	<input type="text"/>	<input type="text"/>	<input type="text" value="*"/>		
B	Aluminized or Titanium (50-125 MBTU/H) (150-200 MBTU/H)	Aluminized	Aluminized	Aluminized	Aluminized	
B	<input type="text"/>	<input type="text"/>	<input type="text"/>	<input type="text"/>	<input type="text" value="*"/>	
B	Aluminized or Titanium (50-125 MBTU/H) (150-200 MBTU/H)	Aluminized	Aluminized	Aluminized	Aluminized	Aluminized
B	<input type="text"/>	<input type="text"/>	<input type="text"/>	<input type="text"/>	<input type="text"/>	<input type="text" value="*"/>



HL2 Series

Electrical Requirements

- ◆ 120 Volt - 60 Hz GRD, 3-wire.
- ◆ 24V thermostat connection.
- ◆ Starting current 4.8 amps
- ◆ Running current 1.1 amps

Gas Requirements

- ◆ Manifold Pressure
 - Nat. 3.5" • LP. 10.0"
- ◆ Minimum Inlet Pressure
 - Nat. 5.0" • LP. 11.0"
- ◆ Maximum Inlet
 - Nat. 14.0" • LP. 14.0"

Ventilation Requirements

- ◆ Consult the general manual for venting instructions.
- ◆ For unvented operation, there must be a positive air displacement of at least 4.0 CFM per 1000 BTU/H for natural gas or 4.5 CFM per 1000 BTU/H for LP gas. WVE-4 termination cap must also be used.

Theory of Operation

Standby:

The Micro 60U24 control continually checks for internal faults, safety circuit integrity, and relay contact positioning.

Starting Circuit:

Upon a call for heat, the control will verify that the differential safety pressure switch is in the proper position. The fan relay energizes the fan, an operational static pressure is achieved and the normally open differential pressure switch will close, initiating the ignition sequence. The glow-bar is powered and after 45 seconds the main gas valve opens. If flame is not established the heater will attempt to re-ignite for a total of three trials for ignition and then proceed to lockout.

First Stage Running Circuit:

After ignition the flame-rod monitors the main burner flame. If flame is lost, the control acts to close the gas valve within one second and a new trial sequence, identical to the start up sequence, is initiated. If proof is not established within 8.5 seconds, the unit will retry 2 additional ignition sequences and then proceed to hard lock-out. The control can be reset by interrupting the power source or at the thermostat.

Second Stage Running Circuit:

Stage two on the gas valve is powered directly from the second stage of the thermostat. In order for the second stage to flow the higher output, the first stage has to be energized as well. The thermostat will determine which stage is required to maintain the desired comfort level.

Shut Down:

When the thermostat is satisfied the fan will enter into a 2 minute post-purge cycle.

Soft Lockout:

In the event of an external interruption (wind, gas, etc.) the heater will go into a "soft-lockout" feature. In this mode the heater will attempt a normal start-up after approximately 15 minutes. In the event of continued problems, the heater will go into a hard lock-out mode.

Lockout Codes:

In event of a component failure, a red LED diagnostic light located on the burner box end panel will flash a code identifying the fault. Lockout codes are summarized in the table below. Some fault codes have a time delay before the LED will flash. Refer to the FAULT CODE DELAY on the chart to see the approximate time delay.

LED CODE	FAULT STATUS	FAULT CODE DELAY
Initial flash on power up, then steady off	Normal operation	Immediate
Steady on	Module failure / Internal fault	Immediate
1 flash	Ignition failure	30-32 minutes
2 or 3 flashes	APS - Note: fan / intake / exhaust	10-12 minutes
4 flashes	Solenoid valve fault / Leaky valve / Flame amplifier fault	Immediate
No flash on 117V start up	Transformer fault	Immediate

Note: Hard lockout **LED CODE** will appear upon completion of the soft lockout sequence of operation.

Internal Wiring Diagrams

MICRO 60U-24

MICRO 60U-24 LADDER DIAGRAM

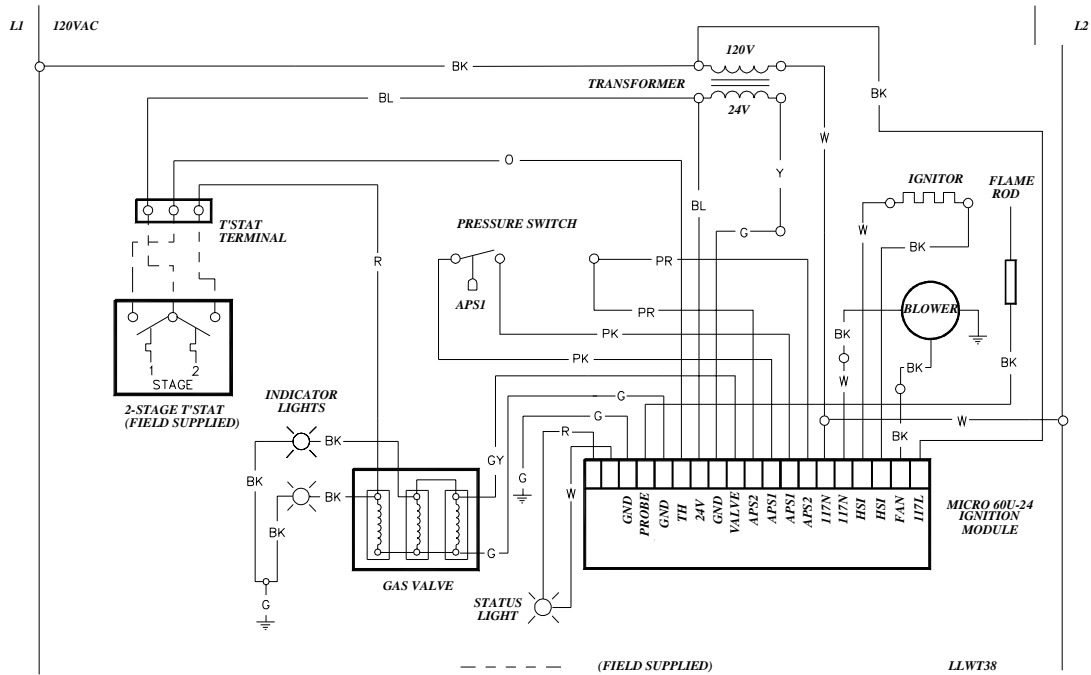

MICRO 60U-24 BLOCK DIAGRAM

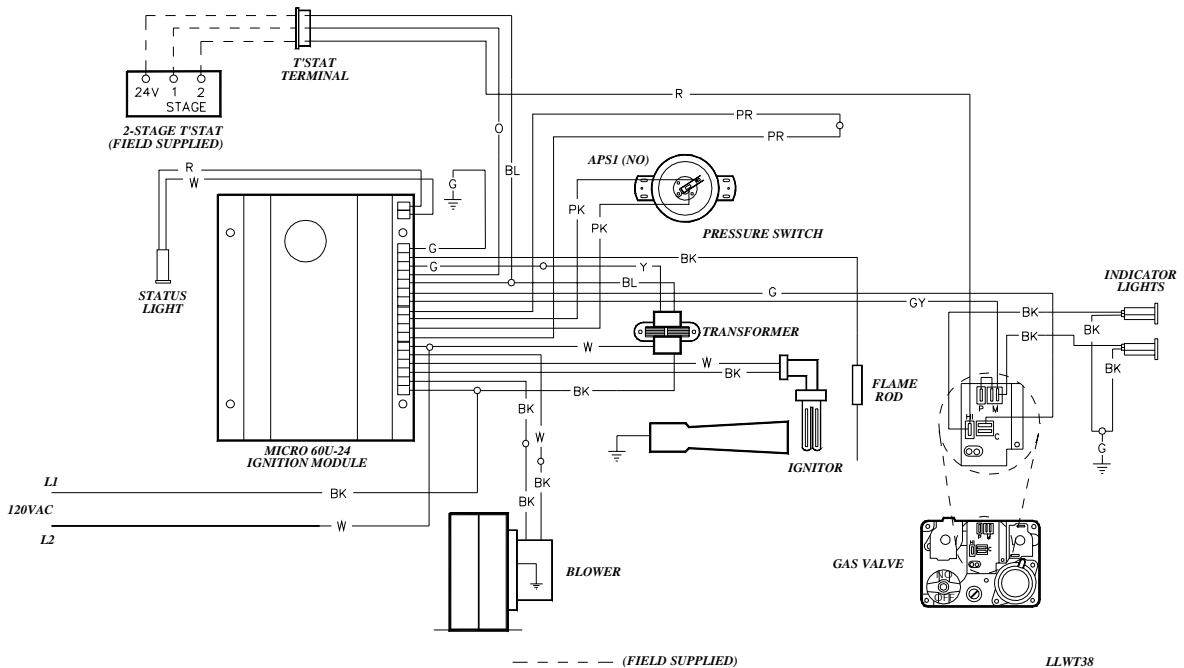

HL2 Series

Field Wiring Diagrams

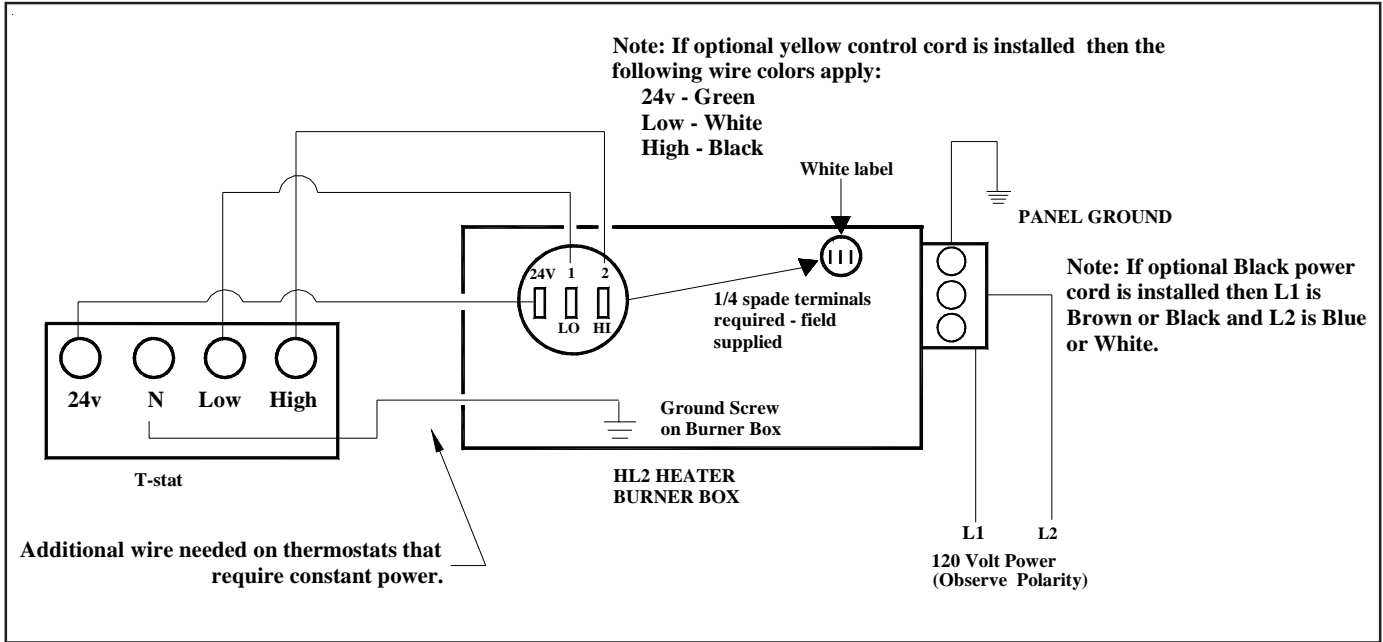

Single heater, single thermostat, **no relay board** (white label).

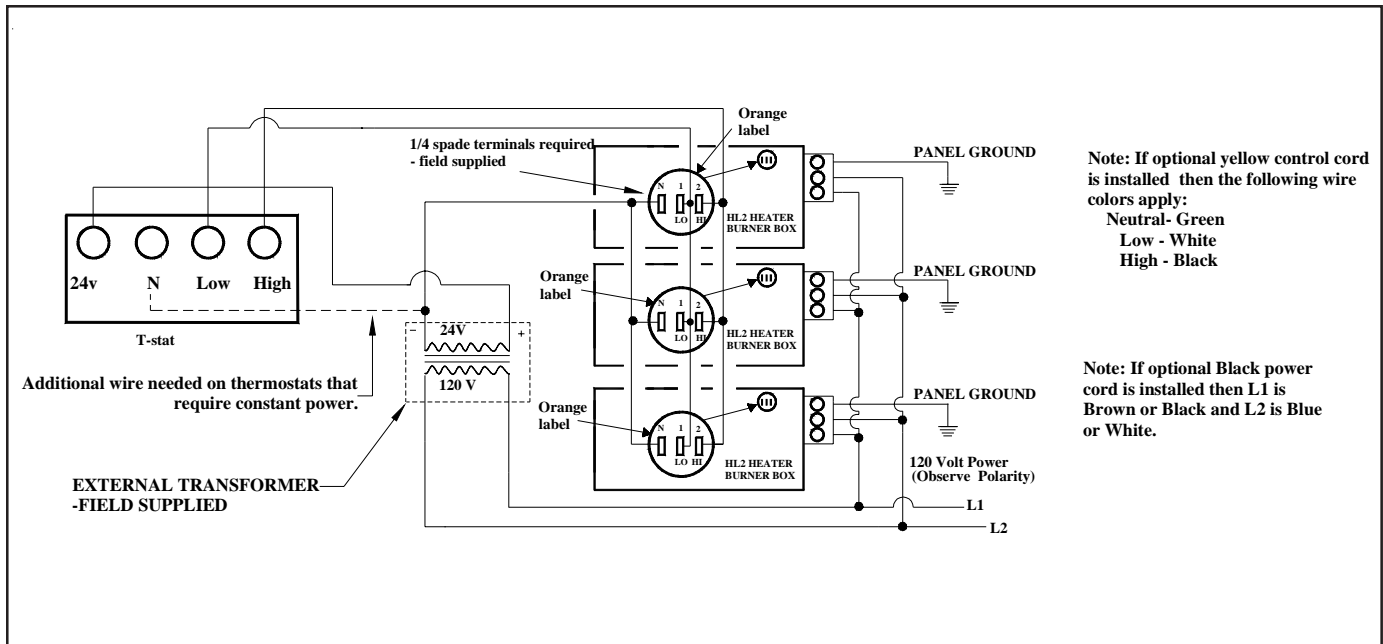

Multiple heaters, single thermostat, **with a relay board** (HLRB - orange label).

Alternative Wiring Diagrams

MICRO 60U-24 WITH HLRB RELAY BOARD

MICRO 60U-24 LADDER DIAGRAM - WITH RELAY BOARD

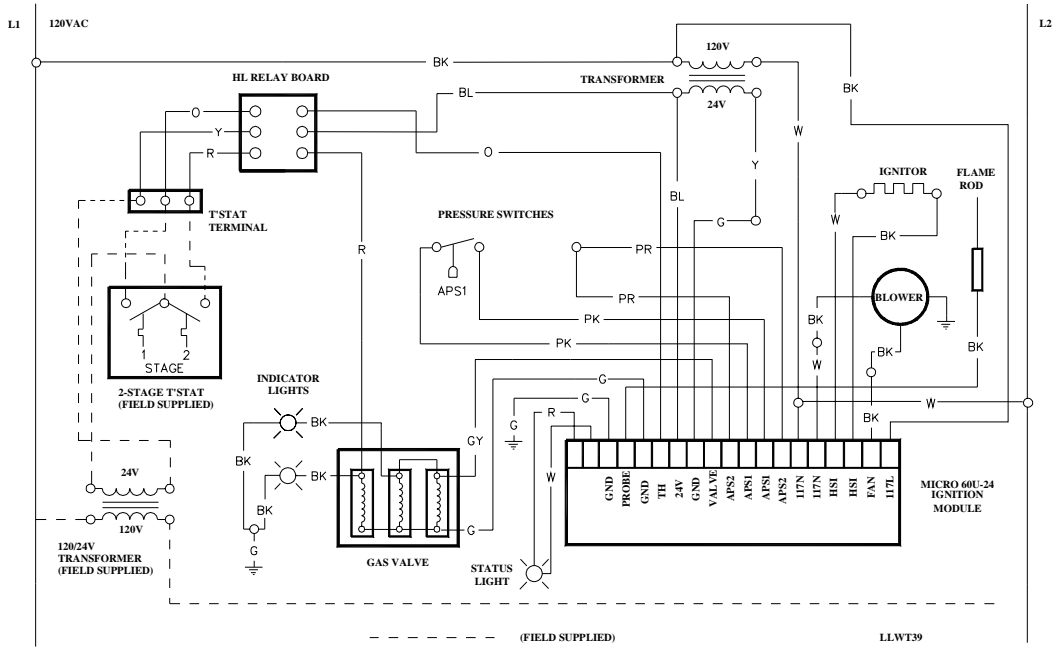

MICRO 60U-24 BLOCK DIAGRAM - WITH RELAY BOARD

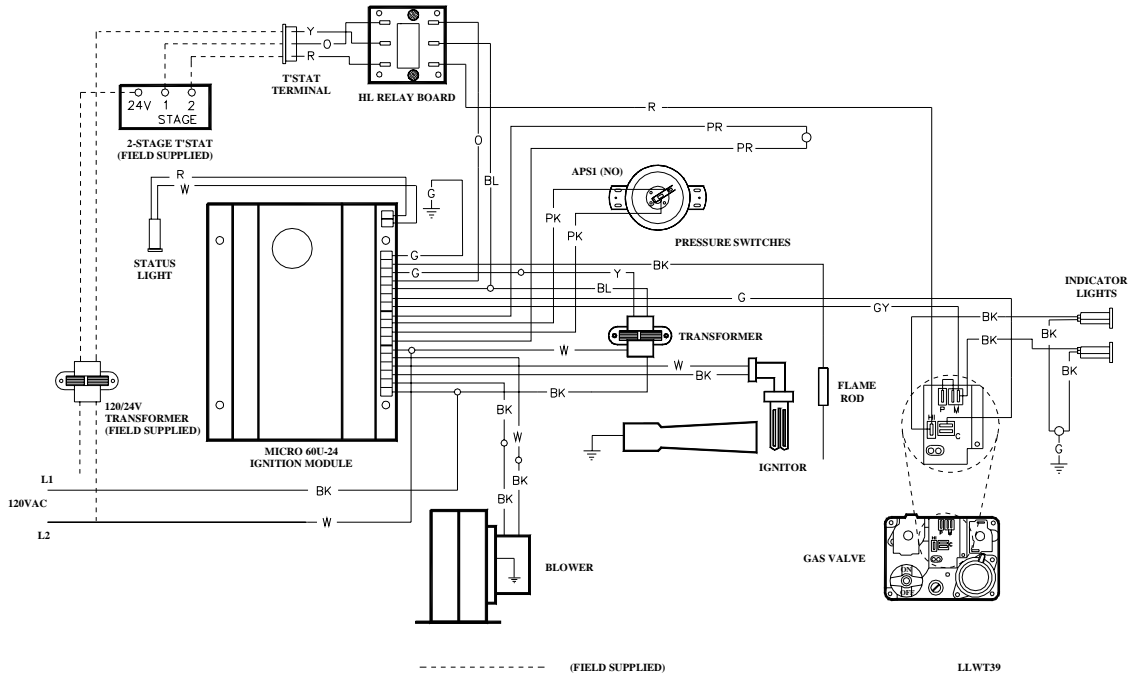

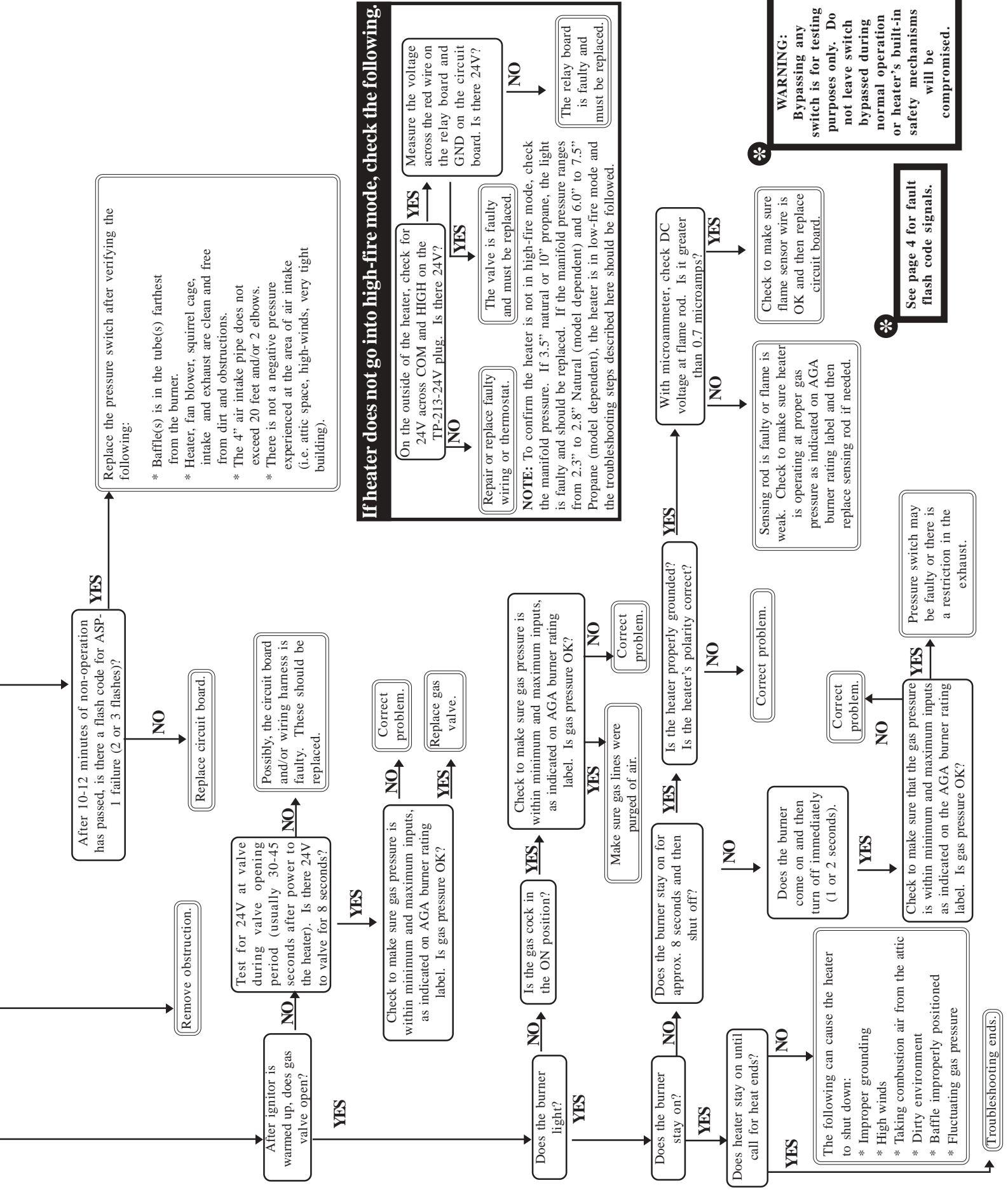

If heater does not go into high-fire mode, check the following.

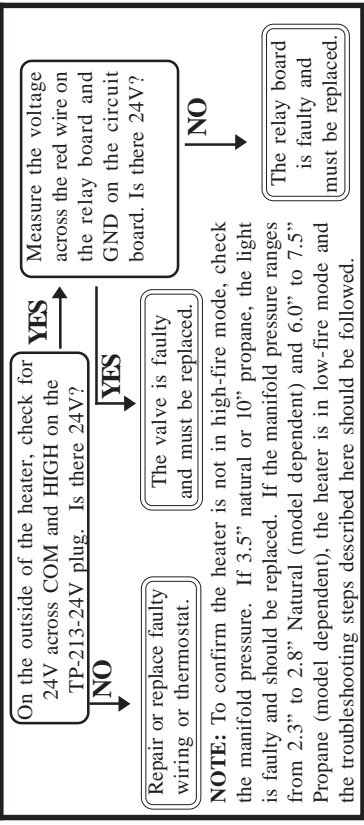

WARNING:
Bypassing any switch is for testing purposes only. Do not leave switch bypassed during normal operation or heater's built-in safety mechanisms will be compromised.

See page 4 for fault flash code signals.

Basic Parts List

HL2 SERIES PARTS LISTING

TP#	ITEM	TP#	ITEM
TP-1	CONTROL BOX COVER	TP-111	5' ALUM. TUBE, PAINTED W/1 CLAMP
TP-5	FLANGE GASKET	TP-112	5' REFLECTOR
TP-9	CONDUIT COUPLING	TP-122	GASKET FOR AIR ORIFICE & AIR COLLAR
TP-10	CONDUIT 4" X 1/2"	TP-200	BURNER (50 TO 100 MBTU/H)
TP-11	GLO-BAR IGNITOR BOX	TP-201	BURNER (125 MBTU/H TO 200 MBTU/H)
TP-12	GLO-BAR IGNITOR BOX COVER	TP-202	16" BURNER TUBE W/ FLANGE
TP-14	SIGHT GLASS GASKET	TP-204	GAS ORIFICE - CONSULT FACTORY
TP-15	SIGHT GLASS	TP-205	GLO-BAR HOLDER
TP-16	SIGHT GLASS WASHER	TP-208	"Z" MOUNTING BRACKET
TP-19B	WIRE HANGER	TP-212	1/2" X 3" PIPE NIPPLE
TP-20C	120" REFLECTOR	TP-217	PRESSURE BARB FITTING
TP-21B	TUBE CLAMP	TP-218	EXHAUST PRESSURE TUBE (VINYL)
TP-26A	10 FT. ALUMINIZED RADIANT/COMBUSTION TUBE	TP-220	STAIN. STL. TUBE CLAMP (175 & 200 MBTU/H)
TP-26B	10 FT. TITANIUM COATED COMBUSTION TUBE	TP-221	GLO-BAR HOLDER GASKET
TP-26D	10 FT. 304 STAINLESS RADIANT TUBE	TP-222	FLAME ROD
TP-26E	10 FT. 409 STAINLESS COMBUSTION TUBE	TP-223	GAS MANIFOLD
TP-31B	MOUNTING BRACKET	TP-303A	END PANEL - RIGHT
TP-33B	1/2" GAS COCK	TP-802	END PANEL - LEFT
TP-44	AIR ORIFICE W/SCREEN (CONSULT FACTORY)	TP-804	CONTROL BOX
TP-50	GLO-BAR IGNITOR	TP-825	OPTIONAL HLRB RELAY BOARD
TP-54	BURNER BOX CENTER PANEL	TP-826	40VA TRANSFORMER (OLD TP219)
TP-55A	FAN BLOWER	TP-827	RED LED DISPLAY DIAGNOSTIC LIGHT
TP-65I	33" INTERLOCKING HEAT DIFFUSER (BAFFLE)	TP-828	YELLOW OPERATIONAL IND. LIGHT (OLD TP216)
TP-66	2" X 4" OUTLET BOX	TP-832	THERMOSTAT TERMINAL STRIP (OLD TP213)
TP-67	2" X 4" OUTLET BOX COVER	TP-840	36E96-224 TWO STAGE GAS VALVE-NAT (OLD TP210)
TP-68A	STRAIN RELIEF BUSHING	TP-841	36E96-226 TWO STAGE GAS VALVE-LP (OLD TP210P)
TP-70	CONTROL BOX COVER GASKET (PER FOOT**)	TP-851	MICRO-60-24 DIAGNOSTIC CIRCUIT BOARD
TP-76	RUBBER GROMMET	TP-852	WIRE HARNESS SET (3 PCS.) FOR MICRO 60 BOARD
TP-82	REFLECTOR CENTER SUPPORT	TP-NOPS	N. O. Pressure Switch (Select Switch Below, BTU Dependent)
TP-83	STAINLESS STEEL FLEX CONNECTOR	(TP-264B)	DIFFERENTIAL PRESSURE SWITCH - 50 TO 100 MBTU/H
TP-97	1/4" x 1/4" BRASS INT./EXT. ATMOS. BARB FITTING	(TP-264E)	DIFFERENTIAL PRESSURE SWITCH - 125 & 150 MBTU/H
TP-105	REFLECTOR END CAP	(TP-264D)	DIFFERENTIAL PRESSURE SWITCH - 175 MBTU/H
TP-106	REFLECTOR CLIP	(TP-264F)	DIFFERENTIAL PRESSURE SWITCH - 200 MBTU/H
TP-108	5' AL-TI TUBE, PAINTED W. ONE CLAMP		







** 6' TOTAL NEEDED TO COVER OUTER EDGES OF A BURNER BOX.



Kit Contents & Product Features

Kit contents for the HL2 Series are shown below. Reference the proper column for your particular models length.

FILLED BY:		HL2 SERIES KIT CONTENTS					
TP#	DESCRIPTION	20 FOOT	30 FOOT	40 FOOT	50 FOOT	60 FOOT	70 FOOT
TP-19B	4" Hangers	3	4	5	6	7	8
TP-21B	4" Tube Clamps	2	3	4	5*	6*	7*
TP-33B	1/2" Gas Cock	1	1	1	1	1	1
TP-82	4" Refl. Cntr. Sprt.	2	3	4	5	6	7
TP-83	24" SS Flex Line	1	1	1	1	1	1
TP-105	Refl. Endcaps	2	2	2	2	2	2
TP-106	Refl. Endcap Clips	8	8	8	8	8	8
IOM	Install / Op Manual	1	1	1	1	1	1

						
4" Hanger TP-19B	4" Butt Clamp TP-21B	Gas Cock 1/2" TP-33B	Bag of Reflector End Cap Clips. TP-106	24" SS Flex Connect TP-83	Reflector End Caps TP-105	General IOM (LIOGT) AND HL2 Series Insert (LIOHL2)

<p>Notes</p> <p>*One 4" stainless steel butt clamp is provided for each 175,000-200,000 BTU model. Place as shown in IOM.</p>	 <p>4" Reflector Center Support - TP-82</p>
--	--

Product Features

APPROVALS

- IAS, CSA, CGA, CE.
- Indoor approval.
- Outdoor approval with OD-Kit.
- Commercial approval.

BURNER SIGHT GLASS

- For burner inspection.

COMBUSTION AIR INLET & VENT

- 4" Male duct.

ENAMELED CONTROL BOX

- Outside air collar (4") attached.
- Totally enclosed components.

CONTROLS

- 100% safety shut off.
- Differential pressure switch.
- Silicon carbide hot surface igniter.
- Flame rod sensing.
- Pre and post purge controls.
- Microprocessor circuit board provides soft lockout and self-diagnostic features.

EMITTER & COMBUSTION TUBES

- 16ga. 4" O.D. aluminized steel.
- All tubes coated with high temperature, corrosion resistant black coating .95 emissivity. Slip fit connection.
- Titanium treated combustion chamber (150-200 MBTU/H models).

GAS CONNECTION

- 1/2" gas cock included.
- 7/8" flare-2' S.S. flex included.

RADIANT SURFACE AREA (SQ. FT.)

- 20' Models – 20.2
- 30' Models – 30.4
- 40' Models – 40.5
- 50' Models – 50.6
- 60' Models – 60.7
- 70' Models – 70.9

WARRANTY

- 1 year - Burner box components.
- 5 years - Combustion and radiant tubes.
- 10 years - Stainless steel burner.

OTHER

- One reflector center support per reflector.
- Turbulator baffle included.
- Stainless steel upgrades available.
- Made in U.S.A.