

UPS OPERATING INSTRUCTIONS

AEG



PROTECT 1.M

PROTECT 1.040

Thank you for deciding to purchase the PROTECT 1.M UPS from AEG Power Solutions. The following safety instructions are an important part of the operating instructions and will protect you against problems from operating errors and possible dangers. Please read these instructions carefully prior to commissioning!

1 **Notes on these Operating Instructions**

Duty to provide information

These operating instructions help you to install and operate the **U**ninterruptible **P**ower **S**upply (UPS) PROTECT 1.M as well as its USV modules PROTECT 1.040 and associated external battery units PROTECT 1.M BP (referred to below jointly as PROTECT 1.M) in accordance with its designated use, safely and correctly. These operating instructions contain important information for avoiding dangers.

Please read these instructions carefully prior to commissioning!

These operating instructions are an integral part of PROTECT 1.M.

The operator of this unit is obliged to communicate these operating instructions to all personnel transporting or starting up PROTECT 1.M or performing maintenance or any other work on the unit.

Validity

These operating instructions comply with the current technical specifications of PROTECT 1.M at the time of publication. The contents do not constitute a subject matter of the contract, but serve for information purposes only.

Warranty and liability

We reserve the right to alter any specifications given in these operating instructions, especially with regard to technical data and operation.

Claims in connection with supplied goods must be submitted within one week of receipt, along with the packing slip. Subsequent claims cannot be considered.

The warranty does not apply for damage caused by non-compliance with these instructions (such damage also includes damage to the warranty seal). AEG will accept no liability for consequential damage. AEG will rescind all obligations such as

warranty agreements, service contracts, etc. entered into by AEG or its representatives without prior notice in the event of maintenance and repair work being carried out with anything other than original AEG parts or spare parts purchased from AEG.

Handling

PROTECT 1.M is designed and constructed so that all necessary steps for start-up and operation can be performed without any internal manipulation of the unit. Maintenance and repair work may only be performed by trained and qualified personnel.

Illustrations are provided to clarify and facilitate certain steps.

If danger to personnel and the unit cannot be ruled out in the case of certain work, it is highlighted accordingly by pictographs explained in the safety regulations of chapter 3.

Hotline

If you still have questions after having read these operating instructions, please contact your dealer or our "Hotline":

Tel: +49 (0)180 5 234 787

Fax: +49 (0)180 5 234 789

Internet: www.AEGpartnerNet.com

Copyright

No part of these operating instructions may be transmitted or reproduced by any electronic or mechanical means without the express prior written permission of AEG.

© Copyright AEG 2009. All rights reserved.

Table of Contents

1	Notes on these Operating Instructions.....	3
2	Introduction.....	7
2.1	Product description.....	7
2.2	Technical Data.....	10
3	Safety Regulations	14
3.1	Important Instructions and Explanations	14
3.2	Accident Prevention Regulations	14
3.3	Qualified Personnel	15
3.4	Safety Instructions for PROTECT 1.M	15
3.5	CE certificate	18
4	Set-up.....	18
4.1	Unpacking and Inspection	19
4.2	Transport to Installation Site.....	21
4.3	Set-Up	22
5	External View	23
5.1	Front and Rear View of PROTECT 1.M (chassis)....	23
5.2	Front/Rear and 3D View PROTECT 1.040 (module)...	24
5.3	Front and Rear View (communication module).....	24
5.3	Front and Rear View (communication module).....	25
5.4	Front View of LCD Panel.....	25
5.5	Display Panel.....	26
6	Installation	27
6.1	Installation Notes	27
6.2	Set-up and Installation of the Modules.....	31

7	Adding/Removing Modules	33
7.1	Active Redundancy	33
7.2	Installing and Removing UPS Modules.....	33
7.2.1	Basic procedure for installing a PROTECT 1.040 UPS module...	34
7.2.2	Basic procedure for removing a PROTECT 1.040 UPS module ..	34
8	Operating and Maintenance.....	35
8.1	Operation.....	35
8.1.1	Start-up	37
8.1.2	Shutting down	37
8.1.3	Inquiries	38
8.1.4	Setup.....	39
8.2	Maintenance.....	41
8.3	Shutdown and UPS Management Software.....	42
9	Communication Interfaces	43
10	Troubleshooting and Fault Rectification.....	44
11	Reference Table for the Display and UPS Operating	45
11.1	Normal operation.....	45
11.2	Battery Operation	45
11.3	Bypass Operation.....	45
11.4	Warning Signal if Battery System Not Connected....	46
11.5	Warning Signal for Phase Loss or Phase Sequence Error.....	46
11.6	Overload Protection.....	47
12	Minimum Number of Battery Packs	48
13	List of terms.....	51
13.1	Technical terminology	51

2 Introduction

2.1 Product description

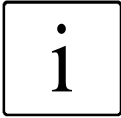

PROTECT 1.M ("M" for modular structure) is an **Un**interruptible **P**ower **S**upply (UPS) for important loads such as small data centres, servers, network components, telecommunication facilities and the like.

The PROTECT 1.M connection to the mains can be either three or one-phase. The load connection, i.e. the UPS output, is always one-phase. The online-/double-converter technology guarantees the highest levels of reliability and performance. This standard product is designed as a highly intelligent module construction with a rack-type design. One module of the AEG USV PROTECT 1.040 corresponds to an UPS with full functions. Depending on the requirements for output power and serviceability, the user can increase or reduce the number of modules in the AEG UPS PROTECT 1.M to achieve an optimum price/ performance ratio.

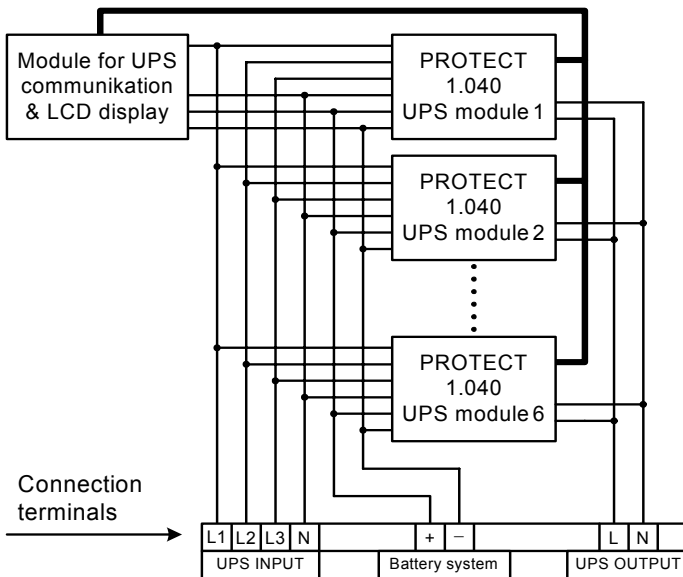

Fig.: Diagram in principle of the PROTECT 1.M

The PROTECT 1.M has been designed for operating up to six UPS modules. Depending on the output power required, the unit is operated in normal mode with between one and six modules installed. These modules can easily be installed, removed or replaced under a very wide range of operating conditions.

PROTECT 1.M uses a high-performance communication module to collect information from the individual UPS modules via the internal network within the unit and displays this information on an LC display. This greatly facilitates operation of the UPS.

PROTECT 1.M protects your systems against numerous power supply problems such as mains failures, voltage and frequency fluctuations, under and overvoltage, voltage distortions, voltage harmonics, etc.

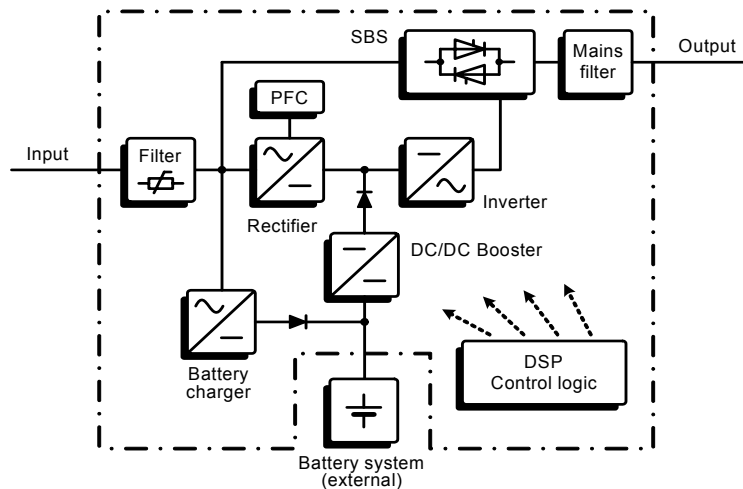

Fig.: Component diagram of an individual PROTECT 1.040 UPS module

The UPS is connected between the public utility mains and the loads to be protected.

The power sections of the UPS module rectifier convert the mains voltage to DC voltage for supplying the inverters. The circuit technology used (PFC) enables sinusoidal current consumption and therefore operation with little system

disturbance. Separate battery chargers configured with switch mode power supply technology are responsible for charging or trickle-charging the battery connected in the intermediate circuit. The configuration of these charging rectifiers means the harmonic content of the charging current for the battery is almost zero, which increases the service life of the battery even more. The inverters are responsible for converting the DC voltage into a sinusoidal output voltage. A microprocessor-driven control based on a pulse-width modulation (PWM) integrated in each UPS module guarantees, in conjunction with digital signal processor technology and extremely fast pulsating IGBT power semiconductors of the inverters, a voltage system of the highest quality and availability on the secured busbar.

In the event of mains faults (e.g. current failures), the voltage continues to be supplied from the inverters to the load without any interruption. From this point onwards, the inverters draw their power from the battery instead of the rectifiers. Since no switching operations are necessary, there is no interruption in the supply to the load.

The greatest possible supply reliability of connected loads is attained by the parallel connection of up to max. six PROTECT 1.040 UPS modules. The n+x technology thus guarantees maximum reliability through up multiple active redundancy on the one hand as well as on the other hand the possibility of increased power with simple redundancy or even only higher UPS power without any redundancy.

The automatic electronic bypass serves to increase the reliability of the supply further. It switches the public mains directly through to the load without any interruption, e.g. when there is a system overload. As a result, the automatic bypass represents an extra passive redundancy for the load.

An integrated, manually operated bypass unit ensures an uninterrupted supply to the connected loads in the case of maintenance and/or service work. The internal electronic part (with the exception of the metal-clad manual bypass) can be disconnected via the mains input miniature circuit breakers.

Number of UPS modules Load	1 module	2 modules	3 modules	4 modules	5 modules	6 modules	
4 kVA	no redundancy	n+1 (4 kVA)	n+2 (8 kVA)	n+3 (12 kVA)	n+4 (16 kVA)	n+5 (20 kVA)	
8 kVA	---	no redundancy	n+1 (4 kVA)	n+2 (8 kVA)	n+3 (12 kVA)	n+4 (16 kVA)	
12 kVA		---	no redundancy	n+1 (4 kVA)	n+2 (8 kVA)	n+3 (12 kVA)	
16 kVA			---	---	no redundancy	n+1 (4 kVA)	n+2 (8 kVA)
20 kVA		---			---	no redundancy	n+1 (4 kVA)
24 kVA						---	no redundancy

Fig.: Table showing the level of redundancy depending on the installed modules and available output power

2.2 Technical Data

Type rating

PROTECT 1.M (system)	max. 24 kVA (cos φ = 0.7 lag.) 16800 W
PROTECT 1.040 (module)	4000 VA (cos φ = 0.7 lag.) 2800 W

UPS input

3ph~ or 1ph~ / N / PE

Rated connection voltage	400 V / 230 Vac (3ph~) or 230 V (1ph~)
Voltage range without battery operation	277 Vac – 520 Vac ±3% (Rectifier 3ph~) 160 Vac – 300 Vac ±3% (Rectifier 1ph~)

	176 VAC – 264 VAC \pm 3% (Bypass)
Frequency	50 Hz / 60 Hz (Automatic detection)
Frequency tolerance range	\pm 4 Hz
Current consumption at full load (max.)	
PROTECT 1.M (system)	44 A (3ph~) or 132 A (1ph~) / 155 A (Bypass)
PROTECT 1.040 (module)	7.3 A (3ph~) or 22 A (1ph~)
System disturbance factor	$\lambda \geq 0.98$

UPS output

Nominal voltage output	220 / 230 / 240 Vac \pm 2% (configuration via "CompuWatch" software)
Nominal frequency	50 Hz / 60 Hz \pm 0.2 Hz (dependent on mains frequency)
Type of voltage	Sine, distortion < 3% THD (linear load) < 6% THD (non-linear load)
Crest factor	3:1
Overload behaviour with mains supply	Up to 105% continuous; > 105% – < 130% for 30s 130% for 2s Following this, automatic, uninterrupted switchover to integrated bypass (SBS). Switch-off after 1 min. if overload continues to be present (switch back if overload decreases = load < 90%)
Overload behaviour with battery operation	Up to 105% continuous; > 105% – < 130% for 30s 130% for 2s
Short-circuit behaviour	$3 \times I_N$ for 100 ms

Battery

Nominal DC voltage (intermediate circuit) 120 Vdc

DC window 102 Vdc – 160 Vdc $\pm 1\%$

Trickle charge voltage 137 Vdc $\pm 1\%$

Battery charging current (max.) 3.5 Adc per UPS module

Communication

Interfaces	RS232 (Sub-D9) RS485 (Sub-D9 / RJ45) Additionally: Communication slot for optional expansion cards (e.g. AS/400 / SNMP, etc.)
Shutdown software on CD	"CompuWatch" for all common operating systems, e.g. Windows, Linux, Mac, Unix, FreeBSD, Novell, Sun

General data

Classification	VFI SS 111 acc. to IEC 62040–3 double-conversion technology
Total efficiency AC-AC	
PROTECT 1.M (system)	> 88%
PROTECT 1.040 (module)	> 89%
Inherent noise (1m distance)	
PROTECT 1.M (system)	< 62 dB(A)
PROTECT 1.040 (module)	< 55 dB(A)
Cooling type	Forced air cooling through variable-speed fans
Operating temperature range	0 °C to +40 °C Battery systems (recommended): +15°C to +25°C
Storage temperature range	0°C to +40°C
Relative humidity	20% – 90%

Site altitude Up to 1000 m at nominal output
 Use more than 1000 m above sea level results in the following reduction in output power:

Height (m)	1000	1500	2000	2500	3000
Power	100%	95%	90%	85%	80%

Housing colour Blackline

Weight:

PROTECT 1.M (chassis) 75 kg

PROTECT 1.040 (module) 15 kg per module

Dimensions W x H x D:

PROTECT 1.M (chassis) 442 mm x 965 mm x 700 mm

PROTECT 1.040 (module) 405 mm x 87 mm x 530 mm

Directives

The PROTECT 1.M meets the product standard EN 50091.

The CE mark on the unit confirms compliance with the EC outline directives for 73/23 EEC – Low voltage and for 89/336 EEC – Electromagnetic compatibility if the installation instructions described in the operating instructions are observed.

For 73/23 EEC low-voltage directive

reference number EN 62040-1-1 : 2003

For 89/336 EMC directive

reference number EN 50091-2 : 1995

EN 61000-3-2 : 1995

EN 61000-3-3 : 1995

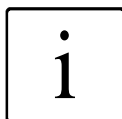

Warning:

This is a class A - device. This product can generate radio interference in the domestic environment. In this case, the user can be required to employ additional interference suppression measures.

3 Safety Regulations

3.1 Important Instructions and Explanations

The instructions for operation and maintenance as well as the following safety regulations must be complied with to ensure the safety of personnel as well as to ensure the continued availability of the unit. All personnel installing/dismantling, starting up, operating or servicing the units must be familiar with and observe these safety regulations. Only trained and qualified personnel may perform the work described, using tools, equipment, test equipment and materials intended for the purpose and in perfect working condition.

Important instructions are emphasised by the words "**Caution**", "**Attention**", "**Note**" and indented text.



Caution

This symbol identifies all working and operational procedures requiring absolute compliance to avoid any danger to persons.



Attention

This symbol identifies all working and operational procedures requiring absolute compliance to prevent any damage, irreparable or otherwise, to the unit and its components.

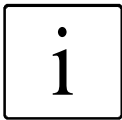

Note

This symbol identifies technical requirements and additional information requiring the operator's attention.

3.2 Accident Prevention Regulations

Compliance with the accident prevention regulations valid in the respective country of use and the general safety regulations in accordance with IEC 364 is mandatory. The following safety rules must be observed prior to performing any work on the PROTECT 1.M:

- ◆ Disconnect the unit from the power supply
- ◆ Secure the unit against being switched back on
- ◆ Verify that the unit is disconnected from the power supply
- ◆ Earth and short-circuit the unit
- ◆ Provide protection by covers or barriers for any neighbouring live parts

3.3 Qualified Personnel

The PROTECT 1.M may only be transported, installed, connected and serviced by qualified personnel who are familiar with the pertinent safety and installation regulations. All work performed must be inspected by responsible qualified personnel.

The qualified personnel must be authorised by the responsible safety officer of the installation to perform the work required.

Qualified personnel is defined as personnel

- ◆ having completed training and gained experience in the respective field,
- ◆ familiar with the pertinent standards, rules and regulations and accident prevention regulations,
- ◆ having received instruction on the mode of operation and operating conditions of the PROTECT 1.M,
- ◆ capable of recognising and preventing dangers.

Regulations and definitions for qualified personnel can be found in DIN 57105/VDE 0105, Part 1.

3.4 Safety Instructions for PROTECT 1.M



The UPS is live, and the voltage can be dangerous. **The unit may only be installed and if necessary opened by trained and qualified personnel.** Repairs may only be carried out by qualified customer service staff!



The output can be live, even when the UPS is not connected to the mains supply!



For health and safety reasons, the unit must be **earthed correctly!**

The PROTECT 1.M may only be operated with or connected to three-phase or AC voltage power systems with protective grounding using a mains connection cable with PE conductor that has been tested according to German standards (VDE).

Risk of burning!



The battery has **powerful short-circuit currents**. Incorrect connection or isolation faults can lead to melting of the plug connections, sparking potential and severe burns!



The unit has a warning signal that sounds when the battery voltage of PROTECT 1.M is exhausted or when the UPS is not working in its normal mode (see also chapter 6.1 "Signalling", page 47ff and the following).



Observe the following safety instructions to ensure permanent operational safety of and safe work with the UPS and the battery modules (special accessories):

- ◆ Do not dismantle the UPS!
(The UPS does not contain any parts that require regular maintenance. Bear in mind that the warranty will be invalidated if the unit is opened!)
- ◆ Do not install the unit in direct sunshine or in close proximity of heaters!
- ◆ The unit is designed to be installed inside in heated rooms. Never install the housing in the vicinity of water or in an excessively damp environment!
- ◆ Condensation may occur if the UPS is brought from a cold environment into the room where it is to be installed. The

UPS must be absolutely dry prior to start-up. As a result, leave it to acclimatise for at least two hours.

- ◆ Never connect the mains input and the UPS output!
- ◆ Ensure that no fluids or foreign bodies can penetrate the housing!
- ◆ Do not block the air vents of the unit! Make sure, for example, that children do not insert any objects in the ventilation openings!
- ◆ Do not connect household appliances such as hairdryers to the UPS! Also take care when working with motor loads. It is essential to avoid back-feeding the inverter, e.g. if the load is intermittently operated in regenerative mode.



Danger! Electric shocks!

Even after the mains voltage has been disconnected, the components within the UPS remain connected to the battery and can thus cause electric shocks. It is therefore imperative to disconnect the battery circuit before carrying out any maintenance or repair work!



If it is necessary to replace the battery or carry out maintenance work, this must be done by or under the supervision of a specialist familiar with batteries and the necessary safety precautions!

Only authorised persons are allowed in the vicinity of the batteries!

When replacing the batteries, the following must be observed: Only ever use identical, maintenance-free sealed lead batteries with the same data as the original batteries.



Danger! Explosive!

Never throw batteries into open fire.

Never open or damage batteries. (Electrolyte may leak out and damage skin and eyes. It may be toxic!)



Batteries can cause electric shocks and high short-circuit currents.

Therefore, take the following safety precautions when working with batteries:

- ◆ Take off watches, rings and other metallic objects!
- ◆ Only use tools with insulated handles!

3.5 CE certificate

AEG

Power Solutions

Declaration of Conformity

Document - No. CE 0064

We

AEG Power Solutions GmbH
Emil – Siepmann – Straße 32, D – 59581 Warstein

declare under our sole responsibility that the product

Uninterruptible Power Supply (UPS)
Protect I.M
type power per module 4000VA
type power UPS system 4kVA – 24 kVA

to which this declaration relates is in conformity with the following standards or other normative documents

EN 62040-1-1:2003
EN 62040-2:2006 class C2
EN 61000-3-2:2000
EN 61000-3-3:2001

Following the provisions of directives

89 / 336 / EEC	EMC Directive
73 / 23 / EEC	Low Voltage Directive
93 / 68 / EEC	Marking Directive

Year of labelling the CE – Mark: 2006

Germany, 59581 Warstein, 03.12.2008

AEG Power Solutions GmbH
Quality Management

(Filmar)

AEG Power Solutions GmbH
Product Management
Compact UPS

(Schneider)

4 Set-up

4.1 Unpacking and Inspection

The unit has been completely checked and inspected. Although the device has been packed and shipped with the usual degree of care, damage during transport cannot be ruled out completely.

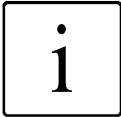

Claims for damage during transport must always be made with the transport company!

Check the shipping container for damage on arrival. If necessary, ask the transport company to check the goods and make a record of the damage in the presence of the transport company employee and report the damage to the AEG representative or dealer within eight days of delivery.

Check the delivery is complete:

- ◆ PROTECT 1.M system cabinet
- ◆ 6 slot covers for the module racks
- ◆ Slot cover cap with integrated LC display
- ◆ Communication module
- ◆ RS232 communication cable
- ◆ Management software "CompuWatch" on CD
- ◆ Operating instructions

Delivery of external (factory-fitted) battery modules includes:

- ◆ External battery unit
- ◆ Special battery connection cable
- ◆ Brief instructions with battery handling regulations

Please contact our hotline (see page 5) in case of any discrepancy.

1. Remove the packaging bands and lift up the cardboard box to remove it (see Fig. 1)

2. Remove the foam from the unit (see Fig. 2); remove the plastic wrapping;
3. Remove the lower module and the foam from the frames (see Fig. 3);
4. Now, with the assistance of at least one other person, carefully lift the system cabinet off the pallet and move it to the installation location.

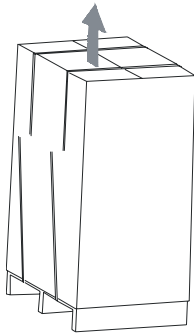

Fig. 1

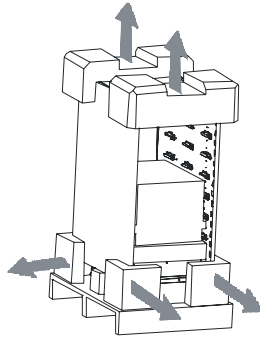

Fig. 2

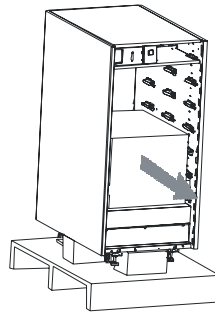

Fig. 3



Attention

Do not use a lowlift truck or forklift truck to lift the system or battery cabinet off the pallet!

The original packaging provides effective protection against mechanical shocks and should be retained so the unit can be transported safely later on.

Please keep plastic packaging bags away from babies and children in order to safeguard against suffocation accidents.

Handle the components with care. Please take into account the weight. It may be necessary to engage the help of a second person.

4.2 Transport to Installation Site

The PROTECT 1.M is equipped with transport rolls for easy transport to the intended installation site. It is recommended to install the UPS where:

- ◆ The connection work can be conveniently carried out;
- ◆ There is enough space for proper operation and, if necessary, for periodic and extraordinary maintenance work; in this regard, the connection cables should be long enough to move the UPS (to open the UPS if necessary) without having to switch it off.
- ◆ The UPS is protected against external atmospheric influences;
- ◆ The humidity and the ambient temperature are within the limits;
- ◆ The fire protection standards are observed.

The battery service life strongly depends on the ambient temperature. Ambient temperatures between +15 °C and +25 °C are optimum.



Attention!

Only transport the PROTECT 1.M **in an upright position! Never tilt or cant it;** avoid displacing the centre of gravity!

Make sure that no magnetic storage media are stored and/or operated close to PROTECT 1.M.

4.3 Set-Up

Note the following points when setting up the UPS system and its external battery units (special accessories):

- ◆ The contact surface must be smooth and level. It must also be sufficiently strong and sturdy to avoid vibration and shocks.
- ◆ Make sure that the mounting is able to support the weight, especially in conjunction with external battery units (special accessories).
- ◆ Set up the units so that adequate air circulation is assured. There must be at least 100 mm clearance at the back for ventilation purposes. Do not block the intake openings on the front and, if present, on the side of the unit. There must be a gap of at least 50 mm here.
- ◆ External battery units must be placed on the side of the UPS system. To ensure the greatest possible mechanical stability, do not place the external battery unit(s) above or below the UPS system.
- ◆ Avoid extreme temperatures! We recommend an ambient temperature of 15 °C to 25 °C in order to maximise the service life of the batteries. Do not expose the units to direct sunlight or operate them close to other heat sources such as radiators.
- ◆ Protect the units against external effects (in particular moisture and dust). In this regard, please also refer to the instructions in chapter 3, page 14 in these operating instructions.

If you transport the unit from a cold room into a warm one, or if the room temperature suddenly drops, then condensation may form inside the unit. To avoid any damage due to condensation, let the unit acclimate for 2 hours before you switch it on.

5 External View

5.1 Front and Rear View of PROTECT 1.M (chassis)

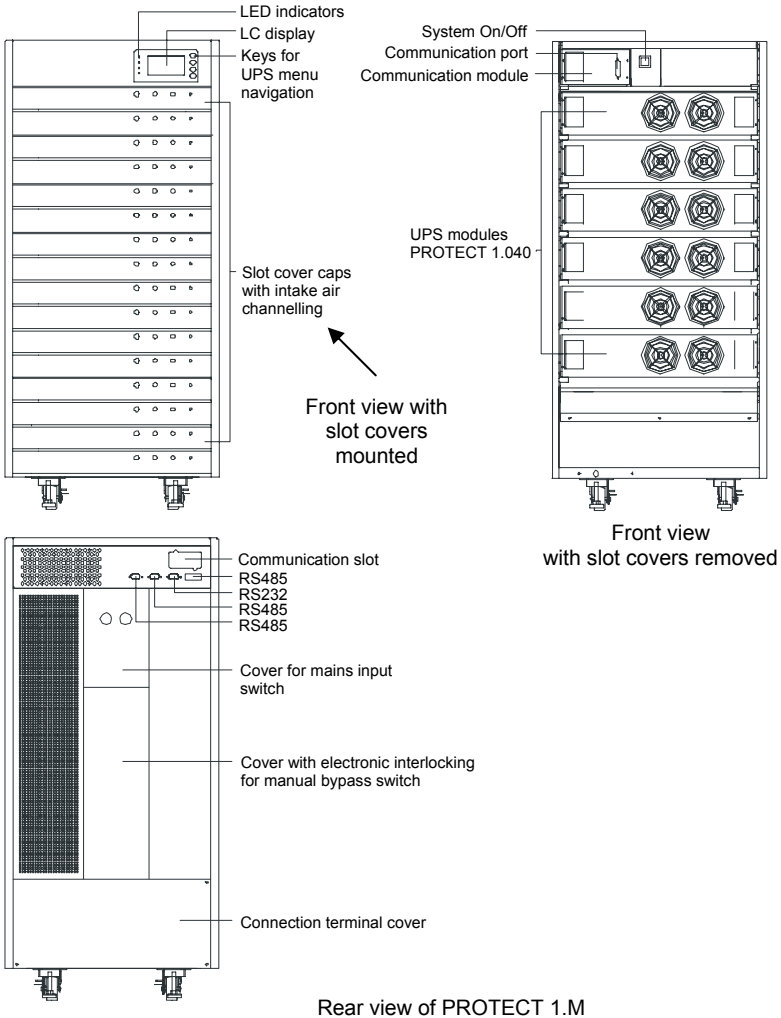

**5.2 Front/Rear and 3D View
PROTECT 1.040 (UPS module)**

5.3

Handles with latching for easy removal or insertion of a PROTECT 1.040 UPS module

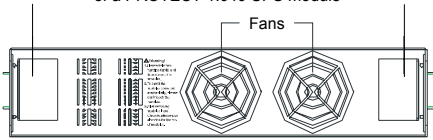

Front view

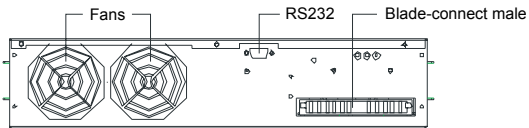

Rear view

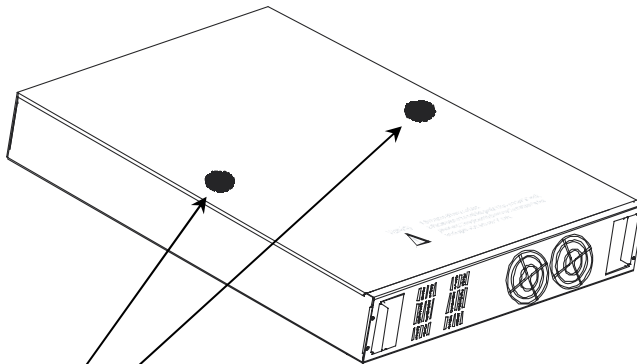

Orientation markings for optimum displacement of the centre of gravity when holding a PROTECT 1.040 UPS module

3D view

Front and Rear View (communication module)

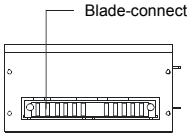

Rear view

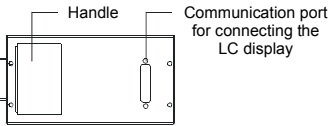

Front view

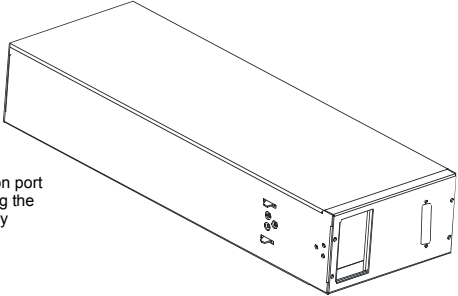

3D view

5.4 Front View of LCD Panel

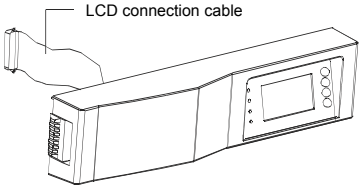

Slot cover cap with integrated LC display

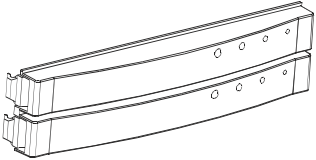

Slot cover cap for UPS modules

5.5 Display Panel



1. "Normal": The green LED lights when the UPS is supplying the loads with voltage via the inverters (normal operation).
2. "On Battery": The yellow LED lights when the UPS is supplying power from the battery.
3. "Bypass": The yellow LED lights when the UPS is supplying the loads with mains voltage from public utility's mains.
4. "Fault": If the UPS is not operating without faults, the red LED lights continuously and a continuous alarm signal sounds; alternatively, the red LED flashes and an alarm signal sounds at the same time.
5. Graphic LC display, for functions such as UPS status display
6. ↵ Select/confirm entry (return)
7. ▼ Scroll down
8. ▲ Scroll up
9. ESC: Cancel

6 Installation

6.1 Installation Notes

1. This unit must be installed by qualified personnel in accordance with the locally applicable electrical regulations.
2. The PROTECT 1.M uses fans for cooling, which means sufficient ventilation must be provided at the installation location (see also chapter 6.2: Installation area).
3. A battery system with a nominal DC voltage of 120 Vdc is required as the external battery for the PROTECT 1.M. The battery capacity and the battery pack can be selected according to the user's requirements. As an option, appropriately preconfigurations with a wide range of capacity values can be purchased directly from AEG Power Solutions.
4. Connection diagram: The PROTECT 1.M has two input modes: A single-phase input and a three-phase input. The PROTECT 1.M detects the input mode and selects the corresponding operating mode automatically.

a. Connection with single-phase input

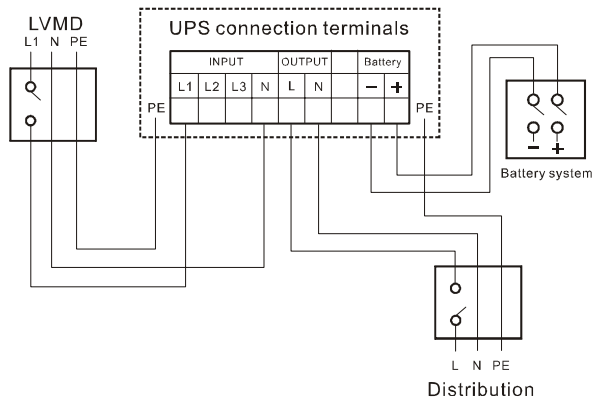

b. Connection with three-phase input

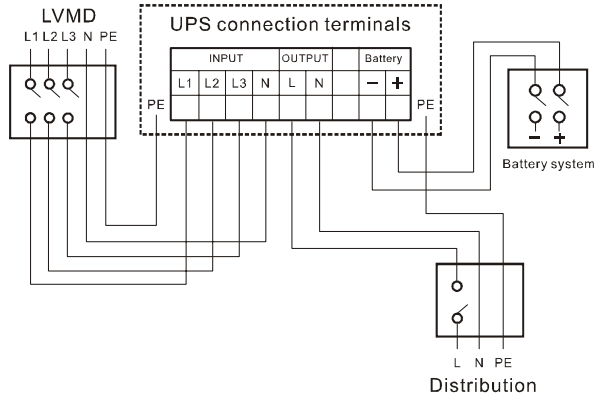

Note: If using three-phase mains connection, make sure the phase sequence is correct. The UPS cannot start up if the phase sequence is wrong, and an alarm will sound. At the same time, "Phase sequence error" appears on the LC display. Make sure the neutral conductor is connected correctly as well.

5. Installation clearances

A gap of at least 80 cm is required in front of the PROTECT 1.M and at least 30 cm behind the UPS for maintenance purposes. No objects should be placed closer than 30 cm to the side of the UPS.

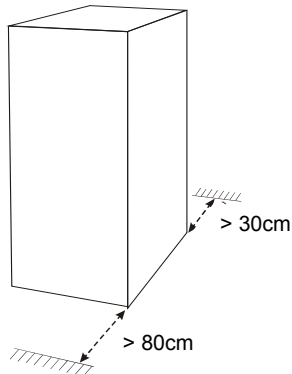

5. Connection cross-sections and fuse protection

Number of modules/ redundancy			Current values	Cross - section	Fuse protection
6 / 5	I/P 1ph~	L1	25.8A	6mm ²	32A / 230Vac
		N	25.8A		
5 / 4	I/P 3ph~	L1	25.8A	6mm ²	32A / 400Vac
L2		6.8A			
L3		6.8A			
4 / 3		N	25.8A	6mm ²	
3 / 2	AC output	L	25.8A	6mm ²	32A / 230Vac
2 / 1		N	25.8A		
1 / 0	Battery		32.7A	6mm ²	50A / 125Vdc
6 / 4	I/P 1ph~	L1	51.6A	10mm ²	63A / 230Vac
		N	51.6A		
5 / 3	I/P 3ph~	L1	51.6A	10mm ²	63A / 400Vac
L2		13.5A			
L3		13.5A			
4 / 2		N	51.6A	10mm ²	
3 / 1	AC output	L	51.6A	10mm ²	63A / 230Vac
2 / 0		N	51.6A		
	Battery		65.4A	16mm ²	80A / 125Vdc
6 / 3	I/P 1ph~	L1	77.4A	16mm ²	80A / 230Vac
		N	77.4A		
5 / 2	I/P 3ph~	L1	77.4A	16mm ²	80A / 400Vac
L2		20.3A			
L3		20.3A			
4 / 1		N	77.4A	16mm ²	
3 / 0	AC output	L	77.4A	16mm ²	80A / 230Vac
		N	77.4A		
	Battery		96.9A	25mm ²	125A / 125Vdc

Number of modules/ redundancy			Current values	Cross - section	Fuse protection
6 / 2 5 / 1 4 / 0	I/P 1ph~	L1	103.2A	35mm ²	125A / 230Vac
		N	103.2A		
	I/P 3ph~	L1	103.2A	35mm ²	125V / 400Vac
		L2	27.1A		
		L3	27.1A		
		N	103.2A	35mm ²	
	AC output	L	103.2A	35mm ²	125A / 230Vac
		N	103.2A		
Battery			130.7A	35mm ²	160A / 125Vdc
6 / 1 5 / 0	I/P 1ph~	L1	129.0A	35mm ²	160A / 230Vac
		N	129.0A		
	I/P 3ph~	L1	129.0A	35mm ²	160A / 400Vac
		L2	33.8A		
		L3	33.8A		
		N	129.0A	35mm ²	
	AC output	L	129.0A	35mm ²	160A / 230Vac
		N	129.0A		
Battery			163.4A	50mm ²	200A / 125Vdc
6 / 0	I/P 1ph~	L1	154.8A	50mm ²	160A / 230Vac
		N	154.8A		
	I/P 3ph~	L1	154.8A	50mm ²	160A / 400Vac
		L2	40.6A		
		L3	40.6A		
		N	154.8A	50mm ²	
	AC output	L	154.8A	50mm ²	160A / 230Vac
		N	154.8A		
Battery			196.1A	50mm ²	250A / 125Vdc

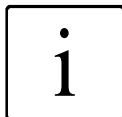

If you are using fuse load break switch for mains fusing, please select miniature circuit breakers with "D" characteristic.

Route wires individually to guarantee reliable strain relief.

Preferably use special rubber-insulated wire
NSGAÖU or NSGAFÖU, NYY or Radox 4GKW-AX.

6.2 Set-up and Installation of the Modules

1. To set up the unit, position it in its installation location and use a spanner to turn the height-adjustable feet until they reach the floor. The feet are located at the four corners of the baseplate.

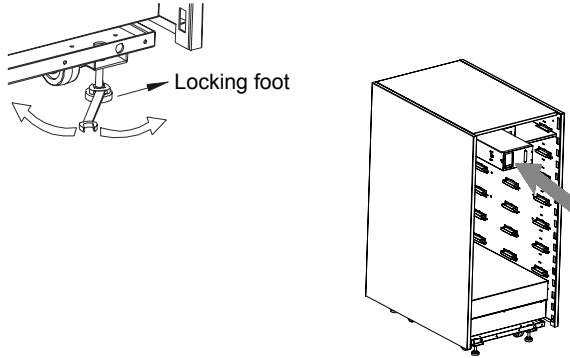

2. Push the communication module into the top left-hand corner of the uppermost slot (see illustration above).
3. Push all PROTECT 1.040 UPS modules into the slots one after the other in order to complete installation of the modules (see illustrations below).

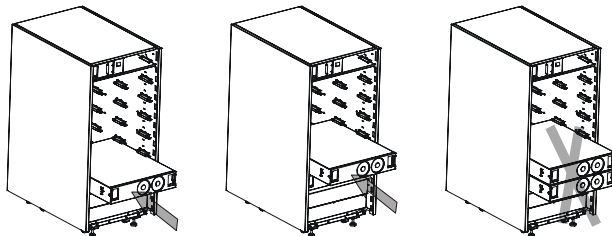

Note: You must install the modules one after the other. Only once one module has been engaged completely in the frame can the next one be installed.

Hold the UPS module firmly at the sides when pushing it in. Your thumbs should make contact with the orientation marks on the UPS module (see illustration below).

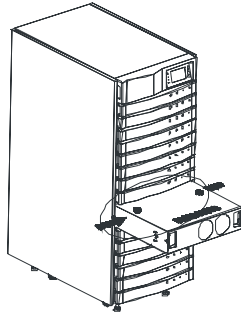

4. Install the slot cover caps: Insert the slot cover caps from bottom to top over each individual slot. To ensure optimum cooling of the individual UPS modules, continuous operation is only permitted with the slot cover caps in place.

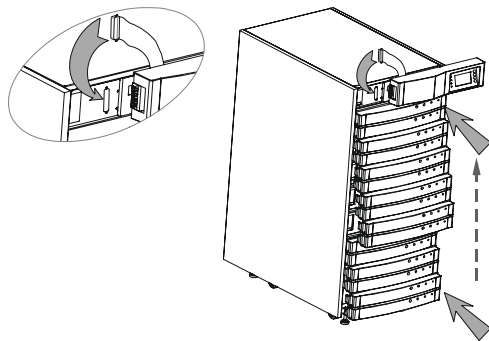

5. Install the LC display: Connect the plug of the LC display ribbon cable to the communication port on the front of the communication module. Fix it in place using the screws provided. Then engage the display in the top rack on the front of the unit.

7 Adding/Removing Modules

7.1 Active Redundancy

n+x technology is one of the most reliable configurations. "n" represents the minimum number of PROTECT 1.040 UPS modules that requires the total power; "x" represents the number of redundant PROTECT 1.040 UPS modules, i.e. the number of fault-tolerant modules that the system can handle at the same time. Assume the apparent output power to be achieved is 15 kVA, for example. One module of the PROTECT 1.M delivers 4 kVA. This means it is necessary to select n=4 at least ($4 \times 4 \text{ kVA} = 16 \text{ kVA}$). If $x = 2$ then two additional UPS modules would provide active redundancy.

In the sample configuration above, each of the 6 UPS modules delivers a 2.5 kVA proportion of the overall power. If one module were to fail, the five other modules would each deliver 3 kVA. If two UPS modules fail, the remaining four modules would each deliver 3.75 kVA. The system indicated here therefore permits a maximum of two modules to fail, although the probability of two modules failing simultaneously is considerably lower than that of one module failing. Furthermore, additional modules guarantee that the overall system has a higher overload capacity, for instance.

You can increase capacity by adding to the number of modules in the PROTECT 1.M. Do this by connecting from one to six modules in parallel. The six UPS modules function autonomously and are independent of one another. Faulty modules can easily be renewed during ongoing operation at any time.

7.2 Installing and Removing UPS Modules

The PROTECT 1.M uses what is referred to as hot-swappable technology, which means you can install or uninstall, add or remove modules irrespective of whether the unit is switched on or off. If the UPS is operating with loads, before removing any modules you should check that the remaining modules are capable of providing sufficient power otherwise there may be an overload.

7.2.1 Basic procedure for installing a PROTECT 1.040 UPS module

1. Remove the slot cover cap from the rack in which the UPS module is going to be installed.
2. Grip the UPS module at the sides with both hands. The black dots on the top of the UPS module serve as orientation marks for where to position your thumbs in order to have the centre of gravity in the optimum position. Slowly and carefully push the module into the housing slot. Make sure that the warning notice is facing upwards.
3. Make sure that the module has been completely pushed into the shaft and has clipped in with a clearly audible "click".
4. Reinstall the cover plate.

7.2.2 Basic procedure for removing a PROTECT 1.040 UPS module

1. Remove the slot cover cap from the rack from which the UPS module is going to be removed. Use both hands to pull the handles on the sides. Pull until you see the "●" markings on the top of the UPS module you are pulling out (the handle has a detent position, and only when the lever is pressed is it possible to pull the module out).
2. Then hold the module with both hands with your thumbs at the "●" markings and pull it out.

Note: Pull the module slowly and without exerting too much force. In particular, watch out for the shift in the centre of gravity when the module leaves the slot!

8 Operating and Maintenance

8.1 Operation

1. Make sure that the phase sequence is correct if you are using a three-phase mains connection (L1, L2, L3). If you are using a single-phase mains connection, make sure that phase L1 has been selected and correctly connected to the UPS.
2. Furthermore, make sure that the neutral conductor has been connected properly and that the system is adequately earthed.
3. Check the polarity of the battery system. Make sure that the (+) and (-) poles of the connection match those of the battery casing. Now switch the battery system "ON" using the fuse load break switch.
4. Switch the input protection switch on the rear of the UPS to "ON". The fans start operating immediately.
5. Now set the "system start switch" behind the slot cover cap of the LC display to "ON" and follow the instructions on the LC display.

Note: The diagrams below show examples for the displays with a three-phase connection for the UPS; in spite of the slight differences they also apply accordingly to the AC voltage connection. The content of the diagrams is only intended for display purposes.

1) After step 4.

2) Wait about 15 seconds

IMPORTANT: Step 5 only now.

LCD SELFTESTING ...

PT1.M UPS
UPS SELFTESTING
PLEASE WAIT A MOMENT

→ UPS ON
SETUP
INQUIRE

3) Press ESC

LOAD: 0% BATT: 137
I / P VOLT: 232 232 231
O / P VOLT: 0
O / P FREQ: 0.0Hz
STATUS: NO OUTPUT

4) Press ▼ for the following information

OUTPUT PARAMETER		
RN	SN	TN
VOLT: 0V		
CURR: 0A		
FREQ: 0.0Hz		

Note: When the mains is connected for the first time, the UPS does not output any voltage (Figs. correspond to this status)

5) Press ▼ again
for the following information

INPUT PARAMETER			
RN	SN	TN	
VOLT: 232	232	231	
FREQ: 50.0Hz			
RST INPUT			

6) Press ▼ again
for the following inform.

POWER PARAMETER	
kW	kVA
TOTAL: 0.00	0.00
UPS1: 0.00	0.00
UPS2: 0.00	0.00

Note: The status of each UPS module is displayed cyclically in the bottom two lines.

7) Press the ▼ key again for the following information

BATTERY PARAMETER
BAT VOLT: 136V
VOLUME: 100%
STATUS: CHARGING

Note: Battery status is CHARGING, DISCHARGE or BATT OPEN (battery not connected).

8.1.1 Start-up

1) Switch on

2) Press the
↵ / Return key

3) Press the
▼ key

→ UPS ON
SETUP
INQUIRE

CONFIRM
TURN UPS ON
→ NO, CANCEL
YES, CONFIRM

4) Once again, press the
↵ / Return key

UPS IS TURNING ON

PLEASE WAIT...

LOAD: 0% BATT: 136
I / P VOLT: 232 232 231
O / P VOLT: 230
O / P FREQ: 50.0Hz
STATUS: 3 PHASE I / P

8.1.2 Shutting down

1) Switch off

2) Press the
↵ / Return key

3) Make selection

→ UPS OFF
SELFTEST
INQUIRE

UPS OFF SELECTION
→ SWITCH TO BYPASS
TURN OFF OUTPUT

3) Switch-off option 1:
Load supply via bypass
"SWITCH TO BYPASS"

CONFIRM
SWITCH TO BYPASS
→ NO, CANCEL
YES, CONFIRM

4) Switch-off option 2:
Load supply directly off
"TURN OFF OUTPUT"

CONFIRM
WARNING:
OUTPUT OFF
→ NO, CANCEL
YES, CONFIRM

5) Select "YES, CONFIRM" and
press the ↵ / Return key again

TURNING OFF

PLEASE WAIT...

UPS IS OFF

PRESS ANY KEY...

8.1.3 Inquiries

1) Menu inquiries 2) Press the ↵ / Return key

UPS ON
SETUP
→ INQUIRE

INQUIRY
→ PHONE
MAINTAIN PROCEDURE
ALARM CONTROL
ONLY FOR SERVICE

3) Press the ↵ / Return key at the "PHONE" item, for example

```
RETAILER PHONE:
XXXXXXXXXXXXXX
XXXXXXXXXXXXXX
```

8.1.4

Setup

(press ESC to exit the aforementioned menus)

The user can enter the User Setup menu by entering the password (the initial password is "1234" and should be changed by the user) and set the following parameters (UPS in BYPASS mode!):

1) Setup menu

(not in Start-up menu)

2) Press the ▼ key

```
→UPS ON
  SETUP
    INQUIRE
```

```
UPS ON
→ SETUP
  INQUIRE
```

3) Enter the password;

press the ↵ / Return key

4) Select the

required setting

```
→ USER KEY: *****
```

```
SETUP
→ SELFTEST  TIME
  RE-START  REDUNDAN
  PASSWORD  VOLTAGE
  PHONE     FREQUEN
```

5) Select SETUP,
e.g. REDUNDAN and
press ↵ / Return

6) E.g. if the number of
redundant modules is 0, ...

```
SETUP REDUNDANCE
TOTAL NUM: 3
→REDUN NUM: 1
MAX POWER CURRENT
SETTING: 8kVA/5.6kW
```

```
WARNING:
CURRENT SETTING IS
NO REDUNDANCY, OK?

YES → NO
```

The redundancy setup applies after the Setup menu is exited, i.e. the UPS displays "Overload" if the power is more than 8 kVA / 5.6 kW.

7) Switch on the PROTECT 1.M in battery mode:

Having ensured that the batteries are connected correctly, switch the battery fuse-switch disconnecter to "ON". Then press the system switch (located behind the LC display) from "OFF" to "ON". The displayed menu is similar to that of mains current mode. Now switch on the UPS. The UPS switches off if you do not start any action within 15 seconds; the LC display is switched off after about 10 minutes: "NO MODULE DETECTED"



Observe the safety precaution!

For personal safety reasons, do not switch on the UPS when the mains is disconnected!

8.2 Maintenance

1. Maintenance of the UPS and battery replacement should be performed by well trained expert personnel.
2. Batteries that have not been used for some time must be charged up every three months at normal ambient temperature and every two months if the ambient temperature is high.
3. The three switches on the back, from top to bottom, are as follows: Mains fuse-switch disconnect, manual service bypass switch and output switch. Switching the mains fuse-switch disconnect on causes mains voltage to be supplied to each module of the PROTECT 1.M. Switching the output switch on allows output voltage to be delivered from the modules of the UPS to the loads. The maintenance switch is used for UPS maintenance. The UPS can only run in inverter operation if the manual service bypass switch is switched off and the cover has been fitted.

Note: Make sure that the PROTECT 1.M has been changed over to bypass operation before you switch on the manual service bypass switch. The load connection is immediately supplied with voltage when the manual service bypass switch is actuated. Only trained and qualified personnel should operate this switch.

8.3 Shutdown and UPS Management Software

The "CompuWatch" software specially developed for these purposes by AEG continuously checks the mains supply and the UPS status.

In conjunction with the "intelligent" UPS, this guarantees the availability of the EDP components as well as the data security.

The "CompuWatch" shutdown software supports different operating systems, e.g. Windows 98SE/ME, Windows NT/2000/XP, Windows Vista, Linux SUSE, Linux RedHat, Novell Netware, IBM AIX, HP-UX, SUN Solaris, Mac OS, and others.

Example of a "CompuWatch" screen:

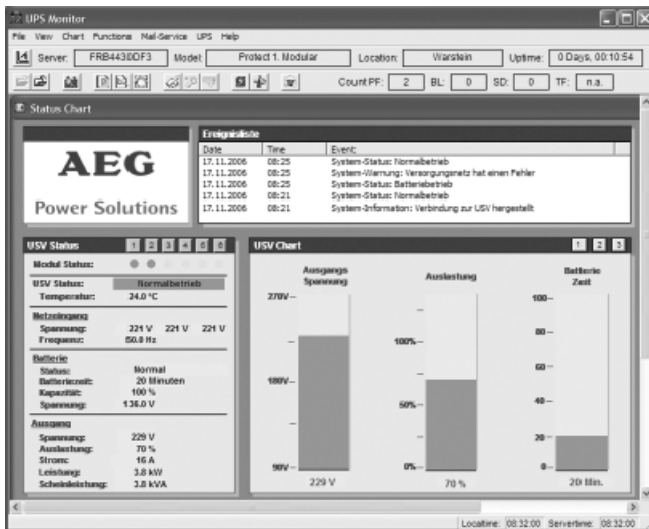

Refer to the manual on the CD for details about installing the software on the various operating systems. Download of updates at www.AEGpartnerNet.com >> PRODUCTS >> Software >> CompuWatch.

9 Communication Interfaces

The PROTECT 1.M has RS232 and RS485 interfaces as well as an expansion slot: As external connections, it is possible to use either an AS400 card (optional) or an SNMP/ SNMP PRO card (optional) for the expansion slot.

1. The standard RS232 interface is for the "CompuWatch" control software.
2. The RS485 connection makes it possible to monitor and control all the functions of the UPS from a remote location.
3. The optional AS400 connection is for AS400 users who want to control the UPS directly by using the UPS control function of the AS400 system.
4. In addition, the expansion slot is for the SNMP/ SNMP PRO card (optional accessory), which permits remote monitoring of the UPS via the Internet.
5. If you have any questions about using the aforementioned communication interface connections, please contact our customer support.

10 Troubleshooting and Fault Rectification

If error messages are displayed, please refer to the following table in order to localise the fault that has occurred and to find information about what measures to take to rectify the fault. If you cannot resolve the problem(s), please contact the Service Center (see page 5 "Hotline").

1. Check whether the UPS connection, and specifically the mains connection, has been made correctly.
2. Check whether the input voltage has been applied correctly (check for phase(s) connected to the neutral conductor and for the phase sequence, if appropriate).
3. Check the connection of the battery system (polarity and nominal voltage).
4. Make a note of the status of the unit when the fault occurred (LC display) and the error code number that is displayed.

Overview of fault messages		
PROBLEM	POSSIBLE CAUSE	SOLUTION
Error/fault LED lights up, periodic warning signals	Overload in normal / bypass or battery operation	Reduce the load.
	Applied mains not in tolerance range	Check whether input cabling and UPS input voltage are normal.
	Battery system faulty / not connected	Check whether the voltage of the battery system is correct and that the battery fuse-switch disconnector is made.
Error/fault LED lights up, continuous warning signal	UPS fault	Contact the Customer Service Center.
Battery discharge time is 1/3 shorter compared to 1sttime	Battery system aged/reached end of useful life	
	Charging error	
LC display dark or faulty	LCD displays that data cable is not attached correctly (?)	Make sure that the communication module has been installed correctly; check both plugs of the ribbon cable for the LC display are connected correctly.
CompuWatch or SNMP(pro) do not detect the PROTECT 1.M >> No communication	Software status of CompuWatch or firmware of SNMP(pro) card outdated; error in computer configuration	Download the latest software / firmware from the AEG homepage. Check the communication cable.
The LC display does not display any inserted UPS modules	Modules, housing or units are not connected correctly.	Pull the module out and re-insert it into the slot (click!) or use a different slot.
Mains power is connected but the UPS does not start operating.	Mains not in tolerance; phase loss or possible phase sequence error; cover removed from bypass switch.	Check the mains voltage and UPS connection; replace cover of bypass switch if removed.

11 Reference Table for the Display and UPS Operating Problems

11.1 Normal operation

Operating status / Operating problems	LED indications				Warning signal	LC displays	Notes
	Normal (Normal)	Battery (On Battery)	Bypass (Fault)	Fault (Fault)			
Mains in tolerance range	✱				None		
Mains not in tolerance, i.e. batt. operation	✱	✱		✱✱	1 acoustic signal every 4s	"utility power is abnormal"	

11.2 Battery Operation

Battery voltage in tolerance range	✱	✱		✱✱	1 acoustic signal every 4s	"utility power is abnormal"	
Battery voltage not in tolerance range	✱	✱✱		✱✱	1 acoustic signal every 2s	"battery voltage is too low"	Check battery system; poss. Reduce load

11.3 Bypass Operation

Operating status / Operating problems	LED indications				Warning signal	LC displays	Notes
	Normal (Normal)	Battery (On Battery)	Bypass (Fault)	Fault (Fault)			
Mains in tolerance range; bypass mode			✱	✱✱	1 acoustic signal every 2 min.		Alarm stops when UPS returns to normal mode
Mains not in tolerance range; bypass mode				✱✱	1 acoustic signal every 4 s	"utility power is abnormal"	USV/output voltage is switched off

11.4 Warning Signal if Battery System Not Connected, e.g. battery fuse failure

Operating status / Operating problems	LED indications				Warning signal	LC displays	Notes
	Normal (Normal)	Battery (On Battery)	Bypass (Fault)	Fault (Fault)			
Bypass mode			✱	⋯	1 acoustic signal every 4 s	"UPS is not connected to the battery"	Check battery system; poss. fuse fault?
Normal mode	✱			⋯	1 acoustic signal every 4 s	"UPS is not connected to the battery"	Check battery system; poss. fuse fault?

11.5 Warning Signal for Phase Loss or Phase Sequence Error

Operating status / Operating problems	LED indications				Warning signal	LC displays	Notes
	Normal (Normal)	Battery (On Battery)	Bypass (Fault)	Fault (Fault)			
Phase loss; Phase sequence error; bypass				⋯	1 acoustic signal every 2 s	"utility failure and sequence error"	No output voltage; check UPS connection
Mains failure normal mode	✱	✱		⋯	1 acoustic signal every 4 s	"utility failure" alarm code 02 03 09	Check UPS input cabling

Note: ✱ = LED lights up

⋯ = LED flashes

11.6 Overload Protection

Operating status / Operating problems	LED indications				Warning signal	LC displays	Notes
	Normal (Normal)	Battery (On Battery)	Bypass (Fault)	Fault (Fault)			
Overload in normal operation UPS warning	✱			⋯	1 acoustic signal every 2 s	"Output overload"	Reduce the load
Overload in normal operation > Switchover			✱	✱	Continuous warning signal	"Output overload" Alarm code: 46	Reduce the load
Overload in battery operation UPS warning	✱	✱		⋯	1 acoustic signal every 2 s	"Output overload"	Reduce the load
Overload in battery operation > switch-off	✱	✱		✱	Continuous warning signal	"Output overload" Alarm code: 46	Reduce the load
Overload in bypass operation			✱	⋯	1 acoustic signal every 2 s	"Output overload"	Reduce the load

Note: ✱ = LED lights up

⋯ = LED flashes



If you cannot solve the problem that has occurred, stop the entire procedure, switch off the UPS and disconnect the UPS from the mains. Please contact our hotline in this case (see page 5).

Please have the serial number of the unit as well as the purchase date at hand. The hotline will provide you with technical support and can inform you about further procedures once you have described the problem.

12 Minimum Number of Battery Packs

Batteries with different capacity have specific charging and discharging characteristics. Standard configurations have been defined in order to make optimum use of the service life. The hatched part shows the permitted configurations.

Configuration table for battery cabinet systems equipped with 24 or 28 Ah battery blocks

Power	24/28 Ah x1	24/28 Ah x2	24/28 Ah x3	24/28 Ah x4	24/28 Ah x5	24/28 Ah x6
4 kVA						
8 kVA						
12 kVA						
16 kVA						
20 kVA						
24 kVA						

Configuration table for battery cabinet systems equipped with 38 or 42 Ah battery blocks

Power	38/42 Ah x1	38/42 Ah x2	38/42 Ah x3	38/42 Ah x4	38/42 Ah x5	38/42 Ah x6
4 kVA						
8 kVA						
12 kVA						
16 kVA						
20 kVA						
24 kVA						

Configuration table for battery cabinet systems equipped with 65 or 75 Ah battery blocks

Power	65/75 Ah x1	65/75 Ah x2	65/75 Ah x3	65/75 Ah x4	65/75 Ah x5	65/75 Ah x6
4 kVA						
8 kVA						
12 kVA						
16 kVA						
20 kVA						
24 kVA						

The following tables show the achievable standby times according to the UPS expansion level and capacity utilisation as well as depending on the optional battery cabinet units that are connected ex-works:

PROTECT 1.M at part load level		< < < < AUTONOMY TIME > > > >			
		25% load 2 kVA = 1400 W	50% load 4 kVA = 2800 W	75% load 6 kVA = 4200 W	100% load 8 kVA = 5600 W
PROTECT 1.M 8 kVA Components of the system cabinet with 2 modules PROTECT 1.040	with 1 x PROTECT 1.M BP28	84.0 min.	40.0 min.	24.5 min.	15.5 min.
	with 1 x PROTECT 1.M BP56	186.0 min.	87.0 min.	62.0 min.	41.5 min.
	with 1 x PROTECT 1.M BP42	129.5 min.	56.5 min.	38.5 min.	28.0 min.
	with 1 x PROTECT 1.M BP84	306.5 min.	140.5 min.	81.0 min.	58.5 min.
	with 1 x M BP84 + 1 x M BP42	517.0 min.	234.5 min.	142.5 min.	94.5 min.
	with 2 x PROTECT 1.M BP84	712.0 min.	335.5 min.	195.5 min.	146.0 min.
	with 2 x M BP84 + 1 x M BP42	942.0 min.	456.5 min.	272.0 min.	179.5 min.
	with 3 x PROTECT 1.M BP84	1095.5 min.	544.5 min.	340.5 min.	246.0 min.
	with 1 x PROTECT 1.M BP65	211.5 min.	86.0 min.	58.0 min.	36.5 min.
	with 2 x PROTECT 1.M BP65	504.5 min.	227.0 min.	146.0 min.	77.0 min.
with 3 x PROTECT 1.M BP65	826.0 min.	383.0 min.	230.0 min.	168.5 min.	
with 4 x PROTECT 1.M BP65	1108.0 min.	532.5 min.	319.5 min.	235.5 min.	
with 5 x PROTECT 1.M BP65	1337.0 min.	679.5 min.	449.0 min.	297.5 min.	
with 6 x PROTECT 1.M BP65	1540.0 min.	892.0 min.	538.0 min.	403.5 min.	
Explanation: (basics of battery calculation)	PROTECT 1.M BP28 loaded with 1 x 10 battery blocks; Type: Panasonic "LC-X1228" PROTECT 1.M BP56 loaded with 2 x 10 battery blocks; Type: Panasonic "LC-X1228" PROTECT 1.M BP42 loaded with 1 x 10 battery blocks; Type: Panasonic "LC-X1242" PROTECT 1.M BP84 loaded with 2 x 10 battery blocks; Type: Panasonic "LC-X1242" PROTECT 1.M BP65 loaded with 1 x 10 battery blocks; Type: Panasonic "LC-X1265"				

PROTECT 1.M at part load level		< < < < AUTONOMY TIME > > > >			
		25% load 3 kVA = 2100 W	50% load 6 kVA = 4200 W	75% load 9 kVA = 6300 W	100% load 12 kVA = 8400 W
PROTECT 1.M 12 kVA Components of the system cabinet with 3 modules PROTECT 1.040	with 1 x PROTECT 1.M BP28	-----	-----	-----	-----
	with 1 x PROTECT 1.M BP56	115.5 min.	61.0 min.	34.5 min.	25.5 min.
	with 1 x PROTECT 1.M BP42	75.0 min.	35.5 min.	23.5 min.	15.0 min.
	with 1 x PROTECT 1.M BP84	175.5 min.	80.0 min.	51.0 min.	39.5 min.
	with 1 x M BP84 + 1 x M BP42	306.5 min.	140.5 min.	81.0 min.	58.5 min.
	with 2 x PROTECT 1.M BP84	458.5 min.	191.0 min.	121.0 min.	83.0 min.
	with 2 x M BP84 + 1 x M BP42	564.0 min.	268.5 min.	159.5 min.	113.5 min.
	with 3 x PROTECT 1.M BP84	712.0 min.	335.5 min.	195.5 min.	146.0 min.
	with 1 x PROTECT 1.M BP65	133.0 min.	55.0 min.	29.5 min.	19.5 min.
	with 2 x PROTECT 1.M BP65	289.5 min.	144.0 min.	80.0 min.	63.5 min.
with 3 x PROTECT 1.M BP65	504.5 min.	222.5 min.	146.0 min.	88.0 min.	
with 4 x PROTECT 1.M BP65	684.5 min.	312.5 min.	199.5 min.	150.0 min.	
with 5 x PROTECT 1.M BP65	938.5 min.	443.0 min.	259.0 min.	187.5 min.	
with 6 x PROTECT 1.M BP65	1108.0 min.	532.5 min.	319.5 min.	235.5 min.	
Explanation: (basics of battery calculation)	PROTECT 1.M BP28 loaded with 1 x 10 battery blocks; Type: Panasonic "LC-X1228" PROTECT 1.M BP56 loaded with 2 x 10 battery blocks; Type: Panasonic "LC-X1228" PROTECT 1.M BP42 loaded with 1 x 10 battery blocks; Type: Panasonic "LC-X1242" PROTECT 1.M BP84 loaded with 2 x 10 battery blocks; Type: Panasonic "LC-X1242" PROTECT 1.M BP65 loaded with 1 x 10 battery blocks; Type: Panasonic "LC-X1265"				

PROTECT 1.M at part load level		<<<< AUTONOMY TIME >>>>				
		25% load 4 kVA = 2800 W	50% load 8 kVA = 5600 W	75% load 12 kVA = 8400 W	100% load 16 kVA = 11200 W	
PROTECT 1.M 16 kVA	Components of the system cabinet with 4 modules PROTECT 1.040	with 1 x PROTECT 1.M BP28	-----	-----	-----	-----
		with 1 x PROTECT 1.M BP56	84.0 min.	40.0 min.	24.5 min.	15.5 min.
		with 1 x PROTECT 1.M BP42	-----	-----	-----	-----
		with 1 x PROTECT 1.M BP84	129.5 min.	56.5 min.	38.5 min.	28.0 min.
		with 1 x M BP84 + 1 x M BP42	212.5 min.	89.0 min.	57.0 min.	43.5 min.
		with 2 x PROTECT 1.M BP84	306.5 min.	140.5 min.	81.0 min.	58.5 min.
		with 2 x M BP84 + 1 x M BP42	423.5 min.	175.0 min.	109.5 min.	77.5 min.
		with 3 x PROTECT 1.M BP84	517.0 min.	234.5 min.	142.5 min.	94.5 min.
		with 1 x PROTECT 1.M BP65	-----	-----	-----	-----
		with 2 x PROTECT 1.M BP65	211.5 min.	86.0 min.	58.0 min.	36.5 min.
		with 3 x PROTECT 1.M BP65	346.5 min.	163.5 min.	87.0 min.	70.0 min.
		with 4 x PROTECT 1.M BP65	504.5 min.	227.0 min.	146.0 min.	88.0 min.
with 5 x PROTECT 1.M BP65	600.0 min.	288.5 min.	181.0 min.	138.5 min.		
with 6 x PROTECT 1.M BP65	826.0 min.	383.0 min.	230.0 min.	168.5 min.		

Explanation:
(basics of battery calculation)

PROTECT 1.M BP28 loaded with 1 x 10 battery blocks; Type: Panasonic "LC-X1228"
PROTECT 1.M BP56 loaded with 2 x 10 battery blocks; Type: Panasonic "LC-X1228"
PROTECT 1.M BP42 loaded with 1 x 10 battery blocks; Type: Panasonic "LC-X1242"
PROTECT 1.M BP84 loaded with 2 x 10 battery blocks; Type: Panasonic "LC-X1242"
PROTECT 1.M BP65 loaded with 1 x 10 battery blocks; Type: Panasonic "LC-X1265"

PROTECT 1.M at part load level		<<<< AUTONOMY TIME >>>>				
		25% load 5 kVA = 3500 W	50% load 10 kVA = 7000 W	75% load 15 kVA = 10500 W	100% load 20 kVA = 14000 W	
PROTECT 1.M 20 kVA	Components of the system cabinet with 5 modules PROTECT 1.040	with 1 x PROTECT 1.M BP28	-----	-----	-----	-----
		with 1 x PROTECT 1.M BP56	-----	-----	-----	-----
		with 1 x PROTECT 1.M BP42	-----	-----	-----	-----
		with 1 x PROTECT 1.M BP84	89.5 min.	44.5 min.	29.5 min.	21.0 min.
		with 1 x M BP84 + 1 x M BP42	160.0 min.	71.0 min.	47.0 min.	35.0 min.
		with 2 x PROTECT 1.M BP84	235.5 min.	100.0 min.	60.5 min.	46.5 min.
		with 2 x M BP84 + 1 x M BP42	306.5 min.	140.5 min.	81.0 min.	58.5 min.
		with 3 x PROTECT 1.M BP84	599.0 min.	169.0 min.	102.5 min.	74.0 min.
		with 1 x PROTECT 1.M BP65	-----	-----	-----	-----
		with 2 x PROTECT 1.M BP65	164.0 min.	72.0 min.	38.0 min.	26.5 min.
		with 3 x PROTECT 1.M BP65	260.5 min.	124.5 min.	73.0 min.	44.0 min.
		with 4 x PROTECT 1.M BP65	385.0 min.	173.0 min.	92.0 min.	74.5 min.
with 5 x PROTECT 1.M BP65	504.5 min.	227.0 min.	146.0 min.	88.0 min.		
with 6 x PROTECT 1.M BP65	584.0 min.	277.5 min.	174.5 min.	131.0 min.		

Explanation:
(basics of battery calculation)

PROTECT 1.M BP28 loaded with 1 x 10 battery blocks; Type: Panasonic "LC-X1228"
PROTECT 1.M BP56 loaded with 2 x 10 battery blocks; Type: Panasonic "LC-X1228"
PROTECT 1.M BP42 loaded with 1 x 10 battery blocks; Type: Panasonic "LC-X1242"
PROTECT 1.M BP84 loaded with 2 x 10 battery blocks; Type: Panasonic "LC-X1242"
PROTECT 1.M BP65 loaded with 1 x 10 battery blocks; Type: Panasonic "LC-X1265"

PROTECT 1.M at part load level		<<<< AUTONOMY TIME >>>>				
		25% load 6 kVA = 4200 W	50% load 12 kVA = 8400 W	75% load 18 kVA = 12600 W	100% load 24 kVA = 16800 W	
PROTECT 1.M 24 kVA	Components of the system cabinet with 6 modules PROTECT 1.040	with 1 x PROTECT 1.M BP28	-----	-----	-----	-----
		with 1 x PROTECT 1.M BP56	-----	-----	-----	-----
		with 1 x PROTECT 1.M BP42	-----	-----	-----	-----
		with 1 x M BP84 + 1 x M BP42	75.0 min.	38.0 min.	23.5 min.	15.0 min.
		with 2 x PROTECT 1.M BP84	129.5 min.	56.5 min.	38.5 min.	28.0 min.
		with 2 x M BP84 + 1 x M BP42	166.5 min.	80.0 min.	51.0 min.	39.5 min.
		with 3 x PROTECT 1.M BP84	249.5 min.	107.5 min.	64.5 min.	48.5 min.
		with 3 x M BP84 + 1 x M BP42	306.5 min.	140.5 min.	81.0 min.	58.5 min.
		with 1 x PROTECT 1.M BP65	-----	-----	-----	-----
		with 2 x PROTECT 1.M BP65	133.0 min.	55.0 min.	29.5 min.	19.5 min.
		with 3 x PROTECT 1.M BP65	213.0 min.	86.0 min.	58.0 min.	36.5 min.
		with 4 x PROTECT 1.M BP65	289.5 min.	144.0 min.	80.0 min.	61.0 min.
with 5 x PROTECT 1.M BP65	409.0 min.	179.0 min.	106.0 min.	77.5 min.		
with 6 x PROTECT 1.M BP65	504.5 min.	227.0 min.	146.0 min.	88.0 min.		

Explanation:
(basics of battery calculation)

PROTECT 1.M BP28 loaded with 1 x 10 battery blocks; Type: Panasonic "LC-X1228"
PROTECT 1.M BP56 loaded with 2 x 10 battery blocks; Type: Panasonic "LC-X1228"
PROTECT 1.M BP42 loaded with 1 x 10 battery blocks; Type: Panasonic "LC-X1242"
PROTECT 1.M BP84 loaded with 2 x 10 battery blocks; Type: Panasonic "LC-X1242"
PROTECT 1.M BP65 loaded with 1 x 10 battery blocks; Type: Panasonic "LC-X1265"

13 List of terms

13.1 Technical terminology

DC/DC booster	Circuit technology for increasing a DC voltage to a higher voltage level
SBS	<u>S</u> tatic <u>B</u> ypass <u>S</u> witch
Appliance protection	Term from overvoltage technology Classic mains overvoltage protection consists of lighting surge arrester (class B), overvoltage protection (class C) and, finally, the so-called appliance protection (class D) - see also the http://www.phoenixcontact.com website (topic "TRABTECH")
IGBT	<u>I</u> nsulated <u>G</u> ate <u>B</u> ipolar <u>T</u> ransistor The latest design of high-performance transistors with minimum control power requirement (MOSFET structure) and minimum losses on the output side (structure of a bipolar transistor)
Class D	See appliance protection
LED	<u>L</u> ight <u>E</u> mitting <u>D</u> iode Electronic semi-conductor component, commonly referred to as an LED, used for optic signalling.
PFC	<u>P</u> ower <u>F</u> actor <u>C</u> orrection Circuit technology for minimising system disturbances (particularly important when connecting non-linear loads)
PWM	<u>P</u> ulse <u>W</u> idth <u>M</u> odulation Here: circuit technology for generating a sinusoidal voltage of the highest quality from an existing DC voltage
SNMP	<u>S</u> imple <u>N</u> etwork <u>M</u> anagement <u>P</u> rotocol A protocol encountered frequently in networks for managing / handling components
VFD	<u>O</u> utput <u>V</u> oltage and <u>F</u> requency <u>D</u> ependent from mains supply. The UPS output is dependent on mains voltage and frequency fluctuations. Earlier designation: OFFLINE
VI	<u>O</u> utput <u>V</u> oltage <u>I</u> ndependent from mains supply The UPS output is dependent on mains frequency fluctuations, but the mains voltage is prepared by electronic / passive voltage control units. Earlier designation: LINE-INTERACTIVE
VFI	<u>O</u> utput <u>V</u> oltage and <u>F</u> requency <u>I</u> ndependent from mains supply. The UPS output is independent of mains voltage and frequency fluctuations. Earlier designation: ONLINE

Notes

Notes

Notes

Notes

Guarantee Certificate

Type:

Unit number:

Date of purchase:.....

Dealer stamp / signature

Errors and changes excepted.

AEG

Power Solutions

AEG Power Solutions GmbH

Emil-Siepmann-Straße 32

59581 Warstein-Belecke

Germany

Operating instructions

BAL 8000015763_02 EN