



## Users Operating Instructions

Before operating this cooker,  
please read these instructions carefully



**DTC 90 G**  
**Twin cavity**  
**Gas Cooker**

# Introduction

Congratulations on your purchase of this **Delonghi Gas cooker** which has been carefully designed and produced to give you many years of satisfactory use.

Before using this appliance it is essential that the following instructions are carefully read and fully understood.

We would emphasise that the installation section must be fully complied with for your safety to ensure that you obtain the maximum benefits from your appliance.

## IMPORTANT INSTRUCTIONS AND ADVICE FOR THE USE OF ELECTRICAL APPLIANCES

The use of any electrical appliance requires the compliance with some basic rules, namely:

- do not touch the appliance with wet or damp hands (or feet)
- do not use the appliance whilst in bare feet
- do not allow the appliance to be operated by children or unqualified persons without supervision.

The manufacturer cannot be deemed responsible for damages caused by wrong or incorrect use.

### **Important:**

This appliance is designed and manufactured solely for the cooking of domestic (household) food and is not suitable for any non domestic application and therefore should not be used in a commercial environment.

The appliance guarantee will be void if the appliance is used within a non domestic environment i.e. a semi commercial, commercial or communal environment.

### **Declaration of CE conformity**

- ✓ This cooker has been designed, constructed and marketed in compliance with:
  - Safety requirements of EU Directive "Gas" 90/396/EEC;
  - Safety requirements of EU Directive "Low Voltage" 2006/95/EC;
  - Protection requirements of EU Directive "EMC" 89/336/EEC;
  - Requirements of EU Directive 93/68/EEC.



## IMPORTANT SAFEGUARDS AND RECOMMENDATIONS

After having unpacked the appliance, check to ensure that it is not damaged.

In case of doubt, do not use it and consult your supplier or a professionally qualified technician.

Packing elements (i.e. plastic bags, polystyrene foam, nails, packing straps, etc.) should not be left around within easy reach of children, as these may cause serious injuries.

- **ATTENTION: please peel plastic cover off both sides and front of the cooker before use.**
- Do not attempt to modify the technical characteristics of the appliance as this may cause danger to users.
- Do not carry out any cleaning or maintenance operations on the appliance without first disconnecting it from the electric power supply.
- If you should decide not to use this appliance any longer (or decide to substitute an older model), before disposing of it, it is recommended that it is made inoperative in an appropriate manner in accordance to health and environmental protection regulations, ensuring in particular that all potentially hazardous parts be made harmless, especially in relation to children who could play with unused appliances.
- After use, always ensure that the control knobs are in the off position.
- The appliance is not intended for use by young children or infirm persons unless they have been adequately supervised by a responsible person to ensure that they can use the appliance safely.
- During and after use of the cooker, certain parts will become very hot. Do not touch hot parts.
- Young children should be supervised to ensure that they do not play with the appliance.
- Some appliances are supplied with a protective film on steel and aluminium parts. This film must be removed before using the appliance.

### ■ **WARNING**

When correctly installed, your product meets all safety requirements laid down for this type of product category. However special care should be taken around the rear or the underneath of the appliance as these areas are not designed or intended to be touched and may contain sharp or rough edges, that may cause injury.

- **Fire risk!** Do not store flammable material in the ovens.
- Make sure that electrical cords connecting other appliances in the proximity of the cooker cannot come into contact with the hob or become entrapped in the oven door.
- Do not line the oven walls with aluminium foil. Do not place baking trays or the drip tray on the base of the oven chamber.
- The manufacturer declines all liability for injury to persons or damage to property caused by incorrect or improper use of the appliance.

- The various components of the appliance are recyclable. Dispose of them in accordance with the regulations in force in your country. If the appliance is to be scrapped, remove the power cord.
- Always use oven gloves when removing the shelves and food trays from the oven whilst hot.
- Do not hang towels, dishcloths or other items on the cooker or its handle – as this could be a fire hazard.
- Clean the oven regularly and do not allow fat or oils to build up in the oven base or trays. Remove spillages as soon as they occur.
- Do not stand on the cooker or on the open oven door.
- Always stand back from the cooker when opening the oven door to allow steam and hot air to escape before removing the food.
- This appliance is for domestic use only.
- **WARNING: Taking care NOT to lift the cooker by the door handles.**
- **Safe food handling:** leave food in the oven for as short a time as possible before and after cooking. This is to avoid contamination by organisms which may cause food poisoning. Take particular care during warmer weather.

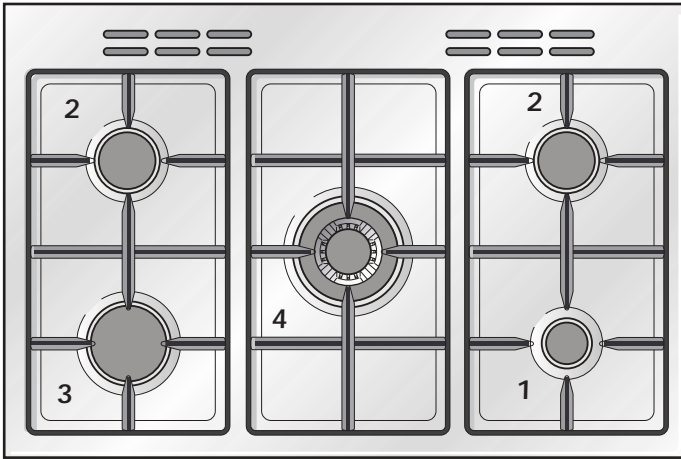

Fig. 1.1

## COOKING HOB

1. Auxiliary burner (A)	1,00 kW
2. Semi-rapid burner (SR)	1,75 kW
3. Rapid burner (R)	3,00 kW
4. Triple-ring burner (TR)	3,50 kW

### Important Note:

The electric ignition is incorporated in the knobs.

Fig. 2.1

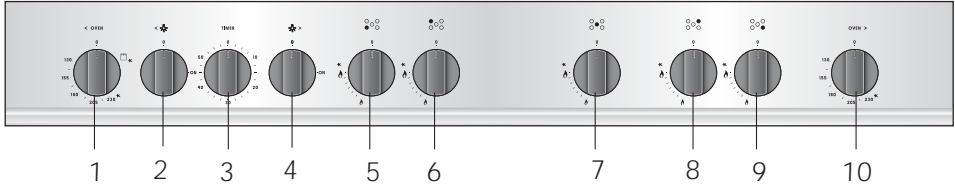

## CONTROL PANEL - Controls description

1. Left gas oven/gas grill control knob
2. Left oven light control knob
3. Minute counter
4. Right oven light control knob
5. Front left burner control knob
6. Rear left burner control knob
7. Central burner control knob
8. Rear right burner control knob
9. Front right burner control knob
10. Right gas oven control knob

## MINUTE COUNTER

The minute counter is a timed acoustic warning device which can be set for a maximum of 60 minutes.

The knob (Fig. 3.1) must be rotated clockwise as far as the 60 minute position and then set to the required time by rotating it anticlockwise.

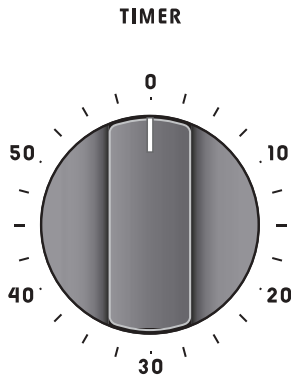

Fig. 3.1



# 4

## How to use the hob burners

### HOB BURNERS

Each hob burner is controlled by a separate gas tap operated by a control knob (fig. 4.1) which has 3 positions marked on the control panel, these are:

– Symbol **0** : tap closed (burner off)

– Symbol  : High (maximum)

– Symbol  : Low (minimum)

Push in and turn the knob anti-clockwise to the selected position.

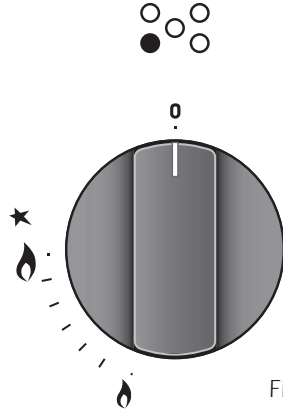

Fig. 4.1



To turn the burner off, fully rotate the knob clockwise to the off position: **0**.

The maximum setting of the control tap is for boiling, the minimum setting is for slow cooking and simmering.

All working positions must be chosen between the maximum and minimum setting, never between the maximum setting and the **"OFF"** position.

### Electric ignition

The sparks generated by the electrodes close to the burners will ignite the chosen burner. Whenever the lighting of the burners is difficult due to peculiar conditions of the gas features or supply, it is advised to repeat the ignition with the knob on "minimum" position.

### LIGHTING THE BURNERS

To ignite the burner, the following instructions are to be followed:

- 1) Lightly press and turn the knob anti-clockwise, and position the knob indicator to the symbol  printed on the control panel (fig. 4.1).
- 2) Press the knob to operate the electric ignition; or, in the case of a mains failure light the burner with a match or lighted taper.
- 3) Adjust the burner according to the setting required.

## CHOICE OF THE BURNER

On the control panel, near each knob, there is a diagram that indicates which burner is controlled by that knob.

Select the burner that is most suitable for the diameter and capacity of the pan to be used.

As an indication, the burners and the pans must be used in the following way:

BURNERS	POT DIAMETER
Auxiliary	12 - 14 cm
Semi-rapid	16 - 24 cm
Rapid	24 - 26 cm
Triple-ring	26 - 28 cm

**do not use pans with concave or convex bases**

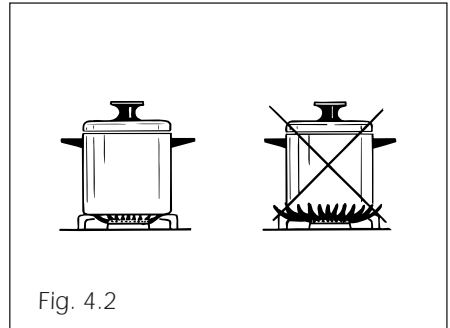

Fig. 4.2

It is important that the base diameter of the pot is at least the same diameter as the burner ring to obtain an efficient heat transfer.

Always position pans centrally over the burners.

**Adjust the size of the flame so that it does not lick up the side of the pan.**  
**Position pan handles so that they cannot be accidentally knocked.**

**Attention: the oven door becomes very hot during operation. Keep children away.**

## GENERAL FEATURES

It is advisable, upon first use, to turn the oven on to the maximum temperature (position **230★**) to eliminate possible traces of grease from the oven burner.

The same operation should be followed for the grill burner.

The gas oven is provided with two burners:

- Oven burner, mounted on the lower part of the oven (wattage: 3,70 kW)
- Grill burner, mounted on the upper part of the oven (wattage: 2,50 kW).

## OVEN BURNER

This burner carries out the normal "oven cooking". The gas flow to the burner is regulated by a thermostat which maintains the oven at a constant temperature.

The temperature of the oven is controlled by a thermostatic probe positioned inside the oven.

The probe must always be kept in its housing, in a clean condition, as an incorrect position or encrustment may cause an alteration in the control of the temperature.

### WARNING:

**The door is hot, use the handle.**

**During use the appliance becomes hot.**

## OVEN THERMOSTAT

The temperature knob is numbered from **130** to **230★** (fig. 5.1) indicating the increasing oven temperature value (see table 5.2).

The thermostat which regulates the flow of gas to the oven burner has a safety valve which automatically shuts off the gas supply when the flame goes out.

The temperature is kept constant on the regulated value.

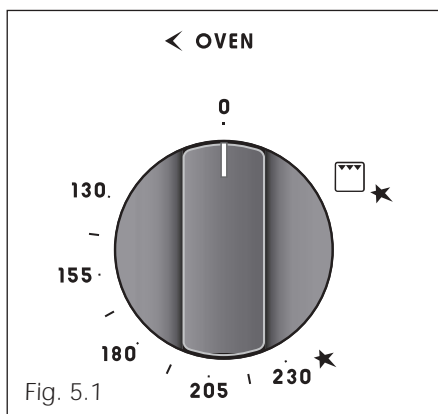

Table 5.2

TEMPERATURE CHART	
Gas Mark	Oven temperature
130	130 °C
-	140 °C
155	155 °C
-	165 °C
180	180 °C
-	190 °C
205	205 °C
-	215 °C
230★	230 °C

## IGNITION OF THE OVEN BURNER

- 1) Open the oven door to the full extent.

**WARNING: Risk of explosion!**  
The oven door must be open during this operation.

- 2) Lightly press and turn the temperature knob anti-clockwise (fig. 5.3) to the max position (230 ★ fig. 5.1).
- 3) Press the knob firmly until the burner lights.

**Never continue this operation for more than 15 seconds. If the burner has still not ignited, wait for about 1 minute prior to repeating the ignition.**

In case of mains failure, press the knob firmly and immediately put a lit match or taper to the opening "F" (fig. 5.4).

- 4) Wait about 10/15 seconds after the burner lights before releasing the knob (time to prime the valve).
- 5) Close the oven door slowly and adjust the burner according to the power required.

If the flame extinguishes for any reason, the safety valve will automatically shut off the gas supply to the burner.

To re-light the burner, first turn the oven control knob to position **O**, wait for at least 1 minute and then repeat the lighting procedure.

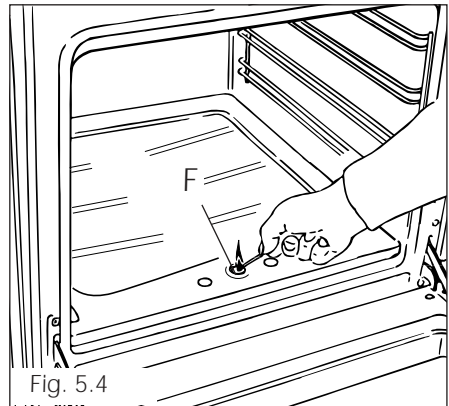
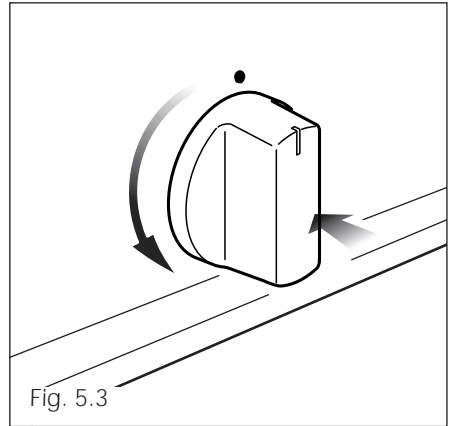

## OVEN COOKING

**For efficient oven preheating, we recommend that grill trays and racks are removed from the oven and replaced after about 15 minutes.**

Before introducing the food, preheat the oven to the desired temperature.

For a correct preheating operation, it is advisable to remove the tray from the oven and introduce it together with the food, when the oven has reached the desired temperature.

Check the cooking time and turn off the oven 5 minutes before the theoretical time to recuperate the stored heat.

## OVEN LIGHT

The cooker is equipped with a light that illuminates the oven to enable visually controlling the food that is cooking. This light is controlled by a switch knob (Fig. 5.5).

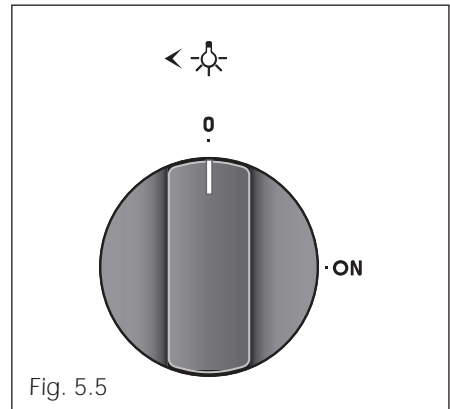

## IGNITION OF THE GRILL

**IMPORTANT:** the grill must always be used with the oven door ajar and with shield "A" mounted (fig. 5.8).

Do not grill with the oven door closed.

**Attention:** the oven door becomes very hot during operation.

Keep children away.

**WARNING.** The heat shield and the oven door reach a very high temperature whilst in use.

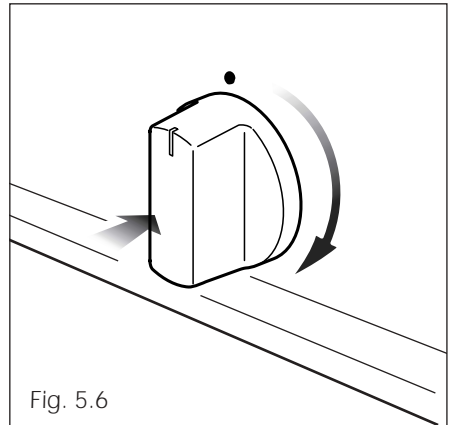



Fig. 5.6

## BURNER

- 1) Open the oven door to the full extent.

**WARNING: Risk of explosion!**  
The oven door must be open during this operation.

- 2) Lightly press and turn the temperature knob clockwise (fig. 5.6) to the  position (fig. 5.1).

- 3) Press the knob firmly until the burner lights.

**Never continue this operation for more than 15 seconds. If the burner has still not ignited, wait for about 1 minute prior to repeating the ignition.**

In case of mains failure, press the knob firmly and put a lit match or taper to the pipe of the burner (fig. 5.7).

- 4) After lighting the burner, wait a few seconds before releasing the knob (until the safety valve stays open).

Do not close the oven door completely. The grill must always be used with the oven door slightly open and with shield "A" mounted (Fig. 5.8).

See specific instructions in the section '**USE OF THE GRILL**'.

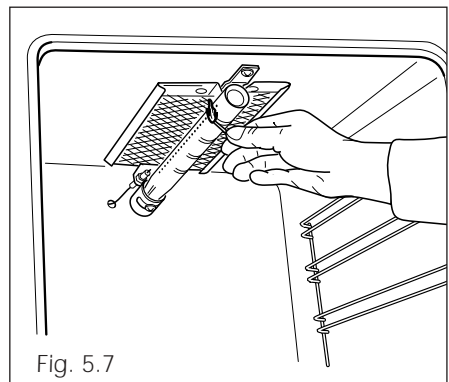

Fig. 5.7

If the flame extinguishes for any reason, the safety valve will automatically shut off the gas supply to the burner.

To re-light the burner, first turn the oven control knob to position **0**, **wait for at least 1 minute and then repeat the lighting procedure.**

## USE OF THE GRILL

**Very important: the grill must always be used with the oven door slightly open and with shield "A" mounted (Fig. 5.8).**

Mount shield "A" which serves to protect the control panel from the heat.

Turn on the grill, as explained in the preceding paragraphs and let the oven preheat for about 5 minutes with the door ajar.

Introduce the food to be cooked, positioning the rack as close to the grill as possible. The drip tray should be placed under the rack to catch the cooking juices and fats.

**Note: It is recommended that you do not grill for longer than 30 minutes at any one time (Grilling for longer than the recommended time may mean the appliance overheats).**

**Attention: the oven door becomes very hot during operation. Keep children away.**

### Notes:

- The grill burner has only one setting, that is full-on.
- It is important that the heat shield is fitted the correct way up, as shown in the figure 5.8.

### IMPORTANT WARNING

For best results when using the grill, place the shelf on the second level and when using the grill pan handle avoid contact with the heat shield which will be **HOT** during use.

**WARNING:**  
Hot part allow to cool  
before removing

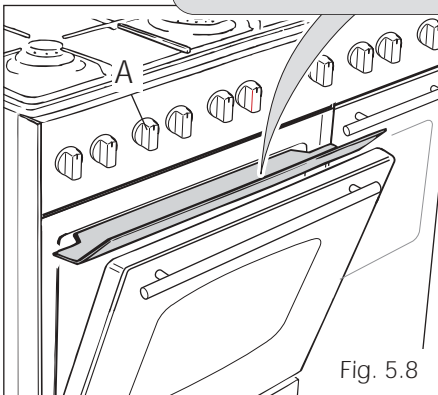

**Attention: the oven door becomes very hot during operation. Keep children away.**

## GENERAL FEATURES

It is advisable, upon first use, to turn the oven on to the maximum temperature (position **230★**) to eliminate possible traces of grease from the oven burner.

The gas oven is provided with one burner:

- Oven burner, mounted on the lower part of the oven (wattage: 2,20 kW)

## OVEN BURNER

This burner carries out the normal "oven cooking". The gas flow to the burner is regulated by a thermostat which maintains the oven at a constant temperature.

The temperature of the oven is controlled by a thermostatic probe positioned inside the oven.

The probe must always be kept in its housing, in a clean condition, as an incorrect position or encrustment may cause an alteration in the control of the temperature.

### WARNING:

**The door is hot, use the handle.**

**During use the appliance becomes hot.**

## TEMPERATURE CONTROL

The temperature knob is numbered from **130** to **230★** (fig. 6.1) indicating the increasing oven temperature value (see table 6.2).

The thermostat which regulates the flow of gas to the oven burner has a safety valve which automatically shuts off the gas supply when the flame goes out.

The temperature is kept constant on the regulated value.

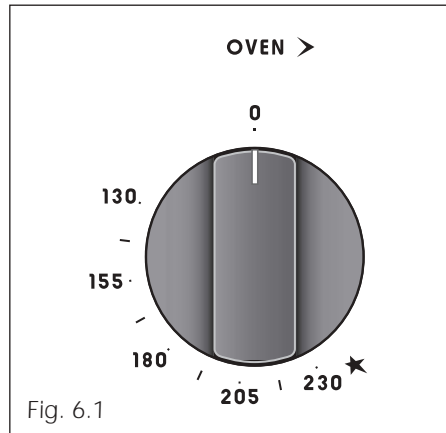

Table 6.2

TEMPERATURE CHART	
Gas Mark	Oven temperature
130	130 °C
-	140 °C
155	155 °C
-	165 °C
180	180 °C
-	190 °C
205	205 °C
-	215 °C
230★	230 °C



## IGNITION OF THE OVEN BURNER

- 1) Open the oven door to the full extent.

**WARNING: Risk of explosion! The oven door must be open during this operation.**

- 2) Lightly press and turn the temperature knob anti-clockwise (fig. 6.3) to the max position (230★ fig. 6.1).
- 3) Press the knob firmly until the burner lights.

**Never continue this operation for more than 15 seconds. If the burner has still not ignited, wait for about 1 minute prior to repeating the ignition.**

In case of mains failure, press the knob firmly and immediately put a lit match or taper to the opening "F" (fig. 6.4).

- 4) Wait about 10/15 seconds after the burner lights before releasing the knob (time of priming of the valve).
- 5) Close the oven door slowly and adjust the burner according to the power required.

If the flame extinguishes for any reason, the safety valve will automatically shut off the gas supply to the burner.

To re-light the burner, first turn the oven control knob to position **0**, wait for at least **1 minute** and then repeat the lighting procedure.

## OVEN COOKING

**For efficient oven preheating, we recommend that grill trays and racks are removed from the oven and replaced after about 15 minutes.**

Before introducing the food, preheat the oven to the desired temperature.

For a correct preheating operation, it is advisable to remove the tray from the oven and introduce it together with the food, when the oven has reached the desired temperature.

Check the cooking time and turn off the oven 5 minutes before the theoretical time to recuperate the stored heat.

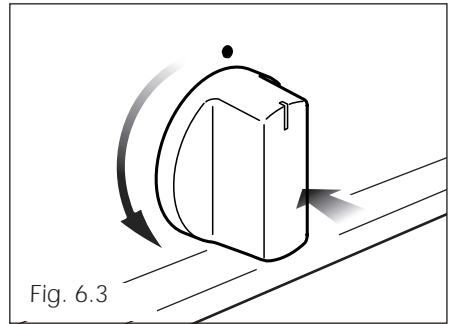

Fig. 6.3

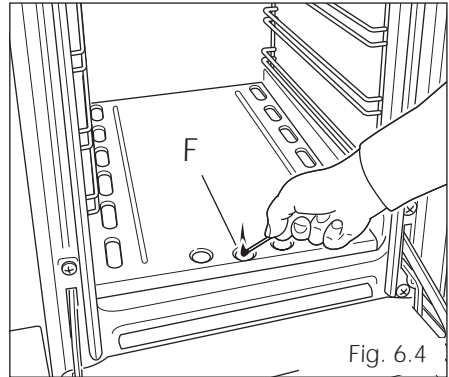

Fig. 6.4

## OVEN LIGHT

The cooker is equipped with a light that illuminates the oven to enable visually controlling the food that is cooking.

This light is controlled by a switch knob (Fig. 6.5).

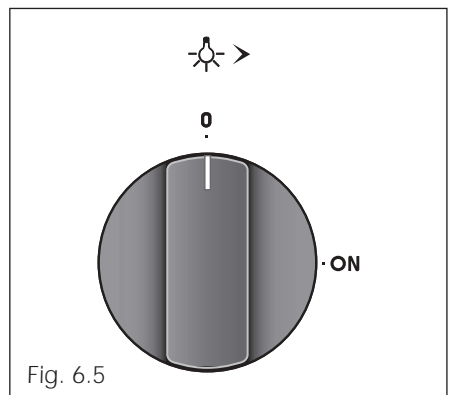

Fig. 6.5

Temperature and times given are approximate, as they will vary depending on the quality and amount of food being cooked.

Remember to use ovenproof dishes and to adjust the oven temperature during cooking if necessary.

<b>APPROX. TEMPERATURE</b>	<b>HEAT OF</b>	<b>TYPE OF DISH TO COOK OVEN</b>
125°C (257°F)	Very cool oven	Meringue, slow cooking foods.
135°C - 140°C (275°F - 285°F)	Cool or slow oven	Milk puddings, very rich fruit cakes, eg., Christmas.
150°C (300°F)	Cool or slow oven	Stews, casseroles, braising, rich fruit cakes, eg., Dundee.
160°C - 170°C (320°F - 338°F)	Warm oven	Biscuits, Low temperature roasting, rich plain cakes eg., Madeira cake.
180°C (356°F)	Moderate oven	Plain cakes, eg., Victoria sandwich, meat pies.
190°C (374°F)	Fairly hot oven	Small cakes, savoury flans, fish.
200°C (392°F)	Hot oven	Plain cakes and buns, swiss rolls, fruit pies. High temp. roasting.
215°C (419°F)	Moderately hot oven	Bread and bread rolls etc., scones, flaky and rough puff pastry, Yorkshire pudding.
225°C (437°F)	Very hot oven	Sausage rolls, mince pies, puff pastry. Browning ready cooked dishes.

## Important notes

Installation, and any demonstration, information or adjustments are not included in the warranty.

The cooker must be installed by a qualified person in accordance with the relevant Standards.

In the UK C.O.R.G.I registered installers are authorised to undertake the installation and service work in compliance with the above regulations. All Comet authorised installers are C.O.R.G.I. registered.

### **Attention**

**The appliance gets very hot, mainly around the cooking areas. It is very important that children are not left alone in the kitchen when you are cooking.**

### **AFTER SALES SERVICE**

Should you require to book a service call telephone 0870 5425425.  
For product information and advise telephone 0113 2793520

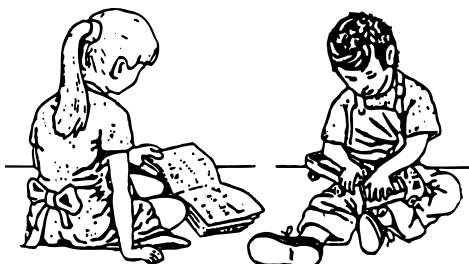

## Do's and do not's

- Do not grill **with oven door closed**. Always fit the heat shield supplied with the cooker under the front panel before commencing operations.
- Do read the user instructions carefully before using the cooker for first time.
- Do allow the oven to heat for one and a half hours, before using for the first time, in order to expel any smell from the new oven insulation, without the introduction of food.
- Do clean your oven regularly.
- Do remove spills as soon as they occur.
- Do always use oven gloves when removing food shelves and trays from the ovens.
- Do not allow children near the cooker when in use.
- Do not allow fat or oils to build up in the ovens trays, or oven base.
- Do not place cooking utensils or plates directly onto the oven base.
- Do not grill food containing fat without using the grid.
- Do not cover the grilling grid with aluminium-foil.
- Do not use the oven tray for roasting.
- Do not place hot enamel parts in water. Leave them to cool first.
- Do not allow vinegar, coffee, milk, saltwater, lemon or tomato juice to remain in contact with enamel parts (inside the oven and on the oven tray).
- Do not use abrasive cleaners or powders that will scratch the surface of the stainless steel and the enamel.
- Do not attempt to repair the internal workings of your cooker.
- Do remove the protective film before the first use.
- **Fire risk!** Do not store flammable material in the ovens and in the storage compartment.

### FOR YOUR SAFETY

The product should only be used for its intended purpose which is for the cooking of domestic foodstuffs.

Under no circumstances should any external covers be removed for servicing or maintenance except by suitably qualified personnel.

## GENERAL ADVICE

---

- When the appliance is not being used, it is advisable to keep the gas tap closed.
- Every now and then check to make sure that the flexible tube that connects the gas line or the gas cylinder to the appliance is in perfect condition and get it replaced if it shows any signs of wearing or damage.
- The periodical lubrication of the gas taps must be done only by specialised personnel.
- If a tap becomes stiff, do not force; contact your local Service Centre.
- **Important:**  
**the use of suitable protective clothing/gloves is recommended when handling or cleaning of this appliance.**

## WARNING

When correctly installed, your product meets all safety requirements laid down for this type of product category. However special care should be taken around the rear or the underneath of the appliance as these areas are not designed or intended to be touched and may contain sharp or rough edges, that may cause injury.

### **IMPORTANT:**

**Before cleaning or carrying out any maintenance disconnect the appliance from the electrical supply and wait for it to cool down.**

### **Attention**

**The appliance gets very hot, mainly around the cooking areas. It is very important that children are not left alone in the kitchen when you are cooking.**

**Do not use a steam cleaner because the moisture can get into the appliance thus make it unsafe.**

## ENAMELLED PARTS

All the enamelled parts must be cleaned with a sponge and soapy water or other non-abrasive products.

Dry preferably with a microfibre or soft cloth.

Acidic substances like lemon juice, tomato sauce, vinegar etc. can damage the enamel if left in contact for too long.

## STAINLESS STEEL, ALUMINIUM PARTS AND SILK-SCREEN PRINTED SURFACES

Clean using an appropriate product. Always dry thoroughly.

**IMPORTANT:** these parts must be cleaned very carefully to avoid scratching and abrasion. You are advised to use a soft cloth and neutral soap.

**CAUTION:** Do not use abrasive substances or non-neutral detergents as these will irreparably damage the surface.

## GAS TAPS

In the event of operating faults in the gas taps, call the After Sales Service Department.

## FLEXIBLE TUBE

From time to time, check the flexible tube connecting the gas supply to the cooker. It must be always in perfect condition; in case of damage arrange for it to be replaced by a C.O.R.G.I. registered installer.

## REPLACING THE OVEN LIGHT BULB

**Switch the cooker off at the mains.** When the oven is cool, unscrew and replace the bulb with another one resistant to high temperatures (300°C), voltage 230 V (50 Hz), E14 and same power (check watt power as stamped in the bulb itself) of the replaced bulb.

**Note:** Oven bulb replacement is not covered by your guarantee.

## BURNERS

The burners can be removed and washed with soapy water only.

They will remain perfect if always cleaned with products used for silverware.

After cleaning, check that the burner-caps and burner-heads are dry before placing them in the **respective housings**.

### Note:

- **Do not clean burners in a dishwasher.**
- **To avoid damage to the electric ignition do not use it when the burners are not in place.**

## CORRECT REPLACEMENT OF THE BURNERS

It is very important to check that the burner flame distributor **F** and the cap **C** has been correctly positioned (see figs. 8.1 - 8.2) - failure to do so can cause a poor burner flame and/or damage to the burner and hob.

Check that the electrode **"S"** (fig. 8.1) is always clean to ensure trouble-free sparking.

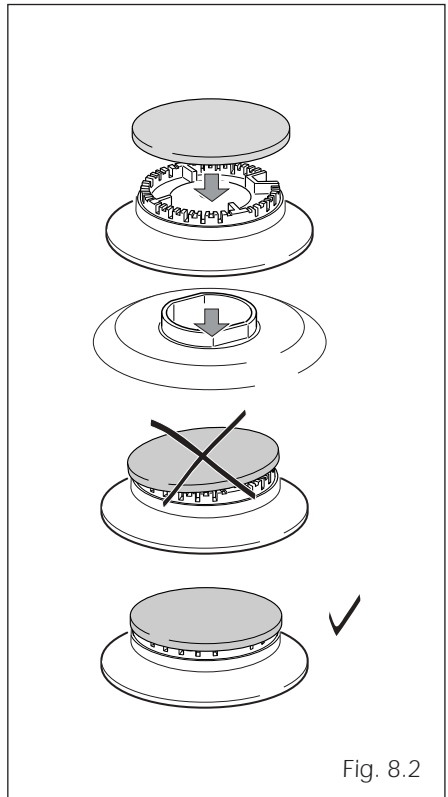
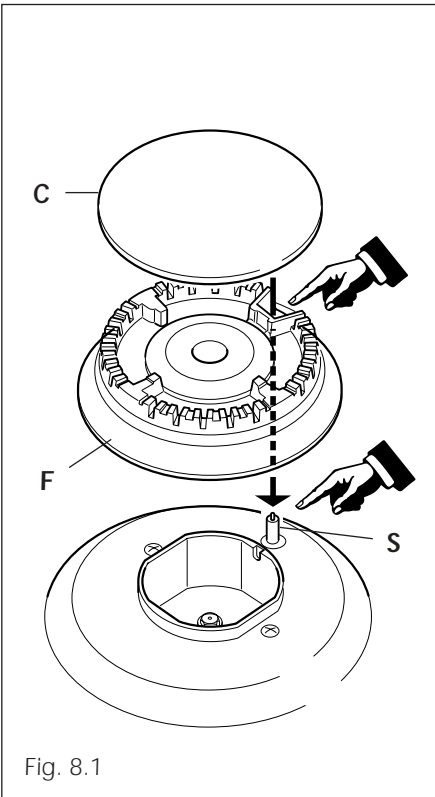

## TRIPLE RING BURNER

The triple ring burner must be correctly positioned (see fig. 8.3); the burner rib must enter in their logement as shown by the arrow.

The burners must be correctly positioned so that they cannot rotate (fig. 8.4).

Then position the cap **A** and the ring **B** (fig. 8.4 - 8.5).

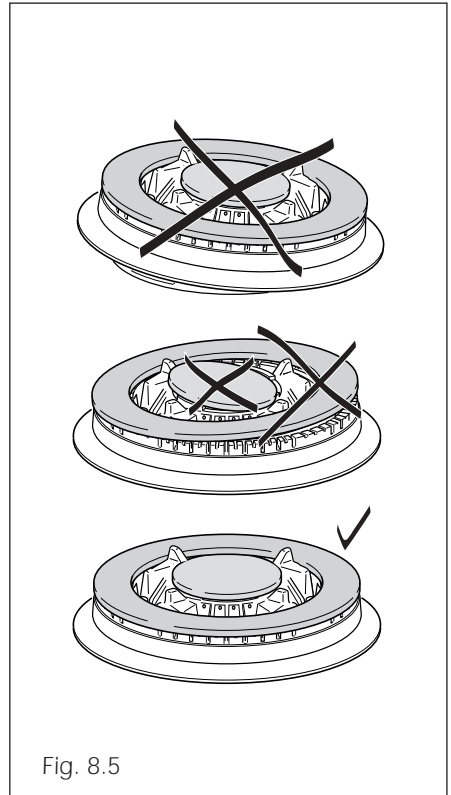
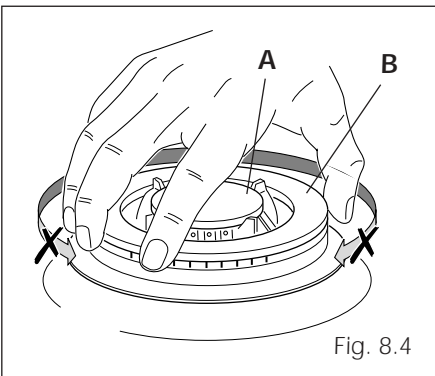
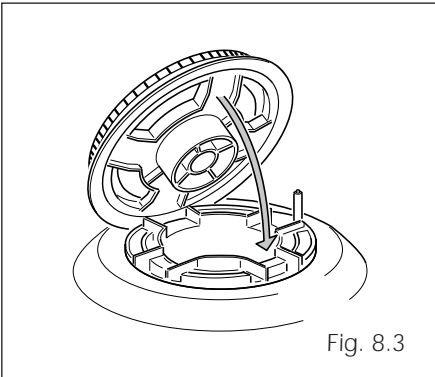



## OVEN DOORS

The internal glass panel can be easily removed for cleaning by unscrewing the 2 retaining screws (Fig. 8.6).

**Do not use harsh abrasive cleaners or sharp metal scrapers to clean the oven door glass since they can scratch the surface, which may result in shattering of the glass.**

## STORAGE COMPARTMENT

The storage compartment is accessible through the pivoting panel (fig. 8.7).

**Do not store flammable material in the ovens or in the storage compartment.**

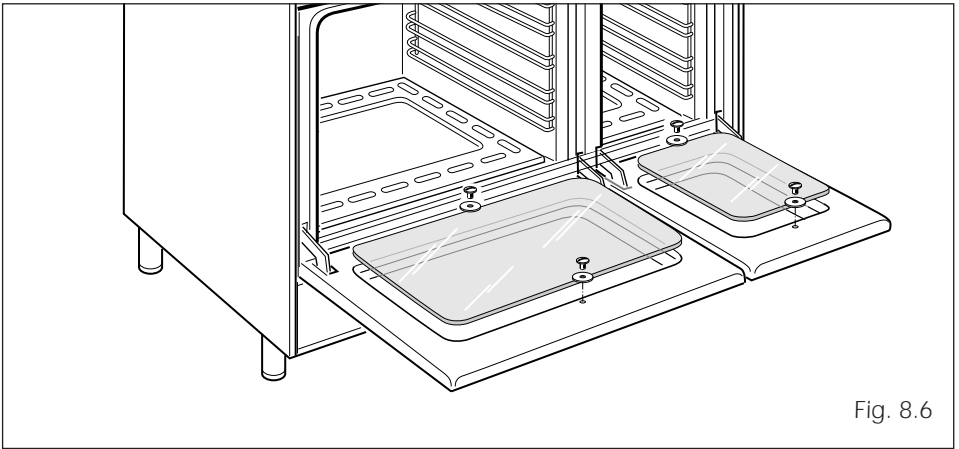

Fig. 8.6

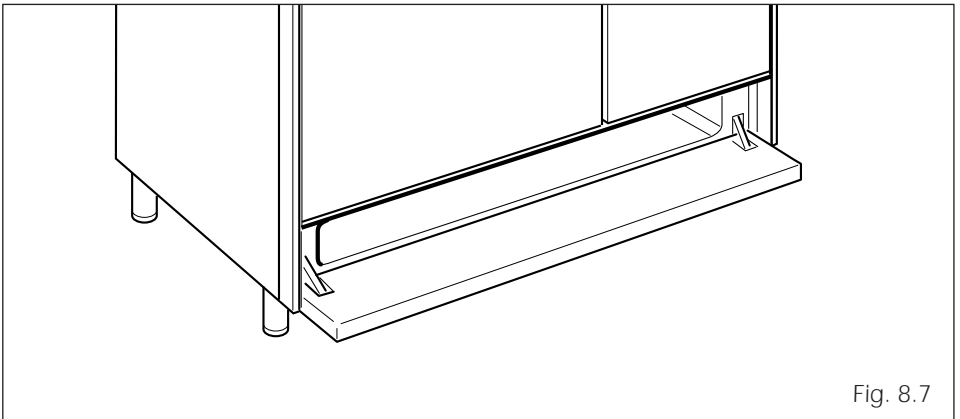

Fig. 8.7

## INSIDE OF OVEN

The oven should always be cleaned after use when it has cooled down.

The cavity should be cleaned using a mild detergent solution and warm water. Suitable proprietary chemical cleaners may be used after first consulting with the manufacturers recommendations and testing a small sample of the oven cavity. Abrasive cleaning agents or scouring pads/cloths should not be used on the cavity surface.

- **NOTE:** The manufacturers of this appliance will accept no responsibility for damage caused by chemical or abrasive cleaning.

**Attention: Do not store flammable material in the oven.**

## ASSEMBLY AND DISMANTLING OF THE SIDE RUNNER FRAMES

- Fit the side runner frames into the holes on the side walls inside the oven (Fig. 8.8).
- Slide the tray and rack into the runners (Fig. 8.9).  
The shelf must be fitted so that the safety catch, which stops it sliding out, faces the inside of the oven.
- To dismantle, operate in reverse order.

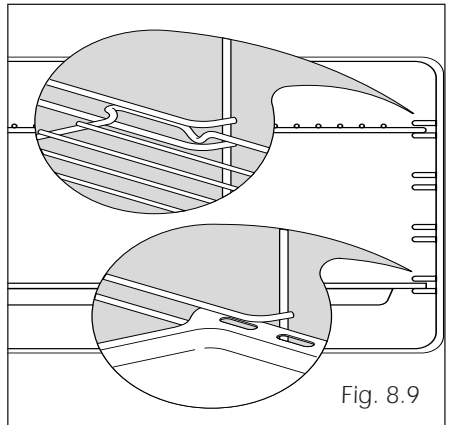
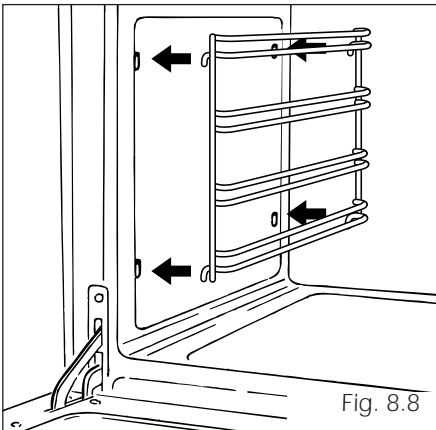

## REMOVING THE OVEN DOORS

The oven door can easily be removed as follows:

- Open the door to the full extent (fig. 8.10A).
- Attach the retaining rings to the hooks on the left and right hinges (fig. 8.10B).
- Hold the door as shown in fig. 8.10.
- Gently close the door and withdraw the lower hinge pins from their location (fig. 8.10C).
- Withdraw the upper hinge pins from their location (fig. 8.10D).
- Rest the door on a soft surface.
- To replace the door, repeat the above steps in reverse order.

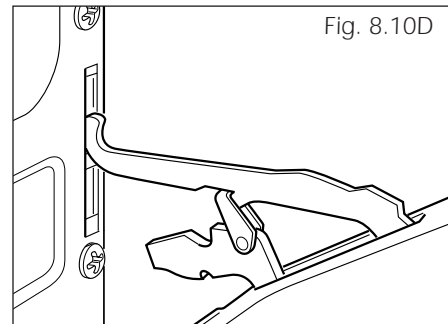
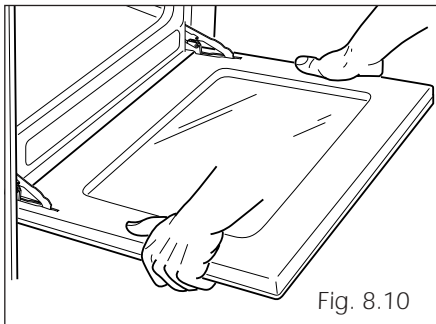
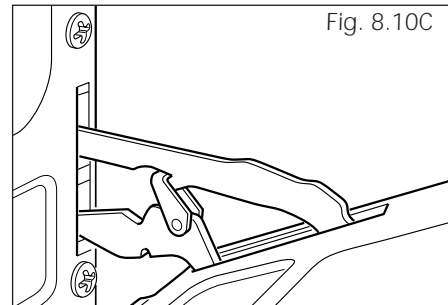
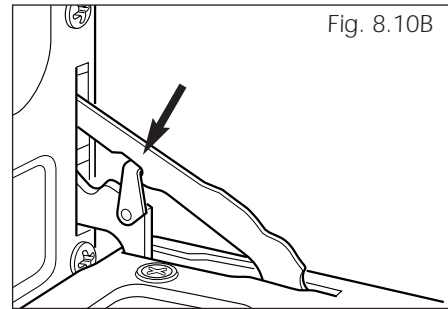
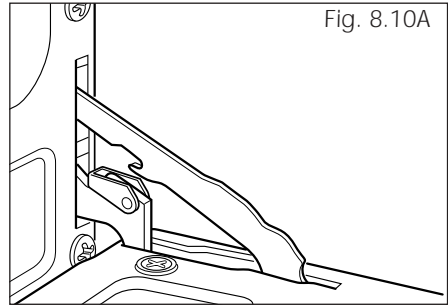

# Advice for the installer

## IMPORTANT

- Cooker installation must only be carried out by **QUALIFIED TECHNICIANS and in compliance with local safety standards**. Failure to observe this rule will invalidate the warranty.
- The appliance must be installed in compliance with regulations in force in your country and in observation of the manufacturer's instructions.
- Always unplug the appliance before carrying out any maintenance operations or repairs.
- Some appliances are supplied with a protective film on steel and aluminium parts.  
**This film must be removed before using the cooker.**
- **Important: the use of suitable protective clothing/gloves is recommended when handling or installing of this appliance.**

**This cooker has class "2/1" overheating protection so that it can be installed next to a cabinet.**

The appliance may be installed in a kitchen, Kitchen/diner or a bed sitting room, but not in a room or space containing a bath or a shower.

The appliance must not be installed in a bed-sitting room of less than 20 m<sup>3</sup>.

The appliance is designed and approved for domestic use only and should not be installed in a commercial, semi commercial or communal environment.

Your product will not be guaranteed if installed in any of the above environments and could affect any third party or public liability insurances you may have.

If the cooker is installed adjacent to furniture which is higher than the gas hob cook-top, a gap of at least 200 mm must be left between the side of the cooker and the furniture.

The furniture walls adjacent to the cooker must be made of material resistant to heat.

The veneered synthetic material and the glue used must be resistant to a temperature of 90°C in order to avoid ungluing or deformations.

Curtains must not be fitted immediately behind appliance or within 500 mm of the sides.

It is essential that the cooker is positioned as stated in Fig. 9.1.

**The cooker must be installed by a qualified technician and in compliance with local safety standards.**

If the cooker is located on a pedestal it is necessary to provide safety measures to prevent falling out.

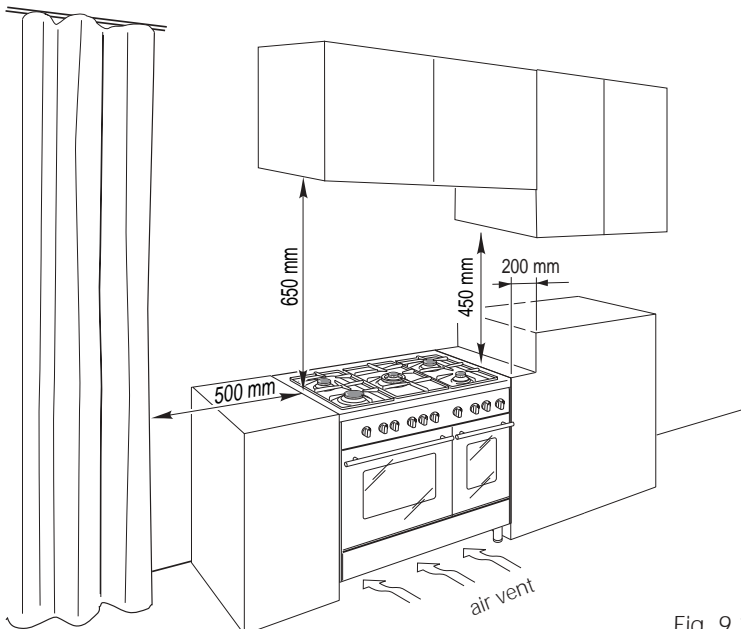

Fig. 9.1

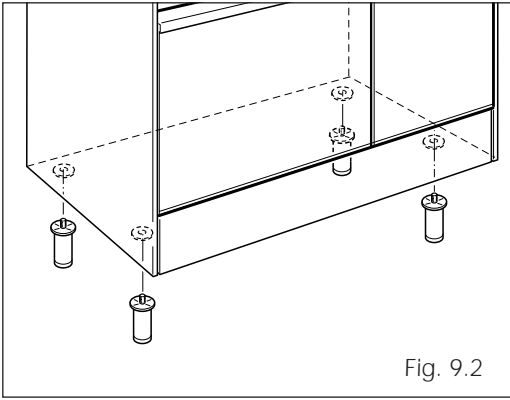

Fig. 9.2

## FITTING THE ADJUSTABLE FEET

The adjustable feet must be fitted to the base of the cooker before use.

Rest the rear of the cooker on a piece of the polystyrene packaging exposing the base for the fitting of the feet.

Fit the 4 legs by screwing them tight into the support base as shown in picture 9.3.

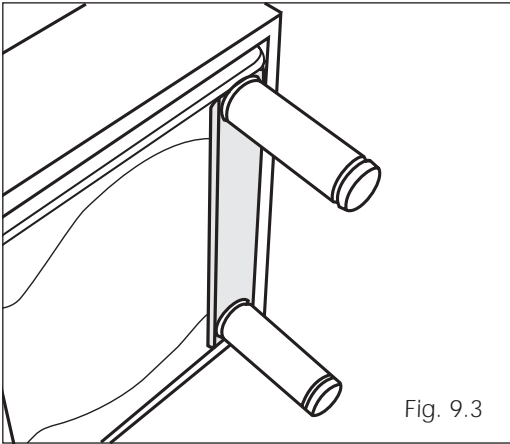

Fig. 9.3

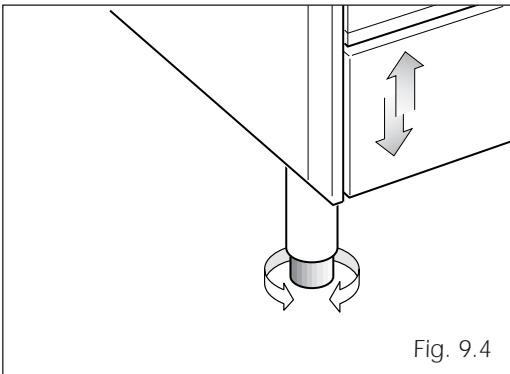

Fig. 9.4

## LEVELLING THE COOKER

The cooker may be levelled by screwing the lower ends of the feet IN or OUT (fig. 9.4).

## MOVING THE COOKER

### WARNING

When raising cooker to upright position always ensure two people carry out this manoeuvre to prevent damage to the adjustable feet (fig. 9.5).

### WARNING

Be careful: do not lift the cooker by the door handle when raising to the upright position (fig. 9.6).

### WARNING

When moving cooker to its final position **DO NOT DRAG** (fig. 9.7). Lift feet clear of floor (fig. 9.5).

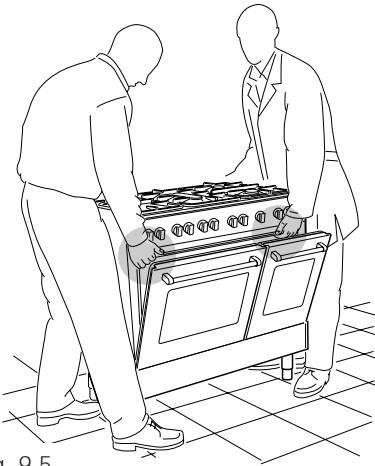

Fig. 9.5

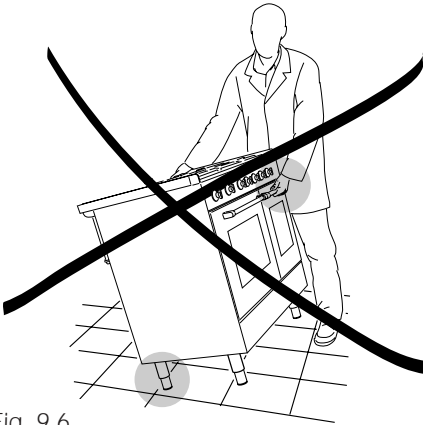

Fig. 9.6

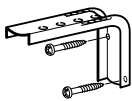
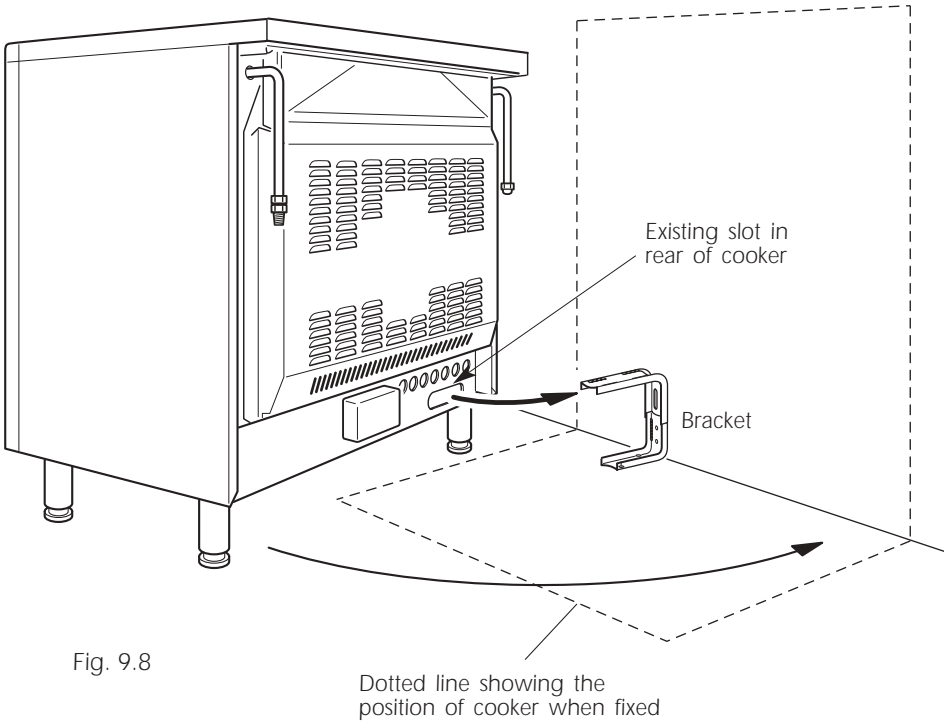

Fig. 9.7

# Stability bracket

We recommend a stability bracket is fitted to the cooker.

The type shown in fig. 9.8 can be purchased from most plumbers merchants and do it yourself (D.I.Y.) shops.



Wall fixing

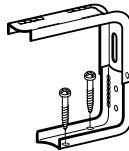

Floor fixing

Outline of cooker backplate at the engagement slot

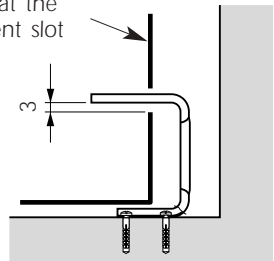

Dimension is in millimetres



## PROVISION FOR VENTILATION

- ✓ The appliance should be installed into a room or space with an air supply in accordance with BS 5440-2: 2000.
- ✓ For rooms with a volume of less than 5 m<sup>3</sup> - permanent ventilation of 100 cm<sup>2</sup> free area will be required.
- ✓ For rooms with a volume of between 5 m<sup>3</sup> and 10 m<sup>3</sup> a permanent ventilation of 50 cm<sup>2</sup> free area will be required unless the room has a door which opens directly to the outside air in which case no permanent ventilation is required.
- ✓ For rooms with a volume greater than 10 m<sup>3</sup> - no permanent ventilation is required.

**NB. Regardless of room size, all rooms containing the appliance must have direct access to the outside air via an openable window or equivalent.**

- ✓ Where there are other fuel burning appliances in the same room, BS 5440-2: 2000 should be consulted to determine the correct amount of free area ventilation requirements.
- ✓ The above requirements allow also for use of a gas oven and grill but if there are other gas burning appliances in the same room, consult a qualified engineer.

**IMPORTANT NOTE**

This appliance is supplied for use on NATURAL GAS or LPG (check the gas regulation label attached on the appliance).

- ✓ Appliances supplied for use on NATURAL GAS: they are adjusted for this gas only and cannot be used on any other gas (LPG) without modification. The appliances are manufactured for conversion to LPG.
- ✓ Appliances supplied for use on LPG: they are adjusted for this gas only and cannot be used on any other gas (NATURAL GAS) without modification. The appliances are manufactured for conversion to NATURAL GAS.

If the NATURAL GAS/LPG conversion kit is not supplied with the appliance this kit can be purchased by contacting the After-Sales Service.

**INSTALLATION & SERVICE REGULATIONS (UNITED KINGDOM)**

It is a legal requirement that all gas appliances are Installed & Serviced by a competent person in accordance with the current editions of the following Standards & Regulations or those regulations appropriate to the geographical region in which they are to be installed:

- ✓ Gas Safety (Installation & Use) Regulations
- ✓ Building Regulations
- ✓ British Standards
- ✓ Regulations for Electrical Installation

Installation and service of any gas product must be made by a suitably qualified person competent on the type of product being installed or serviced and holding a valid certificate of competence for the work being carried out. Currently the proof of competence is the Accredited Certification Scheme (ACS) or S/NVQ that has been aligned to the ACS.

It is also a requirement that all businesses or self employed installers are members of a class of person approved by the Health and Safety Executive. Currently the only body with such approval is CORGI.

Failure to install the appliance correctly could invalidate any manufacturers warranty and lead to prosecution under the above quoted regulation.

# Gas connection

The installation of the gas appliance to Natural Gas or LP Gas must be carried out by a C.O.R.G.I. registered installer. Installers shall take due account of the provisions of the relevant British Standards Code of Practice, the Gas Safety Regulations and the Building Standards (Scotland)(Consolidation) Regulations issued by the Scottish Development Department.

## Installation to Natural Gas

Installation to Natural Gas must conform to the Code of Practice, etc.  
The supply pressure for Natural Gas is 20 mbar.  
The installation must conform to the relevant British Standards.

## Installation to LP Gas

When operating on Butane gas a supply pressure of 28-30 mbar is required. When using Propane gas a supply pressure of 37 mbar is required.  
The installation must conform to the relevant British Standards.

**Warning:** Only a C.O.R.G.I. registered installer, also with technical knowledge of electricity should install the appliance. He should observe the Regulations and Codes of Practice governing such installation of gas appliances.

Note: It is recommended that the gas connection to the appliance is installed with a flexible connecting tube made to BS5386.

### Notes:

- ✓ Flexible hoses can be used where the sited ambient temperature of the hose does not exceed 70°C. These hoses must be manufactured in accordance with BS669 part 1 and be of the correct construction for the type of gas being used.
- ✓ Gas hoses designed for natural gas **MUST NOT** be used for supplying LPG gas (LPG gas hoses can be identified by either a red band or stripe on the rubber outer coating of the hose).  
The hose should not be crushed or trapped or be in contact with sharp or abrasive edges.

Using a suitable leak detection fluid solution (e.g. Rocol) check each gas connection one at a time by brushing the solution over the connection.

The presence of bubbles will indicate a leak.  
If there is a leak, tighten the fitting and then recheck for leaks.

### IMPORTANT!

**Do not use a naked flame to test for leaks.**

**Gas connection** **GB** Cat: II 2H3+

The gas supply must use the nearest gas inlet pipe which is located at the left or the right hand side at the rear of the appliance (figs. 10.1, 10.3).

The hose should also be connected in such away that it does not touch the floor.

To screw the connecting tube operate with two spanners (fig.10.2).

The unused end inlet pipe must be closed with the plug interposing the gasket.

**After connecting to the mains, check that the coupling are correctly sealed, using soapy solution, but never a flame.**

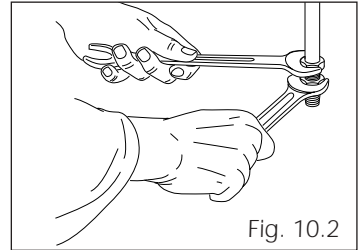

Fig. 10.2

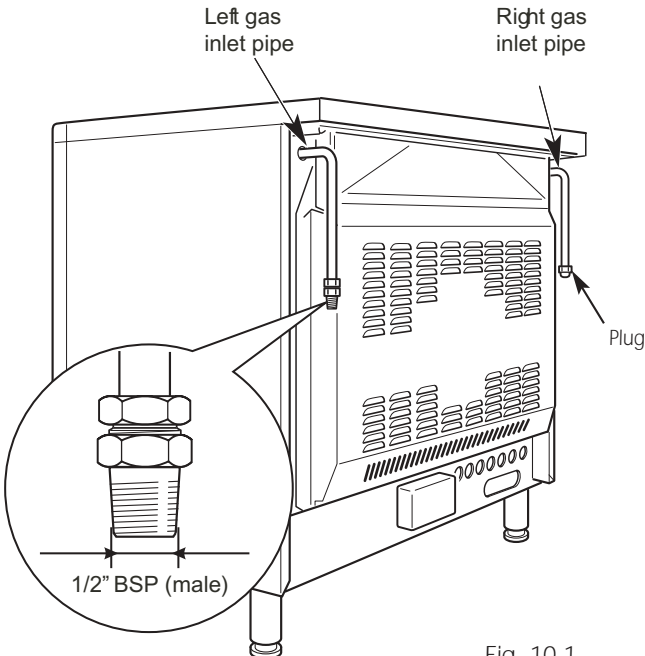

Fig. 10.1

# IMPORTANT PRESCRIPTIONS FOR GAS CONNECTION

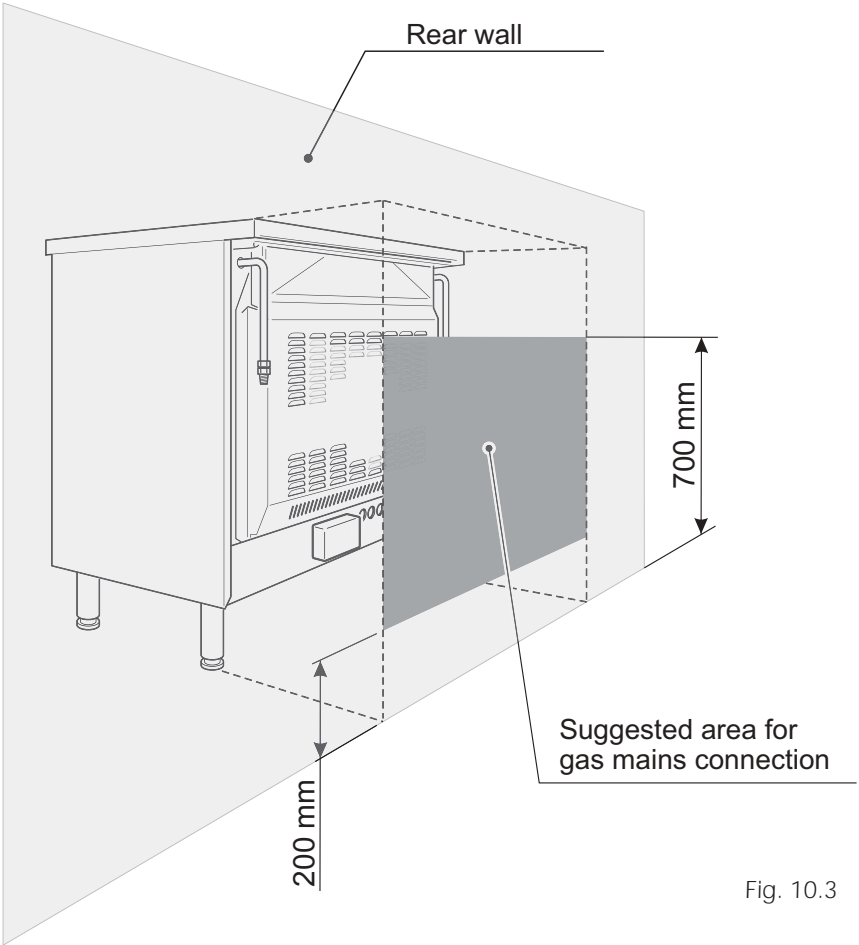

Fig. 10.3

# Conversion to Natural Gas or to LPG

## INJECTORS REPLACEMENT OF THE TOP BURNERS

If the injectors are not supplied they can be obtained from the "Service Centre".

The diameter is marked on the injector in cents of millimetre.

Select the injectors to be replaced according to the "Table for the choice of the injectors" (page 39).

To replace the injectors:

- Remove the gratings, the burner and the covers;
- Using a wrench, substitute the nozzle injectors "J" (Figs. 10.4a - 10.4b) with those most suitable for the kind of gas for which it is to be used.

The burners are conceived in such a way so as not to require the regulation of the primary air.

## ADJUSTING OF THE MINIMUM OF THE TOP BURNERS

In the minimum position the flame must have a length of about 4 mm and must remain lit even with a quick turn from the maximum position to that of minimum.

The flame adjustment is done in the following way:

- Turn on the burner
- Turn the tap to the MINIMUM position
- Take off the knob
- With a small flat screwdriver turn the screw inside the tap rod to the correct regulation (fig. 10.5).

Normally for LPG, tighten up the regulation screw.

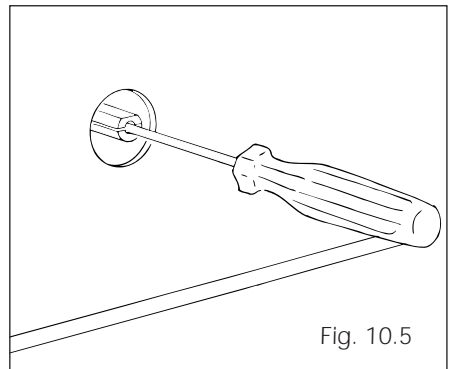
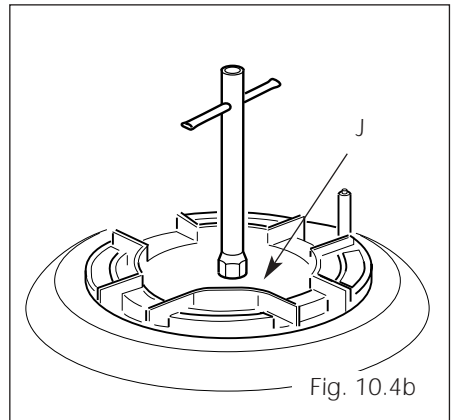
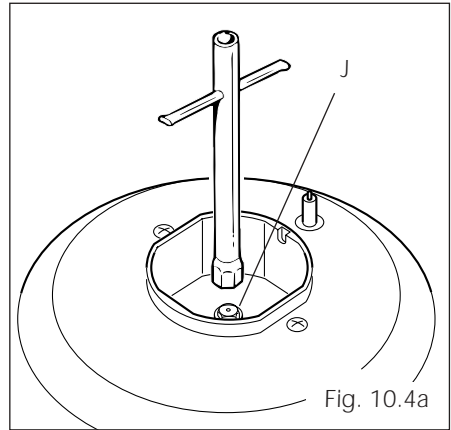



## TABLE FOR THE CHOICE OF THE INJECTORS Cat: II 2H3+

BURNERS	Nominal Power [kW]	Reduced Power [kW]	G 30 - 28-30 mbar G 31 - 37 mbar			G 20 20 mbar		
			By-pass [1/100 mm]	Ø injector [1/100 mm]	Ring opening [mm]	By-pass [1/100 mm]	Ø injector [1/100 mm]	Ring opening [mm]
Auxiliary (A)	1,00	0,30	27	50	-	adjustable	72 (X)	-
Semi-rapid (SR)	1,75	0,45	32	65	-	adjustable	97 (Z)	-
Rapid (R)	3,00	0,75	42	85	-	adjustable	115 (Y)	-
Triple-ring (TR)	3,50	1,50	65	95	-	adjustable	135 (T)	-
Left Oven	3,70	0,75	40	92	fully open*	adjustable	140	5 *
Left Grill	2,50	-	-	80	fully open*	-	120	4 *
Right Oven	2,20	0,63	38	72	fully open*	adjustable	110	4 *

\* = Reference value

INCREASE OF AIR NECESSARY FOR GAS COMBUSTION (2 m <sup>3</sup> /h x kW)	
BURNERS	Air necessary for combustion [m <sup>3</sup> /h]
Auxiliary (A)	2,00
Semi-rapid (SR)	3,50
Rapid (R)	6,00
Triple-ring (TR)	7,00
Left Oven	7,40
Left Grill	5,00
Right Oven	4,40

## LEFT OVEN

### OVEN BURNER AND GRILL BURNER REPLACEMENT OF INJECTORS

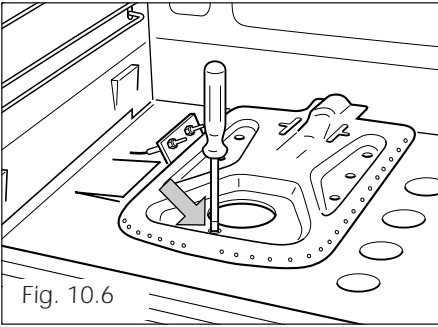

#### a) oven burner

- Lift and remove the lower panel inside the oven.
- Remove the burner securing screw (fig. 10.6).
- Withdraw the burner as shown in figure 10.7 and rest it inside the oven. Take care not to damage the wire to the ignition electrode and the safety valve probe.
- Using a 7 mm box spanner, unscrew the injector (indicated by the arrow in fig. 10.7) and replace it by the proper one according to the kind of gas.  
Then replace the burner repeating the above steps in reverse order.

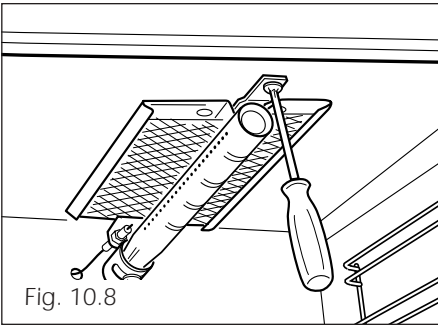
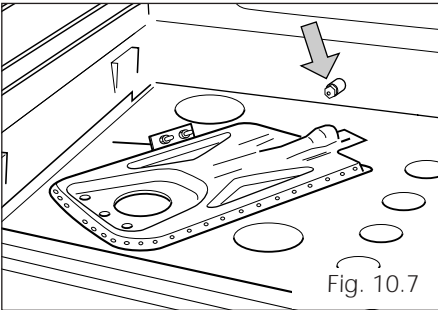

#### b) grill burner

- Remove the burner by unscrewing the front screw (fig. 10.8). Gently suspend the burner as shown in figure 10.9. Be careful not to damage the wire of the electric ignition and the probe of the safety valve.
- Using a 7 mm box spanner, replace the injector (indicated by the arrow in fig. 10.9) by the proper one according to the kind of gas.
- Replace the burner repeating the above steps in reverse order.

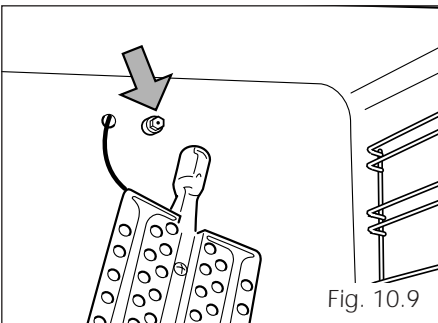



# REGULATION OF AIR SUPPLY TO OVEN AND GRILL BURNERS

Using a cross-head screwdriver, slacken the screw securing the air flow regulation collar (fig. 10.10 and 10.11) and move the collar forward or backward to increase or reduce the air aperture in accordance with gas type and the indications in the "TABLE FOR THE CHOICE OF THE INJECTORS".  
Light the burner and check the flame.

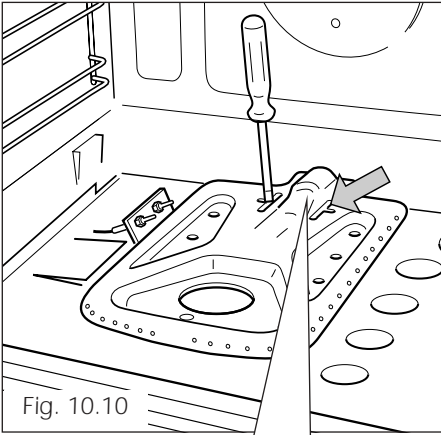

Fig. 10.10

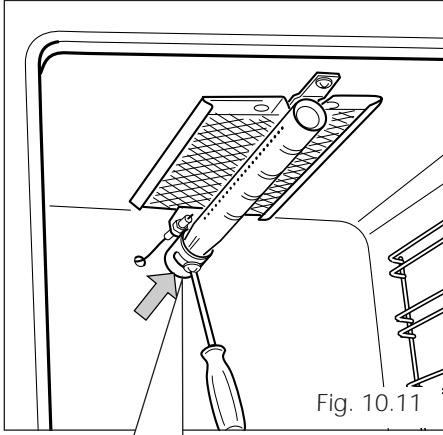
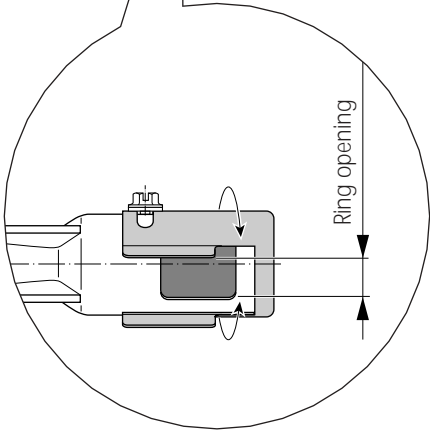
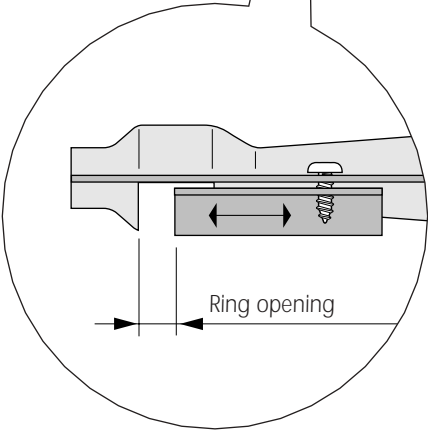

Fig. 10.11



# RIGHT OVEN

## OVEN BURNER REPLACEMENT OF INJECTOR

- Lift and remove the lower panel inside the oven.
- Remove the 2 screws securing the burner (fig. 10.12).
- Withdraw the burner as shown in figure 10.13 and rest it inside the oven. Take care not to damage the wire to the ignition electrode and the safety valve probe.
- Using a 7 mm box spanner, unscrew the injector (indicated by the arrow in fig. 10.13) and replace it by the proper one according to the kind of gas.  
Then replace the burner repeating the above steps in reverse order.

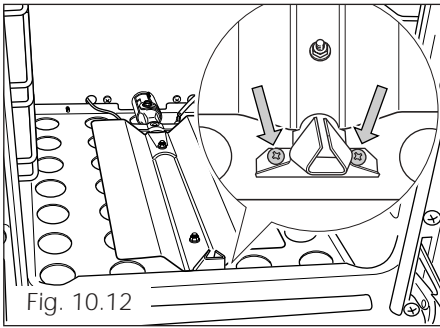

## REGULATION OF AIR SUPPLY TO OVEN BURNER

Using a screwdriver, slacken the screw securing the air flow regulation collar (fig. 10.14) and rotate the collar clockwise or anti-clockwise to increase or reduce the air aperture in accordance with gas type and the indications in the "TABLE FOR THE CHOICE OF THE INJECTORS".  
Light the burner and check the flame.

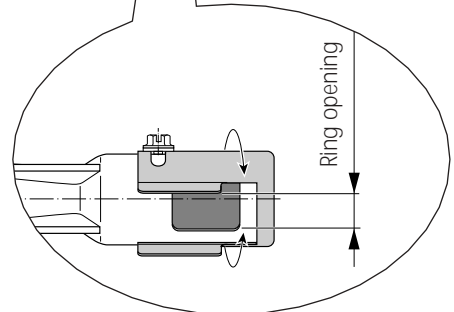
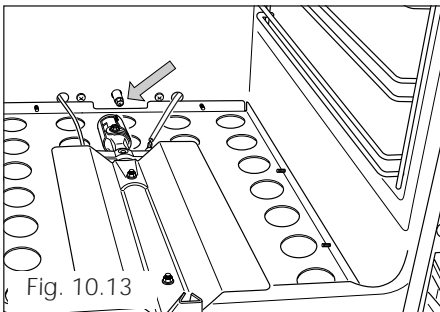
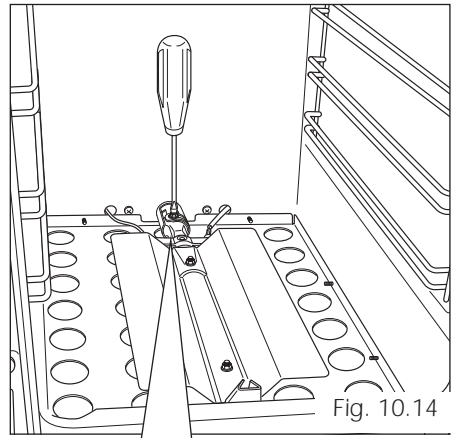

## LEFT and RIGHT OVENS

### REGULATING OF THE OVEN MINIMUM

This needs to be done only for the oven burner (the grill of the left oven is a fixed capacity) by acting on the thermostat.

Considering that in the minimum position the flame must have a length of about 4 mm and must remain lit even with a brusque passage from the maximum position to that of minimum.

The flame adjustment is done in the following way:

- Light the oven taking the knob to max. position (**230** ★).
- remove the knob and by a thin screwdriver (3 mm section - 100 mm long) unscrew of about a half turn the screw by-pass **G**, passing through the front panel hole (fig. 10.15)
- fit the knob and let the oven heat for 10 minutes, then take the knob to position **130** allowing the thermostat to work under by-pass.
- after further removal of the knob, stop slowly the screw by-pass **G** (being careful not to turn the knob rod) until the flame reaches 3-4 mm high.

**N.B.** For LPG the by-pass screw must be fixed thoroughly.

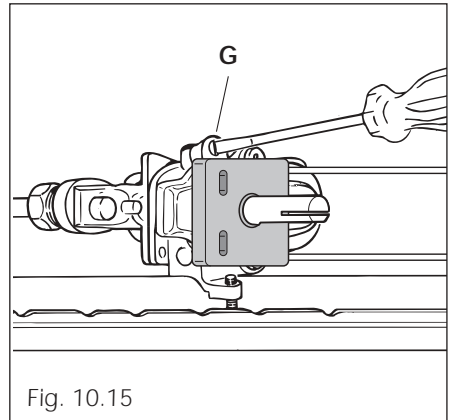

Fig. 10.15

Flame faulty in primary air	Flame correct	Flame with excess primary air
long, yellow and trembling	clear interior blue cone	short and sharp too blue interior cone tending to detach
<b>CAUSE</b>		
air regulating tube, too closed	correct distance of the tube	air regulating tube, too open



Flame correct



Flame faulty in primary air



Flame with excess primary air

### LUBRICATION OF THE GAS TAPS

If the gas tap becomes stiff, it is necessary to dismount it accurately clean it with gasoline and spread a bit of special grease resistant to high temperatures on it.

The operations must be executed by a qualified technician.

#### IMPORTANT

**All intervention regarding installation maintenance and conversion of the appliance must be fulfilled with original factory parts.**

**The manufacturer declines any liability resulting from the non-compliance of this obligation.**

**FOR YOUR SAFETY PLEASE READ THE FOLLOWING INFORMATION:**

This appliance must be installed by a qualified technician according with the current local regulations and in compliance with the manufacturer instructions.

This appliance is supplied with a moulded 13 amp three pin mains plug with a 3 amp fuse fitted. Should the fuse require replacement, it must be replaced with a fuse rated at 3 amp and approved by ASTA or BSI to BS 1362.

The plug contains a removable fuse cover that must be refitted when the fuse is replaced. In the event of the fuse cover being lost or damaged, the plug must not be used until a replacement cover has been obtained. Replacement fuse covers can be purchased from your nearest electrical dealer and must be the same colour as the original.

IF THE MOULDED MAINS PLUG IS UNSUITABLE FOR THE SOCKET OUTLET IN YOUR HOME OR IS REMOVED FOR ANY OTHER REASON, THEN THE FUSE SHOULD BE REMOVED AND THE CUT OFF PLUG DISPOSED OF SAFELY TO PREVENT THE HAZARD OF ELECTRIC SHOCK.

THERE IS A DANGER OF ELECTRICAL SHOCK IF THE CUT OFF PLUG IS INSERTED INTO ANY 13 AMP SOCKET OUTLET.

If a replacement plug is to be fitted, please observe the wiring code shown below.

**Warning! This appliance must be earthed**

A properly earthed three pin plug (fused at 3 amps, to BS 1362 ASTA approved) must be used. As the colours of the wires in the mains lead of this appliance may not correspond with the coloured markings identifying the terminals in your plug, proceed as follows.

The wire which is coloured GREEN & YELLOW must be connected to the terminal in the plug which is marked with letter "E" or by the Earth symbol or coloured GREEN & YELLOW.

The wire which is coloured BLUE must be connected to the terminal which is marked with the letter "N" or coloured BLACK.

The wire which is coloured BROWN must be connected to the terminal which is marked with the letter "L" or coloured RED.

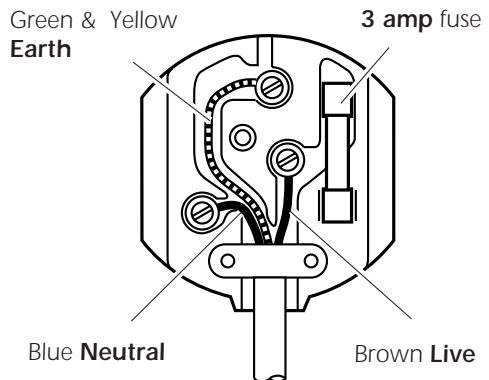

Fig. 11.1

# ELECTRICAL FEEDER CABLE CONNECTION

The operations must be executed by a qualified technician.

To connect the supply cable:

- Remove the screws securing the cover "A" on the rear of the cooker (fig. 11.2).
- Feed the supply cable through the cable clamp "D". The supply cable must be of a suitable size for the current requirements of the appliance; see the section "Feeder cable section".
- Connect the wires to the terminal block "B" as shown in the diagram in figure 11.3; or connect the phase wires to the terminal block "B" and the earth wire to the terminal PE as shown in figure 11.2.
- Take up any slack in the cable and secure with the cable clamp "D".
- Replace the cover "A".

Before effecting any intervention on the electrical parts of the appliance, the connection to the network must be interrupted.

Earth cable must be 2 cm longer than neutral and live cables.

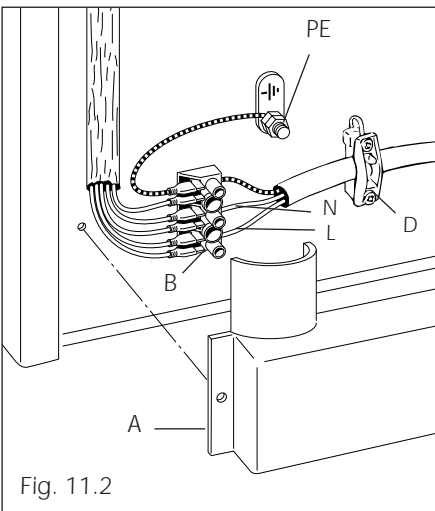

## Feeder cable section type H05RR-F

230 V ~

3 x 0,75 mm<sup>2</sup>

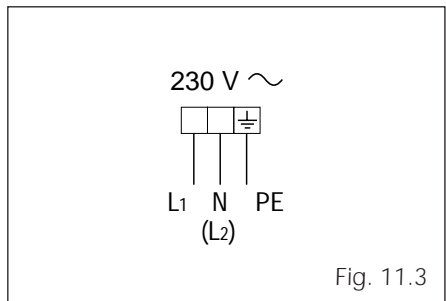



Descriptions and illustrations in this booklet are given as simply indicative. The manufacturer reserves the right, considering the characteristics of the models described here, at any time and without notice, to make eventual necessary modifications for their construction or for commercial needs.



*Living innovation*

cod. 1103172 B3