

OWNER'S MANUAL
BENETEAU 331

HULL IDENTIFICATION NUMBER:
US-BEY _ _ _ _ _

OWNER'S MANUAL BENETEAU PART #: 111570

SUMMARY:

I)	INTRODUCTION	3
II)	ANTI-FOULING	4
III)	WARRANTY	5
IV)	HULL IDENTIFICATION NUMBERS	7
V)	DEALER'S RESPONSIBILITIES	7
VI)	OWNER'S/OPERATOR'S RESPONSIBILITIES	8
VII)	SAFE OPERATION AND WARNING LABELS	12
VIII)	FEDERAL REGULATIONS	17
IX)	COMMISSIONING	20
X)	SPECIFICATIONS OF THE BOAT	23
XI)	INTERIOR LAYOUT	25
XII)	DECK	27
XIII)	SAILS AND RIGGING	28
XIV)	FRESH WATER SYSTEM	38
XV)	BILGE PUMP SYSTEM	40
XVI)	SEACOCKS AND THRU-HULLS	42
XVII)	ELECTRIC SYSTEMS	44
XVIII)	LP GAS SYSTEM	54
XIX)	EMERGENCY STEERING SYSTEM	56
XX)	ENGINE	57
XXI)	HANDLING	59
XXII)	MAINTENANCE	60
XXIII)	WINTERIZING PROCEDURES	66
XXIV)	SUPPLIER INFORMATION LIST	70
XXV)	ENVIRONMENT	72
XXVI)	CENTERBOARD SYSTEM	73

EXPLANATION OF THE TYPOGRAPHY USED:

DANGER

WARNING

TAKE CARE

RECEIPT

OWNER'S NAME

ADDRESS

.....

.....

Owner of the BENETEAU 331 number

Do certify that I have accepted delivery and read the information in the owner's manual delivered with the boat.

On

Signature

Please keep this copy for your records



RECEIPT

OWNER'S NAME :

ADDRESS :

.....

.....

Owner of the BENETEAU 331 number

Do certify that I have taken delivery and read the information in the owner's manual delivered with the boat.

On

Signature

Please send back this copy to BENETEAU USA
After Sales Dept
1313 W Hwy 76
Marion, SC 29571
U.S.A.

D) INTRODUCTION

Many parts and systems installed on your boat are supplied by other manufacturers and each carries a specific warranty and may require specific care. This manual supplements the literature supplied with the various equipment and we will refer to manufacture's literature throughout this booklet. We recommend referring to original manufacturer's literature whenever possible.

This manual is broken down into several sections to help explain your boat, your warranty, responsibilities as an owner, and maintenance of your new Beneteau. The systems and procedures described in this manual were correct to the best of our knowledge at the time of printing and may be changed at any time or may have been changed on your boat. While we have tried to describe the major points of your boat within this book, we cannot cover every detail. Please call your dealer or feel free to call us if any question should arise.

If you are a seasoned sailor much of the manual may be old news but if this is your first boat, we hope this will prove useful.

Should you need to contact Beneteau please use the following addresses and numbers, be sure to include your model and hull number with any correspondence.

Beneteau Customer Service

(Customer Service Dept.)

1313 Highway 76 West

P.O. Drawer 1218

Marion, SC 29571

Tel (843)-423-6459

Fax (843)-423-5516

Beneteau USA Inc.

(Sales & Marketing)

24 North Market Street, Suite 201

Charleston, SC 29401

Tel (843)-805-5000

Fax (843)-805-5010

We would like to sincerely thank you for choosing a Beneteau and we wish you good sailing.



II) ANTI-FOULING

The primary function of your Beneteau is to maximize your boating pleasure. Your new Beneteau was made to last through weather and time. From the very beginning, great care has been taken in building your boat. Her molds have been designed and built to resist any deformation of her lines and meticulously maintained to guarantee a superior finish. This is very important because the mold is the cocoon from which your boat emerges.

Between the gel coat layer and the fiberglass laminate, Beneteau applied a nearly impervious Vinylester layer that will virtually eliminate the phenomenon of osmotic blistering in the fiberglass hull. The addition of this product assures that the mechanical properties of your hull remain solid and it's life span is greatly improved.

All materials used in the construction of your Beneteau are of the highest quality. Sampling of materials and operational standards are constantly monitored so that the structural design matches the engineered standard.

Beneteau USA takes great care in the manufacturing of fiberglass parts, as well as in the control of raw materials and their applications. This coupled with the mastery of building techniques allows Beneteau USA to offer you the most favorable warranties in the marine industry.

Methodology for anti-fouling application when new:

1. Clean and degrease hull thoroughly using a denatured ethyl alcohol
2. Sand hull using sandpaper with a minimum grit of #220. (i.e., 400, 600, or 800)
3. Rinse with fresh water.

DO NOT USE DETERGENTS. DO NOT PRESSURE WASH.

4. APPLY ANTI-FOULING TO MANUFACTURER'S DIRECTIONS.

NOTE: It cannot be emphasized enough that thorough de-waxing must occur. Furthermore, if the gel coat is abraded with coarse sandpaper, the water imperviousness will be destroyed.

III)

LIMITED WARRANTY

Beneteau USA Inc. ("Beneteau USA") warrants to the original purchaser or any subsequent buyer during the time of this Limited Warranty (the "Owner"), that the boat, excluding parts or accessories not manufactured by Beneteau USA or Chantiers Beneteau, S.A., will be free from defects in material and workmanship for a period of ONE year from the date of the delivery to the original purchaser.

In addition, Beneteau USA warrants to the Owner, except for the prototypes and boats from the California series, that the hull and deck structure of the boat will be free from defects in material and workmanship for a period of FIVE years from the earliest of the following events: delivery of the boat to the original purchaser, first date of utilization, last day of the boat model year.

Beneteau USA's obligation under this warranty shall be limited to the repairing or replacing (or causing to be repaired or replaced), at Beneteau USA's option, the part or parts which are recognized defective by it in material or workmanship within the applicable warranty period to the exclusion of all other remedies. This Warranty shall apply only provided that the Owner presents the boat's Certificate of Origin and gives the selling dealer written notice of any claimed defect within 15 days after such defect is first discovered and satisfactory proof thereof. Warranty repairs do not result in a renewal or extension of the original Warranty for the boat or a part thereof. Transportation charges and duties shall be borne by the Owner.

This Warranty does not extend to: (1) any losses due to misuse, accident, disaster, abuse, neglect, normal wear and tear or improper maintenance; (2) boats or any part thereof which have been repaired or altered without Beneteau USA's prior written approval; (3) accessories or parts not supplied by Beneteau USA or Chantiers Beneteau, S.A., or parts or accessories installed during the process of manufacturing that were not manufactured by Beneteau USA or Chantiers Beneteau, S.A., for which the Warranty will be the one provided by the supplier of the part or accessory; (4) damages resulting from any modification made to the boat; (5) boats for rental, lease, or charter; (6) splits, discoloration, or cracks in the gel-coat (hull, rudder, and deck); (7) disorders in the hull, or deck such as, without limitation, blisterings, which are caused by use of improper maintenance products or by improper sanding of the gel-coat; (8) anti fouling, varnishes, paints, acrylon, naugahyde, fabrics, headliners, chrome, anodized coatings, keel coatings, sails, cushions, or running rigging, as these items are subject to deterioration caused by climate, erosion, normal use conditions, or wear and tear; (9) reasonable and necessary maintenance, including, but not limited to, periodic re-bedding of chain plates, stanchion bases, windows and/or window frames, and winches; (10) damages or deterioration due to the non-observance of maintenance recommendations as described in the owner's manual or non-compliance with the normal rules of boat maintenance; (11) failure to take reasonable measures necessary to protect the boat; (12) any damage or deterioration to the boat resulting from participation in a competitive sporting event.

In addition, if (1) any structural damage to the boat is suffered as a result of any cause other than a defect in material or workmanship (whether or not such damage requires or results in any repairs to the hull or deck), or (2) any repairs or alterations to the boat of any nature whatsoever are made at a shipyard not approved in writing by Beneteau USA, then the five-year hull/deck Warranty set forth above will immediately thereupon terminate and be of no further force or effect.

THIS WARRANTY IS EXPRESSLY IN LIEU OF ALL OTHER WARRANTIES EXPRESS OR IMPLIED INCLUDING WITHOUT LIMITATION THE IMPLIED WARRANTIES OF MERCHANTABILITY OR FITNESS FOR A PARTICULAR PURPOSE AND ALL OTHER LIABILITIES ON BENETEAU USA'S PART, AND BENETEAU USA NEITHER ASSUMES, NOR AUTHORIZES ANY PERSON, INCLUDING THE DEALER, TO ASSUME FOR IT, ANY OTHER LIABILITY IN CONNECTION WITH THE SALE OF BENETEAU USA'S BOATS.

Beneteau shall in no event be liable to the Owner or any other person or entity for damages of any kind, including but not limited to direct, indirect, special or consequential damages, arising from the sale or in connection with the use or inability to use the boat for any purpose whatsoever, irrespective of whether the claims or actions for such damages are based upon contract, tort, negligence, strict liability, warranty, or otherwise.

For the purpose of compliance with the Federal Boat Safety Act of 1971 and all notification procedures set forth therein, Beneteau USA requests that you complete the information requested below concerning your current address, which shall be returned to Beneteau USA by your Dealer.

Beneteau USA reserves the right, at any time, to make changes in design or additions to or improvements in the boats without liability or obligation to incorporate such change, addition, or improvement in any boat manufactured prior thereto.

This Warranty gives you specific legal rights. You may also have other rights which vary from state to state.

I hereby acknowledge that Beneteau USA Inc. Limited Warranty was attached to Dealer's purchase order in its entirety at the time that I purchased my boat from said Dealer; that I have read such Limited Warranty in its entirety; and that I have a copy of such Limited Warranty, as attached to Dealer's purchase order, for future reference.

_____	Boat Model _____
Signature	
_____	Hull # _____
Purchaser's Name/Please Print Clearly	
_____	Dealer _____
Mailing Address of Purchaser	

City State Zip	Date _____

(Area Code)	Telephone Number _____

WARRANTY/REGISTRATION PROCEDURES

Warranty Procedure

All Beneteau boats carry a one year limited warranty, as well as an extended hull and deck structural warranty (see warranty form for details). As the first owner of your new Beneteau, your warranty only becomes valid upon receipt, by Beneteau, of the completed and signed warranty form. It is important that you were presented with this document at the time of your contract with your dealer and that both you and your dealer have signed this form. Your warranty will then take effect upon final delivery to you of your new Beneteau.

Registration Procedure

As a new Beneteau owner you will automatically become a member of Club Beneteau. Club Beneteau will entitle you to many added benefits and advantages as well as providing you with a valuable line of communication with Beneteau. We will forward a new owner's package directly to 30 day after receipt of the completed and signed warranty form from your dealer.

Subsequent owners of Beneteaus are invited to become a member of Club Beneteau as well. We will automatically enroll these boat owners upon receipt of their warranty transfer cards.

In the event that you change your address, please fill out and mail in the change of address card at the back of the manual (to the address below) so that you will not miss any of Club Beneteau's opportunities. You can also find a change of address form on line under CLUB BENETEAU at www.beneteauusa.com.

If you have any questions concerning this procedure please feel free to contact Beneteau Customer Service at (843) 805-5000.

Warranty Transfer

Your new Beneteau has a transferable, limited hull and deck warranty. In the event of selling your Beneteau, the new owner must be registered with Beneteau within 30 days of the date of sale for the warranty to be transferred.

Please fill in the appropriate warranty registration card at the back of this owner's manual and mail it to:

Beneteau USA Inc.
24 North Market Street
Suite 201
Charleston, SC 29401

IV) HULL IDENTIFICATION NUMBERS

The hull identification or "BEY" number is a unique number given to your Beneteau alone. This number begins with "BEY" which has been assigned to Beneteau by the USCG followed by an alpha-numeric code which details the model, serial no., month of construction, year of construction and model year.

Please clearly identify your boat using your model and "BEY" number during any correspondence with Beneteau.

Your boat identification number appears in two places:

The main hull identification number is located on the aft starboard side, near THE transom, stamped into the hull, approximately 3 inches below the toerail.

The second hull identification number is in a hidden area for anti-theft purposes.

V) DEALER'S RESPONSIBILITIES

Your Beneteau Dealer is part of a worldwide distribution network, with dealers in 28 countries. As a Beneteau Dealer, he has certain obligations to you as our customer and to Beneteau as our representative. A Dealer's responsibility does not end with the sale of your boat. Your Dealer is responsible for the following:

- Deliver your new Beneteau to you complete as ordered in your purchase agreement.
- Preparation of your boat for commissioning by their personnel, another yard or by providing you with the correct commissioning procedures.
- Checking of all systems on the boat for fit, proper function and to familiarize you with the usage of each system.
- Sea trial of your new Beneteau with you as a final verification that all systems are in good order.
- Providing customer support and parts after you take delivery and any warranty service under the terms of the limited warranty. All warranty questions/claims or processing should be directed through your dealer.

VI) OWNER'S/OPERATOR'S RESPONSIBILITIES

STATE REGISTRATION OR FEDERAL DOCUMENTATION

For State Registration please consult your Dealer or the State Marine Police, who can provide the correct governmental department handling registration in your state.

SAFETY AND MAINTENANCE

For maximum enjoyment of your Beneteau, due respect should be given to proper safety and maintenance procedures.

Be sure that your boat is operated according to the U.S. Coast Guard Regulations as outlined in the "Federal Requirements for Recreational Boats". Please familiarize yourself with all operating requirements.

Prepare yourself for any situation before going out on the water. Follow the instructions provided in the sections of this owner's manual, the individual supplier instruction manuals, and all applicable U.S. Coast Guard and other regulations. If you are not an experienced sailor, you should complete an accredited sailing course.

Before leaving the dock, be sure that all your equipment is in working order, that you are aware of the weather conditions, and someone ashore is familiar with your destination or sailing activities.

MANDATORY COAST GUARD SAFETY EQUIPMENT

Many safety items are required for compliance with the U.S. Coast Guard regulations. Note that these regulations are subject to change. It is the owner's responsibility to be aware of current regulations as outlined in the "Federal Requirements for Recreational Boats". For your convenience a copy is included with your yacht's documentation, and additional copies may be obtained by calling the U.S. Coast Guard Boating Safety Hotline at (800) 368-5647.

Good safety equipment should be a priority of every sailor for the protection and comfort of passengers. Passengers aboard should be made familiar with the safety equipment and operation of the boat in the event of an emergency.

Depending on the length, passenger capacity, and operating conditions, your boat must be equipped according to the current USCG requirements. Be sure that you operate your boat with the necessary number of life preservers, fire extinguishers, signaling devices, distress signals, navigation lights as referred to in the "Federal Requirements for Recreational Boats."

RECOMMENDED SAFETY EQUIPMENT

Preparation is the key to safety on the water.

Your new Beneteau has been fitted with the following equipment:

- Compass - be sure that it is properly calibrated to give the correct magnetic reading.
- A large capacity bilge pump.

We recommend that you fully outfit your Beneteau with safety equipment that can be obtained through your dealer or marine supply outlets. These items should include but not be limited to:

- Up to date nautical charts covering your intended cruising area.
- Boat hook.
- Large waterproof flashlight with spare batteries.
- Fenders.
- Docking lines - a good rule of thumb to follow dictates that your bow, stern, and spring line be equal to the length of the boat.
- Life jackets, anchor, anchor chain and line, throwing line, flares, soft wooden plugs for thru-hulls, life ring, fire extinguisher, and foghorn.
- Electronics - Depth Sounder, Log Speedometer, and VHF Radio.

SAFETY COURSES

It is recommended that owners and operators gain knowledge and experience in boat safety skills such as:

- (a) Navigation
- (b) Seamanship and boat handling
- (c) Rules of the road, international and inland waterway
- (d) Weather prediction
- (e) Safety at sea
- (f) Survival in bad weather
- (g) Respect for others on the water
- (h) First aid
- (i) Radio communication
- (j) Distress signals
- (k) Pollution controls

To find out where one can attend these courses in your area, please call your dealer or "The Boaters Educational Course Line" at (800) 336-2628.

ANCHORING

Various sea and bottom conditions require different anchoring systems. Your dealer can help in choosing rode size and length, anchor chains, and working and storm anchors most appropriate for your boat and location.

In general, a minimum of two anchors should be carried at all times and enough anchor rode and chain necessary for the depth of water to be navigated during storm conditions.

Certain anchors are useful for a variety of bottom conditions. Study the charts of the area to be navigated for information concerning bottom conditions and water depth.

The greatest hazard with a sound permanent mooring is the chafe, which can occur to the rode at the bow chocks. This is the single most common site of failure. Care is advised in the selection and protection of the rode pennant with appropriate chafing gear. Careful and regular inspection of moored boats on a regular basis is necessary to ensure the boat's safety.

ADDITIONAL SAFETY EQUIPMENT

A number of additional safety items are worthy of your consideration. These range from safety harnesses to emergency beacons, life rafts, and survival suits. Their use depends upon the intended use of the yacht. We suggest you investigate the necessity of these items through discussion with your dealer or local chandler.

MEDICAL KIT

Every yacht should carry a first aid manual, and a medical kit tailored to the specific needs of the owner. Any ship's store should carry a standard type medical kit. Items in the kit should include but not be limited to the following:

- Aspirin
- Adhesive strips and tape
- Antiseptic wipes
- Gauze bandages
- Sunscreen first aid/burn cream
- Sterile pads
- Ace bandages & splints
- Motion sickness pills
- Ammonia inhalants
- Antiseptic germicide ointment
- Zinc oxide ointment
- Insect/bee sting relief ointment/spray
- Cold packs for sprains
- Scissors & tweezers

TOOL KIT

A basic kit should consist of:

- Wrenches - adjustable, Metric and SAE open end, box, socket
- Hammers - large and small
- Knife - with marlinespike
- Screwdrivers - large and small, standard and Phillips
- Pliers - regular, cutting and needle nose, vise grips
- Wire cutter - capable of cutting standing rigging
- Hacksaw - with spare blades

SPARE PARTS

A basic kit should consist of the following:

- Standing and Running Rigging: Turnbuckles, monel seizing wire, clevis and cotter pins, blocks, extra line, rigging tape, duct tape.
- Fasteners: Assortment of stainless steel screws, nuts, bolts, and washers
- Hose clamps.
- Electrical: Electrical tape, wire, crimps on lugs, spare navigation light bulbs.
- Lubricating supplies: WD-40 and silicone grease.
- Engine: Check engine manual for spare parts, engine oil and transmission fluid recommendations.
- Sails: Sail repair kit and sail slides.

VII) SAFE OPERATION AND WARNING LABELS

Ensure that the boat operator is not under the influence of drugs and/or alcohol.

Do not venture out in weather or sea conditions beyond the skill or experience of the operator.

There are "Warning" and "Caution" statements affixed to your Beneteau. These are detailed below with location:

FUEL WARNING LABEL

- Affixed to the fuel tank.

Beneteau Part #00001027

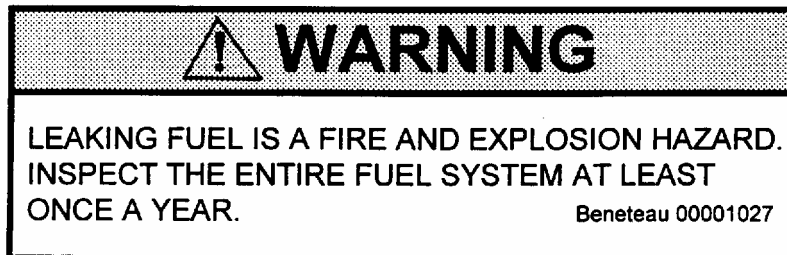

SHORE-POWER LABEL

- At the 110V distribution panel.

Beneteau Part #00001028

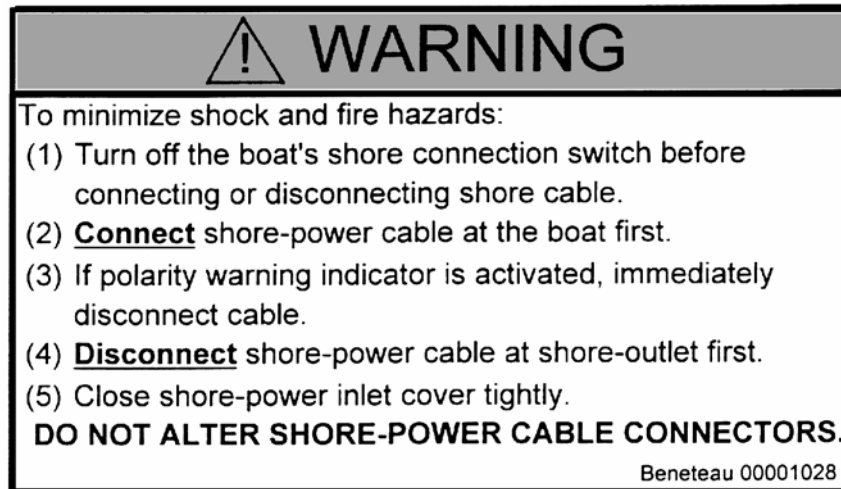

PROPANE LABELS

- At the propane stove affixed to the bulkhead in the galley

Beneteau Part #00001021

 CAUTION
<p>(1) THIS APPLIANCE IS DESIGNED FOR USE WITH LIQUEFIED PETROLEUM GAS (LPG) ONLY. DO NOT CONNECT COMPRESSED NATURAL GAS (CNG) TO THIS SYSTEM.</p> <p>(2) Keep cylinder valve(s) and solenoid valve(s) closed when boat is unattended. Close them immediately in any emergency. When on board, cylinder valve(s) or solenoid valve(s) shall be closed when appliances are not in use. Keep empty cylinder valves tightly closed.</p> <p>(3) Close appliance valve(s) before opening cylinder valve(s).</p> <p>(4) Test LPG system as recommended in sign posted in vicinity of LPG cylinder.</p> <p>(5) Apply ignition source to burner before opening appliance valve.</p> <p>NEVER USE FLAME TO TEST FOR LEAKS.</p> <p>Beneteau 00001021</p>

Beneteau Part #00001026

 WARNING
<p>OPEN FLAME COOKING APPLIANCES CONSUME OXYGEN THIS CAN CAUSE ASPHYXIATION OR DEATH MAINTAIN OPEN VENTILATION DO NOT USE THIS APPLIANCE FOR COMFORT HEATING</p> <p>Beneteau 00001026</p>

- In the propane locker affixed under the propane locker lid

Beneteau Part #00001024

**CAUTION**

- (1) **THIS SYSTEM IS DESIGNED FOR USE WITH LIQUEFIED PETROLEUM GAS (LPG) ONLY, DO NOT CONNECT COMPRESSED NATURAL GAS (CNG) TO THIS SYSTEM.**
- (2) Keep cylinder valve(s) and solenoid valve(s) closed when boat is unattended. Close them immediately in any emergency. When on board, cylinder valve(s) or solenoid valve(s) shall be closed when appliances are not in use. Keep empty cylinder valve(s) tightly closed.
- (3) Close appliance valves before opening cylinder valve.
- (4) Test for system leakage each time the cylinder supply valve is opened for appliance use: Close all appliance valves. Open solenoid valve if installed. Open, then close cylinder supply valve. Observe pressure gauge at the regulating device and see that it remains constant for not less than three minutes before any appliance is used. If any leakage is evidenced by a pressure drop, check system with a leak detection fluid or detergent solution which does not contain ammonia and repair before operating system.
- (5) **NEVER USE FLAME TO CHECK FOR LEAKS.**

Beneteau 00001024

- On or next to the LP Gas Line

Beneteau Part #00001030

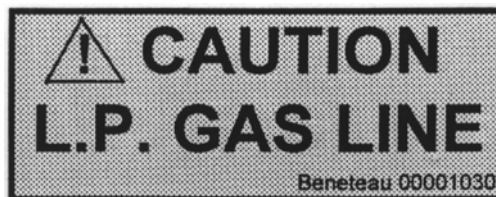

SWIM LADDER WARNING LABEL

- Located on the transom

Beneteau Part # 00001022

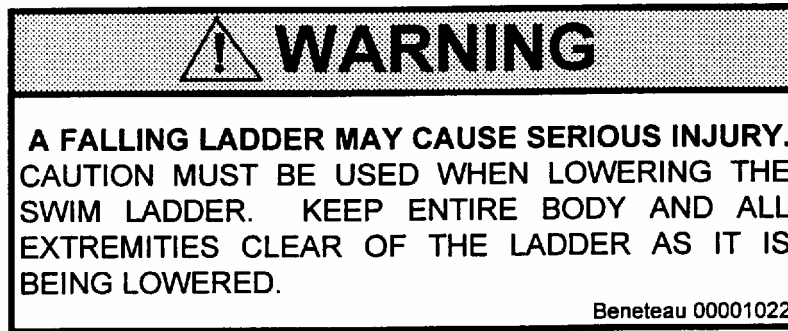

HIGH VOLTAGE WARNING LABEL

- Located beside the 110v electric panel.

Beneteau Part #00001034

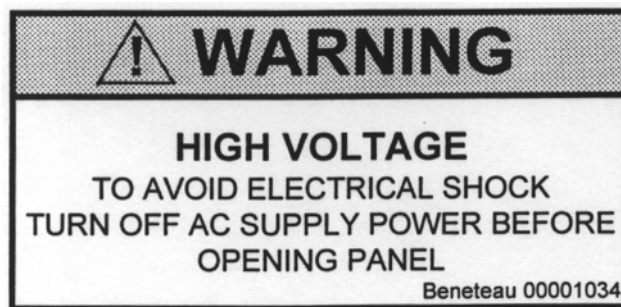

TRANSOM DOOR WARNING LABEL

- Located on or next to the helmsman's seat. (Not applicable on all models)

Beneteau Part #00001031



STANDARD BATTERY SWITCH LABEL

- Located at the standard battery switches.
Beneteau Part #00001032

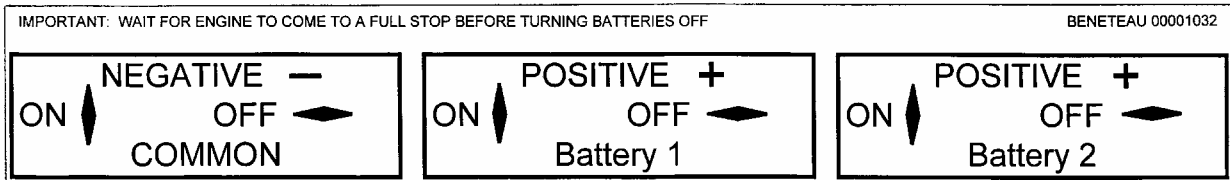

OPTIONAL BATTERY SWITCH LABEL

- Located at the optional battery switches
Beneteau Part #00001023

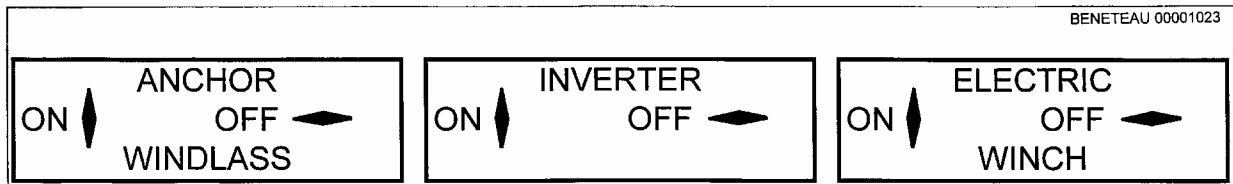

LIFTING SLING LOCATION ARROWS LABEL

- Located at or near the hull to deck joint
Beneteau Part #00001033

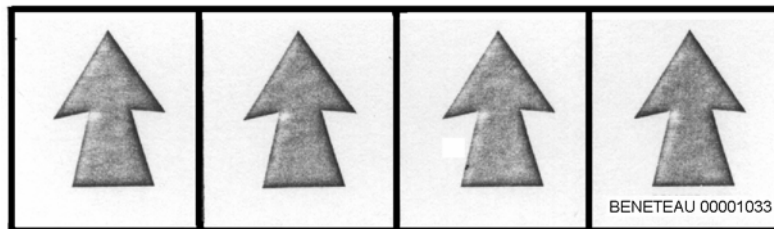

ANTI FREEZE CAUTION TAG

- Tied to the breaker for the water
Beneteau Part #00001038

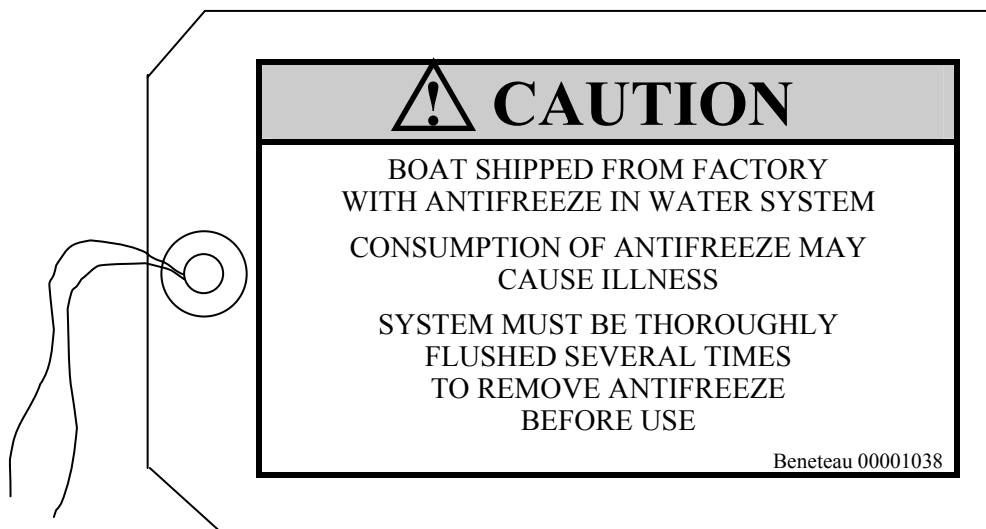

VIII) FEDERAL/STATE REGULATIONS

DISCHARGE OF OIL

- Located: under the sail locker lid.

Beneteau Part #00001007

DISCHARGE OF OIL PROHIBITED

The Federal Water Pollution Control Act prohibits the discharge of oil or oily waste into or upon the navigable waters of the United States or waters of the contiguous zone if such discharge causes a film or sheen upon, or discoloration of, the surface of the water, or causes a sludge or emulsion beneath the surface of the water. Violators are subject to a penalty of \$5,000.

BENETEAU

0000 1007

SOLID WASTE DISPOSAL

- Located under the sail locker lid.

Beneteau Part #00001025

<p>It is illegal for any vessel to dump plastic trash anywhere in the ocean or navigable waters of the United States. Annex V of the MARPOL TREATY is an International</p>		<p>Law for a cleaner, safer marine environment. Violation of these requirements may result in civil penalty up to \$25,000, fine and imprisonment.</p>	
<p>3 Miles from Shore</p>	<p>3-12 Miles from Shore</p>	<p>12-25 Miles from Shore</p>	<p>Outside 25 Miles</p>
<p>U.S. Lakes, Rivers, Bays and Sounds ILLEGAL TO DUMP Plastic & Garbage, Paper, Rags, Glass, Food, Metal, Crockery, Dunnage.</p>	<p>ILLEGAL TO DUMP Plastic, Dunnage, lining & packing materials that float, also if not ground to less than one inch; Paper, Rags, Glass, Crockery, Metal, Food</p>	<p>ILLEGAL TO DUMP Plastic, Dunnage, lining & packing materials that float</p>	<p>ILLEGAL TO DUMP Plastic</p>
<p>State and local regulations may further restrict the disposal of garbage.</p>			<p>BENETEAU 00001025</p>

MARINE SANITATION

Your Beneteau is equipped with an USCG approved marine head and holding tank.

By law you must use a holding tank in all U.S. waters, Check with local authorities for regional laws governing your area before selecting the overboard discharge option.

ACCIDENT REPORTING

Knowledge of accident reporting requirements. Please refer to the following list for a copy of the U.S. Coast Guard Boating Accident form. For further information on where to obtain more forms, please call the U.S. Coast Guard Boating Safety Hotline at (800) 368-5647

NATIONAL VESSEL DOCUMENTATION CENTER
2039 STONEWALL JACKSON DR.
FALLING WATERS, WV 25419
TOLL FREE: 1-800-799-8362
PHONE: (304) 271-2400
FAX: (304) 271-2405

RENDERING ASSISTANCE

United States Code, Title 46:

"The owner or operator of a vessel is required by law to render assistance to any individual or vessel in distress, so long as his vessel is not endangered in the process."

IX) COMMISSIONING

COMMISSIONING PROCEDURES

The first commissioning of a yacht is essentially the start of its life, and the importance of proper commissioning procedures at this time cannot be overstated. The first commissioning procedure must be performed by Beneteau dealer personnel or those authorized by them. The dealer will also have a commissioning checklist to be signed by the owner and a dealer representative at the time of the first commissioning. The owner also needs to concern himself with items such as safety equipment, which is considered to be his responsibility. See the Owner's Operator's Responsibilities section for details.

Lists of the pre-launch and post-launch checks employed during commissioning are provided in this section for those owners interested in understanding the decommissioning procedure, as well as for future use in any recommissionings that may be required after periods of wet or dry storage. The lists are of a general nature and do not attempt to provide step-by-step instructions.

The following is a list of minimum commissioning duties. Additional operations may be required dependent upon the model & equipment

PRIOR TO LAUNCH

- _____ All accessories & options supplied per shipping list and boat order
- _____ Check hull and repair any shipping damage - aft end of keel, rudder, etc.
- _____ Prep bottom and apply bottom paint if needed.
- _____ Thru hulls inspected and closed.
- _____ Clean hull thoroughly.
- _____ Check clamps on all thru hulls below waterline.
- _____ Wax hull topsides.
- _____ Dock lines and fenders aboard.
- _____ Check tightness of nuts on prop shaft and zinc. (Folding props require additional steps).
- _____ Check steering system (rudder moving freely stop to stop and does not touch hull?).
(Hydraulic steering requires all fittings be checked and the system is bled)
- _____ Zincs installed.
- _____ Thru hulls unobstructed and speed/log impeller in place (if applicable).
- _____ Fuel valve turned ON.
- _____ Check keel bolts for tightness.

OPERATIONS AFTER LAUNCH

- _____ No water leaks, stuffing box, shaft log, strut, rudder post.
- _____ No leaks at thru hulls; all hose clamps secure with seacocks open.
- _____ Fill water tanks, no leaks at fill pipes, overflows or connections.
- _____ Fill fuel tank.
- _____ Batteries secured, connected, filled and charged.
- _____ Check all cabin lights.
- _____ Check all navigation lights.
- _____ Water pressure system - air bled, no leaks at connections.
- _____ Check electric sump pumps and bilge pump.
- _____ Check manual bilge pump
- _____ Check emergency tiller fit.
- _____ 110V shore power polarity ok and breakers on
- _____ Battery charger ok.
- _____ Hot water heater works-must be filled before turning on.
- _____ Check head operation and holding tank for leaks.
- _____ Test wash down pumps, refrigeration, heaters, etc.
- _____ Test stove and LPG tank for leaks and proper operation
- _____ **DO NOT TEST FOR LEAKS WITH AN OPEN FLAME, WIPE EACH JOINT WITH A SOAPY SOLUTION AND LOOK FOR BUBBLES**

ENGINE START-UP

- _____ Check transmission for proper fluid and proper level.
- _____ Check crankcase dipstick for proper fluid and proper level.
- _____ Check shift and throttle cables for proper adjustment and secure end fittings.
- _____ Engine alarms work when key is on.
- _____ Open engine water intake.
- _____ Start engine, check gauges and water flow at exhaust is normal.
- _____ Check water level in heat exchanger and expansion tank.
- _____ Check belts and mounts.
- _____ Run engine at operating temperature. Note temperature _____degrees.
- _____ No engine or fuel line leaks-no chafe problems with wires.
- _____ Forward and reverse gears operate.
- _____ After warm-up, shut engine down, check oil, and fluid levels again.
- _____ Alignment to under .003 - coupling bolts tightened.
- _____ Idle set correctly, 800 ± RPM, engine won't stall when put in gear.
- _____ Allow engine to run for at least (1) hour.
- _____ No leaks at the shaft seal.
- _____ Shift and throttle operate smoothly with engine running.
- _____ No leaks at keel bolts after engine run.

PRIOR TO STEPPING MAST

- _____ Clean or wax spar.
- _____ Mast sheaves free running.
- _____ Run halyards if necessary– Make sure you have clean hands on clean ground.
- _____ Attach and secure all stays and shrouds.
- _____ Attach and secure spreaders to mast and upper shrouds.
- _____ Check boom gooseneck fitting.
- _____ Install mast boot on spar if applicable.
- _____ Check all mast lights.
- _____ Attach and secure boom topping lift.
- _____ Check running lights and electrical connections.
- _____ Protect against chafe on spreader ends and any fitting.
- _____ Check sail track for burrs.
- _____ Turnbuckles attached.
- _____ Re-check all pins, cotters, and Loctite any shackles.
- _____ Check with salesman and work order for additional mast gear.
- _____ Furling system built and connected to mast

AFTER STEPPING MAST

- _____ Protect spar from scratching on mast collar on keel stepped masts.
- _____ Turnbuckles lubricated.
- _____ Attach standing rigging to chain plates.
- _____ Chock mast partner and seal mast boot on keel stepped masts.
- _____ All mast wiring connected.
- _____ Preliminary tune - spar straight - shrouds proper tension.
- _____ Run reefing lines and halyards.
- _____ All cotter pins in place on turnbuckles and opened.
- _____ Run main sheets and attach topping lift.
- _____ Tape chain plates and cotter pins to prevent chafe.
- _____ Check and double-check all turnbuckles, cotter and clevis pins.

PRIOR TO DELIVERY

- _____ Hose test all ports, deck hardware, chain plates, and stanchion posts for leaks.
- _____ Tighten lifelines and tape split rings.
- _____ All doors, drawers, floorboards, hatches, and cabinets operate freely - fit if necessary.
- _____ Clean thoroughly: sinks, bulkheads and counter tops, all lockers and drawers, bilge, cushions, deck and cockpit lockers.
- _____ Dry the bilge completely.
- _____ Clean and oil exterior teak if needed.
- _____ Clean cabin sole, deck area and ports.
- _____ All Coast Guard and safety gear aboard.
- _____ Sails bent on, **ALL HEADSAILS FIT FURLING.**
- _____ All electronics and optional gear tested and working.

X) SPECIFICATIONS OF THE BOAT

Type BENETEAU 331
 Name of Builder BENETEAU USA INC.
 Design Category..... A
 No. of acknowledged body..... CE 0607

Hull Length :	10.00 m	(32.81 ft)
Hull Beam	3.42 m	(11.22 ft)
Draft:	Shoal Keel :	1.31 m (4.30ft)
	Deep Keel :	1.65 m (5.41 ft)
	Centerboard up :	0.90 m (2.95 ft)
	Centerboard down :	2.10 m (6.89 ft)
Clearance Height	13.80 m	(45.28 ft)

Maximum Authorized Engine Power :	25 kW	(33 hp)
-----------------------------------	-------	---------

Fuel Capacity	70 L (18.5 US gal)
Fresh Water Capacity	170 L (45 US gal)
Battery Capacity	100A engine 100A house

DESIGN CATEGORIES

- Category A: OCEAN – Designed for extended voyages where conditions may exceed wind force 8 (Beaufort scale) and significant wave heights of 4 m and above, and vessels largely self sufficient
- Category B: OFFSHORE – Designed for offshore voyages where conditions up to, and including, wind force 8 and significant wave heights up to, and including, 4 m may be experienced.
- Category C: INSHORE – Designed for voyages in coastal waters, large bays, estuaries, lakes and rivers where conditions up to, and including, wind force 6 and significant wave heights up to, and including, 2 m may be experienced.
- Category D: SHELTERED WATERS – Designed for voyages on small lakes, rivers, and canals where conditions up to, and including, wind force 4 and significant wave heights up to, and including, 0.5 m may be experienced.

Category	Height of the Waves	Wind Force (Beaufort)
A	> 4 m (13.0 ft)	> 8
B	< 4 m (13.0 ft)	≤ 8
C	< 2 m (6.5 ft)	≤ 6
D	< .5 m (1.6 ft)	≤ 4

For additional information concerning the standard equipment, please refer to the manuals enclosed with the boat.

Maximum recommended number of persons on board by design category:

Category	Maximum Number of Persons <i>Boat with Deep Keel</i>	Maximum Number of Persons <i>Boat with Shoal Keel</i>	Maximum Number of Persons <i>Boat with Centerboard</i>
A	6	-	-
B	8	8	8
C	8	8	8
D	10	10	10

The C.E. Certified equipment includes: The fuel tanks, parts of the steering system, parts of the gas system and the hatches and portholes.

WEIGHT ESTIMATION

SAILING CATEGORIES	A	B	C	D
	Kg (lbs)	Kg (lbs)	Kg (lbs)	Kg (lbs)
Light Boat :	4968 (10,953)	4968 (10,953)	4968 (10,953)	4968 (10,953)
Safety Equipment :	60 (132)	60 (132)	60 (132)	60 (132)
Sails :	40 (88)	40 (88)	40 (88)	40 (88)
Light Displacement:	5068 (11,173)	5068 (11,173)	5068 (11,173)	5068 (11,173)
Life Raft :	74 (163)	74 (163)	74 (163)	74 (163)
Rest of Crew :	450 (992)	600 (1,323)	600 (1,323)	750 (1,654)
Water :	170 (375)	170 (375)	170 (375)	170 (375)
Fuel :	56 (123)	56 (123)	56 (123)	56 (123)
Personal Equipment:	150 (331)	200 (441)	200 (441)	250 (551)
Optional Equipment				
Additional Water Tank:	140 (309)	140 (309)	140 (309)	140 (309)
Holding Tank :	50 (110)	50 (110)	50 (110)	50 (110)
Air Conditioning :	80 (176)	80 (176)	80 (176)	80 (176)
Auto Pilot Gear :	20 (44)	20 (44)	20 (44)	20 (44)
Spinnaker Rigging :	10 (22)	10 (22)	10 (22)	10 (22)
Microwave Oven :	5 (11)	5 (11)	5 (11)	5 (11)
Roof Sprayhood :	20 (44)	20 (44)	20 (44)	20 (44)
Bimini Top :	20 (44)	20 (44)	20 (44)	20 (44)
Fridge:	20 (44)	20 (44)	20 (44)	20 (44)
SUB TOTAL (Optional Equipment)	365 (804)	365 (804)	365 (804)	365 (804)
Margin for Extra Equipment	490 (1080)	290 (639)	290 (639)	90 (198)

MAXIMUM LOAD DISPLACEMENT Kg (Lbs.)	6823 (15,042)	6823 (15,042)	6823 (15,042)	6823 (15,042)
--	----------------------	----------------------	----------------------	----------------------

MAXIMUM LOAD Kg (Lbs.)	1755 (3,869)	1755 (3,869)	1755 (3,869)	1755 (3,869)
-----------------------------------	---------------------	---------------------	---------------------	---------------------

MAXIMUM LOAD = MAXIMUM LOAD DISPLACEMENT – LIGHT DISPLACEMENT

ANY OVERLOADING CARRIES A RISK OF FLOODING OR LOSS OF STABILITY

XI) INTERIOR LAYOUT

2 CABIN VERSION

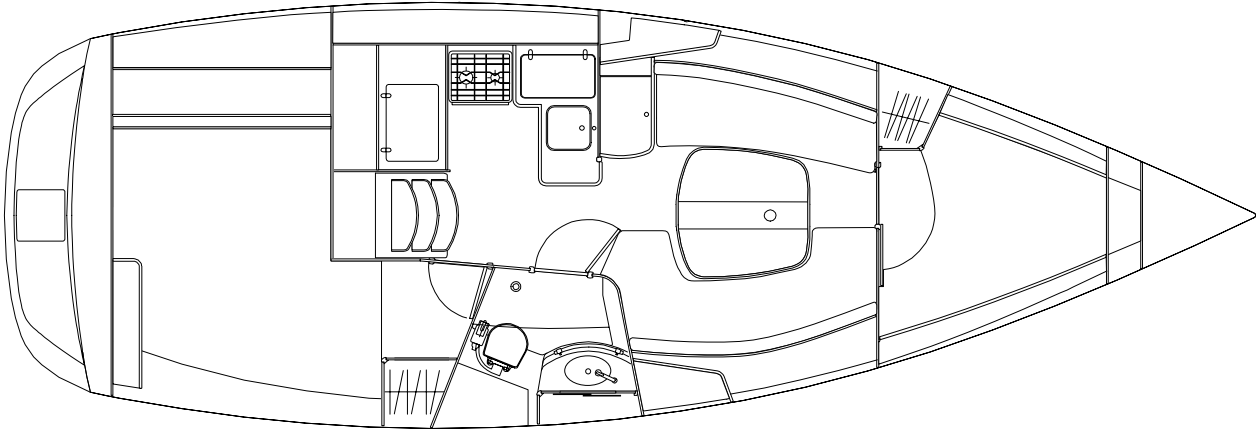

3 CABIN VERSION

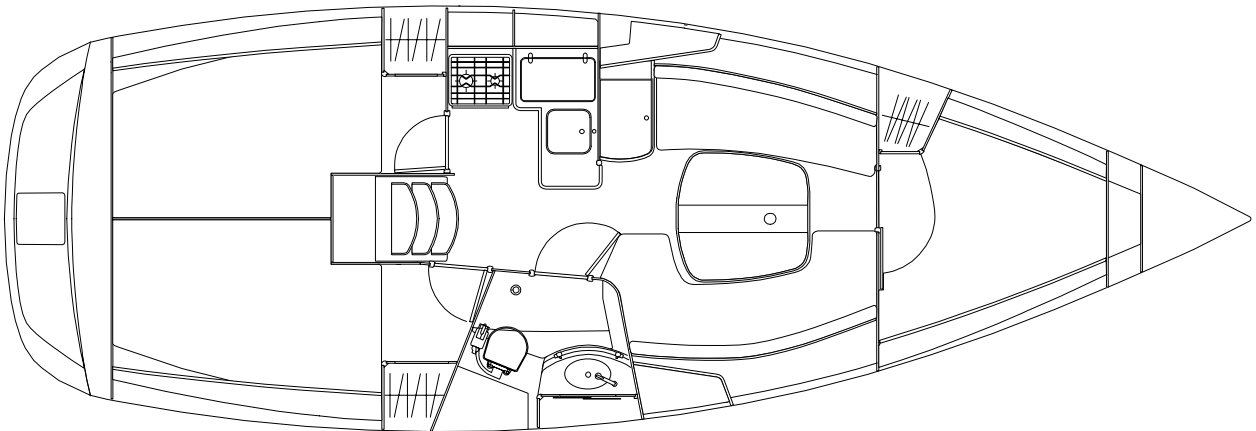

EXIT IN CASE OF FIRE

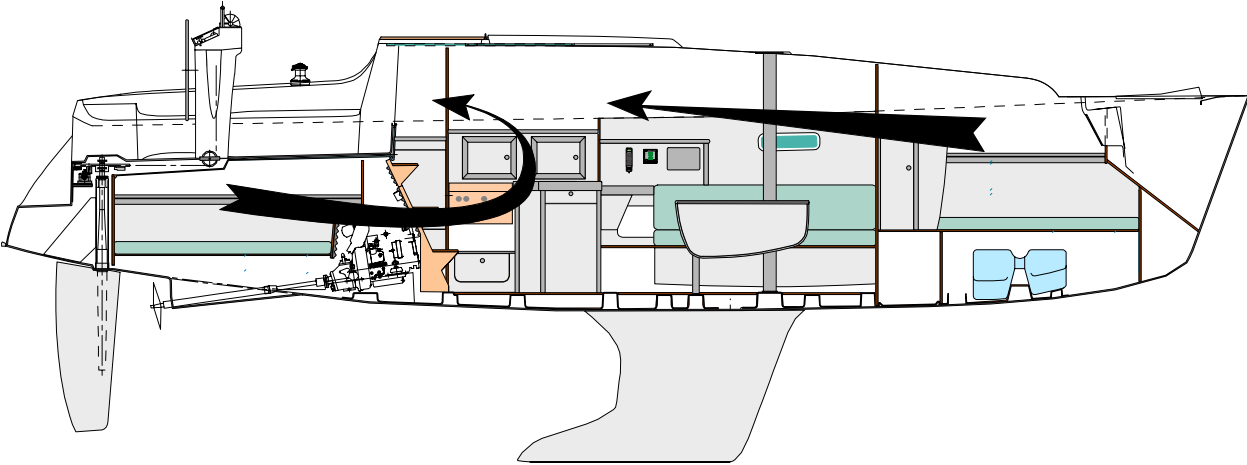

XII) DECK

- Jack lines can be fastened either to the mooring cleats or to the toe rail.

The Beneteau 331 is fitted with a foldaway swimming ladder. The swimming ladder should be in its folded/upright position as soon as you are on board.

Make sure that the hatches and portholes are closed before you put out to sea.

In case of rough sea, close the boat with the sliding hatch and weatherboards so that no water may come into the boat.

Check that nothing blocks up the cockpit drain holes; these holes should never be sealed.

- 1 Recommended location of the life-raft
- 2 Water tank deck fill
- 3 Waste tank pump out deck plate
- 4 Fuel deck fill

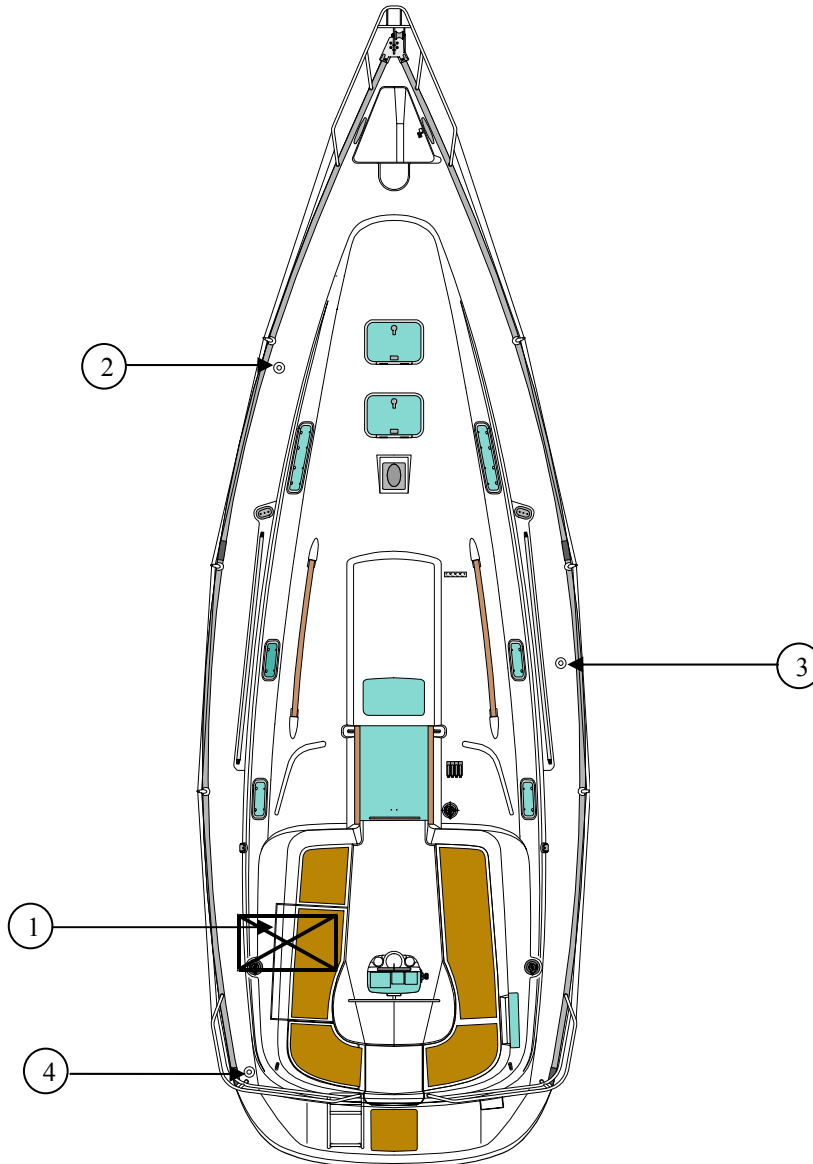

XIII) SAILS AND RIGGING

Specifications of the Sails:

SAIL	AREA	
	Roller furling main	Classic main
Total	52.22 m ²	57.30 m ²
Mainsail	20.92 m ²	26.00 m ²
Genoa (140%)	31.30 m ²	31.30 m ²

Roller furling mast		Classic mast	
I	12.50 m	I	12.50 m
J	3.76 m	J	3.76 m
P	10.40 m	P	10.54 m
E	4.28 m	E	4.35 m

Specifications of the Standing Rigging:

V: VERTICAL - D: DIAGONAL

REF	CABLE	Dia. mm	Dia. In.
1	V1D2 (Cap Shroud)	7	9/32
2	D1 AFT (Aft Lower Shroud)	8	5/16
3	Forestay	7	9/32
4	Babystay	6	7/32
5	Double Backstay	5	3/16

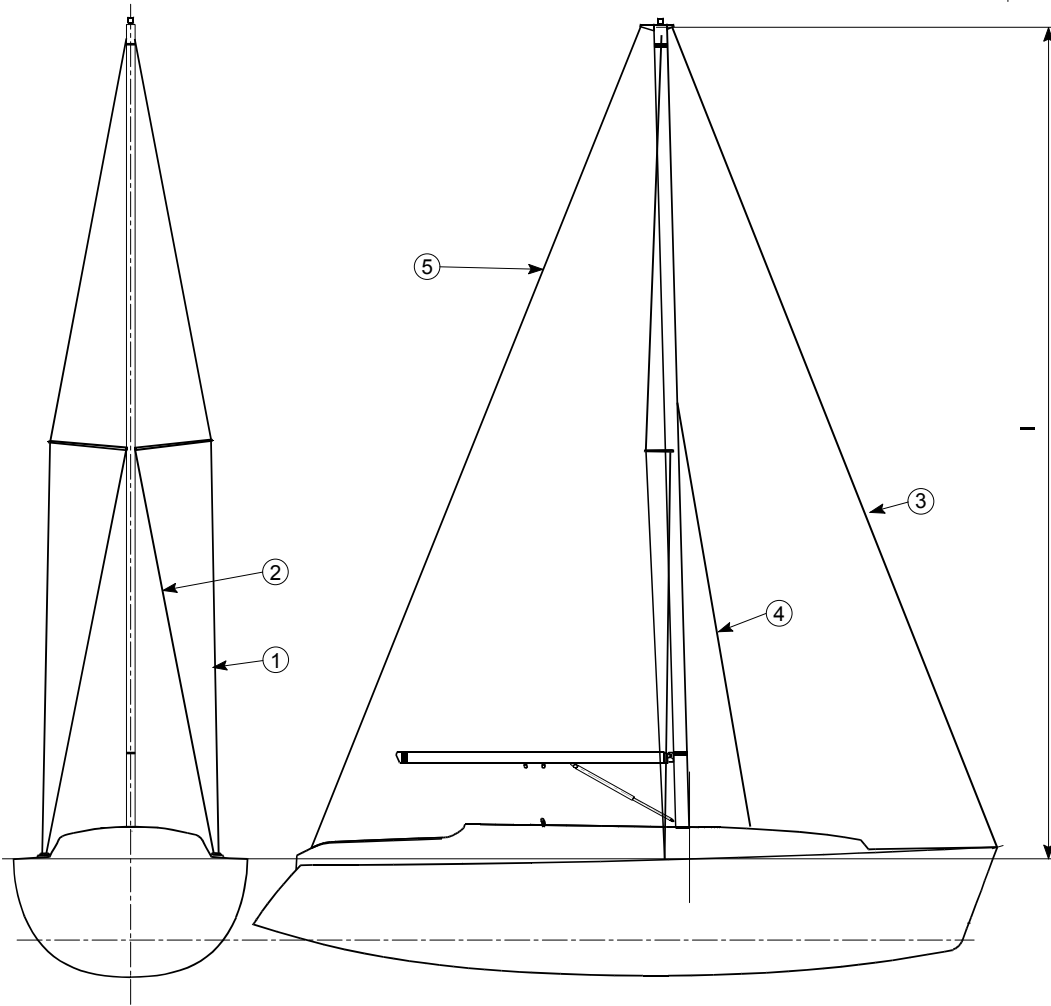
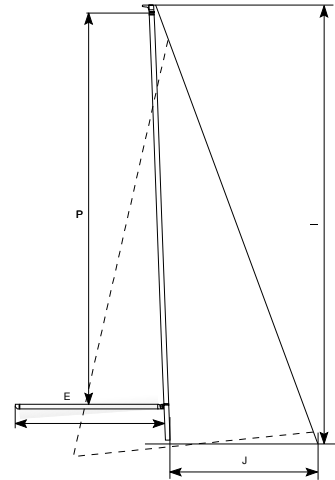

FORESTAY

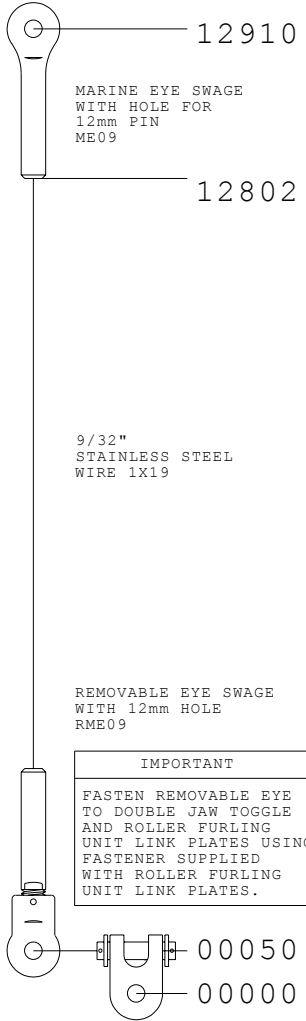

MARINE EYE SWAGE
WITH HOLE FOR
12mm PIN
ME09

9/32"
STAINLESS STEEL
WIRE 1X19

REMOVABLE EYE SWAGE
WITH 12mm HOLE
RME09

IMPORTANT
FASTEN REMOVABLE EYE
TO DOUBLE JAW TOGGLE
AND ROLLER FURLING
UNIT LINK PLATES USING
FASTENER SUPPLIED
WITH ROLLER FURLING
UNIT LINK PLATES.

JAW AND JAW TOGGLE
J2001616

BABYSTAY

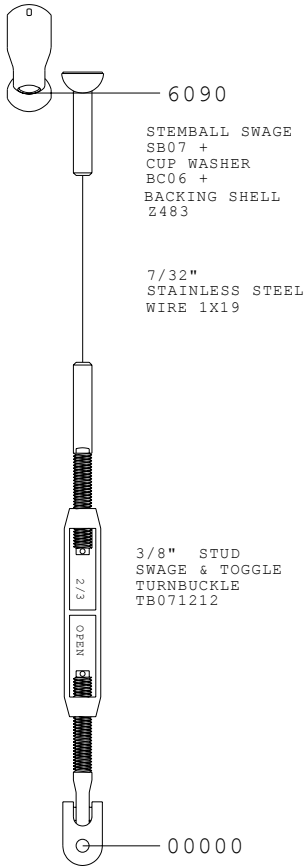

STEMBALL SWAGE
SB07 +
CUP WASHER
BC06 +
BACKING SHELL
Z483

7/32"
STAINLESS STEEL
WIRE 1X19

3/8" STUD
SWAGE & TOGGLE
TURNBUCKLE
TB071212

V1D2

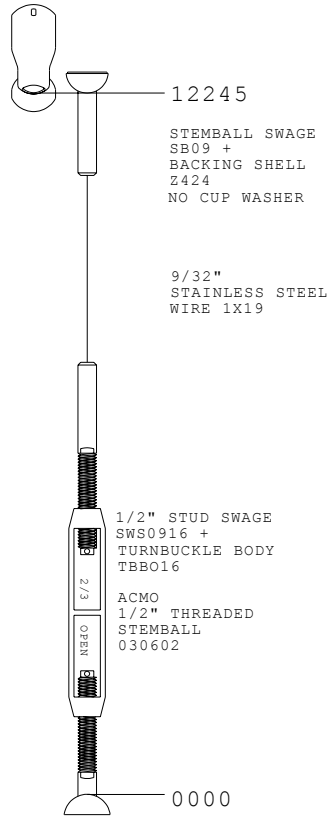

STEMBALL SWAGE
SB09 +
BACKING SHELL
Z424
NO CUP WASHER

9/32"
STAINLESS STEEL
WIRE 1X19

1/2" STUD SWAGE
SWS0916 +
TURNBUCKLE BODY
TBB016

ACMO
1/2" THREADED
STEMBALL
030602

D1 AFT

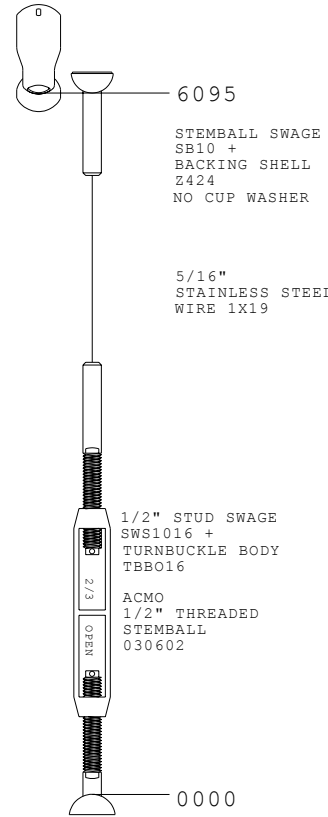

STEMBALL SWAGE
SB10 +
BACKING SHELL
Z424
NO CUP WASHER

5/16"
STAINLESS STEEL
WIRE 1X19

1/2" STUD SWAGE
SWS1016 +
TURNBUCKLE BODY
TBB016

ACMO
1/2" THREADED
STEMBALL
030602

TWIN BACKSTAYS

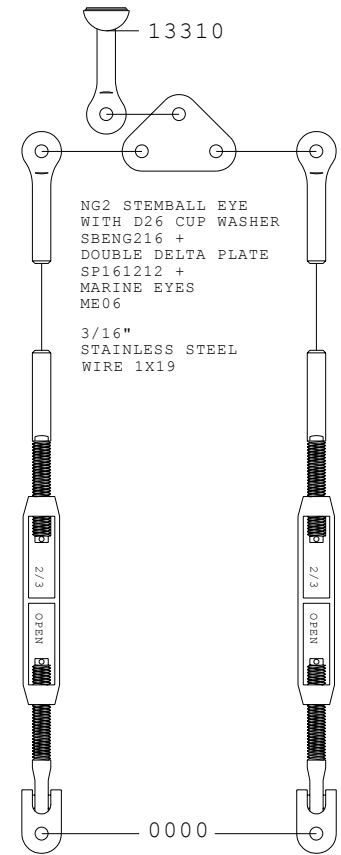

NG2 STEMBALL EYE
WITH D26 CUP WASHER
SBENG216 +
DOUBLE DELTA PLATE
SP161212 +
MARINE EYES
ME06

3/16"
STAINLESS STEEL
WIRE 1X19

R	Code	Date	Dimensions in: __	Material: __
0			Scale: NONE Gen.Tol.:NONE	Design date 01/03/2000 By BADB
			STANDING RIGGING KIT 0331 BOX 1/1	View
			BENETEAU USA P.O. Drawer 1218 Marion, SC 29571 (803) 423-4201	Part No. 08020175

THIS DOCUMENT IS PROPRIETARY - REPRODUCTION MUST BE AUTHORIZED BY BENETEAU

Headsail Specification and Technical Worksheet

Model Type:	<i>Beneteau 331 U.S.A.</i>								
Sail Type:	<i>Roller Furling Genoa Series 2000</i>								
"I" Dim:	<i>12500</i>	"J" Dim:	<i>3760</i>	Max Hoist:	<i>12209</i>	Area:	<i>31.3sqmt</i>	Rake:	<i>280</i>
Finished Dimensions									
Luff:	<i>12080</i>	Leech:	<i>11555</i>	Foot:	<i>5499</i>	L.P.:	<i>5264 @140%</i>		
Finish Details									
Material Type:	<i>6.08 Challenge</i>			Tack Detail:	<i>Double webbing Loop</i>				
Head Detail:	<i>Double Webbing Loop</i>			Clew Detail:	<i>40mm ext ring with Leather</i>				
Leech Cleat:	<i>241 Alum. Cleat.</i>			Foot Cleat:	<i>2 #1 eyelets at tack</i>				
Foot/Leech:	<i>Single fold, hotknifed 25mm tabling</i>			U.V. Cover:	<i>Yes, Starboard, white</i>				
Foil Tape:	<i>NP#5</i>			Trim Stripes:	<i>2: 3/8" x 2 green</i>				
TT Window:	<i>Yes, 9" window</i>			Tell tails:	<i>3 sets.</i>				
Bag Type:	<i>Drawstring type "B"</i>			Seams:	<i>2 rows blue / V-92</i>				
Furling System:	<i>Ref: Beneteau Drawing: 08029020</i>								
Drawing Information									
Drawing Name:	<i>331-rfg1.doc</i>	Drawn By:	<i>Bob</i>	Date:	<i>02-26-99</i>	Rev:	<i>08081331-r000.doc</i>		
Additional Notes:	<i>Production sail Rev#1: Corrects "I" measurement</i>								

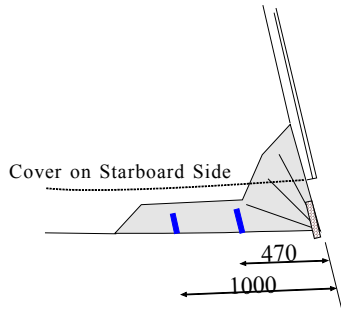

Tack Detail

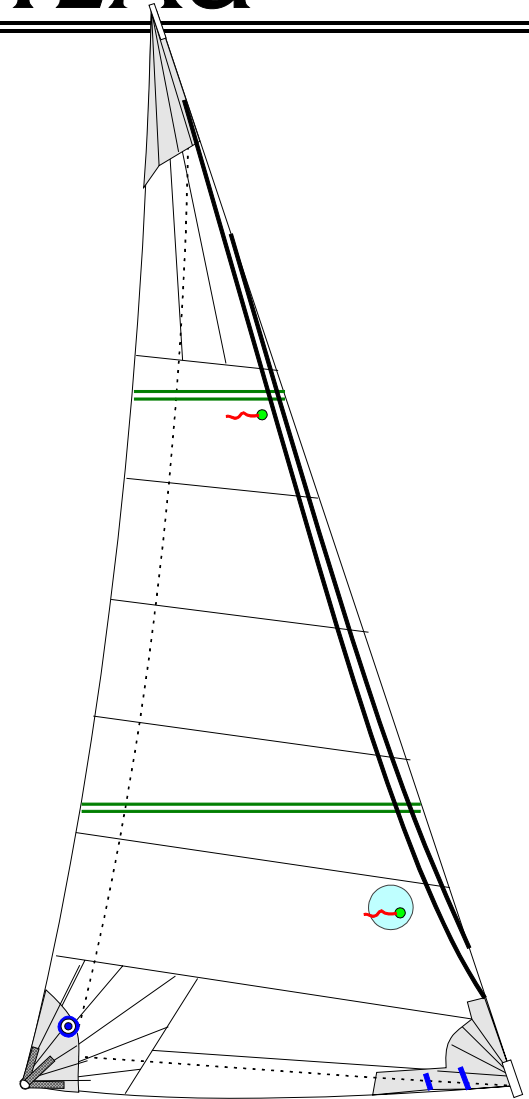

Mainsail Specification and Technical Worksheet

Model Type:	Beneteau 331 U.S.A.						
Sail Type:	Roller Furling Mainsail Series 2000						
"P" Dim:	10400	"E" Dim:	4280	Area:	20.92sqmt	Rake:	280
Finished Dimensions							
Luff:	10296	Leech:	10761	Foot:	4250		
Finish Details							
Material Type:	7.08 Challenge			Tack Detail:	Single ply 25mm webbing loop		
Head Detail:	Single ply 25mm webbing loop			Clew Slug/Car:	3259 Z-spar 60mm clew block		
Clew Detail:	Pg 38 safety clew ring with webbing			Luff tape:	NPS#6 Foil Tape		
Leech/foot:	25mm double tabling			Tell Tale:	Yes, 3 at leech		
Trim stripes:	Yes, 3/8" by 2 in green						
Leech Cleat:	241 Alum cleat			Bag Type:	Drawstring type "B"		
Seam:	V-92 Blue- 2 rows 3-step			U.V. Cover:	Yes, clew only, both sides. White UV		
Mast Section:	Z-Spar : Z500E			Boom Section	Z-Spar: Z360E		
Tack and Clew Cutback Details:							
A:	B:	C:	D:	E:	F:	G:	
Drawing Information							
Drawn By:	Bob	Date:	11-10-99	Revision #	08071331-r002.DOC		
Additional Notes:	Finished Dimensions include head and tack webbs.						

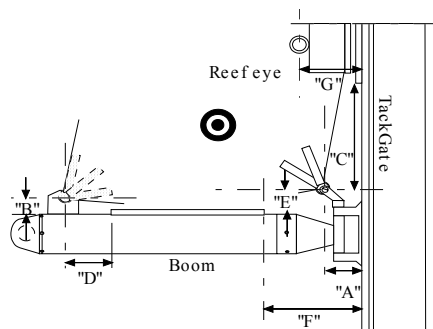
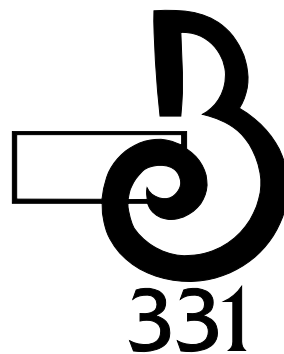
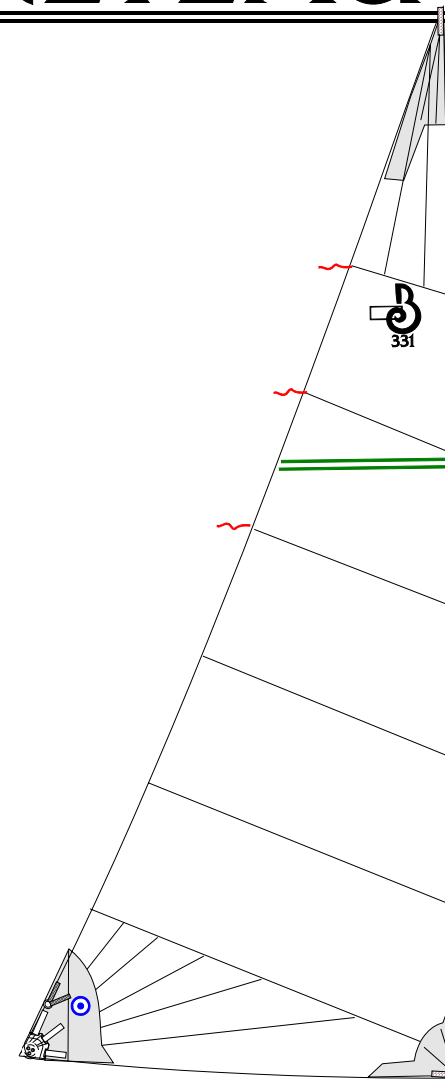

Tack/Clew Detail

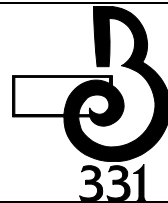
Black

Mainsail Specification and Technical Worksheet													
Model Type:		Oceanis 331 U.S.A.											
Sail Type:		Classic Mainsail Series 2000											
"P" Dim:	10540	"E" Dim:	4350	Rake:	280	Area:	25.1 sqmt						
Finished Dimensions													
Luff:	10390	Leech:	11130				Foot:	4330					
Finish Details													
Material Type:	7.3 Challenge Dacron			Tack Detail:	40mm SS Ring with leather								
Head Detail:	50mm S.S Ring with leather			Clew Slug/Car:	SLD 151								
Head Slide:	Metal Seldon 661B			Clew Detail:	50mm SS ring with leather								
Clew Reef 1:	34118 Wichard block on starboard Side led through PG 23 ring			Tack Reef 1:	33118 Wichard block on starboard Side led through PG 20 ring								
Clew Reef 2:	34118 Wichard block on starboard Side led through PG 23 ring			Tack Reef 2:	34118 Wichard blocs on starboard Side led through PG 20 ring								
Logos	2 bullseyes												
Battens:	4 x 30mm flat												
Bat. Lengths:	#1	770	#2	1500	#3	2200	#4	3000	#5	n.a.			
Trim stripes:	2 x 3/8" green stripes												
Leech Cleat:	241 Alum. With snubbing eyes												
Luff Tape:	4" with 8mm rope												
Leech Line:	4mm Dacron line												
Reef Cleat:	2 x 241 Alum.												
Reef Hts. %	Reef 1	14.5%	Area:	19.28	Reef 2	33.5%	Area:	12.56					
Luff Slides:	15- 661A Seldon slides												
Reefing slots:	None												
Mast Section:	Z-Spar: Z 501				Boom Section:	Z-Spar: Z 360							
Tack and Clew Cutback Details:													
A:	50	B:	000	C:	280	D:	000	E:	25	F:	280	G:	85
Drawing Information													
Drawing	331-clm1			Drawn By:	Bob		Date:	6-6--01		Rev:	08071332-R001.doc		
Additional Notes:	Production Model Classic Main Rev 1: Reduces roach amount to help clear dual backstays												

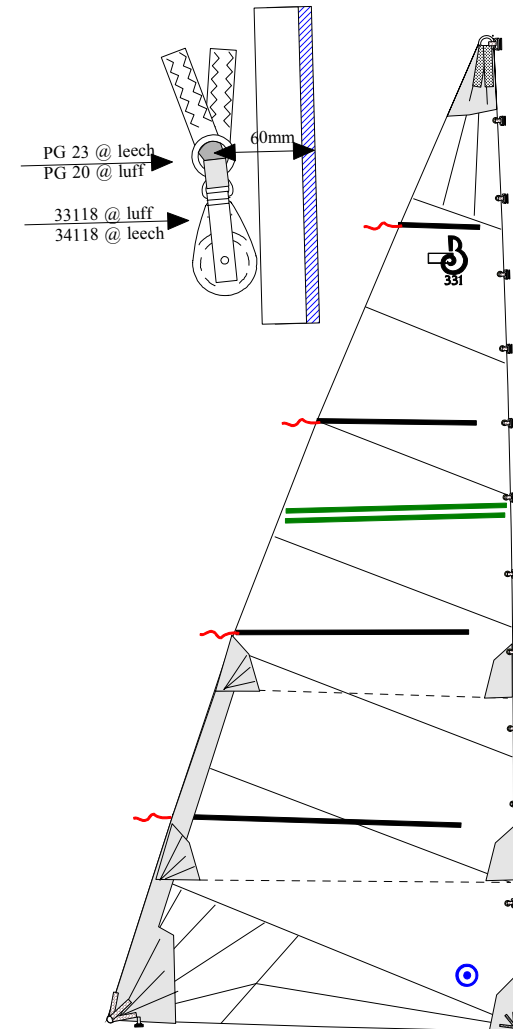

Tack/Clew Detail

Insignia Detail in Black



Beneteau Part #: 0807-1332



Beneteau 331 Classic Cover

Notes:

Cover: Dark Green Odyssey

1. Top section folded over to accept a 11mm round batten.
2. Top sewn to seam. See detail
3. Openings for line notched in as shown.
4. Front flaps to fold inside bag while sailing. It is secured with small Velcro tab to keep them tidy in the interior of bag
5. Web loops and buckle at fore and aft ends for tensioning. ***these should be sewn on the inside of the bag
6. aft end of batten pockets (both sides) sewn closed
7. Front end of batten pockets with velcro on both sides of inside pocket for seal.

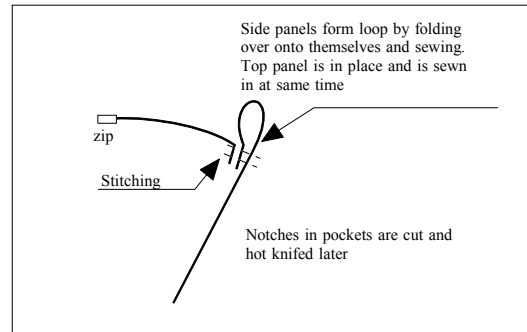

Zipper half to both sides and sewn to front
Fore/aft zip runs from aft forward

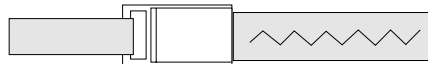
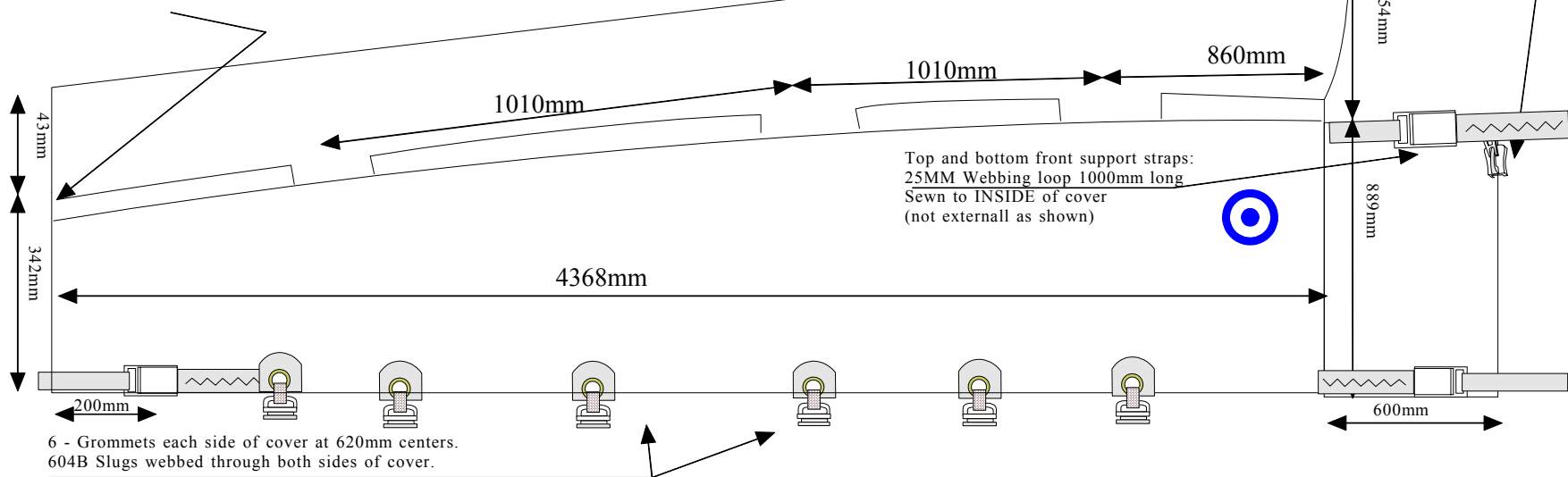

BACK BUCKLE and loop 25mm x 500mm
Loop goes through corner rings and back to other side of bag to allow for tensioning. Buckle should be set 200mm in from ends of bag

The buckle and web are sewn to the INSIDE OF the cover

Neil Pryde Sales & Design Office			
354 Woodmont Rd #18			
Milford Conn. 06460 U.S.A.			
Phone: 203-874-6984 Fax: 203-877-7014			
Drawing Name:		Beneteau 331 Lazy Bag	
Date:	1-19-00	Scale:	Not to Scale
Drawn by:		Bob Pattison	
Revision #:	2	File Name:	



Material List for BOTH SIDES
 4- 30mm rings
 44mts of 6mm line
 Lines will be tied around round batten
 stock that is exposed in cutouts

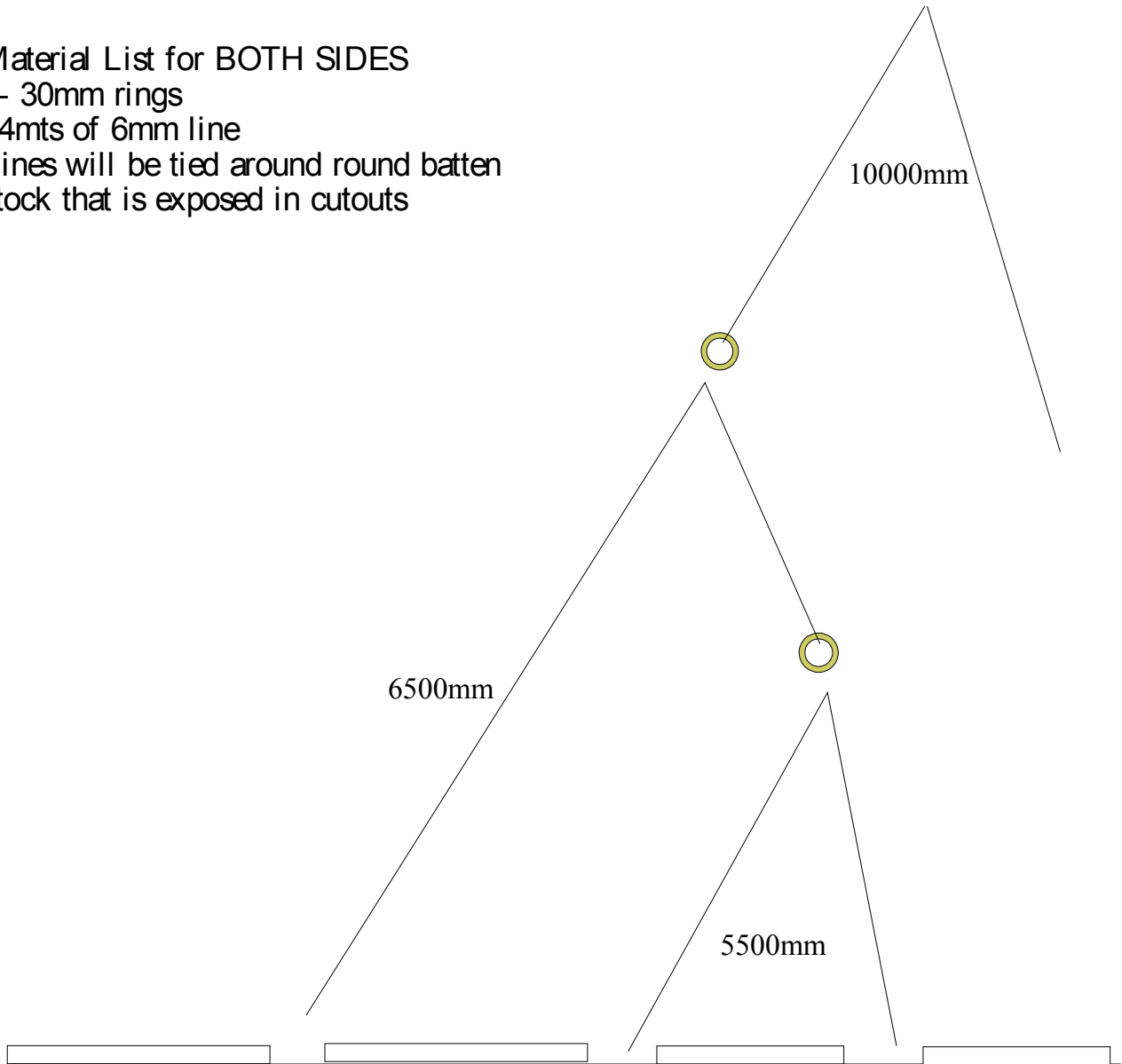

Neil Pryde Sales & Design Office			
50 Broad Street, Milford Conn. 06460 U.S.A. Phone: 203-874-6984 Fax: 203-877-7014			
Drawing Name:		Lazy Jack lines	
Date:	7-15-96	Scale:	Not to Scale
Drawn by:		Bob Pattison	
Revision #:	1-A	File Name:	b382line.ged

DECK LAYOUT FOR ROLLER FURLING MAST (STANDARD) + OPTIONAL GENNEKER

REF	STANDARD MAST	OPTIONAL GENNEKER
1		Foreguy
2		Spinnaker/Whisker pole topping lift
3		Spinnaker/Genneker Halyard
4	Mainsheet	
5	RF Main Outhaul	
6	RF Main Inhaul	
7	Main Halyard	

Genoa Halyard on starboard side of the mast, made off with clamcleat, stowed on a general-purpose cleat.
 Main Boom Topping Lift on a general-purpose cleat.
 Vang cleated on solid vang

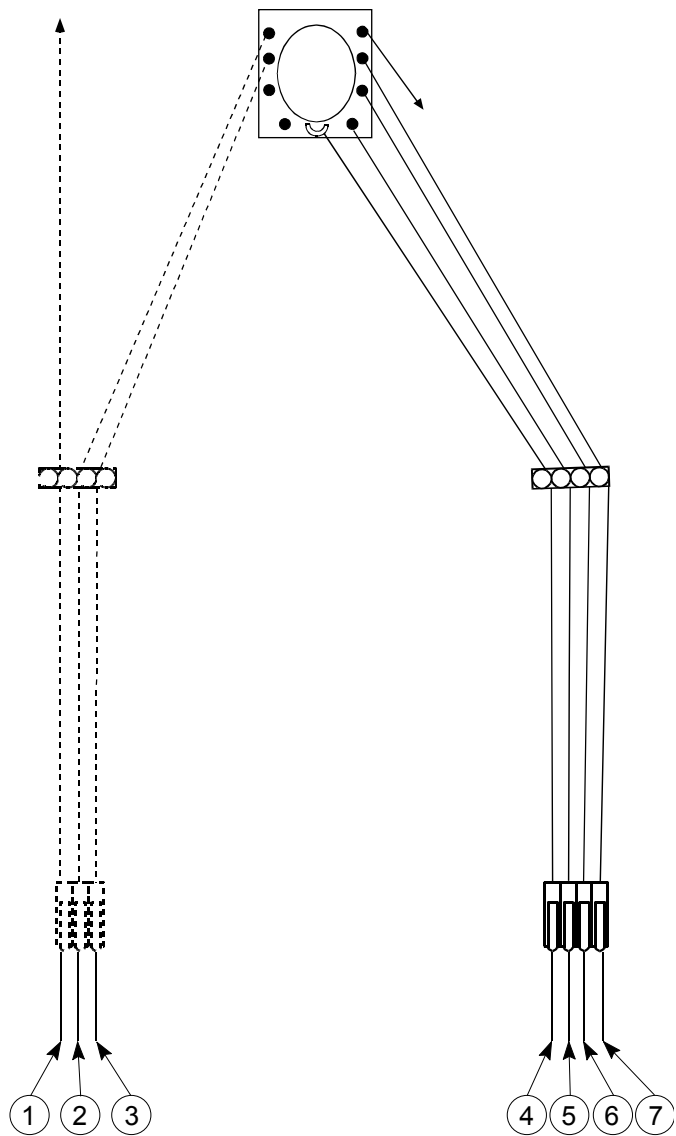

DECK LAYOUT FOR CLASSIC MAST (OPTION) + OPTIONAL GENNEKER

REF	STANDARD MAST	OPTIONAL GENNEKER
1		Foreguy
2		Spinnaker/Whisker pole topping lift
3		Spinnaker/Genneker Halyard
4	Mainsheet	
5	Reef 1	
6	Reef 2	
7	Main Halyard	

Genoa Halyard on starboard side of the mast, made off with clamcleat, stowed on a general-purpose cleat.
Main Boom Topping Lift on a general-purpose cleat.
Vang cleated on solid vang
Outhaul cleated on boom

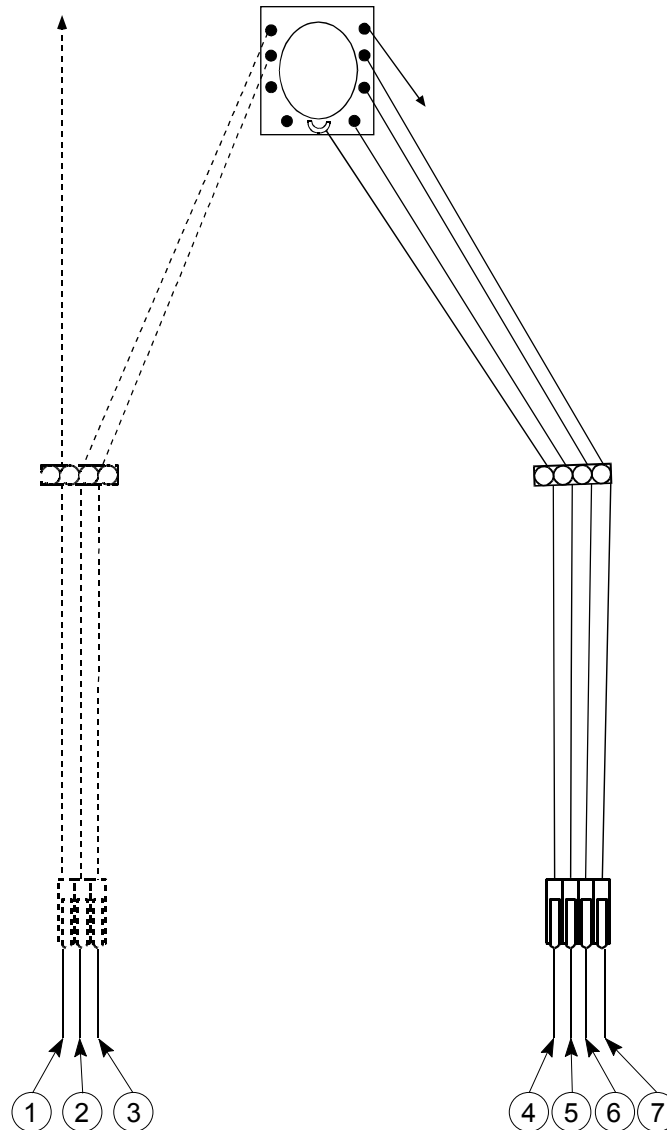

MAINSAIL TACKLE AND REEFING SYSTEM

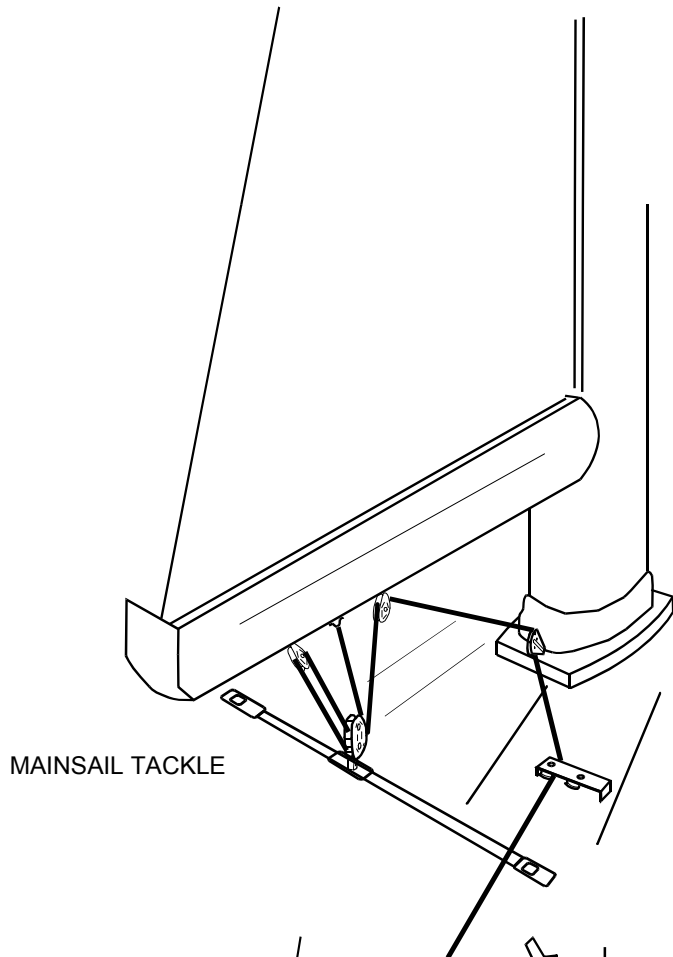

REEFING LINE CIRCUIT

- Reef n°1
- Reef n°2

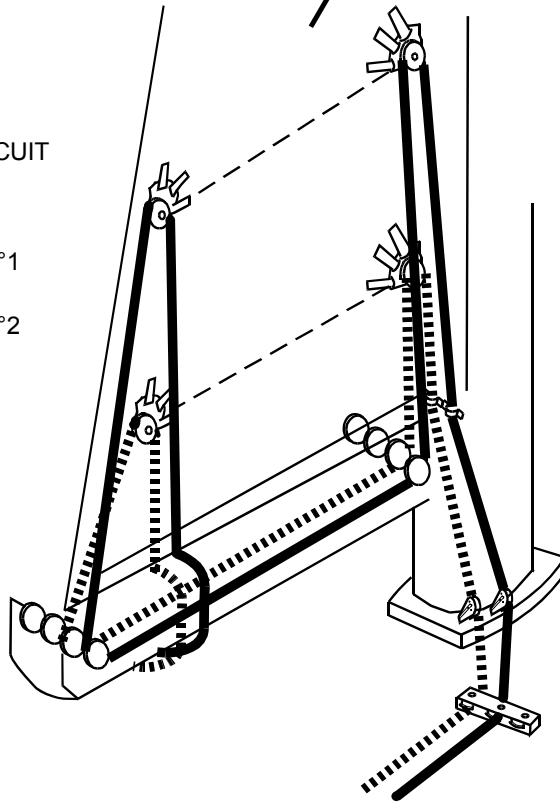

XIV) FRESH WATER SYSTEM

REF	DESCRIPTION
1	Water Tank 170 L (45 US gal)
4	Deck Fill – Fresh Water Tank
5	Vent – Fresh Water Tank
6	Fresh Water Distribution Manifold
7	Fresh Water Filter
8	Fresh Water Pump
10	Water Heater [capacity : 22.7 L (6 US gal)]
13	Galley Sink
14	Washbasin/Shower
15	Icebox
16	Supply for Transom Shower

The fresh water system supplies the sink in the galley, the wash basin and shower in the head, and the transom shower. This system is pressurized by an electric pump. Between the water tank and the pump is a filter. It is necessary to check and clean this filter regularly.

Never run an electric pump when the tank is empty. It may burn out the pump.

To prevent any over pressure in the system during filling, never force the filling nozzle deep down the filler pipe and keep an eye on the vent hole(s) through which the excess water will be discharged.

When the system has not been used for a long period of time, the tanks and pipes should be cleansed with an acetic acid solution (white vinegar).

The water drains out from the sink and wash basins through their own thru-hulls. Close them when the water system is not used.

LAY OUT OF THE FRESH WATER SYSTEM

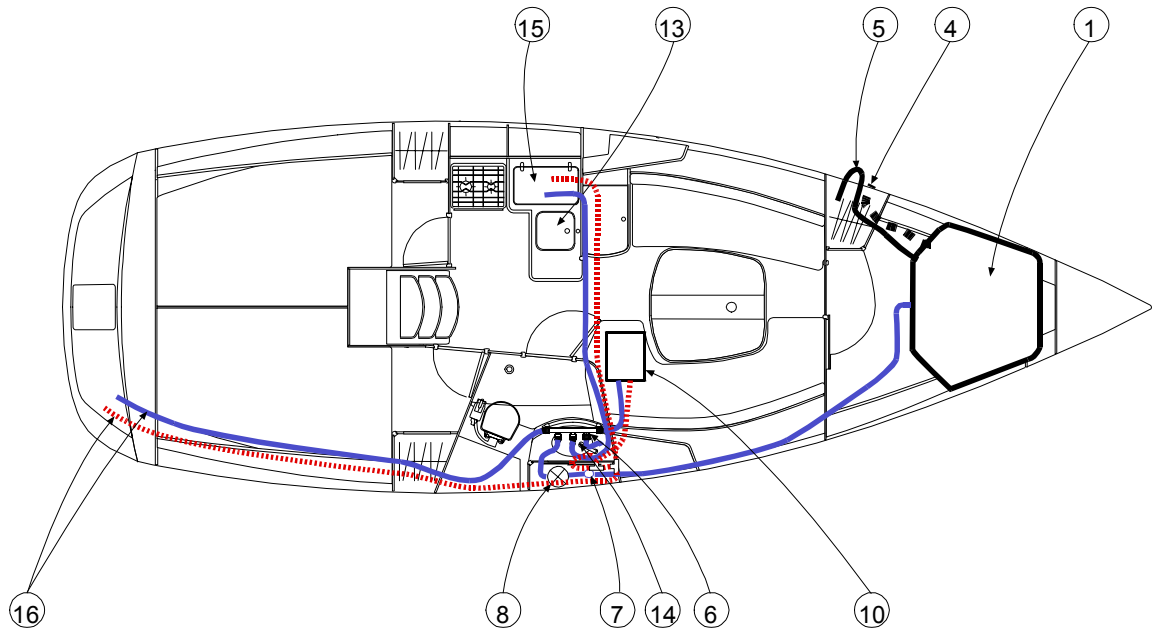
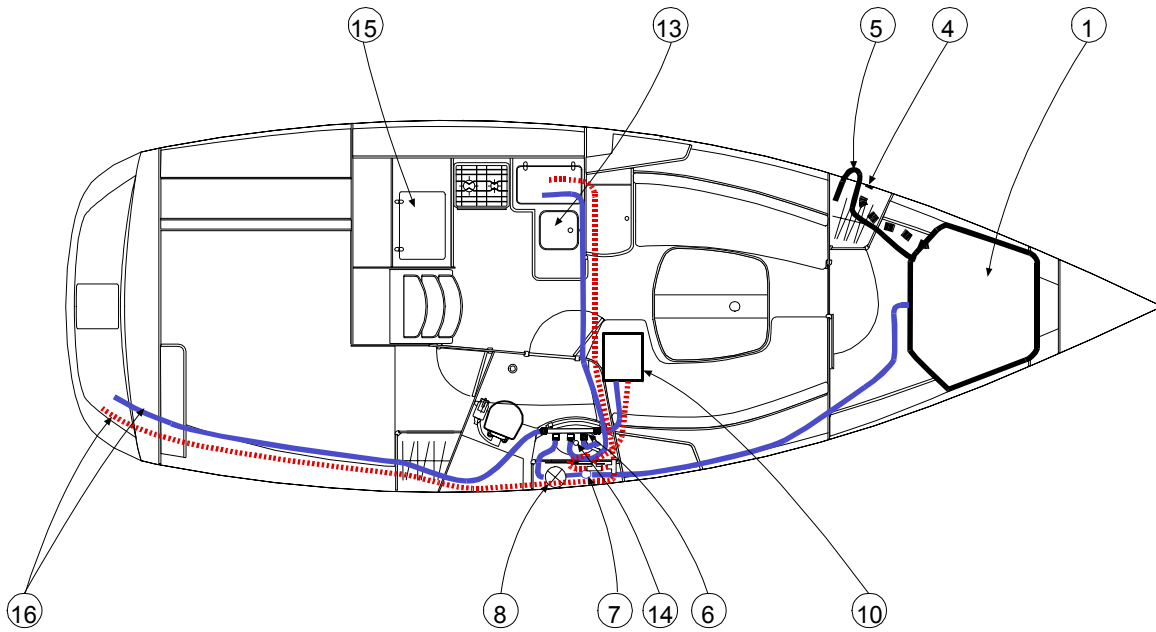

Under Sink in Head

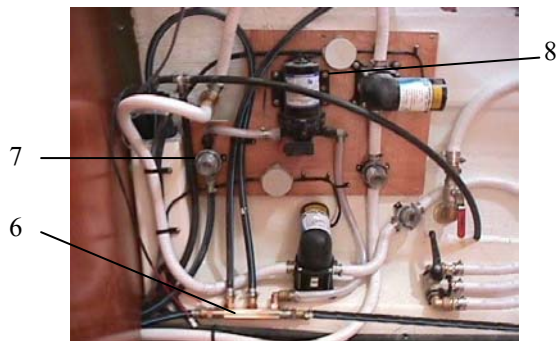

XV) BILGE PUMP SYSTEM

REF	DESCRIPTION
1	Electric Bilge Pump 720 lph (168 gph)
2	Filter of the Electric Bilge Pump
3	Sump
4	Manual Bilge Pump 0.7 l. (.18 US gal.) per stroke
5	Electric Bilge Pump Intake Hose
6	Manual Bilge Pump Intake Hose
7	Electric Bilge Pump Discharge Hose
8	Manual Bilge Pump Discharge Hose
9	Electric Pump for Shower & Icebox Drain
10	Filter for Shower/Icebox Drain Pump
11	Icebox Drain Hose
12	Shower Drain Hose
13	Icebox/Shower Discharge Hose

Make sure the bilge pump system is in good working order before you put out to sea.

Acquaint yourself with the way the bilge pump system of your boat works:

- **Locate the manual bilge pump and the handle.**
- **Locate the on switch of the electric bilge pump and get to know how the seacocks work (for the boats fitted with an electric bilge pump).**

(See the lay out drawing of the system - next page)

Make sure that the bilge pump intake strainer is not blocked with dirt.

Regularly clean the intake strainer on the sump and the filter of the system.

LAY OUT OF THE BILGE PUMP SYSTEM

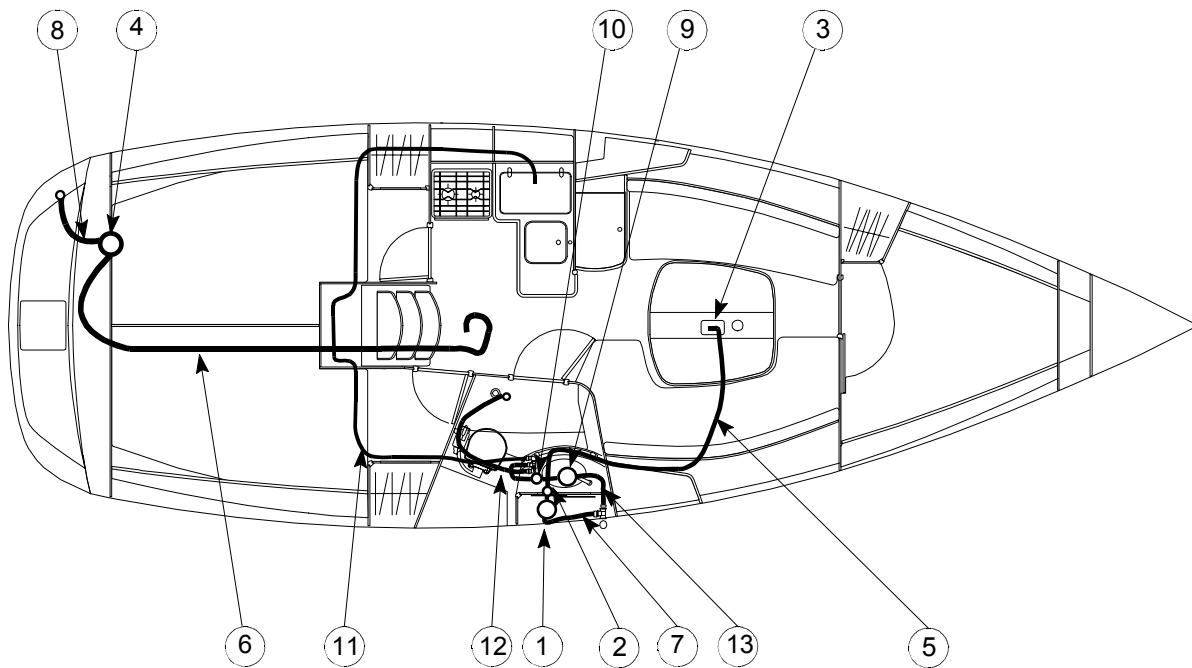
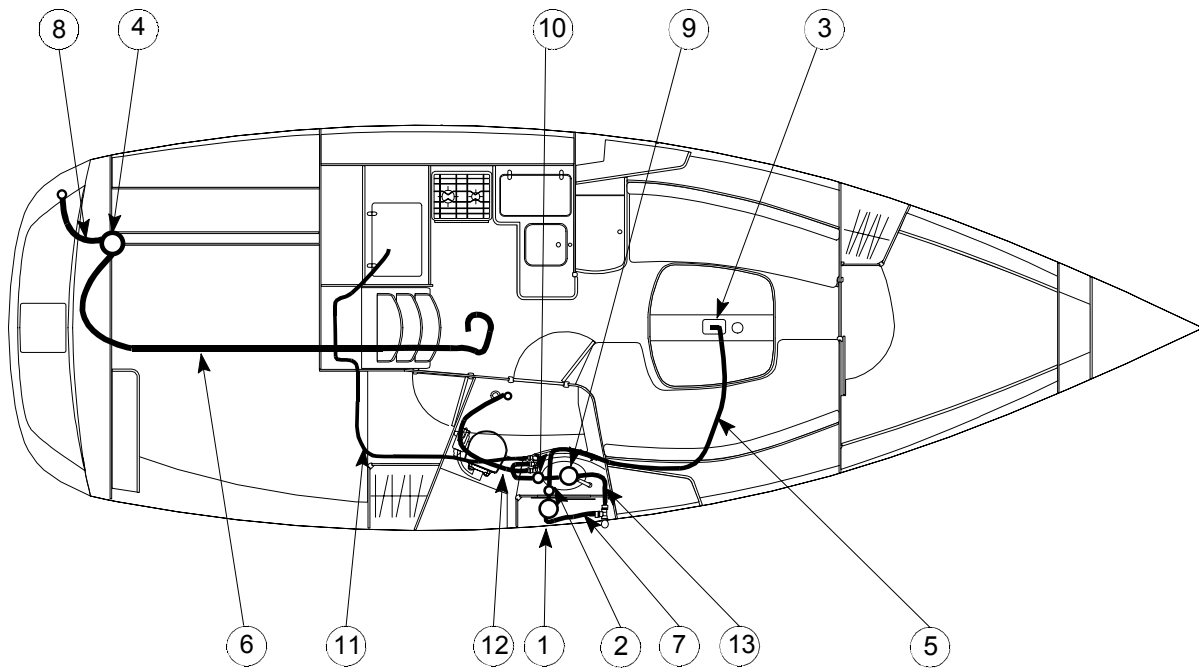

Under Sink in Head

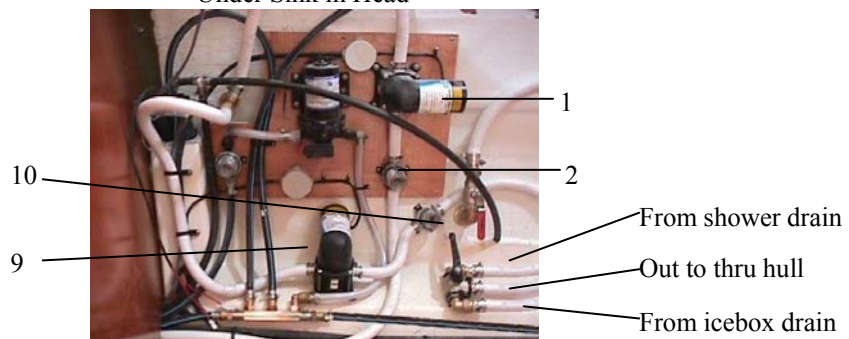

XVI) SEACOCKS AND THRU-HULLS

Close all the seacocks when you leave the boat.

The toilet is situated below the waterline; get into the habit of systematically closing the seacocks after each use.

Make sure that all seacocks, which are not used, are closed before you put out to sea.

Opening and closing of the seacocks

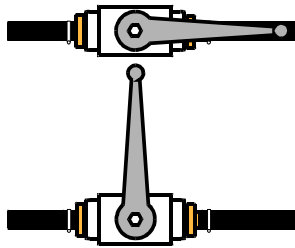

Open

Closed

REF	DESCRIPTION
1	Head Discharge
2	Head Intake
3	Washbasin Discharge
4	Shower/Icebox Discharge
5	Sink Discharge
6	Stern Tube Cooling Intake Valve
8	Engine Cooling Water Intake
9	Speed/Log, Depth Sounder Thruhulls

Operation of three-way valve for toilets

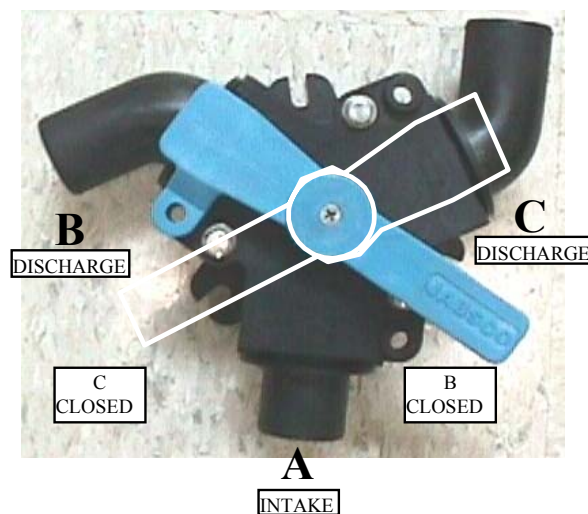

SEACOCK AND THRU-HULL LAY OUT

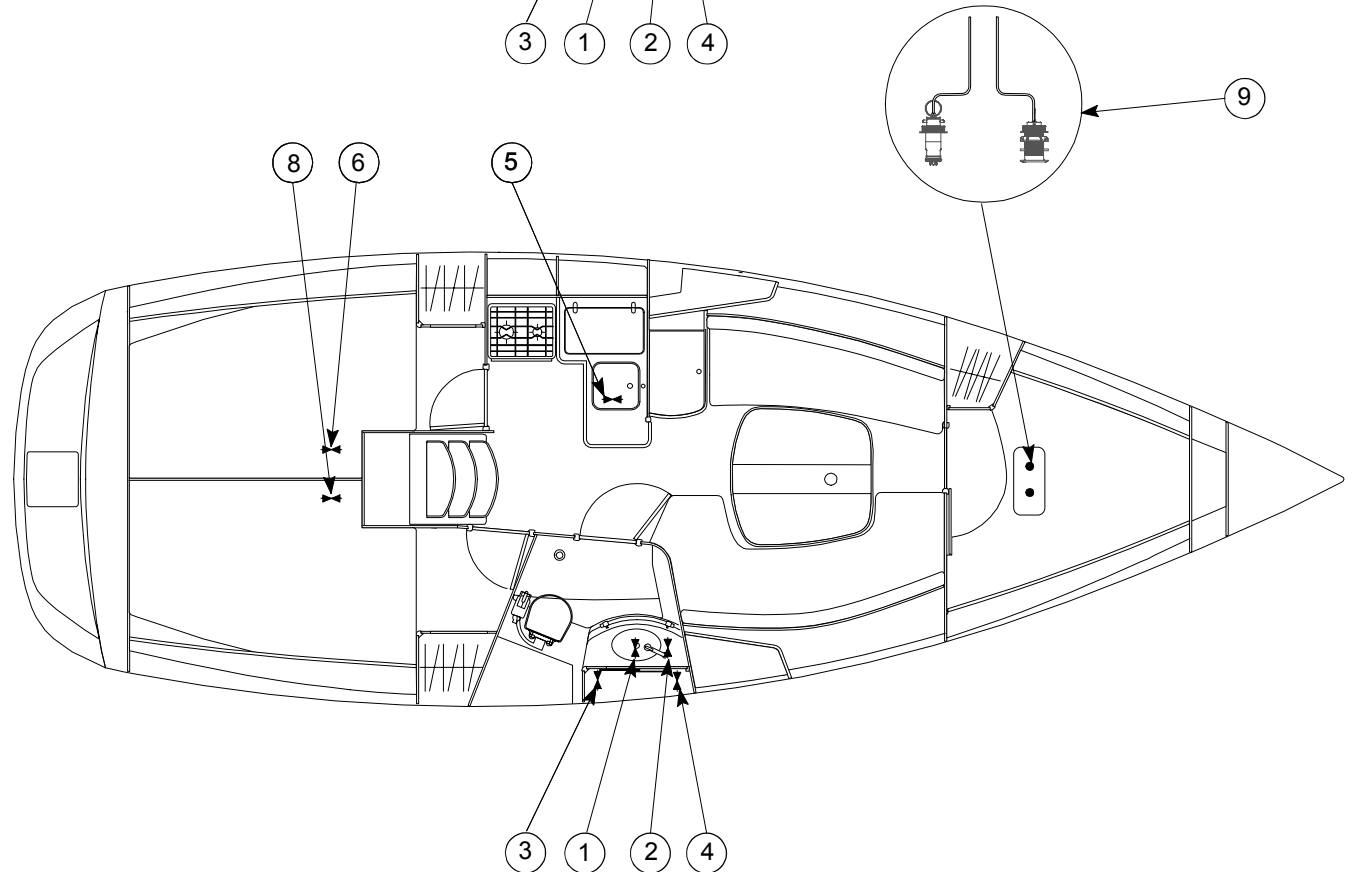
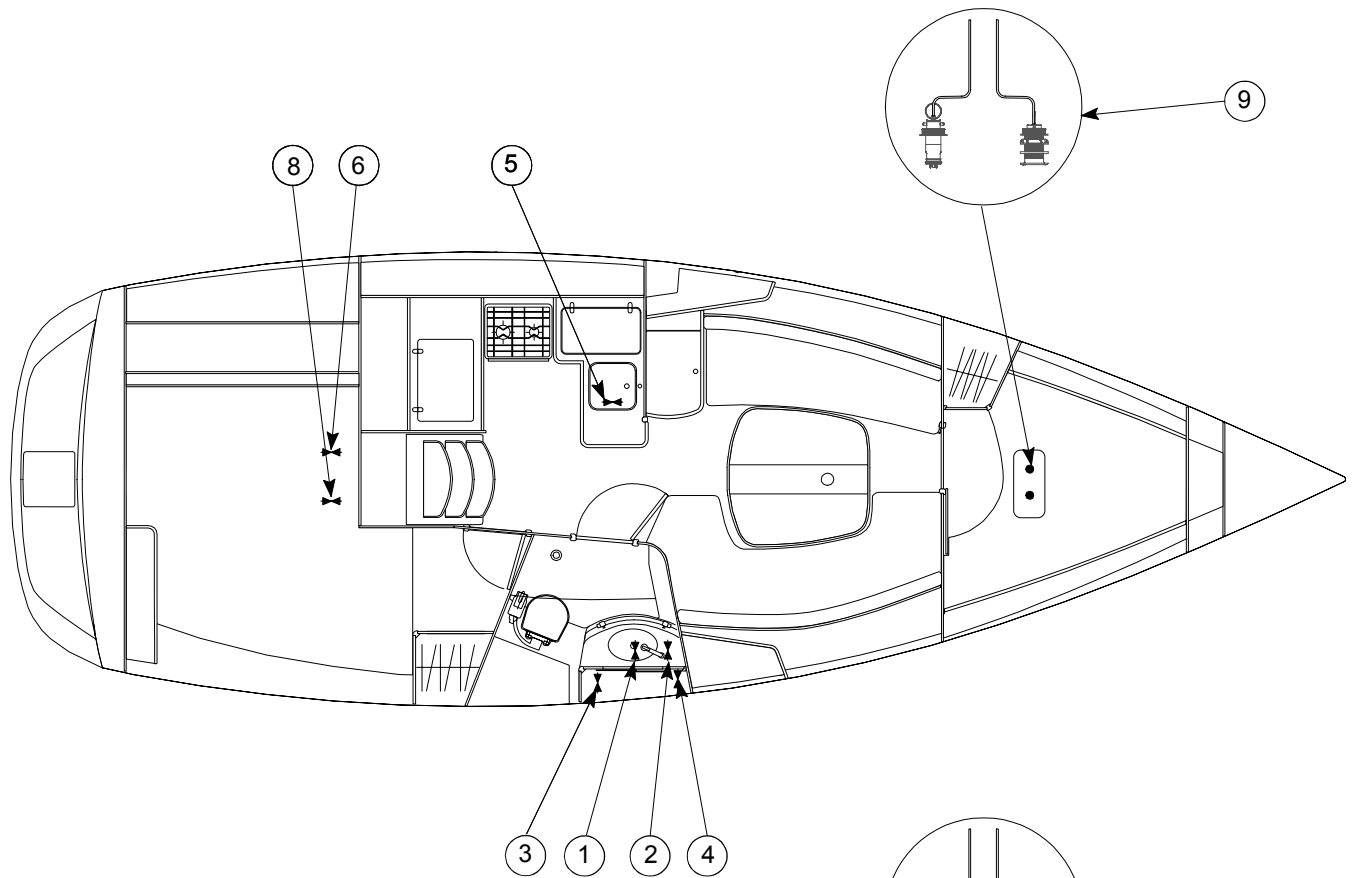

XVII) ELECTRIC SYSTEMS

When the voltage is not specified, all the functions or panels are in 12 Volts.

12V Electric System

Never work on a live electric fitting.

Never tamper with an electric fitting. Call in a technician qualified in marine electricity.

The batteries must be carefully and safely stowed.

In order to prevent a short circuit between the battery terminals, do not store conductive objects near the batteries (e.g. metal tools, ...)

Never alter the specifications of the breakers, which protect against overload.

Never fit or replace the electric materials or appliances with components, which exceed the system amperage.

110V-220V Electric System

Boats are fitted with a 110V/60Hz or a 220V/50Hz system (some as standard, others as an option, depending on the models). We advise you to follow these steps in order to avoid the risk of electric shock and fire.

Do not work on a live fitting.

Connect the boat / shore supply cable to the boat before you plug it into the shore supply socket with the breaker off. Turn the breaker on last.

Do not immerse the boat / shore cable socket.

Turn off the shore supply switch on board before you plug in or unplug the boat / shore supply cable.

Do not tamper with the connections of the Boat / shore supply cable. Use only compatible connections.

ELECTRICITY LAY OUT

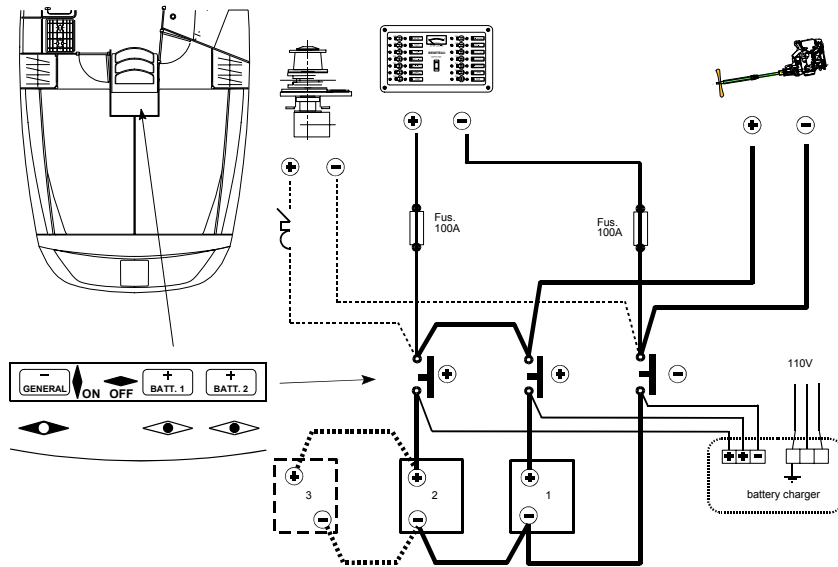
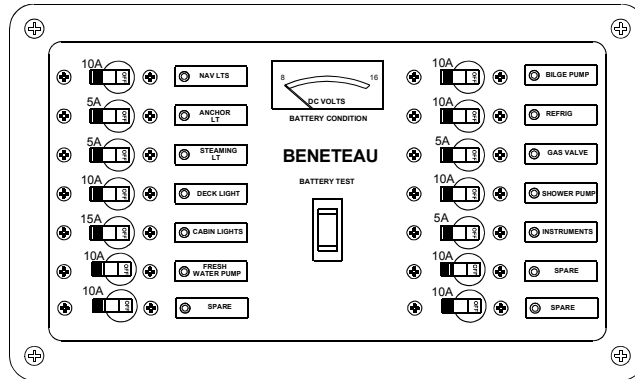

12V PANEL

FUNCTION	BREAKER AMPERAGE (Amp)
Navigation Light	10
Anchor Light	5
Steaming Light	5
Deck Light	10
Cabin Lights	15
Fresh Water Pump	10
Bilge Pump	10
Refrigeration	10
Gas Valve	5
Shower Pump	10
Instruments	5
Spare qty 3	10

110/220V PANEL

FUNCTION	BREAKER AMPERAGE (Amp)
Water Heater	15
Battery Charger	10
Outlets	15

LAY OUT OF THE 12V LIGHTS AND APPLIANCES

REF	DESCRIPTION	FUNCTION ON PANEL
1	Bicolor Bow Navigation Light	Navigation Lights
10	White Stern Navigation Light	Navigation Lights
5	Anchor Light (on mast)	Anchor Light
6	Steaming Light (on mast)	Steaming Light
7	Deck Light	Deck Light
30	Ceiling Light	Cabin Lights
31	Reading Light	Cabin Lights
32	Reading Light	Cabin Lights
33	Reading Light	Cabin Lights
34	Reading Light	Cabin Lights
35	Reading Light	Cabin Lights
36	Reading Light	Cabin Lights
37	Ceiling Light	Cabin Lights
38	Ceiling Light	Cabin Lights
39	Reading Light	Cabin Lights
41	Ceiling Light	Cabin Lights
42	Fluorescent Light	Cabin Lights
43	Ceiling Light	Cabin Lights
44	Ceiling Light	Cabin Lights
45	Ceiling Light	Cabin Lights
46	Fluorescent Light	Cabin Lights
47	Reading Light	Cabin Lights
48	Reading Light	Cabin Lights
49	Reading Light	Cabin Lights
60	Cockpit Lights	Instrument Lights
9	Compass Light	Instrument Lights
13	Fresh Water Pump	Fresh Water Pump
14	Bilge Pump	Bilge Pump
11	Refrigeration	Refrigeration
16	Shower Pump	Shower Pump

12V LIGHT AND APPLIANCE LAY OUT

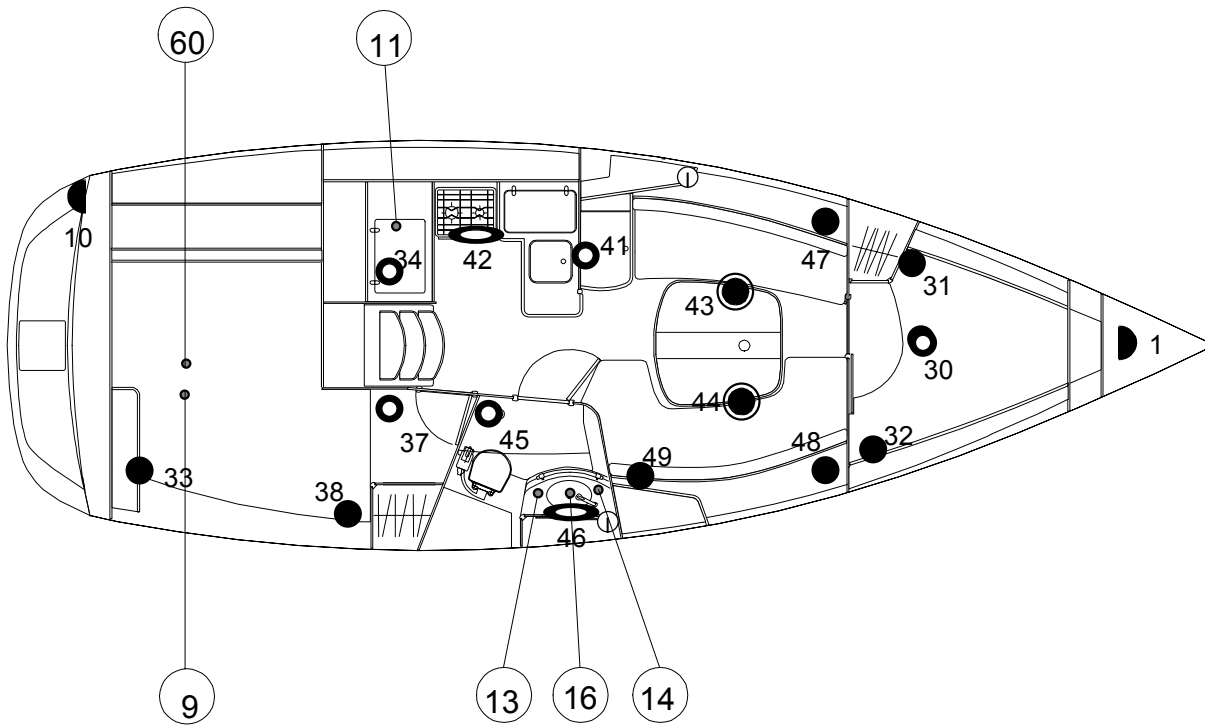

- = CEILING LIGHT WITH SWITCH
- = CEILING LIGHT WITHOUT SWITCH
- = READING LIGHT
- Ⓛ = SWITCH

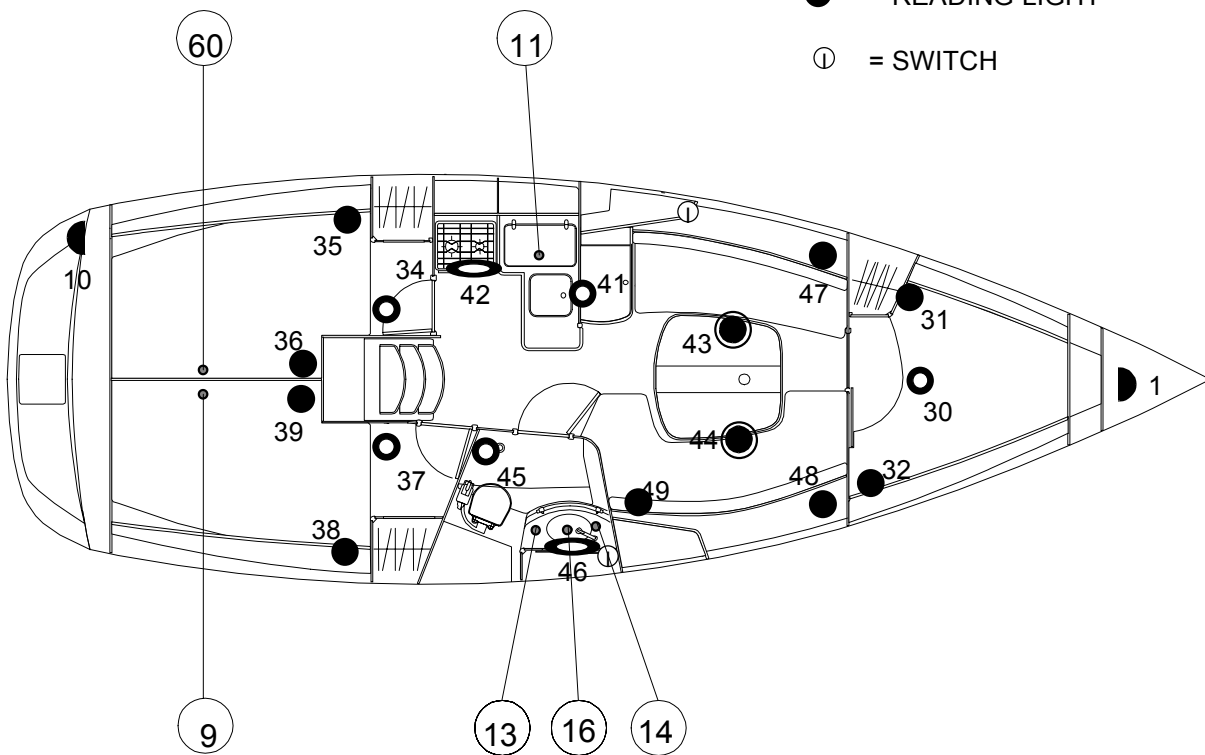

LOCATION OF 110 / 220V SOCKETS AND APPLIANCES

REF	DESCRIPTION
1	Shore Power Inlet
2	Battery Charger
3	110/220V Outlet
4	Water Heater

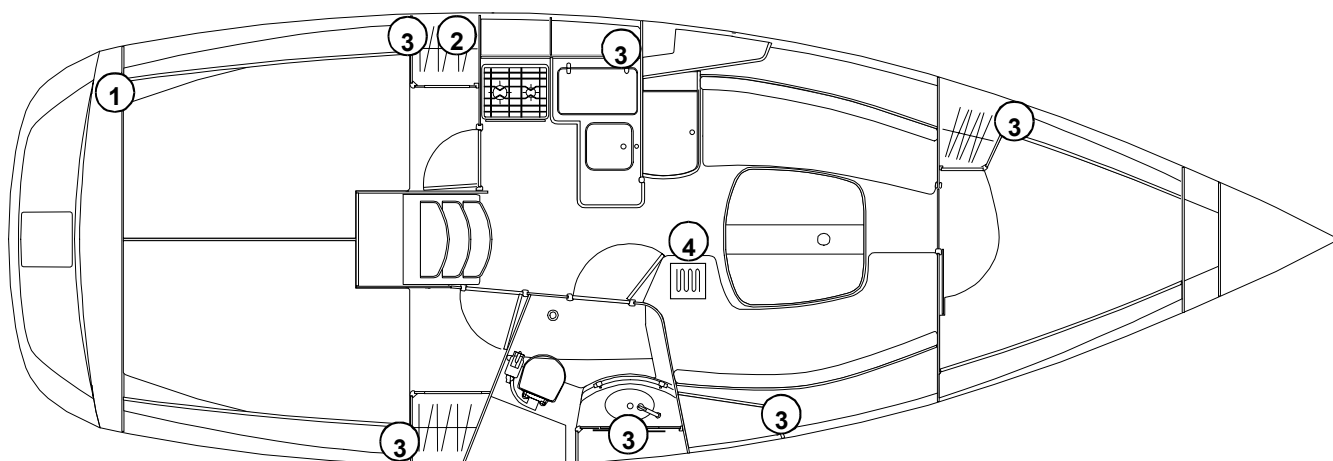
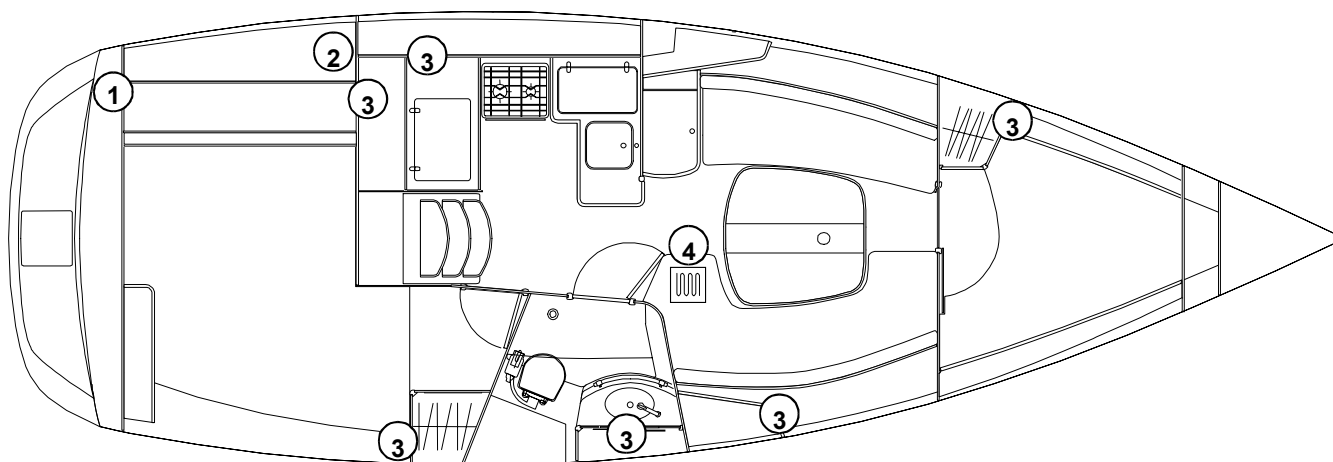

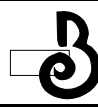

195	16x2	R/B	10.12			Stbd aft cabin fan
33	16x2	R/B	15.92			Stbd aft cabin Aft stbd reading light
38					N° 33 looped	Stbd aft cabin Fwd stbd reading light
37					N° 33 looped	Stbd aft cabin ceiling light
46	16x2	R/B	17.12			Bathroom sink light
45					N° 46 looped	Bathroom ceiling light
41	16x2	R/B			N° 46 looped	Chart table ceiling light
49	16x2	R/B	6.28			Stbd aft salon reading light
48	16x2	R/B	6.18			Stbd fwd salon reading light
193	16x2	R/B	6.38			Fwd stbd salon Fan
272	16x2	R/B	6.48		Not by the panel	Stbd salon speaker
8	14x1	B	3.80			Negative mast
4,5,6,7	16x1	R	3.80			Mast light
44	16x2	R	5.60		+44 , switch looped	Stbd salon ceiling light
		B	4.80			
43					N° 44 looped	Port salon ceiling light
1	16x2	R/B	6.00			Bow light
30	16x2	R/B	5.40			Fwd cabin ceiling light
191	16x2	R/B	4.00			Fwd cabin fan
192	16x2	R/B	3.30			Port Fwd salon Fan
47	16x2	R/B	3.40			Fwd port salon reading light
271	16x2	R/B	3.40		Not by the panel	Port Salon speaker
9	16x2	R/B	8.10			Compass light
98	16x2	R/B	8.10			Instrument
60	16x2	R/B	8.10			Cockpit Light
10	16x2	R/B	9.80			Stern light
274	16x2	R/B	7.05		Not by the panel	STBD Cockpit speaker
39	16x2	R/B	16.95			Stbd aft cabin Fwd port reading light
36					N° 39 looped	Port aft cabin Fwd stbd reading light
42					N° 39 looped	Galley ceiling light
35					N° 39 looped	Port aft cabin port reading light
34					N° 39 looped	Port aft cabin ceiling light
273	16x2	R/B	4.95		Not by the panel	Port Cockpit speaker
194	16x2	R/B	3.35			Port aft cabin fan

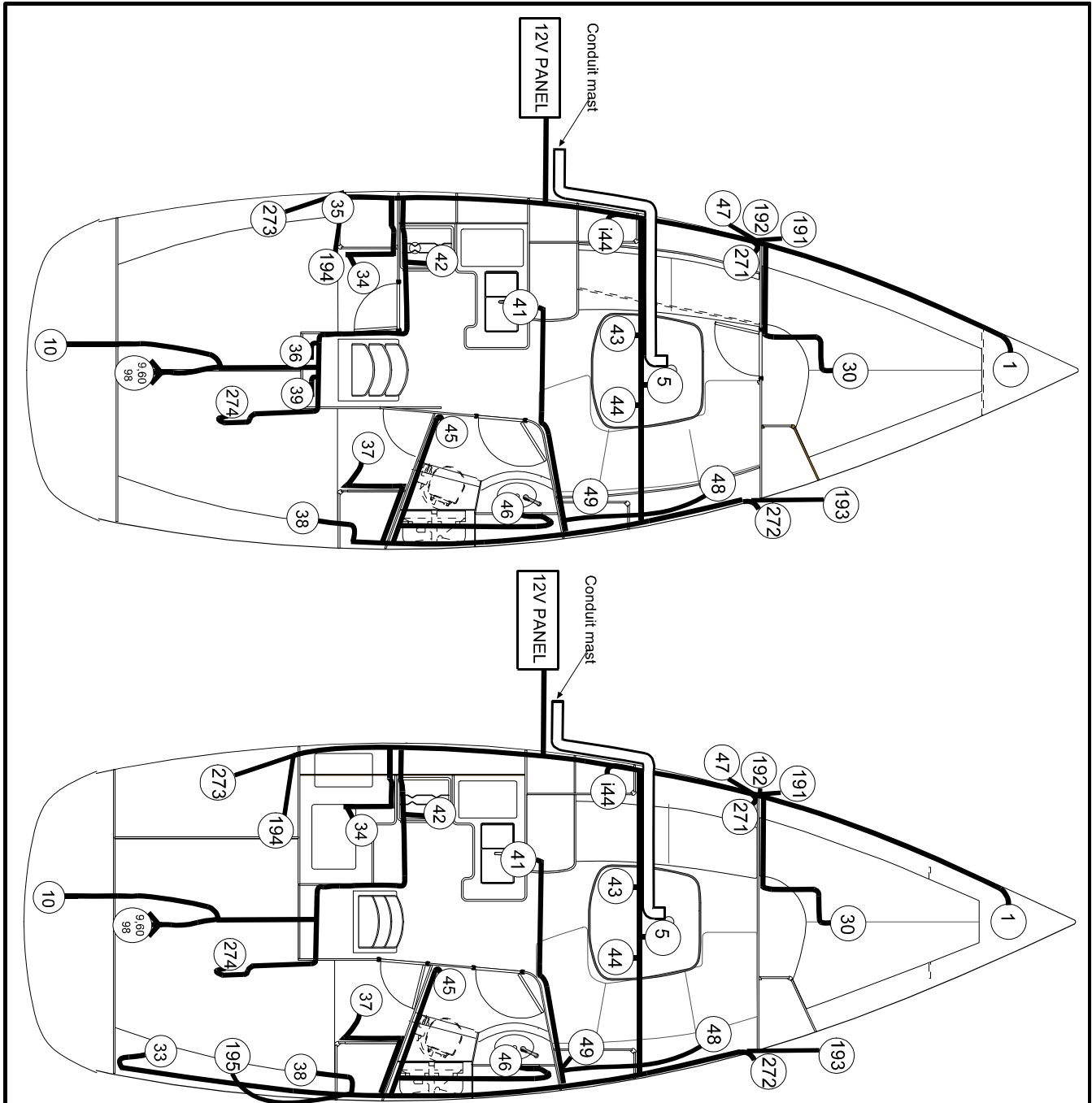
WIRE #	SIZE AWG	COLOR	L . (m)	Code	NOTE	DESIGNATION
R	DESCRIPTION		DATE	DIMENSION:		Material: VISA
	 FH8 DRAWING			TOL GEN :		DATE :9/30/99
				Wire Designation O331 deck harness		BY : P.LG
A	Shorten harness by 1.5m		11/4/99	 BENETEAU USA P.O. Drawer 1218 Marion, SC 29571 (803) 423-4201		Part No: 050886
THIS DOCUMENT IS - PROPRIETARY AND REPRODUCTIONS MUST BE AUTHORIZED BY BENETEAU DRAWN BY BENETEAU - SPECIFIED AND DESIGNED BY PRODUCT MANUFACTURER.						





R	DESCRIPTION	DATE	DIMENSION:	Material:	VISA
			TOL GEN :	DATE :10/1/99	
			O331 Deck harness lay-out	BY : P.LG	
			BENETEAU USA P.O. Drawer 1218 Marion, SC 29571 (803) 423-4201	Part No: FF01	
<small>THIS DOCUMENT IS - PROPRIETARY AND REPRODUCTIONS MUST BE AUTHORIZED BY BENETEAU DRAWN BY BENETEAU - SPECIFIED AND DESIGNED BY PRODUCT MANUFACTURER.</small>					

24	16x2	R/B	3,50		Separate from harness	Fuel gauge
32	16x2	R/B	13.45			FWD Cabin Stbd reading light
14	14x2	R/B	10.75			Bilge pump
131	14x1	R	10.75			Fresh water pump light (MRG's)
13	14x2	R/B	10.75			Fresh water system
16	14x2	R	12.15			Shower pump
		B	10.35			
991	8x1	R	5.40			From battery charger to BSW1+
992	8x2	R/B	5.40			From battery charger to BSW2+and BSW-
145	14x1	R	10.75			Bilge pump alarm
143	14x1	R	16.75			Float switch
142	14x2	R/B	12.75			Submersible bilge pump
144	14x2	R/B	8.05			Constant power for Bilge pump
99	6x2	R/B	8.05			Main 12v
T1	16x1	R	8.15			Engine battery test
17	16x2	R/B	11.15			Propane solenoid
11	10x2	R/B	4.30			Refrigeration
171	16x2	R/B	5,15			LPG light
165	14x1	R	16,35			Ice box drain
97	16x2	R/B	1.70			VHF
27	16x2	R/B	1.70			Stereo
31	16x2	R/B	3,40			FWD Cabin port reading light

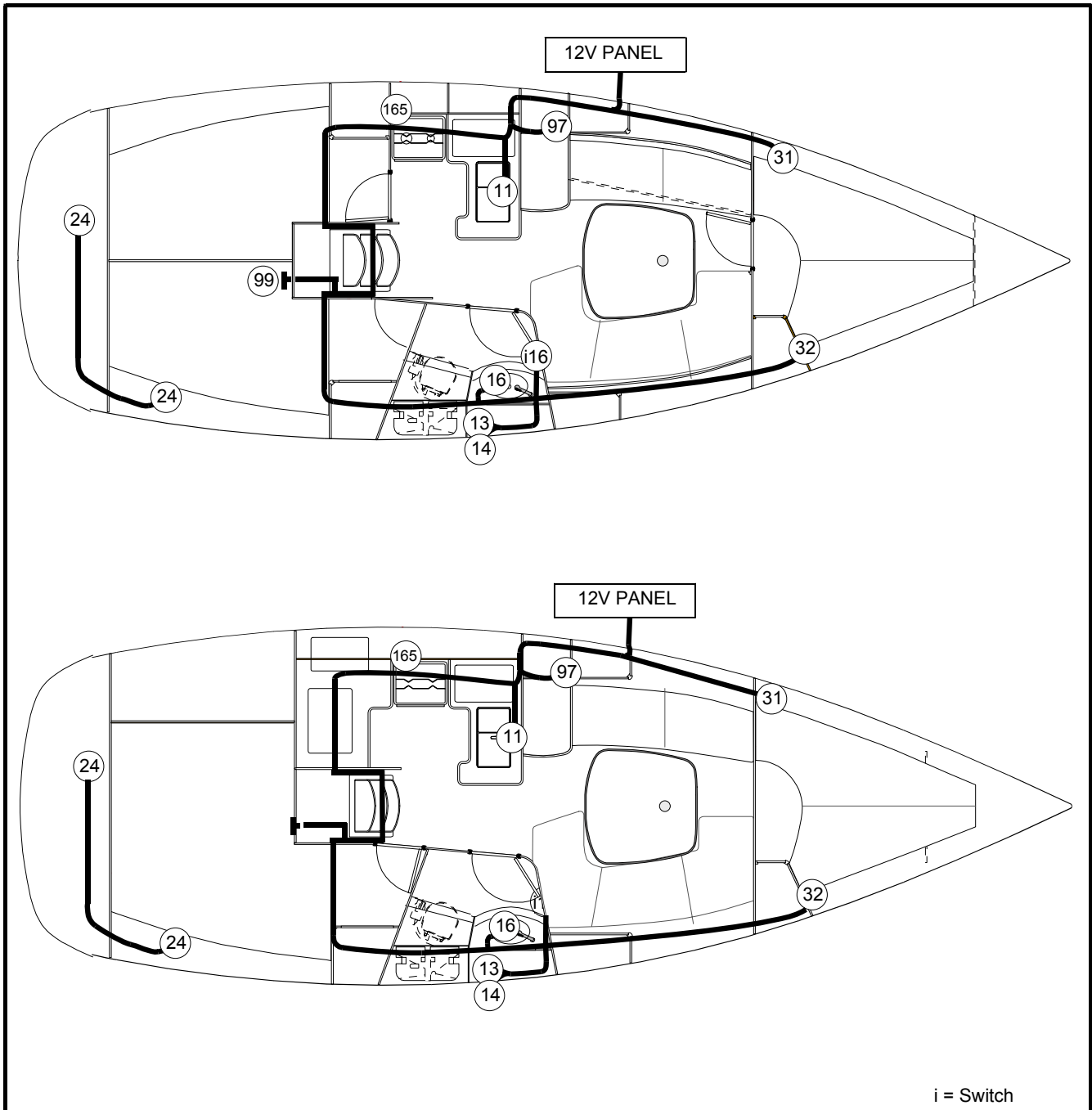
WIRE.#	SIZE AWG	COLOR	L . (m)	Code	NOTE	DESIGNATION	
R	DESCRIPTION		DATE	DIMENSION:		Material:	
	 FH8 DRAWING			TOL GEN :		DATE : 10/1/99	
			 0331 HULL HARNESS Wire designation		BY : P.LG		 Page 2of2
					Part No:		
<small>THIS DOCUMENT IS - PROPRIETARY AND REPRODUCTIONS MUST BE AUTHORIZED BY BENETEAU DRAWN BY BENETEAU - SPECIFIED AND DESIGNED BY PRODUCT MANUFACTURER.</small>							



R	DESCRIPTION	DATE	DIMENSION:	Material:	VISA
	 FH8 DRAWING		TOL GEN :	DATE :10/2/99	
			O331	BY : P.LG	
				Hull harness lay-out	Part No: FF01
			 BENETEAU USA P.O. Drawer 1218 Marion, SC 29571 (803) 423-4201		
<small>THIS DOCUMENT IS - PROPRIETARY AND REPRODUCTIONS MUST BE AUTHORIZED BY BENETEAU DRAWN BY BENETEAU - SPECIFIED AND DESIGNED BY PRODUCT MANUFACTURER.</small>					

LAY OUT OF THE CONDUITS

REF	DESCRIPTION
1	Extra Conduit from Starboard side to Port side
2	Conduit 12V Panel to Transom
3	Conduit from Panel to Mast
4	Conduit From Panel to Fwd Cabin
5	Conduit from Pump House to Galley

————— Passage in the hull liner

..... Passage in the deck liner

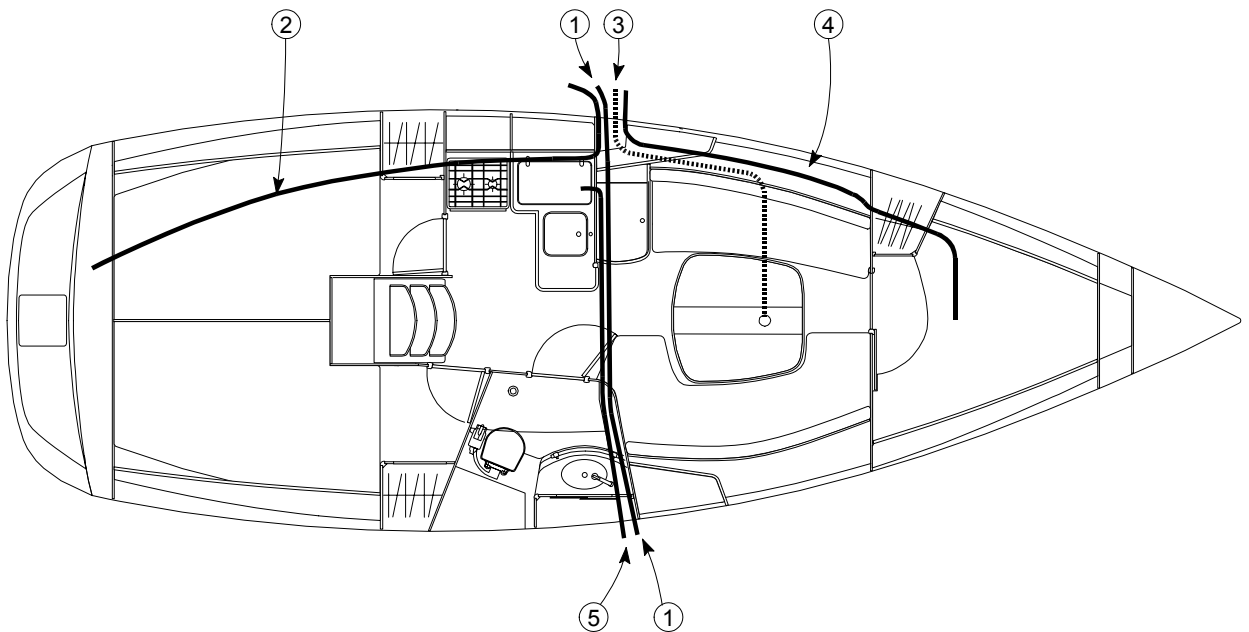
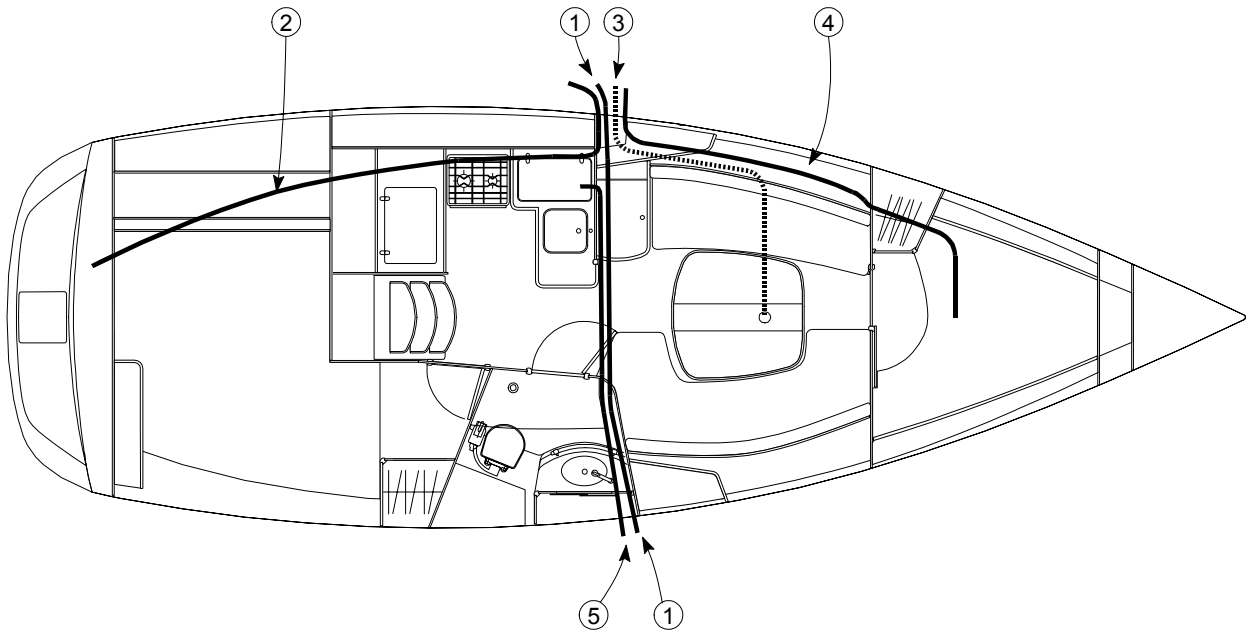

XVIII) LP GAS SYSTEM

Gas Stove

The boat is delivered without a fire extinguisher. It is your responsibility to comply with the laws and regulations of your country (Number, capacity, type and place of fire extinguishers). We advise you to install an extinguisher less than 5 meters away from the center of each berth, less than 2 meters away from the extinguisher aperture in the engine compartment, less than 2 meters away from any open flame device and less than 1 meter away from the helm pedestal or cockpit. We advise a total capacity of the portable extinguishers reaching 8A/64B, each extinguisher having at least a 5A/34B capacity. The CO2 extinguishers shall be used to fight fires in the galley and electric fires.

Do not install or store flammable materials above the stove (Curtains, papers, napkins, etc...)

Never leave the boat unattended when the LP gas appliances are in use.

The appliances, which use fuel, consume the oxygen within the cabin and release combustion products into the boat. It is necessary to ventilate the boat when using the gas cooking appliances. Do not obstruct the air vents of the boat.

Do not smoke or use an open flame when you are trying to locate a gas leak, change the gas bottle or work on the gas system.

If you smell gas or find that the burners have gone out by accident, (although appliance models cut off the gas automatically if the flames go out) turn off the gas valves and ventilate the boat in order to get rid of any residual gas. Find the cause of the problem before re-lighting the appliance.

Do not use cooking appliances to heat the inside of the boat.

Make sure that the burner valves are turned off before you turn on the 12V solenoid and the valve on the cylinder.

Turn off the 12V solenoid and the valve on the cylinder when you do not use the appliances.

Do not obstruct the access to the gas system components, in particular the access to the valves (cylinders and gas cooker).

The flexible hoses, which connect the gas cylinder at one end of the system and the stove at the other end, shall be changed in pursuance of the regulations in force in your country. Only use hoses, which meet the safety standards of your country.

Do not use the gas cylinder storage space to store other equipment.

Pay particular attention to keep in good condition the screw thread of the cylinder on which the regulator is attached. Check the condition of the regulator every year and change it if necessary. Use a regulator identical to the one which is fitted.

Make sure that the valve of the empty cylinder is turned off and disconnected from the system.

Do not use ammonia-based products to clean any part of the system or to discover a leak.

The LP gas system should be checked for leaks on a regular basis. See the manual provided with the stove for instructions.

LAY OUT OF THE GAS SYSTEM

REF	DESCRIPTION
1	Gas Locker
2	Valve and Regulator
3	Gas Locker Ventilation

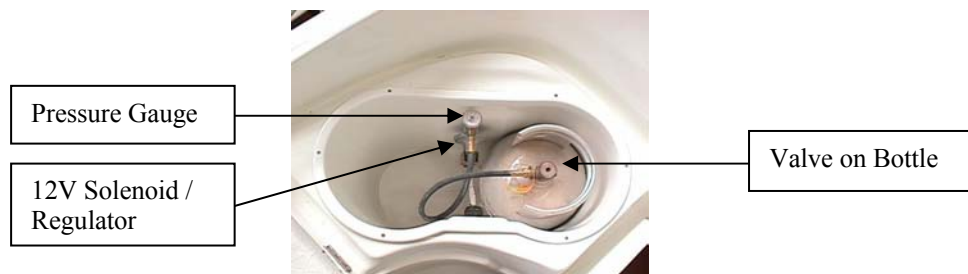
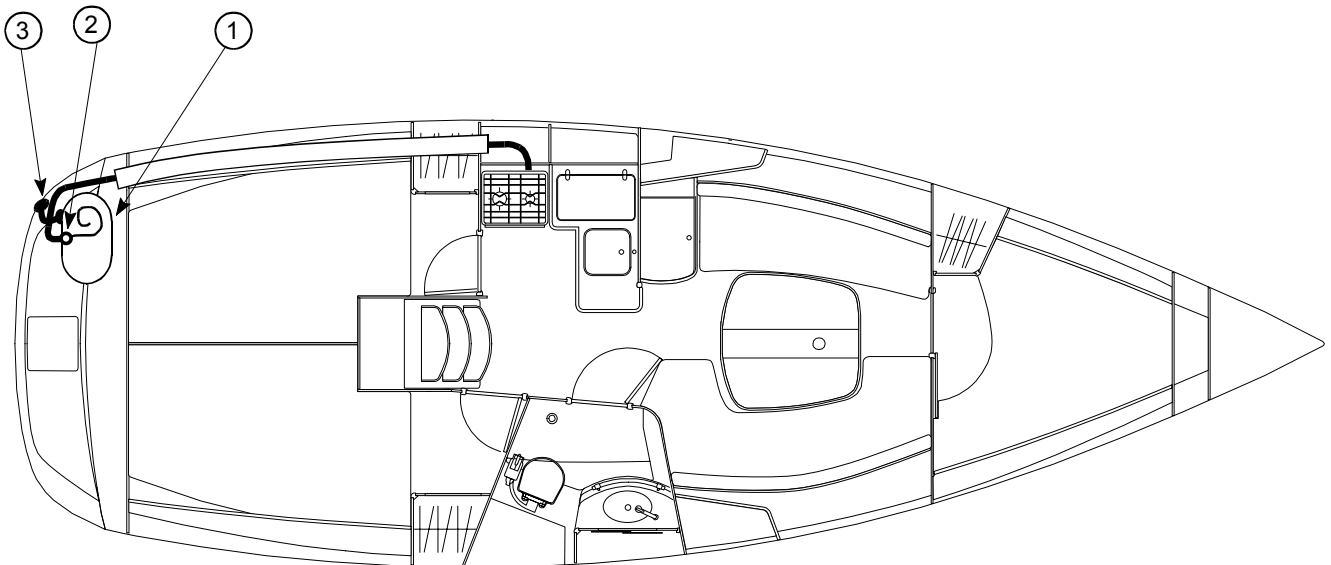
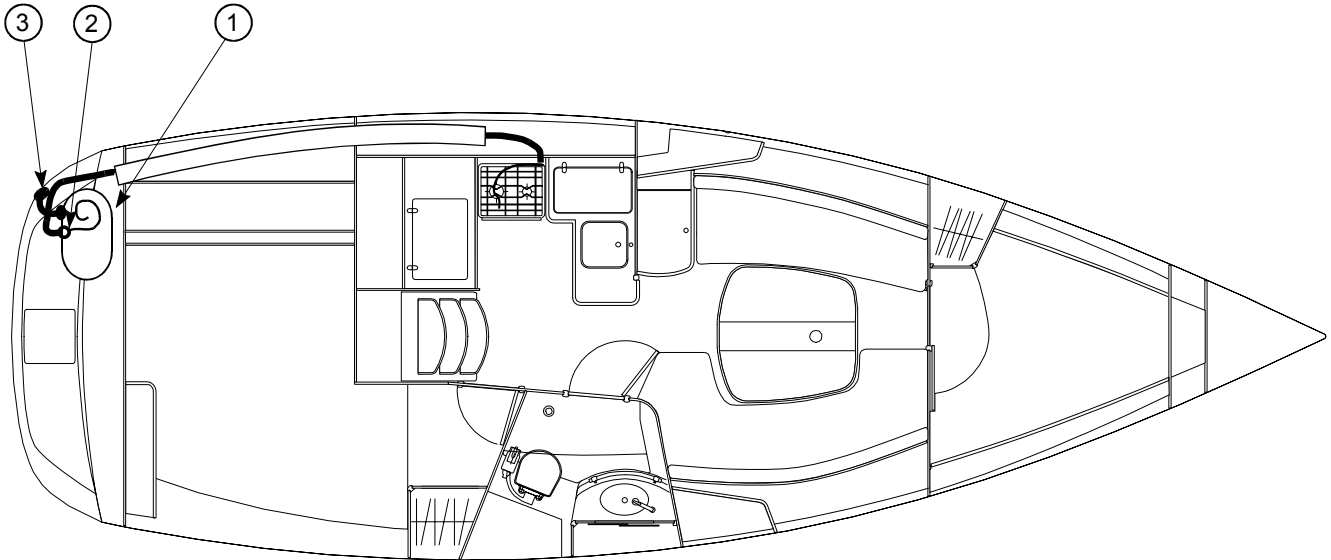

XIX) EMERGENCY STEERING SYSTEM

Your boat is provided with an emergency tiller for use if there is a failure in the wheel steering system. The access cover on the cockpit floor above the rudder must be kept clear at all times.

Check at least once a year that the steering cables are properly tightened and lubricated.

To use the emergency tiller, remove the access cover; insert the tiller into the socket on the rudderstock. You may remove the steering wheel while using the tiller, to improve the tiller handle clearance.

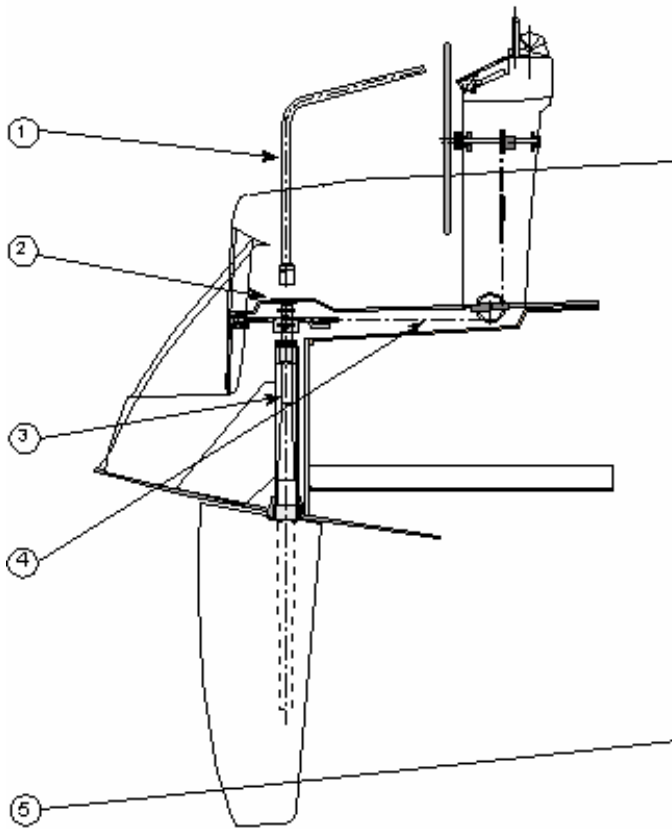

REF	DESCRIPTION
1	Emergency Tiller
2	Cap to Get to the Rudder Stock
3	Rudder Stock
4	Steering Cable
5	Quadrant
6	Rudder Shaft Bearing
7	Split Sleeve – up to hull #30
8	Washer – up to hull #30

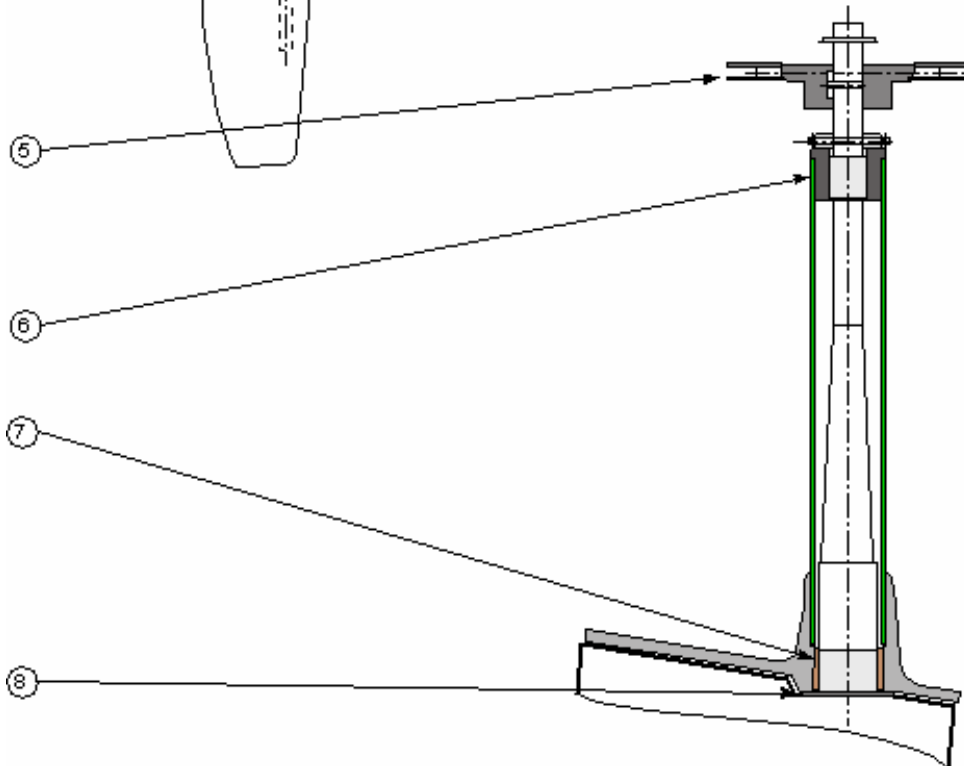

XX) ENGINE

Stop the engine; and do not smoke while you are filling up the fuel tank.

Before you start the engine, make sure that the engine compartment bilge is clean and dry. If there is the slightest presence of fuel in the engine compartment, you must not start the engine.

Fuel that is stored outside the tanks (spare cans, jerrycans) should be kept and stored in a ventilated place.

Know exactly where the fire extinguisher aperture is located so you will be able to put out a fire breaking out in the engine compartment.

REF	DESCRIPTION	REF	DESCRIPTION
1	Engine Ventilation Cowl	16	Propeller
2	Engine Ventilation Hose	17	Exhaust Hose
3	Anti- Siphon Valve	18	Hatch to the Engine
4	Removable Companionway Stair	19	Battery Switches
5	Fire Extinguisher aperture	20	Intake Strainer
6	House Battery	21	Engine Panel
7	Engine	22	Skeg
8	Coupling Plate	23	Exhaust Outlet
9	Muffler	24	Sea Water Filter
10	Engine Water Intake	25	Fuel Filter
11	Engine Control Handle in the Cockpit	26	Engine Stop Control
12	Shaft Seal	27	Fuel Shutoff Control
13	Propeller Shaft	28	Fuel – Deck Fill
14	Fuel Tank	29	Stern Tube Valve
15	Stern Tube	30	Engine Battery

ENGINE LAY OUT

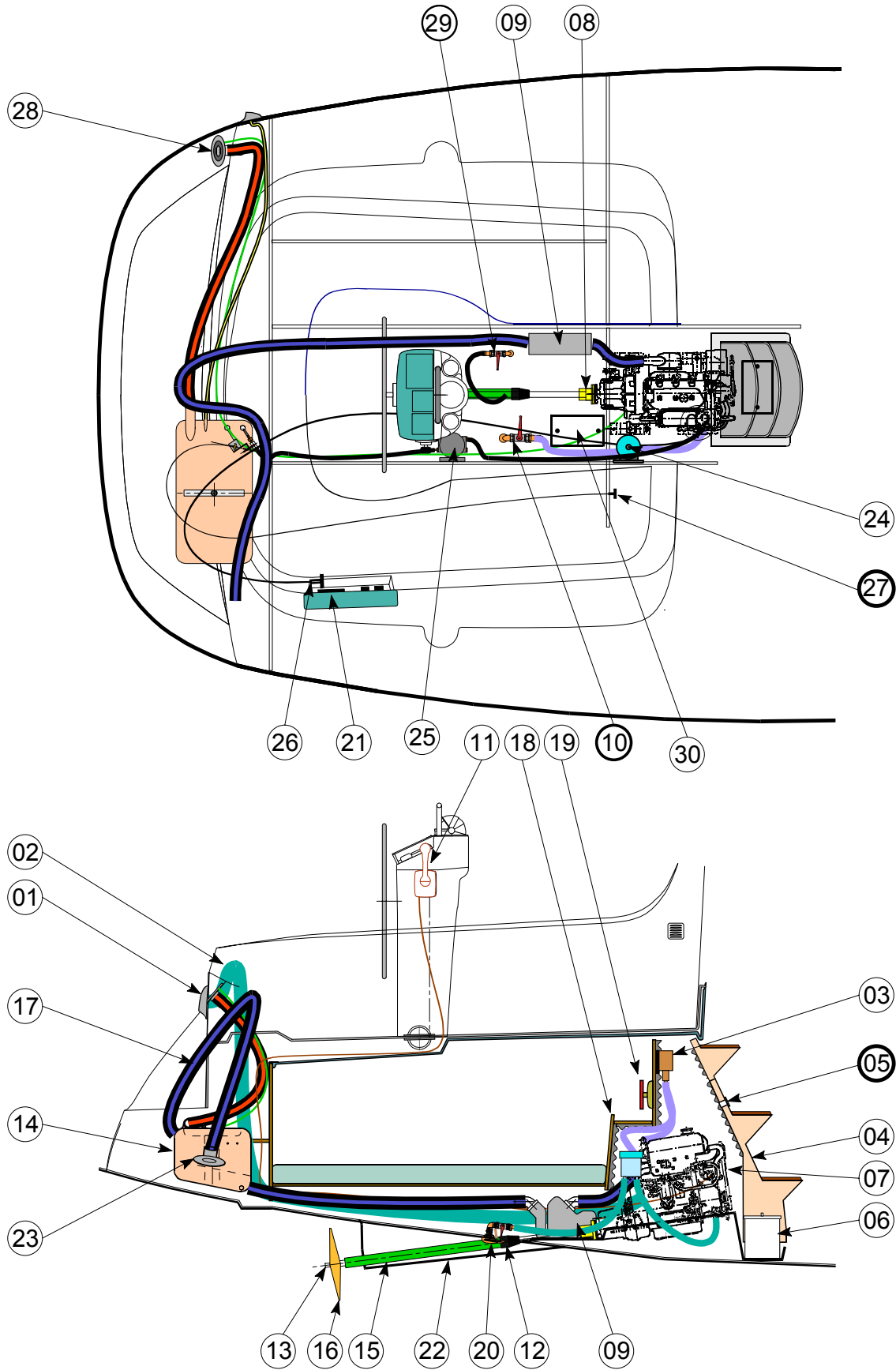

XXI) HANDLING

Contact your BENETEAU dealer for maintenance and repair of your boat. The dealer will advise properly, or will supply you with the spare parts you need or the materials that are suited to your boat.

Have your boat hauled & serviced once a year.

POSITION OF LIFTING STRAPS AND CRADLE POSITION.

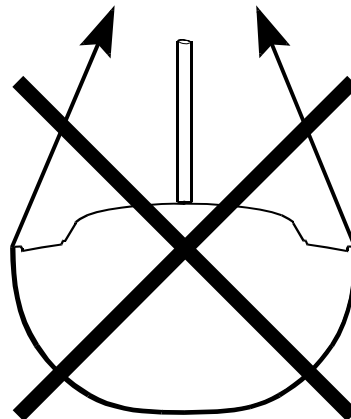
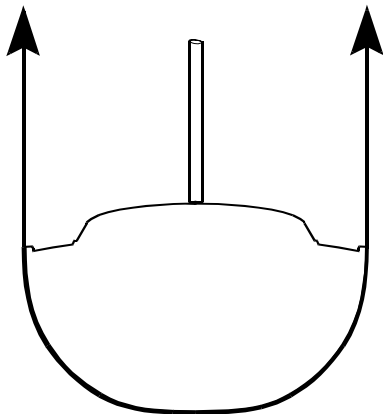
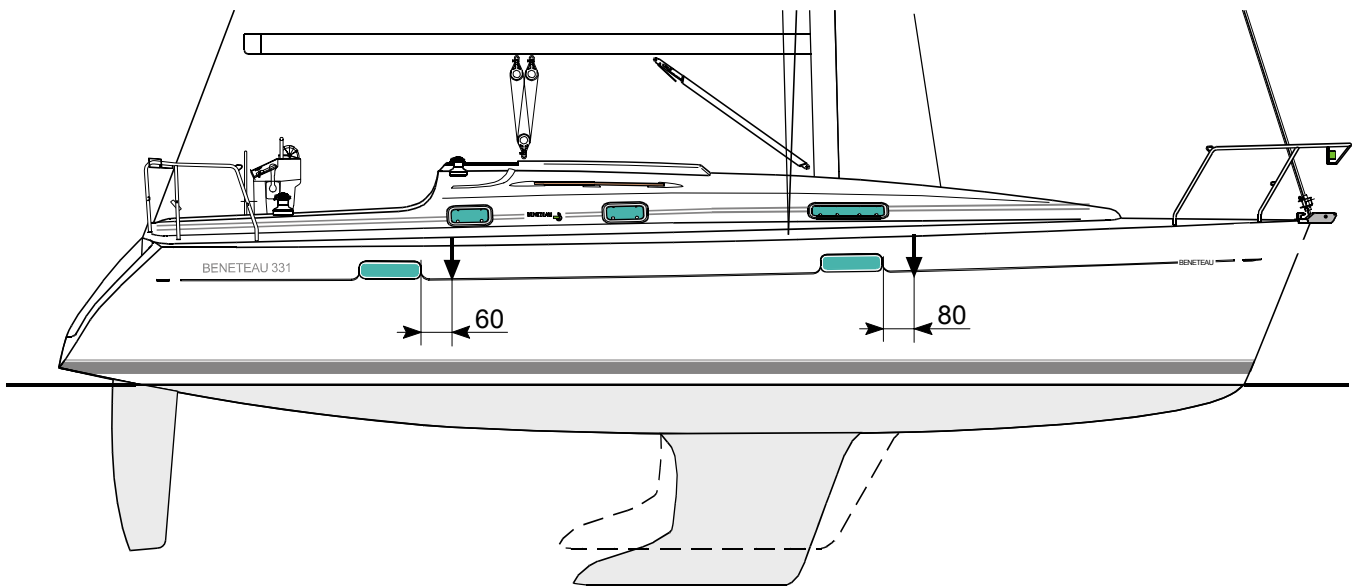

XXII) MAINTENANCE OF YOUR BOAT

Your boat represents a sizable capital investment that needs special and regular care. Safeguarding your investment and looking after your own safety should persuade you of the importance of careful and regular upkeep of your boat. The maintenance suggestions in the following sections will help you with the basics. Always refer to the original manufacturer's manual for specific guidelines on individual components.

NOTE: It is important to clean the bottom of your boat at least two or three times a year.

General Hull Maintenance

- **DO NOT SAND THE HULL WITH COARSE SANDPAPER.**
- **DO NOT USE SOLVENTS TO CLEAN HULL.**
- **DO NOT WASH WITH PRESSURE MACHINE USING WATER WARMER THAN 70 DEGREES F. (21 degrees C.).**
- **DO NOT USE PRESSURE EXCESS OF 2175 PSI (150 BAR.) WHEN USING A HIGH PRESSURE SPRAY WASH.**
- **DO NOT HOLD NOZZLE CLOSER THAN 4 INCHES (10 CM) TO SURFACE OF HULL.**
- **DO NOT MACHINE SAND.**

We believe the above points to be pertinent for all FRP boats.

GEL COAT

The gel-coat is vulnerable to any nicks and scratches it may get during maneuvering in harbor and on a mooring. The best way to avoid them is to undertake maneuvering calmly, after thinking out all the relevant factors (such as speed, current, wind, and the layout of the harbor). Always have one of the crew ready to put out a fender at the right place. When bringing in the anchor chain, back off or swing the boat round so as not to rub the chain against the hull. Hold the anchor well clear as you bring it aboard so that it does not scrape the stem: lay it on deck and lash it down at once, if only temporarily.

Never use dirty fenders.

Hose off the hull and deck as often as possible, with fresh water.

Before hosing down, remember to check that the hatch covers are closed; and it is wise not to take on diesel oil or fresh water supplies while you are hosing off the hull.

After a few years, the gel coat may be re-polished, either with a lambs wool buffer and polish, or by hand using a polish or similar product. Your yard will also be able to supply you with special cleaning products for getting rid of stubborn stains.

MINOR GEL COAT REPAIRS

To fill in a scratch or small nick, order a **Beneteau Gel coat Repair Kit** with instructions for use, from your dealer or obtain a small quantity of gel coat and catalyst.

Clean the affected area and rub it down with wet-and-dry sandpaper, then dry it off thoroughly (use a hair-dryer if necessary). Mix the components of the gel coat, and fill the scratch using a spatula avoiding any excess; cover with a sheet of cellophane. Once hardened remove cellophane and rub down with very fine wet/dry sandpaper (grade 600 or 800), and finish off by polishing the new surface.

THE DECK AND DECK FITTINGS

Using a gentle liquid detergent, scrub all nonskid areas to keep them free of dirt.

Light-alloy sections (tracks, etc.) can be cleaned in the same manner.

The tiny spots of oxidation pitting that may appear on stainless steel parts are nothing to worry about. Polishing will remove them.

From time to time, lubricate pulley blocks and sheaves, turnbuckles, tracks and travelers with light grease or a water-repellent lubricant such as WD-40 or Triflow.

After a certain time at sea, your winches will need cleaning inside. They must be cleaned out completely once a year. Follow the manufacturer's instructions carefully.

When dismantling deck fittings, have a bowl close at hand for putting the parts in, and circle the area with a rolled dishcloth, or the like, so that any screws or springs you drop do not roll overboard. Use the lubricant recommended by the manufacturer before reassembling.

Warning! Incorrect re-assembly can cause accidents. Note the order in which parts are dismantled, which will make it easier to put them together again later.

Acrylic plastic hatch covers and portholes should be rinsed off with fresh water and rubbed over with a soft cloth soaked in liquid paraffin.

THE RUDDER

Once a year, check steering gear. If necessary renew any parts (bushings, glands, etc.) that are worn. Lubricate the steering chain and cable and or gears.

Never lubricate Nylon, Ertalon or Teflon bushings, with either oil or grease, use only WD-40.

If you have wheel steering, maintenance should be in accordance with the manufacturer's recommendations.

Make regular checks on all the clamps, the condition of the quadrant, the cables or push rods, guide sheaves and the chain in the column to the wheel.

Make regular checks of the steering end stops to ensure they are adequately stopping the rotation of the rudder, this is important for direct drive push rod systems. Over rotation of the rudder could cause a steering lock up.

INTERIOR WOOD

The internal woodwork used in most of our boats is varnished. This should be regularly rinsed off with fresh water and a little liquid detergent, then polished with a chamois leather.

Should the woodwork become damaged, gently rub it down with very fine sandpaper and touch it with several coats of the varnish. Your dealer will be able to order Beneteau varnish. When this is dry, rub it down with a very fine wet-and-dry sandpaper (grade 800 or 1000) and finish off with polish (or a silicone spray) or wax.

ELECTRICAL SYSTEMS

It is essential for an electrical system to have a battery in sound condition to function properly. The following are some of the things to maintain a battery in the best condition.

- Keep the battery clean and the terminal posts well greased.
- Keep the battery electrolyte checked regularly
- Keep the battery fully charged.

If you have to leave your boat unused for more than a month it is best to leave your batteries with your yard so that they can be kept charged. Keep a suitable charger onboard so you can recharge your batteries at dockside without having to turn on the engine.

If you have an inboard engine, check the condition and tension of the alternator drive belt. From time to time, spray a little WD-40 or something similar on all the connections to the control panel, terminal boxes and lamp sockets. Make sure that cable grommets are watertight; smear them with Vaseline so that they do not dry out and deteriorate.

BATTERY MAINTENANCE

Make sure that the level of the electrolyte is always at least 1/2" above the top of the plates. This level can change suddenly, due to evaporation in an overheated bilge.

WARNING! THE ELECTROLYTE IN A BATTERY IS A SOLUTION OF SULFURIC ACID. IF ANY SHOULD ENTER THE EYES, RINSE IMMEDIATELY WITH LARGE AMOUNTS OF FRESH WATER, AND SEEK MEDICAL ATTENTION. ELECTROLYTE SPILLED ON SKIN SHOULD BE RINSED WELL WITH FRESH WATER. EVEN SMALL AMOUNTS OF ELECTROLYTE SPILLED ON CLOTHING WILL DESTROY THE CLOTHING.

If the level is low, fill the battery with distilled water and nothing else. The level of acidity (i.e. the relative density of the electrolyte) should also be checked from time to time.

CAUTION! USE ONLY PURE DISTILLED WATER TO REPLENISH ELECTROLYTE LEVELS. THE WATER FROM MANY CITY WATER SUPPLY SYSTEMS IS UNSATISFACTORY FOR BATTERY USE.

Keep battery connections clean and tight. A cup full of strong baking soda solution and a toothbrush will clean corrosion from the terminals and neutralize any spilled acid (do not allow any of the solution to enter the battery cells). A coating of petroleum jelly or silicone grease on the battery terminals will inhibit corrosion.

WATER SYSTEM

Check all joints regularly for leaks. Keep the tank(s) filled. If, however, you have to leave the boat unattended for several months, disconnect the water lines, purge them, and rinse them thoroughly with vinegar and water so that they do not form foul-smelling deposits.

Important: If the electric pump continues running when all the taps are closed, switch off the power supply at once and check the water system to find and overcome the leak that is causing this.

Check the thru-hulls, seacocks, connectors and hose clamps regularly. Make sure the seacocks turn freely.

MARINE HEAD

Maintenance consists of regularly pumping the system out with fresh water and leaving the holding tank empty whenever possible.

Check the thru-hulls, seacocks, connectors and hose clamps regularly. Make sure the seacocks turn freely.

ENGINE

Whether maintenance of the power system is to be performed by the owner or delegated to a mechanic, it is the owner who must first initiate any action that is to take place. He must either perform the maintenance or decide to call someone to do the job. A working knowledge of the power system is essential in the first case, and preventive maintenance desirable in the second. The engine manual is, of course, the prime source for engine information and should be consulted, preferably before the fact. The following paragraphs are included as a supplement to cover any required maintenance procedures that are not a part of the engine manual.

We have already stressed the points that are of importance for an engine to keep working properly. It might be added that the engine compartment should be kept scrupulously clean; check for any unusual oil or fuel leaks. Inspect all the electrical connections frequently.

Drain the bowl of the fuel/water separator at regular intervals to lessen the chance of water damage to your engine's fuel system. Keep fuel tanks filled.

Inspect the engine mounts and coupling for loose bolts regularly.

Check the oil and coolant levels everyday.

Check the alternator belt for the correct tension, keep a spare belt on hand.

Check all hoses and fuel lines for leaks regularly.

NOTE: Always have a spare set of sacrificial anodes on board, and regularly check those that are already fitted for deterioration; they should be replaced when their size has been reduced by half. The time this takes will vary with the waters in which the boat is used. Water temperature, salinity, the presence of neighboring boats, the nature of the bottom and the materials in the dock will all affect the life of your boat's anodes.

Order your spare anodes thru your dealer or from Beneteau Customer Service.

CALIFORNIA

Proposition 65 Warning

Diesel engine exhaust and some of its constituents are known to the State of California to cause cancer, birth defects, and other reproductive harm.

SAILS

Check the sails regularly, as the slightest wear in the stitching or at a reinforced part can very quickly have dramatic consequences. Keep a small sail repair kit on board and a book showing how to carry out minor work yourself until you can get the job done by a professional sail maker.

Keep a special eye on points where the sails can chafe on the rigging or fittings - turnbuckles, lifelines, shrouds, spreaders, etc.

Salt water and sunshine take their toll on sails. Whenever possible, rinse the sails in fresh water and leave them stretched out (preferably on a lawn) to dry. Never dry a sail by hoisting it and letting it flog in the wind; this will very quickly cause the sail to deteriorate. Never fold and store a damp sail.

XXIII) WINTERIZING PROCEDURES

The end of the season is a good time for a complete inspection of all of the boat's systems. It is easy to take shortcuts when decommissioning your boat but proper lay-up procedures will ensure trouble free recommissioning in the spring.

The following sections are oriented towards hauling your boat for winter storage in a cold climate, but they are also a good guideline as a lay-up procedure for your Beneteau in any climate.

An improperly winterized boat will lead to costly repairs and extensive delays, we recommend winterization by a competent yard or your Beneteau Dealer. The owner must ensure that the boat is correctly winterized.

HAULING

Your Beneteau should be hauled for inspection and maintenance at least once a year; the frequency of haul-outs may vary due to your local conditions and marine growth. A good boatyard is seasoned in hauling and maneuvering boats on land, you may verify this by checking to see that the weight of the hull is resting firmly on the bottom of the keel and that even contact exists along the bottom of keel. Jack stands, or cradle uprights, are meant to balance the boat and not to support its weight.

BOTTOM

Clean the yacht's bottom of any growth as soon as the boat is hauled. It is generally preferred to wait until spring to paint the bottom. Use the following guidelines when using a pressure washer:

MAXIMUM WATER TEMPERATURE TO BE 70° F. (21° C.)

MAXIMUM PRESSURE TO BE 2175 PSI (150 BARS) AT NO CLOSER THAN 4"

CUTLASS BEARING

The shaft strut contains a rubber type cutlass bearing. At haul out, be sure the bearing slots are clear and apply silicone lubricant or castor oil to the bearing to preserve its suppleness. Replace the cutlass bearing if excessive wear is evident. Be sure to realign the engine if the bearing is replaced. Bleed the prop shaft seal after re-launching

ZINC

Replace the sacrificial zinc before re-launching the boat.

FRESHWATER SYSTEM

This system is best winterized with one of the non-toxic antifreezes available for use in boat and recreational freshwater systems. It is an easy method, which replaces fresh water with a non-toxic antifreeze mixture.

Caution! Be sure to use non-toxic antifreeze in the fresh water system.

1. Allow the water in the water heater to cool, and open the pressure release valve on top. Disconnect the hot and cold water hoses and allow the tank to drain either in a bucket or into the bilge. Connect and clamp the hot and cold water hoses together using a short length of 1/2" pipe in order to bypass the heater.
2. Mix the appropriate amounts of antifreeze and water, as directed on the label, to deliver the degree of protection desired. Put 1-1/2 to 2 gallons of the solution into each water tank.
3. Open both tank selector valves on the manifold.
4. Turn on the pump and open all fixtures until antifreeze runs through. Be sure to open the hot water selector valve in order to supply antifreeze to the hot water hoses and through the bypass loop.
5. At this point, the freshwater system should be completely protected by antifreeze against freezing to a degree indicated by the strength of the solution placed into the supply tanks.
6. New boats delivered have their freshwater systems filled with antifreeze as described above, and are protected to -30 degrees F.

HEAD

Several days before completing haul-out procedures, fresh water should be allowed to stand in the head unit to dissolve any salt accumulation in the hoses and pump. Remove all water from the head. Special lubricants for the pump's internal mechanism are available. Check with your marine hardware dealer for a recommended brand. Never put oil, gas, kerosene, or alcohol in the head or they will ruin the internal valve.

Completely pump out all waste from the holding tank and pour in a cleansing, deodorizing solution. If possible, allow this to sit in the tank overnight, then completely pump out and drain the entire system. If antifreeze is used in the system, check in the manufacturer's literature for the recommended type.

ENGINE

Winterization by a marine mechanic is highly recommended to ensure that your engine is properly protected. Consult the Engine Owner's Manual for your specific engine's guidelines for winterizing. Follow the instructions carefully to ensure the engine is adequately protected. The general procedure is to replace raw seawater with an antifreeze solution mixed to protect the engine in your local area and to check the heat exchanger side to ensure that it contains an adequate antifreeze solution as well.

1. Prior to hauling the boat, run the engine to achieve normal operating temperatures in order to open the thermostat.
2. Close the raw water intake thru hull and remove the hose from the valve hose barb.
3. Insert the intake hose in a bucket of antifreeze solution and run the engine briefly until all raw water is flushed thru the exhaust system and only the antifreeze solution is expelled from the exhaust.
4. Be sure the thru hull valve is opened after the boat is hauled.

FUEL SYSTEM

Consult your engine manual to clean any engine mounted fuel filters.

Drain any water from the bottom of the fuel/water separator.

The fuel tank should be kept full for winter storage with about 5% expansion room left at the top. Empty fuel tanks encourage the formation of condensation.

BATTERIES

Clean battery terminals and cable ends thoroughly of any corrosion with a baking soda and water solution, and apply a light protective layer of petroleum jelly.

Batteries should be fully charged before storage, and the fluid level maintained. Store batteries in a warm, dry place. Do not store batteries directly on a stone or cement floor.

SEACOCKS

Open and drain all seacocks after boat is hauled. Open all seacocks for winter storage.

BILGE

Completely pump out bilge of any water and clean out any debris present. Bilge pumps should be pumped dry and hoses disconnected, to ensure that no water is left in the system.

ICEBOX

Remove any remaining food from the icebox and wash down thoroughly with warm water and detergent solution.

Odors can be removed with a baking soda and water solution, and an open box of baking soda left in the icebox will continue to remove odors throughout storage.

Completely pump out any water from the bottom of the icebox and make sure pump is completely dry of any water.

Leave icebox lid open during storage to allow ventilation.

STOVE

Depressurize the gas system and close all valves. Clean stove thoroughly. Remove fuel tanks and clean to remove any salt accumulation from their surface. Wipe down stove and tanks with a rag while applying a light layer of WD-40 or other lightweight, protective oil.

INTERIOR

Remove as much loose gear from the boat as possible and store in a clean dry place. If cushions are left on board be sure they are dry and propped on edge to encourage ventilation.

Rinse and dry all floorboards and store them on their edge to encourage ventilation. Leave all lockers clean and open for ventilation.

COVERING THE BOAT

Cover the boat adequately during storage to prevent excessive weathering.

BE SURE THE COVER DOES NOT CHAFE BOAT.

Ventilation between the winter cover and the boat is required to avoid build up of humidity.

CAUTION! DO NOT USE BLACK POLYETHYLENE AND DO NOT SHRINK-WRAP THE BOAT BY TAPING TO THE HULL. ALWAYS ASSURE GOOD VENTILATION.

SAILS

Remove the sails, clean following the sail makers recommendations and store in a clean dry space.

MAST

The aluminum mast requires a minimum of care and maintenance. At the end of each season it should be washed with a mild detergent and water solution, followed by a complete rinsing with fresh water. Tie off all halyards and lifts, and inspect the mast completely for scratches, cracks or stress marks. Apply paint or a clear lacquer to any scratches found to prevent corrosion. Consult your dealer or a marine rigger if any cracking or stressing of the aluminum tube is found.

Check all hardware on mast carefully for signs of corrosion, and check the tightness of the fastenings. Masthead sheaves should show no signs of wear and should move freely. Lubricate if necessary.

XXIV) SUPPLIER INFORMATION LIST

The following page lists our key suppliers in the United States. If you need information from a supplier not listed you may contact Beneteau's Customer Service Department in Marion, South Carolina at 1-843-423-4201.

Company Name	Contact Name	Product Type	Address	City	State	Postal Code	Phone Number	Fax Number	Web Site or E-Mail Address
Adler/Barbour		Refrigeration	PO Box 925	Clinton	CT	06413-	(860) 664-4906	(860) 664-4907	www.kenyonmarine.com
Aqua Signal		Lights	1680 E. Fabyan Parkway	Batavia	IL	60540-	(603) 232-6425	(603) 232-9481	
Atwood		Water Heaters	4750 Hiawatha Dr	Rockford	IL	61103-1298	(815) 877-5700	(815) 877-7469	
Doyle Sails	Andy Watts	Sails	Six Crossroads	St. Philips, Barbados	WI		(246) 423-4600	(246) 423-4499	doyle@caribnet.net
Exide Batteries	Detrich Epps	Exide/Fulman Batteries	201 Corporation Park Blvd	Columbia	SC	29233-	(803) 786-7050	(803) 735-3170	www.exideworld.com
Facnor SA	see JSI	Facnor Furling Units	Parc d Activites, B.P. 222	50550 SAINT-VAAST-LA-HOUGUE	FRANCE		011-33-2-33-88-50-22	011-33-2-33-88-50-22	
Force 10		Stoves	23080 Hamilton Road	Richmond,	VA		(800) 663-8515	(604) 522-9608	www.force10.com
Harken		Harken Blocks	1251 East Wisconsin Ave.	Pewaukee	WI	53072-	(414) 691-3320	(414) 691-3008	www.paw.com/sail/harken
Heart Interface		Heart Inverters	21440 68 th Ave. South	Kent	WA	98032	(253) 872-7225	(253) 872-3412	www.heartinterface.com
Isomat/Sparcraft	Jim Kulibert	Isomat Spars	1031 Amble Drive	Charlotte	NC	28206-	(704) 596-9449	(704) 597-7503	www.sparcraft.com
ITT Jabasco		Toilets, Pumps	1485 Dale Way	Costa Mesa	CA	92626-	(714) 545-8251	(714) 957-0609	www.jabasco.com
JSI		Cushions	3000 Gandy Blvd.	St. Petersburg	FL	33702-	(813) 577-3220	(813) 576-1306	www.jsisail.com
Lewmar - CA	Bob Davison	Lewmar Hardware	2439 West Coast Highway #201A	Newport Beach	CA	92663-	(714) 650-3366	(714) 650-7877	
Lewmar - FL		Lewmar Hardware	9203- 130 Ave North	Largo	FL	33773-	(813) 588-2580	(813) 581-6300	
Lewmar - FL		Frigoboat Refrigeration, Plastimo, Windlasses	6208-28th street East	Bradenton	FL	34203-4123	(800) 946-3521	(813) 746-7166	www.slusa.com
Marine Development		Battery Charger, Air Condition	P.O. Box 15299	Richmond	VA	23227-	(804) 746-1313	(804) 746-7248	
Morse Control		Shifter Cables	21 Clinton St.	Hudson	OH	44236-	(216) 653-7702	(216) 563-7799	
Neil Pryde Sails	Tim Yourieff	Sails	50 Broad Street	Milford	CT	06460-	(203) 874-6984	(203) 877-7014	www.paw.com/sail/neilpryde
Perko		Lights	P.O. Box 6400 D	Miami	FL	33164-	(305) 621-7525	(305) 620-9978	
Profurl	Mark Reuther	Profurl	401 N.E. 8th Street	Ft Lauderdale	FL	33304-	(800) 272-9511	(305) 763-8790	104200.666@compuserve.com
PYI		Whitlock Steering, Max Prop, PSS Shaft Seal	PO Box 536	Edmonds	WA	98020-	(206) 670-8915	(206) 670-8918	75032.1023@compuserve.com
Racor		Fuel Filter	P.O. Box 3208	Modesto	CA	95353-	(209) 521-7860	(209) 521-3278	
Raytheon Marine		Autohelm	46 River Road	Hudson	NH	03051-	(603) 881-5200	(603) 881-4756	www.raymarine.com
Scandvik		Sinks	980 36th Ct, SW	vero Beach	FL	32961-	(800) 535-6009	(407) 567-9113	
Seaward Products*		Hot Water Heaters	P.O. Box 566	La Puente	CA	91745-	(301) 699-7997		
Seco South	John Edwards	Running Rigging, Standing Rigging, Lifelines	2050 34th Way	Largo	FL	33771-	(813) 536-1924	(813) 539-6314	
Shurflow		Pumps	12650 Westminster Ave.	Santa Ana	CA	92706-2100	(800) 854-3218	(714) 554-4721	www.shurflow.com
Southcoast Marine		Stainless Steel Rails & Fitting	12550 47th Way North	Clearwater	FL	34622-	(813) 573-4821		
Spectrum Color		Custom Match Gel Coat	1410 37th Street N.W. Suite F	Auburn	WA	98001-	(206) 735-1830	(206) 735-3745	www.spectrumcolor.com
Todd Enterprises		Water and Fuel Tanks	530 Wellington Ave.	Cranston	RI	02910-	(401) 467-2750	(401) 467-2650	
Tops-N-Quality*		Stainless Steel Rails	P.O. Box 148	Marysville	MD	48040-	(313) 364-7150	(313) 364-7925	
Vetus	Leo VanHemert	Water Muffler, Anti-Siphon Valve	PO Box 8712	Baltimore	MD	21240-	(410) 712-0740	(410) 712-0985	www.vetus@aol.com
Welborn Marine	Max Hazelwood	Goiot Parts	1170 N.E. Cleveland Street	Clearwater	FL	34615-4836	(813) 445-9647	(813) 446-8800	www.maxone@aol.com
Westerbeke		Westerbeke Engines	Avon Industrial Park	Avon	MA	02322	(508) 588-7700	(508) 559-9323	www.westerbeke.com
Yanmar		Yanmar Engine	2365 Route 22	Union	NJ	07083-	(908) 964-0700	(908) 964-5032	engcity@eclipse.net

XXV) ENVIRONMENT

Do not pour oil overboard; use appropriate waste containers.

When you fill up the engine fuel tank, take all the precautions in order to avoid overflowing.

In the harbor, do not use the heads if they are not equipped with holding tanks.

The use of detergent contributes to the deterioration of the sea fauna and flora; choose entirely biodegradable products for your cleaning operations.

Do not throw plastic bags overboard.

You love the sea, just as we do; therefore, help us to protect it and do not pollute it.

XXVI) CENTERBOARD SYSTEM

To sail with the centerboard in the down position, lower the centerboard to the maximum then pull it up by one or two turns so the system will always be taut.

Be sure to lubricate the worm screw of the centerboard system at least twice a year (the boat will need to be hauled out in order to lubricate the worm screw).



To operate the centerboard insert a winch handle into the centerboard mechanism and turn counterclockwise to lower it and clockwise to raise it.



CENTERBOARD DOWN



CENTERBOARD UP



With the centerboard version it is possible for the boat to rest on the centerboard trunk and be balanced by the twin rudders when grounded during low tide (providing that it is sitting on a firm & stable bottom). Or when hauled out, the boat can be stored in this manner with a minimum of added support.