

RedCore™

Concept S-2

Indoor Infrared Stove Heater





CUSTOMER SUPPORT

***DO NOT RETURN THIS PRODUCT TO THE STORE
WHERE YOU BOUGHT IT***

FOR IMMEDIATE CUSTOMER SERVICE, PLEASE CALL:

**888-4BGT HEAT
(888-424-8432)**

**A CUSTOMER SERVICE REPRESENTATIVE WILL ASSIST YOU WITH ANY
QUESTIONS REGARDING YOUR CONCEPT S-2 STOVE HEATER**

Thanks for choosing the RedCore™ *Concept S-2* Infrared Stove Heater! We help our customers save money on energy bills while improving their comfort with state-of-the-art heating products. The RedCore™ *Concept S-2* Infrared Stove Heater is a durable room heater that produces soft infrared heating that will keep you comfortable and help you reduce energy bills.

Please refer to our website for further information on all RedCore™ products.

Best Green Technologies, LLC

E-Mail: sales@bestgreenllc.com

www.redcoreheaters.com

888-4BGT HEAT (888-424-8432)

PRECAUTION

WARNING 1: WHEN USING ELECTRICAL APPLIANCES, BASIC PRECAUTIONS SHOULD ALWAYS BE FOLLOWED TO REDUCE RISK OF FIRE, ELECTRIC SHOCK, AND INJURY TO PERSONS.

WARNING 2: RISK OF ELECTRIC SHOCK. NO USER-SERVICEABLE PARTS INSIDE.

WARNING 3: HEATER MAY BE HOT TO THE TOUCH WHEN IN USE. DO NOT TOUCH AREA NEAR HEATER ELEMENT WHEN HEATER IS OPERATING.

1. Read all instructions before using this appliance.
2. The heater is hot when in use. To avoid burns, do not place any objects such as furniture, papers, clothes, and curtains closer than 3 feet (0.9 m) to the front of the heater and keep them away from the sides and rear when the heater is plugged in.
3. Extreme caution should be taken when using any appliance around children, elderly, or disabled persons, or whenever the heater is operating unattended. Children under 14 years of age should not be allowed to operate this heater. This product is for adult use only and all children must be supervised when using this product.
4. Always unplug heater when not in use.
5. Do not operate heater with a damaged cord or plug, after the heater malfunctions, or if the heater has been dropped or damaged in any manner. Discard heater or return to an authorized service facility for examination and/or repair.
6. Do not use outdoors.
7. This heater is not intended for use in bathrooms, laundry areas, and similar indoor locations. Never locate appliance where it may fall into a bathtub or other water container.

8. Do not run cord under carpeting. Do not cover cord with throw rugs, runners, or similar coverings. Do not route cord under furniture or appliances. Arrange cord away from traffic areas and where it will not be tripped over.
9. To disconnect the appliance, turn Power Switch to off, wait for heater to cool down and shut off, and then remove plug from outlet.
10. Connect to properly polarized outlets only. This product requires a three prong outlet with ground.
11. Do not insert or allow foreign objects to enter into ventilation opening as this may cause an electric shock, fire or damage the appliance.
12. To prevent a possible fire, do not block air intakes or exhaust in any manner. Do not use on soft surfaces, like a bed, where openings may become blocked
14. Use this appliance only as described in this manual. Any use not recommended by the manufacturer may cause fire, electric shock, or injury to persons.
15. Always plug heaters directly into a wall outlet receptacle. Do not use an extension cord.
16. To prevent overload and blown fuses, be sure that no other appliance is plugged into the same outlet on the same circuit.
17. It is normal for the heater's plug and cord to feel warm to the touch. A plug or cord which becomes hot to the touch or becomes distorted in shape may be a result of a worn electrical outlet (receptacle). Worn outlets or receptacles should be replaced prior to further use of the heater. Plugging this heater into a worn outlet (receptacle) may result in overheating of the power cord or fire.
18. Be sure that the plug is fully inserted into an appropriate receptacle. Please remember that receptacles also deteriorate due to aging and continuous use: check outlet and cord

periodically for signs of overheating or deformations of the plug. If any overheating or deformation is present, immediately discontinue using the receptacle and contact a qualified electrician

19. CAUTION: To prevent electric shock, match wide blade of plug to wide slot of receptacle and insert completely.

20. Do not cover the appliance while it is functioning in order to avoid overheating and/or risk of fire.

21. Do not place the heater near a bed because objects such as pillows or blankets can fall off the bed and be ignited by the heater.

22. Check your heater cord and plug connections.

a) Faulty wall outlet connections or loose plugs can cause the outlet or plug to overheat. Be sure the plug fits tight in outlet.

b) Heaters draw more current than small appliances. Overheating of the outlet may occur even if it has not occurred with the use of other appliances.

c) During use, check frequently to determine if your plug outlet or faceplate is HOT!

d) If so, discontinue use of the heater and have a qualified electrician check and/or replace faulty outlet(s).

23. Do not locate against walls or behind drapes or furniture.

24. Be certain to clean the outer air filter in the rear of the heater periodically by vacuuming it and/or washing it to remove dust particles. Be certain to dry the filter completely prior to reinserting it into its position on the heater and prior to re-starting the heater

LEG ASSEMBLY

Before using your unit please install the legs as shown in diagram below.

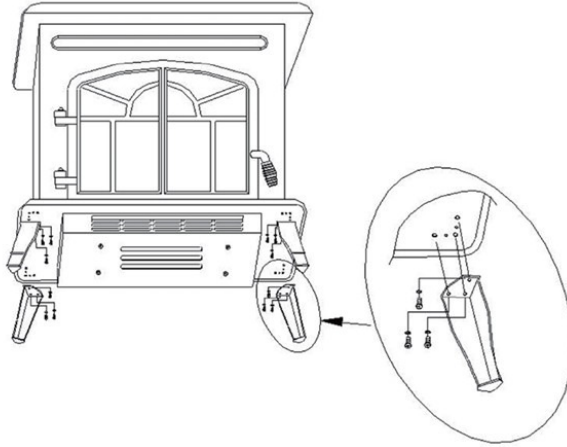

OPERATION

Controls and switches are located on front panel inside the glass door.

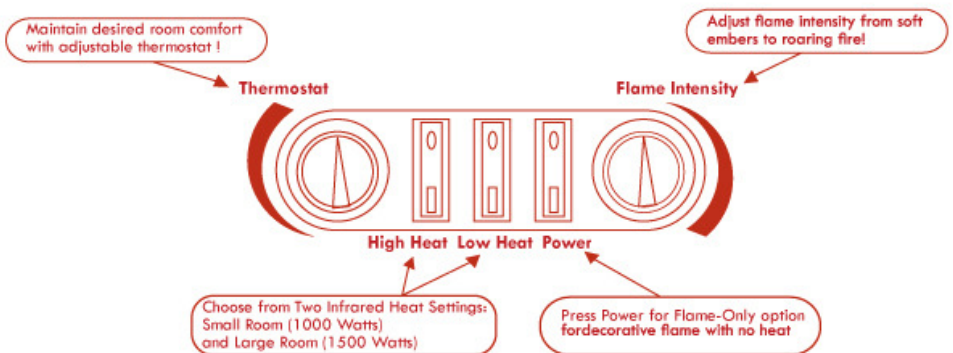

POWER: Press this button into the I position for main power and flame effect. The indicator light will turn on. See below for other control switches.

LOW HEAT: For low infrared heat function (1000 Watts), press this switch while the Power switch is in the I position for low heat. The indicator light will turn on.

HIGH HEAT: For high infrared heat function (1500 Watts), press this switch while the power and Low switches are in the I position for high heat. The indicator light will turn on.

THERMOSTAT: To adjust the temperature to your individual requirements, turn the thermostat dial to the right (clockwise) to increase the desired temperature and to the left for lower temperature. This thermostat control dial can only be used while the POWER switch and HEAT switches are in the I position. When the heater reaches the desired temperature, the heater and HEAT indicator light will turn OFF but the fan will continue to operate. Turning this knob (THERMOSTAT) to the right will increase desired temperature and restart the heater.

IMPORTANT: The heat output is controlled by the thermostat, according to the room temperature. Set the thermostat dial fully clockwise to the maximum position initially.

When the room is warm enough, reduce the setting by slowly turning the thermostat dial counter-clockwise until the heater “clicks.” This will then maintain the room temperature at the desired level.

FLAME INTENSITY: Turn the dimmer dial clockwise or counter clockwise to get the desired flame intensity. The dimmer switch can only be used when the POWER switch is in the I position.

NOTE: When the POWER switch is turned to the OFF position, all other heater

functions will stop even though the switches may be in the I position.

CAUTION:

If you use this heater in conjunction with a thermal control, a program controller, a timer or any other device that switches on the heater automatically, remember to observe all safety warnings at all times.

The stove heater has safety overheat protection. If the overheat protection trips, turn off the Power Switch and unplug the power cord from the receptacle. It will reset automatically after 5 minutes.

FLAME EFFECT

The flame effect is created with the use of a 40 watt B-10 candelabra light bulb with an E-12 (small) socket base. The light bulb will have to be replaced from time to time when it burns out.

During normal operation, the stove heater will always give you simulated flame function. If the intensity of flame suddenly increases, it means that the light bulb is going to burn out.

Replace the light bulb immediately, according to the instructions below. Do not operate the stove heater when the light bulb burns out or without the light bulb. Doing so will void the warranty.

CHANGING THE LIGHT BULB

1. Open the door of unit with the handle.
2. Loosen the 2 screws at the front of the log set inside the stove. Carefully lift the logset up far enough to access the light bulbs. You will find 1 X 40W Type B-10 candelabra light bulb with E-12 socket base at the bottom.
3. Replace burned out light bulb using new 40 watt Type B-10 candelabra light bulb.
4. Reinstall the logset.
5. Plug in the unit.

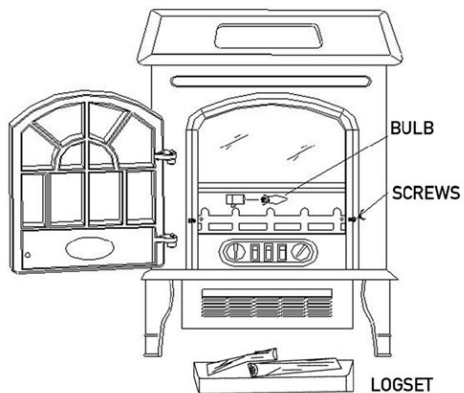

WARNING:

Disconnect power and unplug the power cord before attempting any maintenance or cleaning to reduce the risk of fire, electric shock or personal injury. The bulbs in your unit can become extremely hot. Allow at least ten (10) minutes between turning off the unit and removing the light bulbs to avoid the accidental burning of the skin.

CLEANING

To clean the stove heater first turn off Power and unplug the heater from its power source.

To clean the glass door, remove dust with a clean dry cloth or to remove finger prints and other marks clean glass with clean damp cloth. Do not use abrasive cleaners or spray liquids on glass door surface.

Metal and metal painted parts should be cleaned with damp cloth. Do not use abrasive cleaners or spray liquids on these surfaces.

BEST GREEN TECHNOLOGIES LLC

Limited Warranty & Limited Lifetime Warranty on PTC Heating Element Only

Best Green Technologies LLC (“BGT”) warrants this RedCore™ portable room heater to the original retail purchaser (“Purchaser”), for one year from the date of purchase, against defects in material and workmanship under normal use and service. BGT further warrants the following components:

- PTC ceramic heating element for lifetime of product.

Should your RedCore™ room heater prove defective within one year from the date of purchase, please follow our return procedure to return the defective unit. Within the first 30 days, BGT is responsible for the freight cost to and from our authorized service center for all units with a BGT authorized RMA. After 30 days and up to life of warranty, the customer is responsible for freight costs to and from our authorized service center.

Under no circumstances are products damaged in shipping covered under this warranty.

BGT’s sole obligation under this warranty is to replace, or at BGT’s discretion, to repair, free of charge, all defective parts according to the timeline described above. All replacement parts and units will be new, remanufactured, or refurbished. ANY IMPLIED WARRANTY OF MERCHANTABILITY IS SIMILARLY LIMITED TO ONE (1) YEAR FROM DATE OF ORIGINAL PURCHASE AND NO ACTION BASED UPON ANY IMPLIED WARRANTY OF MERCHANTABILITY OR OTHERWISE MAY BE COMMENCED AFTER EXPIRATION OF ONE (1) YEAR FROM DATE OF ORIGINAL RETAIL PURCHASE. Some states do not allow limitations on how long an implied warranty lasts, so the above limitation may not apply to you.

The provisions of this warranty shall not apply to any product which in BGT’s judgment has been (1) subject to misuse or neglect. (2) damaged in an accident or in shipping, (3) used for a purpose for which it was not designed, or (4) repaired or altered in any way that adversely affected its performance or reliability. Do not attempt to “open unit”, except for filter servicing and/or humidifier tank refilling. Opening unit will void manufacturer’s warranty.

THIS WARRANTY DOES NOT COVER:

- Damage, accidental or otherwise, to the unit while in the possession of the consumer not caused by a defect in material or workmanship.

- Damage caused by consumer misuse, tampering, or failure to follow the care and special handling provisions in the instructions.
- Damage to the finish of the case, or other appearance parts caused by the wear.
- Damage caused by repairs or alterations of the unit by anyone other than those authorized by Best Green Technologies.
- Subjective claims regarding decibel level of heater fan when product is operating at normal fan decibel levels.
- Freight and Insurance cost for the warranty service beyond 30 days from date of purchase up to life of warranty.

This warranty covers only new products purchased from our authorized dealers or retailers. It does not cover used, salvaged, or refurbished products.

To obtain warranty service, the defective product or part must be shipped or delivered to: Best Green Technologies, the Manufacturer. If warranty applies under BGT's approved terms, all shipping charges and insurance are covered by purchaser.

BEST GREEN TECHNOLOGIES LLC NEITHER ASSUMES NOR AUTHORIZES ANY PERSON TO ASSUME FOR IT ANY OTHER LIABILITY IN CONNECTION WITH ITS PRODUCTS. THERE ARE NO WARRANTIES WHICH EXTEND BEYOND THE DESCRIPTION ON THE FACE HEREOF. NO RESPONSIBILITY IS ASSUMED FOR INCIDENTAL OR CONSEQUENTIAL DAMAGES THAT MAY RESULT FROM THE USE OF A BGT PRODUCT, NOR FOR THE DAMAGES DUE TO ACCIDENT, ABUSE, LACK OF RESPONSIBLE CARE, THE AFFIXING OF ANY UNAUTHORIZED ATTACHMENT, LOSS OF PARTS, OR USE AT A VOLTAGE OTHER THAN SPECIFIED. Some states do not allow the exclusion of limitation of incidental or consequential damages, so these limitations may not apply to you. BGT disclaims all liabilities for defects or damages caused by use of replacement parts obtained from or by service at any service center other than Best Green Technologies.

This warranty gives you specific legal rights, and you may also have other rights which vary from state to state.

QUESTIONS? Call 1- 888- 424-8432 or visit www.redcoreheaters.com

Dear Customer: Please keep this warranty for your record. DO NOT return it.



CUSTOMER SUPPORT

***DO NOT RETURN THIS PRODUCT TO THE STORE
WHERE YOU BOUGHT IT***

FOR IMMEDIATE CUSTOMER SERVICE, PLEASE CALL:

**888-4BGT HEAT
(888-424-8432)**

**A CUSTOMER SERVICE REPRESENTATIVE WILL ASSIST YOU WITH ANY
QUESTIONS REGARDING YOUR CONCEPT S-2 STOVE HEATER**

www.redcoreheaters.com