



Soundfield

Classroom Voice Reinforcement

SYSTEM INSTALLATION GUIDE v3.0





i-ceilings Soundfield Systems provide a complete solution designed for use in teaching and training environments. They utilise the latest speaker and infrared technology to create sound reinforcement systems which combine the highest levels of performance and flexibility with the minimum of visual intrusion.

Please remember that Soundfield is a 'sound reinforcement' system, not a public address system; levels should therefore be set accordingly.



Typical Classroom Coverage:

Please note: These infrared Soundfield Systems are designed for use in a typical standard sized classroom (normally up to 60m²) and are not recommended for use in large room applications such as school halls, lecture theatres, sports halls, etc...

(For larger applications, we suggest using RF wireless microphone systems).

The IR wireless microphones use direct/reflected light emissions and, so, large non-reflective surfaces (light absorbent surfaces such as black/dark painted walls or large fabric coverage, etc...) in the classroom which may reduce coverage must always be considered in the system's performance.

Installation of 2 wall sensors in a classroom:

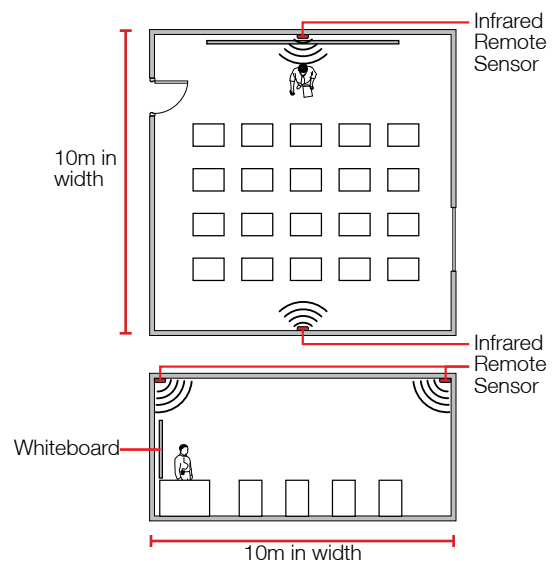

Please read this manual carefully before starting the installation and ensure you have all the equipment required.

This product should only be installed by a competent installer. The manufacturer accepts no responsibility for any resulting damage or consequential loss due to incorrect installation.

- It is essential that all equipment mounting trays and safety bonds (safety cable & security clips) are used and installed correctly.
- The amplifier will get warm during use, so please allow adequate ventilation around the unit.

Should you need to clarify any details with regards to the product or its installation, please contact our technical support team on 0115 977 0075; we are always happy to provide help and technical advice.

Soundfield Equipment Pack Lists



i-ceilings Soundfield Packs are supplied with the loudspeakers and infrared equipment in separate boxes.

Before going to site please check you have all the items required.

Detailed below are the contents lists for each of the various packs that are available...



• Soundfield Pack F

Pack A

1 x CS4000ME/AMP	Amplified Sound Panel Speaker
1 x APA/APL	CD/MP3/Laptop Wall Plate
1 x APA/TRAY	Equipment Support Tray
2 x 03284	Safety Cable
2 x 03518	Security Clip
1 x IWM-402	Pendant Transmitter/Microphone
1 x IWR-220	Infrared Receiver
2 x IS-20A	Infrared Sensor
2 x EXT CABLE 10	10 metre Extension Cord for IS-20A
1 x HC-40	Drop-in Charger for IWM-402
2 x AA	Batteries for IWM-402
1 x IC-1/IC-2	Connecting Cables
2 x Instructions	Installation and Operation Manuals

Pack F

4 x Speakers	Wallmount Loudspeakers
1 x IRX2	Soundfield Amplifier/IR Receiver
4 x 03284	Safety Cable
1 x IWM-402	Pendant Transmitter/Microphone
2 x IS-20A	Infrared Sensor
3 x EXT CABLE 10	10 metre Extension Cord for IS-20A
1 x HC-40	Charger for IWM-402
2 x AA	Batteries for IWM-402
1 x AV15276	Phono Coupler
2 x Instructions	Installation and Operation Manuals

Pack B

1 x CS4000ME/AMP	Amplified Panel Speaker
1 x CS4000ME	Sound Panel Speaker (slave)
1 x APA/APL	CD/MP3/Laptop Wall Plate
1 x APA/TRAY	Equipment Support Tray
2 x 03284	Safety Cable
2 x 03518	Security Clip
1 x IWM-402	Pendant Transmitter/Microphone
1 x IWR-220	Infrared Receiver
2 x IS-20A	Infrared Sensor
2 x EXT CABLE 10	10 metre Extension Cord for IS-20A
1 x HC-40	Drop-in Charger for IWM-402
2 x AA	Batteries for IWM-402
2 x Instructions	Installation and Operation Manuals

Pack G

1 x BP4500	Surface-mount i-ceilings Sound Panel
1 x IRX2	Wallmount Amplifier/IR Receiver
1 x 03284	Safety Cable
1 x IWM-402	Pendant Transmitter/Microphone
2 x IS-20A	Infrared Sensor
3 x EXT CABLE 10	10 metre Extension Cord for IS-20A
1 x HC-40	Charger for IWM-402
2 x AA	Batteries for IWM-402
1 x AV15276	Phono Coupler
2 x Instructions	Installation and Operation Manuals

Pack C

1 x PRO PANEL/AMP	Amplified Pro Sound Panel Speaker
1 x APA/APL	CD/MP3/Laptop Wall Plate
1 x APA/TRAY	Equipment Support Tray
2 x 03284	Safety Cable
2 x 03518	Security Clip
1 x IWM-402	Pendant Transmitter/Microphone
1 x IWR-220	Infrared Receiver
2 x IS-20A	Infrared Sensor
2 x EXT CABLE 10	10 metre Extension Cord for IS-20A
1 x HC-40	Charger for IWM-402
2 x AA	Batteries for IWM-402
1 x IC-1/IC-2	Connecting Cables
2 x Instructions	Installation and Operation Manuals

- IS-20A Standard Infrared Sensor
(For use with Soundfield Packs A, B, C, F & G)



- IS-30A Optional Ceiling Mounted IR Sensor
(For use with Soundfield Packs A, B, C, F & G)



- Ext. Cable 8 8 Metre IR Sensor Extension Lead
(For use with Soundfield Packs A, B, C, F & G)



- IWH-401 Handheld Transmitter/Microphone
(For use with Soundfield Packs A, B, C, F & G)



- 12W0031 Rechargeable Battery for IWM-402/IWM-401
(For use with Soundfield Packs A, B, C, F & G)



- 7W1B2V4 Rechargeable Battery for IWH-301A
(For use with Soundfield Packs A, B, C, F & G)



- APA/APL CD/MP3/Laptop Wall Plate
(For use with Soundfield Packs A, B, C)



- APA/LLO Radio Assisted Hearing Aid Output Plate
(For use with Soundfield Packs A, B, C)



- IRX/VC Volume Control Plate for IRX2
(For use with Soundfield Packs F & G)



Infrared Wireless Microphone Technology

This manual is intended for use by installation engineers. The separate user manual should be left with the user.

Infrared Wireless Microphone Technology:

As the Systems use wireless infrared to transmit the user's voice, some understanding of how this operates is useful...

Infrared is simply invisible light and acts in a very similar way to ordinary light, a useful feature in classroom applications. For example, infrared recognises walls as boundaries so multiple systems can be used without problems.

Whilst it is true that IR can be directional, all our emitters use high power LED arrays and detectors are wide angle. Infrared also readily reflects from walls, ceilings and windows so full coverage is easily achievable. Frequency allocation problems are eliminated and any transmitter can be used with any receiver; as a result these systems are both easy to commission and very flexible in use.



AC Power Requirements:

Pack A, B and C Systems:

A single 13 amp power point is all that is required as all ancillary Soundfield system items are powered directly from the panel amplifier. If two speakers are required, a further slave Sound Panel (set to 8 ohms) can be connected to the extension speaker terminals of the Panel Amp (see page 10 for connection details).

Pack F & G Surface-mount Systems:

A single 13 amp power point is all that is required as all ancillary items are powered from the IRX2 Wall Mounting Soundfield System.



Cable Requirements:

Mains & Audio:

All mains supply cables (terminated with 13 amp UK plugs) are included with kits, as are the interconnection cables between the infrared receiver and amplifier.



Infrared Receiver and External Detectors:

Two ready-terminated 8 metre coaxial extension cables are provided for the connection of the extension IS-20A infrared detectors. If required, these can be extended to 16 metres by means of a further extension cable and male-to-male coupler. For distances of over 20 metres please consult our technical support team.



For use with Pack A, B, C only:

A maximum of 5 Outreach Plates can be used with the i-ceilings amplified Sound Panel. The APA/APL (supplied with the packs) is intended to be used for the connection of a laptop, CD, MP3 player (or similar audio signal) and should be located in a convenient position near to the teaching position.

Outreach Plates are active with balanced outputs and, as such, can be daisy-chained together to provide multiple inputs as required, each with its own dedicated volume control. By this means it is possible to provide a flexible input structure to cater for almost any conceivable requirement.

Low Level Output Plates (APA/LLO):

These optional units are intended to facilitate the connection of individual hearing assistance systems to the Soundfield system. The plate is supplied with a 3.5mm 2pole jack socket with an output level of 775volts nominal, set by means of a user adjustable level control.

Cable requirements are as Outreach input plates, but a separate cable **must** be provided where this facility is installed.

All Outreach input and output plates require a single gang socket box with a minimum depth of 25mm.

(Only for use with Soundfield Pack A, B and C)



- APA/APL Outreach Plate for AV inputs



- APA/LLO Outreach Plate for assistive hearing systems

Outreach Plate connection cable specification:

The cable between the speaker panel, the first and any following Outreach Plates **must be to the following minimum specification:** 1 pair twisted and screened for audio, plus 1 additional pair for power. 'West Penn' 357 supplied by CIE-Group, or any good quality quad microphone cable should be suitable.

A wide range of Outreach Plates to suit various other interface requirements is available; please call CIE-Group for details.

Sound Panel Loudspeaker Installation

Sound Panel Loudspeaker positioning and installation (Packs A, C & G):

In systems using only one i-ceilings Sound Panel, the speaker unit should ideally be installed in the ceiling grid slightly to the rear of the classroom using the teaching position as a datum and as near as possible to the centre line of the other axis (see **Diagram 1**).

(Pack B):

When 2 panels are used, the exact positioning will be dictated by the shape of the classroom but the locations should be chosen to give the best possible coverage.

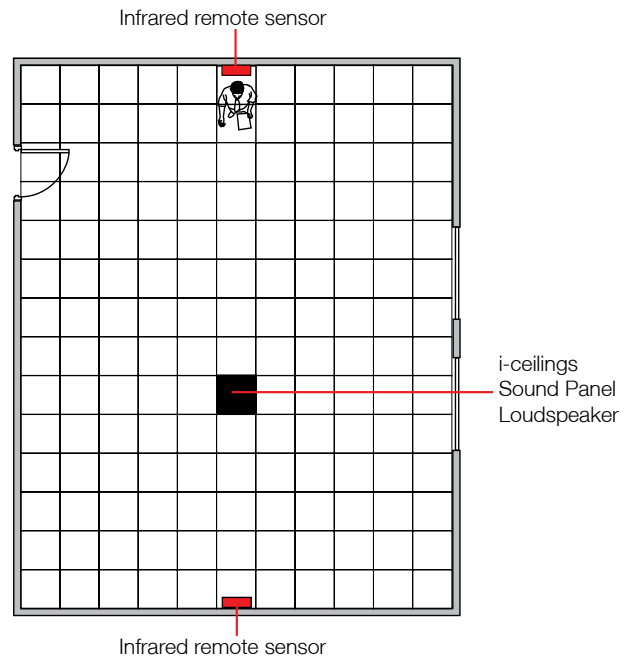

• Diagram 1

Sound Panel Cabling:

Take care to route all cables in such a way that they cannot rest on the rear of the Sound Panel.

When completing the installation be sure to fit the safety bonding wire to each speaker.

Finally check that no debris has been dropped on the panel. Remove everything; you would be amazed at the effect a 10mm cable off-cut can produce!

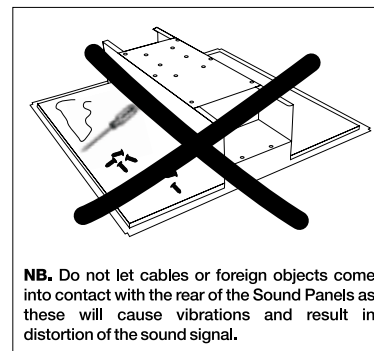

Remote Infrared Sensor (IS-20A) installation:

Two remote IR sensors are supplied with all kits. These should be installed at either end of the classroom just below ceiling level. Generally the centre of the wall behind the teaching position and the same position on the opposite wall will give the best coverage (see **Diagram 1 above**) (alternatively position on opposite sides of the room).

The IS-20A is a 170 degree wide angle detector and should be angled slightly downwards to give the best possible coverage.



Please ensure to make all connections before switching on power to the amplifier supply.

Care should be taken not to position the sensors in areas of high natural light as this will affect the performance of the IR Transmission. If unsure about coverage, please consult the CIE-Group Technical Support team on T. 0115 977 0075.



Safety Note

It is most important that the supplied safety cables and security clips are used and fitted correctly on each loudspeaker as part of the installation.

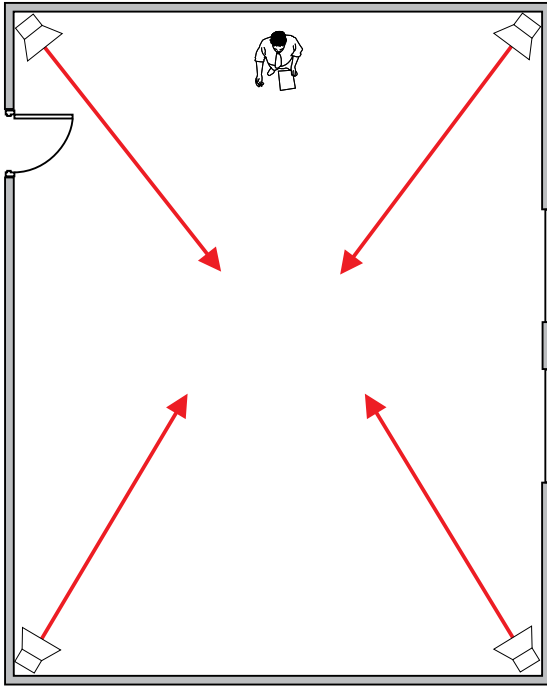

• Diagram 2.1 – wall speaker Position 1

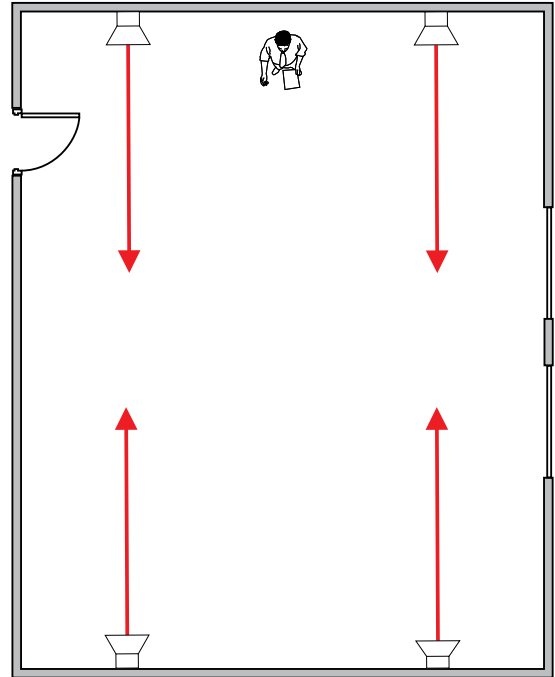

• Diagram 2.2 – wall speaker Position 2

Above are examples of typical loudspeaker locations for the classroom environment. Please see page 13 for loudspeaker wiring options.

Concealed Ceiling Soundfield System

When an Armstrong Sound Panel is used, the amplifier is an integral part. It supplies power to the IR receiver and any Outreach points as well as providing audio inputs and controls; please refer to 'AMP Sound Panels' section for details on connection and commissioning (Pack A, B, C).

IRX2 Wallmounting Soundfield System

However, where surface-mount speakers (Pack F & G) are used, the IRX2 Wallmount Soundfield System is provided as part of the kit. It should be installed adjacent to the whiteboard (or front of the classroom) at a height convenient to allow adjustment of the level controls.

Please refer to page 12 for details of IRX installation and commissioning.



'AMP' i-ceilings SoundPanels

Introduction:

'AMP' versions of i-ceilings Sound Panels feature a 20W power amplifier pre-installed on the Sound Panel. Sound Panels can be supplied with a wide range of ceiling finishes allowing the unit to be installed in any Armstrong suspended ceiling.

For advice on matching non-Armstrong suspended ceilings, please contact the CIE-Group sales team.



'AMP' Sound Panel Features:

The integrated amplifier has two inputs; one is at line level allowing the use of remote Outreach input plates such as the APA/APL, the other input is at a level suitable for connection to a Chiayo IWR220 (or similar infrared or RF wireless microphone receiver). An 18v DC supply is available from the amplifier to drive the Outreach plates and a 15v DC supply to power the IR receiver. Both inputs have their own level controls.

An additional line level output, 18v DC supply and external low impedance speaker output are also features of this unit.

The unit is fitted with 'High' and 'Low' tone controls to allow adjustment of the frequency response of the panel. The frequencies at which the controls operate have been chosen to allow speech clarity to be optimised to the acoustic environment.

All the connections to the unit are externally accessible and are of the removable screw terminal type, allowing for quick and easy connection.

Sound Panel AMP Specifications:

Rated Output:	20W RMS into 8 ohms
Frequency Response:	100Hz ~ 18kHz \pm 3dB
THD (At 1kHz):	Better than 0.1% at rated output
Tone Controls:	Low 1kHz \pm 12db High 10kHz \pm 12db
Line Input:	500mv, 600 Ohm balanced
Mic. Input:	200mv, 10k Ohm unbalanced
18v Output:	18v DC, fused at 100mA max.
15v Output:	15v DC, fused at 500mA max.
Line Output:	750mV, 600 Ohm Balanced
Power Consumption:	35W max.
Power Input:	230v AC 50Hz via IEC socket
Case:	White painted steel

Sound Panel 'AMP' Connection Details:
(refer to Diagram 3 on page 11)

- **Line In:**

Balanced line level input terminals for connection of up to five remote Outreach Input plates (APA/APL, etc).

- **Mic Rcvr In:**

Unbalanced microphone level input terminals for connection of a Chiayo IWR-220 infrared wireless microphone receiver. It is also possible to use this input to connect Chiayo RF radio microphone receivers. Contact CIE-Group Technical Support (0115 977 0075) for advice.

- **18v DC Out (Line Level / Line Sig Out):**

18v DC supply terminals providing power to the Outreach plates. These terminals will provide a combined maximum output current of 100mA.

- **15v DC Out: (Mic Rcvr)**

15v DC supply terminals providing power to the IWR-220 receiver only. These terminals will provide a combined maximum output current of 500mA.

- **Line Output:**

Balanced line level output terminals available on the IAPA for connection to the line level input of other equipment such as the APA/LLO Outreach plate or Induction Loop amplifiers. These can be used for connecting multiple i-ceilings panels in larger rooms where one speaker would not give sufficient sound coverage.

- **Ext Spkr:**

External 8 ohm speaker terminals for powering a single additional Armstrong CS1000 or Pro series panel. Note: damage to the amplifier will occur if speakers with a total impedance of less than 8 ohms are connected to these terminals.

- **Mains In:**

The mains input should be connected using an IEC type connector. The supply input should be 230V AC ($\pm 10\%$) 50Hz.



Warning

No connections should be made to the unit whilst the mains power is connected

Diagram 3 - Sound Panel 'AMP' Connection Details

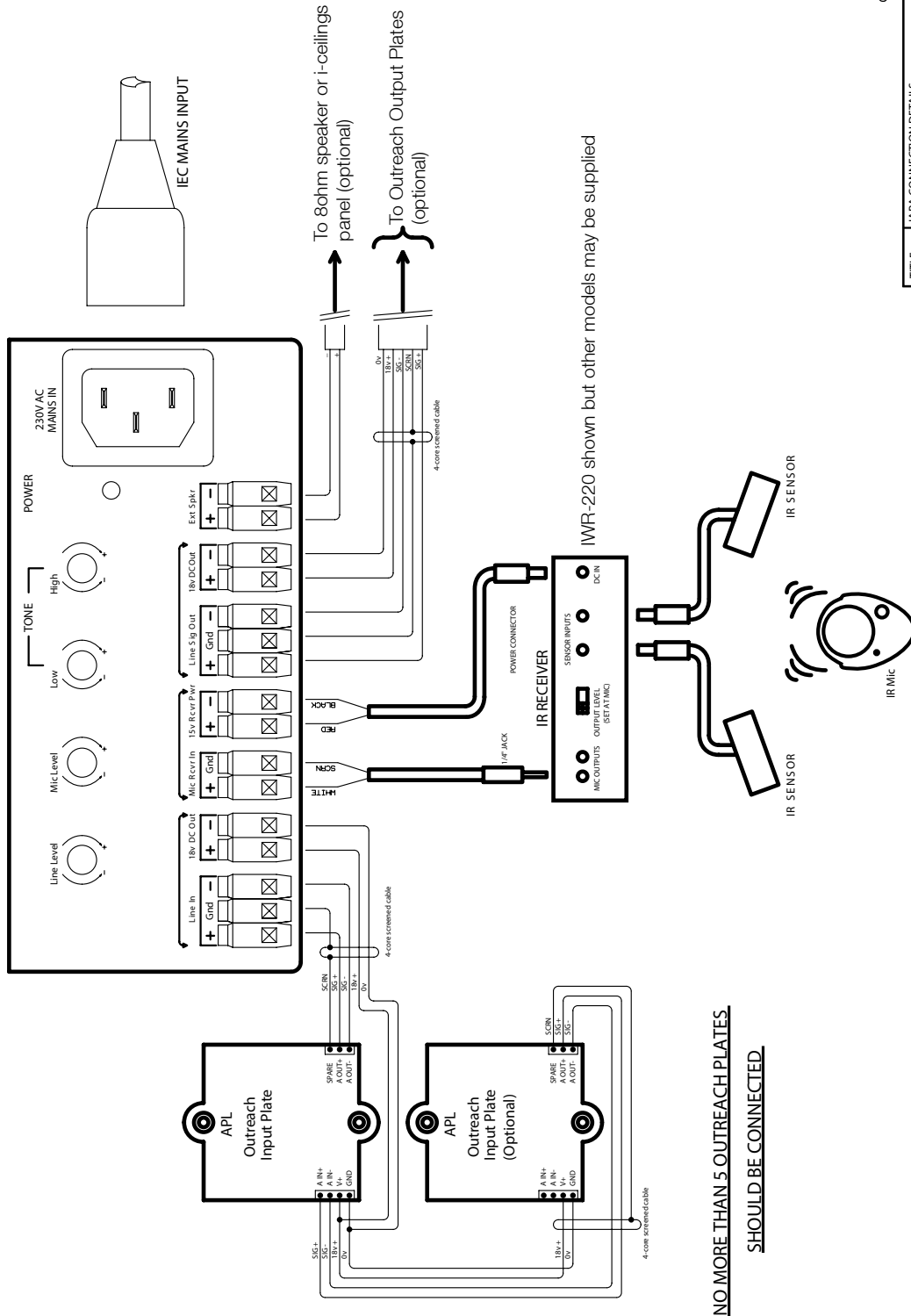

NO MORE THAN 5 OUTREACH PLATES SHOULD BE CONNECTED.

IWR-220 shown but other models may be supplied

cie-group

TITLE:	JAPA CONNECTION DETAILS	03/05/07
FILE:	JAPAInst.DSN	REV

IRX2 Wallmounting Soundfield System

The IRX2s unit is a wallmount system featuring 50 + 50W amplifier and in-built infrared receiver, developed specifically for Soundfield systems using conventional wallmount loudspeakers or the i-ceilings CS4500 surface-mount Sound Panel (Soundfield Packs F and G).

It has been designed to be both user-friendly in the classroom, whilst ensuring complete safety and security in such a welfare-critical environment.

The IRX2 features 4 inputs; one at Mic Level and three at line level. A designated 'ALD' (assisted listening device) output is provided to allow the interface of specialist hearing assistance equipment to the IRX2.

The IRX2 also includes low impedance loudspeaker output (minimum impedance 4 ohms) and a separate line level output and 12v DC supply for use with the charger base (HC-40) to recharge the IR microphone.

The IRX is fitted with 3 band tone controls to allow adjustment of the frequency response of the speakers. Frequencies at which the controls operate have been chosen to allow speech clarity to be optimised to the acoustic environment.

All signal connections to the unit are accessible only when the front cover is unlocked.



IRX2 Controls & Inputs/Outputs:

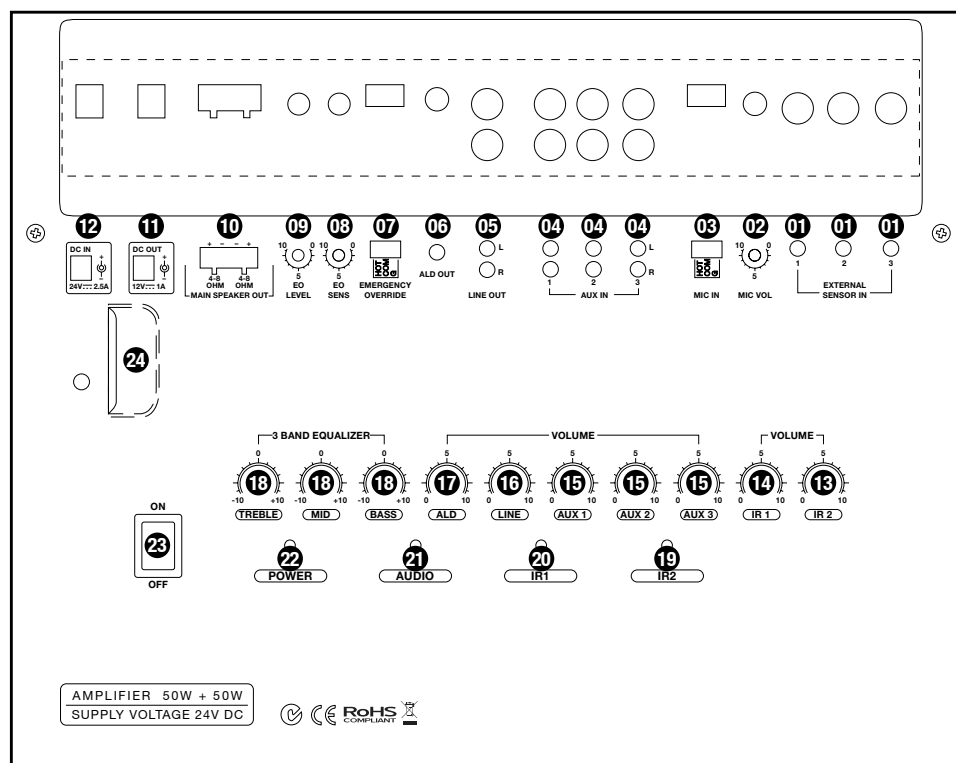

- 01) External sensor connectors: allows 3 external sensors to be used with this system
- 02) Mic In volume control
- 03) Mic In
- 04) Aux In: Allows 3 audio sources to apply to this system
- 05) Line Out
- 06) Audio output connector for assistive listening device: The volume level can be adjusted individually via the volume knob below
- 07) Emergency override (EO): When this function is activated, all operation of this unit will be stopped temporarily, emergency audio source will be amplified through this input. This function is specifically designed for emergency or public broadcast.
- 08) Sensitivity setting of emergency override (EQ): Clockwise to increase the sensitivity
- 09) Volume setting EO. Clockwise to increase the volume
- 10) Main Speaker out (R/L)
- 11) Power Output: Offers power for connected microphone charger (HC-40)
- 12) DC In
- 13) IR2 volume control
- 14) IR1 volume control
- 15) Aux In volume controls: individually for 3 audio inputs
- 16) Line Out volume control
- 17) Volume control of assistive listening device
- 18) 3-band tone controls. Individually for bass, middle and treble
- 19) IR2 reception indicator
- 20) IR1 reception indicator
- 21) Audio indicator
- 22) Power indicator
- 23) Power switch
- 24) Lock hole



Warning

No connections should be made to the unit whilst the mains power is connected

Diagram 4

The IRX Kit 2 (Pack F) is supplied with 4 x Loudspeakers

These can be installed in a number of ways depending on the size of environment and application required.

4 x Speakers:

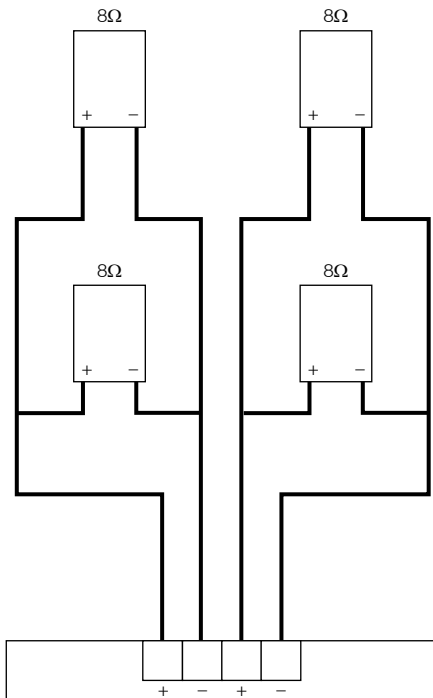

Produces A 4Ω Load per channel
Each channel wired in parallel

2 x Speakers:

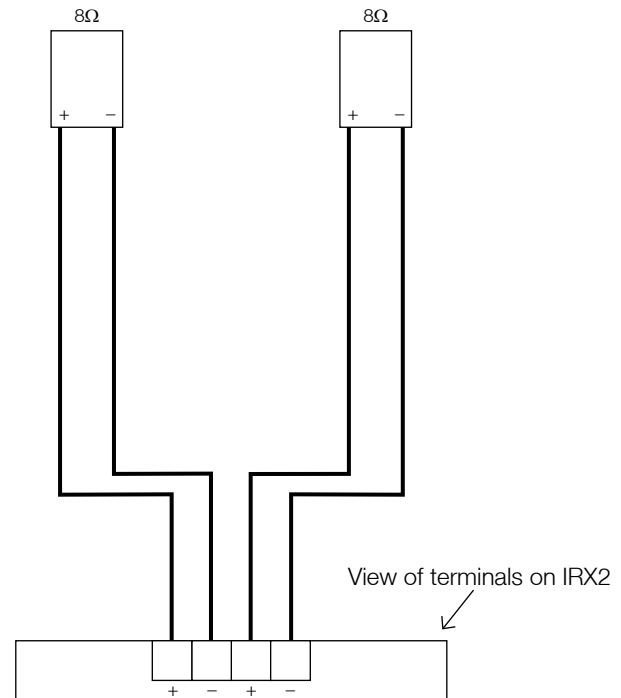

Produces A 8Ω Load per channel
Each channel wired in series

IRX Kit 2 Provides 2 x 50W @ 4Ω Load / 2 x 25W @ 8Ω Load

Important Note

Do not mix Loudspeaker Impedances between each amplifier channel as this can provide an unstable loading to the amplifier and possible amplifier failure.



- IRX2 Wallmount Amplifier/IR Receiver controls and connectors

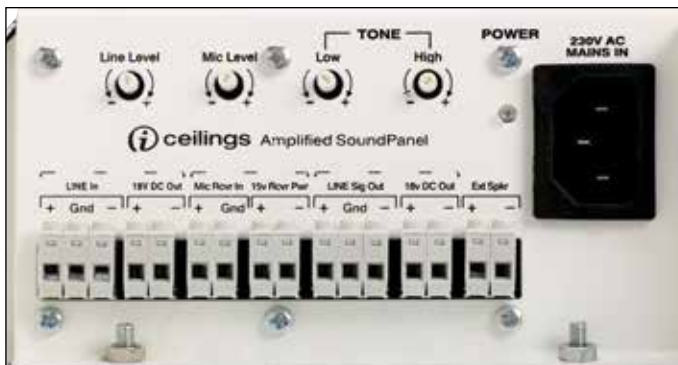

- i-ceilings Powered Sound Panel controls and connectors

Packs A, B, C, F & G:

Before testing the system, ensure that all the batteries required for the transmitters are fully charged.

After checking all the connections and wiring, set the line and Mic level controls to the half way point then connect the unit to the mains supply.

The Power LED on the amplifier (of either a Sound Panel Amplifier or the IRX2) will illuminate together with the green LEDs on any Outreach plates fitted. (If the green LEDs fail to illuminate, disconnect the supply and check the connections to the Outreach plates are correct.)

For Packs A, B and C **only**:

Set output level switch on the IWR-220 to MIC and switch the Receiver on; the red LED on the front panel should illuminate together with those fitted to the external IR sensors. The fixed equipment should now be operating.

Next test the APA/APL input plate(s) by feeding in a low level signal from a music source such as a CD, MP3 or laptop. Set the volume control on the plate to maximum then adjust the line input on the Sound Panel amplifier or IRX to produce a reasonable level over the room.

Remember a Soundfield System is not a PA system - the objective is to provide a comfortable listening level over the entire room. In an empty room the system needs to be set slightly louder than would normally be required. Do not try to adjust the tone controls at this point.

If more than one plate of the same type has been installed, all should be tested using the same method. If different type Outreach plates have been installed, each should be tested using a suitable input source.

Now set up and test the infrared microphone transmitters using the procedures on pages 15 and 16. If the system includes an IWH-301 hand Mic as well as a IWM-302 beltack, then set the hand Mic first.

Setting the Transmitter(s)



- IWM-402 Pendant IR Transmitter

IWM-402 Pendant Transmitter:

Remove the rear battery cover from the unit and insert a fully charged battery, ensuring the correct polarity, if you don't have any fully charged batteries to hand use Hi capacity AA cell for testing/set up purposes.

(IMPORTANT: see notes on page 16 regarding Chargers and Batteries)

Choose the required transmission channel A or B, the IR Receiver will operate on both, however if only one transmitter unit is to be used please set to channel A, and replace the rear cover.

Set the microphone volume level on the side of the transmitter to minimum and switch on the power, a green LED on the front of the transmitter will indicate power is present. The channel indicator LED on the Receiver should illuminate and should be the same as the pre set channel on the transmitter.

With the unit worn around the neck, gradually increase the volume level whilst speaking at a normal conversational level, the sound should be heard through the system speakers as the volume control is advanced. Ideally the level should be set at approx. 3/4 power before any feedback is possible, if feedback is encountered reduce the volume of the transmitter, or alternatively adjust the level of the amplifier unit installed to compensate.

The microphone may be muted at any time by pressing the mute button on the transmitter front, if muted this will illuminate red, and allows the internal microphone to be temporarily switched off when privacy or confidential conversations are required.

Check the IR Coverage (as per page 16)

IWH-401 Handheld Microphone:

Remove the battery cover by unscrewing the housing from the body of the microphone and insert a fully charged battery, ensuring the correct polarity, if you don't have any fully charged batteries to hand use Hi capacity AA cell for testing/set up purposes.

(IMPORTANT: See notes page 16 regarding Chargers and Batteries)

These are intended primarily as a "roaming" microphone for pupil interaction.

Other than an On/Off switch, the handheld microphone option has no other controls. Operation is indicated by a green LED which changes to red when the batteries are running low and require re-charging (see section on chargers and batteries below). You will find the microphone is very sensitive, talk in a normal voice holding the microphone at a distance of 6 to 8 inches (15 ~ 20cm) away from your mouth.

An optional lanyard/neck loop is also provided, which will allow the IWH-401 to be used hands free (just like the IWM-402 Pendant transmitter).



Checking the infrared coverage:

When the transmitters and detectors used on the installation have been set, check the infrared coverage in the teaching space or training room.

Whilst the infrared is, in theory, line of site it readily reflects off many surfaces (emitting power has also increased significantly in line with improvements in LED technology). Provided the two sensors are installed and angled correctly, and the transmitter batteries are charged completely, coverage of all areas likely to be used by the teacher should be readily achieved. If this is not the case the sensors should be checked.

Firstly ensure that the red LEDs are illuminated on both IS-20A sensors. Secondly test each individual sensor, preferably by substitution or, if a replacement is not available, by disconnecting each sensor in turn. The coverage with a single sensor should be distinctly poorer; if no change is observed suspect the sensors.

Please note complete coverage is unlikely to be achieved with only a single sensor.

Chargers and Batteries:

It is vitally important that the correct regime is adopted with regard to battery charging if the performance of the system is to be maintained. In normal use, fully charged batteries will power the transmitters for approximately 4 hours. Batteries will re-charge to 80% within 1 hour and fully within 5 hours using the supplied charger.

Microphone Type:	Charger Option:
IWM-402 Pendant Transmitter	HC-40 Drop-In Charger
IWH-401 Handheld Transmitter	HC-40 Drop-In Charger
IWH-302 Handheld Transmitter	HC-33 Drop-In Charger*

Important information

Your IWM-402 is supplied with a set of rechargeable batteries. However, if these should become lost or require replacement, it is critical that the following procedure is followed to allow your batteries to recharge correctly;

The IWM-402 has an inbuilt safety feature which will protect the Pendant and charger should someone insert standard AA batteries and attempt to recharge them.

When installing a new set of rechargeable batteries please trim off 15mm of the plastic cover/sleeving from the negative end of the battery, insert into the transmitter and place into the Drop In charger. If this procedure is not carried out then the charger will not recharge the installed batteries.

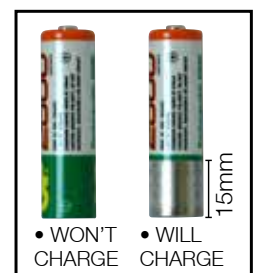

HC-40 Charging indicator LED

Solid Red	Charging
Solid Green	Fully Charged
Flashing Red	Poor battery condition/indication to replace or change the batteries

Note: Before charging either transmitter, please ensure that the batteries are installed the correct way around (pos-pos/neg-neg). Inserting the batteries the wrong way around will result in failure of/damage to the microphone transmitter. This is not covered under warranty.

Please demonstrate the equipment to the user and explain all the features and facilities. Make sure the user understands the charging and care of batteries. Finally leave the user manual with them, together with details of who to contact if service is required.



www.soundfield.uk.com

For further details on the i-ceilings Soundfield product range, its use and benefits in the classroom, please visit us online at: www.soundfield.uk.com

Product compliance:

These products comply with the following European directives:

- EMC directive 89/336/EC (plus amendments)
- Low voltage directive 72/23/EC (plus amendments)
- WEEE Directive 2002/95/EC
- RoHS Directive

Disposal:

When this product has reached the end of its useful life it must be disposed of in accordance with the European Parliament and Council Directive on Waste Electrical and Electronic Equipment (2002/96/EC) ('the WEEE Directive')

For disposal details, please go on-line to www.iceilings.uk.com/weee.htm



For further information on i-ceilings Soundfield Systems, please contact:

CIE-Group Ltd
 Widdowson Close,
 Blenheim Ind. Est.
 Bulwell, Nottingham,
 NG6 8WB, UK
 T. +44(0) 115 977 0075
 F. +44(0) 115 977 0081
 E. iceilings@cie-group.com
 W. www.cie-group.com

ceilings

‘SoundField’ or a ‘SoundField Voice Reinforcement System’ is essentially the integration of a ‘mini-PA system’ in the classroom.

Under quiet classroom conditions, most teachers have enough natural volume in their voice to communicate effectively with a standard sized class. However, a number of acoustic factors (lively/noisy classes, reverberant room conditions, ambient noise from equipment outside, hearing difficulties, etc...) can have a significant effect on clear, effective teacher/pupil communication.

The inclusion of a SoundField System in the classroom will raise the teacher’s voice above this ambient noise level, to give even voice coverage throughout the room and without the need to shout or raise one’s voice.



schools



colleges



universities



training centres

Approved Supplier:



An exclusive partnership between Armstrong World Industries and CIE-Group Ltd.

www.cie-group.com/soundfield

T: +44 (0)115 9770075 **F:** +44 (0)115 9770081 **E:** info@cie-group.com **W:** www.cie-group.com
 CIE-Group Widdowson Close Blenheim Industrial Estate Bulwell Nottingham NG6 8WB UK

This Brochure is
Fully Recyclable 