

# VIKING

# TECHNICAL Practice

TELECOM SOLUTIONS FOR THE 21ST CENTURY

**ES-3**  
**AES-2000/AES-2005**  
**Door Controller**

December 5, 2013

## Add Up to 32 Access Entry Points to Viking's AES-2000 or AES-2005 Accessible Entry System



Up to 32 additional points of entry can be added to Viking's model **AES-2000/AES-2005** Accessible Entry System. One **ES-3**, one Wiegand device and a door strike or magnetic lock of your choice is required for each additional entry point.

The **ES-3** is an entry system door controller designed to operate a door strike or magnetic lock upon receiving a valid card read from a Wiegand device. The Wiegand device used may be the **Viking** model **PRX-1** Proximity Card Reader and/or the **PRX-2** Proximity Card Reader with Keypad, **PRX-3** Medium Range Proximity Card Reader or **PRX-4** Wiegand Output Keypad or any other card reader, RF transmitter or digital keypad that outputs the 26 bit Wiegand format. Up to 525 valid

Wiegand codes can be programmed into the **AES-2000/AES-2005**, and up to 1024 access entry events are logged and stored in the **AES-2000/AES-2005**. Other programmable parameters, like relay activation and delay times, are also PC programmed via the **AES-2000/AES-2005**.

Only one pair of wires are needed to wire all 32 Entry System Door Controllers back to the **AES-2000/AES-2005**. This two wire CAN communication protocol allows the **ES-3** to be installed up to 1 mile away. A door sensor input monitors for a forced door or door ajar condition. A Request to Exit input operates the doors for people leaving the controlled area. Three separate relay outputs allow control of Door Strikes, Magnetic Locks, Gate Opener, Lights, Camera and or Alarm. Power to the **ES-3** can be daisy chained from unit to unit on a single pair of wires, or simply tap into the local door strike's power supply.

## Features

- Up to 525 tenants
- Up to 32 entry points are possible
- Logs up to 1024 entry events
- Compatible with Viking models **PRX-1**, **PRX-2**, **PRX-3**, and **PRX-4** and certain legacy 125KHz HID® proximity card readers\*
- Two wire CAN communication protocol can be daisy-chained together
- Use supplied power adapter or share with door strike's 12-24 Volt AC or DC power source
- Inputs may be either normally open (NO) or normally closed (NC) contacts
- Relay outputs provide either normally open (NO) or normally closed (NC) contacts

\* HID and the HID logo are registered trademarks of HID Global Corporation, an ASSA ABLOY company. All other trademarks are the property of their respective owners.

Phone... 715.386.8861  
[www.vikingelectronics.com](http://www.vikingelectronics.com)

## Applications

- High rise apartment buildings
- Condos
- Senior citizen buildings
- Assisted care centers
- Retirement homes
- Gated communities

## Specifications

**Power:** Any 12-24 Volt AC or DC source @ 300mA, 12V DC adapter included (Designed to share power with the local door strike's power supply)

**Dimensions:** 133mm x 89mm x 44mm (5.25" x 3.5" x 1.75")

**Shipping Weight:** 1.3 kg (3 lbs)

**Environmental:** 0° C to 32° C (32° F to 90° F) with 5% to 95% non-condensing humidity

**Relay Contact Ratings:** 3A @ 30V DC/250V AC maximum

**Connections:** 18 screw terminals

**Maximum CAN Length:** 0.8 Km (2600 ft) - 24 AWG twisted pair, 1.6 Km, (5300 ft) - using 2 pairs of 24 AWG twisted pair

**Maximum Wiegand Run (24 AWG):** **PRX-1:** 122m (400 ft), **PRX-2:** 53m (175 ft), **PRX-3** (using 3 pairs for power): 91m (300 ft), **PRX-4:** 244m (800 ft)

# Warranty

## IF YOU HAVE A PROBLEM WITH A VIKING PRODUCT, PLEASE CONTACT: VIKING TECHNICAL SUPPORT AT (715) 386-8666

Our Technical Support Department is available for assistance Monday 8am - 4pm and Tuesday - Friday 8am - 5pm central time. So that we can give you better service, before you call please:

1. Know the model number, the serial number and what software version you have (see serial label).
2. Have your Technical Practice in front of you.
3. It is best if you are on site.

### RETURNING PRODUCT FOR REPAIR

The following procedure is for equipment that needs repair:

1. Customer must contact Viking's Technical Support Department at 715-386-8666 to obtain a Return Authorization (RA) number. The customer MUST have a complete description of the problem, with all pertinent information regarding the defect, such as options set, conditions, symptoms, methods to duplicate problem, frequency of failure, etc.
2. Packing: Return equipment in original box or in proper packing so that damage will not occur while in transit. Static sensitive equipment such as a circuit board should be in an anti-static bag, sandwiched between foam and individually boxed. All equipment should be wrapped to avoid packing material lodging in or sticking to the equipment. Include ALL parts of the equipment. C.O.D. or freight collect shipments cannot be accepted. Ship cartons prepaid to: **Viking Electronics, 1531 Industrial Street, Hudson, WI 54016**
3. Return shipping address: Be sure to include your return shipping address inside the box. We cannot ship to a PO Box.
4. RA number on carton: In large printing, write the R.A. number on the outside of each carton being returned.

### RETURNING PRODUCT FOR EXCHANGE

The following procedure is for equipment that has failed out-of-box (within 10 days of purchase):

1. Customer must contact Viking's Technical Support at 715-386-8666 to determine possible causes for the problem. The customer MUST be able to step through recommended tests for diagnosis.
2. If the Technical Support Product Specialist determines that the equipment is defective based on the customer's input and troubleshooting, a Return Authorization (R.A.) number will be issued. This number is valid for fourteen (14) calendar days from the date of issue.
3. After obtaining the R.A. number, return the approved equipment to your distributor, referencing the R.A. number. Your distributor will then replace the product over the counter at no charge. The distributor will then return the product to Viking using the same R.A. number.
4. **The distributor will NOT exchange this product without first obtaining the R.A. number from you. If you haven't followed the steps listed in 1, 2 and 3, be aware that you will have to pay a restocking charge.**

### LIMITED WARRANTY

Viking warrants its products to be free from defects in the workmanship or materials, under normal use and service, for a period of one year from the date of purchase from any authorized Viking distributor or 18 months from the date manufactured, whichever ever is greater. If at any time during the warranty period, the product is deemed defective or malfunctions, return the product to Viking Electronics, Inc., 1531 Industrial Street, Hudson, WI., 54016. Customer must contact Viking's Technical Support Department at 715-386-8666 to obtain a Return Authorization (R.A.) number.

This warranty does not cover any damage to the product due to lightning, over voltage, under voltage, accident, misuse, abuse, negligence or any damage caused by use of the product by the purchaser or others.

**NO OTHER WARRANTIES.** VIKING MAKES NO WARRANTIES RELATING TO ITS PRODUCTS OTHER THAN AS DESCRIBED ABOVE AND DISCLAIMS ANY EXPRESS OR IMPLIED WARRANTIES OR MERCHANTABILITY OR FITNESS FOR ANY PARTICULAR PURPOSE.

**EXCLUSION OF CONSEQUENTIAL DAMAGES.** VIKING SHALL NOT, UNDER ANY CIRCUMSTANCES, BE LIABLE TO PURCHASER, OR ANY OTHER PARTY, FOR CONSEQUENTIAL, INCIDENTAL, SPECIAL OR EXEMPLARY DAMAGES ARISING OUT OF OR RELATED TO THE SALE OR USE OF THE PRODUCT SOLD HEREUNDER.

**EXCLUSIVE REMEDY AND LIMITATION OF LIABILITY.** WHETHER IN AN ACTION BASED ON CONTRACT, TORT (INCLUDING NEGLIGENCE OR STRICT LIABILITY) OR ANY OTHER LEGAL THEORY, ANY LIABILITY OF VIKING SHALL BE LIMITED TO REPAIR OR REPLACEMENT OF THE PRODUCT, OR AT VIKING'S OPTION, REFUND OF THE PURCHASE PRICE AS THE EXCLUSIVE REMEDY AND ANY LIABILITY OF VIKING SHALL BE SO LIMITED.

IT IS EXPRESSLY UNDERSTOOD AND AGREED THAT EACH AND EVERY PROVISION OF THIS AGREEMENT WHICH PROVIDES FOR DISCLAIMER OF WARRANTIES, EXCLUSION OF CONSEQUENTIAL DAMAGES, AND EXCLUSIVE REMEDY AND LIMITATION OF LIABILITY, ARE SEVERABLE FROM ANY OTHER PROVISION AND EACH PROVISION IS A SEPARABLE AND INDEPENDENT ELEMENT OF RISK ALLOCATION AND IS INTENDED TO BE ENFORCED AS SUCH.

# Definitions

**26 bit Wiegand Format:** The industry standard data output protocol of access control card readers.

**CAN Communications:** A highly reliable two wire communication protocol originally developed for the automotive industry.

**Door is Ajar Condition:** The door sensor input shows that the door remained open longer than a programmed amount of time.

**Entry Point:** A door or gate allowing access into a secure or controlled area.

**Facility Code:** A 3-digit number that each proximity card contains in order to provide greater security. Usually the cards used at a given building all have the same facility code. By programming cards with different facility codes, these cards can have access to certain doors. Using this feature, the entry system can be set up for "zones".

**Forced Door Condition:** The door sensor input shows that the door has opened, without the **ES-3** allowing for access.

**Proximity Card:** A credit size card that identifies itself when within close proximity of a reader. Card "swiping" is not necessary. The card contains a 3 digit Facility Code, a 5 digit Internal Card number and a 5 digit External Printed number, that may or may not match the Internal number.

**Proximity Card Reader:** A device used to read the data from a Proximity Card when it's within a few inches of the reader.

# Installation

## A. Basic Wiring

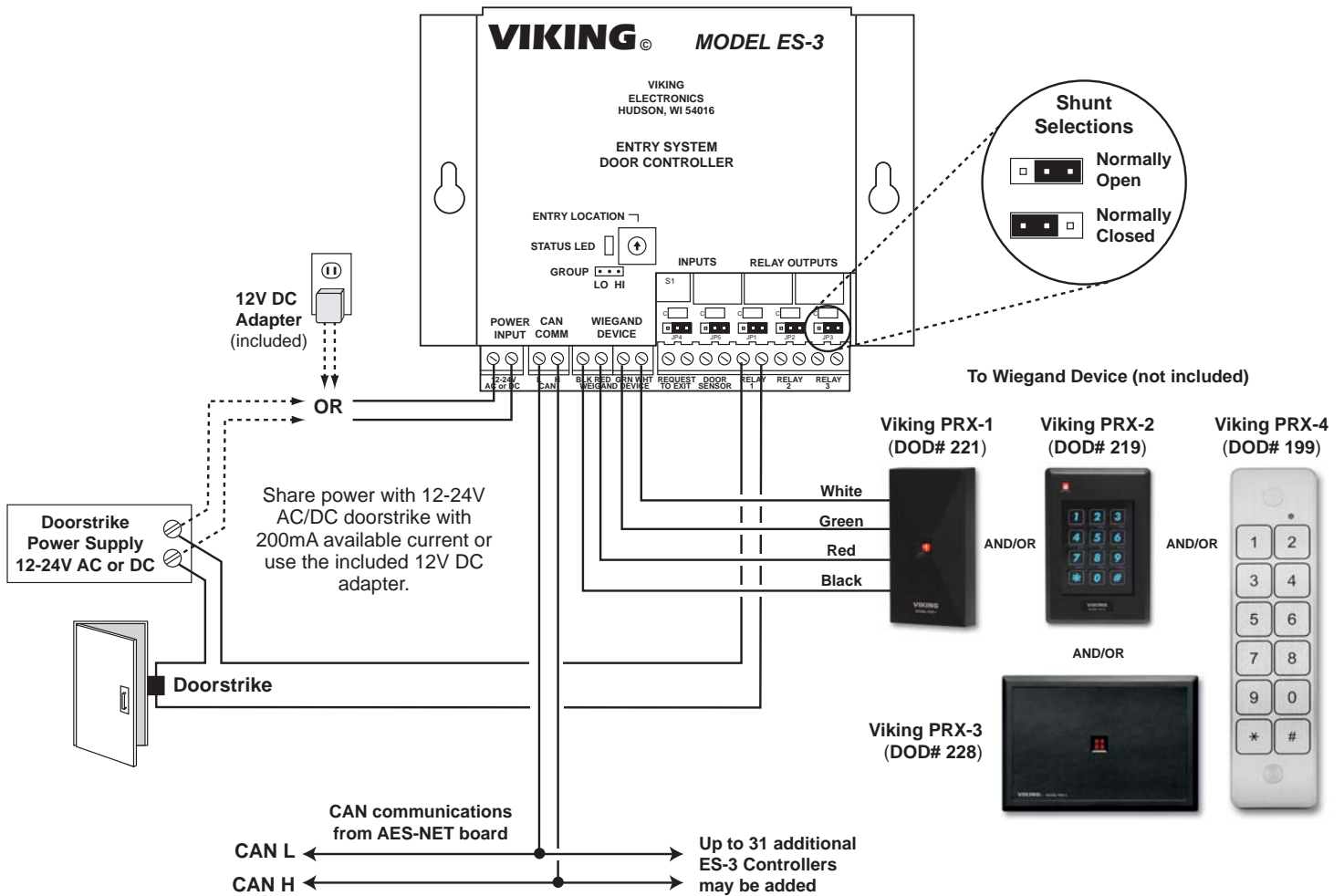

A basic door access controlled entry point is wired as shown above. The **ES-3** is designated to share power with the attached door strike or magnetic lock. Voltage needs to be between 12-24 Volts with an additional 300 mA of current available or use the included 12V DC adapter.

Relays can be set as either Normally Open (NO), or Normally Closed (NC) using the shunt located directly behind the relay screw terminals.

The Wiegand device (typically a proximity card reader) is fully supported (power and data) from the **ES-3** and can be installed up to 500 feet away using 24 gauge wire.

The **ES-3** communicates with the **AES-2000/AES-2005** through the built-in **AES-NET** network interface via a two wire CAN Communication Bus. CAN bus distances of up to 1/2 a mile (over 2600 feet) are achieved using common 24 gauge CAT-2 through CAT-5 wire, and 1 mile (5280 feet) is possible by doubling up on the 24 gauge twisted pair (or running at least 21 gauge). In addition, up to 32 **ES-3** entry system door controllers may share the same CAN communication pair.

## B. Advanced Wiring

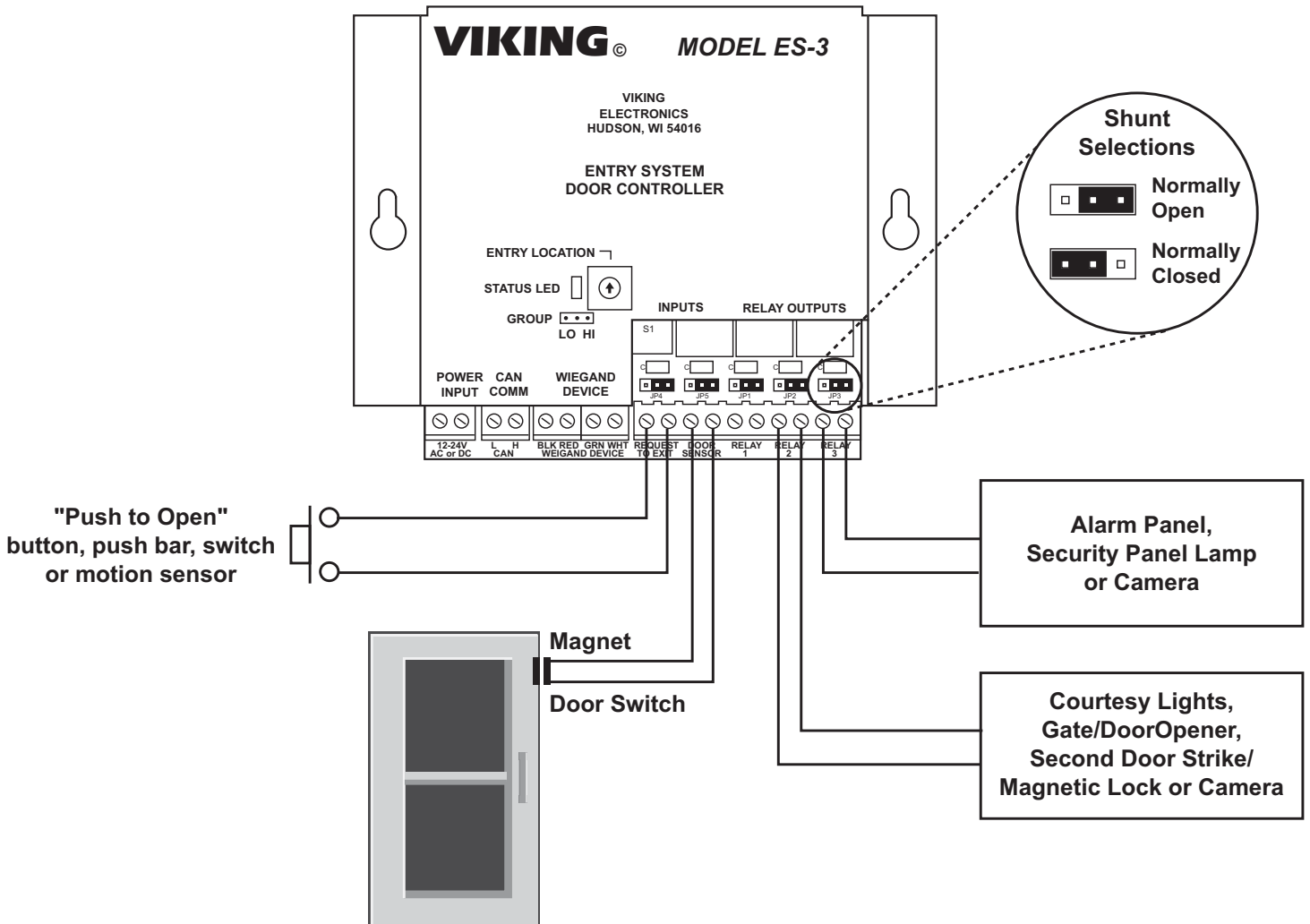

The **ES-3** can be wired with either a normally open or a normally closed Door Sensor switch by setting the shunt located directly behind the Door Sensor screw terminals to either Normally Open (NO), or Normally Closed (NC).

The **ES-3** can be wired with either a normally open or a normally closed Request to Exit device switch by setting the shunt located directly behind the Request to Exit screw terminals to either Normally Open (NO), or Normally Closed (NC).

Relay 2 can provide either a Normally Open (NO), or Normally Closed (NC) contacts to control (switch on) a courtesy light, a gate/door opener, a second door strike/magnetic lock, or start a camera. Use the shunt located directly behind the relay screw terminals to set the normal state.

Relay 3 can provide either a Normally Open (NO), or Normally Closed (NC) contacts to trigger an alarm, activate a security panel lamp, or start a camera. Use the shunt located directly behind the relay screw terminals to set the normal state.

# Programming

## A. Assignment

Each **ES-3** (up to 32 total) must be assigned with its own unique entry point location identifier. With the shunt set to Low Group, 16 different rotary switch positions are available. After these 16 have been used, set the remaining units to the High Group for 16 more settings using the same rotary switch.

**IMPORTANT: Do NOT set group shunts and rotary switches until the entire system is wired and powered up.**

If an **ES-3** is installed with a duplicate entry point location identifier, the Status LED will flash. Simply move the shunt/rotary switch to a new position. The Status LED will momentarily go off, then come on steady to show it has its own unique entry point location identifier.

## B. ES-3

Each **ES-3** and all valid card numbers must be programmed in the system for proper operation. This programming is done through the telephone line interface of the **AES-2000/AES-2005** using the **PB-100** with special software. This allows either remote programming from a distant location, or local programming using the Viking **DLE-300** line simulator. The **PB-100** is connected to a serial port of a P.C. and Windows based software is used to enter relay activation times and alarm conditions for each **ES-3** and the valid card numbers in the **AES-2000/AES-2005** data base.

Access the Remote Programmer software as described in the **AES-2000/AES-2005** Technical Practice. Proceed through the "Building Selection", "Apartment Selection", and "Security Code" screens until the "Data Transmit" screen appears. Then click the "Entry Points" button and the "Entry Point Quick Programming" screen will appear as shown to the right. To start, select whether the **ES-3** to be programmed is a low or high group (shunt selectable), enter the rotary switch position, and click "Get Status".

If a "Network Error" is given, check that the Group Shunt and Rotary Switch assignment match an actual installed **ES-3**, the **ES-3** being programmed is powered up, and the CAN bus connections are polarity correct (H & L). When all is OK, the existing parameters such as Facility Code (see Access Cards section C below), relay activation times and alarm conditions will appear. New values may be entered and applied, or click the "Guide" button to walk through detailed programming instructions in the software itself.

After one **ES-3** is programmed, select the next **ES-3** to be programmed and continue until all entry points have been programmed.

Entry Point Quick Programming

File Help

Entry Point

Low Group  High Group  Rotary Switch

Shown are the existing settings for this Entry Point. You may either change then apply new values for these settings or walk through the programming guide to set up this Entry Point.

Facility Codes accepted at this Entry Point

Note: Leave all entries '0' to allow any or all facility codes

Relay 1 (Door Strike) Activation Time  Seconds

Relay 2 Delay Time (After Relay 1 Activate)  Seconds

Relay 2 Activation Time  Seconds

Door Ajar Delay Time  Seconds

Relay 3 (Alarm) Activation Time  1 Second  Continuous

Forced Door Entry Alarm  Enabled

## C. Access Cards

26-bit Wiegand Proximity Access Cards, such as the Viking **PRX-C**, **PRX-C-ISO** and **PRX-FOB** (see **DOD# 198**), identify themselves with an eight digit number. The first three digits are considered the Facility Code and are programmed into the **ES-3**. The last five digits are the Internal Card Number and are programmed into the **AES-2000/AES-2005** as the "Keyless Entry Code" for the person the card will be issued.

**For example:** If the facility code is **477** and the Internal Card Number is **00023**, then program **477** as one of the Facility Codes in each **ES-3** entry point to be used. The Internal Card Number "**00023**" must be programmed in to **AES-2000/AES-2005** as the Keyless Entry Code for the given apartment. See the **Programming** section in the **AES-2000/AES-2005** Technical Practice.

## D. Creating Zones

Each **ES-3** entry point can be programmed to accept up to 8 different Facility Codes. In this manner, different groups of users can be issued access cards with different Facility Codes to create entry points in which some groups are allowed access, and/or other groups are not. This open form of creating "Zones" means each Entry Point can be its own unique zone.

**Note:** If all Facility Codes are left set to "0", the entry point will disregard the Facility Code all together, thus making access entry based only on a Card Number match from the Keyless Code programmed in the **AES-2000/AES-2005**.

## Operation

The **ES-3** Entry System Access Controller monitors the Wiegand device (ie. proximity card reader) for 26 bit Wiegand data. When data is received, it is converted into CAN data and sent (up to 1 mile away) to the built-in **AES-NET** network interface through the shared CAN two wire pair. The **AES-2000/AES-2005** compares the data against its programmed data base and communicates back to the originating **ES-3** whether access is granted or not. If access is granted, Relay 1 and Relay 2 will activate per their programmed delay and activation times. The Entry Point Location, time, and Card Number will all be logged in the **AES-2000/AES-2005**. Relay 1 operates first and should be used to operate the door strike or magnetic lock. Relay 2 can be delayed from Relay 1 to operate a gate / door opener, or a second door strike or magnetic lock for double entrance doors. Relay 2 may also be programmed with longer times to operate courtesy lights or a camera.

If a "Push to Open" button, push bar switch, or motion sensor activates the Request to Exit input of the **ES-3**, the relays will activate the same as if access is granted. No data is logged on a Request to Exit event.

If a door sensor switch is wired to the Door Sensor input of the **ES-3** and the door remains open longer than the programmed Door is Ajar timer, Relay 3 will activate for either 1 second or until the door closes (programmable). This can be used to set an alarm, light a security panel lamp, turn on a camera, etc.

If both a request to exit device and a door sensor switch are used, a Forced Door alarm condition may be selected. If the door is opened other than by the **ES-3**, Relay 3 will activate for either 1 second or until the door closes (programmable).

LED's are provided for the 2 inputs and the 3 relay outputs. Each LED is located behind its associated screw terminals. The LEDs will remain off showing the idle state, and turn on when its associated input/output is triggered/activated.

## Related Products

### Apartment Entry System with Accessibility Features

The **AES-2000** Accessible Entry System provides both audio and visual assistance for those with disabilities. Model **AES-2005** also features a built-in video camera.

The LCD display with large 1/2" tall characters is back-lit and will display a directory of tenants as well as directions and prompts. A built in voice recorder and announcer can also provide a supporting audio message. When the EZ™ Access button is pressed, instructions on how to use the system are both displayed and announced.

The built in directory can support up to 525 tenant names and phone numbers and will dial a pre-programmed phone number upon selection of a tenant. Once two-way communication has been established, the tenant can activate a remote door strike by entering a Touch Tone command. A second relay is also provided to operate an automatic door. The **AES-2000/AES-2005** will also support keyless entry at the door via its built-in keypad, or by adding proximity card readers, such as the **Viking PRX-1, PRX-2, PRX-3** or **PRX-4**.



**AES-2000S**  
Surface Mount

The units are available in flush mount and surface mount. For more information on the **AES-2000** see **DOD# 202**, for the **AES-2005** see **DOD# 204**. **Note:** These units requires a **PB-100** for programming.



### 125KHz Proximity Card Reader

The model **PRX-1** is a 125KHz proximity card reader and is designed to be mounted directly to a metal door or window frame (mullions), making it ideal for applications requiring an access credential. The proximity card reader transmits data in 26-Bit Wiegand format, making it compatible with any of the Wiegand equipped Viking entry controllers.

The **PRX-1** delivers non-contact read ranges up to 6 inches (152 mm), and operates from 5 to 14 VDC. Physical size is a compact 3.2 x 1.7 x 0.70 inches (80 x 43 x 17 mm). Mounting is simplified with horizontal and vertical mounting slots, which allow the reader to be conveniently adjusted and leveled. To allow both indoor and outdoor operation the electronics are sealed in tamper resistant epoxy potting. Concealing the mounting hardware, the **PRX-1** ships with both Black and Ash (Off-White) covers standard. See **DOD# 221** for more info.

### 125KHz Proximity Carder with Built-In Keypad



The model **PRX-2** is designed to be mounted directly to standard single-gang wall box, and integrates both a 125KHz proximity card reader and keypad into a single-unit making it ideal for applications requiring an access credential and/or personal identification number (PIN).

The proximity card reader and keypad of the **PRX-2** both transmit data in 26-Bit Wiegand format, making it compatible with any of the Wiegand equipped Viking entry controllers. The keypad is based upon cutting-edge, non-mechanical, capacitive technology, which, unlike membrane keypads, includes no moving parts prone to early failure. Advanced keypad enhancements include fully potted circuit board (EWP), keys with blue LED backlighting, raised key outlines and pip on the 5-key.

The **PRX-2** delivers non-contact read ranges up to 6 inches (152 mm), and operates from 5 to 14 VDC. To allow both indoor and outdoor operation the electronics are sealed in tamper resistant epoxy potting. Concealing the mounting hardware, the **PRX-2** ships with both Black and Ash (Off-White) covers standard. See **DOD# 219** for more information.



### Medium Range 125KHz Proximity Card Reader

The model **PRX-3** is a high performance medium range 125KHz proximity card reader. The **PRX-3's** compact size yet long read range of up to 16 inches\* make it ideal for parking control, gate access, turnstiles, etc. It is designed to be mounted directly to a wall, post, single gang electrical box or use an optional mounting kit (see models below) for attaching it to a gooseneck pedestal. Mounting is simplified with horizontal and vertical mounting slots, which allow the reader to be conveniently adjusted and leveled. To increase vandal resistance the chassis is a single piece design with the mounting screws concealed behind a UV stable label.

The proximity card reader transmits data in 26-Bit Wiegand format, making it compatible with any of the Wiegand equipped Viking entry controllers. The **PRX-3** is equipped with Enhanced Weather Protection (EWP) for outdoor installations where the unit is exposed to precipitation or condensation. With its sealed connections and fully potted electronics the **PRX-3** is designed to meet an IP66 Ingress Protection Rating. For more information see **DOD# 228**.



### 26-Bit Wiegand Keypad for Entry Systems

The **PRX-4** Keypad with Wiegand output allows keyless entry for select Viking apartment or office entry systems. The **PRX-4** Keypad features standard 26-bit Wiegand interfacing, a metal enclosure with potted electronics and a pigtail connection for indoor or outdoor applications.

The Keypad interfaces with the **AES-2000** Accessible Entry System. Up to 32 entry points with **PRX-4** Keypads may be added to the **AES-2000** by adding **ES-3** Controllers.

Alternatively, the **PRX-4** can be used with the **ES-1** Stand Alone Door Entry Controller, and the **C-4000** Four Door Entry Controller.

The **PRX-4** is equipped with Enhanced Weather Protection (EWP) for outdoor installations where the unit is exposed to precipitation or condensation. The **PRX-4** features a foam rubber gasket, sealed connections, as well as an epoxy potted circuit board. For more information, see **DOD# 199**.

**Product Support Line...715.386.8666**

**Fax Back Line...715.386.4345**

Due to the dynamic nature of the product design, the information contained in this document is subject to change without notice. Viking Electronics, and its affiliates and/or subsidiaries assume no responsibility for errors and omissions contained in this information. Revisions of this document or new editions of it may be issued to incorporate such changes.

