

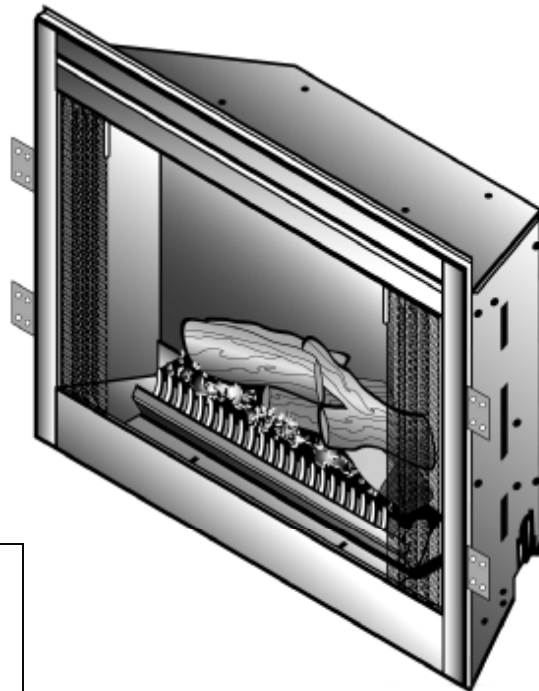

**NORTH AMERICA LIMITED**

**PRACTICAL USER'S GUIDE  
FOR THE  
OPTIFLAME ELECTRIC FIREPLACE**



Write Your Remote  
Control Code Number  
Here:

Quality checked by:

*Valued Customer,*

*We are pleased that you have chosen to purchase an electric fireplace manufactured by Dimplex North America Ltd.*

*Over the years, valuable memories will occur around the warmth and comfort of your hearth. Thank you for allowing our product to be the backdrop for those special moments.*

---

## **QUICK REFERENCE GUIDE**

### **FOR THE OPTIFLAME ELECTRIC FIREPLACE**

- 1. Prior to the first use of the fireplace verify the following:**
  - Are the circuit breakers for the fireplace on?**
  - Are the light bulbs in your fireplace loose? (to check, follow the instructions for replacing the light bulbs under the maintenance section of this manual)**
- 2. The heater on your fireplace may emit a slight, harmless odor when first used. This odor is a normal condition caused by the initial heating of internal heater parts and will not occur again.**
- 3. If your heater does not emit heat, ensure the large switch is on, that the first two red indicator lights are on (for BF36E both switches on the unit should be on and there are no red indicator lights), the wall thermostat is set above the current room temperature and any wall switches for the unit are on. If this does not work, switch the unit off for 5 minutes and try again. Consult operation section of your practical users guide for further information.**
- 4. The information regarding the model of your fireplace can be found on the rating plate located under the logs in the lighting area.**
- 5. If you have any technical questions, questions regarding the operation of your fireplace , or require service for your fireplace contact Dimplex North America customer service at 1-888-DIMPLEX (1-888-346-7539).**

---

## **CONTENTS**

PAGE

1	IMPORTANT INSTRUCTIONS
2	OPERATION
5	MAINTENANCE
7	WARRANTY AND ACCESSORIES

# IMPORTANT INSTRUCTIONS

## PLEASE RETAIN THIS USER'S GUIDE FOR FUTURE REFERENCE

When using electrical appliances, basic precautions should always be followed to reduce the risk of fire, electric shock, and injury to persons, including the following:

1. Read all instructions before using this fireplace.
2. This fireplace is hot when in use. To avoid burns, do not let bare skin touch hot surfaces. The trim around the heater outlet becomes hot during heater operation. Keep combustible materials, such as furniture, pillows, bedding, papers, clothes, and curtains at least 3 feet (0.9m) from the front of the unit.
3. Extreme caution is necessary when any heater is used by or near children or invalids and whenever the fireplace is left operating and unattended.
4. Do not operate any fireplace if the heater has malfunctioned, or if the fireplace has been dropped or damaged in any manner.
5. Do not use outdoors
6. This fireplace is not intended for use in bathrooms, laundry areas and similar indoor locations.
7. Do not insert or allow foreign objects to enter any ventilation or exhaust opening as this may cause an electric shock or fire, or damage to the heater.
8. To prevent a possible fire, do not block air intake or exhaust in any manner.
9. All electrical heaters have hot and arcing or sparking parts inside. Do not use in areas where gasoline, paint, or flammable liquids are used or stored or where the unit will be exposed to flammable vapors.
10. Do not modify this fireplace. Use it only as described in this manual. Any other use not recommended by the manufacturer may cause fire, electric shock or injury to persons.
11. Do not burn wood or other materials in this fireplace.
12. Do not strike fireplace glass.
13. Always use a certified electrician for installation.
14. Disconnect all power coming to fireplace at main service panel before performing any cleaning, or maintenance.
15. When transporting or storing the fireplace, keep in a dry place, free from excessive vibration and store as to avoid damage.

---

**NOTE:** Procedures and techniques that are considered important enough to emphasize.

**CAUTION:** Procedures and techniques which, if not carefully followed, will result in damage to the equipment.

**WARNING:** Procedures and techniques which, if not carefully followed, will expose the user to the risk of fire, serious injury, illness or death.

---

## OPERATION

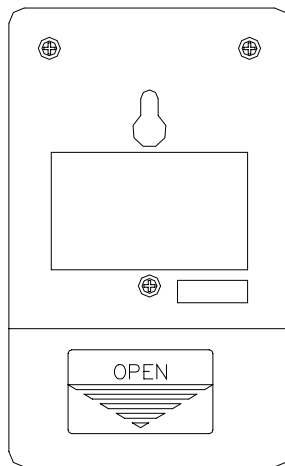
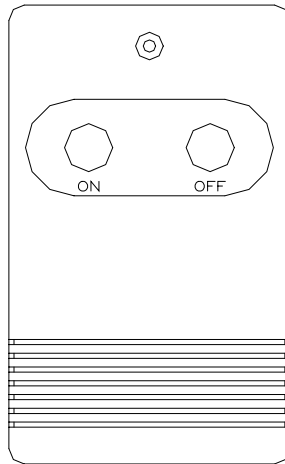

FIGURE 1

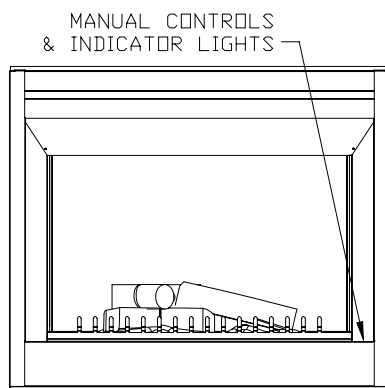

FIGURE 2

## REMOTE CONTROL

The Optiflame fireplace is supplied with a radio frequency remote control (all models except BF36E). This remote control has a range of approximately 50ft. (15.25m), it does not have to be pointed at the fireplace and can pass through most obstacles (including walls). It is supplied with one of 243 independent frequencies to prevent interference with other units. The frequency designation is indicated on the back of the transmitter (FIGURE 1).

### A. Remote Control Initialization

This procedure is required every time there is a loss of power to the remote control in the fireplace (i.e. power failure, breaker tripped, main power switch is turned off)

1. Ensure that power is supplied through main service panel.
2. Access the manual controls, (remove glass doors if applicable) pull right hand edge of right hand steel curtain towards the center of unit. (FIGURE 2)
3. Locate manual controls refer to FIGURE 3.
4. Activate main power switch, red indicator light 1 will flash.
5. Press and hold the heater control switch for five seconds. The second red indicator light will flash.
6. Press ON button located on the remote control transmitter (FIGURE 1). This will synchronize the remote control transmitter and receiver.

### B. Remote Control Usage

The remote control operates the fireplace levels sequentially. The level is increased every time the ON button on the transmitter is pressed. The fireplace can be turned off at any point by pressing the OFF button on the remote control transmitter.

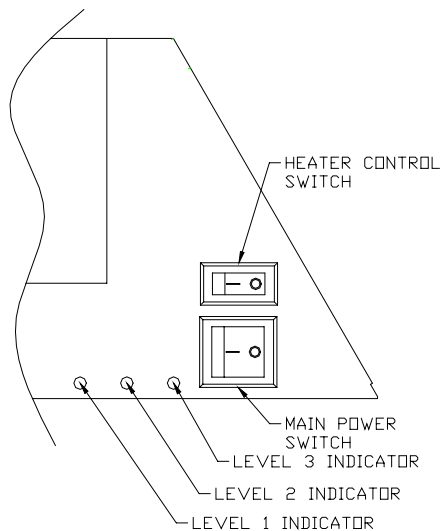

FIGURE 3

Level 1: The flame effect is turned on and the first red indicator light is activated.

Level 2: The flame effect remains on, the heater is activated to the low heat setting, and the first and second red indicator lights are activated.

Level 3: The flame effect remains on, the heater is set to the high heat setting, and all three red indicator lights are activated.

## MANUAL CONTROLS

The fireplace can also be controlled in a similar manner to the remote control with switches located on the fireplace (FIGURE3).

### A. Main Power Switch

ALL MODELS WITH REMOTE CONTROL.

Main on/off switch, supplies power to the remote control receiving unit. When placed in the on position level 1 indicator will flash.

ALL MODELS WITHOUT REMOTE CONTROL.

Main on/off switch, activates the flame effect.

### B. Heater Control Switch

ALL MODELS WITH REMOTE CONTROL.

Operates fireplace in the same manner as the remote control transmitter. Pressing the left side of this switch has the same effect as the ON button on the remote control and the right side has the same effect as the OFF button of the remote control. Pressing once to the left activates Level 1, twice activates Level 2, three times activates Level 3. Pressing to the right turns the fireplace off.

ALL MODELS WITHOUT REMOTE CONTROL.

Heater ON/OFF switch, activates heater to high level.

## **WALL MOUNTED CONTROLS**

The fireplace can be installed with wall-mounted controls in addition to the controls provided. These controls include wall switches and thermostats.

### **A. Wall Mounted Thermostats**

ALL MODELS WITH REMOTE CONTROL.

When the fireplace is set to Level 2, or Level 3 the wall mounted thermostat will control the heat output of the unit. When the fireplace is set to Level 2, or 3 the heater will not activate until the wall mounted thermostat senses an ambient temperature lower than the temperature to which it is set.

### **B. Wall Mounted Switches**

ALL MODELS WITHOUT REMOTE CONTROL ONLY.

This model may be installed such that a wall-mounted switch activates the flame effect and a wall mounted thermostat activates the heater.

## **RESETTING THE TEMPERATURE CUTOUT SWITCH**

The heater on this fireplace is protected with a safety device to prevent overheating. Should the heater overheat, an automatic cut out will turn the heater off and it will not come back on without being reset. It can be reset by switching the Main Power switch (FIGURE 3) to OFF and waiting 5 minutes before switching it to ON. The remote control will need to be re-initialized (see page 2)

### **CAUTION**

- If you need to continuously reset the heater, disconnect the power at the main service panel and call your local dealer.

### **NOTE**

- The heater may emit a slight, harmless odor when first used. This odor is a normal condition caused by initial heating of internal heater parts and will not occur again.

---

## MAINTENANCE

### WARNING

- Disconnect all power coming to fireplace at main service panel before attempting any maintenance or cleaning to reduce risk of fire, electric shock or damage to

### Light Bulb Replacement:

### NOTE

- Allow at least 5 minutes for light bulbs to cool off before touching bulbs to avoid accidental burning of skin.

Light bulbs need to be replaced when you notice a dark section of the flame or when the clarity. There are four bulbs under the log set which generate the flames and embers.

**Tool Requirements:** Slot Screw Driver

**Bulb Requirements:** Quantity of 4 clear chandelier or candelabra bulbs with an E-12 (small) socket base, 60 watt rating. Example: GE 60BC or Philips 60CTC.

### CAUTION

- Do not exceed 60 watts per bulb.
- When handling log only apply force to the ember bed section not directly to the logs.

### Helpful Hints

It is a good idea to replace all light bulbs at one time if they are close to the end of their rated life. Group replacement will reduce the number of times you need to open the unit to replace light bulbs. Long life bulbs are recommended to reduce the frequency of bulb changes.



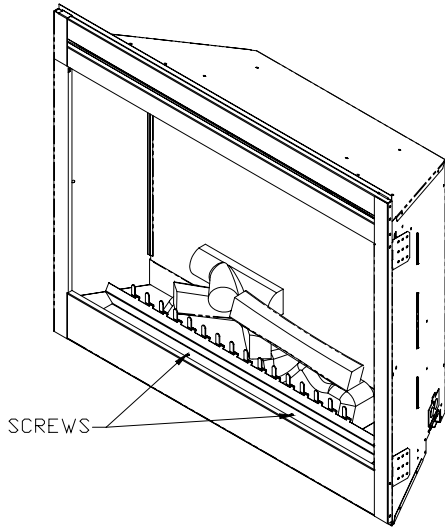

FIGURE 4

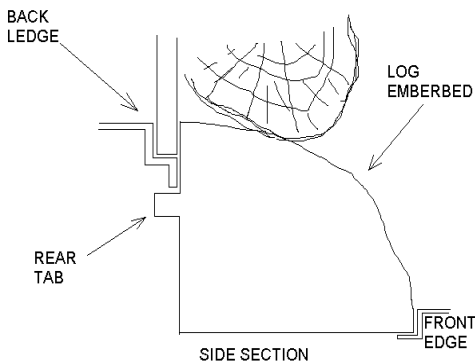

FIGURE 5

**To access the light bulb area:**

1. Open steel curtain (remove glass doors if applicable).
2. Remove two screws on log grate and remove log grate (FIGURE 4).
3. Pull rear edge of ember bed up and forward by grasping ember bed by the sides (handle the logset only by the emberbed and not the logs) and pulling solidly until the rear tab pops out from under the back ledge, then lift out. (FIGURE 5)
4. Examine the bulbs to determine which bulbs require replacement.
5. Unscrew bulbs counter clockwise.
6. Insert new bulbs.
7. Replace the log by inserting front edge and pushing the back down until rear tab snaps under back ledge (FIGURE 5) and the logs are resting against mirror.
8. Replace log grate using two screws previously removed.

**Mirror Cleaning:**

The mirror is cleaned in the factory during the assembly operation. During shipment, installation, handling, etc., the mirror surface may collect dust particles; these can be removed by buffing lightly with a clean dry cloth.

To remove fingerprints or other marks, the mirror can be cleaned with a damp cloth using good quality household glass cleaner. The mirror should be completely dried with a lint free cloth or paper towel.

**CAUTION**

- Do not use abrasive cleaners on mirror surface or spray liquids directly onto any surface.

## WARRANTY

Dimplex Optiflame Electric Fireplaces are tested and inspected prior to shipment and are guaranteed from defect to the purchaser of each new product. Any part which proves to be defective in material or workmanship under normal use within one year will be repaired or replaced without charge.\* The Company will not be responsible for any expense incurred for installation, removal from service, or transportation costs. Any such defect should be brought to the attention of the Dealer where the product was purchased and is authorized to repair or replace within the terms of this warranty.

The Company's only obligation under this warranty will be at its sole option to repair or replace any part proving defective or to refund the purchase price thereof.

The owner/user assumes all other risks, if any, including the risk of any direct, indirect or consequential loss or damage arising out of the use of or inability to use the product.

The warranty will not apply if, in the sole judgement of the Company, damage or failure has resulted from accident, alteration, misuse, abuse, incorrect installation, or operation on an incorrect power source. Dimplex requires that all electric fireplace products are to be field serviced when ever possible.

Dimplex electric fireplaces are covered by a free in home service for the period that the fireplace is under warranty. For service call 1-888-DIMPLEX (1-888-346-7539)

The foregoing is in lieu of all other warranties expressed, implied, or statutory, and the Company neither assumes, nor authorizes any person to assume for it any other obligation, or liability in connection with said product.

\*Light bulbs are not covered in the warranty.

---

## ACCESSORIES

Please contact your local dealer for genuine Dimplex accessories. Example: Glass door kits, brass trim, cabinets designed to fit your Optiflame fireplace.

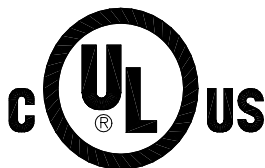

1-888-DIMPLEX  
1-888-346-7539

 **Dimplex**  
NORTH AMERICA LIMITED

1367 Industrial Road  
Cambridge, Ontario  
Canada, N1R 7G8

Approved for use in the United States and Canada