



MA45CD

ORDERCODE D6103



SHOWELECTRONICS FOR PROFESSIONALS

Congratulations!

You have bought a great, innovative product from DAP Audio.

The Dap Audio MA45CD brings excitement to any venue. Whether you want simple plug-&-play action or a sophisticated show, this product provides the effect you need.

You can rely on DAP Audio, for more excellent audio products.

We design and manufacture professional sound equipment for the entertainment industry.

New products are being launched regularly. We work hard to keep you, our customer, satisfied.

For more information: iwant@dap-audio.info

You can get some of the best quality, best priced products on the market from DAP Audio.

So next time, turn to DAP Audio for more great sound equipment.

Always get the best -- with DAP Audio !

Thank you!



Dap Audio

Dap Audio MA45CD™ Product Guide

Warning	2
Safety-instructions.....	2
Operating Determinations.....	3
Description	4
Features Frontside.....	4
Backside.....	5
Installation	5
Set Up and Operation	5
Operations CD Player	7
Set Up Example 1+2.....	10
Connection Cables	12
Maintenance	13
Troubleshooting	13
Product Specifications	15

WARNING



**FOR YOUR OWN SAFETY, PLEASE READ THIS USER MANUAL CAREFULLY
BEFORE YOUR INITIAL START-UP!**

SAFETY INSTRUCTIONS

Every person involved with the installation, operation and maintenance of this device has to:

- be qualified
- follow the instructions of this manual



Before your initial start-up, please make sure that there is no damage caused by transportation. Should there be any, consult your dealer and do not use the device.

To maintain perfect condition and to ensure a safe operation, it is absolutely necessary for the user to follow the safety instructions and warning notes written in this manual.

Please consider that damages caused by manual modifications to the device are not subject to warranty.

This device contains no user-serviceable parts. Refer servicing to qualified technicians only.

IMPORTANT:

The manufacturer will not accept liability for any resulting damages caused by the non-observance of this manual or any unauthorized modification to the device.

- Never let the power-cord come into contact with other cables! Handle the power-cord and all connections with the mains with particular caution!
- Never remove warning or informative labels from the unit.
- Do not open the device and do not modify the device.
- Do not insert objects into air vents.
- Do not connect this device to a dimmerpack.
- Do not switch the device on and off in short intervals, as this would reduce the system's life.
- Only use device indoor, avoid contact with water or other liquids.
- Avoid flames and do not put close to flammable liquids or gases.
- Always disconnect power from the mains, when device is not used or before cleaning! Only handle the power-cord by the plug. Never pull out the plug by tugging the power-cord.
- Make sure that the available voltage is not higher than stated on the rear panel.
- Make sure that the power-cord is never crimped or damaged. Check the device and the power-cord from time to time.
- Never use anything to cover the ground contact.
- Make sure that there is sufficient room on all sides of the system for air circulation.
- Avoid ground loops! Always be sure to connect the power amps and the mixing console to the same electrical circuit to ensure the same phase!
- Please turn off the power switch, when changing the power cord or signal cable.

- Make sure that the amplifier is turned down, before turning the power on or off. So you can avoid supersonic frequencies, which could damage your speakers.
- Don't put your equipment next to TV, radio, etc., because of interference or distortion.
- If you connect other parts of the system, be careful of ground loops.
- The best way to avoid ground loops is connecting the electrical system ground to one central point ("star" system). In this case the mixer can act as a central point.
- To prevent humming, please try different combinations of ground-lift or connect all chassis to the system ground, either by a power cable or frontcover rack screws.
- Before changing the ground, always turn off your amplifier.
- Please read this manual carefully and keep it for future reference. Remember that the amplifier has a better value on the market, if you save the carton and all packing materials.
- Prevent distortion! Make sure that all components connected to the MA45CD have sufficient power ratings. Otherwise distortion will be generated because the components are operated at their limits.
- Make sure you don't use the wrong kind of cables or defective cables.
- Make sure that signals into the mixer are balanced, otherwise hum could be created.
- If device is dropped or struck, disconnect mains power supply immediately. Have a qualified engineer inspect for safety before operating.
- If the device has been exposed to drastic temperature fluctuation (e.g. after transportation), do not switch it on immediately. The arising condensation water might damage your device. Leave the device switched off until it has reached room temperature.
- If your Dap Audio device fails to work properly, discontinue use immediately. Pack the unit securely (preferably in the original packing material), and return it to your Dap Audio dealer for service.
- Allow time to cool down, before cleaning or servicing.
- For replacement use fuses of same type and rating only.
- This device falls under protection class I. Therefore it is essential to connect the yellow/green conductor to earth.
- Repairs, servicing and electric connection must be carried out by a qualified technician.
- WARRANTY: Till one year after date of purchase.

OPERATING DETERMINATIONS

This device is not designed for permanent operation. Consistent operation breaks will ensure that the device will serve you for a long time without defects.

If this device is operated in any other way, than the one described in this manual, the product may suffer damages and the warranty becomes void.

Any other operation may lead to dangers like short-circuit, burns, electric shock, lamp explosion, crash etc. You endanger your own safety and the safety of others!

Improper installation can cause serious damage to people and property !

Description of the device

Features

The MA45CD is an amplifier from DAP Audio.

- 2 unbalanced 6.3 mm jack inputs mic sensitivity
- 1 unbalanced 6.3 mm jack input Mic/Aux
- Final stages completely protected thermal shut down and short protection.
Dual power supply in alternating current (AC 115V or 230V) power supply in direct current (DC 12V)
- Output level LED indicator
- CD player with MP3

Overview



Fig. 1

1) CD Player with MP3

2+3) Bass + Treble : These are used to adjust equalization level for this amplifier. Turning the knobs in clockwise direction will increase LOW (HIGH)-frequencies, turning the knobs in a counter-clockwise direction will decrease LOW (HIGH)-frequencies.

4) Siren On/Off

5) Mic 1 volume control: Adjust the mic output volume level

6) Mic 2 volume control: Adjust the mic output volume level

7) Mic3/AUX volume control: Adjust the Mic/Aux output volume level

8) Mic3/Aux Input Sensitivity Switch: Switch between the mic level and the line level

9) Mic 1 Phone Jack: This MIC input jacks is a 6.3mm (1/4") unbalanced jack input, specifically designed for a dynamic microphone.

10) Mic 2 Phone Jack: This MIC input jacks is a 6.3mm (1/4") unbalanced jack input, specifically designed for a dynamic microphone.

11) Mic3 / AUX Phone Jack: The AUX input jack is a 6.3mm (1/4") unbalanced jack. You can connect audio From HiFi-VCRs, cassette and reel-to-reel tape decks, DAT machines, CD players, Laser discs, tuners, even synthesizers or other mixing consoles

12) Ouput Level meter: For proper operation of the amplifier keep the correct volume setting

13) AC Power On/Off

14) Power LED

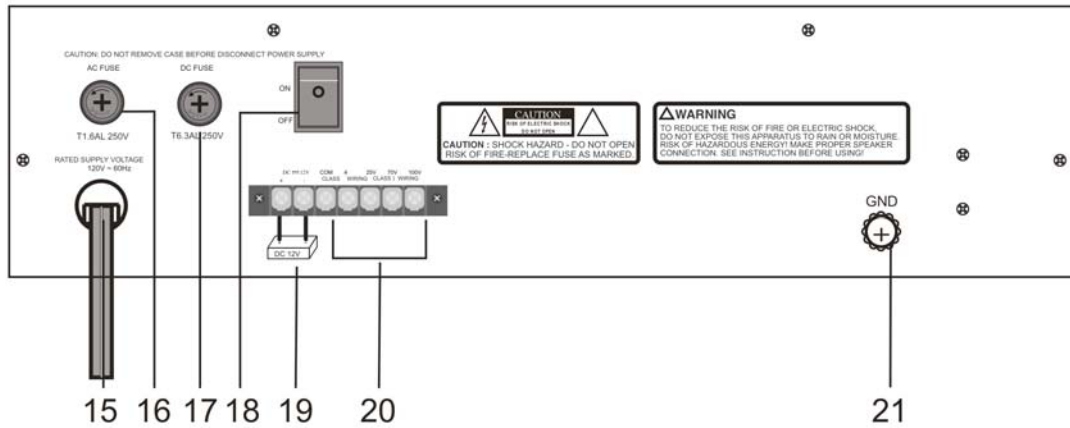

Fig. 2

- 15) AC Input 230V
- 16) AC Fuse 0,8A
- 17) DC Fuse 6,3A
- 18) DC Power On/Off
- 19) DC Input 12V
- 20) Output terminals: connect to the speakers
- 21) Ground (GND) screw

Installation

MA45CD Installation

Remove all packing materials. Check that all foam and plastic padding has been removed. If you want to use the amplifier in a 19" Rack, you must first install the 19" flaps. Then screw the amplifier/CD player in a 19" Rack. Connect all cables.

Always disconnect from electric mains power supply before cleaning or servicing.

Damages caused by non-observance are not subject to warranty.

Set Up and Operation

Before plugging the unit in, always make sure that the power supply matches the product specification voltage. Do not attempt to operate a 120V specification product on 240V power, or vice versa. Do not supply power before all components of the system are set up and connected properly.

DC power or battery supply's connection

- The unit will also operate with an external 12V battery or another source with negative (-) as ground. Power connection is made at the DC terminal strip on the rear panel.
- If the AC power supply fails, transfer to DC power is instantaneous, automatic and silent.
- The battery power supply is operated by the primary switch.
- The amplifier is not capable of recharging the connected battery. Thus, it is recommended to have a suitable device at hand. When the amplifier is on the DC power source, the nominal power handling capacity operated drops by approximately 20%.

Input Connection

Microphones

The MA45CD is equipped with 3 inputs. They can be used with unbalanced low impedance devices

MIC-1, MIC-2

These two microphone inputs are unbalanced type and are provided with a double pole phone jack.

Balanced LO Z Microphone

May also be connected to the unbalanced input

We advise you to use FL0215, FL023 or FL026 unbalanced mic cables from Dap Audio

Priority paging:

The amplifier features a transistorized circuit, which automatically mutes the other inputs and allows microphone #1 to talk over for special or emergency announcements. This electronic switch is operated from the microphone, which must contain a single-pole switch, normally open for actuating this circuit.

Operations CD Player

1. Opening and closing of the disc holder

- Turn the unit's power on. Press the OPEN/CLOSE-button to open the disc holder.
- The disc holder cannot be opened during playback, to prevent playback from being interrupted if the OPEN/CLOSE button is pressed accidentally. Stop the playback first, then press the OPEN/CLOSE button.

2. Loading CD's

- Hold the disc by the edges and place it in the disc holder, then press the OPEN/CLOSE button to close the holder.

CAUTION:

- Do not place any foreign objects in the disc holder and do not place more than one disc in the disc holder at a time.
- Do not push the disc holder in manually when the power is off, as this may result in malfunction and damages the player.

3. Selecting Tracks

- Press the SKIP-button to move to next higher or lower track.
- Hold the SKIP button to change tracks continuously at a higher speed.
- When a new track is selected during playback, playback begins as soon as the skip search operation is completed.
- If the Skip-button ►► is pressed while at the last track, the first track is selected. In the same way, If the Skip- button ◀◀ is pressed while at the first track, the last track is selected.

4. Starting Playback

- Press the PLAY/PAUSE button to start playback when you've just loaded a new CD or press the PLAY/PAUSE during the pause condition to restart playback.

5. Playback stoppen

There are two ways to stop playback:

- 1). Press the PLAY/PAUSE button during playback to pause at that point.
- 2). Press the STOP button during playback.

6. Pausing

- Press the PLAY/PAUSE button to switch between play and pause.

7. Program Play

1. Press the PROGRAM button, the player will enter the program mode.
2. Select the desired track by pressing the SKIP button, then press the PROGRAM button again. The selected track will be added to the program sequence.
3. Repeat step 2 operation. A maximum of 20 tracks can be programmed at one time.
4. Press the PLAY/PAUSE button to start the program play from the first selection.
5. Press the program button again during program play to stop playing.
6. Press and hold the program button more than 2 seconds to cancel the program mode and erase all the current program contents.

8. Repeat

1. Press the REPEAT button, the player will repeat the song, which is playing at the moment.

Before switching off the power

When you have finished using the CD player, before switching off the power, be sure that the disc holder has been closed with the OPEN/CLOSE button.

CAUTION: Do not forcibly close the disc holder when the power is off.

CD's

1. Precautions on handling compact discs

- Do not allow fingerprints, oil or dust to get on the surface of the disc. If the disc is dirty, wipe it off with a soft dry cloth.
- Do not use benzene, thinner, water, record spray, electrostatic-proof chemicals, or silicone-treated cloths to clean discs.
- Always handle discs carefully to prevent damaging the surface; in particular when removing a disc from its case or returning it.
- Do not bend the disc.
- Do not put the CD near heating sources.
- Do not enlarge the hole in the center of the disc.
- Do not write on the label (printed side) with a hard-tipped implement such as a pencil or ball point pen.
- Condensation will form if a disc is brought into a warm area from a colder one, such as outdoors in winter. Do not attempt to dry the disc with a hair dryer, etc.

2. Precaution on storage

- After playing a disc, always unload it from the player.
- Always store the disc in the jewel case to protect from dirt or damage.
- Do not place discs in the following areas:
 1. Areas exposed to face sunlight for a considerable time.
 2. Areas subject to accumulation of dust or high humidity.
 3. Areas are affected by heat from indoor heaters, etc.

CD function buttons

 CD power switch with two-position for ON-OFF mode, before press it, please turn off the volume knob.

 OPEN/CLOSE: press to open/close the disc holder

 PLAY/PAUSE: when press the button, the CD player will start playing; press the same button again and the CD player will pause.

LEVEL: this control allows you to adjust the CD volume.

 STOP: the CD player will stop playing.

 B.SKIP/REW: the CD player will Skip backwards.

 F.SKIP/FF: the CD player will Skip forwards.

"REPEAT": the CD player will keep repeating the same song. Press the button again and the CD player will repeat the entire CD; if you press it again, the CD player will return to its normal condition of playing.

"PROG": the CD player can setup in accordance with you favoured selections.

NOTE: Before you press the ON button, be sure to that the volume control is set to its minimum.

Low Impedance Speaker Output: 4Ω

The low impedance 4Ω terminal is for connecting of a few large-output speakers, when constant-voltage speaker systems are unnecessary or the distance between the amplifier and the speakers is below 50m. The total speaker load impedance must be matched to the output impedance (4Ω) of the amplifier for the most efficient power-transfer.

Be sure that total impedance of speakers is above 4Ω however; do not raise the amplifier's output power above the allowable input power of the speaker. If the amplifier's output power should be raised above the maximum, the speakers could be damaged.

LOW IMPEDANCE OUTPUT

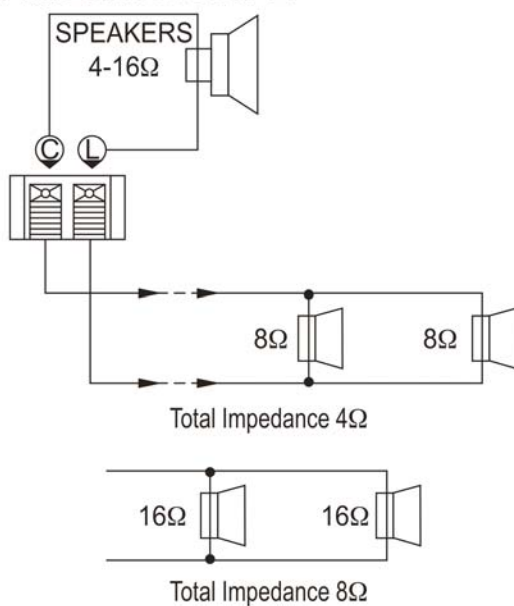

Fig. 3

Connection Input

The balanced phone jack inputs have a nominal impedance of 20 KΩ (10KΩ with unbalanced wiring) and will accept the line level output of most devices. The correct input depends on 2 factors: (1) whether the input signals are balanced or unbalanced, and (2) whether the signal source floats or has ground reference. Figures provide examples of recommended connection techniques for each type of signal source. The optional connector is shown.

Set Up Example 1

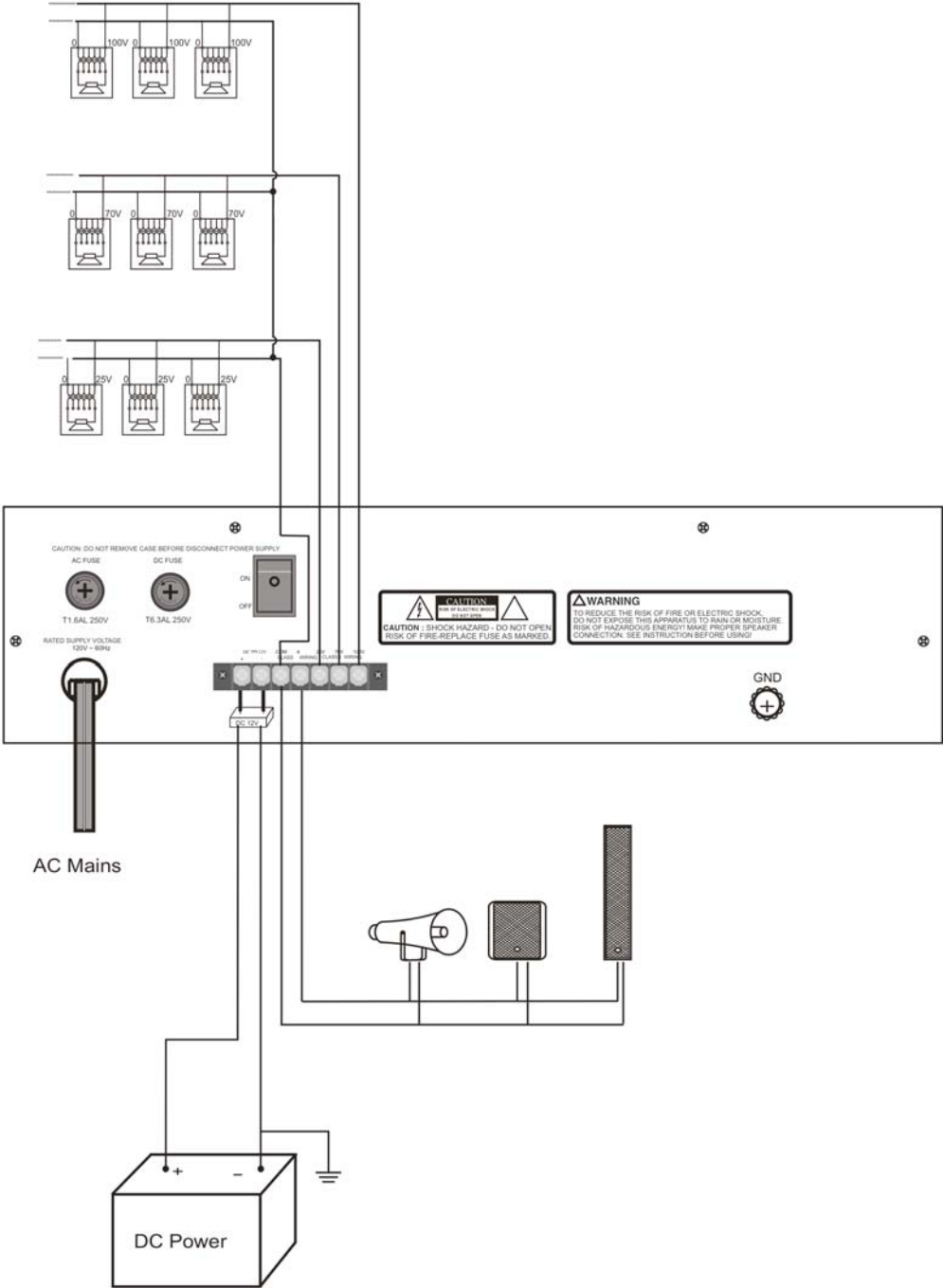

Fig. 4

Set Up Example 2

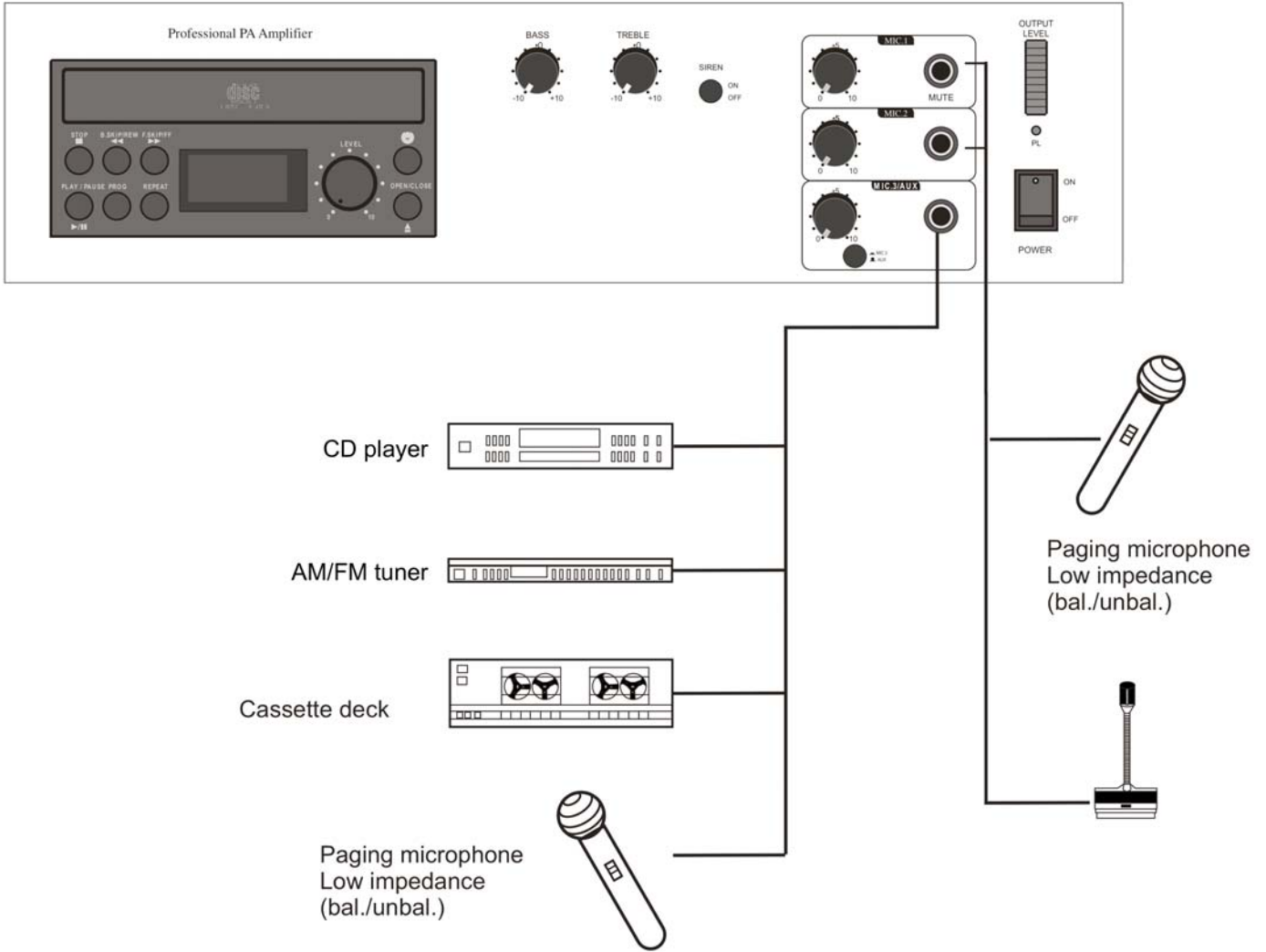

Fig. 5

Connection Cables

Take care of the connector cables, always holding them by the connectors and avoiding knots and twists when coiling them: This gives the advantage of increasing their life and reliability, which is always to your advantage.

Periodically check that your cables are in good condition, that they are correctly wired and that all their contacts are perfectly efficient: a great number of problems (faulty contacts, ground hum, discharges, etc.) are caused entirely by using unsuitable or faulty cables.

Headphones

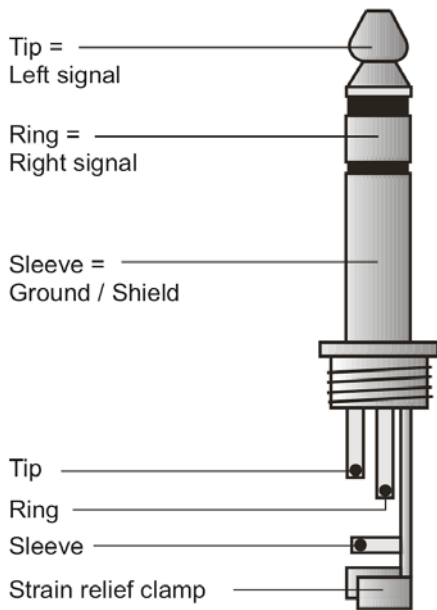

Unbalanced mono 1/4" jack plug

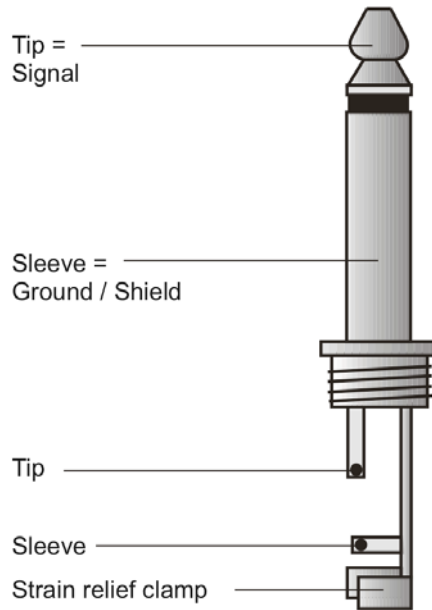

Balanced mono 1/4" jack plug

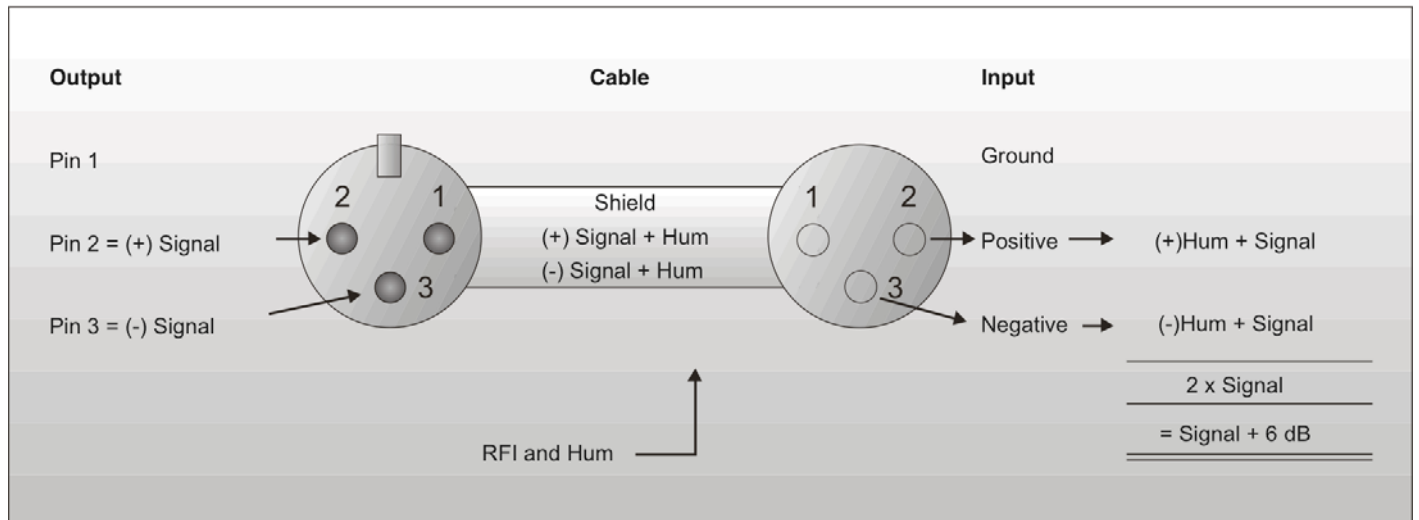
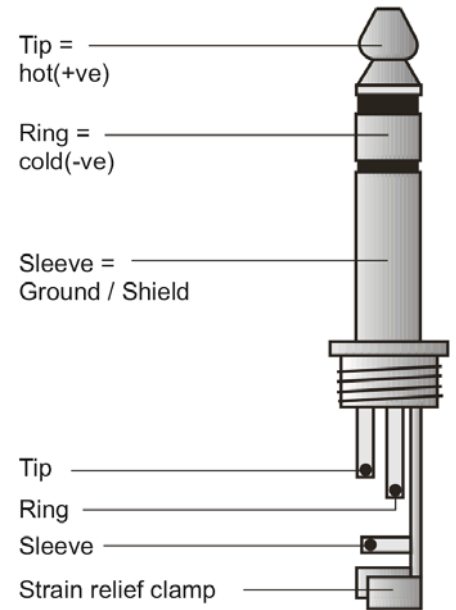

Compensation of interference with balanced connections

Balanced use with XLR connectors

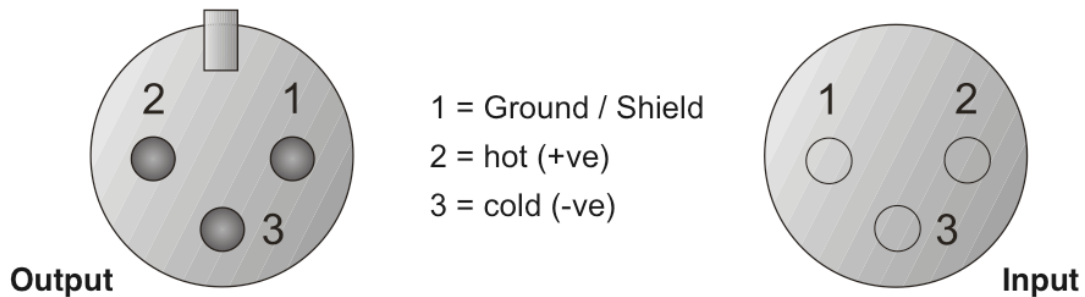

For unbalanced use PIN 1 and PIN 3 have to be bridged

Maintenance

The Dap Audio MA45CD requires almost no maintenance. However, you should keep the unit clean. Disconnect the mains power supply, and then wipe the cover with a damp cloth. Do not immerse in liquid. Do not use alcohol or solvents.

Keep connections clean. Disconnect electric power, and then wipe the audio connections with a damp cloth. Make sure connections are thoroughly dry before linking equipment or supplying electric power.

Troubleshooting

DAP Audio MA45CD

This troubleshooting guide is meant to help solve simple problems.

If a problem occurs, carry out the steps below in sequence until a solution is found. Once the unit operates properly, do not carry out following steps.

1. If you experience low output or no output at all, unplug the amplifier immediately.
2. Check power from the wall, all cables, the fuse, etc.
3. If all of the above appears to be O.K., plug the unit in again.
4. If nothing happens after 30 seconds, turn off the amplifier and unplug the device.
5. Return the machine to your DAP Audio dealer.

Problem	Cause	Solution
No lights illuminates when the POWER button is pressed.	1.Is the unit plugged into a live outlet? 2.Was the AC fuse opened? 3.Was the DC fuse opened?	1.Load outlet 2.Replace AC fuse 3.Replace DC fuse
No sound is heard	1.Check if the audio source was connected? 2.Was the audio source operating? 3.Is the volume turned up? 4.Are the speakers connected properly?	1.Connect to audio source output. 2.Operate the audio source. 3.Turn up the volume. 4.Correctly connect speakers.
The unit's output is intermittent or continuously buzzing	Check if the AC power supply is correct	
No output from one or more channels	1.Is the audio source operating? 2.Is the volume turned up? 3.Are the cables not defective?	1.Operate the audio source. 2.Turn up the volume. 3.Replace the signal cable.
Fuse often blown	1.Was the volume turned to full? 2.Were the speakers connected correctly? 3.Were the wires of the speaker connected correctly? 4.Is the impedance of the speakers correct? 5.Is the speaker good?	1.Turn down the level volume. 2.Connect the speaker correctly. 3.Connect the speaker wires correctly. 4.Connect the matching output terminal or replace with the matching impedance. 5.Replace the speaker.
No display of CD player or Radio	Is the CD player or Radio power switch turned on?	Turn on the power switch.
No output of the CD player	1. Is the volume turned up? 2. Is the CD player paused?	1. Turn up the CD volume 2. Press the PLAY/PAUSE again.
The CD player doesn't react to any key control and the display is not functioning properly.	1.Is the rated voltage correct ? 2.Did you frequently turn the CD power switch on/off?	1.Change the rated power voltage into the right one 2.Turn the CD power off and after 10 seconds turn it on again
The radio can't store a radio station in its memory	Was the memory store operation correct	Reset it, according to the correct operating and procedure
The radio can't receive a radio station	1.Is the antenna connection correct? 2.is the unit placed in the right position?	1.Connect the antenna correctly. 2.Adjust the position of the unit. Or extend the antenna correctly
Overload LED keeps blinking	1.Is the connection of the output terminal ok? 2.Is the connected load too heavy? 3. Is the input signal too loud?	1.Connect the speakers to the proper output terminal. 2.Reduce the total load and keep the impedance matching. 3. Adjust the signal level control

Product Specifications

Model: DAP Audio MA45CD

Power consumption: 110W

DC Power consumption: 40W

Power Supply: AC or DC 12V

Power Output: RMS 45W

Output terminal block: Low impedance: 4~16Ω

High voltage: 50V, 70V, 100V

Input sensitivity: Mic 1-3: - 52dB ± 1 dB

AUX: - 20dB ± 2 dB

Inputs: MIC-1, MIC-2, MIC-3 (-52dB) 10 KΩ

AUX (-20dB) 50 KΩ

THD (AUX Input 1kHz): < 1.0%

Signal-to-Noise ratio (Input 1kHz, rated output): Mic 1-3 >52dB rated power

AUX >63 dB rated power

Frequency response (load 4 Ohm, output 2V, -3dB): Mic 1-3: 30~15kHz

AUX: 30~25kHz

Tone control: Bass: ± 10dB at 100 Hz

Treble: ± 10dB at 10 KHz

Alarm function: Siren

Controls: Mic 1, Mic 2, Mic 3/AUX Volume control

CD volume control

Bass and Treble Control

Mic 3/Aux switch and 2 power switches

Indicator: Power LED, Digital Display for CD player, LED Output Level indicator

Dimensions : 400 x 305 x 100 mm (LxWxH)

Weight : 7,7 kg

Design and product specifications are subject to change without prior notice.





© 2005 DapAudio.