

Machine Overview

- 1 Handle
- 2 On/off switch
- 3 Brushbar on/off indicator
- 4 Battery charge indicator
- 5 Battery slot
- 6 Dirt container
- 7 Floor head
- 8 Dirt container release button
- 9 Filter cap
- 10 Filter
- 11 Separator
- 12 Quick release button
- 13 Floor head removal button

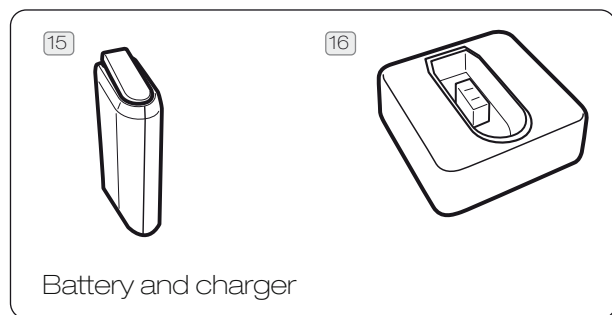
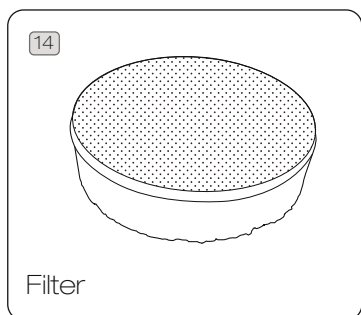
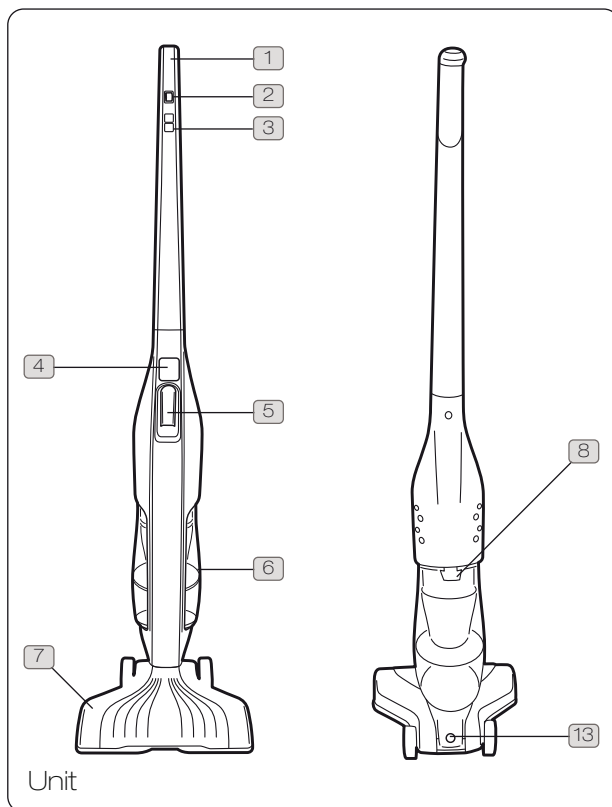
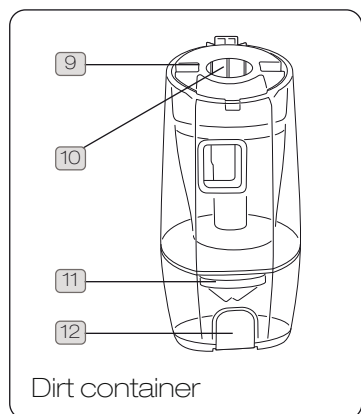

14 Foam filter

15 Lithium-Ion battery

16 Battery charger

General Safety Information

FOR HOUSEHOLD USE ONLY.

When using the cordless upright vacuum cleaner, basic safety precautions should always be observed, including the following:

1. Do not charge outdoors.
2. Turn off the vacuum cleaner control before removing or replacing the battery.
3. Children should be supervised to ensure that they do not play with the appliance.
4. This appliance is not intended for use by persons (including children) with reduced physical, sensory or mental capabilities, or lack of experience and knowledge, unless they have been given supervision or instruction concerning use of the appliance by person responsible for their safety.
5. Use only as described in this manual.
6. Do not use charger with damaged cord or plug. If the appliance is not working, as it should, has been dropped damaged, left outdoors, or dropped into water, return it to a Vax Authorised Service Agent or suitably qualified person for examination, repair or adjustment, simply call us on AU: 1300 361 505 / NZ: 0800 800 900
7. Do not abuse the charger cord. Keep the charger cord away from heated surface. Do not pull the charger cord around sharp edges or corners. Do not close the charger cord in a door.
8. Do not handle the plug or appliance with wet hands.
9. This product uses a rechargeable Lithium-Ion battery. Do not throw the battery into fire or expose to high temperatures, as it may burst.
10. Do not use with any opening blocked; keep free of dust, lint, hair, and anything that may reduce airflow.
11. Keep hair, loose clothing, fingers and all parts of the body away from openings and moving parts.
12. Do not pick up hot coals, cigarette butts, matches or anything hot, smoking or burning objects.
13. Do not pick up flammable or combustible materials (lighter fluid, petrol, kerosene, etc) or use in the presence of explosive liquids or vapour.
14. Do not vacuum up harmful or toxic material (chlorine bleach, ammonia, drain cleaner, etc).
15. Do not use without the filter in place.
16. Do not vacuum up hard or sharp objects such as glass, nails, screws, coins, etc.
17. Take extra care when cleaning on stairs
18. Store the appliance indoors in a cool, dry area.
19. Use only the charger supplied by the manufacturer to recharge.
20. Do not continuously leave the charger connected to the mains when not in use.



IMPORTANT: For dry debris use only.



WARNING: Always switch off and remove the battery from the vacuum before assembling, opening or emptying the dirt container.

Battery Recycling

Your cleaner uses a Lithium-Ion battery. When these batteries no longer recharge, they must be removed from the cleaner and disposed of properly.



IMPORTANT: The battery is to be disposed of in one piece. Do not attempt to take apart.

If you would like information on the correct disposal of batteries, we're here to help. Simply call us on AU: 1300 361 505 / NZ: 0800 800 900.

This cordless upright vacuum cleaner is intended for household use only and NOT for commercial or industrial use.

PLEASE KEEP INSTRUCTIONS FOR FURTHER USE.

Operation

Keep your Vax like new

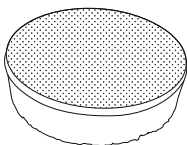

! **IMPORTANT:** The condition of the filters affects the performance of your machine. Please check and clean filters periodically (depending on the level of use). For full cleaning instructions, see page 6.

! **IMPORTANT:** Do not use the vacuum cleaner without all of the filters in place.

Assembling your vacuum cleaner

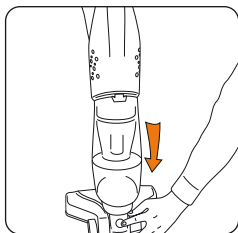

Line up floor head with main body and firmly push together until floor head locks into place.

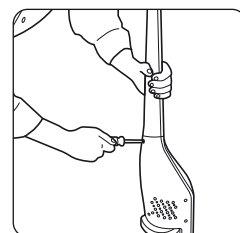
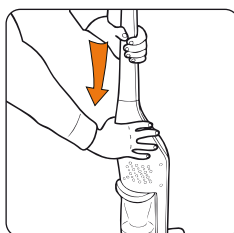

NOTE: Do not over-tighten screw.

Operating the appliance

NOTE: Fully charge battery before first use.

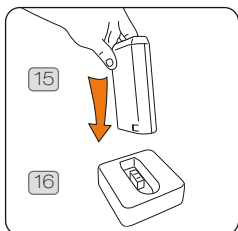

Plug charger into the mains. Push down firmly. LED indicator will light within 2 seconds if inserted properly. Ensure the initial charge is 3 hours.

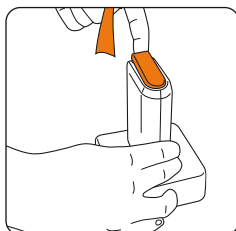

To remove battery, pull up release flap while holding the charger.

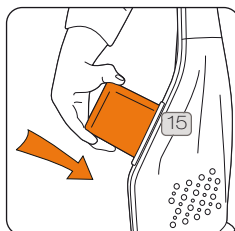

NOTE: Make sure on/off switch on machine is set to off.

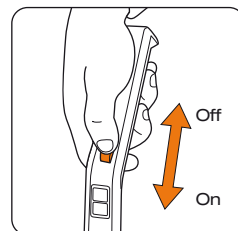

On/off switch:
 0 Off
 I Hard floors
 II Carpets

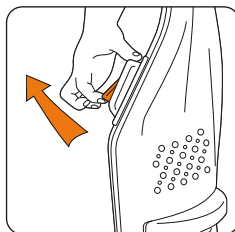
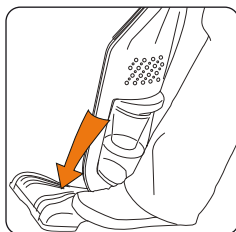

! **IMPORTANT:** Do not use brushbar on hard floors as it may cause damage.

Operation

Machine: battery charge indicator

All three LEDs will light momentarily when the power switch is turned on. The battery charge indicator will then indicate remaining capacity as below:

3 LEDs lit	Remaining capacity is more than 75%
2 LEDs lit	Remaining capacity is more than 50%
1 LED lit	Remaining capacity is more than 25%
1 LED blinking	Remaining capacity is less than 25%

Charger: LED operations

LED not lit, battery not in charger	No charging is taking place	Normal condition
LED lit continuously	Battery is charging	Leave battery in charger
LED pulses (gradually dimming and brightening)	Battery is fully charged	Remove battery from charger

Battery recycling

Your cleaner uses a Lithium-Ion battery. When these batteries no longer recharge, they must be removed from the cleaner and recycled.



IMPORTANT: The battery is to be disposed of in one piece. Do not attempt to take apart.

If you would like information on the correct disposal of batteries, we're here to help. Simply call us on AU: 1300 361 505 / NZ: 0800 800 900.

Maintenance (Keep your Vax as good as new)

Emptying and cleaning the dirt container

! **IMPORTANT:** Turn the vacuum cleaner off and remove the battery pack before performing maintenance/troubleshooting checks.

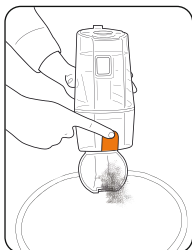
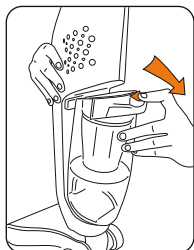

Cleaning the filter

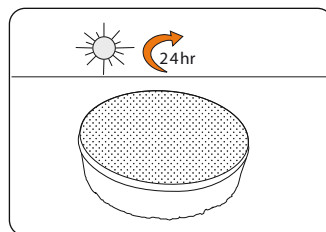
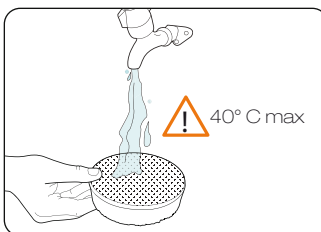
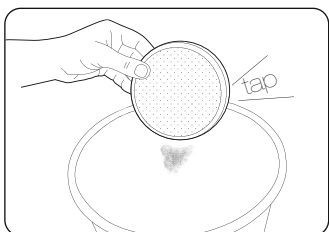
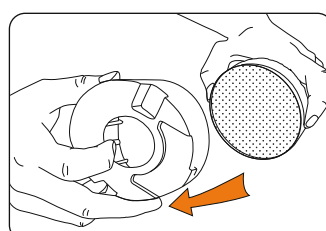
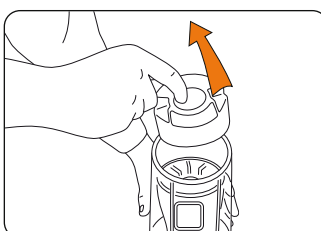
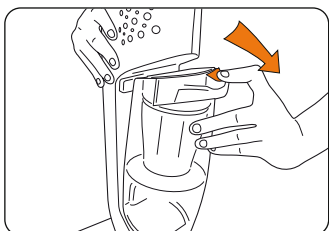

Maintenance (Keep your Vax as good as new)

Removing blockages

! **IMPORTANT:** Turn the vacuum cleaner off and remove the battery pack before performing maintenance/troubleshooting checks.

Removing debris from the brushbar

Remove screws as indicated on floor head plate. Lift plate to access brushbar and belt.

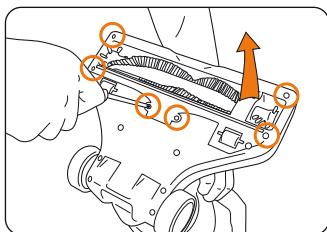

Using a pair of scissors, cut through any threads or hairs caught around the brushbar.

Removing debris from the air path

Remove the floor head by pressing the floor head release button on the base of the unit, and pulling in a downward motion. Remove any blockages and reassemble the unit.

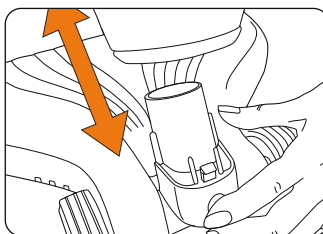
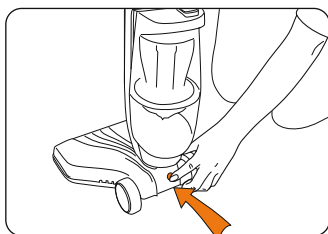

FAQs (Unit)



WARNING: to reduce the risk of personal injury, remove battery pack before performing maintenance/troubleshooting checks.

Why won't the vacuum turn on?

- Check the battery is inserted correctly into the product (Page 5).
- The battery might not be charged; remove and charge battery.
- Battery might be too hot; remove and let cool for 30 minutes. Replace battery.
- For further assistance, please call us on:
AU: 1300 361 505 / NZ: 0800 800 900

Why does the product turn off while in use?

- The battery might be discharged; remove and charge battery.
- Battery might be too hot; remove and let cool for 30 minutes. Replace battery.
- For further assistance, please call us on:
AU: 1300 361 505 / NZ: 0800 800 900

Why won't the vacuum pick up properly?

- The dirt container may be full; refer to Emptying and Cleaning the Dirt Container (Page 6).
- The dirt container may be incorrectly installed; remove the dirt container from the unit by pressing the dirt container release button (Page 6) and reattach it to the unit, ensuring it is locked firmly back into place.
- The filters may be clogged; refer to Cleaning the Filter (Page 6).
- The separator may be clogged; refer to Advanced Cleaning (Page 6).
- The air path or brushbar may be blocked; refer to Removing Blockages (Page 7).
- For further assistance, please call us on:
AU: 1300 361 505 / NZ: 0800 800 900

Why isn't my brushbar rotating?

- The brushbar may not be turned on; refer to Operation (Page 4).
- The brushbar may be blocked; refer to Removing Blockages (Page 7).

FAQs (Battery and charger)



WARNING: to reduce the risk of personal injury, remove battery pack before performing maintenance/troubleshooting checks.

Why isn't the LED lit when the battery is inserted into the charger?

- Check that the wall charger is plugged in.
- Check the battery is inserted correctly into the charger (Page 5).
- The battery may not be communicating with the charger. Remove battery and unplug charger, wait 10 seconds, then plug charger into socket and re-insert battery.
- For further assistance, please call us on:
AU: 1300 361 505 / NZ: 0800 800 900

Why does the LED flash twice followed by a 1 second off period?

- The battery might be too hot or cold. Leave the battery in the charger. When the battery reaches the correct temperature, the battery will start charging automatically.

Why is the LED continually flashing?

- Check the battery is inserted correctly into the charger (Page 5).
- The battery or charger may have detected an error. Remove battery and unplug charger, wait 10 seconds, then plug charger into socket and re-insert battery.
- For further assistance, please call us on:
AU: 1300 361 505 / NZ: 0800 800 900

Why does the LED flash/stay lit after battery is removed?

- This is normal if within 10 seconds of battery removal.
- If it still flashes after 10 seconds, unplug charger, wait 10 seconds, then plug charger into socket.
- For further assistance, please call us on:
AU: 1300 361 505 / NZ: 0800 800 900

Other Information

Service & Help

Vax Customer Service line AU: 1300 361 505 / NZ: 0800 800 900

Monday-Friday 8.30am to 5.30pm

If you have any queries about using your Vax, call the Vax Careline. Calls are charged at the standard national rate.

Please make a note of the serial number and model number of the carpet cleaner before calling or visit www.vax.com.au

Technical Specification

Battery type:	Lithium-ion
Battery voltage:	18V
Capacity:	1L
Runtime:	Brushbar on - 12 mins Brushbar off - 13 mins
Weight:	3.4kg
Charger input wattage:	220 - 240V - 50Hz
Charging time:	3 hours
Filter type:	Washable

Subject to technical change without notice.

Distributed by Techtronic Industries, Australia.
666 Doncaster Rd,
Doncaster 3108.



Waste electrical products should not be disposed of with household waste. Please recycle where facilities exist. Check with your Local Authority or retailer for recycling advice.

Notes



