

# Cub Cadet

## Operator's Manual

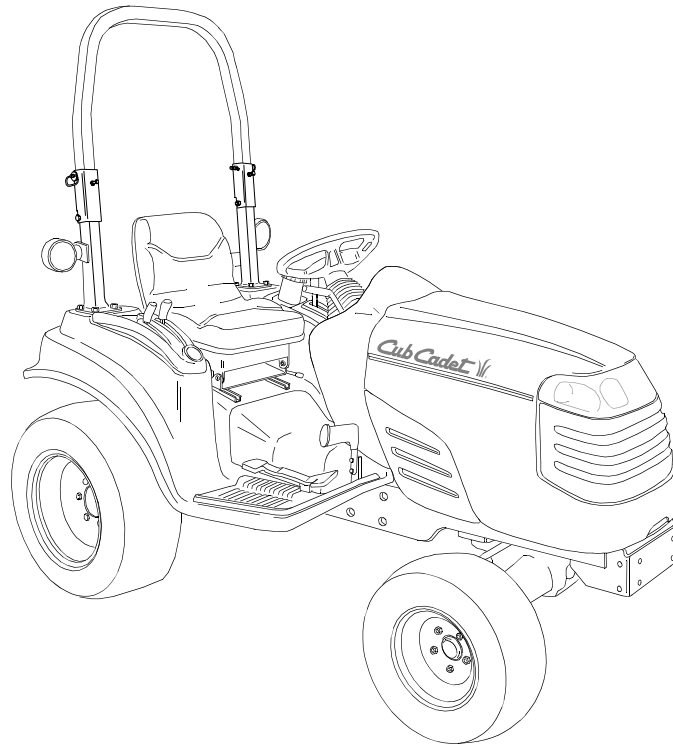

## SERIES 7000 COMPACT TRACTOR MODEL 7264

### IMPORTANT: READ SAFETY RULES AND INSTRUCTIONS CAREFULLY

**Warning:** This unit is equipped with an internal combustion engine and should not be used on or near any unimproved forest-covered, brush-covered or grass-covered land unless the engine's exhaust system is equipped with a spark arrester meeting applicable local or state laws (if any). If a spark arrester is used, it should be maintained in effective working order by the operator. In the State of California the above is required by law (Section 4442 of the California Public Resources Code). Other states may have similar laws. Federal laws apply on federal lands. A spark arrester for the muffler is available through your nearest engine authorized service dealer or contact the service department, P.O. Box 361131 Cleveland, Ohio 44136-0019.

**CUB CADET LLC P.O. BOX 361131 CLEVELAND, OHIO 44136-0019 [www.cubcadet.com]**

PRINTED IN U.S.A.  
ECO 11781

FORM NO. 769-00002A  
(10/02)

---

## TABLE OF CONTENTS

TO THE OWNER .....	2
CALLING SERVICE INFORMATION .....	2
RECORDING MODEL AND SERIAL NUMBER INFORMATION .....	3
IMPORTANT SAFE OPERATION PRACTICES .....	4
SAFETY LABELS .....	7
SECTION 1: CONTROLS AND FEATURES .....	9
SECTION 2: OPERATION .....	15
SECTION 3: ADJUSTMENTS .....	24
SECTION 4: TRACTOR MAINTENANCE .....	27
SECTION 5: ENGINE INFORMATION AND MAINTENANCE .....	41
SECTION 6: SPECIFICATIONS .....	49
SECTION 7: OPTIONAL EQUIPMENT AND ACCESSORIES .....	51
WARRANTY .....	52

---

## TO THE OWNER

This Operator's Manual is an important part of your new tractor. The information contained in this manual has been prepared in detail to help you better understand the features, correct operation, adjustments, and maintenance of your tractor. The performance and dependability of this tractor rely greatly on the manner in which it is operated and maintained. Therefore, it is recommended that all operators of the tractor carefully read this manual and fully understand its operation. Also keep the manual available for reference to ensure proper operation, and that maintenance procedures are performed as scheduled to assure the tractor's optimal mechanical condition.

**NOTE:** *All references to LEFT, RIGHT, FRONT, and REAR, unless specifically stated otherwise, indicate that relative position on the tractor when facing forward while seated in the operator's seat.*

Your authorized *Cub Cadet* dealer is interested in the performance you receive from your tractor, and with the maintenance needed to ensure the satisfactory operation of your tractor. The dealer has trained service personnel familiar with the latest servicing information, is equipped with the latest tools, and has a complete line of genuine *Cub Cadet* service parts which assure proper fit and high quality.

---

## CALLING SERVICE INFORMATION

The engine manufacturer is responsible for all engine-related issues with regards to performance, power-rating, and specifications.

If you have difficulties with the tractor and/or equipment; have any questions regarding the operation or maintenance of this equipment; or desire additional information not found in this manual, contact your dealer. If you need assistance in locating a dealer in your area, contact the Customer Dealer Referral Line by calling:

**1-877-282-8684**

Before calling your dealer, make sure that you have your model number(s) and manufacturing date available for the dealer.



---

## IMPORTANT SAFE OPERATION PRACTICES



**WARNING:** THIS SYMBOL POINTS OUT IMPORTANT SAFETY INSTRUCTIONS WHICH, IF NOT FOLLOWED, COULD ENDANGER THE PERSONAL SAFETY AND/OR PROPERTY OF YOURSELF AND OTHERS. READ AND FOLLOW ALL INSTRUCTIONS IN THIS MANUAL BEFORE ATTEMPTING TO OPERATE YOUR UNIT. FAILURE TO COMPLY WITH THESE INSTRUCTIONS MAY RESULT IN PERSONAL INJURY. WHEN YOU SEE THIS SYMBOL, HEED ITS WARNING.



**WARNING:** The engine exhaust, some of its constituents, and certain vehicle components contain or emit chemicals known to the State of California to cause cancer, birth defects or other reproductive harm.



**DANGER:** Your tractor was built to be operated according to the rules for safe operation in this manual. As with any type of power equipment, carelessness or error on the part of the operator can result in serious injury. To help prevent accidents, read and take the following precautions before operating this tractor. Failure to observe the following safety instructions could result in serious injury or death.

### 1. GENERAL OPERATION

- Read, understand, and follow all instructions in the operator's manual and on the machine before starting. Keep this manual in a safe place for future and regular reference.
- Only allow responsible individuals familiar with the instructions to operate the machine. Know controls and how to stop the machine quickly.
- Use the roll bar and seat belt for safe operation. Overturning the tractor without a roll bar, or with a roll bar and the seat belt unfastened, can result in death or injury.
- Always use the seat belt, except if the roll bar has been removed or, if applicable, the roll bar is in the folded position.
- Use the handholds and running boards when getting on and off the tractor to help prevent accidental falls. Keep the running boards clear of mud and debris.
- Wear sturdy, rough-soled work shoes. Never operate the tractor in bare feet, sandals, or sneakers.
- Do not wear loose fitting clothes or jewelry. They can be caught in moving parts.
- Do not allow anyone but the operator to ride on the tractor. There is no safe position on the tractor for additional riders.
- Keep all safety decals clean and readable. Replace any missing, illegible, or damaged safety decals.
- Do not operate the machine while under the influence of alcohol or drugs.
- Use only accessories approved for this machine by the manufacturer. Read, understand and follow all instructions provided with the approved accessory.
- Before starting the tractor, engage the parking brake, place the PTO switch in the "OFF" position, place the lift control lever in the down position, and make certain any remote control valve levers are in the neutral position.
- Always sit in the tractor seat when starting the engine or operating controls. Do not start the engine or operate controls while standing beside the tractor.
- Never tamper with safety devices. Check their proper operation regularly. Contact your Cub Cadet dealer if safety devices malfunction.
- Avoid accidental contact with control pedals while the engine is running, as this can cause unexpected movement of the tractor.
- Never leave a running machine unattended. Always disengage the PTO, engage the parking brake, and stop engine before dismounting.
- Never park the tractor on a steep incline.
- Pull only from a drawbar or the lower hitch links in the down position. Make certain the drawbar pin is locked in place. Pulling from the rear axle of the tractor or any point above the axle could cause the tractor to overturn.

- Maintain the weight balance of the tractor. Install front end weights to counterbalance heavy implements attached to the three point hitch. Do not operate the tractor with a light front end.
- Any towed vehicle with a total weight exceeding that of the tractor should be equipped its own braking system that is operational from the tractor seat.
- Do not leave equipment in the raised position.
- Watch for traffic when operating near or crossing roadways. If local laws permit road travel, use the flashing hazard lights and SMV signs when traveling on public roadways.
- Make certain all tractor lights are illuminated when operating at night.
- Always watch where you are going, especially at blind corners, trees, or other objects that can obscure your vision.
- Check overhead clearance carefully before driving under power lines, wires, bridges or low hanging tree branches, before entering or leaving buildings, or in any other situation where the operator and/or roll bar may be struck, which could result in serious injury.
- To avoid upsets, drive the tractor with care and at a safe speed. Use extra caution when operating over rough ground, when crossing ditches or slopes, and when turning corners.
- If the tractor becomes stuck, use reverse to free the tractor to prevent tractor upset.

## 2. SLOPE OPERATION

Slopes are a major factor related to loss of control and tip-over accidents which can result in severe injury or death. All slopes require extra caution. If you cannot back up the slope or if you feel uneasy on it, do not operate this unit on that area or serious injury could result.

### DO:

- Operate up and down slopes, not across.
- Remove obstacles such as rocks, limbs, etc.
- Watch for holes, ruts or bumps. Uneven terrain could overturn the machine. Tall grass can hide such obstacles.
- Place the transmission in the low range. when climbing or descending slopes. Always keep machine in gear when going down slopes to take advantage of engine braking action.
- Follow the manufacturers recommendations for counterweights to improve stability.

- Keep all movement on the slopes slow and gradual. Do not make sudden changes in speed or direction. Rapid engagement or braking could cause the front of the machine to lift and rapidly flip over backwards which could cause serious injury.
- Avoid starting or stopping on a slope. If tires lose traction, disengage the PTO and proceed slowly straight down the slope.

### DO NOT:

- Do not turn on slopes unless necessary; then, turn slowly and gradually downhill, if possible.
- Do not mow near drop-offs, ditches or embankments. The mower could suddenly turn over if a wheel goes over the edge of a cliff or ditch, or if an edge caves in.

## 3. CHILDREN

- Tragic accidents can occur if the operator is not alert to the presence of children. Children are often attracted to the machine. Never assume children will remain where you last saw them.
- Keep children out of the operating area and in watchful care of an adult other than the operator.
- Be alert and turn machine off if children enter the area.
- Before and when backing, look behind and down for small children.
- Never carry children. They may fall off and be seriously injured or interfere with safe machine operation.
- Never allow children under 14 years old to operate the machine. Children 14 years and over should only operate machine under close parental supervision and proper instruction.
- Use extra care when approaching blind corners, shrubs, trees or other objects that may obscure your vision of a child or other hazard.
- Remove key when machine is unattended to prevent unauthorized operation.

## 4. OPERATING THE PTO

- When operating PTO driven equipment, disengage the PTO, stop the engine, and wait until the PTO stops before dismounting the tractor and disconnecting the equipment.
- Do not wear loose fitting clothing when operating the PTO or when near rotating equipment.

- To prevent injury, do not adjust, unclog, clean, or service PTO driven equipment while the tractor engine is running.
- Make certain all PTO shields are always installed.

## 5. SAFETY FRAME (ROPS)

Your tractor is equipped with a rollover protective structure (ROPS) which must be maintained in a fully functional condition. Use care when driving through doorways or spaces with a low overhead.

- Never modify the ROPS in any way.
- Never attempt to straighten or reweld any part of the main frame or retaining brackets that have been damaged. Doing so may weaken the structure and endanger your safety.
- Never secure any parts on the main frame or attach the safety frame with anything other than the special fasteners specified.
- Never attach ropes, chains, or cables to the ROPS for pulling purposes.
- Although the ROPS provides you the maximum protection possible, never take unnecessary risks.

## 6. SERVICE

- Use extreme care in handling gasoline and other fuels. They are extremely flammable and the vapors are explosive. Use only an approved container.
- Never remove fuel cap or add fuel with the engine running.
- Replace fuel cap securely and wipe off any spilled fuel before starting the engine as it may cause a fire or explosion.
- Extinguish all cigarettes, cigars, pipes and other sources of ignition.
- Never refuel the machine indoors because fuel vapors will accumulate in the area.
- Never store the fuel container or machine inside where there is an open flame or spark, such as a gas hot water heater, space heater or furnace.
- The cooling system is under pressure. Never remove the radiator cap when the system is hot. Slowly turn the cap the to the first stop to release pressure before removing the cap.

- Escaping hydraulic fluid under pressure can penetrate the skin. If fluid is injected into the skin, seek immediate medical attention. Do not use your hand to check for leaks. Use a piece of cardboard or paper.
- Never run a machine inside a closed area.
- To reduce fire hazard, keep the tractor free of any debris build-up. Clean up oil or fuel spillage.
- Before cleaning, repairing or inspecting, make certain all moving parts have stopped. Keep all nuts, bolts and screws tight to be sure the equipment is in safe working condition.
- Never tamper with safety devices. Check their proper operation regularly.
- Check brake operation frequently. Adjust and service as required.
- Engine components become hot during operation and can cause a burn. Allow to cool down before touching.
- Do not change the engine governor settings or overspeed the engine. Excessive engine speeds are dangerous.
- Observe proper disposal laws and regulations. Improper disposal of fluids and materials can harm the environment and the ecology.
- Prior to disposal, determine the proper method to dispose of waste from your local Environmental Protection Agency. Recycling centers are established to properly dispose of materials in an environmentally safe fashion.
- Use proper containers when draining fluids. Do not use food or beverage containers that may mislead someone into drinking from them. Properly dispose of the containers immediately following the draining of fluids.
- DO NOT pour oil or other fluids into the ground, down a drain or into a stream, pond, lake or other body of water. Observe Environmental Protection Agency regulations when disposing of oil, fuel, coolant, brake fluid, filters, batteries, tires and other harmful waste.
- We do not recommend the use of a pressure washer or garden hose to clean your unit. They may cause damage to electrical components; spindles; pulleys; bearings; or the engine. The use of water will result in shortened life and reduce serviceability.



**WARNING: - YOUR RESPONSIBILITY:** Restrict the use of this power machine to persons who read, understand and follow the warnings and instructions in this manual and on the machine.

# SAFETY LABELS

<p><b>STARTING INSTRUCTIONS</b></p> <ol style="list-style-type: none"> <li>1. KNOW THE OPERATING AND SAFETY INSTRUCTIONS IN THE OPERATOR'S MANUAL AND ON THE TRACTOR.</li> <li>2. MOVE THROTTLE TO MID POSITION AND DEPRESS BRAKE PEDAL.</li> <li>3. TURN KEY TO THE START POSITION.</li> </ol> <p><b>STOPPING INSTRUCTIONS</b></p> <ol style="list-style-type: none"> <li>1. DISENGAGE PTO AND SET PARKING BRAKE.</li> <li>2. MOVE THROTTLE CONTROL TO MID POSITION AND TURN KEY OFF.</li> </ol>	<p><b>IGNITION</b></p>
<p><b>⚠ WARNING</b></p> <p><b>AVOID SERIOUS INJURY OR DEATH.</b></p> <ul style="list-style-type: none"> <li>• GO UP AND DOWN SLOPES, NOT ACROSS.</li> <li>• AVOID SUDDEN TURNS.</li> <li>• DO NOT OPERATE UNIT WHERE IT COULD SLIP OR TIP.</li> <li>• IF MACHINE STOPS GOING UPHILL, STOP PTO AND BACK DOWN HILL SLOWLY.</li> <li>• DO NOT MOW WHEN CHILDREN OR OTHERS ARE AROUND.</li> <li>• DO NOT ALLOW PASSENGERS ON THE TRACTOR AT ANY TIME.</li> <li>• LOOK DOWN AND BEHIND BEFORE AND WHILE BACKING.</li> <li>• KEEP SAFETY DEVICES [GUARDS, SHIELDS, AND SWITCHES] IN PLACE AND WORKING.</li> <li>• REMOVE OBJECTS THAT COULD BE THROWN BY THE BLADES.</li> <li>• KNOW LOCATION AND FUNCTION OF ALL CONTROLS.</li> <li>• BE SURE THE BLADES AND THE ENGINE ARE STOPPED BEFORE PLACING HANDS OR FEET NEAR BLADES.</li> <li>• BEFORE LEAVING OPERATOR'S POSITION, DISENGAGE PTO, ENGAGE BRAKE LOCK, SHUT OFF ENGINE AND REMOVE KEY.</li> <li>• SLOW DOWN FOR TURNS, ROUGH GROUND AND SLOPES TO AVOID UPSET.</li> <li>• ON PUBLIC ROADS USE SMV EMBLEM AND HAZARD LIGHTS.</li> </ul> <p><b>READ OPERATOR'S MANUAL</b></p>	

**INSTRUCTION AND WARNING LABEL  
LOCATED ON RUNNING BOARD TUNNEL COVER**

**⚠ WARNING**

KEEP HANDS  
AND CLOTHING  
AWAY FROM  
ROTATING FAN  
AND BELTS TO  
PREVENT  
SERIOUS INJURY

**FAN WARNING LABEL  
LOCATED ON EACH  
SIDE OF RADIATOR**

**⚠ WARNING**

EXPLOSION AND INJURY CAN  
RESULT FROM THE USE OF  
STARTING AIDS WITH HOT GLOW  
PLUGS, DO NOT INJECT GASOLINE  
OR ETHER IN AIR INTAKE

**STARTING AID  
WARNING LABEL  
LOCATED UNDER HOOD**

---

## SAFETY LABELS (Cont.)



**PTO WARNING LABEL  
LOCATED ON REAR PTO SHIELD**

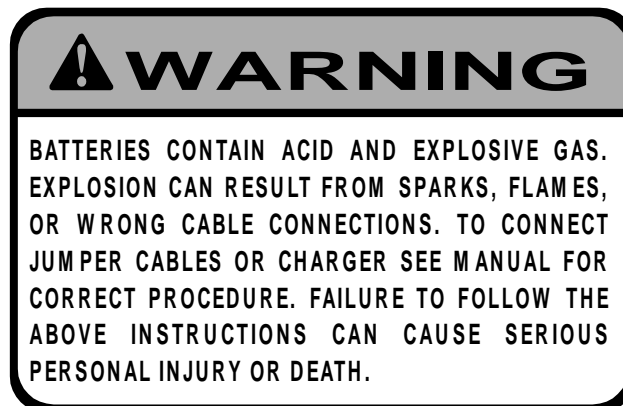

**BATTERY WARNING LABEL  
LOCATED UNDER HOOD**

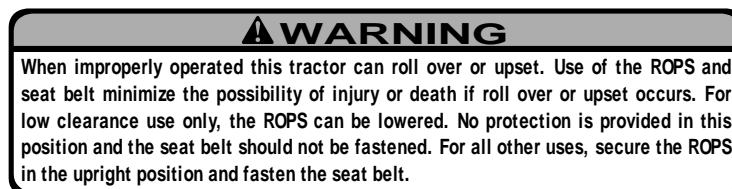

**ROLL OVER WARNING LABEL  
LOCATED ON RIGHT/REAR FENDER**



---

# SECTION 1: CONTROLS AND FEATURES

## FLOORBOARD AND DASH PANEL MOUNTED CONTROLS

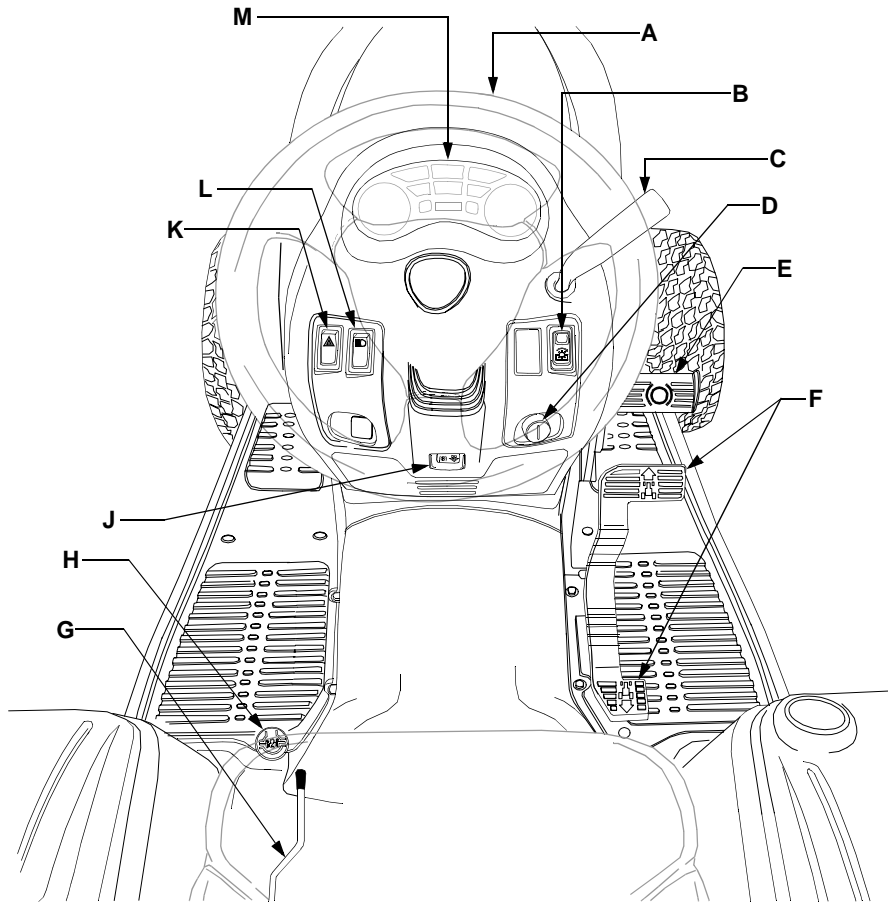

Figure 1

- |                         |                           |
|-------------------------|---------------------------|
| A Steering Wheel        | G Seat Adjustment Lever   |
| B PTO Switch            | H Differential Lock Pedal |
| C Throttle Handle       | J Parking Brake Lever     |
| D Ignition Switch       | K Hazard Light Switch     |
| E Brake Pedal           | L Headlight Switch        |
| F Forward/Reverse Pedal | M Instrument Panel        |

\* Steering Wheel and Seat Phantom For Clarity

**NOTE:** References to *LEFT* and *RIGHT* indicate that side of the tractor when facing forward while seated in the drivers seat. Reference to *FRONT* indicates the grille end of the tractor; to *REAR*, the drawbar end.

**A. Steering Wheel**

The steering wheel is centered on the dash panel. It is used to change the direction (left or right) of the tractor while driving.

**NOTE:** This tractor is equipped with hydraulic power steering. With this feature, the cap and spokes of the steering wheel may change position.

**B. PTO Switch**

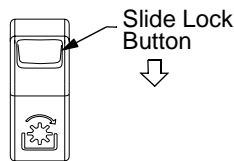

**Figure 2**

The PTO switch is a double action rocker type switch located to the right of the steering wheel on the dash panel. Slide the lock button rearward and push the *top* of the PTO switch downward to engage the PTO. Push the *bottom* of the switch downward to disengage.

**C. Throttle Handle**



This symbol indicates the fast position.



This symbol indicates the slow position.

The throttle handle is located to the right of the steering wheel on the dash panel. When set in a given position, a uniform engine speed will be maintained. Rotate the handle rearward to increase the engine speed.

**D. Ignition Switch**

**NOTE:** To prevent accidental starting and/or battery discharge, remove the key from the ignition switch when the tractor is not in use.

The ignition switch has three positions as follow:

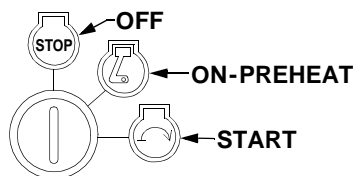

**Figure 3**

OFF - The engine and electrical system is turned off.

ON - The electrical system and glow plugs are energized.

START- The starter motor will turn the engine. Release the key immediately when the engine starts

**E. Brake Pedal**

Brake Pedal Symbol



**Figure 4**

The brake pedal is located at the front of the right floor board. Depress to engage the tractor brakes and neutralize the hydrostatic transmission. Fully depress the brake pedal to activate the safety interlock switch when starting the tractor.

**F. Forward/Reverse Pedal**

The forward/reverse pedal is a self neutralizing rocker style pedal located along the right floor board.

Forward Pedal Symbol

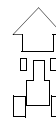

Reverse Pedal Symbol

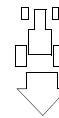

**Figure 5**

**Forward**

Slowly press down on the front of the pedal to start moving forward. The forward ground speed of the tractor is directly affected by the distance the front of the pedal is depressed.

**Reverse**



**WARNING:** Check behind the tractor to be sure the area is clear of people, pets or obstacles and use a slower speed to maintain control of the tractor when traveling in reverse.

Press down on the rear of the pedal to move in reverse.

**G. Seat Adjustment Lever**

The seat adjustment lever is located beneath the left side of the seat. This lever is used to adjust the seat forward or backward.

## H. Differential Lock Pedal

Diff. Lock  
Pedal  
Symbol

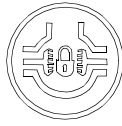

Figure 6

Located at the rear of the left floor board, the differential lock pedal engages the transmission differential lock.

The differential lock is used to gain additional traction when operating the tractor on wet or loose soil. When the pedal is depressed the rear wheels of the tractor are prevented from rotating independently of one another.



**WARNING:** When operating with the differential lock engaged, the tractor will be difficult to steer. Do not drive the tractor on roadways or at high speeds with the differential lock engaged.

**NOTE:** *Disengagement of the differential lock is recommended prior to turning the tractor on grass or other maintained surfaces — tire damage to the turf could occur.*

## J. Parking Brake Lever

Parking  
Brake  
Symbol



Figure 7

The parking brake lever is located below the steering wheel in the dash panel. With the brake pedal fully depressed, push the parking brake lever downward and release the brake pedal to lock the parking brake.

## K. Hazard Light Switch



Figure 8

The hazard light switch is a rocker type switch located to the left of the steering wheel on the dash panel. Push the *top* of the hazard light switch downward to activate the flashing amber lights.



**WARNING:** Always activate the flashing hazard lights when operating the tractor on, or near, roadways.

## L. Headlight Switch

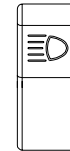

Figure 9

The headlight switch is a rocker type switch located to the left of the steering wheel on the dash panel. Push the *top* of the headlight switch downward to turn on the headlights, instrument panel lights, and tail lights.

## M. Instrument Panel

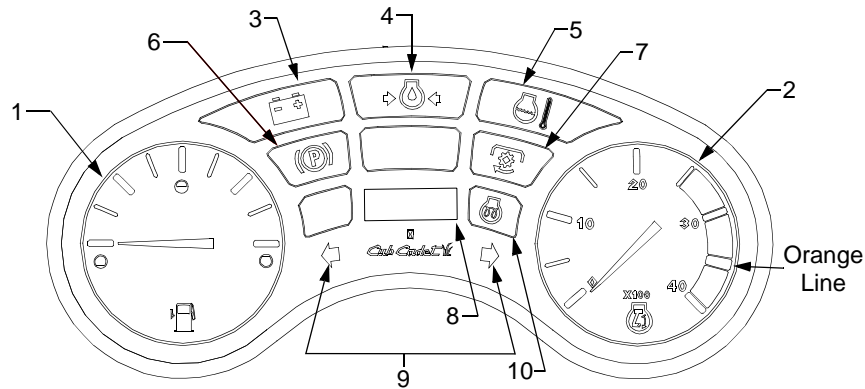

Figure 10

### 1. Fuel Gauge

The fuel gauge, located on the left side of the instrument panel, monitors the fuel level in the fuel tank. The needle pointing to the right indicates a full tank. The ignition switch must be in the ON position to read the fuel gauge.

### 2. Tachometer

The tachometer, located on the right side of the instrument panel, shows the engine speed in revolutions per minute (RPM). Optimal operating engine speed is 3500 RPM as indicated by the orange line. When operating PTO driven attachments the engine RPM indicator should be at or very near the orange line.

### 3. Battery Indicator Light

The bulb illuminates in a flashing mode to indicate the battery is being discharged. If this warning lamp comes on during operation, check the charging system for possible causes and/or contact your Cub Cadet dealer.

### 4. Engine Oil Pressure Light

The bulb illuminates when the ignition switch is in the ON position and should turn off shortly after the engine is started. Illumination of this warning lamp indicates low engine oil pressure. If the bulb comes on while the engine is running, stop the engine immediately and check for possible causes.

### 5. Engine Coolant Temperature Light

Illumination of this warning lamp indicates the temperature of the engine coolant has risen above the prescribed operating range. If the light comes on while operating the tractor, eliminate all loads and try cooling the engine by running at half throttle (Approx. 1600 to 1800 RPM) for a few minutes. Stop the engine and allow to cool; then check for possible causes (e.g. low coolant level, plugged radiator screen).

### 6. Parking Brake Indicator Light

The bulb illuminates when the ignition switch is in the ON position and the parking brake is engaged. The light flashes if attempting to start the tractor with the brake not engaged.

### 7. PTO Indicator Light

The light comes on in a **fixed** mode whenever the PTO switch is in the ON position, with the following exceptions.

- The light will illuminate in a flashing mode if attempting to start the tractor with the PTO switch in the ON position.
- The light will change to the flashing mode when the PTO switch is on, but the reverse pedal has been engaged and the reverse override has NOT been engaged

### 8. Hourmeter

The hourmeter records the hours and tenths of an hour (*right* most digit) that the tractor has been operated. The hourmeter is activated **whenever** the ignition switch is in the ON position. Keep a record of the actual hours of tractor operation to ensure all maintenance procedures are completed according to the schedule in this manual.

### 9. Hazard Light Indicator

The two arrows will flash in conjunction with the amber hazard lights when the hazard light switch is turned on.

### 10. Glow Plug Indicator Light

Illuminates when the ignition switch is turned to the ON position. The light remains lit for a preset time while the glow plugs heat the precombustion chambers of the diesel engine.

**NOTE:** By design, some of the instrument panel lights will momentarily remain lit after the ignition switch has been turned to the OFF position.

## FENDER MOUNTED CONRTOLS AND FEATURES

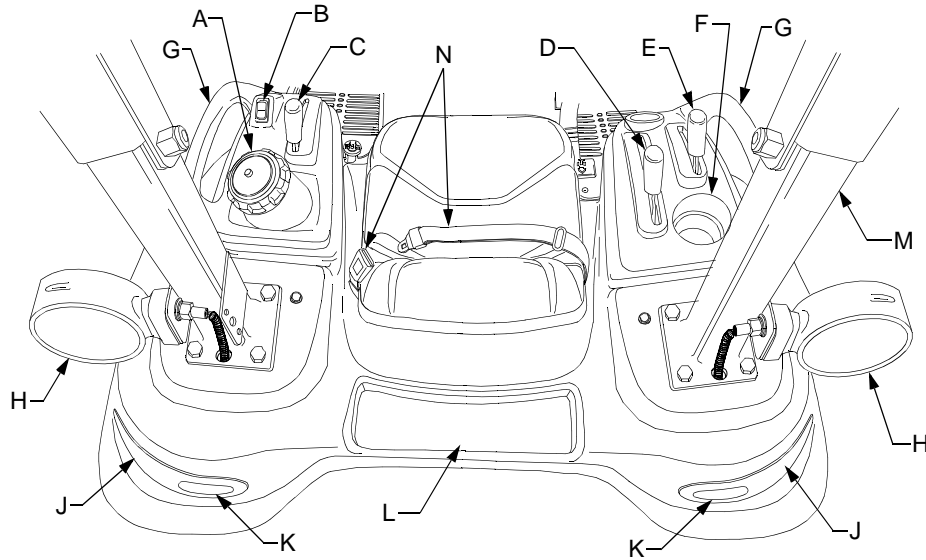

Figure 11

A Fuel Fill Cap	G Hand Holds
B PTO Reverse Override Switch	H Amber Hazard Lights
C PTO Selection Lever	J Tail Lights (Red)
D Hydraulic Lift Lever	K Reverse Lights (White)
E Trans. Hi/Lo Shift Lever	L Storage Tray
F Cup Holder	M Foldable ROPS
	N Seat Belt

### A. Fuel Fill Cap

The fuel fill cap is located on the left fender beside the operator's seat.



**WARNING:** Never fill the fuel tank to the top of the filler neck. Expansion could result in overflow, allowing highly flammable fuel to come in contact with the operator.

### B. PTO Reverse Override Switch

The PTO reverse override switch is located on the left fender. Depress the front of the switch to engage the override which allows the PTO to operate while the tractor is traveling in the reverse direction. **Once activated, this function remains activated until the ignition switch is turned to the OFF position**, regardless of the number of times the PTO is turned off using the PTO switch.



**WARNING:** Use **EXTREME** caution when operating PTO driven attachments while traveling in the reverse direction.

### C. PTO Selection Lever

The PTO selection lever is located on the left fender.

- Push the lever forward to engage the mid PTO.
- Push the lever rearward to engage the rear PTO.
- Move the lever to the center position to simultaneously engage both the rear PTO and mid PTO.

### D. Hydraulic Lift Lever w/Position Control

The hydraulic lift lever is located on the right fender. This lever controls the position of the three point hitch lift arms. There is a direct relationship between the position of the lever and the height position of the installed equipment.

- To lower the lift arms, move the lift lever forward until the desired height setting is attained.
- To raise the lift arms, move the lift lever rearward until the desired height setting is attained.

### E. Transmission Hi/Lo Range Shift Lever

The Hi/Lo range shift lever is located on the right fender. The lever has two speed range settings and a neutral position. The lever must be shifted into either the high or low range prior to depressing the forward/reverse pedal to drive the tractor.

- Push the lever forward to shift into the high range.
- Push the lever rearward to shift into the low range.
- Move the lever to the center position to shift into the neutral position.



**WARNING: Never attempt to shift the range lever when the tractor is in motion.**

### F. Cup Holder

The cup holder is located on the right fender.

### G. Hand Holds

Hand holds are built into both the left and right hand fender covers. The handles can be used to assist in mounting and dismounting the tractor.

### H. Amber Hazard Lights

The hazard lights are located on each side of the ROPS bar. The lights illuminate in a flashing mode when the hazard light switch is turned on. Always use the hazard lights when it is necessary to warn others that the tractor is being operated in the area.

### J. Tail Lights

The tail lights illuminate when the ignition switch is in the ON position and the headlight switch is turned on.

### K. Reverse Lights

The reverse lights illuminate when the tractor is being operated in the reverse direction.

### L. Storage Tray

The storage tray is located behind the seat. Use the tray to carry small loose articles while operating the tractor.

### M. Foldable ROPS (Rollover Protective Structure)

ROPS is installed to prevent or reduce injuries to the operator should the tractor accidentally overturn. The foldable feature allows the ROPS to be lowered when operating in areas with low overhead clearance. The protection provided by the ROPS is minimized if the seat belt is not used and eliminated when in the folded position.

### N. Seat Belt

The seat belt, properly adjusted and used in conjunction with the Rollover Protective Structure (ROPS), can greatly reduce the risk of serious injury or death to the operator if an accidental tractor overturn occurs.



**WARNING: DO NOT use the seat belt if the ROPS is in the folded position, or the structure has been removed from the tractor.**

## SECTION 2: OPERATION

### ROLLOVER PROTECTIVE STRUCTURE (ROPS)

This tractor is equipped with a foldable Rollover Protection Structure (ROPS) and seat belts. When used together they are effective in reducing injuries to the operator in the event of an accidental tractor rollover. The safety provided by the ROPS is minimized if the seat belt is not properly adjusted AND buckled. Refer to **ADJUSTMENTS** for seat belt adjustment.

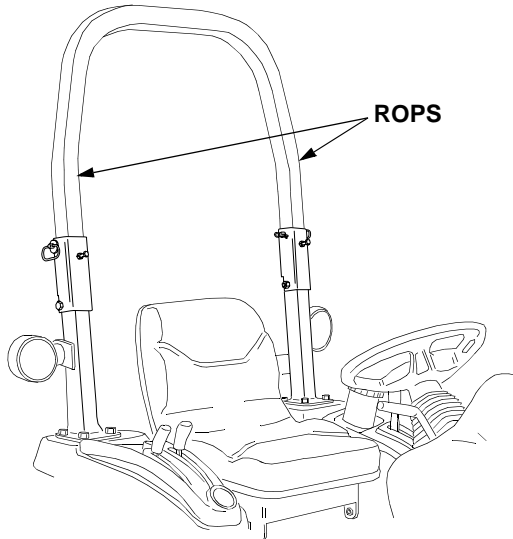

Figure 12



**WARNING:** Always wear the seat belt when operating the tractor equipped with a ROPS. However, if the ROPS is in the folded position or has been removed, the seat belt must not be used.

Use the following guidelines when using a tractor equipped with a ROPS:

- Be aware of overhead clearances in the area of operation. Check for clearance of door (or gate) openings and other overhead objects such as utility lines and tree branches. Overhead objects could catch the ROPS and upset the tractor.
- Do not modify the ROPS by drilling holes for, or welding accessories to the structure.
- Do not use the ROPS to pull objects with the tractor. Use **ONLY** the tractor drawbar for pulling.
- In the event of an accident, have the ROPS carefully inspected and, if necessary, replaced by your *Cub Cadet* dealer. Do not attempt to repair the ROPS.

### FOLDING THE ROPS

The foldable ROPS feature allows the operator to quickly lower the ROPS to operate in areas where there is low overhead clearance. However, the ROPS should be used in the lowered position only when absolutely necessary. Operate with the ROPS in the 'up' position whenever possible.



**WARNING:** A folded ROPS does not provide rollover protection. When the ROPS is in the folded position, the seat belt must **NOT** be used.

Reposition the ROPS as follows:

- Slightly loosen the two hex screws on the front of the ROPS to relieve their pressure on the ROPS. See Figure 13.
- Remove the two internal cotter pins, and, while supporting the ROPS, withdraw the clevis pins. See Figure 13. Carefully lower the ROPS.
- Reinstall the clevis pins and cotter pins for storage.

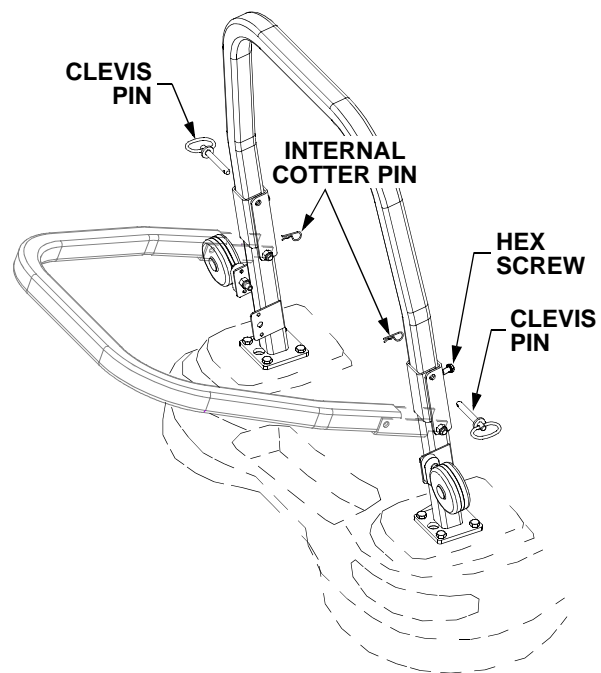

Figure 13

To raise the ROPS:

- Remove internal cotter pins and clevis pins and lift the ROPS into position.
- Insert the clevis pins and secure with the internal cotter pins.
- Tighten the hex screws against the ROPS.

## SAFETY INTERLOCK SYSTEM

This tractor is equipped with a safety interlock system for the protection of the operator. If the interlock system should ever malfunction, do not operate the tractor. Contact your authorized *Cub Cadet Dealer*. The safety interlock system prevents the engine from cranking or starting unless the brake pedal is fully depressed, and the PTO is "OFF".

- The safety interlock system will shut off the engine if the operator leaves the seat before engaging the parking brake.
- The safety interlock system will shut off the engine if the operator leaves the seat with the PTO "ON", regardless of whether the brake lock is engaged.

**NOTE:** *The PTO switch must be moved to the "OFF" position to restart the engine. If the reverse override function had been activated, it will remain activated until the ignition switch is turned to the "OFF" position.*

- The safety interlock system will shut off the PTO if the *reverse control pedal* is depressed, unless the reverse override function is activated.

## FUELING THE TRACTOR

Fill the fuel tank with only clean, fresh, diesel fuel with a minimum cetane number of 40. To ensure the freshness of the fuel, purchase fuel in a quantity that can be used within 30 days.

**NOTE:** *DO NOT USE KEROSENE OR GASOLINE in your diesel engine. Damage to the engine will occur.*

Generally a good grade Number Two Diesel Fuel should be used in your diesel engine. However, in extremely cold temperatures a quality Number One Diesel Fuel, or a blend of Number One and Number Two Diesel fuels should be used. In most areas, diesel fuel is properly blended for seasonal use as ambient temperatures change. Therefore, it is important to monitor fuel purchases so that seasonal grade fuels are not carried over after the average ambient temperature has changed.



**WARNING:** Never fill the fuel tank to the top of the filler neck. Expansion could result in overflow through the vents in the cap, allowing fuel to come in contact with the operator.

- Do not smoke while refueling the tractor.
- Do not fill the fuel tank when the engine is running or while the engine is hot.
- The fuel fill cap is located on the fender to the left of the seat. Unscrew the fuel cap and fill tank from an approved container. Do not fill the fuel tank to capacity. Allow room for expansion.
- Tighten the fuel cap securely, and immediately wipe up any spilled fuel.
- To minimize condensation, keep the fuel tank as full as possible without filling to capacity. It is a good practice to fill the fuel tank at the end of the day to reduce overnight condensation.
- Do not allow the fuel tank to run dry. Running out of fuel requires bleeding air and repriming the fuel system.



**WARNING:** Fuel in the engine injection system is under high pressure. If not a qualified mechanic, do not attempt to service the fuel injection system. Do not use your hand to check for leaks.

## NEW TRACTOR BREAK-IN PROCEDURES

Proper care during the first hours of operation will help to assure optimal performance from your new tractor.

- Never operate a new engine immediately under full load. Allow the engine to warm up.
- Avoid operating the engine for prolonged periods at either high or low speeds with no load.
- Use the transmission's low speed range for heavy loads to avoid lugging of the engine due to overload.
- Closely monitor the engine oil and coolant levels, and keep filled to the recommended levels.
- After the first ten hours of operation, check all of the front and rear wheel bolts. If necessary, retighten to the following torque:  
Front Wheels — 55 ft. lbs.  
Rear Wheels — 80 ft. lbs.
- Perform all break-in maintenance procedures found in the MAINTENANCE section.



## STARTING THE ENGINE



**WARNING:** Always sit in the operator's seat when starting the tractor, Never attempt to start the engine while standing beside the tractor.



**WARNING:** Never use starting fluids, such as ether, as a starting aid. Severe engine damage or fire could result.

- Operator must be sitting in the tractor seat.
- Move the throttle handle to approximately the "MID" throttle position. Refer to Figure 14.
- Make sure the PTO switch is in the "OFF" position. *Note: The PTO light on instrument panel will flash if switch is in ON position.*

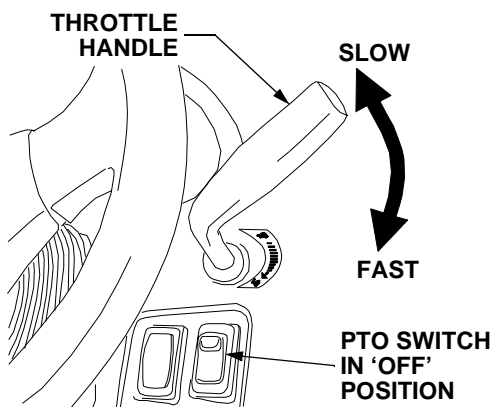

Figure 14

- Either fully depress and hold the brake pedal or engage the parking brake. *Note: The parking brake indicator on instrument panel will flash if pedal is not depressed.*
- Turn the ignition key clockwise to the "RUN-PREHEAT" position, and observe the glow plug indicator light on the instrument panel. Wait until the glow plug indicator light turns off before cranking the engine.  
**NOTE:** Preheating may not be necessary if the engine has been running and is warm.
- Turn the ignition key to the "START" position and release it as soon as the engine starts; however, do not crank the engine continuously for more than 15 seconds at a time. If the engine does not start within this time, turn the key to "OFF" and wait at least one minute to allow the engine's starter motor to cool. Try again after waiting.
- After the engine has started, allow the engine to run for approximately three to five minutes at low throttle before putting the engine under load.

- Observe the instrument panel. If the battery indicator light, oil pressure light, or coolant temperature light comes on, immediately stop the engine. Have the tractor inspected by your *Cub Cadet* dealer.

## COLD WEATHER STARTING

Follow the normal engine starting instructions above. **NOTE:** An optional engine coolant heater is available from your *Cub Cadet* dealer. This heater will aid in starting the tractor when ambient temperatures fall below 10°F (-12°C).

## USING JUMPER CABLES TO START THE ENGINE



**WARNING:** Batteries contain sulfuric acid and produce explosive gasses. Make certain the area is well ventilated, wear gloves and eye protection, and avoid sparks or flames near the battery.

If the battery loses power and is unable to adequately crank the engine to start it, the aid of a booster battery may be necessary. Connect the booster battery as follows:

- Connect the ends of one jumper cable to the positive terminals of both the disabled tractor battery and the booster battery.
- Connect one end of the other cable to the booster battery's negative terminal.
- Connect the other end of that cable to the engine block or frame of the disabled tractor, as far from the battery as possible.
- Start the disabled tractor following the normal starting instructions previously provided; then disconnect the jumper cables in the exact reverse order of connection.
- Have the tractor's electrical system checked and repaired as soon as possible to eliminate the need for jump starting.

## STOPPING THE ENGINE

- Place the PTO switch in the "OFF" position.
- Place the throttle control lever in the "SLOW" position and allow the engine to idle for about one minute.
- Turn the ignition key to the "OFF" position and remove the key from the ignition switch.

**NOTE:** Always remove the key from the ignition switch to prevent accidental starting or battery discharge if the equipment is left unattended.

## DRIVING THE TRACTOR



**WARNING: Avoid sudden starts, excessive speed and sudden stops.**



**WARNING: Do not leave the seat of the tractor without disengaging the PTO and engaging the parking brake. If leaving the tractor unattended, turn the ignition key off and remove key.**

- Adjust the operator's seat to the most comfortable position that allows you to operate all controls and pedals. See seat adjustment in the **ADJUSTMENTS** section.



**WARNING: DO NOT use the seat belt if the ROPS is in the folded position or has been removed from the tractor.**

- Adjust the seat belt to fit snugly but comfortably around your lap, then buckle the seat belt. Refer to **ADJUSTMENTS** section.
- Shift the transmission Hi/Lo range shift lever on the right fender to the desired speed setting. Refer to **USING THE HI/LO RANGE SHIFT LEVER** in paragraphs below.
- Use the tractor and/or the auxiliary hydraulic lift lever(s) to raise all tractor attachments from the ground if transporting the tractor to a work site.
- Depress the brake pedal to release the parking brake, then slowly release the brake pedal.
- Move the throttle handle to the position where the engine operates best for the load to be handled (normally full throttle).
- Slowly depress either the front or rear of the forward/reverse pedal to move the tractor in the desired direction. Refer to **USING THE FORWARD/REVERSE PEDAL**.

## DRIVING ON SLOPES



**WARNING: Do not operate on inclines with a slope in excess of 15 degrees (a rise of approximately 2-1/2 feet every 10 feet). The tractor could overturn and cause serious injury.**

**IMPORTANT: Always shift the transmission into the LOW speed range BEFORE beginning the climb or descent of any slope.**

Operate the tractor up and down slopes, never across slopes. Do not drive so that the tractor may tip over sideways.

Before operating the tractor on a slope, walk the slope to look for possible hazards such as rocks, mounds, stumps, or surface irregularities which could cause the tractor to be upset.

Back the tractor with attachment up the steepest portion of each slope you intend to work. If the tractor cannot negotiate the slope in reverse, the slope is too steep to be worked.

Avoid turns when driving on a slope. If a turn must be made, turn down the slope. Turning up a slope greatly increases the chance of a roll over.

Avoid stopping when driving up a slope. If it is necessary to stop while driving up a slope, start up smoothly and carefully to reduce the possibility of flipping the tractor over backward.

## STOPPING THE TRACTOR

- Fully depress the brake pedal to bring the tractor to a complete stop. Push downward on the parking brake lever and release the pedal to engage the parking brake. Refer to Figure 15.
- Disengage the PTO using the PTO switch.
- Place the throttle control lever in the "SLOW" position and allow the engine to idle for about one minute; then turn the ignition switch to "OFF" and remove the key from the switch.
- Depress the center button of the seat belt buckle to release the seat belt before dismounting.

## USING THE FORWARD/REVERSE PEDAL

The hydrostatic transmission provides constantly variable ground speeds within the speed rating of each transmission range. The tractor speed is controlled by the forward/reverse rocker pedal on the *right* floorboard.

The forward/reverse pedal is self neutralizing. The transmission and pedal return to neutral and the tractor stops when the pedal is released.

- To move forward, slowly depress the front of the forward/reverse pedal until the desired speed is achieved. The speed of the tractor is directly related to the distance the pedal is depressed. Refer to Figure 15.
- To move in reverse, check that the area behind is clear then slowly depress the rear of the forward/reverse pedal.
- When traveling short distances with frequent changes in direction, the forward/reverse rocker pedal may be operated using the heel/toe method. Place your foot on the center section of the pedal and press downward with your toes to move forward. Press downward with your heel to move in reverse.

**NOTE: Slightly more effort is needed to depress the forward/reverse pedal using the heel/toe method.**

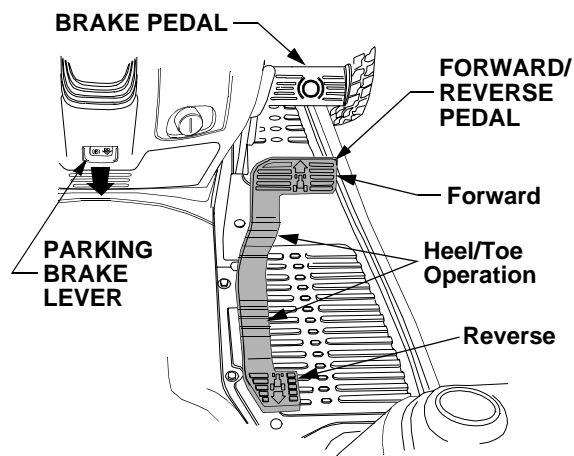

Figure 15



**WARNING:** The forward/reverse pedal will not operate when the parking brake is engaged. Do not attempt to force the pedal when the parking brake is engaged; this could cause premature wear or damage to the drive linkage.

#### USING THE HI/LO RANGE SHIFT LEVER



**WARNING:** The tractor must be stopped before engaging or disengaging the transmission Hi/Lo range shift lever. Shifting while the tractor is in motion will cause damage to the transmission.



**WARNING:** Always maintain a tractor speed that allows for complete control and stability of the machine. Be aware of dangerous areas or conditions.

**Hi range** — Forward speed 0 to 11.0 mph.  
Reverse speed 0 to 5.5 mph.

Shift the lever fully forward in the slot. See Figure 16.

Hi range is normally used for transport and can be used with some tractor attachments.

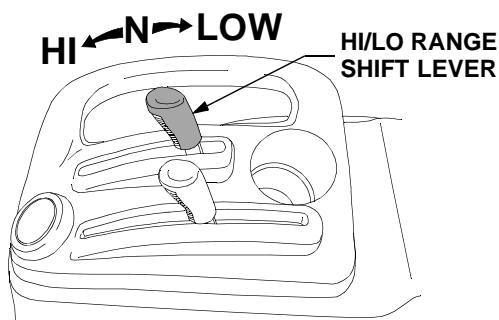

Figure 16

**LOW range** — Forward speed 0 to 6.4 mph.  
Reverse speed 0 to 3.2 mph.

Shift the lever fully rearward in the slot.

Low range is recommended for use with most PTO driven tractor attachments. **Low range must be used when climbing or descending slopes.**

**NEUTRAL** — Disengages the transmission drive. Shift the lever to the center of the slot.

Use **ONLY** for towing or moving the tractor when not under power.

#### USING THE DIFFERENTIAL LOCK PEDAL

Depressing the differential lock pedal engages a mechanism in the transmission that locks the differential. This prevents the rear wheels from rotating independently of each other and provides constant power to both rear wheels when additional traction is needed.

**IMPORTANT:** *Do not engage the differential lock when one of the rear wheels is rotating. Stop the wheel rotation and then engage the differential lock.*



**WARNING:** When operating with the differential lock engaged, the tractor will be difficult to steer. Do not drive the tractor on roadways or at high speeds with the differential lock engaged.

- Fully depress and hold the differential lock pedal to engage the transmission differential lock. Release the pedal to disengage the differential lock. See Figure 17.

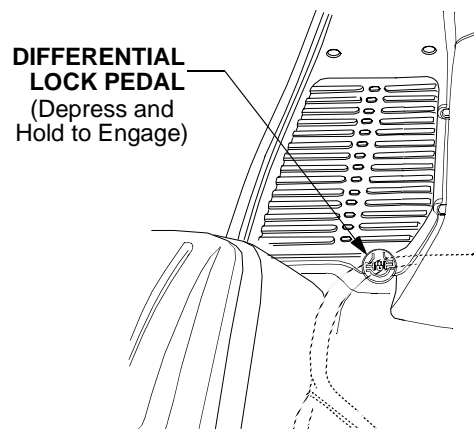

Figure 17

**NOTE:** *Because of the drive load on the internal engagement mechanism, releasing the differential lock pedal may not always disengage the differential lock. It may be necessary to slow the tractor, or reverse the direction of travel, to disengage the differential lock.*

## USING THE HYDRAULIC LIFT LEVER

The hydraulic lift system provides power for raising and positioning three point hitch and belly mounted equipment. The system's position control feature maintains the selected height or depth of the equipment. When the hydraulic lift lever is moved to a higher or lower setting, the system repositions the equipment and maintains that selected position.

- To raise an attachment using the hydraulic lift system, the engine must be running.
- Generally, an attachment can be lowered with the engine running or off.
- There is a direct relationship between the height of the equipment and the position of the lever in its slot. Operate the equipment to determine your preferred height setting and, consequently, the position of the lift lever in its slot.
- Move the lift lever forward in the slot to the position that lowers the equipment to the desired height setting. See Figure 18.

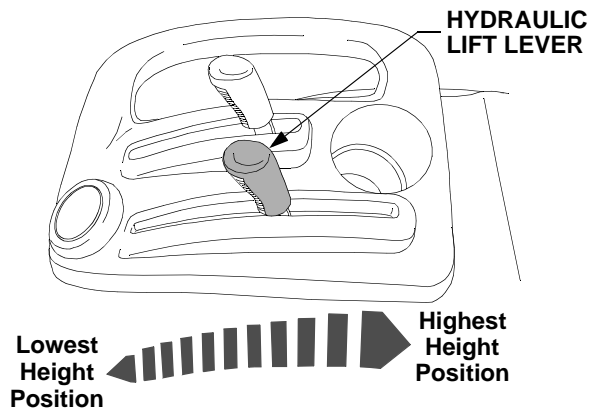

Figure 18

- Move the lift lever rearward in the slot to raise the equipment to a higher height setting, or all the way rearward to raise the equipment to the transport position. See Figure 18.

## USING THE PTO SELECTION LEVER

The position of the PTO selection lever will determine whether the rear PTO, mid PTO, or both PTO's will be engaged when the PTO switch is activated.



**WARNING: NEVER shift the PTO selection lever while the PTO is engaged. Damage to internal components will occur.**

- Shift the PTO selection lever rearward to select the rear PTO. The rear PTO is used to drive

equipment designed to operate at an input speed of 540 RPM. See Figure 19.

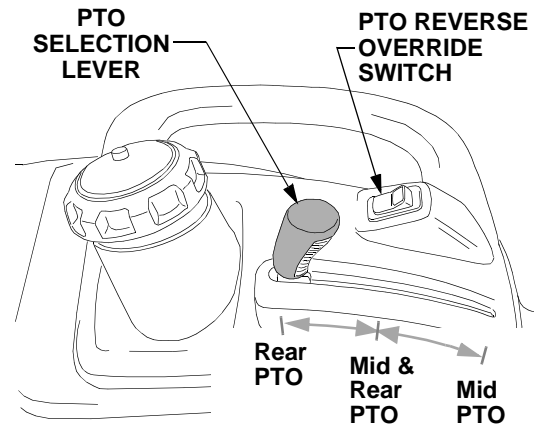

Figure 19

- Shift the PTO lever forward to select the mid PTO. The mid PTO is used to drive equipment designed to operate at an input speed of 2000 RPM. Refer to Figure 19.
- Shift the PTO lever to the middle position to select both the mid PTO and rear PTO. The mid PTO and rear PTO will run simultaneously when the PTO switch is activated. Refer to Figure 19.

**NOTE:** Occasionally you may not be able to shift from one PTO selection to another due to a slight misalignment between the internal shift collar and the gears. In these instances it will be necessary to 'jog' the PTO while shifting the selection lever. Momentarily engage the PTO while applying light pressure on the shift lever to fully engage the internal gears.

## ENGAGING THE PTO



**WARNING: The operator must be in the seat at all times when the PTO is engaged. If the operator should leave the seat without turning off the PTO switch, the tractor's engine will shut off.**

- Move the throttle handle to the mid throttle position. See Figure 20.
- Slide the lock button rearward and then push the *top* of the PTO switch downward to engage the PTO. See Figure 20.
- Observing the tachometer on the instrument panel, use the throttle handle to increase the engine speed to the PTO operating range (3500 rpm) as indicated by the orange line of the tachometer.

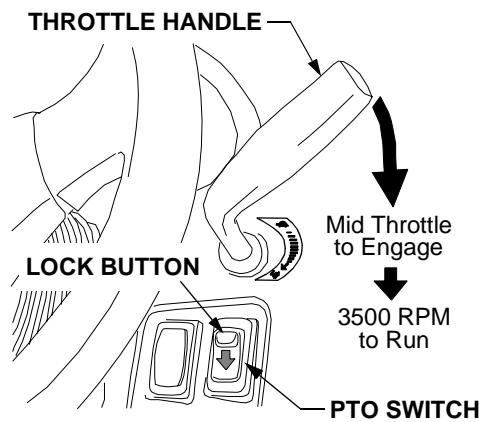

Figure 20

- Push the *bottom* of the switch downward to disengage the PTO.

**IMPORTANT:** *Normally the PTO will not operate when the tractor is driven in the reverse direction. The PTO reverse override switch must be activated to operate the PTO while traveling in reverse.*

#### USING THE PTO REVERSE OVERRIDE SWITCH

The PTO reverse override switch, located on the *left* fender, allows the PTO to operate while the tractor is traveling in the reverse direction. Refer to Figure 19.

- The PTO must first be engaged using the PTO switch on the dash panel.
- Depress the front of the override switch to activate the reverse override system. The light in the override switch will come on.

**IMPORTANT:** *Once activated, the reverse override will remain activated until the ignition switch is turned to the OFF position, regardless of the number of times the PTO is engaged and disengaged using the PTO switch. If the override switch is illuminated, the system is activated.*



**WARNING:** Use **EXTREME CAUTION** when operating PTO driven attachments while traveling in the reverse direction.

#### LIGHTING

##### Headlights and Taillights

Always use the headlights and taillights for after dusk and pre-dawn operation of the tractor. The lights not only illuminate the work area, but also increase the visibility of the tractor for anyone who might enter the area of operation.

The headlights use two halogen bulbs per side. The placement of the bulbs provide a broad light range for safer operation of the tractor in low light conditions.

- To turn on the headlights and taillights, depress the top end of the headlight switch located to the left of the steering wheel.
- To turn off the headlights and taillights, depress the bottom of the light switch.

Use of headlights and taillights is also recommended when operating the tractor on or near roadways to increase visibility to traffic.

#### Hazard Lights

Always use the flashing amber hazard lights along with the SMV (Slow Moving Vehicle) emblem when operating the tractor on, or near, roadways. Also activate the hazard lights when necessary to warn others that the tractor is being operated in the area.

- To turn on the flashing hazard lights, depress the top end of the hazard light switch located to the left of the headlight switch.
- To turn off the hazard lights, depress the bottom of the light switch.

#### USING THE TOP LINK RETAINER HOOK

The top link hook is provided to retain the the top link of the three point hitch when not in use.

To utilize the top link hook, proceed as follows:

- While holding the top link upward, raise the hook rod and slide it fully to the *left* so that it locks in the upright position in the *right* slot of the mounting bracket.
- Lower the top link into the hook of the rod.
- To release the top link, lift the top link out of the retainer hook; then slide the hook rod fully to the *right* and pivot it downward.

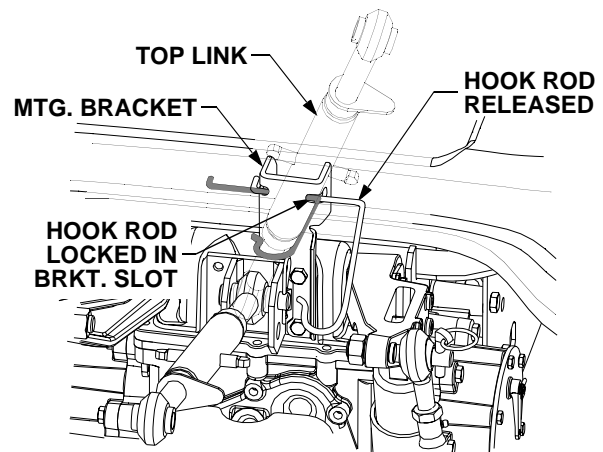

Figure 21

## USING THE THREE POINT HITCH



**WARNING:** Always disengage the PTO, stop the engine, and set the parking brake before dismantling the tractor to connect, disconnect, or adjust three point hitch mounted implements.

Use the rear three point hitch system to attach three point mounted implements, which are normally driven by the rear PTO. Using the position control feature of the tractor's hydraulic lift system, the three point hitch system provides for variable positioning of the implement as well as allowing the implement to be fully raised for transport.

Read the **ADJUSTMENTS** section for instructions on adjusting the RH adjustable lift link, upper hitch link, and hitch chain. See Figure 22.

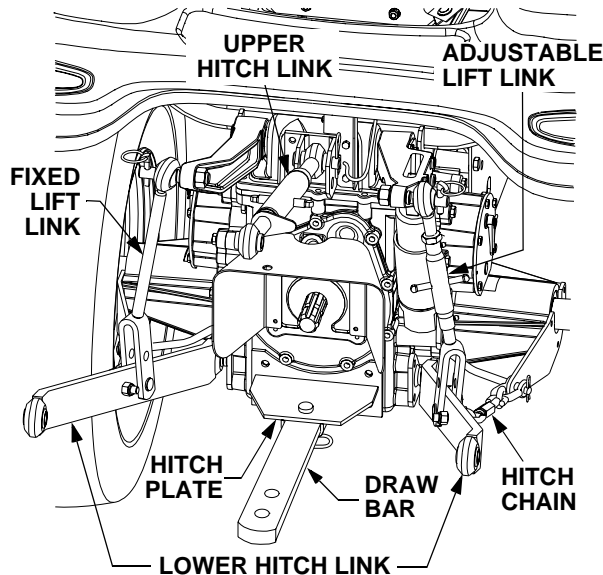

Figure 22

## USING THE HITCH PLATE

Use only the hitch plate and drawbar (Refer to Figure 22), for towing pull-behind equipment (carts, trailers, etc.) or dragging loads.

Raise the lower links of the three point hitch to their highest position to prevent interference with the towed equipment.

**IMPORTANT:** When transporting pull-behind equipment on public roadways, always use a safety chain to supplement the connection between the tractor and towed equipment. The safety chain must have a strength rating equal to or greater than the gross weight of the equipment being towed.

## USING THE AUXILIARY HYDRAULIC VALVE (IF EQUIPPED)

Some tractors may be equipped with an auxiliary hydraulic valve package. This package provides two hydraulic circuits for operating optional equipment that can be installed on the tractor.

The male and female hydraulic couplers, located beneath the right running board, are marked with color coded washers that should match the color coded hydraulic lines of *Cub Cadet* equipment. See Figure 23.

**IMPORTANT:** If color coding is not present, note that the inner hydraulic couplers represent one hydraulic circuit and the outer couplers represent the other. Do not cross connect circuits when connecting hydraulic lines of optional equipment.

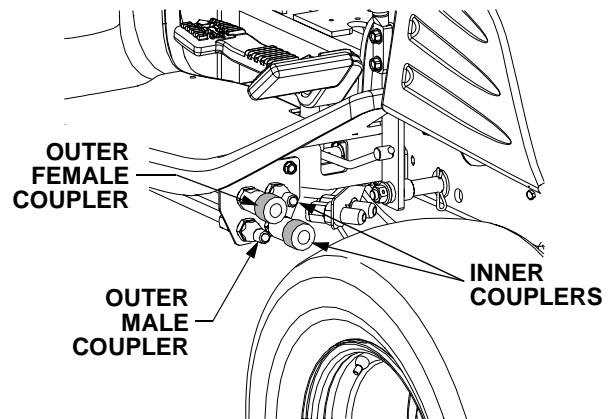

Figure 23

## Using the Auxiliary Hydraulic Control Handle

Use the auxiliary hydraulic control handle located on the right fender as follows:

- Pull the handle rearward to raise the front hitch or front loader boom. See Figure 24.
- Push the handle forward to lower front hitch or front loader boom. Refer to Figure 24.
- Push the handle fully forward until it locks in the detent position to place the front hitch or front loader boom in the float position.
- Push the handle to the right to angle (if equipped) the front hitch to the right or dump the loader bucket. Refer to Figure 24.
- Pull the handle to the left to angle (if equipped) the front hitch to the left or roll back the loader bucket.

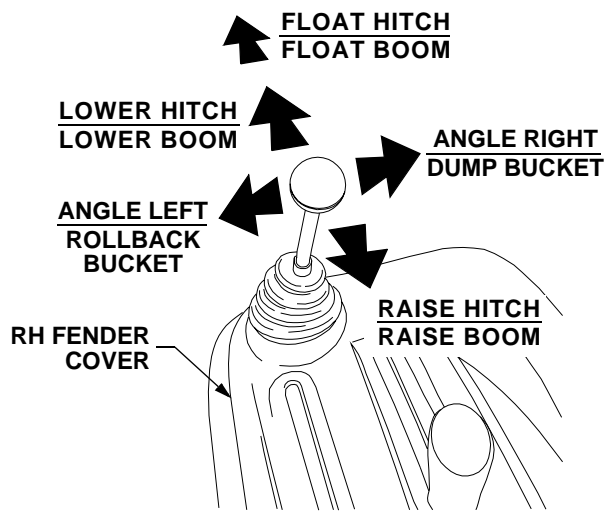

Figure 24

### ON DEMAND FOUR WHEEL DRIVE

The On Demand Four Wheel Drive system automatically delivers power to the front axle whenever the need for additional traction is sensed by the transmission. No action from the operator is required for engagement.

### TRACTOR WEIGHTING

When implements are installed on either the front or rear of the tractor, the normal balance of the tractor is altered.

- As a rear mounted implement is raised to the transport position, the balance point of the tractor shifts rearward, which may result in a loss of steering control and tractor stability.
- When a front mounted implement is raised, the balance point shifts forward and may result in a loss of traction and stability.

To counterbalance these weight shifts, weight should be added to the tractor in the form of either cast iron weights or liquid ballast. However, only enough weight should be added to obtain good traction, control, and stability. Excessive weight will unnecessarily load down the tractor's engine and transmission.

**NOTE:** *When adding weight to the tractor, it may be necessary to increase the inflation pressure in the tires.*

#### Front Weights

To counterbalance three point hitch mounted equipment, a weight bracket/bumper kit and cast iron weights are available from your *Cub Cadet* dealer.

When mounting optional *Cub Cadet* equipment on the rear of the tractor, such as a rotary tiller, rotary cutting deck, or a rear finish mower, the weight bracket and a minimum of four suitcase weights should be used.

For all other rear mounted equipment, follow the guidelines provided in the implement's Operator's Manual to determine how much weight is needed to counterbalance the equipment.

If guidelines are not available, ballast the tractor so that a minimum of approximately 40% of the machine weight is on the front wheels.

### Weighting the Rear of the Tractor

Adding weight to the rear of the tractor is not required for most *Cub Cadet* front mounted equipment currently available for this tractor. However, if installing only the optional front end loader (without the back hoe), weight must be added to the rear of the tractor. The most common methods of adding weight are filling the rear wheels with liquid ballast (usually a calcium chloride and water solution) or mounting a rear weight box.

#### Liquid Ballast

Properly filling the rear tires with liquid ballast increases the weight of each rear wheel to approximately 200 pounds, which should provide adequate counterbalance.

Because special equipment and a familiarity with the practice is required, only a qualified tire technician should perform this procedure. Consult with your *Cub Cadet* dealer about having liquid ballast added to your tires, and for any special maintenance instructions after the procedure is performed.

#### Rear Weight Box

A weight box will provide adequate counterbalance if the following criteria is met:

- The weight box and contents must total a minimum of 200 pounds.
- The weight box must be positioned a minimum of approximately 20 inches rearward of the rear axle, and be carried no more than 12 inches from the ground.

If the weight box is positioned closer to the rear axle or carried higher, additional weight must be added to effectively counterbalance the front loader.

## SECTION 3: ADJUSTMENTS

### ADJUSTING THE SEAT

For the comfort of the operator, a single lever adjustable seat is provided to set the fore to aft position of the seat. Adjust the seat to the most comfortable position that allows you to operate all controls and pedals.



**WARNING: Do not adjust the seat when the tractor is moving, as this could cause the operator to lose momentary control of the tractor and result in an accident.**

- To adjust the seat, pivot the seat adjustment lever to the left and hold while repositioning the seat to the desired position.
- After repositioning the seat, release the lever to lock the seat in position. Slide the seat either slightly forward or rearward to assure it is locked or until engagement of the lock is felt. See Figure 25.

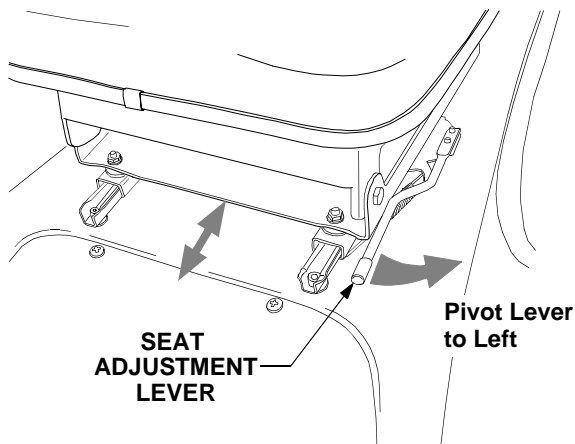

Figure 25

### ADJUSTING THE SEAT BELT



**WARNING: Always wear the seat belt when operating the tractor equipped with a ROPS. However, if the ROPS has been removed, the seat belt should not be used.**

**NOTE:** If the belt is too long or too short to be properly adjusted using the upper belt webbing, the adjustment clip should be repositioned. To do so, firmly grasp the adjustment clip and pull the lower webbing through the clip. Move the clip toward the anchor point at the seat to shorten the belt, or toward the buckle link to lengthen the belt.

Adjust the final length of the seat belt using the adjuster clip, buckle link, and upper belt webbing on the *right* half of the belt.

- To lengthen the belt, hold the ends of the adjuster clip and tip upward the side of the clip toward the buckle link. See Figure 26.
- While holding the clip, pull the upper webbing of the belt through the clip toward the buckle link. See Figure 26.
- Hold the belt and pull the buckle link to the *left* to remove the slack in the upper webbing of the belt between the adjuster clip and the link.

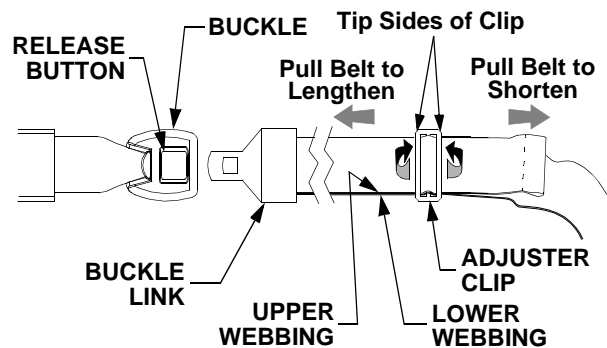

Figure 26

- To shorten the belt, tip the other side of the clip upward, pull the free end of the belt webbing to the *right*, and pull the buckle link to the *left* to remove the slack.

### THREE POINT HITCH ADJUSTMENTS

- Adjust the RH adjustable lift link to *level* the lower hitch links. Loosen the jam nut and turn the adjustment tube as shown in Figure 27 to shorten or lengthen the lift link. Tighten the jam nut against the adjustment tube after adjusting.

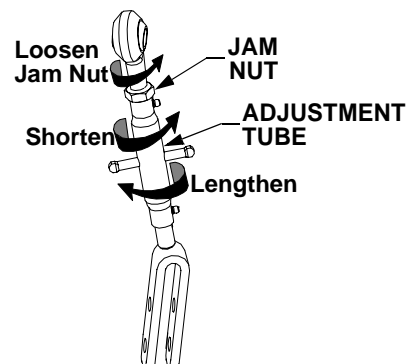

Figure 27



- The length of the upper hitch link is normally determined by the design of each implement. To adjust the upper hitch link, loosen the locking lever and turn the adjustment tube as shown in Figure 28. After the appropriate length is attained, tighten the locking lever. If correctly adjusted, the upper hitch link will be parallel or nearly parallel to the lower hitch links.

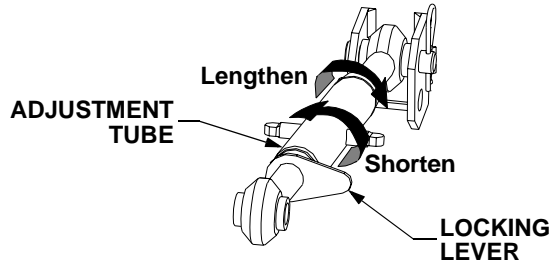

Figure 28

- The length of the hitch chains, attached to each lower hitch link, limit the side-to-side movement of the lower links. Loosen the jam nut and turn the chain's hex shaft as shown in Figure 29 to adjust the length of the hitch chain. Tighten the jam nut after adjusting.

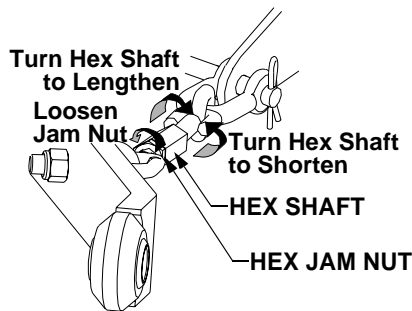

Figure 29

### ADJUSTING FRONT WHEEL TOE-IN

The front wheel toe-in is set at the factory and should maintain the proper setting. However, the toe-in should be checked periodically and readjusted if necessary.

#### CHECK THE TOE-IN AS FOLLOWS:

- Place the tractor on a level surface with the wheels in the straight ahead position.
- Place an easily visible mark on the center lines of both front tires at the horizontal center line of the wheel.
- Measure and record the distance 'A' between the two marks. See Figure 30.
- Roll the tractor forward or rearward until the marks are at the horizontal center line at the rear of the wheels. Measure and record the distance 'B' between the marks. See Figure 30.

- Distance 'A' should be 0"-0.20" less than distance 'B' if the toe-in is correct. If it is not, readjust the toe-in.

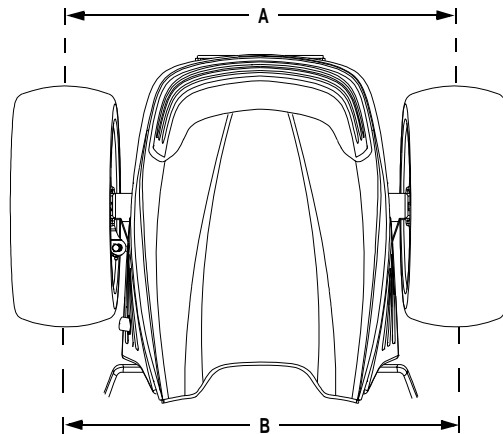

Figure 30

#### READJUST THE TOE-IN AS FOLLOWS:

**NOTE:** The right ball joint and jam nut are left hand threaded.

- Loosen the jam nuts at both the LH and RH ball joints. See Figure 31.
- Using a pair of pliers (or similar tool) to grasp the tie rod, turn the rod as follows:  
Forward to shorten the tie rod and decrease the toe-in. See Figure 31.  
Rearward to lengthen the tie rod and increase the toe-in. See Figure 31.

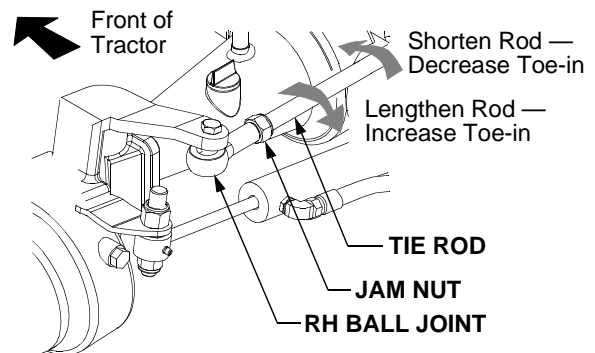

Figure 31

- Readjust the tie rod as necessary to obtain the correct toe-in, then tighten the jam nuts against the ball joints.

## ADJUSTING THE BRAKES

The tractor brakes are adjusted at the factory and should experience minimal wear if the tractor is operated normally. However, all brake pads are subject to wear and at some point the brake linkage may have to be adjusted.

Check the brake linkage as follows:

- Place the tractor on a level surface.
- Stop the tractor engine and engage the parking brake.
- From the right/rear side of the tractor, check the gap between the flange of the brake rod and the ferrule connected to the transmission brake arm. The gap should be a minimum of .160". See Figure 32.
- Check the gap of the brake rod on the left side of the tractor in the same manner.
- If either gap is less than .160", the brake rod should be adjusted.

Adjust the brake linkage as follows:

- Disengage the parking brake.
- Remove the internal cotter pin and disengage the adjustment ferrule at the front of the brake rod from the brake link. See Figure 32.

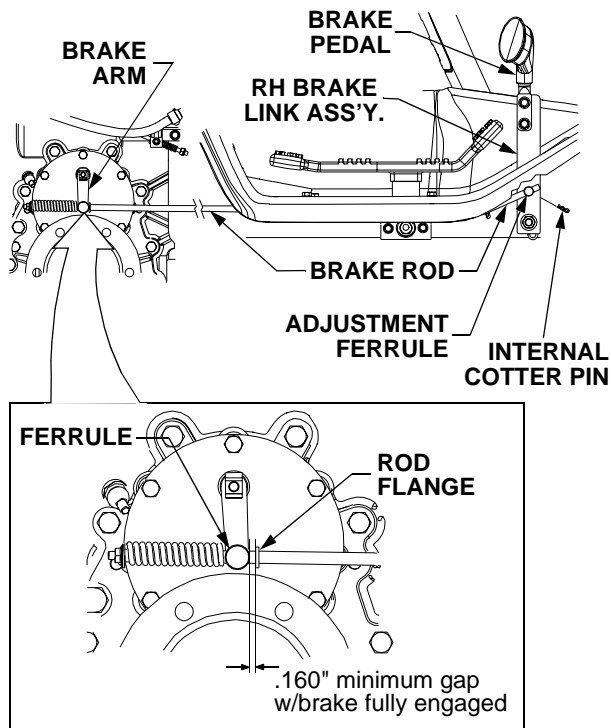

Figure 32

- Turn the adjustment ferrule onto the rod as needed to shorten the rod and acquire the .160" minimum gap.
- Reinstall the ferrule and internal cotter pin in the brake link.
- Engage the parking brake and recheck the brake rod gaps. Repeat the above procedures as necessary to obtain the specified minimum gap.

## ADJUSTING HYDRAULIC LIFT FEEDBACK ROD

Correct adjustment of the feedback rod (Refer to Figure 33) is instrumental in proper operation of the position control hydraulic lift system.

The feedback rod is adjusted at the factory and should not require further adjustment. Because of the precise nature of the feedback rod adjustment, it is recommended that any adjustment be performed by a qualified mechanic at your Cub Cadet dealer.

If a high pitched squeal continues to emit from the lift valve after repositioning the lift, or the position control feature is not functioning properly, have the position control linkage inspected by your local Cub Cadet dealer. Refer to Figure 33.

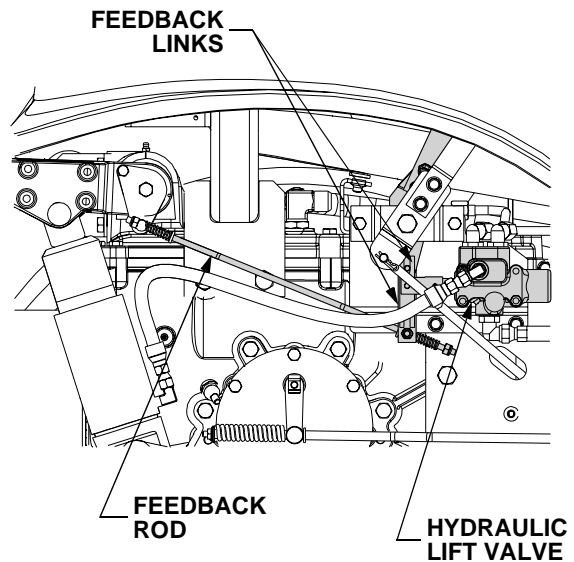

Figure 33

## SECTION 4: MAINTENANCE

The service life and reliability of any machine depends upon the care it is given. Proper lubrication and maintenance is a vital part of that care. Using the *Lubrication and Maintenance Chart* as a guide, monitor the hourmeter on the instrument panel to ensure the required maintenance procedures are performed. The maintenance schedule reflects the minimal requirements to maintain the equipment. More frequent inspections and maintenance is preferable.

Make certain that all lubrication fittings are installed and functioning. Wipe away all old grease and dirt from the lube fittings to prevent foreign materials from entering as the new grease is applied. Use a

pressure lubricating gun to force in new grease. Apply pressure until clean grease emerges from the lubrication point.

Miscellaneous working parts not provided with lubrication fittings should be oiled regularly with a good grade of lubricating oil.

Lubricate the tractor thoroughly before taking it to a remote location for a prolonged period of time.

Lubricant is cheap. Use plenty of it. Worn parts can be expensive to replace.

Store your supply of lubricating grease and oil in clean, covered containers to protect them from dust and dirt. Keep the lubricating gun nozzle clean.

## LUBRICATION TABLE

Application	Type of Lubricant	General Information				
		Capacity	API Classification	Anticipated Ambient Temp.	SAE Viscosity	Description
Engine	Engine Oil	Approx. 3.5 Qts. w/Filter	CF or CF-4	Below 50°F	5W-30	Use High Quality Diesel Engine Oil
				0°F and Above	10W-30 —— 10W-40 10W-50	Cub Cadet 737-3066 (1Qt.)  Use High Quality Diesel Engine Oil
				Above 32°F	30W	Cub Cadet 737-3032 (1Qt.)
Transmission and Hydraulic System	Hydraulic Transmission Fluid	Approx. 26 Qts. (6.5 Gal.)		Use Cub Cadet Hydraulic Transmission Fluid 737-3025 (1 Qt.) 737-3062 (1 Gal.) 737-3063 (10 Qt. ) 737-3035 (5 Gal. )		
Front Wheel Drive Axle	Gear Lube	Approx. 81 Oz. (2.5 Qts.)		Use Cub Cadet Gear Lube 737-3065 (1 Qt.)		
Lube Fittings	Grease	As Needed		Use Cub Cadet 251H EP Grease 737-3034 (14.5 Oz. Cartridge)		
Radiator and Overflow Reservoir	Antifreeze	Approx. 5.3 Qts.		Use High Quality Permanent Type Antifreeze (Ethylene Glycol with corrosion and rust inhibitor chemicals) Coolant Mixture Ratio Distilled Water 50% : Antifreeze 50%		

# LUBRICATION AND MAINTENANCE CHART (ILLUSTRATION)

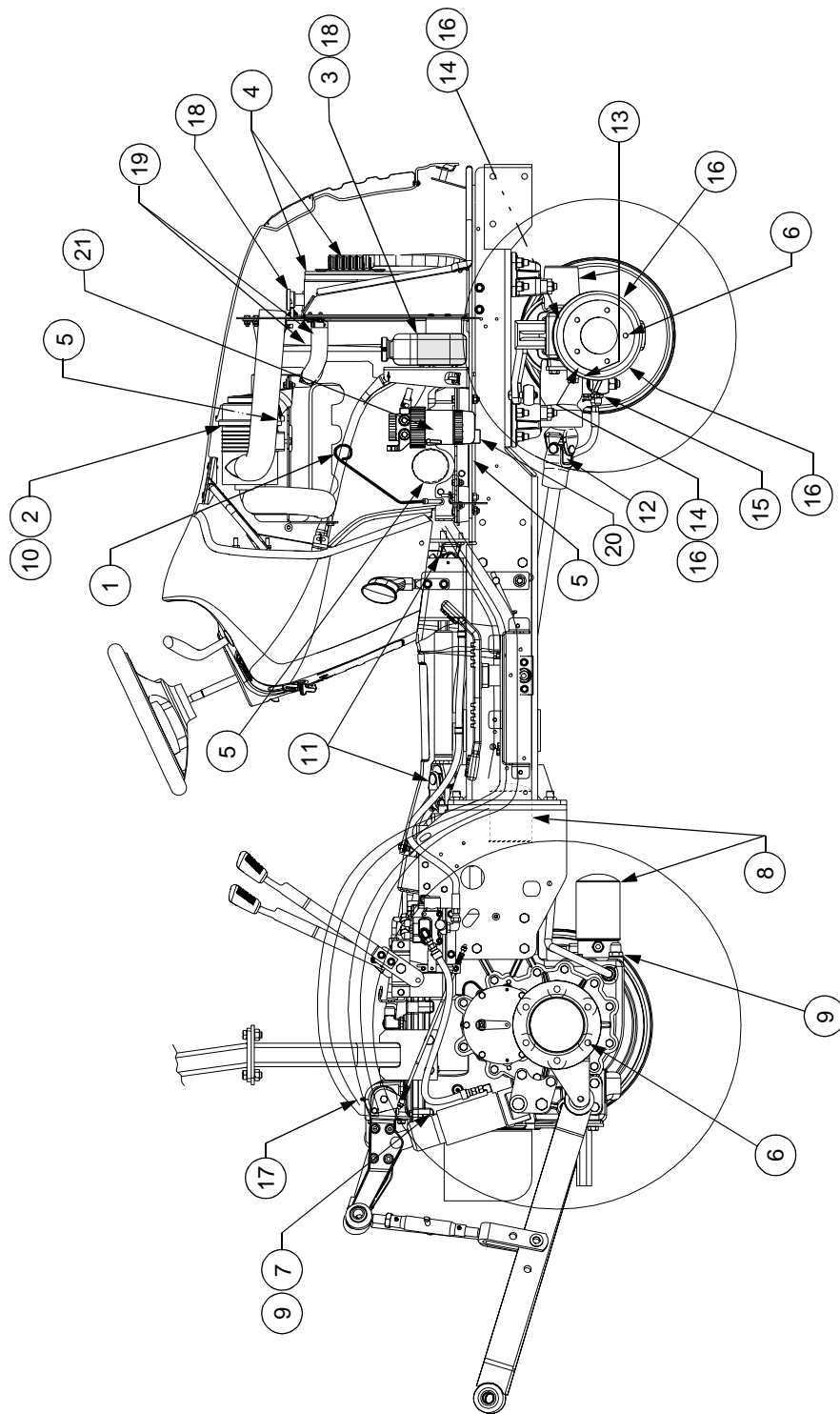

## LUBRICATION AND MAINTENANCE CHART

Ref. No.	Operation to be Performed	Service Intervals									
		Before each use	Every 10 Hours	Every 25 Hours	Every 50 Hours	Every 100 Hours	Every 150 Hours	Every 200 Hours	Every 300 Hours	Every 600 Hours	Before Storage
1	Check Engine Oil Level	•									
2	Check Air Cleaner	•									
3	Check Engine Coolant Level	•									
4	Check and Clean Radiator Screen and Oil Cooler Fins	•									•
5	Change Engine Oil and Replace Oil Filter				first 50 hrs.		•				
6	Retorque Front and Rear Wheel Bolts		first 10 hrs.			•					
7	Check Transmission Oil Level				•						
8	Replace Hydraulic and Hydrostatic Oil Filters			first 25 hrs.				•			
9	Replace Hydraulic and Hydrostatic Oil							•			
10	Replace Air Cleaner Element								†		
11	Grease Drive Shaft (both ends)				•						•
12	Grease FWD Drive Shaft (both ends)				•						•
13	Grease Front Axle Pivot (front and rear lube fittings)		•								•
14	Check Oil Level of Front Axle AND Final Reduction Gear Cases (both sides)				•						
15	Grease Power Steering Cylinder (both ends)				•						•
16	Change Oil in Front Axle AND Final Reduction Gear Cases (both sides)								•		
17	Grease Three Point Lift Shaft				•						•
18	Change Engine Coolant										Yearly
19	Check Radiator Hoses and Fan Belt					•					•
20	Drain Fuel Filter Cup					•					•
21	Replace Fuel Filter Element									•	

† More often when operating under dusty conditions

## ACCESSING THE ENGINE COMPARTMENT



**WARNING:** If the tractor has been recently operated, engine surfaces (including the radiator) will be HOT. Allow the engine to cool before opening the hood, or use extreme caution to avoid burns when the hood is open.

To raise the hood, locate the latch release lever in the hood notch at the front of the tractor. Lift and hold the latch release lever while lifting the hood at the hood notch. See Figure 34.

- Fully raise the hood so that the hood prop cylinders hold the hood in the raised position.

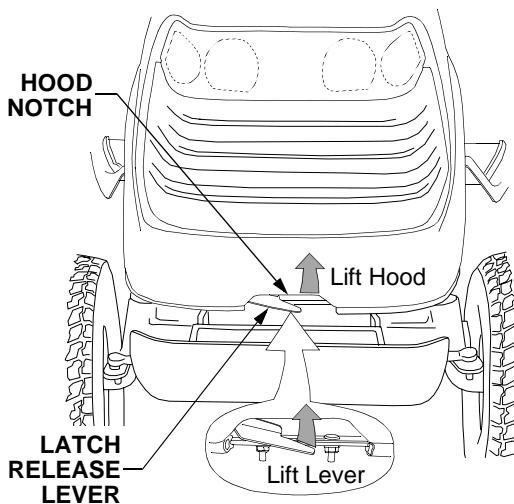

Figure 34

To remove the two side panels:

- Flip the tabs of the two quick release fasteners up and turn to align with the slots in the side panel. See Figure 35.
- Slip the top of the side panel over and off the quick fastener tabs.
- Lift the side panel straight upward and off of the retainer pins.

To reinstall the side panels:

- Align the two holes in the bottom of the side panel with the retainer pins and slide the panel onto the pins. See Figure 35
- Align the tabs of the quick release fasteners with the slots of the side panel and slip the panel over the tabs.

- Pull the quick fastener tabs slightly outward and rotate 1/4 turn (perpendicular to slot) to lock the side panels in place. Flip the fastener tabs down.

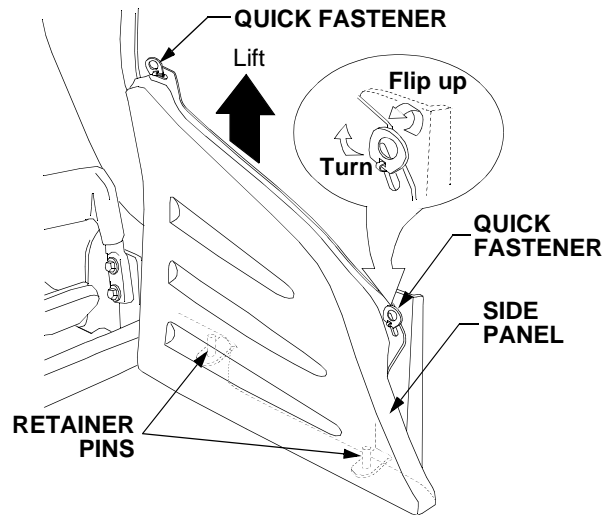

Figure 35

Close the hood by pushing downward until captured by the hood latch.

## GENERAL BATTERY INFORMATION



**WARNING:**

- Battery posts, terminals and related accessories contain lead and lead compounds. Wash hands after handling.
- Battery acid must be handled with great care, as contact with it can burn and blister the skin. It is advisable to wear protective clothing (goggles, rubber gloves and apron) when working with acid.
- Should battery acid accidentally splatter into the eyes or onto the skin, rinse the affected area immediately with clean cold water. If there is any further discomfort, seek prompt medical attention.
- If acid spills on clothing, first dilute it with clean water, then neutralize with a solution of ammonia/water or baking soda/water.

- Because battery acid is corrosive, do not pour it into any sink or drain. Before discarding an empty electrolyte container, rinse it thoroughly with a neutralizing solution.
- NEVER connect (or disconnect) battery charger clips to the battery while the charger is turned on, as it can cause sparks.
- Keep all sources of ignition (cigarettes, matches, lighters) away from the battery. The hydrogen gas generated during charging can be combustible.
- As a further precaution, only charge the battery in a well ventilated area.
- Always shield eyes and protect skin and clothing when working near batteries.



**WARNING: Batteries contain sulfuric acid and may emit explosive gases. Use extreme caution when handling batteries. Keep batteries out of the reach of children.**

#### BATTERY REMOVAL



**WARNING: Battery posts, terminals and related accessories contain lead and lead compounds. Wash hands after handling.**

The battery is located at the front of the tractor beneath the hood, just forward of the radiator.

To remove the battery:

- Open the tractor hood as described in the previous sub-section.
- Remove the two wing nuts and the battery holddown strap from the battery holddown rods. See Figure 36.
- Spread the locking clips on the sides of the terminal covers and lift the tops of the covers to expose the battery connections. See Figure 36
- Loosen the cable clamp of the negative battery lead, then lift the negative cable and its terminal cover off the negative battery post. Move the cable away from the negative battery post.
- Repeat the above procedure to remove the cable and cover from the positive battery post.
- Carefully lift the battery out of the tractor.

Install the battery by repeating the above steps in the reverse order.



**WARNING: Always connect the positive lead to the battery before connecting the negative lead.**

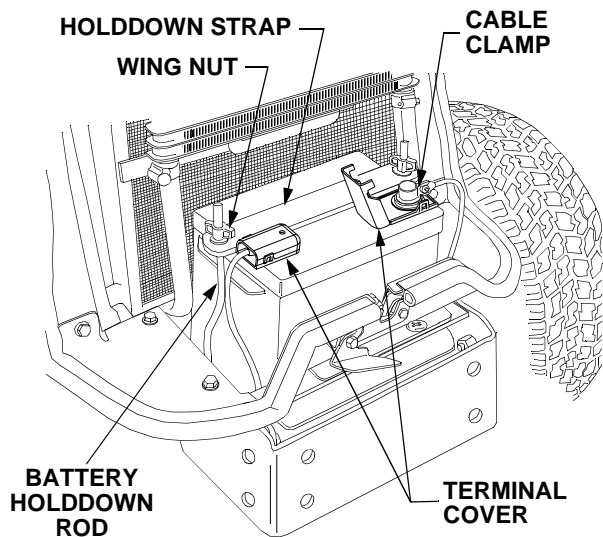

Figure 36

#### BATTERY MAINTENANCE

The battery is filled with battery acid and then sealed at the factory. However, even a “maintenance free” battery requires some maintenance to ensure its proper life cycle.

- Spray the terminals and exposed wire with a battery terminal sealer, or coat the terminals with a thin coat of grease or petroleum jelly, to protect against corrosion.
- The battery should be kept clean. Any deposits of acid should be neutralized with baking soda and water. Be careful not to get this solution in the cells.
- Avoid tipping. Even a sealed battery will leak electrolyte when tipped.

#### BATTERY STORAGE

- When storing the tractor for extended periods, disconnect the battery cables. Removing the battery from the unit is recommended.
- All batteries discharge during storage. Keep the exterior of the battery clean, especially the top. A dirty battery will discharge more rapidly.
- The battery must be stored with a full charge. As the battery discharges, the electrolyte is weakened and will freeze at a higher temperature.
- Recharge the battery before returning to service; or every two months, whichever comes first.

## HEAD LIGHT BULB REPLACEMENT

The tractor is equipped with four headlight bulbs. If one of the bulbs should burn out, replace the bulb as follows:

- Fully raise the hood so that the hood prop cylinders hold the hood in the raised position.
- Pull both locking tabs of the wire harness plug away from the bulb/socket assembly and unplug the wire harness from the bulb assembly. See Figure 37.

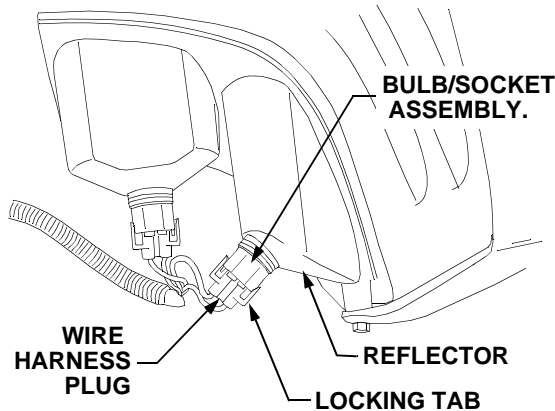

Figure 37

- Turn the bulb/socket assembly approximately a quarter turn counterclockwise to align its tabs with the notches of the reflector, then remove from the reflector.
- Replace with a new bulb/socket assembly (Cub Cadet No. 725-3161A).
- Align the tabs of the new bulb/socket assembly with the notches of the reflector and insert the bulb.
- Turn the bulb/socket assembly clockwise to lock in place. Plug the wire harness into the socket, making sure the plug locking tabs lock onto the socket assembly.

## TAIL LIGHT BULB REPLACEMENT

Each tail light assembly has two light bulbs — a reverse indicator bulb (Cub Cadet no. 725-3263) and a tail light (Cub Cadet no. 725-3262). Access the back side of the tail lights from under the rear fender.

**NOTE:** Use caution when removing the tail light sockets from the reflector housings. The bulbs can be pulled from the sockets and dropped into the reflector housing, requiring removal of the reflector housing to retrieve the bulb.

Replace a tail light bulb as follows:

- Turn the light socket counterclockwise to align the socket tabs with the notches in the tail light reflector.
- Once aligned, carefully pull the light socket out of the tail light reflector.
- Pull the light bulb from the socket and replace with a like part.
- Align the tabs of the socket with the notches in the reflector and carefully insert the socket. Turn the socket fully clockwise to lock in place.

## HAZARD BULB REPLACEMENT

Flashing hazard lights are installed on each side of the ROPS. Replace the bulbs as follows:

- Grasp the outer half of the light housing and both the front and rear lenses. Accessing the screws from the notches at the top and bottom of the outer housing, remove the two screws fastening the outer and inner housings together. See Figure 38.

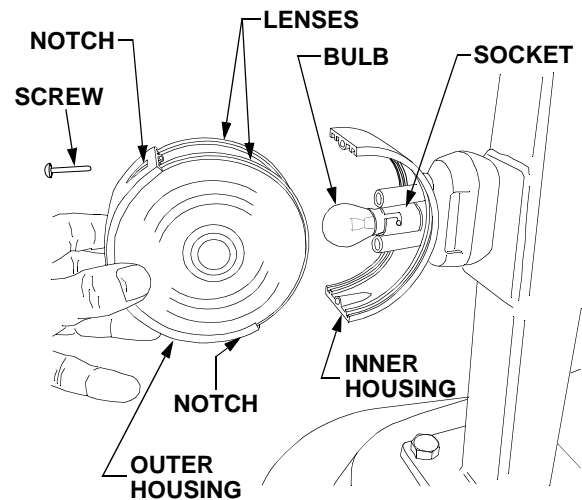

Figure 38

- Remove the outer housing and lenses.
- Push in on the bulb and turn counterclockwise to remove the bulb from the light socket.
- Align the new bulb with the socket slot, push the bulb into the socket, and turn clockwise to lock it in the socket.
- While making certain the lenses engage the front and rear grooves of the inner housing, install the lenses and outer housing. Secure with the two screws.



## INSTRUMENT PANEL BULB REPLACEMENT

Referring to the instrument panel information provided in the **CONTROL AND FEATURES** section of this manual, regularly check to ensure that the instrument panel light bulbs are functioning.

To change a burned out instrument panel bulb:

- Raise the tractor hood to view the back side of the instrument panel.
- Determine the position of the burned out bulb and pull the seal plug from the back of the instrument panel. See Figure 39.

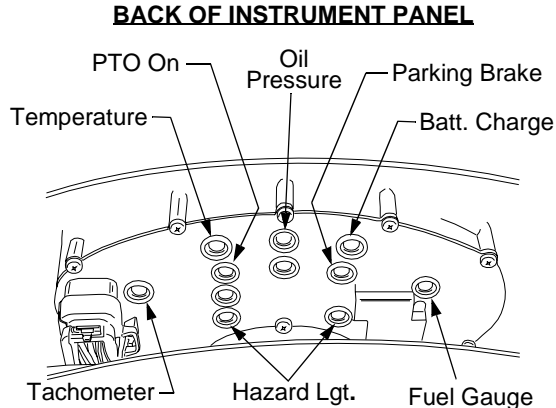

Figure 39

- Using a small flat bladed screw driver in the slot of the bulb socket, turn the socket approximately a quarter turn counterclockwise to unlock from the instrument panel. Carefully withdraw from the panel. *Note the position of the bulb socket locking tabs.*
- Insert the new bulb/socket assembly into the instrument panel in the same manner, making certain the locking tabs of the socket engage the slots of the instrument panel.
- Turn the socket approximately a quarter turn clockwise to lock in place and reinsert the seal plug into the panel opening.

## SERVICING ELECTRICAL SYSTEM

Fuses are installed to protect the tractor's electrical system from damage caused by excessive amperage. Always use the same capacity fuse for replacement. If the electrical system does not function, check for blown fuses. See Figure 40

If you have a recurring problem with blown fuses, have the tractor's electrical system checked by your Cub Cadet dealer.

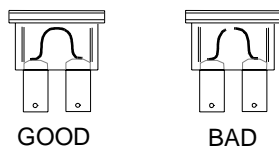

Figure 40

## Accessing the Fuse Center

The fuse center is located on the inside *right* of the dash panel. To access the fuse center, remove the dash panel insert by removing the two screws. See Figure 41.

Reposition the dash panel insert in the dash and secure with the two screws to cover the fuse center.

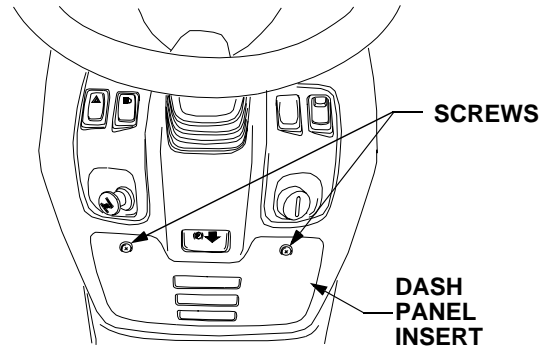

Figure 41

## Instrument Panel Fuses

The instrument panel's circuitry is protected by the two fuses in the fuse center. If the instrument panel does not function properly, check the fuses.

- Pull the two fuses from the fuse center and check their condition. Replace a blown fuse with the same capacity fuse (3 Amp). Refer to Figure 42.

## Relays

The PTO relay and dash power relay, located in the fuse center, maintain power to each of those circuits. If one of the circuits is not functioning properly, have your dealer electrically check the relay. See Figure 42.

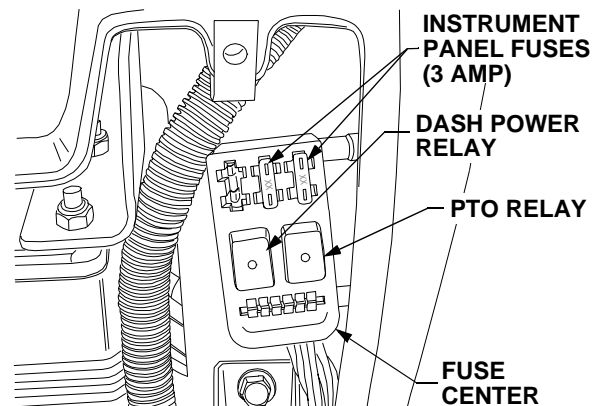

Figure 42

## Main Fuse

The main fuse in the tractor wire harness protects the tractor's entire electrical system. A blown main fuse will prevent battery current from passing through the harness.

To replace the main fuse:

- Raise the tractor hood and remove the right side panel.
- Locate the main fuse under the dash panel, along the tractor's *right* frame rail. See Figure 43.

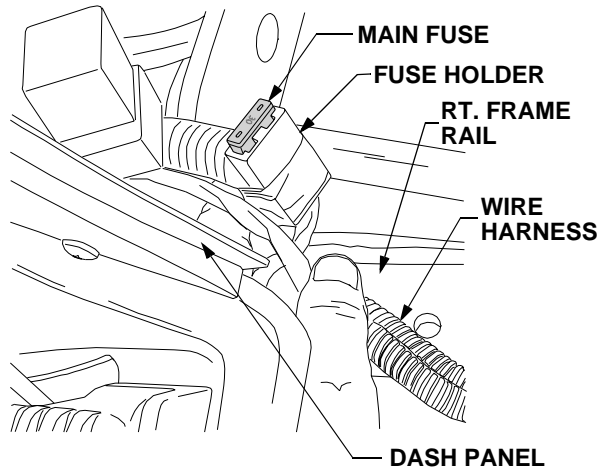

Figure 43

- Pull the fuse from the fuse holder and replace with the same capacity fuse (30 Amp). **NEVER use a higher amperage fuse.**
- Install the side panel and lower the tractor hood.

## Hazard Light Flasher Relay

The flasher relay controls the on/off flashing of the hazard lights. If the hazard lights do not function properly, the flasher relay is probably faulty.

Replace the relay as follows:

- Remove the dash panel insert by removing the two screws. Refer to Figure 41.
- Pull the wire harness from the dash opening. Cut and remove the electrical tape holding the flasher relay to the harness. See Figure 44
- After first noting the position of the two harness leads, disconnect the leads and replace the faulty relay with a new relay.
- Secure the relay to the wire harness with electrical tape.
- Position the wire harness in the dash panel and reinstall the dash panel insert.

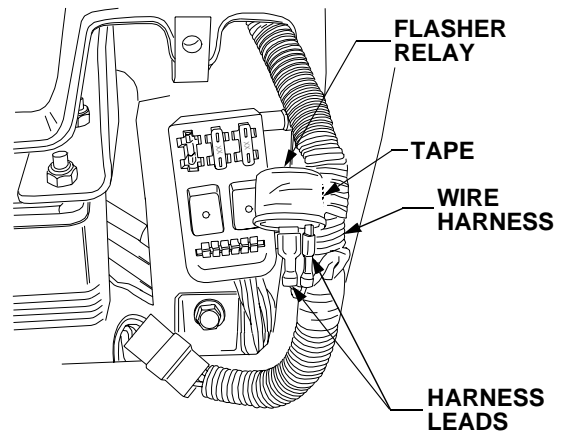

Figure 44

## CHECKING TRANSMISSION/HYDRAULIC SYSTEM OIL LEVEL

Check the hydro transmission/hydraulic system oil level after every 50 hours of operation. Check the oil level only while the engine is stopped and the tractor is standing on a level surface.

The oil fill plug/dipstick is located at the rear of the tractor, above the rear PTO shield. See Figure 45.

- Clean the area around the oil fill plug/dipstick to prevent debris from entering the transmission housing. See Figure 45.
- Turn the oil fill plug/dipstick counterclockwise to unscrew from the transmission housing.
- Withdraw the dipstick and wipe it clean, then reinsert and screw in all the way. Unscrew and withdraw again to read the oil level. Always keep the oil level between the add and full marks on the dipstick (See Figure 45).

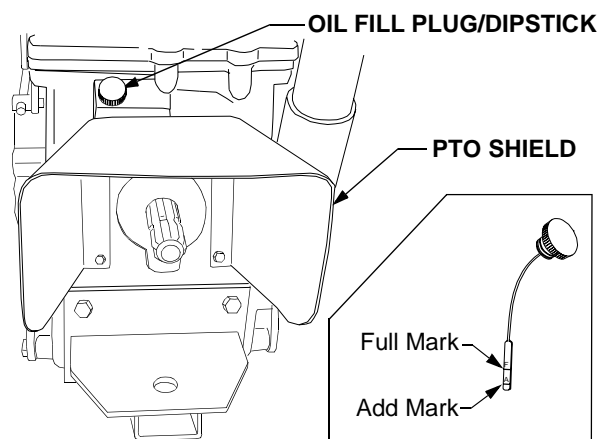

Figure 45

- If the oil level is low, add Cub Cadet hydraulic oil. Loosely position a funnel in the fill hole so that there is enough clearance around the funnel to allow the transmission to vent while the oil is poured into the transmission. Fill **ONLY** to the full mark, **never** overfill the transmission.

**NOTE:** Always use Cub Cadet hydraulic oil to ensure correct formulation. Substitute oils could affect performance and may cause damage to the transmission.

- Reinsert the oil fill plug/dipstick into the transmission housing and turn clockwise until tight.

### CHANGING TRANSMISSION/HYDRAULIC SYSTEM OIL

Change the hydrostatic transmission/hydraulic system oil and filters after every 200 hours of operation. The dry capacity of the transmission/hydraulic system is approximately 26 quarts.

Change the transmission/hydraulic system oil as follows:

- Operate the tractor for a short period to warm the oil to the normal operating temperature. Place the tractor on a level surface, engage the parking brake, and stop the tractor engine.
- Remove any belly mounted attachments.
- Clean the area around the transmission drain plug and the oil fill plug/dipstick to prevent debris from entering the transmission. Refer to Figure 45 and Figure 46.

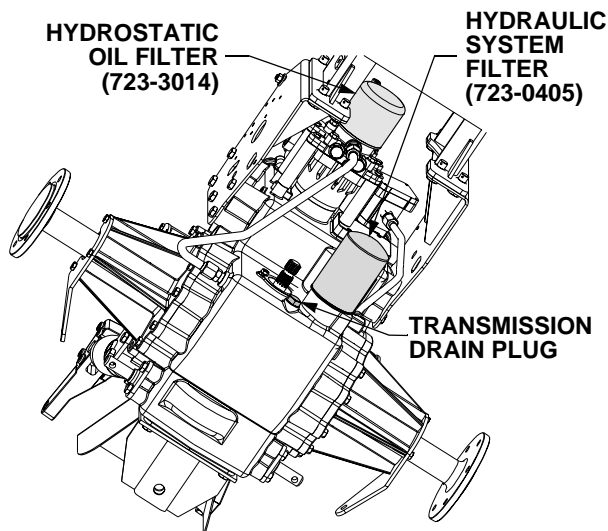

**Viewed from beneath the Tractor**

**Figure 46**

- Place a suitable container(s) beneath the front of the transmission housing.
- Remove the oil fill plug/dipstick to help vent the transmission, then remove the drain plug and allow the transmission oil to drain into the container(s). Reinstall the drain plug after draining the oil. See Figure 46.



Dispose of used oil in an environmentally safe manner. If necessary, contact your area EPA office for proper disposal procedures and recycling center locations.

- Clean around the base of the hydrostatic transmission oil filter and remove the filter by turning it counterclockwise. See Figure 46.
- Apply a light coating of clean transmission oil to the gasket of the new filter. Install the filter by turning it clockwise, by hand, until the gasket contacts the filter base on the transmission housing; then tighten the filter an additional 1/2 to 3/4 turn.
- Clean around the base of the hydraulic system oil filter and remove the filter by turning it counterclockwise. Refer to Figure 46.
- Apply a light coating of clean transmission oil to the gasket of the new filter. Install the filter by turning it clockwise, by hand, until the gasket contacts the filter base on the transmission housing; then tighten the filter an additional 1/2 to 3/4 turn.
- Loosely position a funnel in the oil fill hole so that there is enough clearance around the funnel to allow the transmission to vent while the oil is poured into the transmission. Fill **ONLY** to the full mark on the dipstick, **never** overfill the transmission.

**NOTE:** Always use Cub Cadet hydraulic oil and filters to ensure correct formulation and filtering capacity. Substitute oils and/or filters could affect performance and may cause damage to the transmission.

- Reinsert the oil fill plug/dipstick into the transmission housing and turn clockwise until tight.
- Start the engine and allow it to run for a few minutes. Shut the engine off, then check for leaks and recheck the oil level in the transmission housing.

## CHANGING HYDROSTATIC TRANSMISSION AND HYDRAULIC SYSTEM OIL FILTERS

**NOTE:** *With the exception of the first oil filter change after the 25 hour break-in period, the hydrostatic transmission and hydraulic system oil filters should be changed along with the hydrostatic transmission/hydraulic system oil after every 200 hours of operation.*

### **Initial Break-In Period Filter Change**

During the initial hours of tractor operation, contaminants caused by the normal break-in of internal transmission and hydraulic system components will collect in the oil filters. Because of this, the filters should be changed after the first 25 hours of operation.

Hydro Pump Filter — Part No. 723-3014

Hydraulic System Filter — Part No. 723-0405

**NOTE:** *A large volume of oil may drain from the transmission while performing the 25 hour change of the oil filters. **If collected in a clean container and kept free of debris, this oil may be reused in the transmission/ hydraulic system.***

Perform the INITIAL change of the transmission and hydraulic system oil filters as follows:

- Remove any belly mounted attachments.
- Clean the areas around the hydrostatic transmission and hydraulic system oil filters. Refer to Figure 46.
- Position a CLEAN, suitable container below the hydrostatic transmission filter. See Figure 46.
- Apply a light coating of clean transmission oil to the gasket of the new hydrostatic filter.
- Remove the old hydrostatic filter by turning it counterclockwise, and immediately replace with the new filter. Turn the filter clockwise, by hand, until the gasket contacts the filter base on the transmission housing; then tighten the filter an additional 1/2 to 3/4 turn.

- Position the collection container below the hydraulic system filter. See Figure 46.
- Apply a light coating of clean transmission oil to the gasket of the new hydraulic system filter.
- Remove the old hydraulic system filter by turning it counterclockwise, and immediately replace with the new filter. Turn the filter clockwise, by hand, until the gasket contacts the filter base on the transmission housing; then tighten the filter an additional 1/2 to 3/4 turn.
- Clean the area around the transmission oil fill plug/dipstick to prevent debris from entering the transmission (Refer to Figure 45) and remove the plug.
- Following the instructions previously provided in **CHANGING TRANSMISSION/HYDRAULIC SYSTEM OIL**, refill the transmission with the clean salvaged oil or with new hydraulic oil.
- Reinsert the oil fill plug/dipstick into the transmission housing and turn clockwise until tight.
- Start the engine and allow it to run for a few minutes. Shut the engine off, then check for leaks and recheck the oil level in the transmission housing.

**NOTE:** *If a front end loader, or a loader and backhoe, are in-stalled on the tractor **after the first 25 hours** of operation, it is recommended that the filters again be changed after the first 25 hours of operation with these attachments installed.*

### **Regularly Scheduled Oil Filter Changes**

Change the hydrostatic transmission and hydraulic system oil filters along with the hydrostatic transmission/hydraulic system oil after every 200 hours of operation. Refer to the previous sub-section **CHANGING TRANSMISSION/HYDRAULIC SYSTEM OIL** and follow the instructions for changing the oil and filters.

## CHECKING OIL LEVEL IN FRONT AXLE AND FINAL REDUCTION GEAR CASES.

Check the front axle and final reduction gear case oil levels after every 50 hours of operation. Check the oil level only while the engine is stopped and the tractor is standing on a level surface.

### Check Front Axle Oil

The oil fill plug/dipstick is located on the *left* side of the axle housing. See Figure 47.

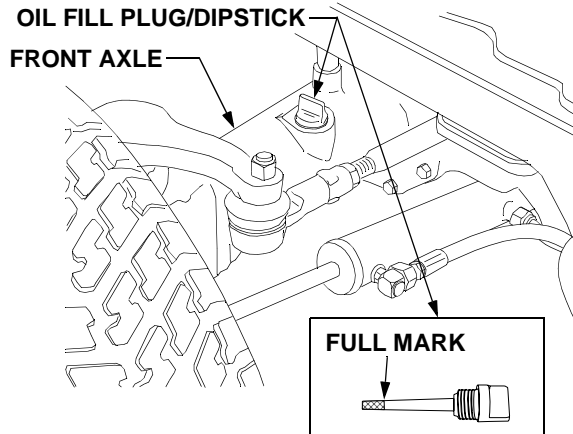

Figure 47

- Clean the area around the oil fill plug/dipstick to prevent debris from entering the axle housing. See Figure 47.
- Turn the oil fill plug/dipstick counterclockwise to unscrew from the axle housing.
- Withdraw the dipstick and wipe it clean, then reinsert and screw in all the way. Unscrew and withdraw again to read the oil level. Always keep the oil level between the bottom and the full mark of the dipstick (See Figure 47).
- If the oil level is low, add only enough *Cub Cadet* Gear Lube to bring the level to the full mark on the dipstick. NEVER overfill the axle housing.
- Reinsert the fill plug/dipstick into the axle housing and turn clockwise to fully tighten.

### Check Final Reduction Gear Case Oil

Check the oil level at the two final reduction gear case fill plugs.

- Locate the fill plugs approximately midway up on the rear of the *right* and *left* gear cases. See Figure 48.
- Remove the fill plugs and check that the oil level is at the bottom edge of the fill port opening.

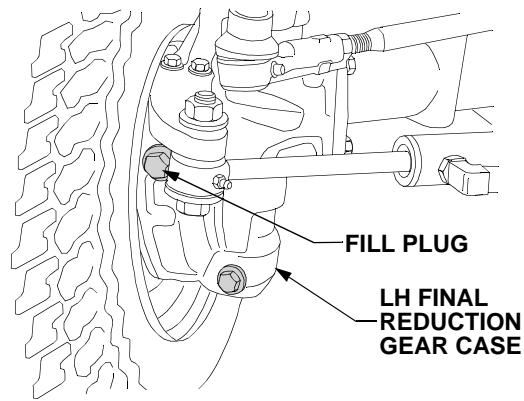

Figure 48

- If the oil level is low, use a funnel with a flexible spout to add enough *Cub Cadet* Gear Lube to bring the level up to the bottom of the fill port.
- Reinstall the fill plug in each gear case.

## CHANGING FRONT AXLE AND FINAL REDUCTION GEAR CASE OIL

Change the front axle and final reduction gear case oil after every 300 hours of operation. The total dry capacity of both gear cases and the axle housing is approximately 81 oz. (2.5 qts.)

Change the front axle and final reduction gear case as follows:

- Operate the tractor for a short period to warm the oil to the normal operating temperature. Place the tractor on a level surface, engage the parking brake, and stop the tractor engine.
- To prevent debris from entering the front axle housing, clean the area around the oil fill plug/dipstick and the axle drain plug located at the center front of the axle. Refer to Figure 47 and Figure 49.

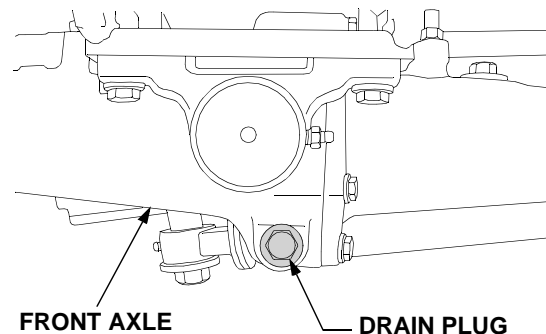

Figure 49

- Place a suitable container beneath the front of the axle housing.
- Remove the oil fill plug/dipstick to help vent the axle, then remove the drain plug and allow the oil to drain into the container. Reinstall the drain plug after draining the oil. See Figure 49.
- Fill the axle with Cub Cadet Gear Lube until the oil level reaches the full mark on the dipstick. Do not over fill the axle housing.
- Reinstall the fill plug/dipstick in the axle housing.
- Move the drain pan underneath either of the final reduction gear cases.
- Remove the fill plug and drain plug from the gear case and drain the oil. See Figure 50. After the oil has drained, reinstall the drain plug.
- Using a funnel with a flexible spout, fill the gear case up to the bottom of the fill port with Cub Cadet Gear Lube. Reinstall the fill plug.

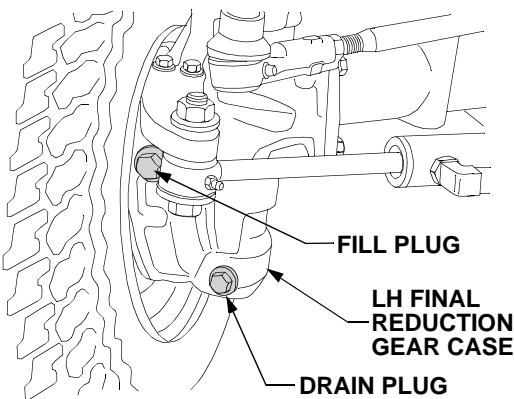

Figure 50

- Repeat the previous three steps to change the oil in the other final reduction gear case.



Dispose of used oil in an environmentally safe manner. If necessary, contact your area EPA office for proper disposal procedures and recycling center locations.

### LUBRICATION OF MAIN DRIVE SHAFT

Lubricate both ends of the main drive shaft after every 50 hours of operation as follows:

- The front end of the drive shaft can be accessed from under the hood, and the rear end by removing the six screws and the center fender cover. The drive shaft can also be accessed from the underside of the tractor. **NOTE:** *It may be necessary to rotate the drive shaft to access the grease fittings.*
- Using a pressure lubricating gun, lubricate the drive shaft with Cub Cadet 251H EP grease.

### LUBRICATION OF FWD DRIVE SHAFT

Lubricate both ends of the FWD drive shaft with Cub Cadet 251H EP grease after every 50 hours of operation. The FWD drive shaft can be accessed from beneath the tractor.

### WHEEL BOLT TORQUE

The front and rear wheel bolts should be retorqued after the first ten hours of operation and every 100 hours thereafter, or if the wheel assembly has been removed. Using a torque wrench, retighten the bolts as follows:

**Rear Wheels**—In a staggered pattern, retorque the rear wheel bolts to 80 ft. lbs.

**Front Wheels**—In a staggered pattern, retorque the front wheel bolts to 55 ft. lbs.

### MAINTENANCE OF THE ROLLOVER PROTECTIVE STRUCTURE (ROPS)

Periodically (at least every six months) visually inspect the ROPS for damage and loose fasteners. If damage is noted, contact your Cub Cadet dealer.

If an accident has occurred which may have damaged the ROPS, have the ROPS thoroughly inspected by your Cub Cadet dealer.



**WARNING:** To ensure the structural integrity of the ROPS to provide operator protection, do not attempt to straighten or weld the ROPS. A damaged ROPS should be replaced.

If the ROPS is removed for any reason, make sure the proper hardware is used to reinstall it, and that the recommended torque values are applied to the fasteners.

When replacing or reinstalling the ROPS, apply Loctite® 242 to the threads of the bolts and torque the bolts to 65 to 70 ft. lbs.

## TIRE MAINTENANCE

Check the tire air pressure after every 50 hours of operation or weekly. Keep the tires inflated to the recommended pressures. Improper inflation will shorten the service life of a tire. See the tire side wall, or the Tire Inflation chart, for proper inflation pressures. Observe the following guidelines:

- Do not inflate a tire above the maximum pressure shown either on the sidewall of the tire or the Tire Inflation chart.
- Do not reinflate a tire that has been run flat or seriously under inflated. Have a qualified tire mechanic inspect and service the tire.



**WARNING: Servicing tires can be dangerous. Whenever possible, trained personnel should service and mount tires.**

If you must service the tires, observe the following safety precautions to avoid an injury or fatality:

- Make certain the rim is clean and free of rust.
- Lubricate the flanges of the rim and beads of the tire with soap solution.



**WARNING: When seating the beads, never inflate a tire over 35 PSI. Inflating a tire with unseated beads beyond 35 PSI could break the bead or rim with sufficient explosive force to cause a serious injury.**

- Inflate the tire to seat the beads. If the tire beads have not seated at or before 35 PSI, allow the tire to deflate. Reposition the tire on the rim, lubricate the tire beads and rim flanges, and reinflate until seated - up to a maximum of 35 PSI.
- After the beads have seated, adjust the inflation pressure to the recommended operating pressure.
- Do not use a damaged rim, or attempt to repair a rim by brazing, welding, or pounding out.

- Make certain the jack used to raise the tractor has a weight capacity adequate for lifting the tractor.
- Place the tractor on a firm, level surface and position jack stands to support the raised tractor while repairing tires.
- DO NOT place any part of your body beneath the tractor or start the tractor engine while the tractor is raised off the ground with a jack.

TIRE INFLATION CHART			
Position	Tread Type	Tire Size	Inflation Pressure
Front	Turf	23 x 9.5-12	10 psi
Rear	Turf	31 x 12-15	15 psi
Front	Indus.	8.5-12	35 psi
Rear	Indus.	10-16.5	45 psi

## TRACTOR STORAGE

If your tractor is not going to be operated for an extended period of time (thirty days to approximately six months), the tractor should be prepared for storage. Store the tractor in a dry and protected location. If stored outside, cover the tractor (including the tires) to protect it from the elements. The procedures outlined below should be performed whenever the tractor is placed in storage.



**WARNING: Never store the tractor with fuel in the tank indoors or in poorly ventilated enclosures, where fuel fumes may reach an open flame, spark or pilot light as on a furnace, water heater, clothes dryer, etc.**

1. Change the engine oil and filter following the instructions provided in **CHANGING THE ENGINE OIL AND FILTER** in **SECTION 5**.
2. Drain and flush the cooling system. Refill with a minimum 50/50 antifreeze and water coolant solution. Use a higher percentage of antifreeze if the tractor will be subjected to temperatures below minus 30° F.

3. Clean the engine and the entire tractor thoroughly.
4. Fill the fuel tank with FRESH high grade Number Two diesel fuel.
5. Remove the glow plugs and pour a small amount of engine oil into each cylinder. Reinstall the glow plugs and slowly crank the engine to distribute the oil.
6. Fully charge the battery, then disconnect the negative cable at the battery to prevent possible discharge. Thoroughly clean the battery. Recharge the battery periodically when in storage.

**NOTE:** *Remove the battery if exposed to prolonged periods of sub-freezing temperatures. Store in a cool, dry location where temperatures are above freezing.*

7. Lubricate all lubrication points.

8. Jack up and block the tractor to remove the weight from the tires if stored for a long period. If not blocked up, reinflate the tires regularly.

**NOTE:** *We do not recommend the use of a pressure washer or garden hose to clean your unit. They may cause damage to electrical components; spindles; pulleys; bearings; or the engine. The use of water will result in shortened life and reduce serviceability.*

#### **REMOVING THE TRACTOR FROM STORAGE**

- Check the engine oil and coolant levels.
- Fully charge the battery and inflate the tires to the recommended pressure.
- Start the engine and allow to idle for a few minutes to ensure engine is operating properly.
- Drive the tractor without a load to make certain all the tractor systems are functioning properly.



---

## SECTION 5: ENGINE INFORMATION AND MAINTENANCE

**Daihatsu L.L.C., the California Air Resources Board (CARB)  
and the United States Environmental Protection Agency (U.S. EPA)  
Emission Control System Warranty Statement  
(Owner's Defect Warranty Rights and Obligations)**

EMISSION CONTROL WARRANTY COVERAGE IS APPLICABLE TO CERTIFIED ENGINES PURCHASED IN CALIFORNIA IN 1995 AND THEREAFTER, WHICH ARE USED IN CALIFORNIA, AND TO CERTIFIED MODEL YEAR 2000 AND LATER ENGINES WHICH ARE PURCHASED AND USED ELSEWHERE IN THE UNITED STATES

### **California And United States Emission Control Defects Warranty Statement**

The California Air Resources Board (CARB), U.S. EPA, and Daihatsu are pleased to explain the Emission Control Systems Warranty on your model year 2000 and later small off-road engine (SORE) engine. In California, new small off-road engines must be designed, built and equipped to meet the State's stringent anti-smog standards. Elsewhere in the United States, new non-road, spark-ignition engines certified for model year 1997 and later, and compression-ignition engines certified for model year 2000 and later, must meet similar standards set forth by the U.S. EPA. Daihatsu must warrant the emission control system on your engine for the period of time listed below, provided there has been no abuse, neglect or improper maintenance of your small off-road engine.

Your emission control system includes such parts as the carburetor, air cleaner, ignition system, muffler and catalytic converter. Also included may be connectors and other emission related assemblies.

Where a warrantable condition exists, Daihatsu will repair your small off-road engine at no cost to you, including diagnosis, parts and labor.

### **Daihatsu Emission Control Defects Warranty Coverage**

Small off-road engines are warranted relative to emission control parts defects for a period of 1,500 hours or two years, whichever first occurs, subject to provisions set forth below. If any covered part on your engine is defective, the part will be repaired or replaced by Daihatsu.

### **Owner's Warranty Responsibilities**

As the small off-road engine owner, you are responsible for the performance of the required maintenance listed in the Operator's Manual. Daihatsu recommends that you retain all your receipts covering maintenance on your small off-road engine, but Daihatsu cannot deny warranty solely for the lack of receipts or for your failure to ensure the performance of all scheduled maintenance.

As the small off-road engine owner, you should however be aware that Daihatsu may deny you warranty coverage if your small off-road engine or a part has failed due to abuse, neglect, improper maintenance or unapproved modifications.

You are responsible for presenting your small off-road engine to an authorized Daihatsu Service Dealer as soon as a problem exists. The undisputed warranty repairs should be completed in a reasonable amount of time, not to exceed 30 days.

If you have any questions regarding your warranty rights and responsibilities, you should contact a Daihatsu Service Representative at 1(800) 759-2744.

### **Daihatsu Emission Control Defects Warranty Provisions**

The following are specific provisions relative to your Emission Control Defects Warranty Coverage. It is in addition to the manufacturer's engine warranty.

1. Warranted Parts — Coverage under this warranty extends only to the parts listed below (the emission control systems parts) to the extent these parts were present on the engine purchased.
  - a. **Fuel Metering System**

For Gasoline	For Diesel
<ul style="list-style-type: none"><li>• Carburetor and internal parts</li><li>• Cold start enrichment system (soft choke)</li><li>• Fuel pump</li><li>• Fuel Filter</li></ul>	<ul style="list-style-type: none"><li>• Injection pump with feed pump</li><li>• Injection nozzle</li><li>• Fuel Filter</li></ul>
  - b. **Air Induction System**
    - Air cleaner
    - Intake manifold

**c. Ignition System**

For Gasoline

- Spark plug(s)
- Ignition coil
- Ignition processor

For Diesel

- Glow plug

**d. Exhaust System**

- Exhaust manifold

**e. Miscellaneous Items Used in Above Systems**

- Vacuum, temperature, position, time sensitive valves and switches
- Electronic controls
- Connectors and assemblies
- Hoses

2. Length of Coverage — Daihatsu warrants to the initial owner and each subsequent purchaser that the Warranted Parts shall be free from defects in materials and workmanship which caused the failure of the Warranted Parts for a period of 1,500 hours or two years, whichever first occurs, from the date the engine is delivered to a retail purchaser.
3. No Charge — Repair or replacement of any Warranted Part will be performed at no charge to the owner, including diagnostic labor which leads to the determination that a Warranted Part is defective, if the diagnostic work is performed at an Authorized Daihatsu Service Dealer. For emission warranty service contact your nearest Authorized Daihatsu Service Dealer as listed in the “Yellow Pages” under “Engines, Gasoline,” “Gasoline Engines,” “Lawn Mowers,” or similar category.
4. Claims and Coverage Exclusions — Warranty claims shall be filed in accordance with the provisions of the Daihatsu Engine Warranty Policy. Warranty coverage shall be excluded for failures of Warranted Parts which are not original Daihatsu parts or because of abuse, neglect or improper maintenance as set forth in the Daihatsu Engine Warranty Policy. Daihatsu is not liable to cover failures of Warranted Parts caused by the use of add-on, non-original, or modified parts.
5. Maintenance — Any Warranted Part which is not scheduled for replacement as required maintenance or which is scheduled only for regular inspection to the effect of “repair or replace as necessary” shall be warranted as to defects for the warranty period. Any Warranted Part which is scheduled for replacement as required maintenance shall be warranted as to defects only for the period of time up to the first scheduled replacement for that part. Any replacement part that is equivalent in performance and durability may be used in the performance of any maintenance or repairs. The owner is responsible for the performance of all required maintenance, as defined in the Operator’s Manual.
6. Consequential Coverage — Coverage hereunder shall extend to the failure of any engine components caused by the failure of any Warranted Part still under warranty.

## ENGINE MAINTENANCE



**WARNING:** Use care when servicing any component in the engine area. If the engine has recently been operated, components will be hot and could cause burns. Allow the engine to cool before servicing.



**WARNING:** Before servicing the engine, place the tractor on a level surface, stop the engine, engage the parking brake, and remove the key from the ignition switch.

## CLEANING THE ENGINE

This tractor has a liquid-cooled engine. Air must be able to circulate freely through the fins of the radiator and the transmission oil cooler. Keep this area free of accumulated dirt and debris to prevent engine overheating, which could possibly cause extensive engine damage.



**WARNING:** Keep the muffler area clean. Before running the engine, remove all combustible debris from the muffler area.

## CLEANING THE RADIATOR SCREEN AND RADIATOR

To remove the radiator screen, lift the hood and carefully lift screen by the center tab. Flush the screen with water to clean its surface. See Figure 51.

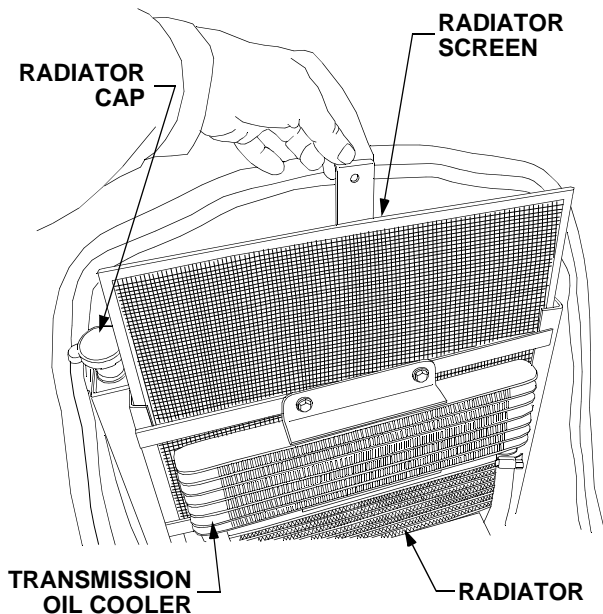

Figure 51

Check the radiator and transmission cooler fins for any accumulation of debris lodged between cooling fins. Blow the debris out using compressed air directed from the fan shroud side of the radiator.

Reinsert the screen, making sure that it is in the slots of the radiator frame.

## CHECKING ENGINE OIL LEVEL

Before each use, the oil level in the engine crankcase should be checked to see that it is filled to the correct level. During the "break in" period for the engine, closely monitor the engine oil level. The oil level should be checked hourly during the first 5 hours of operation.

- Check the oil level only while the engine is stopped and the tractor is level. Clean the area around the oil level dipstick to prevent debris from entering the crankcase. See Figure 52.
- If recently operated, allow the engine to cool and the oil to drain back into the oil pan.
- To check the oil level, release the dipstick handle from the retaining clip, then withdraw the dipstick and wipe it clean. Reinsert the dipstick all the way into the tube before withdrawing it for a true reading.

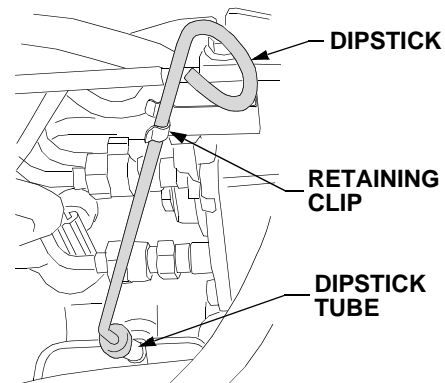

Figure 52

- Always keep the oil level between the full and the add marks on the dipstick. See Figure 53.
- Reinsert the dipstick into the dipstick tube and push firmly into the tube.

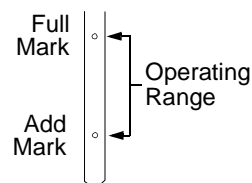

Figure 53

## ADDING ENGINE OIL



**WARNING:** Never overfill the engine crankcase. The engine may overheat and/or damage may result if the crankcase is below the “ADD” mark or over the “FULL” mark on the dipstick. For best results, fill to the “FULL” mark on the dipstick as opposed to adding a given quantity of oil. Always check the level on the dipstick before adding more oil.

Refer to the LUBRICATION TABLE in the **MAINTENANCE SECTION** of this manual to determine the proper type of oil to add to the crankcase for the conditions under which the engine will be operated.

- Place the tractor on a level surface and engage the parking brake. Stop the tractor engine and remove the ignition key.
- Clean the area around the oil filler cap to prevent debris from entering the crankcase. See Figure 54.

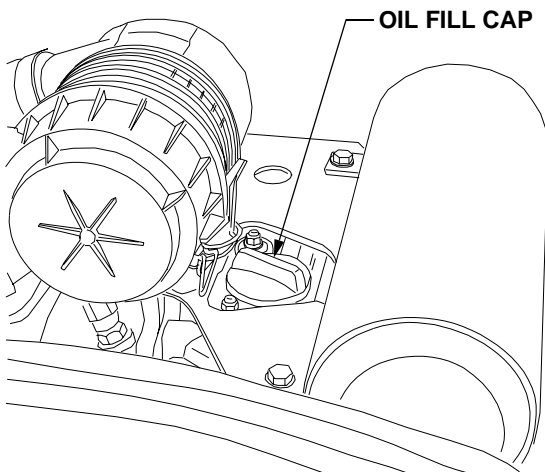

Figure 54

- Turn the oil filler cap counterclockwise to unscrew from the valve cover.
- SLOWLY pour oil into the crankcase until the oil level reaches the “FULL” mark on the dipstick. Refer to Figure 53.
- Insert the oil fill cap into the valve cover and turn clockwise until fully tightened. Reinsert the dipstick into the dipstick tube and push firmly into the tube. Clip the dipstick handle into the retaining clip.

**IMPORTANT:** *The oil fill cap and dipstick must always be installed securely in place when the engine is running. Severe engine damage could result from failure to do so.*

## CHANGING THE ENGINE OIL AND FILTER

The engine oil and oil filter should be changed after the first fifty hours of operation and every 150 hours thereafter. Refer to the LUBRICATION TABLE in the **MAINTENANCE SECTION** of this manual for the quantity of oil needed, and to determine the proper type of oil to use for the conditions under which the engine will be operated.



**WARNING:** Because the engine is run prior to draining the oil, the engine may be hot. Use caution to avoid burning yourself on engine surfaces.

Run the engine for a few minutes to allow the oil in the crankcase to warm up. Warm oil will flow more freely and carry away more engine impurities. Use care to avoid burns from hot oil. While the engine oil is warm, proceed as follows:

- Place the tractor on a level surface and engage the parking brake. Stop the tractor engine and remove the ignition key.
- Clean around the base of the oil filter, the oil filler cap, and the dipstick tube to prevent debris from entering the crankcase.
- Remove the dipstick and oil fill cap from the engine. Refer to Figure 52 and Figure 54.
- Locate the engine drain plug on the *right* of the engine (See Figure 55). Place a suitable container below the drain plug to collect the old oil.

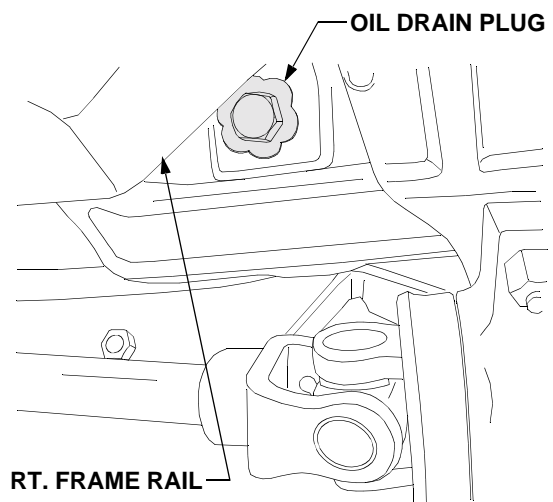

Figure 55

- Turn the drain plug counter-clockwise to remove from the engine.
- Allow the old oil to completely drain from the engine crankcase into the container below.

- Remove the filter by turning it counterclockwise using an automotive type filter wrench to loosen. See Figure 56.

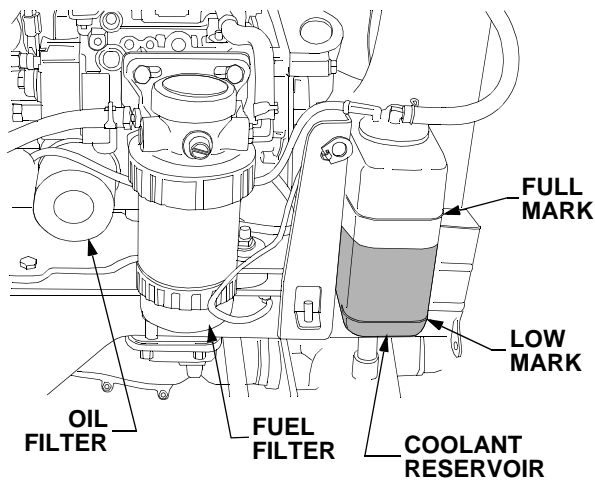

Figure 56

- Reinstall the drain plug in the engine and clean up any residual oil. Refer to Figure 55.
- Apply a light coating of clean oil on the gasket of the new oil filter. Thread the filter on by hand until the gasket contacts the filter mounting surface, then tighten the filter an additional 3/4 turn.
- Refill the crankcase to the "FULL" mark on the dipstick with the appropriate type oil.
- Reinstall the oil fill cap and dipstick.
- Start the engine and run for about 5 minutes. Stop the engine and check for leaks at the oil filter and drain plug.
- Wait 3 minutes and re-check the oil level. If needed, add oil to bring the oil level up to the "FULL" mark.



**WARNING:** Never overfill the engine crankcase. The engine may overheat and/or damage may result. For best results, fill to the "FULL" mark on the dipstick as opposed to adding a given quantity of oil. Always check the level on the dipstick before adding more oil.



Dispose of used oil in an environmentally safe manner. If necessary, contact your area EPA office for proper disposal procedures and recycling center locations.

**IMPORTANT:** *The oil fill cap and dipstick must always be installed securely in place when the engine is running. Severe engine damage could result from failure to do so.*

## CHECKING ENGINE COOLANT LEVEL

Before each use, the engine coolant level in the overflow reservoir should be checked to ensure it is within the operating range. Engine coolant absorbs heat from the engine and transfers the heat to the air flowing through the radiator. If the coolant level becomes low, the engine may overheat and could cause severe damage to the engine.

Use a permanent type antifreeze containing corrosion and rust inhibitors. Dilute the antifreeze with water at a 1:1 ratio to mix the coolant solution (50% antifreeze : 50% water).

**NOTE:** *Distilled water is recommended for the coolant solution IF your tap water has a high mineral content. Minerals cause scaling in the engine and the radiator coolant passages. System efficiency will be greatly reduced over time and severe engine damage may result.*

- Check the coolant level when the engine is cold and the tractor is on a level surface.
- Raise the tractor hood and check the coolant level in the overflow reservoir on the *right* side of the engine. Refer to Figure 56.
- If the coolant level is below the "LOW" mark, remove the cap from the reservoir and add coolant solution to the "FULL" mark.

**NOTE:** *The cooling system is a closed type. Normally, to prevent air from entering the system, the radiator cap should not be removed.*

If the overflow reservoir is empty, the radiator cap should be removed and the coolant level in the radiator checked before adding coolant to the reservoir. If necessary, first refill the system through the radiator filler neck as follows:



**WARNING:** It is dangerous to remove the radiator cap when the system is hot. Allow the system to cool before removing the radiator cap.

- Turn the radiator cap counterclockwise to the first stop to release any pressure. Refer to Figure 51.
- Push downward on the cap and turn counterclockwise until the cap stops then lift cap off.
- Slowly pour coolant into the filler neck until the level reaches the bottom of the filler neck overflow flange.
- Wait a few minutes to allow as much air as possible to escape through the filler neck, then reinstall the radiator cap.
- Fill the overflow reservoir to the "FULL" mark.

- Start the engine and allow it to run for a short period. Stop the engine.
- Recheck the coolant level in the overflow reservoir and refill as needed. Reinstall the reservoir cap.

### INSPECTION OF COOLING SYSTEM HOSES

Check the cooling system hoses and fan belt for any cracks or deterioration after every 100 hours of operation. Check for loose hose connections. Replace any damaged hoses and tighten any loose connections. Replace a worn or damaged fan belt.

### CHANGING THE ENGINE COOLANT

The engine coolant should be drained and replaced with new coolant solution yearly.

The dry capacity of the cooling system is approximately 5.3 Qts. Dilute the antifreeze with water at a 1:1 ratio to mix the coolant solution (50% antifreeze : 50% water).

Change the engine coolant as follows:

- Drain the coolant when the engine is cold.
- Place the tractor on a level surface and raise the tractor hood.
- Slide the overflow reservoir upward and off the reservoir bracket to access the radiator drain plug.
- Locate the radiator drain plug in the lower *right* rear corner of the radiator. See Figure 57.

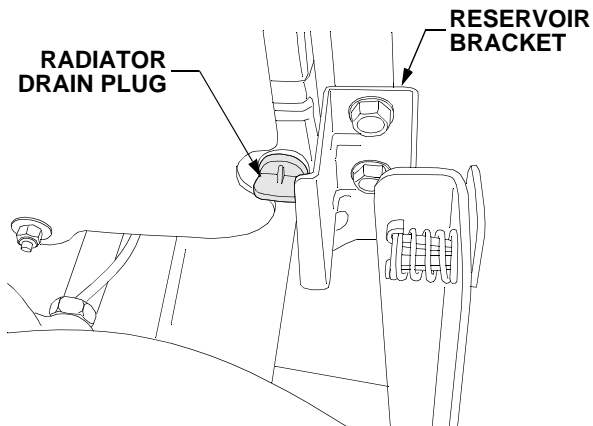

Figure 57

- Place a suitable container beneath the drain plug and remove the cap from the overflow reservoir.
- Turn the drain plug counterclockwise to remove. Allow as much of the old coolant as possible to drain from the system.



Coolant is a toxic substance. Dispose of in an environmentally safe manner. Contact your area EPA office for proper disposal methods and recycling center locations.

- Reinstall the drain plug and turn clockwise until fully tightened.
- Turn the radiator cap counterclockwise to the first stop, then push downward on the cap and turn counterclockwise to remove. Refer to Figure 51.
- In stages, SLOWLY pour the coolant solution into the filler neck, allowing as much air as possible to escape through the neck. Fill to the overflow flange of the filler neck.
- Wait a few minutes to allow air to escape through the filler neck and refill as needed, then reinstall the radiator cap.
- Fill the overflow reservoir to the "FULL" mark.
- Start the engine and allow it to run for a short period. Stop the engine.
- Recheck the coolant level in the overflow reservoir and refill as needed. Reinstall the reservoir cap.

### CHANGING THE AIR CLEANER

Check the air cleaner daily or before starting the engine. Check for loose or damaged components and check the condition of the filter element. Remove any buildup of dirt and debris in the air cleaner housing.

Replace the paper air cleaner element after every 300 hours of operation. More often if operating the tractor under extremely dusty conditions.

Check and replace the air cleaner element as follows:

- Unlock the clamps to remove the air cleaner housing cover. See Figure 58.

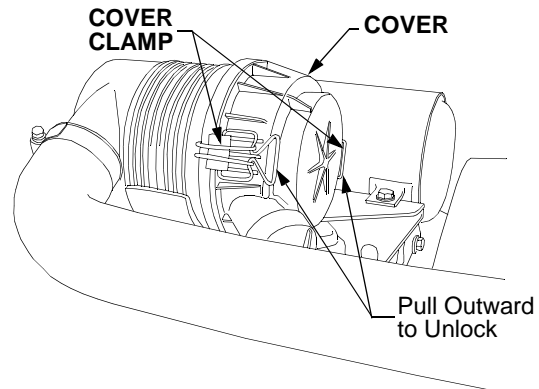

Figure 58

- Pull the air cleaner element from the housing. See Figure 59.

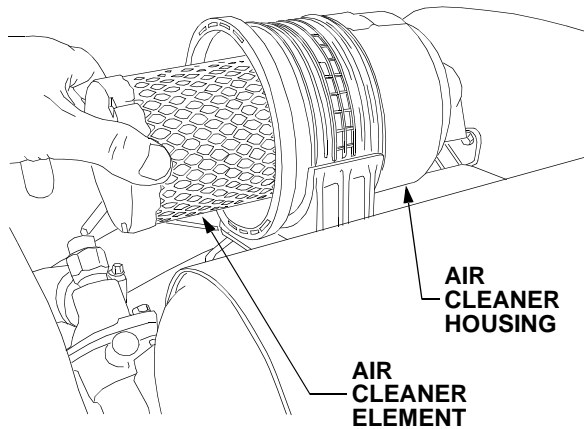

Figure 59

- Lightly blow or brush loose debris from the air cleaner element. Clean any debris from the housing.
- Inspect the paper pleats of the cleaner element for damage and dirt. Inspect the sealing surface on the inner end of the element for deterioration or damage. Replace a damaged or dirty air cleaner element.
- Push the new air cleaner element fully into the housing.
- Position the cover on the housing. Hook the two clamps onto the rim of the housing and lock the clamps. Refer to Figure 58.

**IMPORTANT:** A clean and properly installed air cleaner element significantly contributes to prolonging engine life.

### SERVICING THE FUEL FILTER



**WARNING:** Do not service the fuel filter when tractor is hot or near any source of ignition. Allow the tractor to cool.

The tractor is equipped with an in-line fuel filter located on the *right* side of the engine. Regularly check the cup at the bottom of the fuel filter for condensate water that has separated from the diesel fuel (Refer to Figure 60). Drain the filter cup as needed, or after every 100 hours of operation. Replace the fuel filter after every 600 hours of operation.



Diesel fuel is a toxic substance. Dispose of in an environmentally safe manner. Contact your area EPA office for proper disposal methods and recycling center locations.

### Draining The Fuel Filter Cup

- Stop the engine.
- Place a suitable container beneath the filter cup. See Figure 60.

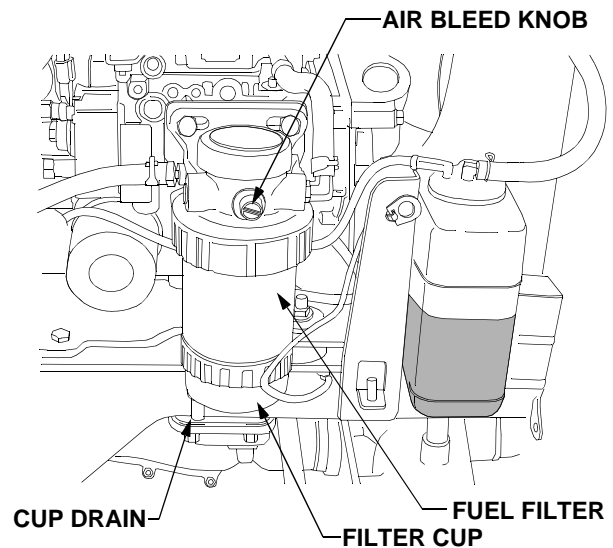

Figure 60

- Turn the cup drain counterclockwise to open. Allow the water at the bottom of the cup to drain until only diesel fuel remains in the cup. See Figure 61.
- Turn the cup drain clockwise to close. See Figure 61.

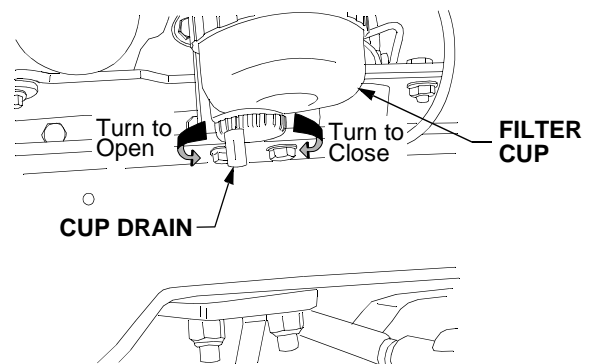

Figure 61

- Slowly turn the air bleed knob counterclockwise until fuel refills the filter cup and begins to seep out around the bleed knob. Turn the air bleed knob clockwise to close. Refer to Figure 60.

## Changing The Fuel Filter

Replace the fuel filter cartridge after every 600 hours of operation.

**NOTE:** *There is no shut off valve in fuel system. To stop the flow of fuel while replacing the filter, it will be necessary to carefully clamp the fuel line between the fuel tank and the filter.*

- Place a suitable container beneath the filter cup.
- Clamp the fuel line just to the rear of the fuel filter. Refer to Figure 62.
- Open the cup drain and drain the filter cup into the container below. Close the cup drain. Refer to Figure 61.
- Grasp the filter cup ring and turn counterclockwise (as viewed from the bottom of the cup) to unscrew the cup from the filter cartridge. See Figure 62.

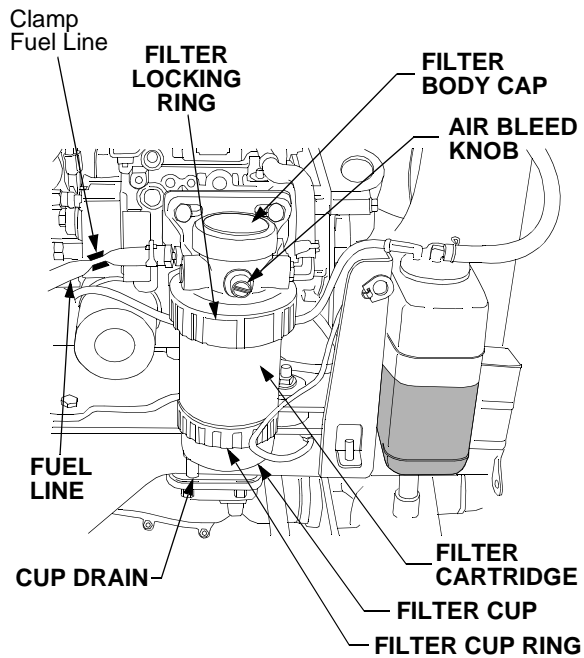

Figure 62

- Turn the filter locking ring approximately 1/4 turn counterclockwise (as viewed from bottom) to unlock. Refer to Figure 62.
- Pull the filter cartridge straight downward to remove. DO NOT try to turn the filter.
- Remove the locking ring from the old filter and slide onto the new one.
- Locate the projection on the upper rim of the new filter cartridge and align with the notch in the filter body.
- Push the new filter cartridge fully up into the filter body.
- Position the locking ring and turn it clockwise to secure the filter cartridge.  
**NOTE:** *If the cartridge is not fully up into the filter body, the locking ring will not turn. Push the cartridge further up into the body.*
- Thread the filter cup up onto the new filter cartridge and fully tighten.
- After checking that the filter cup and locking ring are properly installed and the cup drain is closed, remove the clamp from the fuel line.
- The filter cup should begin to fill with diesel fuel.
- Slowly turn the air bleed knob counterclockwise until fuel refills the cup and begins to seep out around the bleed knob. Turn the air bleed knob clockwise to close. Refer to Figure 62.
- Remove the catch container and properly dispose of the diesel fuel.
- Start and run the tractor's engine for a short period to fully bleed any residual air from the filter, fuel lines, and injection pump.



**WARNING:** Never loosen or remove the filter body cap (Refer to Figure 62). Diesel fuel will pour quickly from the loosened cap. Also, the cap O-ring may be damaged when the cap is retightened, causing continued leakage of flammable fuel.



---

## SECTION 6: SPECIFICATIONS

### Engine

Manufacturer	Diahatsu
Horsepower	26
Cylinders	3 OHC
Cooling System	Liquid
Bore	2.834 in. (72 mm)
Stroke	3.07 in. (78 mm)
Displacement	58.1 cu. in. (953 cc)
Low Idle Speed	1200 rpm
High Idle Speed	3600 rpm
Valve Clearance (Cold)	
Intake	.008 in. (0.2 mm)
Exhaust	.008 in. (0.2 mm)
Crank Case Capacity (With Filter)	3.5 qts. (3.3 L)

### Cooling System

Type	Pressure System, Thermostat Bypass, Impeller Type Pump
Thermostat:	
Start to Open	175° F (80° C)
Fully Open	195° F (90° C)
Radiator Cap	13 psi
Capacity	5.3 qts. (5.0 L)

### Electrical System

Charging System	Alternator
Capacity	30 Amp Regulated
Battery	12 Volt / 500 cca
Starter Motor	Solenoid

### Fuel System

Fuel Tank Capacity	6 gal. (22.7 L)
Fuel Type	Diesel Fuel
Fuel Filter	In-line
Fuel Pump	Electrical

### Transmission

Type	Hydrostatic
Drive	On Demand 4WD
Transmission Oil	Cub Cadet Hydraulic/Transmission Fluid
Transmission Capacity (Includes Hydraulics)	6.5 gal. (24.6 L)
Front Axle Oil	Cub Cadet Gear Lube-135 H.E.P.
Front Axle Capacity (Includes RH and LH Final Drives)	2.5 qts. (2.4 L)
Shift Range	Hi/Lo
Forward Travel Speed	
Hi Range	Forward — 0 to 11.0 mph Reverse — 0 to 5.5 mph
Lo Range	Forward — 0 to 6.4 mph Reverse — 0 to 3.2 mph
Differential Lock	Foot Pedal Control

---

## SPECIFICATIONS

### Hydraulic Lift System

Type .....	Auxiliary Pump-Gear
Control .....	Position Control Lever
Pump Capacity .....	8 gal./min.
Maximum Pressure .....	1500 psi

### Brakes

Type .....	Dry Shoe/Drum
Parking Brake .....	Hand Operated Lever

### Steering

Type .....	Hydrostatic Power
Turning Radius .....	30 in.

### Power Take-Off

Type .....	Electric Clutch
Speed	
Rear .....	540 rpm
Mid/Front (Optional) .....	2000 rpm
Shaft Size	
Rear .....	1.375 in. (35 mm)
Mid .....	1.0 in (25.4 mm)
Horse Power at PTO .....	21

### Hitch System

Type .....	Three Point, Category 1
Capacity @ 24" Behind Hitch .....	950 lbs.
Maximum Height .....	31 in.
Cylinder Type .....	Single Acting

### Tires

Turf	
Front .....	23 x 9.5-12
Rear .....	31 x 12-15
Industrial	
Front .....	23 x 8.5
Rear .....	12 x 16.5

### General Dimensions

Overall Length (w/o Hitch) .....	91 in.
Overall Length (w/Hitch) .....	109 in.
Overall Width .....	48 in.
Overall Height (w/o ROPS) .....	56 in.
Overall Height (w/ROPS) .....	82 in.
Wheelbase .....	58 in.
Minimum Ground Clearance .....	10 in.
Weight w/ROPS .....	1728 lbs.

## SECTION 7: OPTIONAL EQUIPMENT AND ACCESSORIES

When purchasing your tractor, you probably had it equipped for your particular needs at that time. You may later wish to obtain additional equipment or accessories to perform other tasks. Refer to the chart below for a list of optional equipment and accessories currently available through your *Cub Cadet* dealer.

DESCRIPTION	MODEL NUMBER
Backhoe Bucket — 8"; 12"; 16"; 18"; or 24"	590-469-100 thru 590-473-100
Front End Loader <sup>(1)(7)</sup>	590-610-100
Front Hitch Kit <sup>(3)</sup>	590-611-100
Backhoe <sup>(2)</sup>	590-612-100
54" Mower Deck	590-613-100
60" Mower Deck	590-614-100
60" Front Dozer Blade <sup>(4)</sup>	590-615-100
Tractor Cab	590-617-100
54" Snow Thrower <sup>(5)</sup>	590-619-100
Hydraulic Valve Kit for Loader	590-620-100
Sub Frame Kit for Backhoe	590-621-100
Angle Kit - Front Hitch <sup>(6)</sup>	590-623-100
PTO Kit - Front <sup>(6)</sup>	590-624-100
Hydraulic Valve Kit	590-625-100
60" Rear Blade	590-626-100
48" Box Blade	590-627-100
Post Hole Auger	590-628-100
60" Rotary Tiller <sup>(7)</sup>	590-660-100
72" Rotary Tiller <sup>(7)</sup>	590-662-100
48" Rotary Cutter <sup>(7)</sup>	590-630-100
60" Finish Mower <sup>(7)</sup>	590-631-100
60" Landscape Rake	590-632-100
Deluxe Suspension Seat	590-491-100
Slow Moving Vehicle (SMV) Sign	759-04005
Front Weight Bracket/Bumper	590-490-100
Rear Work Light	759-04007
Engine Coolant Heater	759-04003
Lock-out for Mid Mount Decks	759-04004

- (1) Requires hydraulic valve kit 590-620-100
- (2) Requires front end loader 590-610-100; sub frame kit 590-621-100; and choice of available buckets 590-469-100 thru 590-473-100.
- (3) Requires hydraulic valve kit 590-625-100
- (4) Requires front hitch kit 590-611-100. Angle Kit, 590-623-100, optional
- (5) Requires front hitch kit 590-611-100 and front PTO kit 590-624-100
- (6) Requires front hitch kit 590-611-100.
- (7) See TRACTOR WEIGHTING in SECTION 2: OPERATION



**LIMITED WARRANTY  
FOR CUB CADET COMPACT TRACTORS  
AND CUB CADET ATTACHMENTS**

Proper maintenance of your Cub Cadet equipment is the owner's responsibility. Follow the instructions in your owner's manual for correct lubricants and maintenance schedule. Your Cub Cadet dealer carries a complete line of genuine Cub Cadet parts and quality lubricants and filters for your equipment's engine, transmission, chassis and attachments.

This limited warranty covers any defect in materials or workmanship in your Cub Cadet compact tractor and Cub Cadet attachments from the date of purchase for the first user purchaser.

COMPACT TRACTOR (less the power line) ..... ONE YEAR OR 1500 HOURS (whichever is first)

**POWER LINE:**

NON-COMMERCIAL ..... TWO YEARS OR 1500 HOURS (whichever is first)

COMMERCIAL ..... ONE YEAR OR 1500 HOURS (whichever is first)

BATTERY ..... ONE YEAR PRORATED WITH 100% REPLACEMENT  
DURING THE FIRST 3 MONTHS

CUB CADET ATTACHMENTS ..... ONE YEAR

Commercial use is defined as either having hired operators or used for income producing purposes. In no event will we be responsible for loss of use, loss of profit, loss of or damage to crops, inconvenience, commercial loss or other incidental or consequential damages whatsoever.

The power line is defined as (and is limited to):

- |  |                                  |
|--|----------------------------------|
| Cylinder Block                                 | Transmission Case or Center Case |
| Cylinder Head                                  | Differential Housing             |
| (Front) Gear Case                              | Final Drive Case                 |
| Oil Pan  | Front Axle Case                  |
| Clutch Housing and all Parts Contained Therein | Mid and Rear PTO Output Shafts   |

We will replace or repair any part or parts without charge through your Authorized Cub Cadet Compact Tractor Dealer.

**ITEMS NOT COVERED**

The warranty does not cover routine maintenance items such as lubricants, filters (oil, fuel, air and hydraulic), cleaning, tune-ups, brake and/or clutch inspection, adjustments made as part of normal maintenance, blade sharpening, set-up, abuse, accident and normal wear. It does not cover incidental costs such as transporting your equipment to and from the dealer, telephone charges or renting a product temporarily to replace a warranted product. Specific items not covered are: lamp bulbs, injection nozzles, fuel injection pumps, glow plugs, strainers, fuses, brake linings, clutch facings, clutch discs, coolant, rubber products, glass products, plastic products, packings, belts and damage caused by use in an application for which the product is not designed or any other misuse, neglect, incorporation or use of unsuitable attachments or parts, unauthorized alteration, improper installation, or any causes other than defects in material or workmanship of the product.

There is no other express warranty.

**HOW TO OBTAIN SERVICE**

Contact your authorized Cub Cadet servicing dealer who sold you your Cub Cadet equipment. If this dealer is not available, see the Consumer Yellow Pages under "lawn mowers" for the name of a dealer near you.

If you need further assistance in finding an authorized Cub Cadet servicing dealer, contact:

**CUB CADET LLC  
POST OFFICE BOX 361131  
CLEVELAND, OHIO 44136-0019**

**HOW DOES STATE LAW APPLY?**

This limited warranty gives you specific legal rights, and you may also have other rights which vary from state to state.

**CHANGES**

Cub Cadet LLC reserves the right to make changes in the design and other changes in its products at any time without notice and without incurring any obligation to product previously manufactured or purchased.