



# Installation and Operation Manual

## **SPECIALITY OVENS**

Stone Hearth Oven  
*Radiant Flame, Gas-Fired Models*



## **TRAILERED MODELS**

### **MS-5**

WS-MS-5-RFG-(IR)-LP

### **BISTRO 4355**

WS-BL-4355-RFG-LP



**Wood Stone**

**wood stone corporation**  
1801 w. bakerview rd.  
bellingham, wa 98226 usa

tf. 800.988.8103  
t. 360.650.1111  
f. 360.650.1166

**woodstone-corp.com**  
Revised January 2014  
Doc no: M0055.00

### TABLE OF CONTENTS

TRAILERED OVENS . . . . .3  
CAUTIONS AND WARNINGS . . . . .4  
MS-5 SPECIFICATIONS . . . . .6  
BL-4355 SPECIFICATIONS . . . . .7  
INSTALLATION CLEARANCES . . . . .8  
VENTING . . . . .9  
PROPANE SYSTEM . . . . .10  
GAS SPECIFICATIONS . . . . .11  
ELECTRICAL SPECIFICATIONS . . . . .12

**MS-5 OPERATION**

MS-5 CONTROLLER . . . . .13  
MS-5 INITIAL START-UP . . . . .14  
MS-5 DAILY OPERATION . . . . .15

**BL-4355 OPERATION**

BL-4355 CONTROLLER . . . . .16  
BL-4355 INITIAL START-UP . . . . .17  
BL-4355 DAILY OPERATION . . . . .18  
FLAME HEIGHT CONTROL . . . . .19  
CLEANING . . . . .20  
PERIODIC THERMAL CLEANING . . . . .21  
TROUBLESHOOTING . . . . .22  
MS-5 OPERATIONAL SEQUENCE . . . . .23  
BL-4355 OPERATIONAL SEQUENCE . . . . .25  
MS-5 ELECTRICAL DIAGRAM . . . . .26  
BL-4355 ELECTRICAL DIAGRAM . . . . .28  
LIMITED WARRANTY . . . . .29



### INSTALLATION AND OPERATION MANUAL FOR THE WOOD STONE TRAILER OVENS

STONE HEARTH COOKING EQUIPMENT

TRAILER MOUNTED GAS-FIRED OVEN

WS-MS-5-RFG-(IR)-TR-LP MODELS (INCLUDES NAPLES MODELS)

WS-BL-4355-RFG-TR-LP

ADDITIONAL COPIES AVAILABLE UPON REQUEST



WS-MS-5-RFG-IR-TR-LP



WS-BL-4355-RFG-TR-LP



### INSTALLATION AND OPERATION MANUAL FOR WOOD STONE TRAILERED OVENS PROPANE (LP) FUELED STONE HEARTH OVEN

#### RETAIN THIS MANUAL FOR FUTURE REFERENCE

Additional copies of this manual and prompt responses to service/maintenance questions are available from Wood Stone @ 1-800-988-8103.

#### READ ALL INSTRUCTIONS BEFORE INSTALLING AND USING THIS APPLIANCE

Please read this entire manual before you install the oven. Failure to follow instructions may result in property damage, bodily injury or even death. Contact your local building or fire officials about restrictions and installation inspection in your area.

**IMPORTANT:** Consult your local gas supplier for a statement outlining a procedure to be followed in the event you smell gas. Post the statement in a prominent location.

**FOR YOUR SAFETY:** Do not store or use gasoline or other flammable vapors or liquids in the vicinity of this or any other appliance.

**POUR VOTRE SÉCURITÉ:** Ne pas entreposer ni utiliser d'essence ou d'autres vapeurs de liquides inflammables ou des liquides dans les environs de ce ou de tout autre appareil.

**IMPORTANT:** It is recommended that this oven be installed, maintained and serviced by authorized professionals. When his oven is not properly installed, a fire may result. To reduce the risk of fire, follow the installation instructions.



**A MAJOR CAUSE OF OVEN RELATED FIRES IS A FAILURE TO MAINTAIN REQUIRED CLEARANCES TO COMBUSTIBLE MATERIAL. IT IS OF UTMOST IMPORTANCE THAT THIS OVEN BE INSTALLED ONLY IN ACCORDANCE WITH THESE INSTRUCTIONS.**

**DISCONNECT POWER TO THE OVEN BEFORE SERVICING OR CLEANING.  
NO ATTEMPT SHOULD BE MADE TO OPERATE THIS APPLIANCE DURING A POWER FAILURE**

**WARNING:** Improper installation, adjustment, alteration, service or maintenance can result in property damage, injury or death. Read the installation, operation and maintenance instructions thoroughly before installing or servicing this equipment.

**AVERTISSEMENT:** L'installation, le réglage, la modification, la réparation ou l'entretien incorrect de cet appareil peut causer des dommages matériels, de blessures ou la mort. Lire attentivement les instructions d'installation, de fonctionnement et d'entretien avant de procéder à son installation ou entretien.

### SAVE THE INSTRUCTIONS

Wood Stone's gas-fired ovens have been tested and approved by Intertek Testing Services, and are ETL Listed to ANSI Z83.11b - 2009, CSA 1.8b-2009 and to NSF/ANSI Standard 4 - 2009.





### Plan view

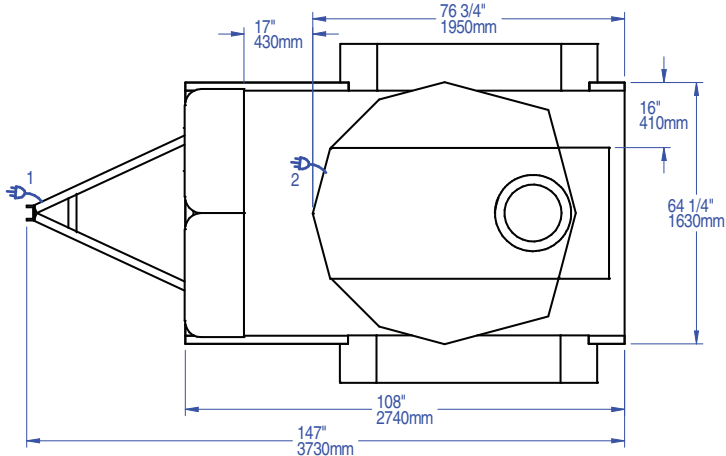

 Air intake:  
Do not cover

 Must be left  
removable for service

**Shipping weight: 5,000 lbs.**

\* Dimensions shown are as shipped. Due to loading, tire pressure and terrain, these dimensions may vary.

### Side view

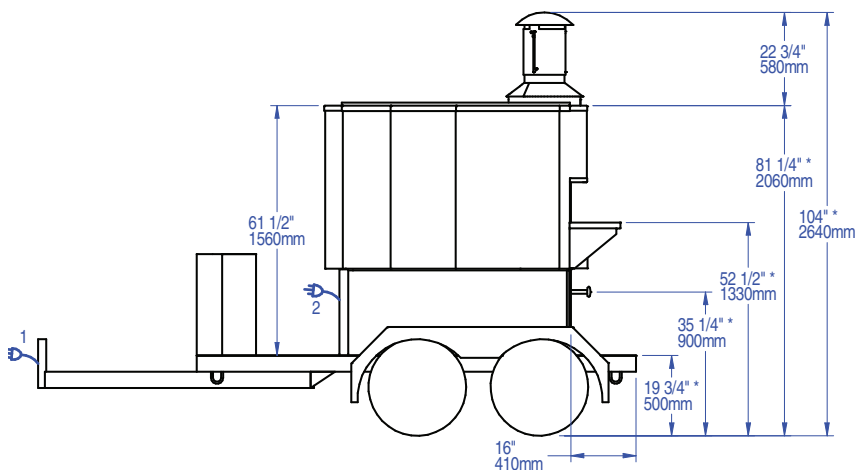

### Front view

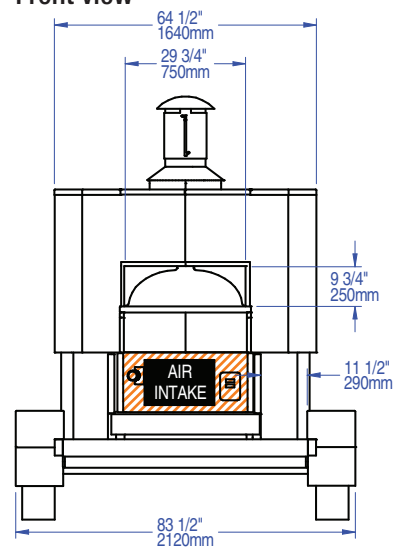

### UTILITIES SPECIFICATIONS

**Gas**  
Self-contained Propane (LP)  
RFG: 94,000 BTU/hr  
RFG-IR: 159,000 BTU/hr

**Electrical**   
(1) At trailer: Power cord 12 VDC  
7-pin receptacle  
(2) At oven: 120 VAC, 1.1 A, NEMA  
L5-15 plug

**Venting**  
Self-contained. For outdoor use only in well ventilated areas.  
No additional venting required.



**This oven is for outdoor use only.** It is equipped with an oven mounted collapsible flue which must be raised before operating the oven. To raise the flue, twist clockwise slightly to unlock it, then raise it up and twist clockwise again to lock the flue into position. Before transporting the oven, lower the flue and lock it in place. Raise slightly and twist counterclockwise to release, lower the flue, then twist counterclockwise to lock into place.

**WARNING: FLUE WILL BE HOT AFTER USE.** Make sure the flue has had sufficient time to cool before attempting to lower it. If the flue is still hot, wear gloves to prevent the chance of burns.

Inspect flue regularly and remove any residues before they accumulate.

If cleaning is necessary, the flue can be accessed through the oven doorway. **Allow the oven to cool.** Place cardboard, sheet pans or towels in the oven doorway to prevent cleaning solution from contacting the oven floor (hearth). Use a mild soap solution mixed with hot water and a long handled brush to clean the flue pipe. Wipe up any cleaning solution that may have contacted the oven floor.

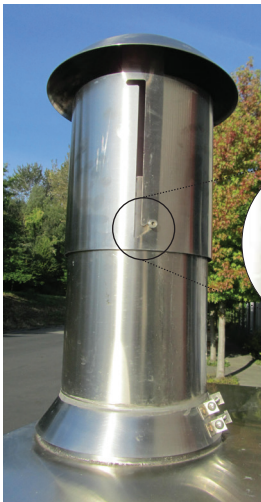

Flue extended and locked.



Flue collapsed.



Flue collapsed and locked.



Plan view

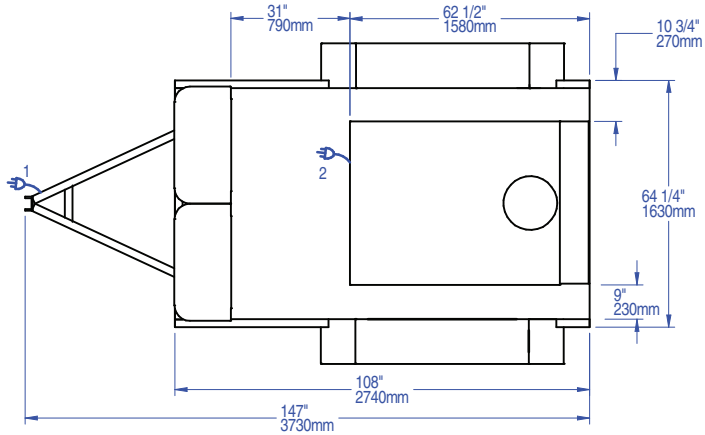

 Air intake:  
Do not cover

 Must be left  
removable for service

**Shipping weight: 4,000 lbs.**

\* Dimensions shown are as shipped. Due to loading, tire pressure and terrain, these dimensions may vary.

Side view

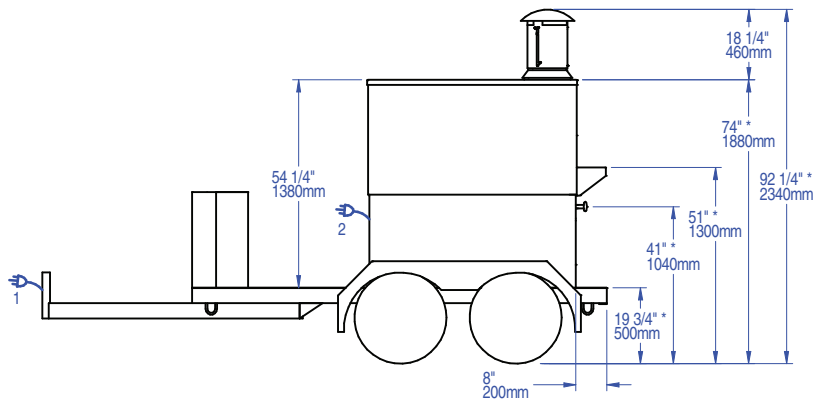

Front view

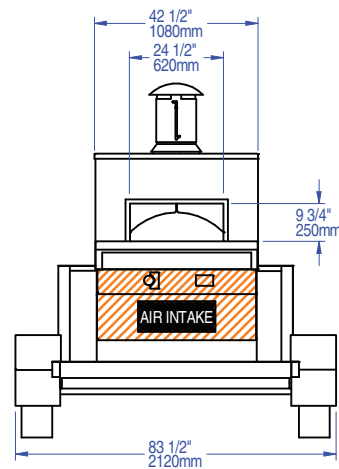

### UTILITIES SPECIFICATIONS

#### Gas

Self-contained Propane (LP)  
68,000 BTU/hr

#### Electrical

(1) At trailer: Power cord 12 VDC  
7-pin receptacle  
(2) At oven: 120 VAC, 2 A, NEMA  
L5-15 plug

#### Venting

Self-contained. For outdoor use only in well ventilated areas.  
No additional venting required.





**IF THIS OVEN IS NOT PROPERLY INSTALLED A FIRE MAY RESULT. TO REDUCE THE RISK OF FIRE, FOLLOW THESE INSTALLATION INSTRUCTIONS. A MAJOR CAUSE OF OVEN RELATED FIRES IS FAILURE TO MAINTAIN REQUIRED CLEARANCES (AIR SPACES) TO COMBUSTIBLE MATERIALS. IT IS OF UTMOST IMPORTANCE THAT THIS OVEN BE INSTALLED ONLY IN ACCORDANCE WITH THESE INSTRUCTIONS.**



**WARNING:** Installation and servicing of this product could expose you to glasswool/ceramic fibers as well as calcium silicate dust. ALWAYS WEAR RESPIRATORY AND EYE PROTECTION WHEN INSTALLING OR SERVICING THIS APPLIANCE. Please read this entire manual before you install the oven. Failure to follow instructions may result in property damage, bodily injury or even death. Contact your local building or fire officials about restrictions and installation inspection in your area.

### CLEARANCES

The Wood Stone gas-fired oven must have a minimum 1" clearance to combustibles from all sides, 14" clearance to combustibles from the top and 0" clearance to non-combustible materials.

**WARNING:** Do not pack required air spaces with insulation or other materials.



Gas-fired Wood Stone Trailer Ovens come equipped with a self-contained LP gas system onboard the trailer. For safe operation of the LP gas system follow the guidelines below.

1. The oven comes equipped with four 30 lbs. capacity cylinders (tanks), grouped as 2 banks of cylinders. Each bank has a tank change over valve, and the 2 banks are intended to be run at the same time to help minimize icing of the cylinders. If replacing a cylinder, it must be constructed and marked in accordance with the specifications for propane cylinders of the U.S. Department of Transportation (DOT) or CAN/CSA B339.
2. This oven is intended only for outdoor use, or in a well ventilated space. The oven is not intended for use in a building, garage or any other enclosed area.
3. To remove a cylinder, make sure any open flames nearby are extinguished. Turn off the valve on the cylinder. Unscrew the hose from the cylinder. Loosen the clamp that secures the cylinders to the trailer and remove the cylinder. Complete these steps in reverse to install the new cylinder.
4. All gas connections should be inspected and leak checked at least yearly. To leak check, first extinguish all open flames close by. Before turning the oven gas supply on, visually inspect all hoses, connections and pipe joints for signs of damage. Check tightness of all connections. Check all piping beneath the oven as well. Then turn on the gas supply at the cylinder(s). Daub an approved leak check solution or mild soap solution on to all gas connections and piping joints to check for leaks. Once the leak check has been completed, make sure to wipe off the leak check/soap solution so that no residue is left on the hoses and piping.
5. Cylinders should be secured in the holders provided on the trailer when transporting the unit. Storing or transporting cylinders in compartments or other locations not intended for cylinder storage could lead to an explosion, fire or personal injury.
6. Do not place propane cylinders in a high heat area such as a closed car, trunk or direct sunlight.
7. Turn off the gas supply at the cylinders when the oven is not in use, and when transporting the oven. If storing the oven indoors, the propane cylinders must be disconnected and removed from the appliance. Cylinders must be stored outdoors, not in a building, garage or any other enclosed area, in a well ventilated area out of reach of children. The dust cap must be installed on the tank valve outlet when the tank is disconnected from the appliance.
8. Visually inspect hoses and regulators for damage before each use. If it is evident the hose is cut or showing excessive abrasion or wear, it must be replaced prior to the oven being put into operation. If any components are damaged, they must be replaced before using the appliance. Use only the regulator, hose and hose assemblies supplied by Wood Stone. If a regulator or hose needs to be replaced, replace only with a part of equal size and ratings. Contact Wood Stone.
9. The transportation and storage of gas cylinders must be in accordance with ANSI/NFPA 58, Storage and Handling of Liquid and Petroleum Gases, or CSA B149.1, the Natural Gas and Propane Installation Code.
10. Do not operate this appliance if the outdoor temperature is below  $-40^{\circ}\text{F}$ , or  $-40^{\circ}\text{C}$ . When transporting or using the oven in freezing conditions, keep the propane regulator vents clear of ice, snow or slush.



SV-1 is the gas control valve that operates the infrared (IR) underfloor burner (only on MS-5-RFG-IR model). It is located beneath the oven at the front of the IR burner.

SV-2 is the gas control valve that operates the interior radiant burner. On the MS-5 oven, the valve is located beneath the oven at the rear, towards the side where the radiant burner is located. On the Bistro 4355 oven, the valve is located on the back of the control box, beneath the oven.

The manifold pressure test port for the radiant burner is a 1/8" NPT plugged tapping located at the base of the T-junction between the SV-2 and the radiant/interior burner.

The burner manifold pressure has been adjusted and tested at the factory. A variety of factors can influence this pressure, so be sure to test the burner manifold pressure and adjust the valve as necessary to achieve the specified pressure. **NOTE:** The gas valve is shipped in the ON position.

**This oven requires no modifications or adjustments for use at high altitudes.**

Factory specified individual burner manifold pressures and BTU/hr rates for RFG-IR models equipped to burn Propane (LP).

Model	SV-1	SV-2	Model	BTU/hr Input Rate
WS-MS-5-RFG-TR-LP	n/a	8"	WS-MS-5-RFG-(NAP)-TR-LP	94,000
WS-MS-5-RFG-IR-TR-LP	9"	8"	WS-MS-5-RFG-IR-(NAP)-TR-LP	159,000

Factory specified individual burner manifold pressures and BTU/hr rates for RFG models equipped to burn Propane (LP).

Model	SV-1	SV-2	Model	BTU/hr Input Rate
WS-BL-4355-TR-LP	N/A	9"	WS-BL-4355-TR-LP	68,000

Wood Stone recommends that inspection and maintenance of the burners and gas piping connections of this appliance be performed at regularly scheduled intervals and only by professional gas appliance service agencies.

### GAS CODE LIMITATIONS

The installation of this appliance must conform with local codes, or in the absence of local codes, with the National Fuel Gas Code, ANSI Z223.1 or the Natural Gas installation Code CAN/CGA-B149.1 as applicable.

The appliance and its individual shutoff valve (supplied by others) must be disconnected from the gas supply piping system during any pressure testing of that system at test pressures in excess of 1/2 psi (3.45 kPa).

The appliance must be isolated from the gas supply piping system by closing its individual manual shutoff valve (supplied by others) during any pressure testing of the gas supply piping system at test pressure, equal to or less than 1/2 psi (3.45 kPa).



### OVEN ELECTRICAL RATINGS

WS-MS-5-RFG-(IR)-TR, 2 A

WS-BL-4355-TR, 2 A

### ELECTRICAL CODE LIMITATIONS

**Electrical grounding:** This appliance must be electrically grounded in accordance with local codes, or in the absence of local codes, with the National Electrical code, ANSI/NFPA 70 or the Canadian Electrical Code, CSA C22.1, as applicable.



### CONTROLLER FUNCTIONS

#### MS-5-RFG MODEL

**Hearth Temperature**  
The floor (hearth) temperature will be displayed when the oven is turned on. Sensor is embedded 1" below the hearth surface. Display will read "LO" when the temperature is below 100 °F.



**Temperature units**

Press and hold to switch between Fahrenheit and Celsius.

**ON/OFF button**

Press to turn oven on and off.

#### MS-5-RFG-IR

**Power indicator light**  
Indicates the oven is turned ON.

**Dome Flame indicator light**  
Indicates the pilot for the radiant flame has lit.

**Hearth Heat indicator light**  
Indicates that the pilot for the infrared underfloor burner is lit. This light will go off whenever the hearth temperature is above the Hearth Set Point.

**Hearth Temperature display**  
Displays temperature of oven floor (hearth). Sensor is embedded 1" below the hearth surface.

**Hearth Set Point display**  
Indicates set point temperature of underfloor IR burner

**On/Off button**  
Press to turn oven on/off

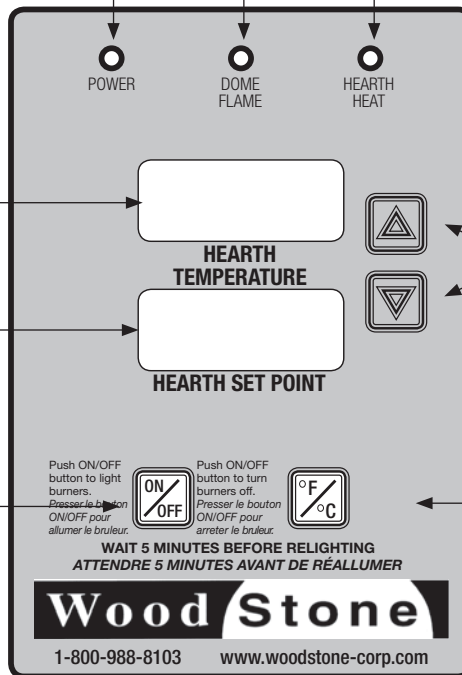

**Arrow buttons**  
Pressing appropriate directional arrow to adjusts Hearth Set Point temperature up or down.

**Temperature unit selector**  
Toggles between Fahrenheit and Celsius temperature scales in display screens



### MS-5 MT ADAMS MODEL INITIAL OVEN START-UP

**NOTE:** The ceramic materials used in the construction of your Wood Stone oven will absorb moisture if exposed to high humidity or damp conditions during shipment from the factory or extended periods of storage before installation. Occasionally, through the course of the initial start-up, as the oven heats up it is possible that you will see some water dripping from the sides of the oven as moisture is driven out of the ceramic. This is not a defect in the oven, and once the oven has been fully saturated with heat, the moisture will be driven fully from the oven. After this initial process, you will not see any additional moisture from the oven unless the oven is not used for an extended period of time AND it is exposed to excessive moisture or high humidity.

**NEVER OPERATE THIS OVEN WITH THE STAINLESS STEEL TRANSPORTATION / NIGHT HEAT RETENTION DOOR IN PLACE. THE DOOR SHOULD ONLY BE USED WHEN THE OVEN IS TURNED OFF!**

#### FIRST DAY

1. Make sure all four propane cylinders are connected. Visually inspect hoses and regulators for any signs of damage.
2. Place chocks or lock the wheels to prevent movement while the oven is in use. Extend flue.
3. There are two banks with two propane cylinders on each bank. Each bank has a changeover valve to select which cylinder on the bank that will be used. Turn the change over valve to point at the cylinder you will be using. Open the valve on that cylinder. Do this for each bank. When the oven is running it will be drawing gas from 2 cylinders simultaneously, which will help minimize condensation and ice build-up on the cylinders. Use the changeover valve to switch cylinders when one runs low or empty.
4. Plug in power supply to the oven. Remove transportation / Night Heat Retention doors from the oven. Make sure the oven flue is in the extended position (twist and lift). Push I/O button on controller

**RFG-IR Model Only:** If Hearth Set Point isn't already set at 100 °F, use the arrows on the controller to set the Hearth Set Point to 100 °F, its lowest setting. Keep the Hearth Set Point at 100 °F throughout this process.

**Note:** This oven utilizes an electronic ignition system and will light automatically. When turning on the oven for the first time, or if the propane cylinders have previously been allowed to run empty, it may take a minute or so for the gas to purge all the air from the gas lines. **If at any time you smell gas in the area of the oven, turn off the oven immediately then turn off the propane supply at the cylinders. Check hoses and connections for leaks. Wait 5 minutes to allow any gas to clear before attempting to restart the oven.**

5. Once the burner ignites, adjust the flame to its lowest setting ("1" on the Flame Height Index) and allow the oven to operate at this setting for about 1 hour.
6. After 4 hours, raise radiant flame to 25% (~5-inch flame).
7. After 4 hours at 25% flame, raise to 50% flame and allow the oven to run until it reaches a temperature of 500 °F. This will take approximately 3-4 hours.
8. The oven is now ready for use.

**NOTE:** Small "crazing" cracks will occur with normal heating and cooling. They will not affect the performance or durability of the oven. If cracks of 1/8" wide or more develop, contact Wood Stone for evaluation.



### END OF THE DAY

Push I/O button on the controller. All gas will go off, including the pilots. When the oven is turned off, use the Night Heat Retention Door to help retain heat in the oven. Place the transportation / Night Heat Retention door(s) placed into the oven doorway. Close tank valves. Retract flue. **WARNING: Flue will be hot after use.**

### DAILY START-UP

1. Remove the transportation / night door(s). Extend the flue. Plug in oven power. Open tank valves.
2. Place chocks or lock the wheels to prevent movement while the oven is in use.
3. Push ON/OFF button. **[For RFG-IR Model Only: Adjust the Hearth Set Point on the control panel to the desired floor temperature.]** Using the Flame Height Control Knob, turn the radiant flame to its highest setting. Check your temperature after approximately one hour. If you are close to your desired temperature, reduce your flame to the holding flame setting that corresponds to your desired temperature. See the FLAME HEIGHT CONTROL section that follows to determine the proper setting that will correspond to your desired temperature.

**Note for RFG-IR Models Only:** It is only possible to program the Hearth Set Point for the underfloor IR burner to temperatures from 100–800 °F. Once proper temperatures for your application have been established, there should be little or no need to change the hearth set point. The hearth temperature readout will display “LO” until the oven floor reaches 100 °F.

**ALWAYS WAIT 5 MINUTES BEFORE RESTARTING THE OVEN.**

**NEVER OPERATE THE OVEN WITH THE TRANSPORTATION / NIGHT HEAT RETENTION DOOR(S) IN PLACE.**

**THIS OVEN IS NOT FOR USE WITH SOLID FUEL**

### OVEN INTERIOR

Wood Stone recommends the use of long-handled brushes for sweeping up surface debris that will accumulate on the floor of the oven during use. Use a natural fiber brush—always brushing away from the radiant burner well. For deeper cleaning, use a brass bristled brush. The oven floor can be then cleaned with a damp rag wrapped around the brass bristled brush head. (Wood Stone offers an assortment of oven brushes available through your dealer. Specification sheets may be viewed on the Wood Stone website under Tools & Accessories.)

### SANITATION

Wood Stone Mountain Series (MS models) ovens carry an ETL sanitation listing. The oven interior only is ETL listed to NSF/ANSI Standard 4. This means that the surfaces of the oven which are meant to be left exposed after the facade has been put in place, have been evaluated from the standpoint of sanitation and food safety and found to comply with NSF/ANSI Standard 4. To operate the oven in accordance with NSF/ANSI Standard 4, only pizza and bread products may be cooked directly on the floor of the oven. Other types of food may be cooked on or in pans, or other suitable containers to prevent spillage onto the oven deck.

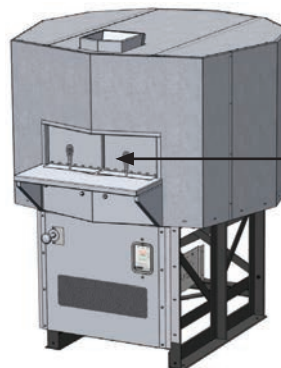

Transportation / Night Heat Retention Doors

**NOTE:** Never operate this appliance with the stainless steel Night Heat Retention Doors in place. The doors should only be used when the oven is turned off. Telescoping flue must be extended while oven is operating.



### CONTROLLER FUNCTIONS

#### BL-4355 BISTRO MODEL

#### Hearth Temperature

The floor (hearth) temperature will be displayed when the oven is turned on. Sensor is embedded 1" below the hearth surface. Display will read "LO" when the temperature is below 100 °F.



#### Temperature units

Press and hold to switch between Fahrenheit and Celsius.

#### ON/OFF button

Press to turn oven on and off.





### BL-4355 INITIAL OVEN START-UP

**NOTE:** The ceramic materials used in the construction of your Wood Stone oven will absorb moisture if exposed to high humidity or damp conditions during shipment from the factory or extended periods of storage before installation. Occasionally, through the course of the initial start-up, as the oven heats up it is possible that you will see some water dripping from the sides of the oven as moisture is driven out of the ceramic. This is not a defect in the oven, and once the oven has been fully saturated with heat, the moisture will be driven fully from the oven. After this initial process, you will not see any additional moisture from the oven unless the oven is not used for an extended period of time AND it is exposed to excessive moisture or high humidity.

**NEVER OPERATE THIS OVEN WITH THE STAINLESS STEEL TRANSPORTATION / NIGHT HEAT RETENTION DOOR IN PLACE. THE DOOR SHOULD ONLY BE USED WHEN THE OVEN IS TURNED OFF!**

#### FIRST DAY

1. Make sure all four propane cylinders are connected. Visually inspect hoses and regulators for any signs of damage.
2. Place chocks or lock the wheels to prevent movement while the oven is in use.
3. There are two banks with two propane cylinders on each bank. Each bank has a changeover valve to select which cylinder on the bank that will be used. Turn the change over valve to point at the cylinder you will be using. Open the valve on that cylinder. Do this for each bank. When the oven is running it will be drawing gas from 2 cylinders simultaneously, which will help minimize condensation and ice build-up on the cylinders. Use the changeover valve to switch cylinders when one runs low or empty.
4. Plug in power supply to the oven. Remove transportation / Night Heat Retention door from the oven. Make sure the oven flue is in the extended position (twist and lift).
5. Push I/O button on controller to turn the oven on.  
**Note:** This oven utilizes an electronic ignition system and will light automatically. When turning on the oven for the first time, or if the propane cylinders have previously been allowed to run empty, it may take a minute or so for the gas to purge all the air from the gas lines. **If at any time you smell gas in the area of the oven, turn off the oven immediately then turn off the propane supply at the cylinders. Check hoses and connections for leaks. Wait 5 minutes to allow any gas to clear before attempting to restart the oven.**
6. Once the burner ignites, make sure the flame is at its lowest setting and allow the appliance to operate at this setting for about 1 hour.
7. After 1 hour, using the Flame Height Control Knob, raise radiant flame to "2" on the Flame Height Index Scale.
8. After 4 hours a raise to "3" on the Flame Height Index Scale and allow the appliance to run until it reaches a temperature of 500 °F. This will take approximately 3–4 hours.
9. The oven is now ready for use.

**NOTE:** Small "crazing" cracks will occur with normal heating and cooling. They will not affect the performance or durability of the oven. If cracks of 1/8" wide or more develop, contact Wood Stone for evaluation.



### END OF THE DAY

Push I/O button on the controller. All gas will go off, including the pilots. When the oven is turned off, use the Night Heat Retention Door to help retain heat in the oven. Place the transportation / Night Heat Retention door(s) into the oven doorway. Close tank valves. Retract flue. **WARNING: Flue will be hot after use.**

### DAILY START-UP

1. Remove the transportation / night door(s). Extend the flue. Plug in oven power. Open tank valves.
2. Place chocks or lock the wheels to prevent movement while the oven is in use.
3. Push I/O button on the controller to to the oven on. Turn the radiant flame to its highest setting using the Flame Height Control Knob. The oven should reach the desired cooking temperature typically within 2 hours. Use the Flame Height Control Knob to control the amount of heat in the oven. See the FLAME HEIGHT CONTROL section that follows to determine the proper setting that will correspond to your desired temperature.

See [woodstone-corp.com](http://woodstone-corp.com) for detailed information on cooking in your Wood Stone oven.

### OVEN INTERIOR

Wood Stone recommends the use of long-handled brushes for sweeping up surface debris that will accumulate on the floor of the oven during use. Use a natural fiber brush—always brushing away from the radiant burner well. For deeper cleaning, use a brass bristled brush. The oven floor can be then cleaned with a damp rag wrapped around the brass bristled brush head. (Wood Stone offers an assortment of oven brushes available through your dealer. Specification sheets may be viewed on the Wood Stone website under Tools & Accessories.

**NEVER PLACE ANYTHING IN OR ABOVE THE RADIANT FLAME**

**ALWAYS WAIT 5 MINUTES BEFORE RESTARTING THE OVEN.**

**THIS OVEN IS NOT FOR USE WITH SOLID FUEL**

### SANITATION

Wood Stone Mountain Series (MS models) ovens carry an ETL sanitation listing. The oven interior only is ETL listed to NSF/ANSI Standard 4. This means that the surfaces of the oven which are meant to be left exposed after the facade has been put in place, have been evaluated from the standpoint of sanitation and food safety and found to comply with NSF/ANSI Standard 4. To operate the oven in accordance with NSF/ANSI Standard 4, only pizza and bread products may be cooked directly on the floor of the oven. Other types of food may be cooked on or in pans, or other suitable containers to prevent spillage onto the oven deck.

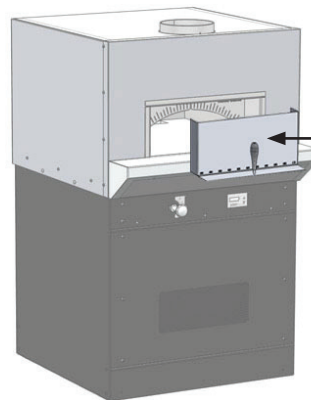

Transportation / Night Heat Retention Doors

**NOTE:** Never operate this appliance with the stainless steel Night Heat Retention Doors in place. The doors should only be used when the oven is turned off. Telescoping flue must be extended while oven is operating.



### DETERMINING THE APPROPRIATE FLAME HEIGHT

For each specific configuration of oven there is a system that determines what the desired flame height will be. Each flame height corresponds to a saturated floor temperature. Several factors need to be accounted for in order to determine this relationship for each oven.

### USING THE FLAME HEIGHT INDICATOR SCALE

**Heat Up Flame:** Set the Flame Height Pointer at "5" (highest setting) on the Flame Height Index Scale until desired temperature is reached.

**Holding Flame:** Using the Flame Height Control Knob, set the flame height to "3" (~8–9" flame) on the Flame Height Index Scale for desired temperature of 570–600 °F. Set the flame height to "2" (~5–6" flame) for desired temperature of 450–480 °F.

**Cooking Flame:** After introducing the pizza/product into the oven, visually raise the flame to approximately 3 inches higher than the Holding Flame.

Return the Flame Height Control Knob to the Holding Flame position after removing the pizza/product from the oven.

### THE COOKING FLAME HAS TWO PURPOSES:

1. To bake the top of the pizza/product as fast as the bottom of the pizza/product.
2. To help replace heat to the floor (hearth) that is lost during production cooking.

**Note:** The settings recommended on the Flame Height Index Scale for specific flames are based on ovens that have been installed according to specifications. Individual results may vary slightly.

### FLAME HEIGHT INDICATOR

Comprised of two parts

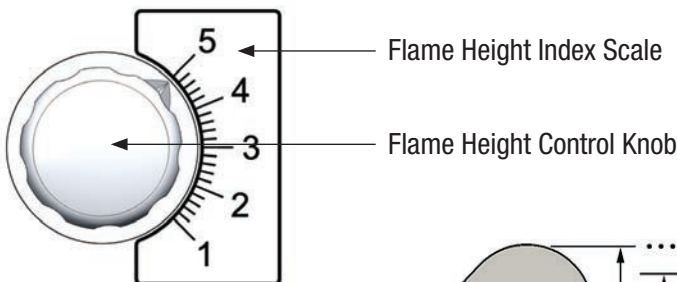

For more information regarding Flame Height Control, go to the Resource Center section of our web site at:  
[www.woodstone-corp.com](http://www.woodstone-corp.com)

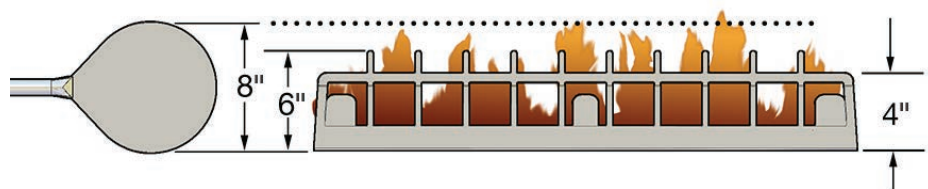



### CLEANING THE OVEN

Clean as needed—multiple times per hour depending on production. Wood Stone recommends the use of long-handled brushes for sweeping up surface debris that will accumulate on the floor of the oven during use. Use a natural fiber brush, always brushing away from the radiant burner well to the doorway where it can be easily removed with a dough cutter or spatula. For deeper cleaning, use a brass bristled brush. The oven floor can be then cleaned with a damp (not wet) rag wrapped around the brush head.

Wood Stone offers an assortment of oven brushes available through your dealer. Specification sheets may be viewed on the Wood Stone website under Tools & Accessories.

### OVEN EXTERIOR

All painted and stainless steel surfaces should be cleaned as necessary using a mild detergent, hot water and a soft cloth or sponge. Stubborn residues may be removed using a nonmetallic scouring pad. When scouring stainless steel surfaces, scrub with the grain of the metal to prevent scratching.

### BL-4355 ONLY: BURNER TRAY

At 6–12 month intervals, depending on the amount of usage, the burner tray beneath the oven should be removed and emptied of any accumulated debris. To remove: unscrew the wing nut at the back of the burner tray. There should be very little debris in the tray if the oven is being operated properly.

**NEVER PLACE ANYTHING IN OR ABOVE THE RADIANT FLAME.**

**NEVER SWEEP DEBRIS INTO THE RADIANT BURNER. THIS CAN CAUSE THE BURNER TO CUT OUT, DAMAGE BURNER COMPONENTS, AND/OR EFFECT BURNER PERFORMANCE. PROBLEMS CAUSED BY DEBRIS IN THE RADIANT BURNER WILL NOT BE COVERED BY THE OVEN WARRANTY.**

**NEVER USE ICE, EXCESSIVE WATER, ANY LIQUID, OR ANY TYPE OF CLEANING CHEMICAL ON THE OVEN FLOOR. DOING SO CAN SEVERELY DAMAGE THE OVEN CERAMIC AND THIS DAMAGE WILL NOT BE COVERED UNDER WARRANTY.**



### ESTABLISHING A THERMAL CLEANING SCHEDULE

Wood Stone ovens are typically operated at temperatures which preclude the need for cleaning of the interior walls and ceiling (the dome) of the oven. If, however, you routinely operate the oven at floor temperatures lower than 450 °F, you may notice a buildup on the interior walls and/or ceiling of the oven. If this is the case, use the following procedure to periodically clean the oven. The frequency of thermal cleaning will be determined by the amount of buildup experienced.

### THERMAL CLEANING

If a Wood Stone gas-fired oven is operated at low temperatures (below 450 °F), it is possible that grease from food could condense on the walls and ceiling of the oven. To remove the grease that has accumulated on the walls and ceiling of the oven, simply turn the radiant flame to its highest setting. Monitor the floor temperature displayed on the controller. When the floor reaches 600 °F, lower the flame slightly so as to maintain the oven floor temperature near 600 °F for about an hour. Once the oven dome appears clean, allow the oven to return to normal operating temperatures and continue normal operation.



PROBLEM	CAUSE/SOLUTION
Controller will not turn on	<ol style="list-style-type: none"> <li>Incoming power to oven turned off. Check circuit breaker for circuit supplying the oven. Check that any wall switches external to the oven that control oven power are turned on. Check that any interlocks external to the oven are turned on.</li> <li>If controller still does not turn on, please contact Wood Stone for assistance.</li> </ol>
Radiant flame does not light	<ol style="list-style-type: none"> <li>Is gas turned on to the oven? Is gas shut-off valve turned all the way on?</li> <li>Debris in burner. Burner may require cleaning. Contact Wood Stone for assistance.</li> <li>Damaged igniter or gas valve. Contact Wood Stone for assistance.</li> </ol> <p>If the oven is being started for the first time:</p> <p>Has all air been bled from the gas line? Is the switch on the SV-2 valve in the ON position?</p> <p><b>NOTE MS-5:</b> Valve is located beneath the oven at the rear, towards the side where the radiant burner is located.</p> <p><b>NOTE BL-4355:</b> Valve is located on the back of the control box, beneath the oven</p>
<b>MS-5-RFG-IR MODEL ONLY</b>	
Controller display reads "Chec"	Underfloor burner did not fire when the floor temperature dropped below the Hearth Set Point. Contact Wood Stone for assistance.
Underfloor burner is not running. "Hearth Heat" light is off.	Hearth temperature is above the Hearth Set Point.
Hearth Temperature is above the Hearth Set Point.	This is normal. Radiant (dome) flame can drive the temperature over the Hearth Set Point. The Hearth Set Point only controls the underfloor (hearth) burner. Turn down the dome flame if needed.
<b>BL-4355 ONLY</b>	
Controller display reads "OPEN"	<ol style="list-style-type: none"> <li>Thermocouple is not plugged into control box.</li> <li>Damaged thermocouple. Contact Wood Stone for assistance.</li> </ol>

Please contact Wood Stone at 1-800-988-8103 should service be necessary, or if you have any questions about your oven. Our service hours are 8am to 4:30pm Pacific Standard Time. Follow the recorded instructions for Emergency Service if you require assistance during non-business hours. A Wood Stone technician will promptly respond to your call.



### BURNER OPERATION SEQUENCE

#### MS-5 RFG OVEN

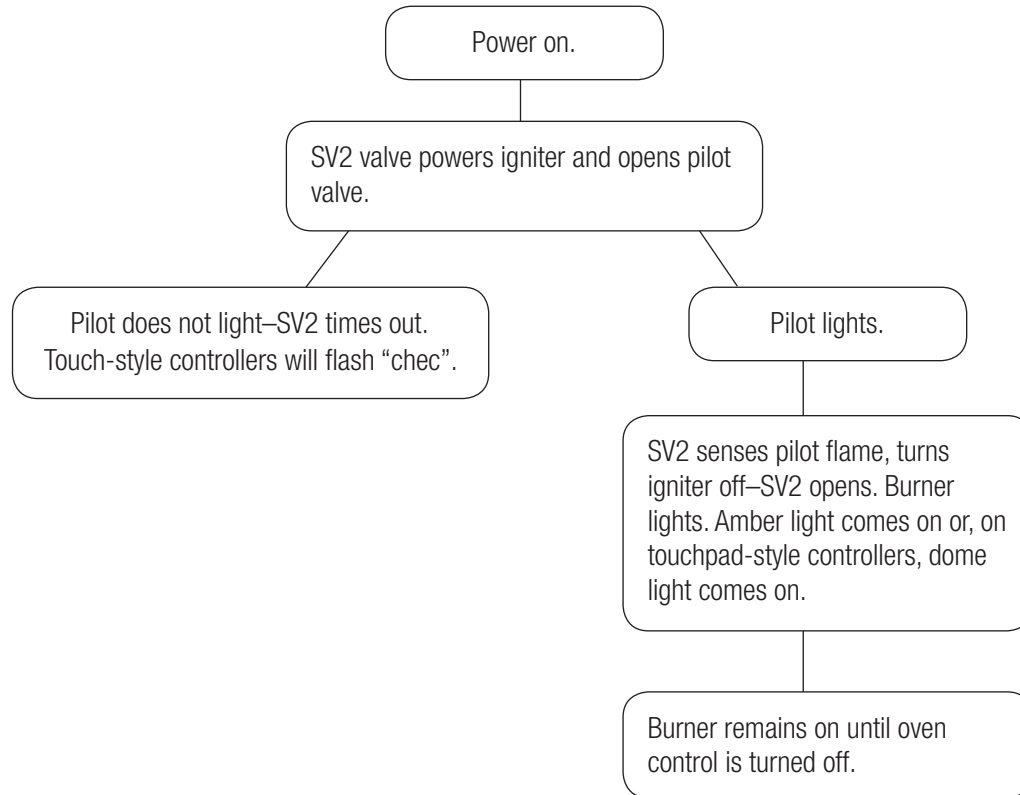

### BURNER OPERATION SEQUENCE MS-5 RFG-IR OVEN - TOUCH PAD CONTROLLERS

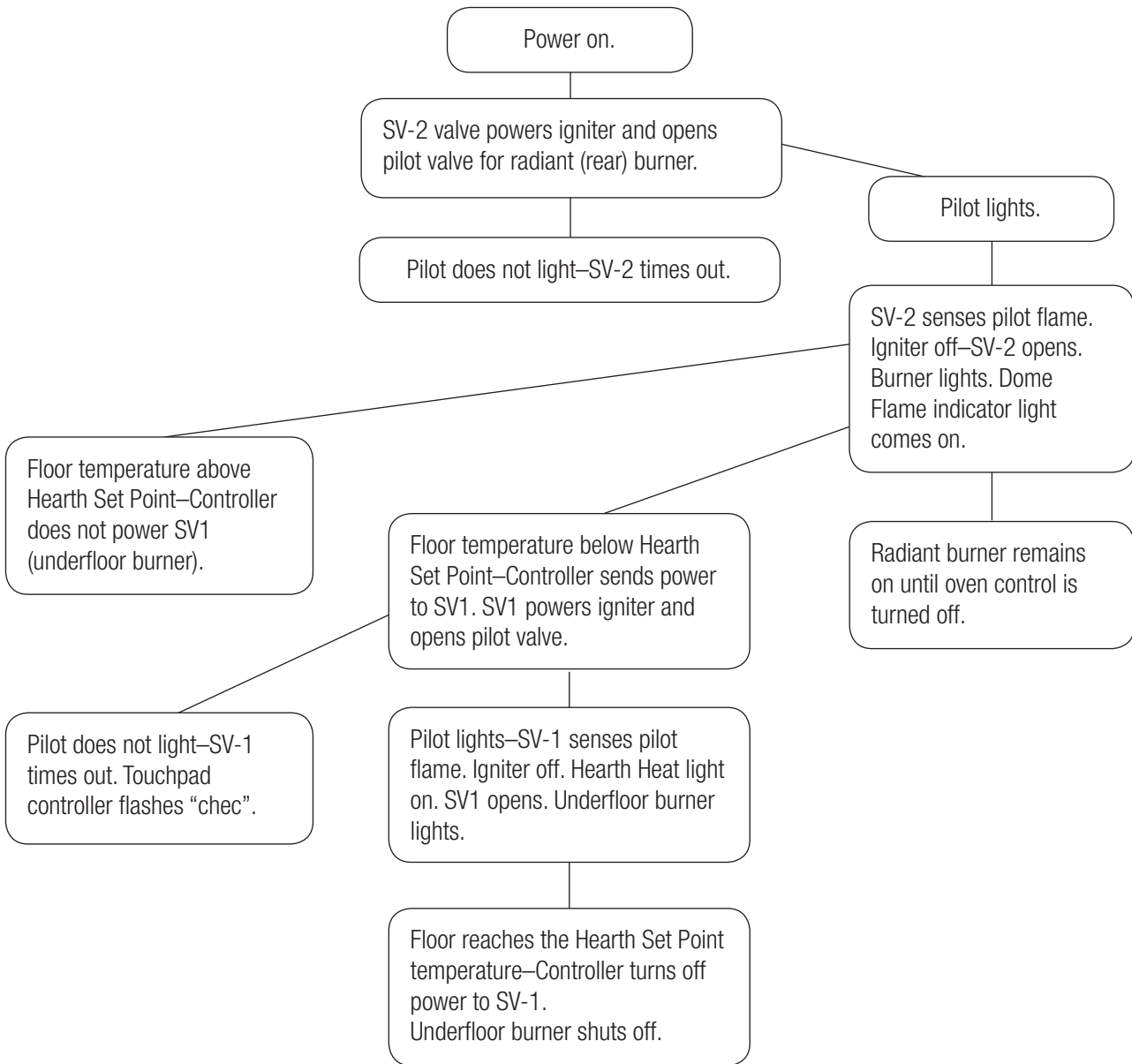





### BURNER OPERATION SEQUENCE RFG OVEN - TOUCH PAD CONTROLLERS

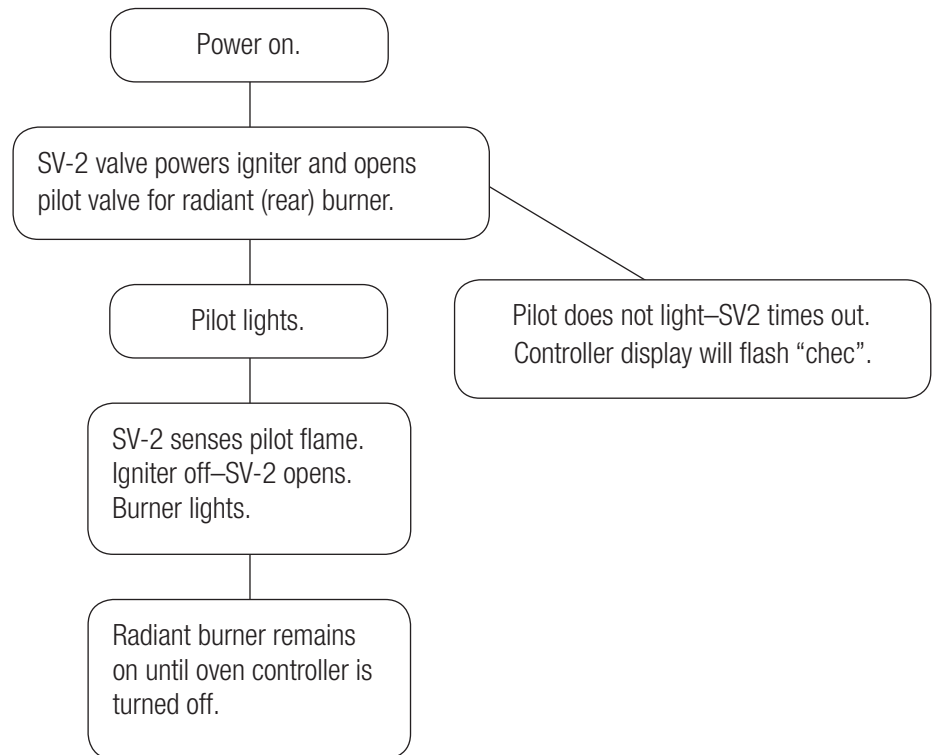



### MS-5 MT ADAMS ELECTRICAL DIAGRAM RFG 120 VAC MODELS WIRE DIAGRAM TYPE 4 CONTROLLER

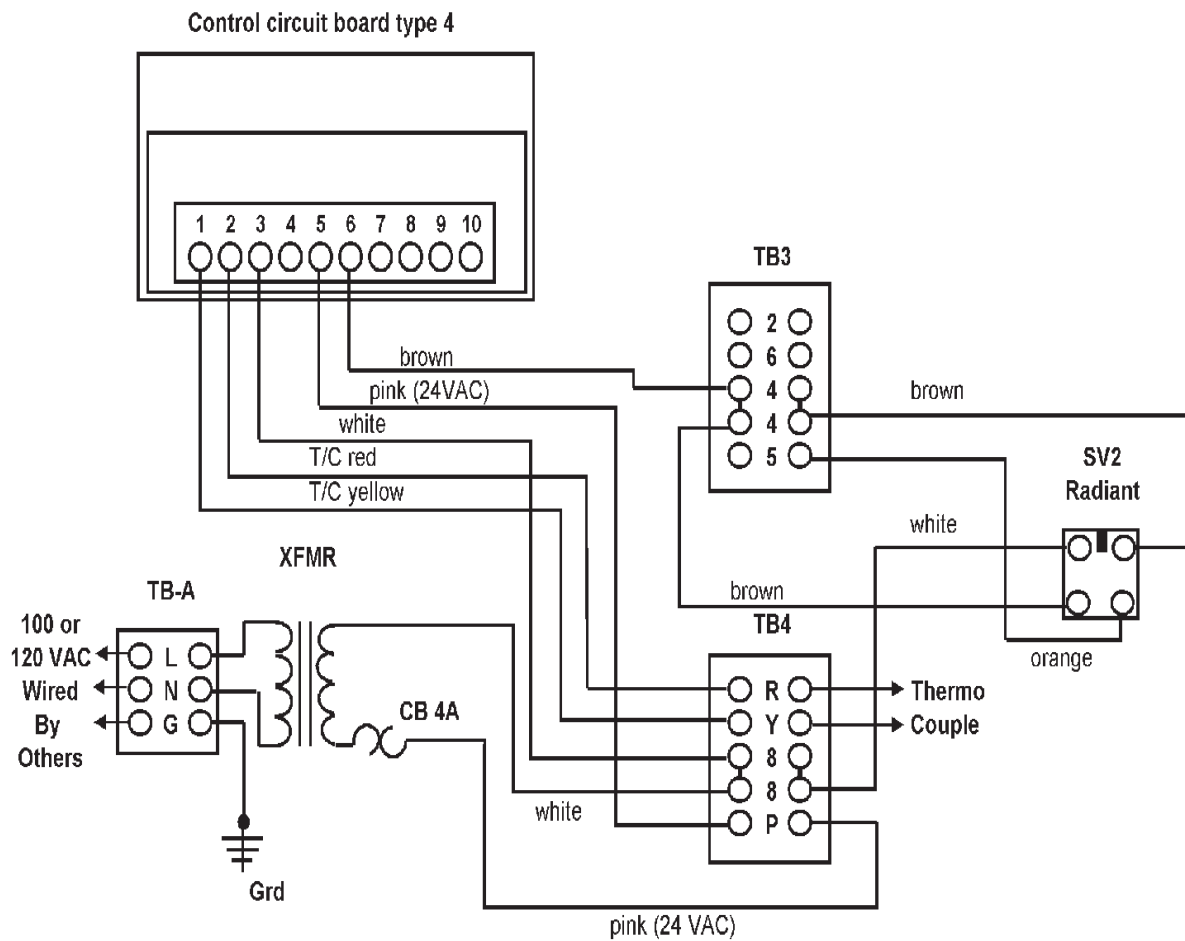

See equipment data plate for correct voltage of your oven.



**MS-5 MT ADAMS ELECTRICAL DIAGRAM  
RFG-IR 120 VAC MODELS WIRE DIAGRAM  
TYPE 2 CONTROLLER**

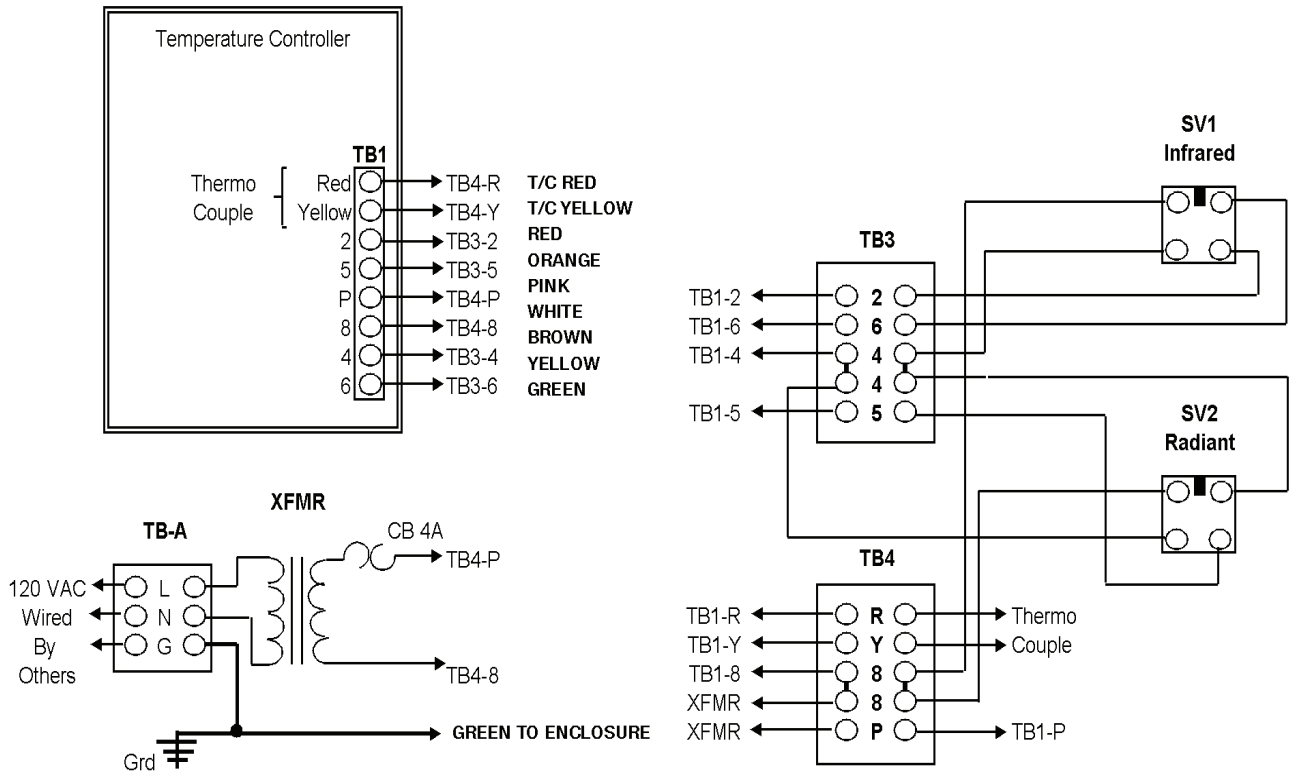

See equipment data plate for correct voltage of your oven.



### BISTRO MODELS WITH HOT SURFACE IGNITION RFG 120 VAC MODELS WIRE DIAGRAM

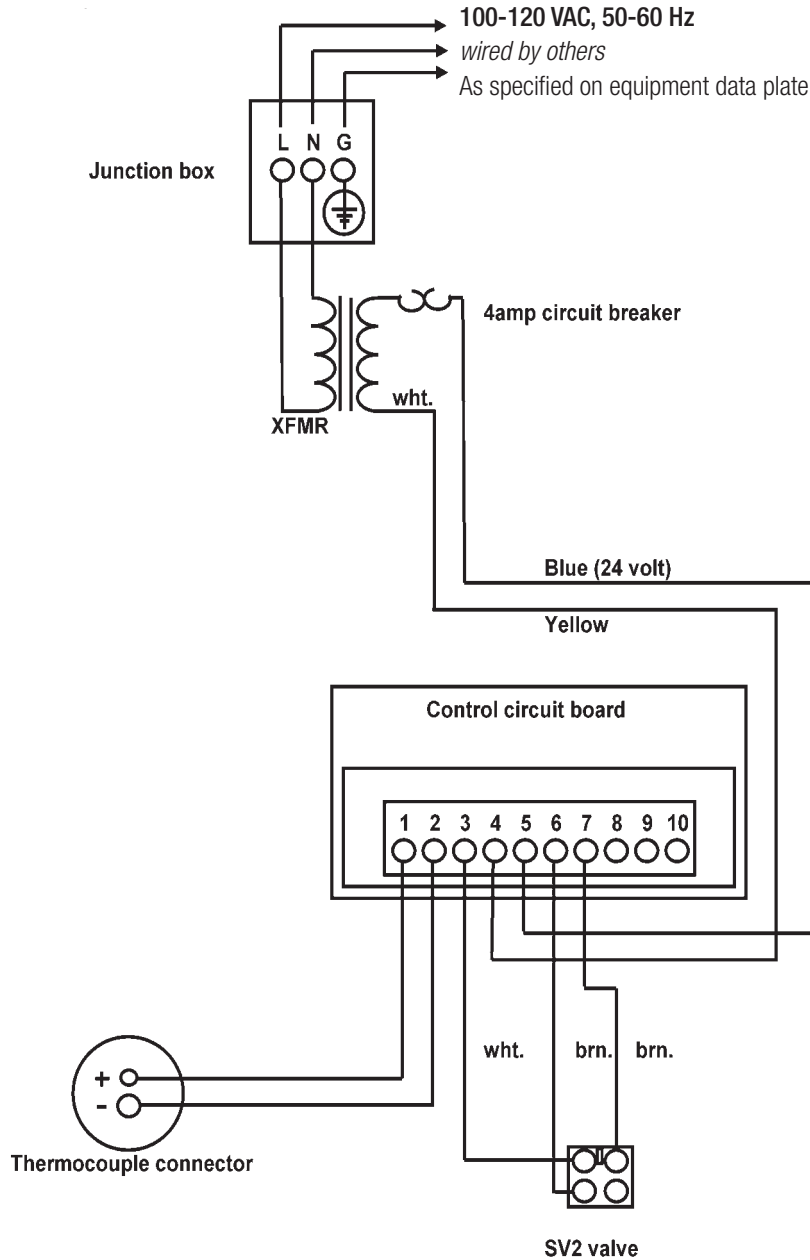

See equipment data plate for correct voltage of your oven.



### ALL WARRANTY SERVICE MUST BE PRE-APPROVED BY WOOD STONE

Wood Stone warrants its equipment to the original purchaser against defects in material or manufacture for a period of one year from the original date of purchase, subject to the following exclusions and limitations.

Please contact the factory first at 1.800.988.8103 or 1.360.650.1111, seven days a week. Our normal business hours are 8am to 4:30pm PST Monday–Friday. If calling during non-business hours, follow the recorded instructions for emergency service and a Wood Stone technician will get back to you promptly.

#### EXCLUSIONS

The warranties provided by Wood Stone do not apply in the following instances:

1. In the event that the equipment is improperly installed. Proper installation is the responsibility of the installer; proper installation procedures are prescribed by the Wood Stone Installation and Operation Manual.
2. In the event the equipment is improperly or inadequately maintained. Proper maintenance is the responsibility of the user; proper maintenance procedures are prescribed in the Wood Stone Installation and Operation Manual. Burner problems resulting from debris or ash in the burner well will not be covered by the warranty. Call with questions regarding maintenance frequency.
3. In the event that the failure or malfunction of the appliance or any part thereof is caused by abnormal or improper use or is otherwise not attributable to defect in material or manufacture.
4. In the event that the appliance, by whatever cause, has been materially altered from the condition in which it left the factory.
5. In the event that the rating plate has been removed, altered or obliterated.
6. On parts that would be normally worn or replaced under normal conditions.
7. Normal cracking due to expansion and contraction stress relief in the ceramic firebox.
8. In wood-fired equipment configurations, in the event that pressed log products of any type have been burned in the equipment.
9. In coal-fired oven configurations, in the event any type of coal other than anthracite coal fuel has been used.
10. Damage resulting from the use of chemical cleaning products in the oven, as well as any damage from liquids or chemicals, including water, being poured or sprayed into the oven.

If any oral statements have been made regarding this appliance, such statements do not constitute warranties and are not part of the contract of sale. This Limited Warranty constitutes the complete, final and exclusive statement with regard to warranties.

**THIS LIMITED WARRANTY IS EXCLUSIVE AND IN LIEU OF ALL OTHER WARRANTIES WHETHER WRITTEN, ORAL OR IMPLIED, INCLUDING, BUT NOT LIMITED TO, ANY WARRANTY OF MERCHANTABILITY OR FITNESS FOR PARTICULAR PURPOSE OR WARRANTY AGAINST LATENT DEFECTS.**

#### LIMITATIONS OF LIABILITY

In the event of warranty claim or otherwise, the sole obligation of Wood Stone shall be the repair and/or replacement, at the option of Wood Stone, of the appliance or component or part thereof. Such repair or replacement shall be at the expense of Wood Stone with the exception of travel over 100 miles or two hours, overtime, and holiday charges which shall be at the expense of the purchaser. Any repair or replacement under this warranty does not constitute an extension of the original warranty for any period of the appliance or for any component or part thereof. Parts to be replaced under this warranty will be repaired or replaced at the option of Wood Stone with new or functionally operative parts. The liability of Wood Stone on any claim of any kind, including claims based on warranty, expressed or implied, contract, negligence, strict liability or any other theories shall be solely and exclusively the repair or replacement of the product as stated herein, and such liability shall not include, and purchaser specifically renounces any rights to recover, special, incidental, consequential or other damages of any kind whatsoever, including, but not limited to, injuries to persons or damage to property, loss of profits or anticipated profits, or loss of use of the product.

#### TO SECURE WARRANTY SERVICE

If you claim a defect covered by this Limited Warranty, contact:

Wood Stone Corporation, Attn: Service Department, 1801 W. Bakerview Rd., Bellingham, WA 98226 USA  
Phone 1.800.988.8103 or 1.360.650.1111