



IP Office D100 SIP Wireless Terminal Installation and Administration Guide

Issue 2.3
December 2012

Notice

While reasonable efforts have been made to ensure that the information in this document is complete and accurate at the time of printing, Avaya assumes no liability for any errors. Avaya reserves the right to make changes and corrections to the information in this document without the obligation to notify any person or organization of such changes.

Documentation disclaimer

"Documentation" means information published by Avaya in varying mediums which may include product information, operating instructions and performance specifications that Avaya generally makes available to users of its products. Documentation does not include marketing materials. Avaya shall not be responsible for any modifications, additions, or deletions to the original published version of documentation unless such modifications, additions, or deletions were performed by Avaya. End User agrees to indemnify and hold harmless Avaya, Avaya's agents, servants and employees against all claims, lawsuits, demands and judgments arising out of, or in connection with, subsequent modifications, additions or deletions to this documentation, to the extent made by End User.

Link disclaimer

Avaya is not responsible for the contents or reliability of any linked websites referenced within this site or documentation provided by Avaya. Avaya is not responsible for the accuracy of any information, statement or content provided on these sites and does not necessarily endorse the products, services, or information described or offered within them. Avaya does not guarantee that these links will work all the time and has no control over the availability of the linked pages.

Warranty

Avaya provides a limited warranty on its hardware and Software ("Product(s)"). Refer to your sales agreement to establish the terms of the limited warranty. In addition, Avaya's standard warranty language, as well as information regarding support for this Product while under warranty is available to Avaya customers and other parties through the Avaya Support website: <http://support.avaya.com>. Please note that if you acquired the Product(s) from an authorized Avaya reseller outside of the United States and Canada, the warranty is provided to you by said Avaya reseller and not by Avaya. "Software" means computer programs in object code, provided by Avaya or an Avaya Channel Partner, whether as stand-alone products or pre-installed on hardware products, and any upgrades, updates, bug fixes, or modified versions thereto.

Licenses

THE SOFTWARE LICENSE TERMS AVAILABLE ON THE AVAYA WEBSITE, [HTTP://SUPPORT.AVAYA.COM/LICENSEINFO/](http://support.avaya.com/licenseinfo/) ARE APPLICABLE TO ANYONE WHO DOWNLOADS, USES AND/OR INSTALLS AVAYA SOFTWARE, PURCHASED FROM AVAYA INC., ANY AVAYA AFFILIATE, OR AN AUTHORIZED AVAYA RESELLER (AS APPLICABLE) UNDER A COMMERCIAL AGREEMENT WITH AVAYA OR AN AUTHORIZED AVAYA RESELLER. UNLESS OTHERWISE AGREED TO BY AVAYA IN WRITING, AVAYA DOES NOT EXTEND THIS LICENSE IF THE SOFTWARE WAS OBTAINED FROM ANYONE OTHER THAN AVAYA, AN AVAYA AFFILIATE OR AN AVAYA AUTHORIZED RESELLER; AVAYA RESERVES THE RIGHT TO TAKE LEGAL ACTION AGAINST YOU AND ANYONE ELSE USING OR SELLING THE SOFTWARE WITHOUT A LICENSE. BY INSTALLING, DOWNLOADING OR USING THE SOFTWARE, OR AUTHORIZING OTHERS TO DO SO, YOU, ON BEHALF OF YOURSELF AND THE ENTITY FOR WHOM YOU ARE INSTALLING, DOWNLOADING OR USING THE SOFTWARE (HEREINAFTER REFERRED TO INTERCHANGEABLY AS "YOU" AND "END USER"), AGREE TO THESE TERMS AND CONDITIONS AND CREATE A BINDING CONTRACT BETWEEN YOU AND AVAYA INC. OR THE APPLICABLE AVAYA AFFILIATE ("AVAYA").

Avaya grants you a license within the scope of the license types described below, with the exception of Heritage Nortel Software, for which the scope of the license is detailed below. Where the order documentation does not expressly identify a license type, the applicable license will be a Designated System License. The applicable number of licenses and units of capacity for which the license is granted will be one (1), unless a different number of licenses or units of capacity is specified in the documentation or other materials available to you. "Designated Processor" means a single stand-alone computing device. "Server" means a Designated Processor that hosts a software application to be accessed by multiple users.

License types

Designated System(s) License (DS). End User may install and use each copy of the Software only on a number of Designated Processors up to the number indicated in the order. Avaya may require the Designated Processor(s) to be identified in the order by type, serial number, feature key, location or other specific designation, or to be provided by End User to Avaya through electronic means established by Avaya specifically for this purpose.

Concurrent User License (CU). End User may install and use the Software on multiple Designated Processors or one or more servers, so long as only the licensed number of Units are accessing and using the Software at any given time. A "Unit" means the unit on which Avaya, at its sole discretion, bases the pricing of its licenses and can be, without limitation, an agent, port or user, an e-mail or voice mail account in the name of a person or corporate function (e.g., webmaster or helpdesk), or a directory entry in the administrative database utilized by the Software that permits one user to interface with the Software. Units may be linked to a specific, identified Server.

Database License (DL). End User may install and use each copy of the Software on one Server or on multiple Servers provided that each of the Servers on which the Software is installed communicates with no more than a single instance of the same database.

CPU License (CP). End User may install and use each copy of the Software on a number of Servers up to the number indicated in the order provided that the performance capacity of the Server(s) does not exceed the performance capacity specified for the Software. End User may not re-install or operate the Software on Server(s) with a larger performance capacity without Avaya's prior consent and payment of an upgrade fee.

Named User License (NU). You may: (i) install and use the Software on a single Designated Processor or Server per authorized Named User (defined below); or (ii) install and use the Software on a Server so long as only authorized Named Users access and use the Software. "Named User", means a user or device that has been expressly authorized by Avaya to access and use the Software. At Avaya's sole discretion, a "Named User" may be, without limitation, designated by name, corporate function (e.g., webmaster or helpdesk), an e-mail or voice mail account in the name of a person or corporate function, or a directory entry in the administrative database utilized by the Software that permits one user to interface with the Software.

Shrinkwrap License (SR). You may install and use the Software in accordance with the terms and conditions of the applicable license agreements, such as "shrinkwrap" or "clickthrough" license accompanying or applicable to the Software ("Shrinkwrap License").

Heritage Nortel Software

"Heritage Nortel Software" means the software that was acquired by Avaya as part of its purchase of the Nortel Enterprise Solutions Business in December 2009. The Heritage Nortel Software currently available for license from Avaya is the software contained within the list of Heritage Nortel Products located at <http://support.avaya.com/LicenseInfo> under the link "Heritage Nortel Products". For Heritage Nortel Software, Avaya grants Customer a license to use Heritage Nortel Software provided hereunder solely to the extent of the authorized activation or authorized usage level, solely for the purpose specified in the Documentation, and solely as embedded in, for execution on, or (in the event the applicable Documentation permits

installation on non-Avaya equipment) for communication with Avaya equipment. Charges for Heritage Nortel Software may be based on extent of activation or use authorized as specified in an order or invoice.

Copyright

Except where expressly stated otherwise, no use should be made of materials on this site, the Documentation, Software, or hardware provided by Avaya. All content on this site, the documentation and the Product provided by Avaya including the selection, arrangement and design of the content is owned either by Avaya or its licensors and is protected by copyright and other intellectual property laws including the sui generis rights relating to the protection of databases. You may not modify, copy, reproduce, republish, upload, post, transmit or distribute in any way any content, in whole or in part, including any code and software unless expressly authorized by Avaya. Unauthorized reproduction, transmission, dissemination, storage, and or use without the express written consent of Avaya can be a criminal, as well as a civil offense under the applicable law.

Third Party Components

“Third Party Components” mean certain software programs or portions thereof included in the Software that may contain software (including open source software) distributed under third party agreements (“Third Party Components”), which contain terms regarding the rights to use certain portions of the Software (“Third Party Terms”). Information regarding distributed Linux OS source code (for those Products that have distributed Linux OS source code) and identifying the copyright holders of the Third Party Components and the Third Party Terms that apply is available in the Documentation or on Avaya’s website at: <http://support.avaya.com/Copyright>. You agree to the Third Party Terms for any such Third Party Components.

Preventing Toll Fraud

“Toll Fraud” is the unauthorized use of your telecommunications system by an unauthorized party (for example, a person who is not a corporate employee, agent, subcontractor, or is not working on your company’s behalf). Be aware that there can be a risk of Toll Fraud associated with your system and that, if Toll Fraud occurs, it can result in substantial additional charges for your telecommunications services.

Avaya Toll Fraud Intervention

If you suspect that you are being victimized by Toll Fraud and you need technical assistance or support, call Technical Service Center Toll Fraud Intervention Hotline at +1-800-643-2353 for the United States and Canada. For additional support telephone numbers, see the Avaya Support website: <http://support.avaya.com>. Suspected security vulnerabilities with Avaya products should be reported to Avaya by sending mail to: securityalerts@avaya.com.

Trademarks

The trademarks, logos and service marks (“Marks”) displayed in this site, the Documentation and Product(s) provided by Avaya are the registered or unregistered Marks of Avaya, its affiliates, or other third parties. Users are not permitted to use such Marks without prior written consent from Avaya or such third party which may own the Mark. Nothing contained in this site, the Documentation and Product(s) should be construed as granting, by implication, estoppel, or otherwise, any license or right in and to the Marks without the express written permission of Avaya or the applicable third party.

Avaya is a registered trademark of Avaya Inc.

All non-Avaya trademarks are the property of their respective owners, and “Linux” is a registered trademark of Linus Torvalds.

Downloading Documentation

For the most current versions of Documentation, see the Avaya Support website: <http://support.avaya.com>.

Contact Avaya Support

See the Avaya Support website: <http://support.avaya.com> for product notices and articles, or to report a problem with your Avaya product. For a list of support telephone numbers and contact addresses, go to the Avaya Support website: <http://support.avaya.com>, scroll to the bottom of the page, and select Contact Avaya Support.

Contents

Chapter 1: Overview	7
Phone functionality.....	8
Capacity and performance.....	9
Chapter 2: Hardware and display elements	11
Base station.....	11
Handset.....	12
Repeater.....	13
Charge unit.....	14
Headset.....	14
Upgrade Jig.....	15
Display properties.....	15
Chapter 3: System configuration	19
IP Office deployment scenarios.....	19
Configuring the D100 using IP Office Manager.....	21
Configuring the base station.....	22
Configuring the extensions.....	23
Configuring the static IP parameters for the base station.....	25
Configuring the D100 using the Base Station Web Management Interface.....	26
Chapter 4: Hardware preparation and installation	29
Overview.....	29
Site planning.....	30
Base station installation.....	36
Handset registration.....	43
Signal strength survey.....	46
Repeater installation.....	47
Chapter 5: Coverage information	53
Out of range.....	53
Chapter 6: Administration and maintenance	55
Overview.....	55
System Status Application.....	56
Administration on the handset.....	59
Base Station Web Management Interface.....	71
Updating base station firmware.....	75
Updating handset firmware.....	76
Chapter 7: Factory settings	79
Resetting the base station to factory default.....	80
Resetting the base station using System Status Application.....	80
Resetting the base station using the Base Station Web Management Interface.....	81
Resetting the base station using the base station.....	81
Chapter 8: Accessories	83
Chapter 9: Troubleshooting	85
Changed IP parameters and lost connectivity to the base station.....	85
Configuring parameters using the Base Station Web Management Interface.....	85
Handset display reads "Duplicate IP Address".....	86

Handset display reads “No Service”.....	86
Handset display reads “Searching”.....	86
Handset not recognized by the upgrade firmware.....	87
Maintenance Mode.....	87
Repeater registration failure.....	88
Unknown DECT PIN.....	88
Unknown IP address.....	88
Index.....	89

Chapter 1: Overview

The D100 SIP Wireless Terminal is a cordless phone system that is adapted for IP Office. The D100 solution delivers the productivity-boosting benefits of IP and wireless communications across multiple offices in a convenient, lightweight handset. The D100 is a highly functional wireless solution with scalability to support large numbers of users. A single base station can support up to eight handsets, with each handset supporting five calls. Each IP Office can support up to four base stations.

The D100 base station and D160 handset extensions are configured using IP Office Manager. While some administrative options are available using the handset, the preferred method of configuration is through IP Office Manager. Use System Status Application to administer the D100 and view configuration details.

The critical factor for installation is the location of the base station, which emits the wireless signal range up to 350 feet (100 metres) indoors. You can extend this range using repeaters.



Before you begin, ensure that you have the required hardware and the latest firmware. Also ensure that your users have an applicable license.

Licensing

Each D160 handset user requires an Avaya IP Endpoint license. Any additional license, such as a Power or Mobile user license, determines the additional features available to that user. The user consumes the

license while they are logged in and they stop consuming the license when they log out. The user does not require licensing specific to the base station.

Other factors

In ideal open field conditions, the range between a phone and a standard base station can be up to 700 feet (200 meters). However, in indoor conditions with obstacles absorbing signal strength and reflected signals giving increased error rates, the range is more realistically between 100 to 350 feet (30 to 100 meters).

In practice, no rules or guarantees can be given for base station coverage. Too many factors that are unique to each site can affect coverage. For more information, see [Base station installation scenarios](#) on page 37. See also [Site planning](#) on page 30.

Phone functionality

The following table summarizes the phone functions available on the D100.

Category	Support
Telephony	<ul style="list-style-type: none"> • Account Code Entry • Automatic Callback • Automatic Intercom - Dial voice call • After Call Work • Button Programming • Call Forward • Call Log • Call Pickup Any • Call Park • Call Record • Conference • Conference Meet Me • Directed Call Pickup • Do Not Disturb • Emergency call • Extension Login/Logout • Follow Me Here/To • Forward All • Group Page • Group Pickup • Hot Desking • Make and drop call • Mute • Private Call • Relay On/Pulse • Redial • Remote Park • Retrieve Call • Speed Dial • Stamp Log • Transfer • Twinning • Voicemail

Category	Support
Language	<ul style="list-style-type: none"> • English • French • Italian • German • Spanish
Ethernet	10/100 Mbps, half/full duplex, auto-negotiation
Network	TCP, UDP, IP, DHCP, HTTP (future support planned for VLAN, 802.1x and SNMP).
DoS Attack Protection	<ul style="list-style-type: none"> • LAND attack • Ping Of Death • SYN flooding attack • ARP attack
Codec	G.711
Handset	You can connect up to eight handsets to a single base station.

Capacity and performance

Capacity and performance specifications for the D100 appear below.

Base station capacity and performance

Item	Value
Cell radius	100 to 350 feet (30 to 100 metres) indoors
Maximum number of base stations per IP Office	4 base stations
Maximum number of handsets that can belong to a base station	8 handsets
Maximum simultaneous calls per base station	40 calls (5 calls per handset)
Maximum number of repeaters per base station	6
Maximum number of entries for global directory	100
Maximum number of entries for local directory	100 entries per handset

Item	Value
Maximum number of call logs	100 logs per handset (for both incoming and outgoing calls)

Handset capacity and performance

Item	Value
Maximum simultaneous calls per handset	5 calls
Average talk time (with new battery)	16 hours
Average standby time (with new battery)	168 hours

Repeater capacity and performance

Item	Value
Cell radius	100 to 350 feet (30 to 100 metres) indoors
Maximum number of repeaters per base station	6
Maximum number of linked repeaters	3
Maximum number of channels per repeater	4 Note that calls carried from linked repeater consumes channels.

Limitations

- There is currently no support for DTMF over SIP Info.
- There is currently no support for Account Code Entry using a soft key.

Chapter 2: Hardware and display elements

Base station



No.	Label	Description
1	Reset button hole	Press and hold for five seconds to reset the base station.
2	Registration button	Press and hold until the base station LED flashes to register the base station with IP Office. Hold this button for three seconds when registering handsets.

For more information, see the following:

- [Capacity and performance](#) on page 9
- [Base station installation](#) on page 36

- [Performing a base station survey](#) on page 35
- [Signal strength survey](#) on page 46
- [Reset base station](#) on page 63
- [Updating base station firmware](#) on page 75
- [Handset registration](#) on page 43

Handset



No.	Label	Description
1	Up/Down keys	Use the Up/Down keys to control the speaker and ringer volume. You can also use these keys to correct name and number entry when programming a speed dial button.
2	Mute key	Use the Mute key to mute the handset microphone.
3	Soft keys (S1–S4)	Use a soft key to activate the option listed directly above the key on the display. The D160 has four soft keys.

No.	Label	Description
4	Off-Hook/Handsfree key	Use the Off-Hook/Handsfree key to answer a call or to enter the handsfree mode.
5	On-Hook key	Use the On-Hook key to end a call or to exit a menu.
6	Dialpad	Use the Dialpad to make calls, to enter contact phone numbers and names, and to navigate through contacts and call logs.
7	Function keys (F1–F8)	Use a function key to activate the feature assigned to that function key. The D160 has eight configurable function keys.

For more information, see the following:

- [Capacity and performance](#) on page 9
- [Powering the handset](#) on page 43
- [Handset registration](#) on page 43
- [Updating handset firmware](#) on page 76

Repeater

Repeaters effectively extend the range of the base station by 100 to 350 feet (30 to 100 metres) indoors.



For more information, see the following:

- [Capacity and performance](#) on page 9
- [Repeater installation](#) on page 47

- [Repeater registration](#) on page 48
- [Signal strength survey](#) on page 46

Charge unit

The following image shows the charge unit from three different angles. Note that you can leave the handset in the charge unit when it is not in use.



No.	Label	Description
1	Rechargeable battery slot	To recharge a spare D100 battery.
2	Cradle	To hold the handset upright while it charges.
3	Blue handset LED	To indicate when the handset is placed in the charge unit.
4	Blue battery LED	To indicate when the battery slot is in use.
5	Battery slot tab	To lock the rechargeable battery in place. Press down on this tab to unlock and remove the battery.

Headset

To use a headset, plug the headset into the headset jack during the talk or handsfree modes. While using a headset, you can switch between the talk mode and the handsfree mode, but the headset mode remains active until you unplug the headset.

Upgrade Jig

You require the Upgrade Jig to update the handset firmware.



For more information, see [Updating handset firmware](#) on page 76.

Display properties







The following sections describe the display properties for the handset LCD as well as the base station, charger, and repeater LEDs.

Handset LCD



The handset LCD consists of three rows. The top row consists of six icons while the remaining two rows consist of 24 alphanumeric characters.

The following tables describe the icons and soft key options visible on the handset LCD.

Status icon	Description
	The handset talk mode icon. This icon is on during an active call and flashes when a call is on hold.
	<p>The battery status icon. The number of bars visible on the icon indicates the power level of the battery. When the handset is on the charger, the battery status icon cycles through each icon level from Low to Full until the phone is fully charged.</p> <ul style="list-style-type: none"> • Battery Full = Three bars indicate that the remaining capacity is between 70 and 100%. • Battery Level 2 = Two bars indicate that the remaining capacity is between 40 and 70%. • Battery Level 1 = One bar indicates that the remaining capacity is between 15 and 40%. • Battery Low = Zero bars indicate that the remaining capacity is between 5 and 15%. The icon flashes intermittently. • “Change Battery” Message = The phone is not functional. The remaining capacity is between 0 and 5%.
	The mute icon. Indicates that the ringer is set to Off . In the Vibrate mode, the mute icon is not visible.
	The mail icon. Indicates a new voicemail message.
	The speaker icon. Indicates that the phone is in the handsfree mode.
	The mute icon. Indicates that the microphone is muted.

Soft key	Description
Featur	To access the Feature mode.
Msgs	To access the Voicemail feature.
Redial	To call the most recently called number.
More..	To access more soft key item lists (see below).
CLog	To access the Call Log page.

Soft key	Description
Dir	To display the system and local phone directories.
Time	To display the current time, accessed using the More.. soft key.
Config	To access the configuration menus, such as “User Settings”. See Configuration overview for more information. Use the More.. soft key to access the Config option.
123	To switch to numeric input mode, accessed using the More.. soft key.
abc	To switch to alphabetic input mode (the default), accessed using the More.. soft key.

Base station LED

The base station has two LEDs. The green LED indicates the connection status, and the blue LED indicates the base station operating mode.

Green LED state	Connection status
On	Connected to IP Office
Off	Not connected to IP Office
Flashing	Trying to connect to IP Office

Blue LED state	Base station mode
On	The normal operating mode
Off	The base station is powered off
Flashing (300ms on, 300ms off)	The registration mode
Flashing (200ms on, 200ms off)	The maintenance mode
Flashing (300ms on, 100ms off)	The maintenance mode, or the default IP setting mode

Repeater LED

LED state	Repeater status
On	Connected to the base station
Off	Not powered or registered to a base station
Flashing	The searching mode, or attempting to connect to the base station

Chapter 3: System configuration

The following sections contain all the information needed to configure IP Office for the D100 SIP wireless terminal using IP Office Manager. Read the following instructions to determine scenarios, configure IP Office, and create extensions and users. For information on powering and booting up the device, discovering IP Office, registering DECT RF, and installing repeaters, see [Hardware preparation and installation](#) on page 29.

Limitations:

The D100 base station can handle a maximum of 40 characters in the SIP URI.

In IP Office Manager, navigate to **System > LAN1 > SIP Registrar** and ensure that the parameter entered in the **Domain Name** field is an appropriate length according to the 40 character SIP URI limitation.

IP Office deployment scenarios

When preparing IP Office for D100 deployment, you must configure the correct type of network addressing. The location of the DHCP server and the number of IP Office servers in the subnet determine the network addressing scenario.

By default, the base station is configured as a DHCP client and IP Office is the preferred DHCP server. In this scenario, the system requires minimum configuration. The base station obtains the IP address, subnet mask, default gateway, and configuration server address from the DHCP server.

If the network uses a third-party DHCP server, the base station obtains the IP address, subnet mask, and default gateway from the DHCP server and then runs an IP Office discovery mechanism to obtain the configuration server address. The base station then registers to the first IP Office that responds. In this situation, only one IP Office server can be available on the subnet. Refer to Scenario 1.

If multiple IP Office servers are available on the subnet, the IP Office discovery mechanism will not work properly. You must use static addressing where multiple IP Office servers exist on the same subnet. Refer to Scenario 2.

When adding a new SIP DECT Line, IP Office Manager assumes that the base station acts as the DHCP client. In some deployments, configuring the base station's IP parameters statically might be desirable.

A single IP Office can support up to four base stations. If multiple base stations are connected to an IP Office, you must configure the **MAC Address** parameter for each of the SIP DECT

Lines using IP Office Manager. If only one base station is connected to the IP Office, you do not need to configure the **MAC Address**.

Consider the following network configuration scenarios before you deploy the D100 terminal.

Network configuration	Scenario reference
A single IP Office in the subnet that hosts the DHCP server.	Follow Scenario 1
A single IP Office in the subnet with DHCP hosted by a third-party server.	Follow Scenario 1
Multiple IP Office units with the DHCP located on an IP Office unit where the base station is configured.	Follow Scenario 1
All other network configuration scenarios require static IP addressing.	Follow Scenario 2

Scenario 1

You must configure the base station in IP Office Manager.

In this scenario, you can still configure the base station with static IP parameters. If you configure static IP parameters, the base station uses and maintains these parameters after rebooting the base station, or until you modify the IP parameters in IP Office Manager.

Procedure

1. Configure the base station in IP Office Manager:
 - Configure the SIP DECT Line as described in [Configuring the base station](#) on page 22.
 - Configure the SIP DECT Extensions as described in [Configuring the extensions](#) on page 23.
 - **Optional:** Configure the static IP parameters for the base station. See [Configuring the static IP parameters for the base station](#) on page 25.

Double-check the values you enter as you might inadvertently lose connectivity to the base station by providing incorrect values.

2. Connect the base station to the subnet where the IP Office can be reached.

The base station downloads the configuration parameters and reboots if any parameters were modified.

Scenario 2

You must use static IP addressing for the base station.

In static addressing, you must configure each base station individually in IP Office Manager with network-specific addressing. In addition, you must configure static IP addressing on the base station prior to installing it on the network.

Since static addressing requires DHCP to be off, the base station cannot retrieve the network parameters from IP Office and you must turn off the DHCP client and configure the base station's network parameters using the Base Station Web Management Interface.

A base station is configured as a DHCP client by default, so you must access that base station and configure the addressing parameters, otherwise the base station assigns an address automatically. When there is no DHCP server in the subnet, the base station uses the following addressing parameters:

- **IP Address:** 192.168.1.100
- **Mask:** 255.255.0.0

Once you know the IP address of the base station, enter this address in a web browser on a PC connected to the subnet. Doing so provides access to the Base Station Web Management Interface. For more information, see [Base Station Web Management Interface](#) on page 71 .

Procedure

1. Configure the base station in IP Office Manager according to the instructions in [Configuring the D100 using IP Office Manager](#) on page 21.
 - Configure the SIP DECT Line as described in [Configuring the base station](#) on page 22.
 - Configure the SIP DECT Extensions as described in [Configuring the extensions](#) on page 23.
 - **Mandatory:** Configure the static IP parameters for the base station. See [Configuring the static IP parameters for the base station](#) on page 25.
2. In the Base Station Web Management Interface, configure the static IP parameters for the base station. See [Configuring the D100 using the Base Station Web Management Interface](#) on page 26.
3. Connect the base station to the subnet where the IP Office resides.

The base station downloads the configuration parameters and reboots if any parameters were modified.

Configuring the D100 using IP Office Manager

Using IP Office Manager, configure the D100 for use on IP Office.

You must configure the D100 components in IP Office prior to connecting and powering the base station. Otherwise, if the base station is already connected and running, you will have to reboot the base station after you configure IP Office.

The D100 SIP DECT system consists of two types of components:

- A **SIP DECT Line** that represents a D100 base station
- A **SIP DECT Extension** that links a specific user to a D100 base station

Ensure that you associate a SIP DECT Extension with a single SIP DECT Line.

Before you begin

Install IP Office Manager and connect it to a fully functioning IP Office. Obtain an Avaya IP Endpoint license for each D160 handset. The user consumes the license while they are logged in and they stop consuming the license when they log out.

Obtain any licenses, such as Power user or Mobile user licenses, that provide the user with additional features.

The user does not require licensing specific to the base station.

Related topics:

[Configuring the base station](#) on page 22

[Configuring the extensions](#) on page 23

[Configuring the static IP parameters for the base station](#) on page 25

Configuring the base station

Procedure

1. In IP Office Manager, open the **Line** menu for the desired IP Office control unit.
2. Right-click any line and select **New > SIP DECT Line**.

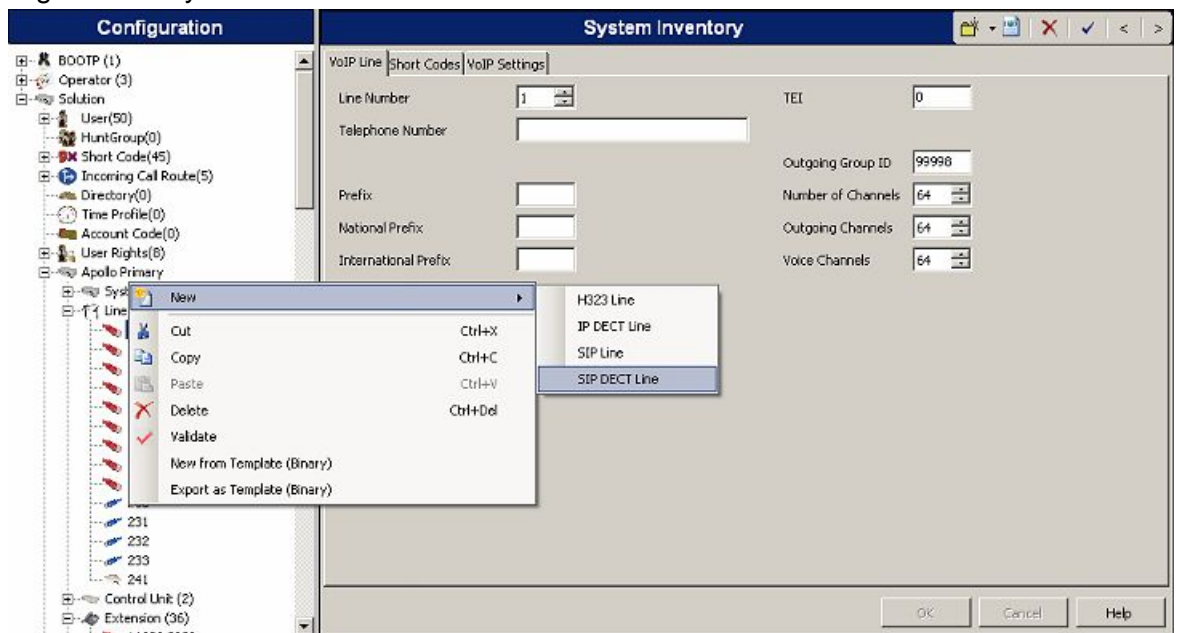

3. Configure **Base Name** and **Base MAC Address**. You do not need to configure the MAC address if only one base station is configured.

Base Name	D100
Base MAC Address	00 e0 11 0b 08 50

- Click the **VoIP** tab and configure the VoIP parameters. You can modify the default values if necessary.
Note that the D100 supports only G.711 codecs.

- Press **OK**.

Next steps

Configure at least one extension to associate with the SIP DECT line. See [Configuring the extensions](#) on page 23.

Configuring the extensions

Procedure

- In IP Office Manager, open the **Extension** menu for the desired IP Office control unit.

- Right-click any extension and select **New > SIP DECT Extension**.

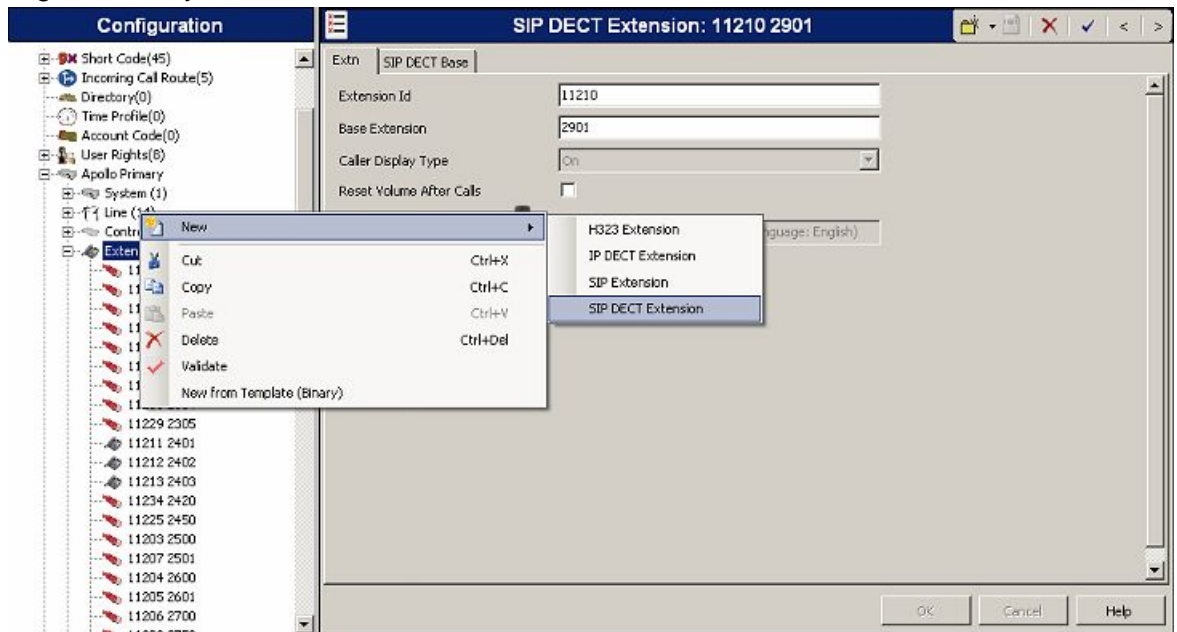

- Configure the extension parameters.
- Navigate to the **SIP DECT Base** tab and select the base station to which this extension belongs.

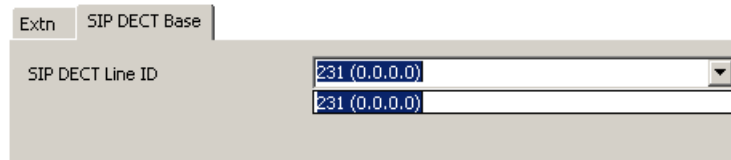

- Press **OK**.
- Confirm the creation of an associated user. Select **Yes** to accept or **No** to cancel. If you select **Yes**, the system opens the user configuration window.
- Configure the user as you would for a regular SIP extension.
- Navigate to the **Telephony > Supervisor Settings** tab and configure the **Login code** for the user.

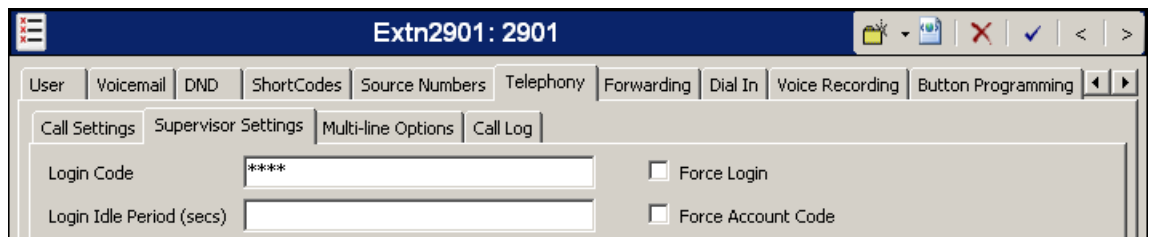

- Press **OK**.

Next steps

If necessary, configure additional extensions and users.

Configuring the static IP parameters for the base station

If the base station IP address is statically assigned, you must configure IP Office with the address of the base station.

Procedure

1. In IP Office Manager, open the **Line** menu for the desired IP Office control unit and select the SIP DECT line dedicated to the base station.
2. In the **SIP DECT Line** window, enable the **Configure Base IP** settings and uncheck the **DHCP Client** checkbox.

The screenshot shows a configuration window with a title bar that includes a checked checkbox for 'Configure Base IP'. Below this, there is a label 'DHCP Client' followed by an unchecked checkbox.

3. Configure the parameters for **IP Address**, **IP Mask**, **IP Gateway**, and **Provisioning Server**.

The screenshot shows the same configuration window as above, but with additional fields filled in. The 'DHCP Client' checkbox remains unchecked. The 'IP Address' field contains '47 . 135 . 152 . 8', the 'IP Mask' field contains '255 . 255 . 255 . 0', the 'IP Gateway' field contains '47 . 135 . 152 . 1', and the 'Provisioning Server' dropdown menu is set to '47.135.151.150'.

4. Select the appropriate server from the **Provisioning Server** drop down menu.

The screenshot shows a close-up of the 'Provisioning Server' dropdown menu. The current selection is '47.135.151.150'. The dropdown list is open, showing three options: '47.135.151.150' (highlighted in blue), '47.135.151.150', and '192.168.43.1'.

Configuring the D100 using the Base Station Web Management Interface

In an IP Office deployment scenario that requires static addressing, you must configure the static IP parameters of the base station using the Base Station Web Management Interface so that the base station can connect to IP Office and download the necessary configurations.

For information on accessing the interface, see [Base Station Web Management Interface](#) on page 71.

Procedure

1. Log into the Base Station Web Management Interface and select **Configuration Parameters** from the side menu. The Configuration Parameters window lists the base station details, as shown in the following image:

Setting Menu	
Configuration Parameters	
Retrieve Logs	
Reboot Base Station	
Update Firmware of Base Station	
Soft Reset	
DECT Menu	
DECT Registration	
DECT De-Registration	

Configuration Parameters

General information of the Base Station

Firmware Version D100_0.8.3_0.8.3

Hardware Version 4

Network configuration Information

DHCP Setting on off

MAC Address 00-e0-11-0b-08-fa

IP Address

Subnet Mask

Default Gateway

Configuration Server

2. Configure the parameters for **IP Address**, **Subnet Mask**, **Default Gateway**, and **Configuration Server**.
3. For **DHCP Setting**, select the **off** radial button.
4. Click **SAVE** and confirm the operation.
If you modify any parameters, the base station reboots.

Chapter 4: Hardware preparation and installation

Overview

The following sections contain all the relevant information pertaining to installing the base station, determining the installation scenarios, powering and booting the base station, discovering IP Office, and more.

The first step toward successfully installing a base station is to consider the installation scenarios. Once you determine the scenario that best suits your environment, plan the site for deployment using a floor plan.

You can perform site surveys in the environment to assist you with the site and floor planning. Using the handset, you can perform a DECT site survey to determine the number of slots available in the 12-slot DECT frame. You can also perform a base station survey to count the number of base stations that exist within range of the handset performing the survey.

After you plan the site, register the handsets to the correct base station as identified by your floor plan. When registering repeaters, first determine the appropriate installation scenario. You should register the repeaters prior to deployment to avoid unnecessary traveling between repeater and base station. After you determine either long and narrow coverage or broad coverage, and prior to mounting any repeaters, you can use a signal strength survey to test the desired location. If you determine that the location receives an adequate signal from the base station, test and mount the repeater.

 **Danger:**

Never install electrical cords across traffic areas where they cause a trip hazard. If the cords are damaged, they can create fire or electrical hazards.

Related topics:

[Site planning](#) on page 30

[Base station installation](#) on page 36

[Handset registration](#) on page 43

[Signal strength survey](#) on page 46

[Repeater installation](#) on page 47

Site planning

Prior to deploying a base station and installing repeaters at a site, you must ensure that the site is prepared to support the D100 and its DECT equipment. You must choose a location for the base station that is central to the users and the coverage area. The best method to determine the location of the DECT equipment is to use a floor plan. See [Using a floor plan](#) on page 31.

You can perform a DECT site survey using the handset to confirm that the DECT RF spectrum is not already fully in use by other equipment in the area. See [Performing a DECT site survey](#) on page 34 and [Performing a base station survey](#) on page 35.

Empty site survey results differ from those of the same site once occupied. Perform the survey during normal business hours in order to assess the areas of usage and the effect of operating and moving equipment.

Repeater installation

If you want to extend the range of the base station by using repeaters, you require repeaters for each base station in use. You should register repeaters prior to deployment to avoid unnecessary travel between the base station and the repeater after the repeater is mounted.

The system supports handset roaming and hand-off between a base station and its repeaters. A repeater must be within the cell radius of the base station to which the repeater registers, and subsequent linked repeaters must be within the cell radius of the previous repeater.

A repeater can handle up to four channels, and you can register up to six repeaters to each base station. Note that a chain of linked repeaters is also limited to four channels, since all channels are carried by the first repeater in the chain.

You must place the repeaters in a location that maximizes the number of available channels, while placing the initial repeater within the cell radius of its base station. Note that you can only link up to three repeaters in a row and that each repeater must be within the cell radius of the other repeater.

Repeater installation scenarios:

- **Long and narrow coverage**

In a situation where you are attempting to cover a long and narrow area with equal coverage, you must place the base station in the middle of the coverage area and extend repeaters in both directions outward. This reduces the amount of linking. If you find that you require too many repeaters, or you have more than eight active channels, you might install an additional base station.

For example,

- *Scenario 1:* RP3 — RP1 — **BS** — RP2 — RP4

is far preferable to

- *Scenario 2:* **BS** — RP1 — RP2 — RP3

because in the second scenario you can place, on average, only one channel per repeater, whereas in the first scenario, you can place, on average, two channels per repeater.

- **Broad coverage**

In situations that require broader coverage, for example if you require too many repeaters to extend the range of coverage or you have too many users, you must use an additional base station. Bear in mind that each base station requires its own repeaters.

Obvious causes of signal problems

The base station and its repeaters must be no closer than 17 feet (5 meters) from other DECT base stations and repeaters, including other D100s on the same IP Office.

The repeaters registered to a particular D100 base station must be at least 35 feet (10 meters) from the base station, and 35 feet (10 meters) from other repeaters. This range limitation is particularly important in multi-floor deployments.

The following can also cause signal problems:

- Metal surfaces
- Concrete thickness greater than three feet (one meter)
- Windows with reflective film or specialized glass produce increased signal reflection and reduced signal pass-through.
- Wire meshes and grills with apertures of less than 4cm (1.5 inches) obstruct signals as effectively as continuous sheet metal.
- Fire doors can block the signal. In multi occupancy buildings, such as hotels, the high number of fire doors might be a problem.
- Stairwells, such as in modern office buildings, frequently combine concrete building supports, fire doors, and the intervening floor material. This can be especially problematic.
- Screened rooms, such as those typically found in offices involved with TV, video, and radio production, can cause signal interference.

Related topics:

[Using a floor plan](#) on page 31

[Performing a DECT site survey](#) on page 34

[Performing a base station survey](#) on page 35

Using a floor plan

To obtain the best possible performance, you must install all of the base stations in a location that provides proper coverage. You should use a floor plan to determine the location for the base stations. Perform the following steps:

Procedure

1. Draw a floor plan of your environment.

2. Identify all of the people in the environment who will use a D160 handset.
3. Identify the location where you want to install a base station.
Start with one base station and determine the coverage of that base station in step 4, then include additional base stations, if necessary.

The following image demonstrates the floor plan for a sample company.

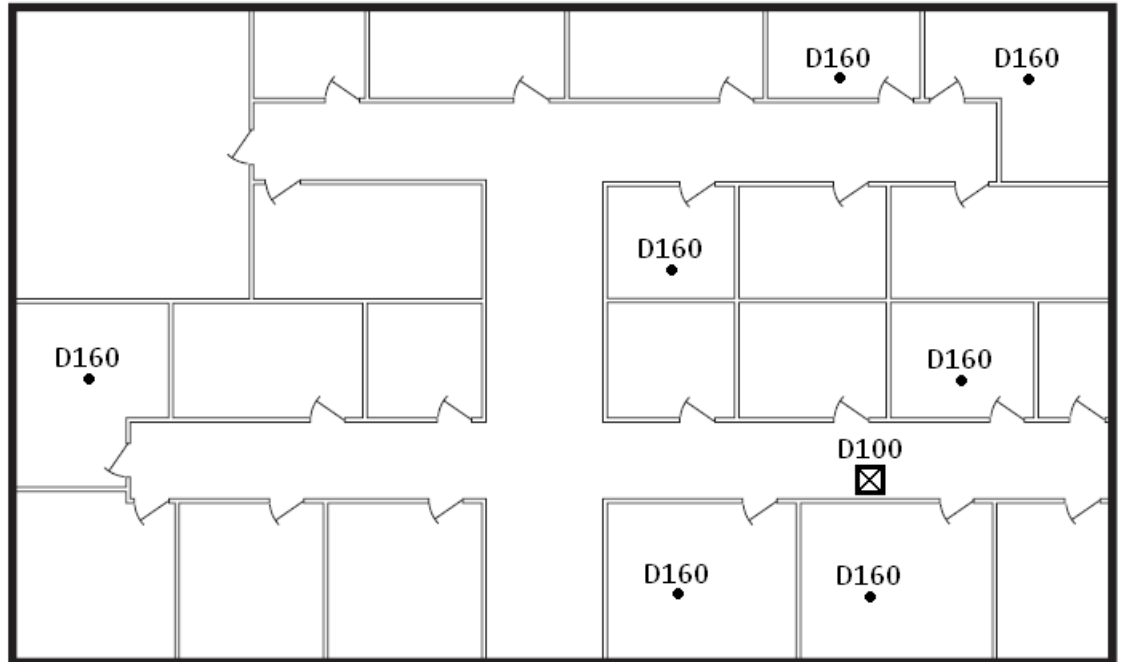

4. Using the base station as the center, draw a circle with 160 foot (50 meter) radius. This circle indicates the typical coverage area of the base station. Note that the coverage area goes in all directions, horizontally and vertically. The following image demonstrates a complete floor plan showing coverage for a single base station.

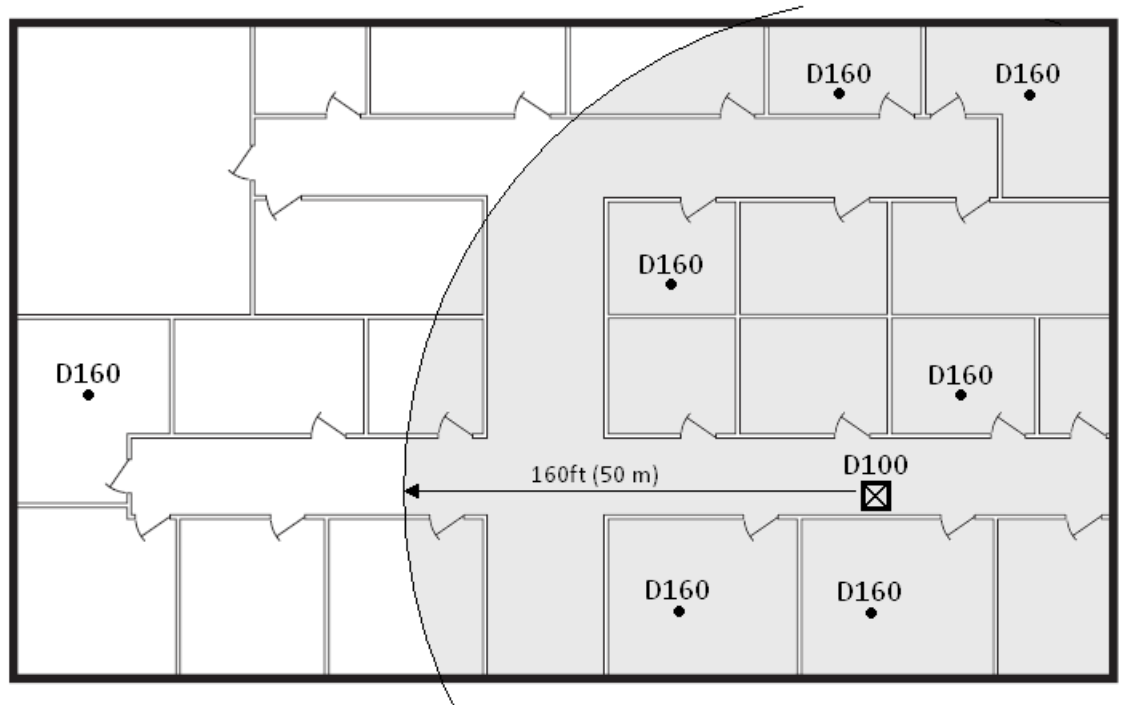

5. Verify whether the circle encompasses all of the areas that will use a handset. If the circle does not encompass all of the areas, you must modify the floor plan to accommodate another base station or a repeater. The following image demonstrates a modified floor plan that accommodates a repeater. Note that some areas still do not receive full coverage.

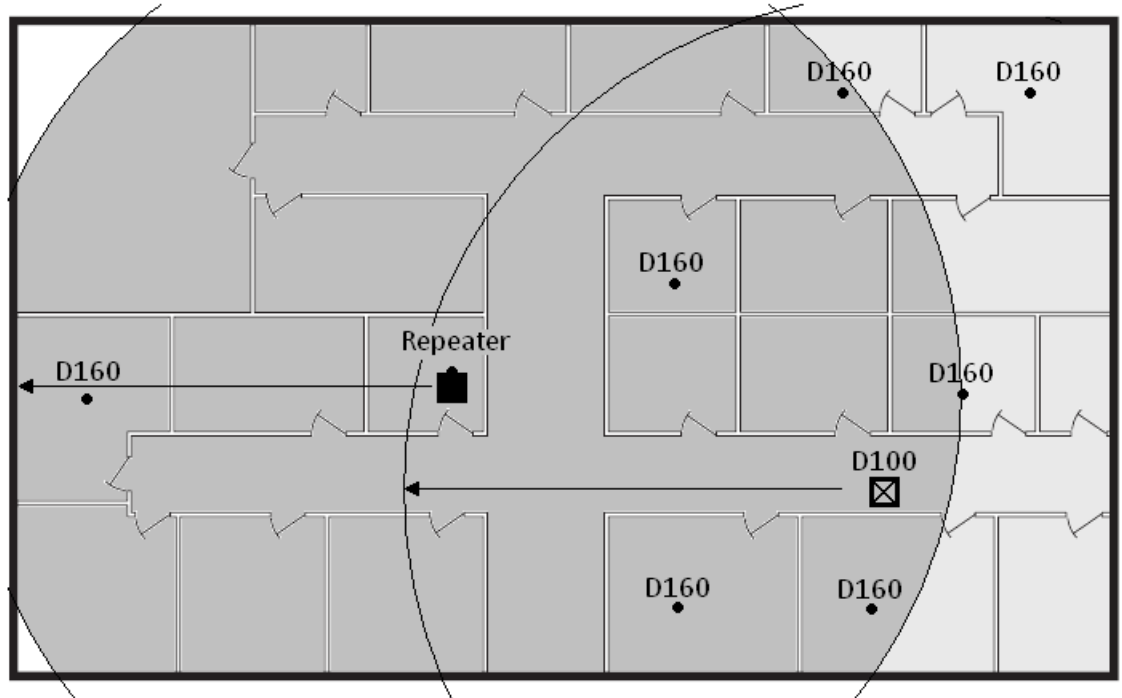

*** Note:**

The base station and its repeaters must be no closer than 17 feet (5 meters) from other DECT base stations and repeaters, including other D100s on the same IP Office.

The repeaters registered to a particular D100 base station must be at least 35 feet (10 meters) from the base station, and 35 feet (10 meters) from other repeaters. This range limitation is particularly important in multi-floor deployments.

Performing a DECT site survey

You can use the following procedure to confirm that the DECT RF spectrum is not fully used by other DECT equipment in the area. Perform the site survey if there is likely to be a number of other DECT systems in the area. Also, it is recommended that you perform the survey during normal site operation.

The handset can measure the RSSI of all channels within one slot. If the RSSI value calculated is under -60dBm for at least one channel, that slot is determined to be a clear slot. This process is repeated for all slots, after which the handset displays the number of clear slots.

Procedure

1. Press and hold the * and # keys and insert the battery into the handset at the same time.
2. Depending on your place of residence:
 - Press soft key #1 to start the measurement for a North American site.
 - Press soft key #2 to start the measurement for a European site.

The measurement occurs quickly and then the handset display shows the results. The top line of the display shows the number of clear slots, and the second line of the display shows the number of clear channels and the associated slots. For example:

```
NA Clear Slot: 12 / 12
```

```
544333444555 49 / 60
```

This example indicates the following:

- The survey has completed on a North American site.
- All 12 slots had at least one free channel.
- All five channels were free on slots 1, 10, 11, and 12.
- Four channels were free on slots 2, 3, 7, 8, and 9
- Three channels were free on slots 4, 5, and 6.

* Note:

The site should have at least 10 clear slots in order for the D100 to work properly.

3. Press the soft key used in step 2 to restart the survey. In North America, you can press soft key 3 to continue with a base station survey. See [Performing a base station survey](#) on page 35.
Press the **On-Hook** key to return the handset to normal operating mode.

Performing a base station survey

Use the following procedure to confirm that the DECT RF spectrum is not fully occupied by other DECT base stations in the area.

* Note:

The D100 only supports survey mode on North American band frequency.

Procedure

1. Press and hold the * and # keys and insert the battery into the handset at the same time.
2. Press soft key #3.
The handset begins to count, or “rake”, the available RFPI and lists the results on the display.
3. When complete, the handset reads **Stop Raking RFPI** followed by the number of RFPIs detected.

*** Note:**

In order for the D100 to work reliably, the number of RFPIs detected in the site should be less than or equal to 40.

4. Press soft key #3 to restart the process.
Press the **On-Hook** key to return the handset to normal operating mode.

Base station installation

Install the base station in a location that provides the least amount of interference. See [Site planning](#) on page 30. Before you install a base station, you must understand the usage scenarios so that you can determine whether or not the environment is acceptable. Bear in mind the following:

- **Signal direction:** The signal from a base station does not propagate evenly in all directions. The signal typically propagates strongest in the horizontal plane. However, the base station might be able to serve callers on other floors. You can then provide coverage to areas not frequently used and so not meriting a dedicated local base station.
- **Other radio signals:** Receiving normal broadcast radio signals in an area is not an indication that the base station will receive DECT signaling.

You can install the base station simply by plugging in the required connectors but you must first determine the coverage area. Prior to installing the device, you can deploy various surveys to detect the number of available channels in the environment as well as any pre-installed base stations. See [Performing a DECT site survey](#) on page 34 and [Performing a base station survey](#) on page 35.

Related topics:

- [Base station installation scenarios](#) on page 37
- [Mounting the base station](#) on page 39
- [Powering the base station](#) on page 41
- [Booting up](#) on page 42

Base station installation scenarios

You must install the base station in a proper environment. Consider the following deployment scenarios prior to installing a base station.

Note that a single IP Office supports up to four base stations.

Isolated locations

In this installation scenario, base stations cover two separate areas. Users from one area do not get coverage in the other. Note that both base stations register to the same IP Office.



Adjacent locations

In this installation scenario, base stations cover two adjacent areas. Repeaters provide coverage for users outside of the cell radius of the base station. These repeaters must be within the cell radius of the base station, and additional repeaters must be within the cell radius of the linked repeater.



Same location

In this installation scenario, an additional base station adds users to an existing coverage area, where the number of users surpasses the number supported by a single base station. This scenario might require repeaters, but a repeater can only register to a single base station.

Each base station in this scenario must be at least 17 feet (5 meters) away from each other.



Mounting the base station

You can mount the base station on a wall or ceiling, or set on a flat surface. Prior to mounting the base station, consider the following:

- A location that is higher than cubicle wall height provides better coverage.
- The base station must be readily accessible for resetting and registration procedures.
- The base station receives power through PoE, so the base station must be within range of the Ethernet cable providing the power.

Beware of metal surfaces or concrete thickness greater than 3 feet (1 meter) that might cause signal interference.

Note that multiple base stations in the same location must be at least 17 feet (5 meters) away from each other.

Ensure that you register the appropriate repeaters prior to mounting the base station in the environment. Registering repeaters prior to mounting the base station helps to avoid signal disruptions and unnecessary traveling between repeater and base station. See [Repeater registration](#) on page 48.

Standing the base station on a flat surface:

- To stand the base station on a flat surface, first plug the Ethernet cable into the slot on the back of the base station until you hear it click.



- With the Ethernet cable connected, snap the base attachment into the bottom of the base station and route the cable through the slot in the stand.



- Stand the base station vertically on its base and ensure that the Ethernet cable is not disrupted.

Mounting the base station on a wall or ceiling:

To mount the base station on a wall or ceiling, use the following procedure. Note that you will not require the base attachment.

Before you begin

Refer to the following diagram to determine the required mounting space for the base station, which is 12 cm (4.7 in) by 20.3 cm (8 in).

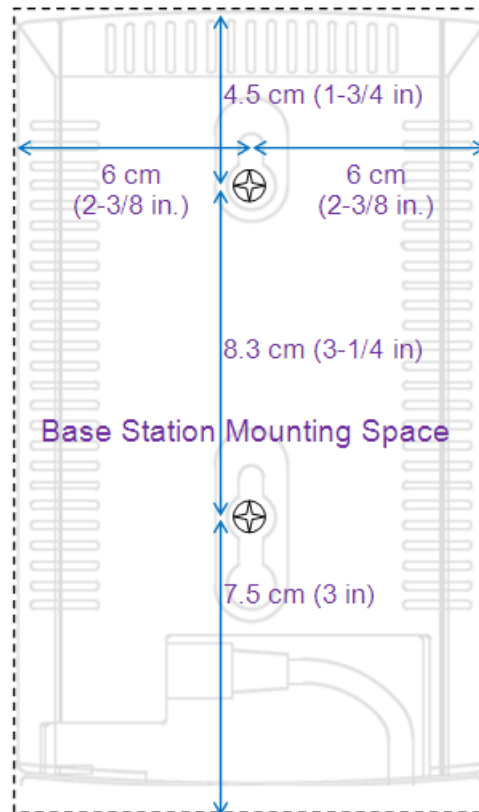

Procedure

1. Screw the mounting screws directly into the wall or ceiling, or using the wall anchors provided. Install the screws 8.3 cm apart vertically, in a space that has 4.5 cm clearance above the top screw, 6 cm clearance to either side, and 7.5 cm clearance below the bottom screw.
Leave the screw heads about 2 mm out from the mounting surface.
2. Plug the Ethernet cable into the slot on the back of the base station until you hear it click.
3. Ensure that the cable is securely attached and not disrupted, then mount the base station on the screws installed in step 1.

Next steps

After installing and connecting the base station to IP Office, register the handsets and install the appropriate repeaters for that base station.

Powering the base station

The base station receives power through the Ethernet cable using Power over Ethernet (PoE). Ensure that you plug the provided cable into a PoE-enabled switch that connects to the network

where IP Office resides. Alternatively, you can use a PoE Power supply with a non-PoE Ethernet interface.

Connect the Ethernet cable to the input on the back of the base station. The power LED should turn on.

Booting up

The following sections identify the boot up sequence and the IP address decision schemes that you require to install the D100 successfully. For information about LED behavior, which can be of assistance when determining the device state, see [Display properties](#) on page 15.

Before you begin, ensure that you configure IP Office according to the appropriate deployment scenario. For more information, see [System configuration](#) on page 19.

Related topics:

[Boot up sequence](#) on page 42

Boot up sequence

Use the following procedure to boot up the base station.

Before you begin

Ensure that you have the required components:

- D100 base station
- D160 handset
- Ethernet cable for PoE

Procedure

1. If DHCP is enabled, the base station obtains the IP address from the DHCP server.
If DHCP is disabled, the base station begins to boot up with the IP address that was provided in advance. The status LED flashes to indicate the booting status.
2. If the current IP parameters of the base station differ from those parameters received from IP Office, the base station loads the new parameters and reboots.
If the firmware version number is different from the version of the base station, the firmware is updated and then the base station reboots.

While setting up IP Office, the LEDs of the base station turn on to indicate that the base station is setting up. After the IP Office setup is complete, the status LED turns on to indicate that the base station is ready. Users can now log in.

Handset registration

The following sections explain how to perform DECT registration and de-registration directly on the D160 handset, as well as de-registration using System Status Application. Note that registration and de-registration will not affect registered phones or calls in progress.

Prior to registering a handset, ensure that other DECT equipment in the environment has Registration mode disabled or the equipment could cause a disruption.

Related topics:

[Powering the handset](#) on page 43

[Registering a handset using the handset](#) on page 43

[De-registering a handset using the handset](#) on page 44

[De-registering a handset using System Status Application](#) on page 45

Powering the handset

Insert the D160 battery into the handset to begin handset operation.

- Use only the D160-compatible battery.
- Fully charge the battery before use.
- When the battery no longer holds a charge, dispose of the battery responsibly.

Registering a handset using the handset

You can register a D160 handset using the following procedure.

Before you begin

Ensure that your device is not connected to a base station. The handset display should read **Not Registered** or **Searching**. If at any time the registration process fails, the handset display reads **Registration Failed** and the device returns to an Unregistered or Searching state.

Procedure

1. While the handset is in an Unregistered or Searching state, press the **Regist** soft key.
The handset display flashes a message that reads **Press Reg. Key On Base**.
 - If the handset is in a Searching state, the handset is attempting to find a new base station. Press the **Regist** soft key followed by the **OK** soft key to continue with the registration procedure.

2. Press and hold the **Registration** key on the front of the base station for approximately three seconds until the LED blinks.
 - Alternatively, you can use System Status Application to enable Registration mode on the handset. See [System Status Application](#) on page 56.

The base station automatically exits registration mode when no handset or repeater registrations have been performed for over two minutes.

3. After the handset finds the base station, you must enter the four-digit DECT PIN code and press **OK**. If the base station uses the default DECT PIN code, you can press the **Deflt** soft key.
The **Cancel** or **On-Hook** soft keys cancel the registration process.

*** Note:**

You have 30 seconds to enter the four-digit DECT PIN code before the handset returns to Unregistered mode. For more information, see [Administrator settings](#) on page 60.

After registration is complete, the handset enters a logged-out state, ready for a user to log in.

De-registering a handset using the handset

You can perform de-registration on the handset using the following procedure. Note that de-registration does not affect calls in progress.

Procedure

1. From either the Idle or logged-out state on the handset, press the **Config** soft key.
The display reads **Configuration...** while the handset attempts to connect to the base station.

Press the **On-Hook** key to quit de-registration at any time.
2. After connecting to the base station, the handset display provides a menu list that you can navigate using the **Next** and **Prev** soft keys. Navigate to **Administrator Setting** and press the **Select** soft key.
3. Enter the administrator password and press **OK**.
By default, the administrator password is **7 8 2 8 8 7 6** (or 'QUATTRO'). For more information, see [Administrator settings](#) on page 60.

Only one handset per base station can enter the **Administrator Setting** menu at any given time. Attempts to enter the menu on additional handsets result in the message **Denied**.

4. After the password is authenticated, navigate to **Deregistration** and press **Select**.
The display shows the handset information, which includes the handset number and the user extension number, if a user is logged in.
5. Scroll through the list of handsets using the **Next** and **Prev** soft keys. Select one of the handsets for de-registration using the **Select** soft key.
An asterisk (*) next to the handset number in the list identifies the handset in use.

The following table identifies the handset states relative to the **Extension Number** field:

No.	Handset state	Extension Number field
1	Not registered	Not displayed on the handset de-registration list
2	Registered but not logged in *	Empty
3	Registered and logged in *	<extension number> **
<p>* You can de-register a handset whether or not its user is logged in, and whether or not a user is associated with the device. Attempting to de-register a handset that is not registered results in an error tone and you will not be able to proceed to the next step.</p> <p>** <extension number> represents the actual extension number of the user who is logged in.</p>		

6. Select the handset you wish to de-register and press **OK** to execute de-registration. Press **Back** to quit de-registration and return to the menu list.
7. After de-registration, the handset emits a confirmation tone and displays a message for three seconds that reads **Deregistered:#1** before returning to the menu list.
The handset, in this case handset **#1**, enters an unregistered state.

De-registering a handset using System Status Application

You can also perform handset de-registration using System Status Application (SSA). Use the following procedure. Note that de-registration does not affect calls in progress.

Procedure

1. Open System Status Application and select the base station to which the handset is registered under **System > SIP DECT Base Stations**.
2. Highlight the handset you wish to de-register.
3. Click the **Unregister Handset** button.

*** Note:**

You might have to expand the System Status Application window in order to view all of the buttons.

Signal strength survey

The coverage determined during site planning was only an estimate based on the building environment. The planned location of a device might need to change based on the actual coverage. Use the following procedure to verify the coverage of the base station and the repeaters using the Signal Strength Survey mode.

Use any of the handsets registered to a base station to survey the coverage of that base station and its repeaters, and establish where the signal is strongest or strong enough.

Procedure

- Using an idle handset that is registered to the base station being surveyed, press **1+2+3** simultaneously and hold for two seconds. If the display only reads **Searching...**, then the handset is out of range. Otherwise, the handset enters Signal Strength Survey mode and the display reads as follows:

SL-0	RS 2 2	LOCK		
CH 1	CR 3 3	L 0 0	0 0 0 0	NORMAL

*** Note:**

If the **LOCK**, **SL**, or **RFPI** fields show **FF**, then the handset is not connected to the base station or repeaters being surveyed.

- **SL:** Locked Slot — Slot Number: 0–B
- **CH:** Channel — Channel Number: 0–4 (NA), 0–9 (EU)
- **RS:** RSSI average — Received Signal Strength Indicator (0x15 – 0x3B)

Install base stations and repeaters such that the RSSI for each device is at least 22 everywhere within the coverage area.

- **CR:** CRC — (0x00 – 0x40). A value of 40 indicates an error-free signal quality.

Install base stations and repeaters such that the signal quality for each device is near 40 everywhere within the coverage area.

- **LOCK:** UCP state — LOCK (connected) or SRCH (searching)

- **L:** Lost Counter — Lost frame counter
- **0000:** Base RFPI — If the last character is a '0' the survey is monitoring the base station. Otherwise, it is monitoring a repeater. A unique value indicates each repeater.

2. Press one of the following soft keys to enter the mode described:

- **Soft key 1:** The handset enters the Normal mode where the handset is handed off to repeaters in the same way that would occur during normal use. This mode is helpful in understanding hand-off areas on the site.
- **Soft key 2:** The handset enters the Hold mode. The Hold mode suspends handset hand-offs to other repeaters or base stations and continues to monitor the same signal source, regardless of strength or error rate. Use this mode to determine a particular device's coverage area.
- **Soft key 3:** The handset enters the Peak Search mode, where the handset connects to the device with the highest-strength signal. The handset then enters the Normal operating mode. Use this feature to connect to the nearest device immediately.
- **Soft key 4:** Press **4** to alternate between the Normal and Hold modes.

Repeater installation

A successful registration results in the blue LED on the repeater flashing three times, then the LED turns solid to indicate that the repeater has connected to the base station. A failed registration, which can occur if the repeater cannot find a base station to register with, results in 10 fast flashes of the blue LED before the repeater returns to its original state. The blue LED flashes slowly to indicate that the repeater is registered and is searching for the base station, or that the repeater is in the process of connecting to the base station.

You do not need to de-register repeaters. The base station only keeps track of repeaters that register to the base station. The base station overwrites repeater registration parameters each time a repeater registers.

*** Note:**

When a base station reboots, the base station determines the repeater topology. If you move repeaters, you should reboot the base station so that it can adjust to the change in topology. When you reboot a base station, all linked repeaters enter a searching mode and choose the most appropriate master unit.

When a repeater is not registered, the repeater LED blinks once when the power is connected and then stays off. To register a repeater to a base station, see [Repeater registration](#) on

page 48. For instructions on performing the survey and determining the strength of the available signals, see [Signal strength survey](#) on page 46.

Related topics:

[Repeater registration](#) on page 48

[Testing the repeater location](#) on page 48

[Mounting repeaters](#) on page 50

Repeater registration

Use the following procedure to register a repeater. Remember that each base station can support a maximum of six repeaters, and that you can chain-link up to three repeaters. When a repeater is powered, the repeater immediately attempts to find the base station it is registered to. The repeater keeps track of the base station to which it is registered.

To avoid signal disruptions, you should register a repeater prior to deploying the repeater.

Procedure

1. Press and hold the **Registration** button on the front of the base station until the base station power LED flashes.
2. Press and hold the **Registration** button on the back of the repeater until the repeater LED flashes.
When the repeater successfully registers, the repeater LED flashes three times. The repeater connects to the base station to which it was previously registered, and the repeater LED changes from flashing to solid, indicating that the repeater is now registered.

If the repeater fails to register with a base station, the repeater LED blinks 10 times and the repeater returns to its previous registration state, i.e. Searching or Connected if already registered with a base station, or Unregistered if not registered with a base station.
3. Repeat step 2 for each repeater in the system.
4. Once all of the repeaters have registered, confirm the registration. Turn off the base station to which the repeaters are registered by disconnecting the Ethernet cable, and then confirm that the repeaters for that base station enter the Searching mode.

Testing the repeater location

After registering but prior to mounting a repeater, you can test the location to see if the signal from the base station is sufficient to handle calls. You should perform the test because the

repeater might be too far away from the base, electronic devices might cause an interference, or thick walls or metal objects might block the signal.

Here are some tips:

- Place the repeater as high as possible, at least six feet off the ground.
- Allow at least 35 feet (10 meters) between repeaters, horizontally and vertically.
- Avoid sources of electrical interference, such as office equipment or microwave ovens.
- Avoid heat sources and direct sunlight.
- Avoid things that can interfere with radio signals, such as metal doors, thick walls, screened rooms, niches, and cupboards.
- Ensure that the wall material can hold the weight of the repeater. Never install a repeater in damaged or decaying wall material.
- Ensure that a standard 120V AC wall outlet is within reach of the repeater.

If you are installing multiple repeaters, perform the following test on each repeater.

 Danger:

Never install electrical cords across traffic areas where they cause a trip hazard. If the cords are damaged, they can create fire or electrical hazards.

Procedure

1. Plug the repeater's AC adapter into a standard 120V AC wall outlet.
 2. Using a handset, perform a site survey to determine a location with adequate signal strength to support the repeater.
The signal strength should be at least 22 and error free. See [Signal strength survey](#) on page 46. If the signal strength or quality is too low, choose a location closer to the base station or linked repeater, or one with less obstruction.
 3. Hold the repeater in the place where you plan to mount it.
 - If the repeater LED remains on and steady, the repeater is receiving a good signal from the base. You can mount the repeater in that location.
 - If the repeater LED flashes, the repeater is not receiving a good signal from the base. Move the repeater to another location and repeat the test. If problems persist, ensure that the repeater registers to the same base station as the handset used for the signal strength survey.
-

Mounting repeaters

You can mount the repeater on a wall or ceiling. Determine the following when choosing a location to mount the repeater:

- A location that is higher than cubicle wall height provides better coverage.
- The repeater power supply cord is 2 metres (78 in) long, so you should mount the repeater within 2 metres (78 in) of an outlet.

Beware of metal surfaces or concrete thickness greater than 3 feet (1 meter) that might cause signal interference.

Note that a repeater must be no closer than 35 feet (10 meters) from the base station or another repeater on the same base station. Also, the repeater must be no closer than 17 feet (5 meters) from other DECT equipment.

Before you begin

Ensure that you have the necessary screwdriver to use with the two mounting screws supplied with the repeater.

Refer to the following diagram to determine the required mounting space for the repeater, which is 15 cm (6 in) by 11.4 cm (4.5 in).

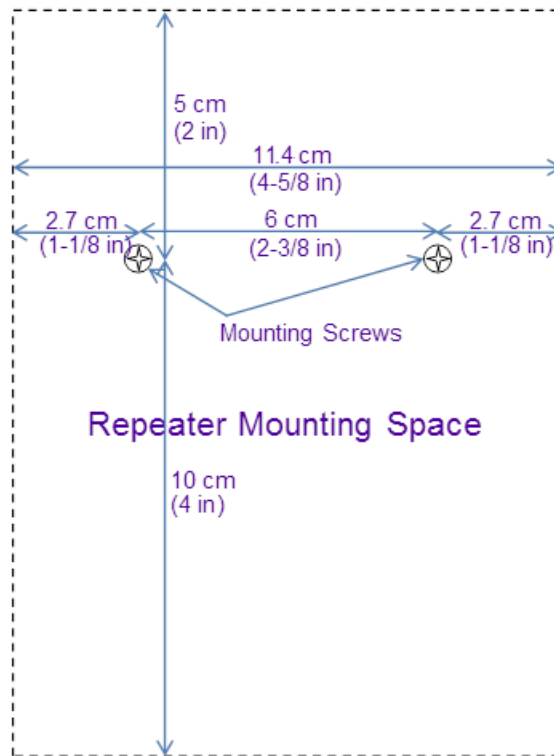

Procedure

1. Screw the mounting screws directly into the wall or ceiling, or using the wall anchors provided. Install the screws 6 cm apart horizontally, in a space that has 5 cm clearance above the screws, 2.7 cm clearance to either side and 10 cm clearance below.
Leave the screw heads about 2 mm out from the mounting surface.

Leave the screw heads about 2 mm out from the mounting surface.

2. Gently remove the adapter cover from the back of the repeater by pushing in and up on the ribbed section, indicated by an arrow in the following image.

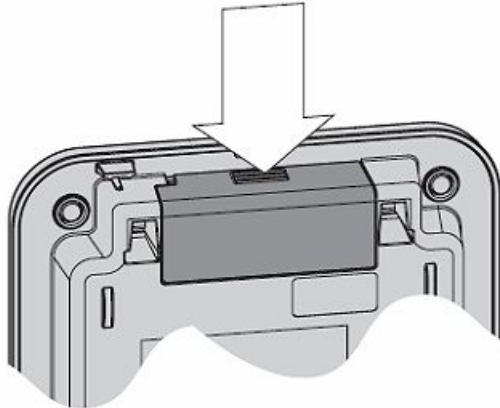

3. Plug the AC adapter connector into the yellow adapter opening, as in the following image:

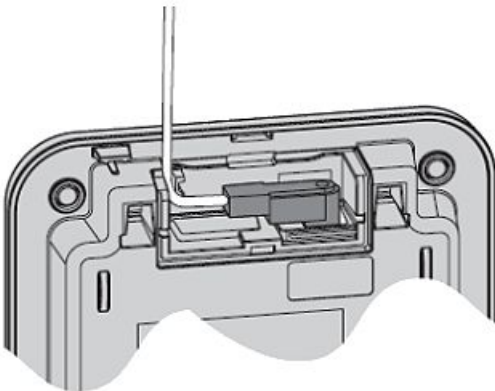

4. Without inserting the cover on an angle, carefully replace the adapter cover, and press on it until you hear it click.
5. Mount the repeater on the mounting screws installed in step 1.
6. Plug the power supply into the nearby outlet and dress the power cable.
For EU models, install the appropriate plug into the repeater power supply adapter.
7. If the repeater is registered, ensure that the repeater connects properly with the base station. If it is not registered, see [Repeater registration](#) on page 48.

If the repeater links from another repeater, ensure that the linking repeater is installed, registered, and connected.

The repeater blue LED should be on, but not flashing.

Chapter 5: Coverage information

Out of range

When the handset is in an Idle state and the display reads **Searching** it means that the handset cannot find its base station as it is most likely out of range. If you press the **Regist** soft key, the handset enters the registration mode to register to the new base station. To complete registration, the base station must also be put in registration mode. When the new registration is successful the handset overwrites the previous registration information. If the new registration is unsuccessful, nothing changes.

Use the following sections to troubleshoot various out of range scenarios.

Out of range while establishing an RF link

If you press a button but the handset cannot establish an RF link with the base station, the handset emits an error tone and the display reads **Out of Range**.

Out of range while talking

If the handset does not receive a signal from the base station in approximately five seconds, the handset terminates the call and the handset reverts to the Searching mode.

Likewise, if the base station does not receive a signal from the handset in approximately five seconds, the base station terminates the call.

Out of range while configuring

If the handset cannot receive a signal and reverts to an out of range state while configuring settings in the menu, the handset does not save any of the settings configured prior to confirmation.

Chapter 6: Administration and maintenance

Overview

The following sections contain all of the relevant information pertaining to the administration and maintenance of a D100 device.

Use System Status Application (SSA) as the preferred method to monitor and check the status of D100 systems after they register to IP Office. Prior to registration, you must use IP Office Manager to administer the system. SSA provides real-time status, historic utilization, and alarm information for ports, modules, and expansion cards on the system. Using SSA, you can refresh the base station, reset to factory defaults, register handsets, and more.

You can also perform various administrative actions on the D160 handset. However, you should only perform administration on the handset in troubleshooting scenarios where you cannot reach IP Office Manager but you need to determine settings on the device. Some of the administrative changes you make on the handset revert when the base station reboots.

You can use the Base Station Web Management Interface to access various management functions on the D100, including configurations, logging information, rebooting, and updating firmware. Note that you must be an administrator in order to view and utilize the Base Station Web Management Interface due to the sensitivity of the information contained within. Much like performing administrative actions on the handset, rebooting the base station overwrites the changes made using the Base Station Web Management Interface.

Use the information in the following sections to administer and maintain the system, as well as to update the base station and handset firmware.

Related topics:

[System Status Application](#) on page 56

[Administration on the handset](#) on page 59

[Base Station Web Management Interface](#) on page 71

[Updating base station firmware](#) on page 75

[Updating handset firmware](#) on page 76

System Status Application

System Status Application (SSA) is a diagnostic tool for system managers and administrators to monitor and check the status of IP Office systems, locally and remotely. Avaya recommends using SSA as the preferred method for administering the D100 after the device is connected and registered to IP Office.

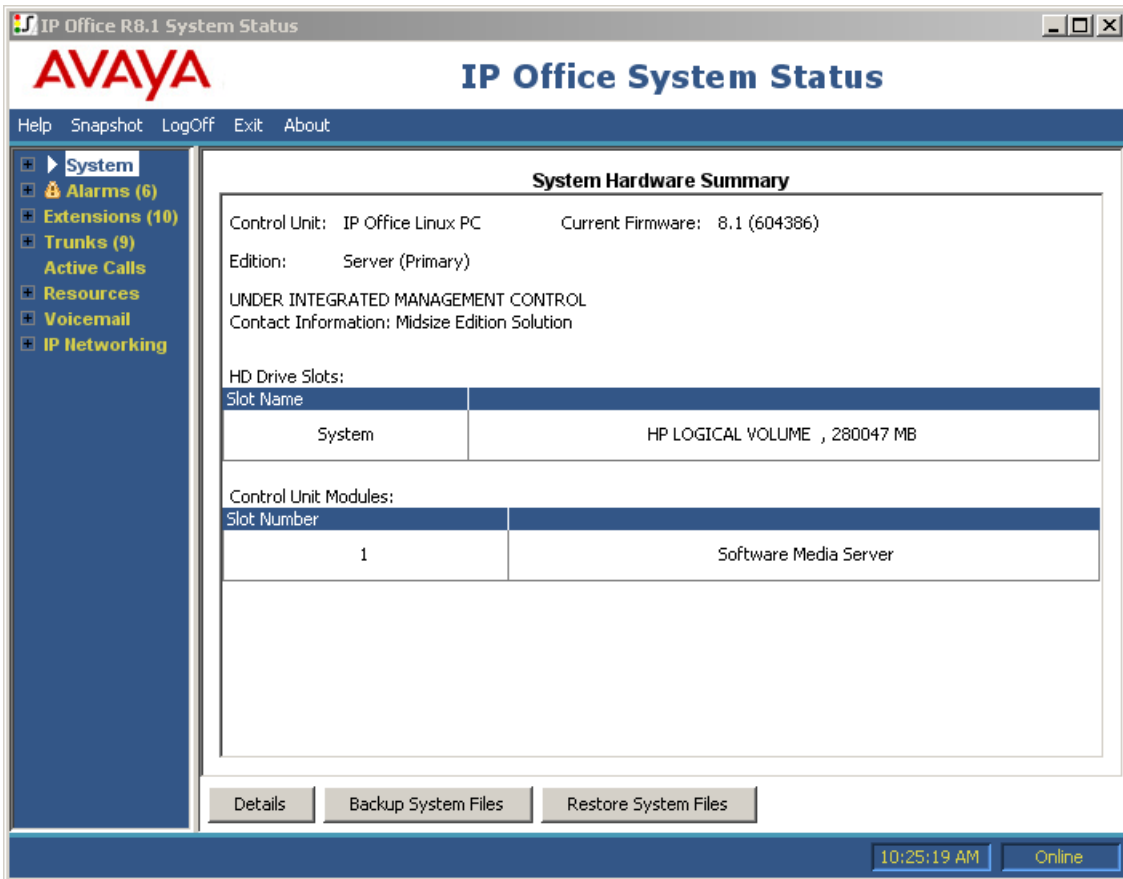

System Status Application shows both the current state of an IP Office system and the details of any problems that have occurred. The report consists of real-time events, historical events, status data, and configuration data to assist in troubleshooting and diagnoses. SSA provides real-time status, historic utilization, and alarm information for ports, modules, and expansion cards on the system.

The following sections outline the status pages relevant to D100 administration.

SIP DECT Base Stations status page

Click the plus **[+]** icon next to **System** in the side menu and select **SIP DECT Base Stations** to view a list of base stations connected to that IP Office.

IP Office R8.1 System Status - Apollo Primary (47.135.151.150) - IP Office Linux PC 8.1 (604386)

AVAYA IP Office System Status

Help Snapshot LogOff Exit About

System

- Hard Disks
- VoIP Trunks (9)
- H.323 Extensions
- SIP Extensions
- SIP DECT Base Stations
 - D100_Anne
 - D100Brian
- Alarms (7)
- Extensions (10)
- Trunks (9)
- Active Calls
- Resources
- Voicemail
- IP Networking

Select a base station to display the Base Station Status

Name	Line Number	IP Address	Firmware Version
D100_Anne	230	47.123.123.8	D100_0.7.9_0.7.9
D100Brian	231	0.0.0.0	

Refresh Select Allow Registration

Reset Base Reset Base To Default Reset Base Admin Pass

1:45:27 PM Online

This page contains detailed information about each base station and the related Line number, IP address, and firmware version. Highlight a base station to reveal the six following options. Note that you might have to scroll the page or expand the window to view all of the details and options:

- **Refresh:** Refreshes the Base Station Status table.
- **Select:** Opens a Base Station Status page that lists the details of the base station highlighted in the Base Station Status table (see the following section). Alternatively, you can double-click a base station name in the table.
- **Allow Registration:** Enables the Registration mode on the highlighted base station.
- **Reset Base:** Reboots the base station.
- **Reset Base To Default:** Resets the base station to the factory defaults.
- **Reset Base Admin Pass:** Resets the Administrator password to the factory default (7 8 2 8 8 7 6).

Base Station Status page

When you double-click a base station listed in the SIP DECT Base Stations status page, a new page opens with more detailed information for that base station. You can also click the plus **[+]**

icon next to **SIP DECT Base Stations** in the side menu to expand a list of base stations. You need not navigate to the SIP DECT Base Stations status page to obtain the details for each base station.

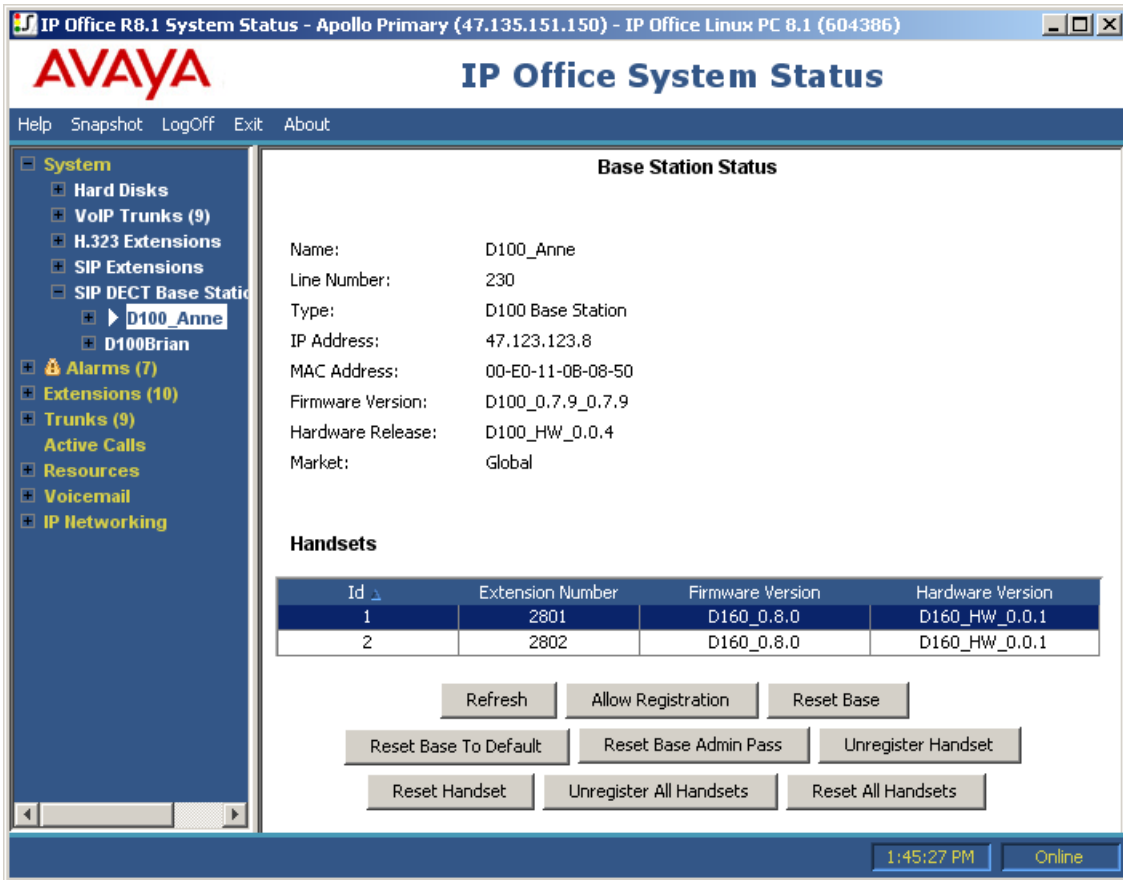

*** Note:**

You might have to scroll the page or expand the window to view all of the details and options available for that base station. You must also highlight a handset for all of the options to become available.

The following options are available, in addition to those described for the SIP DECT Base Stations status page:

- **Refresh:** Refreshes the Base Station Status page and the handset table.
- **Unregister Handset:** Unregisters the selected handset from the base station.
- **Reset Handset:** Resets the highlighted handset.
- **Unregister All Handsets:** Unregisters all handsets from the selected base station.
- **Reset All Handsets:** Resets all the handsets registered to the selected base station.

Administration on the handset

While IP Office Manager is the preferred application for administering the D100, you can perform certain administrative options as well as network configurations directly on the handset. However, when the base station reboots, some of the modified settings revert.

You should only perform administration on the handset in troubleshooting scenarios where you cannot reach IP Office Manager but you need to determine settings on the device.

The administrative settings available include, in order of appearance:

- DECT PIN change
- Administrator password change
- Diagnostics
- Reset base station
- Check firmware update
- Error information

The network settings available include, in order of appearance:

- MAC Address*
- IP Address*
- Subnet Mask*
- DHCP setting*
- Default Gateway*
- SIP Controller*
- Ping Reply setting
- Destination unreachable
- Ethernet information
- Statistics information

* An asterisk (*) indicates a network setting that reverts when the base station reboots.

Related topics:

[Administrator settings](#) on page 60

[Network settings](#) on page 64

Administrator settings

Press the **More..** soft key twice and press the **Config** soft key to enter the **Administrator Setting** menu.

The **Administrator Setting** menu has configurable options and lists of information which only an administrator can reach. Entering the menu requires the use of an administrator password. Since many of the following procedures begin with the **Administrator Setting** menu, do not misplace the administrator password.

By default, this password is **7 8 2 8 8 7 6**. To change the password, see [Administrator password change](#) on page 61.

*** Note:**

The moment you enter the **Administrator Setting** menu on a handset, the system refuses entry to all other handsets connected to that base station. Any attempt to enter the menu on another device results in the message **Denied**.

Procedure

1. In the configuration menu, navigate to **Administrator Setting** and press the **Select** soft key.
2. Enter the administrator password, and press the **OK** soft key. Press the **Del** soft key to delete the last character entered.
By default, the administrator password is **7 8 2 8 8 7 6** (or 'Q U A T T R O').
3. If the password is correct, navigate to the desired menu.
If the password is incorrect, the display reads **Failed** and the handset emits an error tone before returning to the main menu.

Related topics:

[DECT PIN change](#) on page 60

[Administrator password change](#) on page 61

[Diagnostics](#) on page 62

[Reset base station](#) on page 63

[Check firmware update](#) on page 63

[Error information](#) on page 63

DECT PIN change

You can change the DECT PIN using the following procedure. If the system has more than one base station, you should assign each base station a unique DECT PIN to prevent registration to an unintended base station.

* **Note:**

Only the administrator can change the DECT PIN, using the administrator password and the new 4-digit DECT PIN.

Procedure

1. From the **Administrator Setting** menu, use the **Next** and **Prev** keys to navigate to **DECT PIN Change** and press the **Select** soft key.
2. Enter the new 4-digit DECT PIN, or press the **Deflt** soft key.

* **Note:**

If you press the **Deflt** soft key, the handset provides the factory setting PIN (**3 1 0 0**) and requests confirmation. Select **Yes** to confirm or **No** to return to the menu list.

3. If you entered a new PIN, press the **OK** soft key to save the PIN to the base station.
If the PIN change is successful, the handset emits a confirmation tone and the display reads **Saved**. Otherwise, the display reads **Failed**.

Administrator password change

Only an administrator can change the administrator password using the following procedure.

Procedure

1. From the **Administrator Setting** menu, use the **Next** and **Prev** keys to navigate to **Password Change** and press the **Select** soft key.
The system provides a confirmation message.
2. Press **Yes** to change the password.
3. Enter the new administrator password.
The maximum password length is eight characters, but you can enter an empty password. To change the password back to the default setting (**7 8 2 8 8 7 6**), press the **More..** soft key during password entry and select **Deflt**.
4. If you change the password, the handset prompts you to re-enter the password as confirmation. Enter the password a second time and press the **OK** soft key. If you change the password back to the default setting, confirm the change using the **OK** soft key.
If successful, the display reads **Saved** for three seconds. Otherwise, the display reads **Failed** for the same duration. You then return to the menu list.

Diagnostics

The following table contains a summary of the diagnostics available for the D100 base station. If any of the following diagnostic checks fail to complete, reboot the base station. If problems persist, the hardware might need replacing.

The administrator performs the diagnostic checks on the handset through the **Diagnostics** menu, which only the administrator can enter.

Item	Purpose/Behaviour
LED Check	To check the operation of the LED. The Power LED flashes for three seconds, followed by the Status LED for the same duration. The message Checking LED also flashes on the display during the check. If the check fails, the LED does not display the correct status.
KEY Check	To check the operation of the Registration Key on the base station. The display reads Hold Reg. Key . When you hold the Registration key, the base station detects the registration. If the base station fails detection, the Registration key does not perform registration.
RAM Check	To check the status of the RAM. The message Checking RAM flashes on the display. If the check fails, the base station might behave unexpectedly. <i>*Can be run in maintenance mode using the Base Station Web Management Interface*</i>
PHY Check	To check the status of the PHY register. If the PHY check is successful, press the Details soft key to view more information on Link , Duplex , and Speed . If the check fails, the base station cannot connect to IP Office. <i>*Can be run in maintenance mode using the Base Station Web Management Interface*</i>
Flash Check	To check the status of the flash memory. The message Checking Flash flashes on the display. If the check fails, the base station might behave unexpectedly. <i>*Can be run in maintenance mode using the Base Station Web Management Interface*</i>
RF Check	To check the status of the RF register. If the check fails, the base station cannot transmit data to the handset correctly. <i>*Can only be invoked using the Base Station Web Management Interface*</i>

Procedure

1. From the **Administrator Setting** menu, use the **Next** and **Prev** soft keys to navigate to **Diagnostics** and press the **Select** soft key.
2. Navigate the diagnostics submenu and select the desired item using the **Select** soft key.

Use the information in the above table to manage the diagnostics. Press the **Back/Cancel** soft keys or press the **Off-Hook** button to return to the menu list.

Reset base station

Reset the D100 base station using the following procedure on the handset. This procedure restarts the base station but does *not* reset the device to any factory defaults. To reset the device to factory defaults, see [Factory settings](#) on page 79.

Procedure

1. From the **Administrator Setting** menu, use the **Next** and **Prev** keys to navigate to **Reset Base Station** and press the **Select** soft key.
The handset display shows a confirmation message.
 2. Press **Yes** to restart the base station.
Press **No** to return to the menu list.
-

Check firmware update

Use the following procedure to check for new firmware updates. You must be an administrator to access the menu.

Procedure

1. From the **Administrator Setting** menu, use the **Next** and **Prev** soft keys to navigate to **Check Firmware Update** and press **Select**.
The base station checks for a firmware update while the handset display reads **Connecting....** After a short amount of time, the handset display shows the latest firmware version.
2. Press the **Update** soft key to update the firmware. Press the **Back** soft key to cancel the firmware update.
3. Press **Yes** to confirm the firmware update. Press **No** to return to the menu list.
If the current firmware and the latest firmware are the same, the update will not occur and the display will read **The Same Version** for three seconds prior to returning to the menu list.

The base station reboots itself after updating the firmware.

Error information

You can access error information from the Administrator Setting menu. For more information about error messages, see [Handset display reads "No Service"](#) on page 86.

Procedure

1. From the **Administrator Setting** menu, use the **Next** and **Prev** keys to navigate to **Error Information** and press the **Select** soft key.
The handset display lists the error message(s).
 2. Press the **Back** soft key or the **Off-Hook** button to return to the menu list.
-

Network settings

Press the **More..** soft key twice and press the **Config** soft key to enter the **Network** menu.

In the **Network** menu, you can view various network parameters in read-only mode. You can only edit the network settings if you correctly enter the administrator password at the prompt.

You should only configure network settings in troubleshooting scenarios where IP Office Manager and System Status Application are unavailable.

The following submenus are available under the **Network** menu:

- MAC Address
- IP Address
- Subnet Mask
- DHCP Setting
- Default Gateway
- SIP Controller
- Ping Reply Setting
- Destination Unreachable
- Ethernet Information
- Statistic Information

For the changes to take effect, reboot the base station after you make changes to the network parameters.

Caution:

Do not attempt to change IP parameters on the D100 without careful instruction. Be cautious when configuring network settings so as not to corrupt the configuration file.

Procedure

1. From the main menu, use the **Next** and **Prev** soft keys to navigate to **Network** and press the **Select** soft key.
 2. Enter the administrator password, if available.
If you input an incorrect password, the menu opens in read-only mode.
-

Related topics:

[MAC address](#) on page 65

- [IP address](#) on page 65
- [Subnet mask](#) on page 66
- [DHCP setting](#) on page 66
- [Default gateway](#) on page 67
- [SIP controller](#) on page 67
- [Ping Reply setting](#) on page 68
- [Destination Unreachable](#) on page 68
- [Ethernet information](#) on page 68
- [Statistics information](#) on page 69

MAC address

View the MAC address using the following procedure.

Procedure

1. Access the **Network** submenu, navigate to **MAC Address**, and press the **Select** soft key.
The handset display shows the MAC address.

For example: MAC: 00.1A.2B.3C.4D.5E
 2. Press the **Back** soft key to return to the menu list.
-

IP address

View and edit the IP address using the following procedure.

Procedure

1. Access the **Network** submenu, navigate to **IP Address**, and press the **Select** soft key.
The handset display shows the IP address.

For example: IP Addr: 192.168.100.200
2. Administrators have the option to edit the address using the **Edit** soft key.
Otherwise, you can only view and exit the IP address menu in read-only mode and you will not be able to perform the following steps.
3. Press **Edit** and enter the IP address manually using the keypad. The **<<** and **>>** soft keys move the cursor in that direction. Press **More..** to access the **Dot** soft key which you can use to place a dot, or decimal, in the IP address.
4. When you are satisfied with the address, press the **OK** soft key.
If you enter an invalid IP address in step 3, the handset emits an error tone.
5. If the IP address is valid, the handset requests confirmation to complete the change.
Press **Yes** to complete the change or **No** to cancel the change.

The handset returns to the menu list.

Subnet mask

You can view and edit the subnet mask using the following procedure.

Procedure

1. Access the **Network** submenu, navigate to **Subnet Mask**, and press the **Select** soft key.
The handset display shows the subnet mask.

For example: Subnet: 255.255.255.0
 2. Administrators have the option to edit the subnet mask using the **Edit** soft key. Otherwise, you can only view and exit the subnet mask menu in read-only mode and you will not be able to perform the following steps.
Similarly, if DHCP is enabled, the **Edit** soft key will not be available. In this case, press the **Back** soft key to return to the previous menu.
 3. If you press **Edit** you can enter the subnet mask manually using the keypad.
 4. When you are satisfied, press the **OK** soft key.
The handset emits an error tone if you entered an invalid subnet mask in step 3.
 5. If the subnet mask is valid, the handset requests confirmation to complete the change. Press **Yes** to complete the change and **No** to cancel the change.
In either case, the handset returns to the menu list.
-

DHCP setting

View and edit (enable or disable) the DHCP setting using the following procedure.

Procedure

1. Access the **Network** submenu, navigate to **DHCP Setting**, and press the **Select** soft key.
The handset display shows the DHCP setting. The default value is On.

Press the **Back** soft key or the **Off-Hook** button to return to the menu list.
 2. Administrators can enable or disable DHCP by selecting either **DHCP Enable** or **DHCP Disable** using the **Select** soft key. If you did not enter the administrator password, you can only view the DHCP setting in read-only mode.
After selecting a new setting, a confirmation message displays on the handset for three seconds.

The handset emits a confirmation tone before returning to the menu list.
-

Default gateway

View and edit the default gateway using the following procedure.

Procedure

1. Access the **Network** submenu, navigate to **Default Gateway**, and press the **Select** soft key.
The handset display shows the default gateway.

For example: Gateway: 192.168.100.1
 2. Administrators have the option to edit the address using the **Edit** soft key. Otherwise, you can only view the default gateway menu in read-only mode and you will not be able to perform the following steps.
 3. If you press **Edit**, you can enter the default gateway manually using the keypad.
 4. When you are satisfied with the address, press the **OK** soft key.
If you enter an invalid default gateway address in step 3, the handset emits an error tone.
 5. If the address is valid, the handset requests confirmation to complete the change. Press **Yes** to complete the change, or press **No** to cancel the change.
In either case, the handset returns to the menu list.
-

SIP controller

You can view and edit the SIP controller settings using the following procedure.

Procedure

1. Access the **Network** submenu, navigate to **SIP Controller**, and press **Select**.
The handset display shows the SIP controller IP address.

For example: SIP: 192.168.100.100
2. Administrators can edit the SIP controller IP address using the **Edit** soft key. If you are not an administrator, you can only view and exit the SIP controller menu in read-only mode and you will not be able to perform the following steps. Similarly, if DHCP is enabled, the **Edit** soft key will not be available.
3. If you press **Edit**, you can enter the SIP controller IP address manually using the keypad.
4. When you are satisfied, press the **OK** soft key.
If you entered an invalid address in step 3, the handset emits an error tone.
5. If the address is valid, the handset requests confirmation to complete the change. Press **Yes** to complete the change, or press **No** to cancel the change.

The handset returns to the menu list.

Ping Reply setting

The Ping Reply setting determines whether or not the handset responds to a ping. You can effectively 'hide' a handset by disabling its Ping Reply setting. Use the following procedure to enable or disable Ping Reply on a handset.

Procedure

1. Access the **Network** submenu, navigate to **Ping Reply Setting**, and press the **Select** soft key.
The handset display shows the Ping Reply setting. The default setting is **Ping On** (enabled).
2. Administrators have the option to enable or disable Ping Reply manually by selecting either **Ping On** or **Ping Off**.
After selecting the Ping Reply setting, the handset display shows a confirmation message for three seconds.

The handset emits a confirmation tone before returning to the menu list.

Destination Unreachable

View and edit (enable or disable) the Destination Unreachable Internet Control Message Protocol (ICMP) using the following procedure.

Procedure

1. Access the **Network** submenu, navigate to **Destination Unreachable**, and press the **Select** soft key.
The handset display shows the Destination Unreachable setting. The default setting is **On** (enabled).
2. Administrators have the option to enable or disable Destination Unreachable by selecting either **On** or **Off**.
After selecting the Destination Unreachable setting, the handset display shows a confirmation message for three seconds.

The handset emits a confirmation tone before returning to the menu list.

Ethernet information

Use the following procedure to view the Ethernet information.

Procedure

1. Access the **Network** submenu, navigate to **Ethernet Information**, and press the **Select** soft key.
The handset display shows the Ethernet port information as a list of menu items.
2. Navigate the list using the **Next** and **Prev** soft keys and select an item using the **Select** soft key. The items include:
 - **Link: Up** means that the Ethernet link is up. **Down** means that the Ethernet link is down.
 - **Duplex: Full** means that the Ethernet is configured for full duplex. **Half** means that the Ethernet is configured for half duplex.
 - **Speed: 100** means that the Ethernet is configured for 100Mbps. **10** means that the Ethernet is configured for 10Mbps.
 - **Back:** Return to the menu list.

Statistics information

You can view statistics information using the following procedure.

Procedure

1. Access the **Network** submenu, navigate to **Statistics**, and press the **Select** soft key.
The handset display shows the available statistics information as a list of menu items.
2. **Select** an item according to the information below. Press the **Back** soft key to return to the menu list.

Menu item	Description
Recv INVITE	Total INVITE messages received (including retransmission)
Recv Resent INVITE	INVITE retransmissions received
Recv Non-INVITE	Total non-INVITE requests received (including retransmission)
Recv Resent Non-INVITE	Non-INVITE retransmissions received
Recv SIP Res	Total SIP responses received
Recv Resent SIP Res	SIP Responses retransmissions received
Sent INVITE	Total INVITE messages sent (including retransmission)

Menu item	Description
Sent Resent INVITE	INVITE retransmissions sent
Sent Non-INVITE	Total non-INVITE requests sent (including retransmission)
Sent Resent Non-INVITE	Non-INVITE request retransmissions sent
Sent SIP Res	Total SIP responses sent
Sent Resent SIP Res	SIP Responses retransmissions sent
Recv RTP	Total number of received RTP packets
Sent RTP	Total number of sent RTP packets
Recv IP	The total number of received IP packets
Sent IP	The total number of sent IP packets
Recv Ethernet	The total number of received Ethernet packets
Sent Ethernet	The total number of sent Ethernet packets
Recv Error Ethernet	The total number of received error Ethernet packets



Base Station Web Management Interface

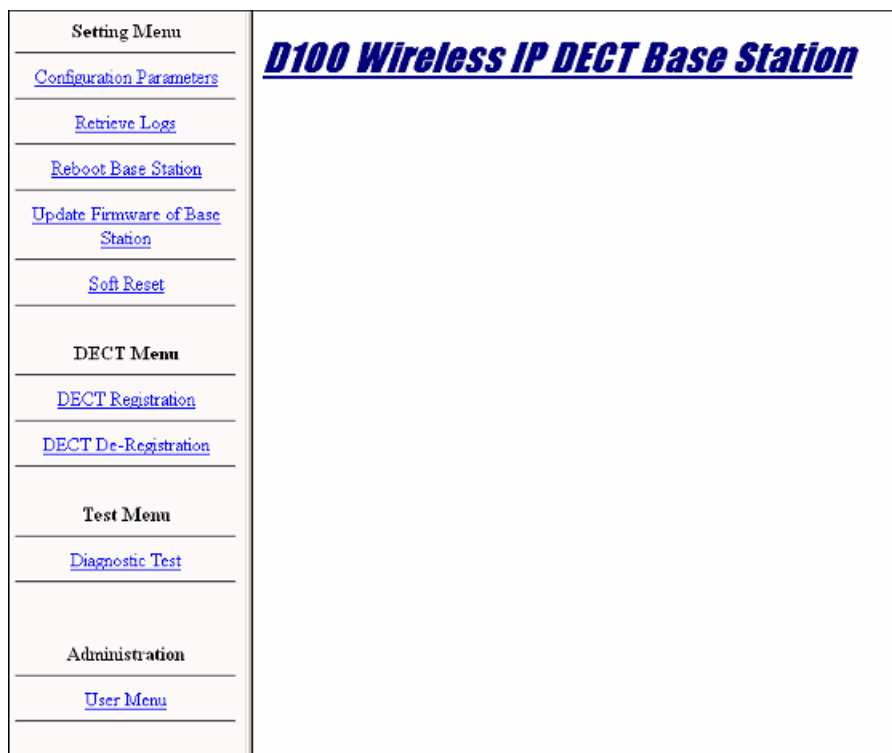

The Base Station Web Management Interface is a webpage that provides access to various management functions on the D100, including configurations, logging information, rebooting, and updating firmware.

You must be an administrator in order to view and utilize the Base Station Web Management Interface due to the sensitivity of the information contained within. Note that rebooting the base station overwrites the changes made to the configuration parameters using the Base Station Web Management Interface.

To access the Base Station Web Management Interface, enter the IP address of the base station into a web browser connected to the same network as the D100.

Despite the functionality of the Base Station Web Management Interface, the application does not provide as many configuration options as IP Office Manager, which is used for the majority of device configurations. While the functionality of the Base Station Web Management Interface is similar to IP Office Manager, you should use the interface solely as a tool for retrieving critical and system logs.

A limit of five administrators can access the Base Station Web Management Interface. You can edit the list of administrators by selecting the **User Menu** link in the left frame of the interface to open a page that contains the configurable user list table. Click **Update** when you are satisfied with any changes you make to the user list table.

The login screen requests user credentials. By default, the credentials are:

- **Username:** d100
- **Password:** d100

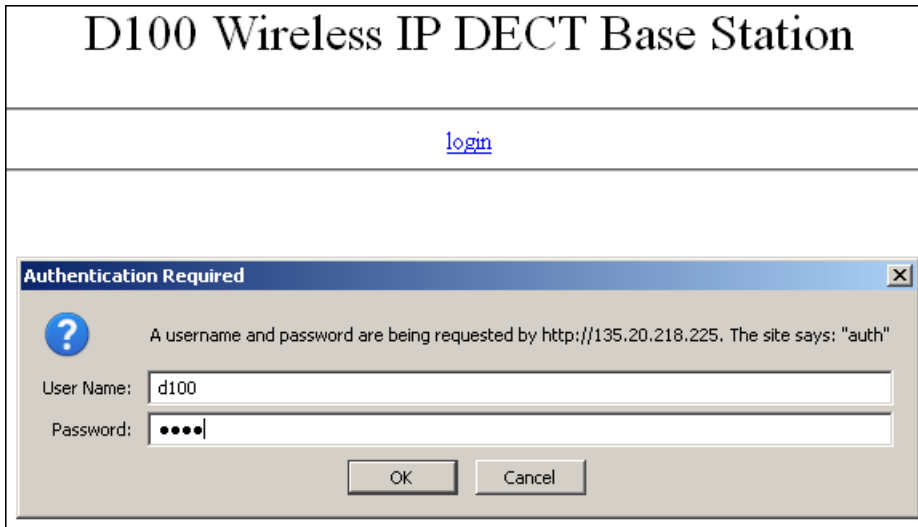

Related topics:

[Obtaining log information](#) on page 72

[Rebooting the base station](#) on page 74

Obtaining log information

As mentioned previously, the D100 base station can save log information that you can view using the Base Station Web Management Interface. If the IP Office and the base station are in a location that is remote from the administrator, then you must access the web interface using a secure VPN tunnel. For more information, see [Using SSL VPN](#) on page 74.

To enter the log interface, click **Retrieve Logs** on the left frame of the Base Station Web Management Interface. Using the log interface, you can set parameters, download logs, delete logs, and view statistical information.

Setting log parameters

You can configure two types of logs: critical logs and system logs.

- **Critical log** (Critical.log):

The Critical log saves Reboot and Firmware update events. The size of the Critical.log file is greater than 300Kb and you can save more than 600 events.

- **System log** (System.log):

According to the System.log parameter for Log Level, and whether or not saving the log is enabled, you can save all kinds of system log information, such as network, SIP, RF, etc. The size of the System.log file is approximately 1Mb.

The Log Level determines the corresponding system log parameters as follows:

- Level 1: INFO log saved.
- Level 2: INFO and ERROR logs are saved (Default).
- Level 3: INFO, ERROR and WARNING logs are saved. Set this level for heavy testing and RF-related problems.
- Level 4: INFO, ERROR and WARNING and DEBUG logs are saved. Set this level for system and SIP-related problems.
- Level 5: INFO, ERROR, WARNING, DEBUG and TRACE logs are saved.

Downloading statistical information

You can download statistical information using the **Statistic Information** link. Clicking on the link downloads the StatisticInformation.log file that contains the parameters listed in the table found under [Statistics information](#) on page 69.

Related topics:

[Using SSL VPN](#) on page 74

Using SSL VPN

In some network deployment scenarios, the IP Office and the base station are located remotely from the administrator. In this case, an administrator can obtain base station logs using a Secure Sockets Layer Virtual Private Network (SSL VPN) to remotely access IP Office and LAN devices.

For information on configuring a SSL VPN tunnel, see the [IP Office SSL VPN Solutions Guide](#).

In addition to setting up a SSL VPN, you must use the following procedure to configure Network Address and Port Translation (NAPT) rules for each VPN tunnel using IP Office Manager. Note that each base station receives an entry in the NAPT table.

Procedure

1. In the IP Office Manager navigation list, select **Service**.
2. In the **Service** list, select the SSL VPN service where you want to configure NAPT rules.
3. In the details pane for the service, select the **NAPT** tab.
4. Under **Application**, open the drop down list and select **Custom**.
The **Protocol** and **Internal Port Number** fields are automatically filled with the default values.
5. Modify the **External Port Number** field.
6. Repeat steps 4 and 5 to configure rules for additional base stations.
7. **(Optional)** To delete an NAPT rule, use the empty column on the left side of the table. Right-click in the empty cell next to the rule you want to delete and select the **Delete** option.

Next steps

Access each base station remotely using the VPN tunnel IP address and the external port number configured in the NAPT rules table in IP Office Manager. The VPN tunnel address must include the external port in the format:

```
http://<tunnel IP address>:<external port>
```

Log in to each base station and retrieve logs using the method described in [Obtaining log information](#) on page 72.

Rebooting the base station

You can reboot the base station using the Base Station Web Management Interface such that the base station reboots either normally or into Maintenance Mode.

The **Reboot Base Station** option is available under the **Setting Menu** in the left navigational pane.

After rebooting the base station, the base station reverts to factory default settings. Rebooting the base station clears the following parameters from the base station:

- Configuration file information (D100.cfg, D100settings.txt, D100prov.txt, Language file)
- User login information
- Log (System log)
- Local directory
- Call log

Updating base station firmware

IP Office automatically updates the D100 base station firmware, but only if IP Office Manager is configured such that the system's memory card is the source for the files used by the D100.

In IP Office Manager, navigate to the **System > System** tab and ensure that the **Phone File Server Type** is set to **Memory Card**, as the following image demonstrates.

The screenshot shows the IP Office Manager configuration interface. At the top, there are tabs for 'WCM' and 'CCR'. Below these are several sub-tabs: 'System', 'LAN1', 'LAN2', 'DNS', 'Voicemail', 'Telephony', 'Directory Services', and 'System E'. The 'System' tab is selected. The main content area shows a 'Name' field with the value '00E0070521A3'. Below this is a 'Contact Information' section with a text box containing the instruction 'Set contact information to place System under special control'. Further down, there are several configuration fields: 'TFTP Server IP Address' (0 . 0 . 0 . 0), 'HTTP Server IP Address' (0 . 0 . 0 . 0), 'Phone File Server Type' (a dropdown menu set to 'Memory Card'), 'Manager PC IP Address' (0 . 0 . 0 . 0), and 'Avaya HTTP Clients Only' (an unchecked checkbox).

Once the correct **Phone File Server Type** is set, IP Office can automatically upgrade the base station firmware when IP Office reboots. The firmware downgrade procedure uses the same method and requires the same configuration in IP Office Manager.

Updating handset firmware

To update the D160 handset firmware, you must install Microsoft .NET version 4 and you must use the D160 Upgrade Jig.

To check your version of Microsoft .NET, click **Control Panel > Add or Remove Programs**. If you do not have Microsoft .NET version 4, download it directly from Microsoft at:

<http://www.microsoft.com/en-us/download/search.aspx?q=.net%204.0%20>

If you update the handset firmware on a live system, you must reboot the base station to which the handset registers once the update completes.

Before you begin

Ensure that the handset battery has enough power to last the duration of the upgrade, which might be a few minutes. Also, ensure that you have the latest USB-UART driver installed for the Upgrade Jig (CDM 2.04.06 WHQL Certified), which is also required. Locate the available Upgrade Jig drivers for each operating system in the **Upgrade Jig Drivers** folder.

Note that the following procedure has been tested and successfully performed on Windows XP and Windows 7.

Procedure

1. Connect the Upgrade Jig to the PC through an available USB port.
2. Extract the D160 Firmware Upgrade file to anywhere on your PC.
3. In the extracted folder, run the **D160 Handset Writer** application. The D160 Handset Writer window appears:

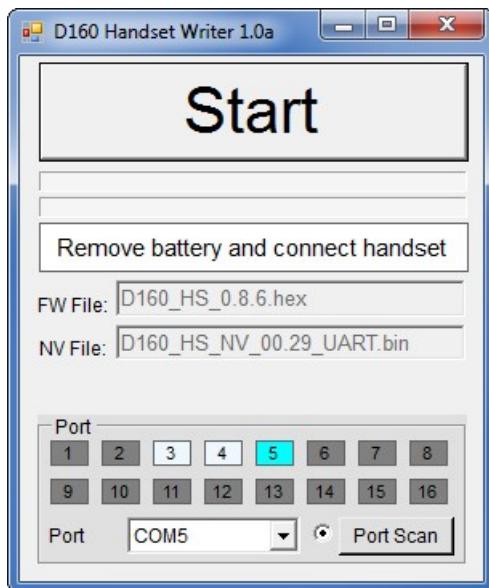

Identify the status display in the D160 Handset Writer.

4. In the D160 Handset Writer, click the **Port Scan** button to populate the list of newly available ports.
The Writer application highlights and selects the port number allocated in the Upgrade Jig.
5. Connect the Upgrade Jig to the handset using the headset jack and remove the battery from the handset.
6. Click the **Start** button on the Writer application, then reinstall the battery.
The writing begins. The writing process should take less than a minute to complete.

If the handset was not detected by the application, the status display reads **Handset not detected**.

7. If successful, the status display reads **Update complete**.
If unsuccessful, the status display reads **Update failed**. If the update fails:
 - Check the connection between the Upgrade Jig and the handset.
 - Ensure that the handset has a fully-charged and compatible battery.
-

Chapter 7: Factory settings

The following table lists the default factory settings for the D160 handset and the D100 base station. You can use multiple methods to reset the base station to factory default, but the preferred method is to use IP Office System Status Application. To determine the appropriate method to use in your situation, see [Resetting the base station to factory default](#) on page 80.

Item	Handset	Base station
Ringer Tone	Tone A	n/a
Ringer Volume	High	n/a
Ringer Mute	Off	n/a
Ear Speaker Volume	4	n/a
Hands Free Volume	4	n/a
Headset Volume	4	n/a
Range Alarm	On	n/a
DHCP	n/a	Enable
IP Address	n/a	192.168.1.100
Subnet Mask	n/a	255.255.0.0
Default Gateway	n/a	192.168.1.1
SIP Controller	n/a	192.168.1.1
Ping Reply	n/a	Enable
Destination Unreachable	n/a	Enable
DECT PIN ID	n/a	3100
Administrator Password	n/a	7828876
Login ID for the Base Station Web Management Interface	n/a	d100
Login Password for the Base Station Web Management Interface	n/a	d100
System Log Level	n/a	Level 2
Base DTMF Dial Output Time	n/a	100ms  Note: Continuous DTMF signaling is not available.

Resetting the base station to factory default

You can use multiple methods to reset the base station parameters to factory default. The methods that follow are listed by order of preference. Read the methods and select the first that applies to you.

- **Preferred method:** Use System Status Application to reset the base station.
- **Alternative method:** If you cannot see the base station in System Status Application, use the Base Station Web Management Interface.
- **Ultior method:** If the preferred and alternative methods do not apply to your situation, see [Resetting the base station using the base station](#) on page 81.

Related topics:

[Resetting the base station using System Status Application](#) on page 80

[Resetting the base station using the Base Station Web Management Interface](#) on page 81

[Resetting the base station using the base station](#) on page 81

Resetting the base station using System Status Application

Using System Status Application is the preferred method for resetting the base station to factory default. Attempt the procedure below before you attempt any other factory reset method.

Procedure

1. Run System Status Application, navigate to **System > SIP DECT Base Station** and select the base station you want to reset.
 2. On the status page that appears, highlight the desired base station.
 3. Click the **Reset Base To Default** button on the bottom of the status page. The base station resets to factory default.
-

Resetting the base station using the Base Station Web Management Interface

Using the Base Station Web Management Interface to reset the base station to factory default is an alternative method that you should only attempt when System Status Application fails, or if the base station does not appear in System Status Application at all.

For more information, refer to [Base Station Web Management Interface](#) on page 71.

If this alternative method also fails, only then should you attempt the ulterior method described in [Resetting the base station using the base station](#) on page 81.

Procedure

1. In the Base Station Web Management Interface, navigate to the **Setting Menu** in the left navigational pane.
 2. Select **Reboot Base Station**.
 3. Select **Execute (Factory Initialize)**.
The base station resets to factory default.
-

Resetting the base station using the base station

Only use this method to reset the base station to factory default when the preferred and alternative methods fail. See [Resetting the base station using System Status Application](#) on page 80 before you attempt the following method.

Procedure

1. Press and hold the **Registration** button located on the front of the base station and insert a pin into the **Reset button hole** also located on the front of the base station. Hold both buttons for five seconds.
The base station resets the following parameters to the default values indicated:
 - **IP Address:** 192.168.1.100
 - **Subnet Mask:** 255.255.0
 - **Default Gateway:** 192.168.1.1
 2. You can now use the Base Station Web Management Interface to reset the base station. See [Resetting the base station using the Base Station Web Management Interface](#) on page 81.
-

Factory settings

Chapter 8: Accessories

Uniden provides accessories for the Avaya D100 at <http://www.uniden.com/> via the “Accessories” page. You can use the “Refine by” navigation pane on the left side of the screen and select “Avaya” to list all Avaya accessories available through Uniden. You can also enter “Avaya D100” in the search field at the top of the page to list accessories specific to the D100 SIP Wireless Terminal.

The D100 accessories available include batteries, headsets, protective covers, and replacement parts.

Chapter 9: Troubleshooting

Changed IP parameters and lost connectivity to the base station

If you changed IP parameters and lost connectivity to the base station you may have entered invalid values for the IP parameters.

Reset the base station to the factory defaults and follow the base station installation procedure appropriate to your IP Office deployment scenario.

Configuring parameters using the Base Station Web Management Interface

You can configure the following parameters using the Base Station Web Management Interface. If necessary, obtain the base station IP address using the handset menu.

Parameter	Description	Default value
DHCP setting	DHCP On/Off	On
MAC address	The MAC address of the base station. The MAC address parameter is read-only.	The MAC address of the network interface.
IP address	The IP address of the base station. If DHCP is disabled, you can change the IP address.	192.168.1.100
Subnet mask	The subnet mask. If DHCP is disabled, you can change the subnet mask.	255.255. 0.0
Default gateway	The IP address of the default gateway. If DHCP is disabled, you can change the default gateway IP address.	192.168.1.1
SIP server	The IP address of the SIP server. If DHCP is disabled, you can change the SIP server IP address.	192.168.1.1

Handset display reads “Duplicate IP Address”

The handset display reads **Duplicate IP Address** when the base station detects duplicate addresses in the subnet. Verify your IP settings.

Handset display reads “No Service”

If the handset display reads **No Service** then the base station has lost connectivity to IP Office. Navigate the **Administrator Setting** menu to view error information and attempt to resolve the error using the information in the following table.

For more information, see [Error information](#) on page 63.

Error message	Resolution
No Configuration Server	The base station could not retrieve configuration data from IP Office. Verify the IP connectivity.
No Connection	Verify the IP connectivity.
Not Configured	The base station is not configured on IP Office. Verify the configuration in IP Office Manager. Specifically, check that the base station's MAC Address is configured correctly.
Wrong Market	The IP Office system companding law does not match the market for the base station. If the IP Office system operating mode uses companding law of mu-law and market=Global, it is a match. If the IP Office system operating mode uses companding law of a-law and the market=EU, it is a match. Any other configuration is a mismatch.

Handset display reads “Searching”

The handset display reads **Searching** when you are outside the range of the base station or when the base station is out of service.

Handset not recognized by the upgrade firmware

If the handset upgrade firmware does not recognize the handset when connected to the upgrade jig, the connection might be experiencing some disruption. Ensure proper contact between the upgrade jig and the headset jack by disconnecting and reconnecting the upgrade jig several times and rotating the plug back and forth when it is inserted into the headset jack.

Maintenance Mode

Administrators can use Maintenance Mode to maintain the base station using the following software applications found in the Base Station Web Management Interface:

- Real Time OS
- Network Stack (TCP/IP)
- Web Server

During Maintenance Mode, the RF software component does not launch, and the base station does not connect to the handsets. Also, the power and status LEDs are turned on. During Maintenance Mode, the base station uses the last IP address used.

You can use one of the following methods to enter Maintenance Mode. Use the method that works best for your installation:

1. While the base station is running, press and hold the **Reset** button on the front of the base station for five seconds. After a short while, the base station automatically begins to reboot.
2. Plug the Ethernet cable into the base station while pressing the **Reset** button.
3. Use the Base Station Web Management Interface to reboot the D100 to factory default. See [Rebooting the base station](#) on page 74.

In Maintenance Mode, you can access most of the areas available in the Base Station Web Management Interface, including configuration parameters, log information, base station reboot, firmware update, and diagnostics. For more information, see [Base Station Web Management Interface](#) on page 71.

The following scenarios illustrate typical uses for Maintenance Mode.

Scenario 1: Corrupted firmware

If the base station firmware is corrupt, the base station starts in Maintenance Mode and then automatically requests a firmware update, which is stored in IP Office. After updating, the base station reboots.

If the firmware cannot update, for example there is no firmware in IP Office, the base station starts in Maintenance Mode, and only an administrator can upload the correct firmware onto

IP Office and perform an update manually using the Base Station Web Management Interface. For more information, see [Updating base station firmware](#) on page 75.

Scenario 2: Bad firmware, but not corrupted

If the base station firmware is not corrupt, for example the CRC check passes successfully, but the device still does not work correctly, the base station will not detect the problem by itself. In this case, only an administrator can update the firmware in one of the following ways:

- If a handset can connect with the base station and the handset menu is operable, update the base station using the handset. See [Check firmware update](#) on page 63.
- If the Base Station Web Management Interface is operable while the firmware is running, use the **Firmware Update** button to update the base station. See [Updating base station firmware](#) on page 75.

Repeater registration failure

If you experience failure while attempting to register a repeater, check the IP Office environment for other DECT equipment with registration enabled as this could be causing the interference.

Test the registration by turning off the base station to which the repeater is registered and watch to see if the LED on the repeater changes from solid to a slow flash. A slow flash indicates that the base station is either not detected or out of range.

Unknown DECT PIN

If the base station has an unknown DECT PIN, you can change it by navigating to the **Configuration > Administrator Settings** menu on any handset that is registered to the base station.

If there are no registered handsets, you must reset the D100 base station to the factory default, thereby returning the DECT PIN to **3 1 0 0**. See [Resetting the base station to factory default](#) on page 80.

Unknown IP address

If the D100 base station has an unknown IP address and cannot connect to IP Office, you can locate or change the address by performing the following procedure.

- On a registered handset, navigate to the **Configuration > Network** menu and view or change the D100 base station IP address.

Index

A

accessories	83
administrator	60 , 61
password	60 , 61
settings	60

B

base station	12 , 22 , 26 , 36 , 37 , 40 , 42 , 80
configuration	26
configure	22
installation	36 , 37
scenarios	37
mounting	40
reset	80
base station survey	36
Base Station Web Management Interface	26 , 72 , 81 , 86
base unit	7
battery	15 , 43
boot up sequence	42
booting up	42

C

capacity	9
charge unit	14
clear slot survey	35
codec	9
configuration	19 , 26 , 86
base station	26
IP Office	19
configure	22 , 23 , 25
base station	22
extension	23
static IP parameters	25
connecting	15

D

D100.cfg	42
D100prov.txt	42
D100settings.txt	42
DECT PIN	61
DECT RF	43
registration	43

default	75
default gateway	67
deployment	35 , 36
deregister	44
handset	44
destination unreachable	68
DHCP	20 , 42 , 66
setting	66
DHCP	66
diagnostics	62
DoS attack protection	9

E

error information	64
ethernet	9
Ethernet	69
extension	23
configure	23

F

factory default	80
factory settings	79
features	9
firmware	63 , 75
update	63 , 75
check	63
update	63
firmware	63
floor plan	31

H

handset	7 , 9 , 13 , 43 , 44 , 76
deregister	44
firmware	76
register	43
headset	15

I

icons	15
installation	50
IP address	65
IP Office	7 , 9 , 19

configuration	19	power up	42, 43
<hr/>		<hr/>	
L		R	
language	9	reboot	75
LCD	15	register	43
LED	15	handset	43
log information	73	registration failure	88
<hr/>		repeater	14, 48–50
M		installation	48
MAC address	65	registration	48
maintenance mode	75, 87	reset	63, 80
Microsoft .NET	76	base station	63, 80
mounting	40, 50	reset	63
base station	40	reset button	12
<hr/>		ROM	42
N		<hr/>	
network	9, 64	S	
<hr/>		settings	60
O		administrator	60
option 60	42	signal strength	46
option 66	42	survey	46
out of range	53	SIP controller	67
overview	7	site planning	30
<hr/>		SSA	57
P		SSL VPN	74
password	60, 61	static addressing	20
administrator	60, 61	static IP parameters	25
performance	9	configure	25
ping reply	68	statistics	69
PoE	42	subnet mask	66
power down	43	System Status Application	57
Power over Ethernet	42	<hr/>	
<hr/>		T	
		telephony	9
		<hr/>	
		U	
		update	75
		firmware	75
		Upgrade Jig	15, 76
		<hr/>	
		V	
		vendor	83