

MINOLTA DiIMAGE SCAN Elite 5400

(2890)A 1
(2890-100)

CODE



- Scanner Type** 35mm film scanner, moving film type
- Usable Film Type** 35mm film (Color / B&W, negative/positive)
- Scanning Dimension** 35mm film: 24.61 x 36.69 mm / 5,232 x 7,800pixels
- Optical Resolution** 5400dpi
- Scanning method** Fixed sensor, moving film, single-pass scan
- Image Sensor** 3-line CCD with 5,300 pixels per line, RGB primary color filter

Scan Time (excluding the data transfer time to PC)

- Times listed above do not include data transfer time to the computer.
- Scan time varies with the film images and the scanner preferences and functions used.
- Scan time can be longer for negative film than positive film.
- Approximate time with 5400 dpi (maximum optical resolution), 8-bit color depth,
- No cropping, No auto exposure, No color matching, No Digital ICE processing, No image corrections, No Grain Dissolver, No Multi-sample scanning

Setting / Mode	Scan time (Approx.)		
	Windows		Macintosh
	USB2.0	IEEE1394	FireWire
Index scan	15 sec.	15 sec.	16 sec.
Prescan	10 sec.	10 sec.	12 sec.
Scan	60 sec.	68 sec.	69 sec.

Measuring condition

	Windows	Macintosh
CPU	Pentium 4/ 2.53GHz	PowerPC G4
OS	Windows XP Professional	Mac OS X 10.2.1
RAM	1GB	1GB
Hard-disk space	60.9GB	70.72GB
Interface	USB2.0 built-in	FireWire built-in
	IEEE 1394 Melco IFC-ILP4	
Application	Photoshop 7.0.1	Photoshop 7.0.1
Memory allocated to application	80%	739MB

2 (2889)A

CODE

AD Conversion	16bit (per color channel)
Output	8/ 16bit (per color channel)
Dynamic Range	3.8 (Tested value)
Light Source	3-wavelength cold-cathode fluorescent lamp (Not user-replaceable)
Focus	Auto focus (Point AF available) Manual focus (driver software/manual focus dial)
Others	Grain Dissolver, Auto Dust Brush, Digital ICE, Pixel Polish, Quick scan button
Interface	IEEE1394 (FireWire)(One 6-pin receptacle connector) USB 2.0 (Type-B connector), Compatible with USB1.1
Power Requirements	
Scanner	24V DC / 0.84A
AC Adapter	Input: 100- 120 / 200 - 240V AC, 50/60Hz Output: 24V DC / 0.84A
Power Consumption	Maximum 30W
Size	65mm (W) x 165mm (H) x 360mm (D)
Weight	Approx. 2.5kg
Standard Accessory	
	35mm Film Holder FH-M10 <7890-240> Slide Mount Holder SH-M10 <7890-241> USB Cable UC-2 <7889-810> IEEE1394 Cable FC-2 <7890-810> Stand ST-M10 <7890-340> Tool set RT-M10 <7890-341> DiMAGE Scan <7310-002> Photoshop Elements 2.0 <8700-532> (E/F/G/S/I) Photoshop Elements 2.0 <8700-533> (Japanese)
AC Adapter	AC-U22 <8700-715> (ME, MS) 200-240V AC, 50Hz for continental Europe, Oceania, and Asia (except for Taiwan, Japan, Hong Kong, and China) AC-U23 <8700-716> (ME/MGB, MK) 200-240V AC, 50Hz for England, Hong Kong, and China AC-U24 <8700-717> (SMO) 200-240V AC, 50Hz for China. AC-U25 <8700-718> (MC, MCI, MK, MSJ) 120V AC, 50/60Hz for North America, Taiwan, and Japan
Operating Environment	Temperature 10 to 35 degreesC, Humidity 15 - 85 %RH non-condensing
Storage Environment	Temperature -20 to 60 degreesC, Humidity 15 - 85 %RH non-condensing

System Requirements

	IBM PC/AT compatible computers	Macintosh computers
CPU(*1)	Pentium 166MHz or later processor	
OS	USB: Windows98, 98 Second Edition, Me, 2000 Professional, or XP Professional IEEE1394: Windows Me, 2000 Professional, or XP Professional	USB: Mac OS 8.6 to 9.2.2, Mac OS X v10.1.3 to v10.1.5, and v10.2.1 to 10.2.3 FireWire: Mac OS 8.6 (*2) to 9.2.2, Mac OS X v10.2.1 to 10.2.3
RAM(*1)	128MB of RAM or more	128MB of RAM or more in addition to the requirements for the Mac OS and applications
Hard-disk space(*1)	600MB or more	
Monitor	1024x768 or greater is recommended. A monitor with 640x480 pixels can be used.	
	A 16-bit or greater	32,000 colors or more
Application	Adobe Photoshop 5.5, 6.0.1, 7.0, Adobe Photoshop Elements, P&A Paint Shop Pro 7.0, Corel PHOTO-PAINT 10.0	The plug-in driver software has been tested or use with Photoshop 5.5, 6.0.1, 7.0, and Photoshop Elements.
Interface	USB port as standard interface, Adaptec: USB2connect 3100, USB2connect 5100, DuoConnect. Belkin: Hi-speed USB 2.0 5-Port PCI Card, USB 2.0 Hi-Speed 2-Port PCI Card	Standard USB port supplied by Apple Computer.
Application	The plug-in driver software has been tested or use with Adobe Photoshop 6.0.1, 7.0.1, Adobe Photoshop Elements 2.0, P&A Paint Shop Pro 7.0, Corel PHOTO-PAINT 11.0	The plug-in driver software has been tested or use with Photoshop 6.0.1, 7.0.1, and Photoshop Elements 2.0.

*1: See below for use of CPU, RAM, hard-disk space requirements with 16-bit color depth, Pixel Polish :ON.

*2: FireWire 2.32 to 2.3.3 is necessary for use on Mac OS 8.6.

System Requirements with 16-bit color depth / Pixel Polish**Windows**

	16-bit color depth	8-bit, Pixel Polish: ON
CPU	Pentium II (Pentium 166MHz) or later processor	Pentium III (Pentium 166MHz) or later processor
RAM	256MB (128MB)	512MB (256MB)
Hard-disk space	2GB (1.2GMB)	2GB (1.2GB)

System Requirements with 16-bit color depth / Pixel Polish**Macintosh computers**

	16-bit color depth	8-bit, Pixel Polish: ON
CPU	PowerPC G4 (PowerPC G3) or later processor	PowerPC G4 (PowerPC G4) or later processor
RAM	256MB (128MB) of RAM in addition to the requirements for the Mac OS and applications	
Hard-disk space	2GB (1.2GMB)	

To use the plug-in with Photoshop or Photoshop Elements on Mac OS 8.6 to 9.2.2, add the above memory requirements to Photoshop's suggested application memory allocation.

How to use a Parts List.

Product code and product name are shown on each page. You can close them by clicking the "[-]" on the left,if not necessary.
 Parts list: Clicking [+] of bookmark displays the subordinate headings and clicking the number jumps to each page.

Blue for new parts No.by additional parts.

Red line for discontinued parts.

Illustration: Clicking the parts number "/□" displays related PML.

Right page: * for amendments.

PML: Clicking the page number "/□" displays related illustration page. Clicking [+] of bookmark displays the subordinate headings and clicking number jumps to each page. (PML amendment advices)

About the written contents of a parts list.

Actual construction or shape of the parts may not be identical to the drawing in this Parts List.

Those parts are still applicable unless otherwise specified by a Parts Modification List.

The Parts Modification List will be issued if a modification causes incompatibility with original parts, or results in greatly different parts from the original in shape or construction.

About the written contents of a PARTS MODIFICATION LIST.

Description for each item in PML.

(1) Code number of the model and page number.

(2) Reference No..

(3) Relevant page of Parts List.

(4) Reference No. of its creation post is shown.

(5) Number of relevant Supplementary Information if any.

(6) Reason of modification.

(7) Models in which the part is used in common.

(8) Previous parts number.

(9) New parts number.

(10) The part marked as "~~Previous~~" is no longer available as a service part. Use new Part.

(11) Arrow (→, ←) show parts interchangeability.

→ ○ (×) : Previous part can be (cannot be) replaced with new part.

× (○) ← : New part cannot be (can be) replaced with previous part.

(12) Name of the newly added part. See Parts List for the name of current Parts.

(13) Description of the modification.

(14) When the part cannot be replaced as a single one, vertical colum shows the related parts to be replaced as a set.

Arrows (→, ←) at base of table show interchangeability or parts as a set.

(15) Continued on the next page.

Ex.

<p>(1234)A 1 (1)</p> <p>PARTS MODIFICATION LIST</p>													
<p>(2)</p> <table border="1" style="width: 100%; border-collapse: collapse;"> <tr> <td style="width: 50%;">管理No. REF No.</td> <td style="width: 50%;">QS FA 1234-P001</td> </tr> <tr> <td>主管部署 Divison</td> <td>カメラCS部 Camera CS Division</td> </tr> <tr> <td>施行年月日 Valid from</td> <td>August 1,2003</td> </tr> </table>	管理No. REF No.	QS FA 1234-P001	主管部署 Divison	カメラCS部 Camera CS Division	施行年月日 Valid from	August 1,2003	<table border="1" style="width: 100%; border-collapse: collapse;"> <tr> <td style="width: 33%;">Approved by 承認</td> <td style="width: 33%;">Verified by 審査</td> <td style="width: 33%;">Written by 作成</td> </tr> <tr> <td style="height: 40px;"></td> <td></td> <td></td> </tr> </table>	Approved by 承認	Verified by 審査	Written by 作成			
管理No. REF No.	QS FA 1234-P001												
主管部署 Divison	カメラCS部 Camera CS Division												
施行年月日 Valid from	August 1,2003												
Approved by 承認	Verified by 審査	Written by 作成											
<p>(3) Parts List P.1</p>	<p>(4) ***** SUPPLEMENTARY INFORMATION No. QS FA 1234-S01E</p>	<p>(5)</p>											
<table border="1" style="width: 100%; border-collapse: collapse;"> <tr> <td style="width: 20%;">変更理由 REASON</td> <td style="width: 40%;">(6)</td> <td style="width: 20%;">共通機種 COMMON MODEL</td> <td style="width: 20%;">(7)</td> </tr> <tr> <td>Previous</td> <td>(8)</td> <td>→○(×) (○)×←</td> <td>(9)</td> </tr> </table>	変更理由 REASON	(6)	共通機種 COMMON MODEL	(7)	Previous	(8)	→○(×) (○)×←	(9)	<p>(10)</p> <p style="text-align: center;">(11)</p> <p style="text-align: center;">(12) Addeid./新設 1234-5678-90 (Parts No.) ABC ASSY (Part name) ABC セット(部品名称)</p>	<p>(13)</p>			
変更理由 REASON	(6)	共通機種 COMMON MODEL	(7)										
Previous	(8)	→○(×) (○)×←	(9)										
<p>(14) セットでの互換性/ Interchangeability as a set. Previous →○(×) (○)×← New</p>													
<p>(15) Continued on the next page./次ページにつづく</p>													



INDEX

PART NO.	PAGE	PART NO.	PAGE
2890-0110	2	2890-9001	1
2890-0111	1	2890-9002	1
2890-0187	1	2890-9003	2
2890-0401	2	2890-9004	2
2890-0402	2	2890-9005	2
2890-0626	1	2890-9006	2
2890-0037	1	2890-9007	2
2890-1002	1	2890-9101	2
2890-1003	2	2890-9102	2
2890-1004	1		
2890-1005	1	9384-2191-00.....	1,2
2890-1006	1	9384-2191-01.....	1
2890-1007	1	9384-2792-00.....	1,2
2890-1008	1	2890-0065	3
2890-1009	1	2890-0091	4
2890-1102	2		
2890-1201	1		
2890-1301	1		
2890-1302	1		
2890-1303	1		
2890-0188	1		
2890-4001	2		
2890-4002	1		
2890-4003	1		
2890-4004	2		
2890-4005	2		
2890-4006	2		
2890-4007	1		
2890-4101	2		
2890-4201	2		
2890-5851	1		

PARTS LIST



1(2890)A

PARTS LIST

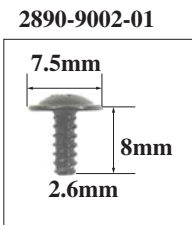
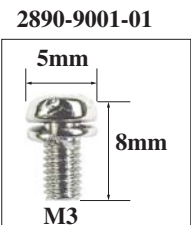
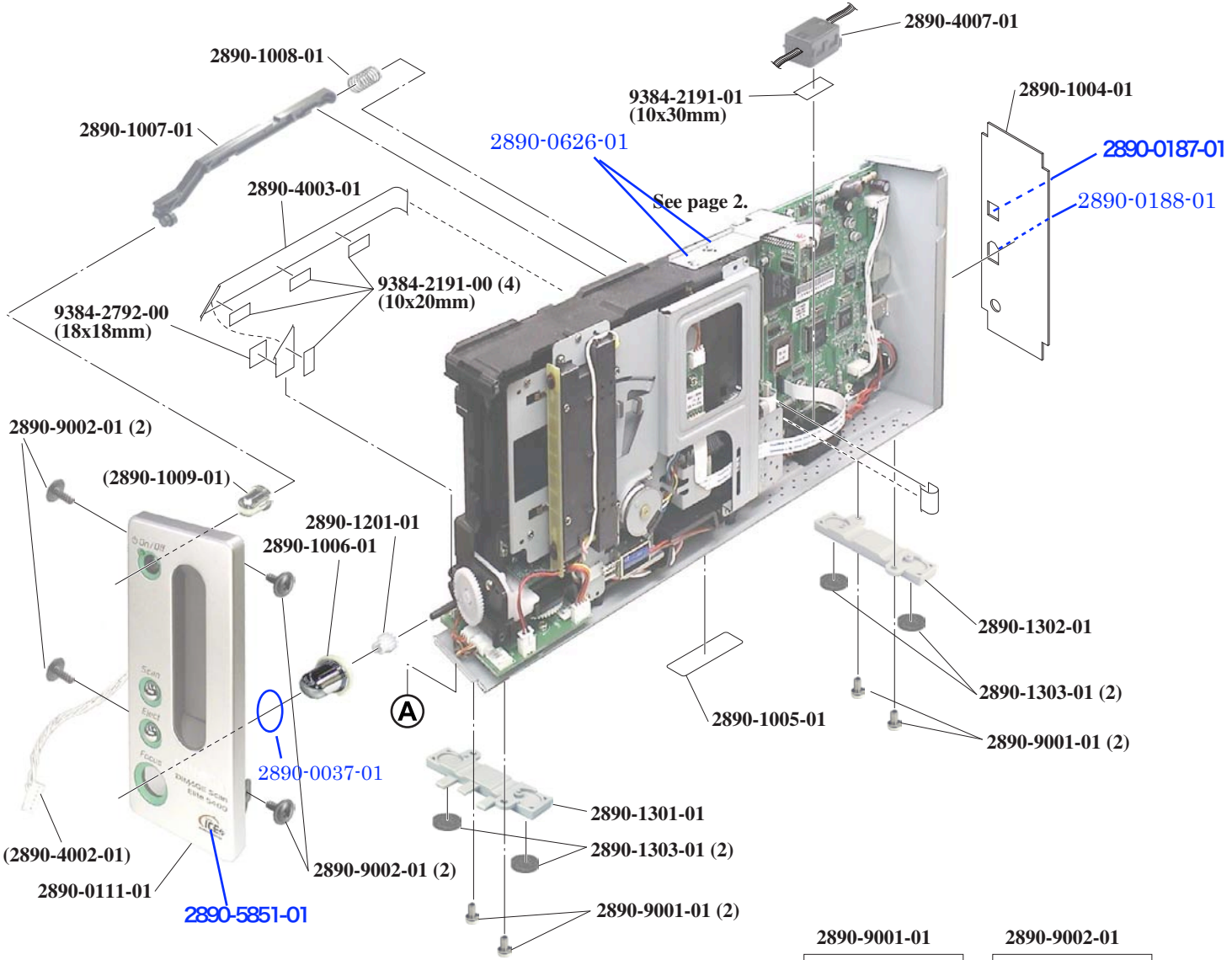
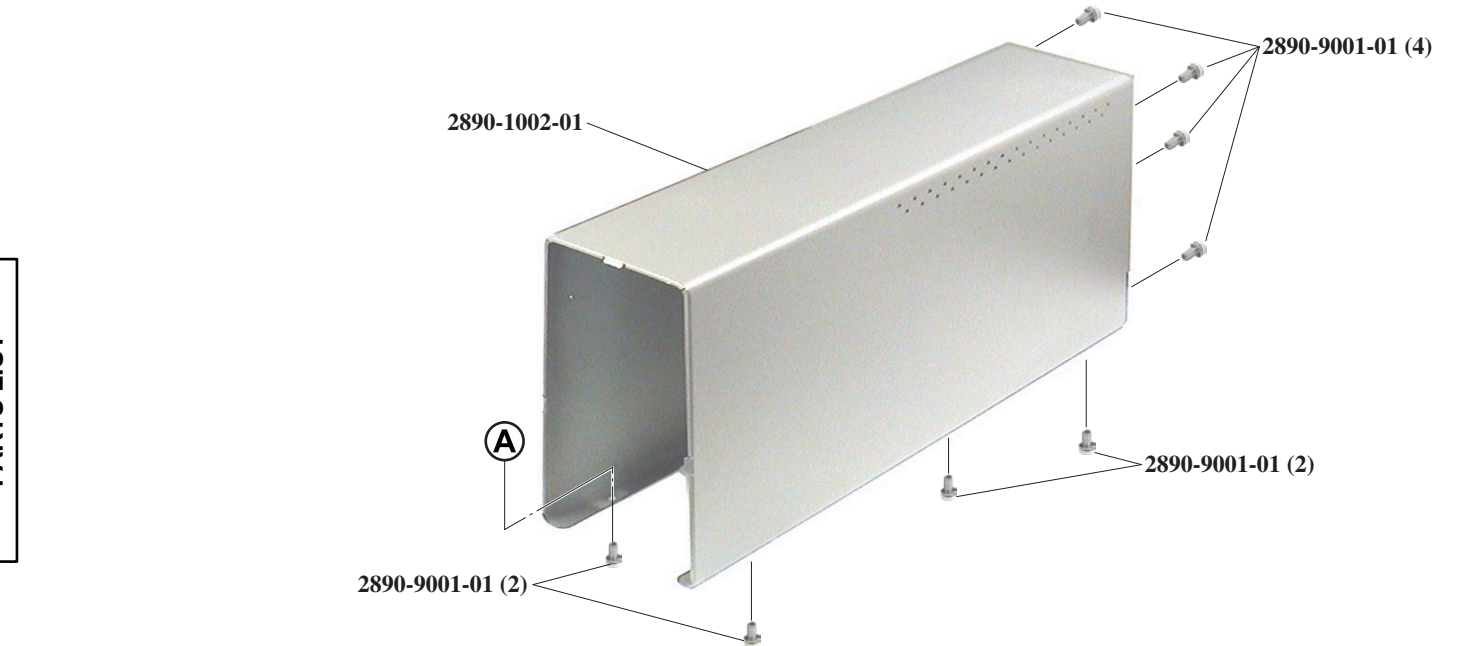

PART NO.	PART NAME		QTY.
2890-0111-01	ASSY, FRONT HOUSING	前カバーセット	1
(2890-1009-01)	POWER BUTTON	電源ボタン	1
(2890-4002-01)	CABEL 6P	ケーブル 6 P	1
2890-0187-01	USB TERMINAL COVER	U S Bターミナルカバー	1
2890-1002-01	UPPER CASE	上ケース	1
2890-1004-01	PLATE SAFETY	定格ラベル	1
2890-1005-01	SERIAL NUMBER LABEL	ボディNO. ラベル	1
2890-1006-01	FOCUS DIAL	フォーカスダイヤル	1
2890-1007-01	ARM	アーム	1
2890-1008-01	POWER SW. SP	電源SW S P	1
2890-1201-01	GEAR 12T	ギア 1 2 T	1
2890-1301-01	RUBBER HOLDER-A	ラバーホルダーA	1
2890-1302-01	RUBBER HOLDER-B	ラバーホルダーB	1
2890-1303-01	RUBBER STAND	ラバースタンド	4
2890-4003-01	FFC CABEL 18P	F F Cケーブル 1 8 P	1
2890-4007-01	COIL	コイル	1
2890-5851-01	ICE STICKER	I C Eシール	1
2890-9001-01	SCREW	ねじ	12
2890-9002-01	SCREW	ねじ	4
9384-2191-00	DOUBLE-FACED TAPE (PER ROLL)	両面テープ	4
9384-2191-01	DOUBLE-FACED TAPE (PER ROLL)	両面テープ	1
9384-2792-00	FILM TAPE-A (PER ROLL/BLACK)	フィルムテープA	1
2890-0626-01	SCREW		
2890-0037-01	WASHER		
2890-0188-01	IEEE CAP		



2(2890)A

PARTS LIST

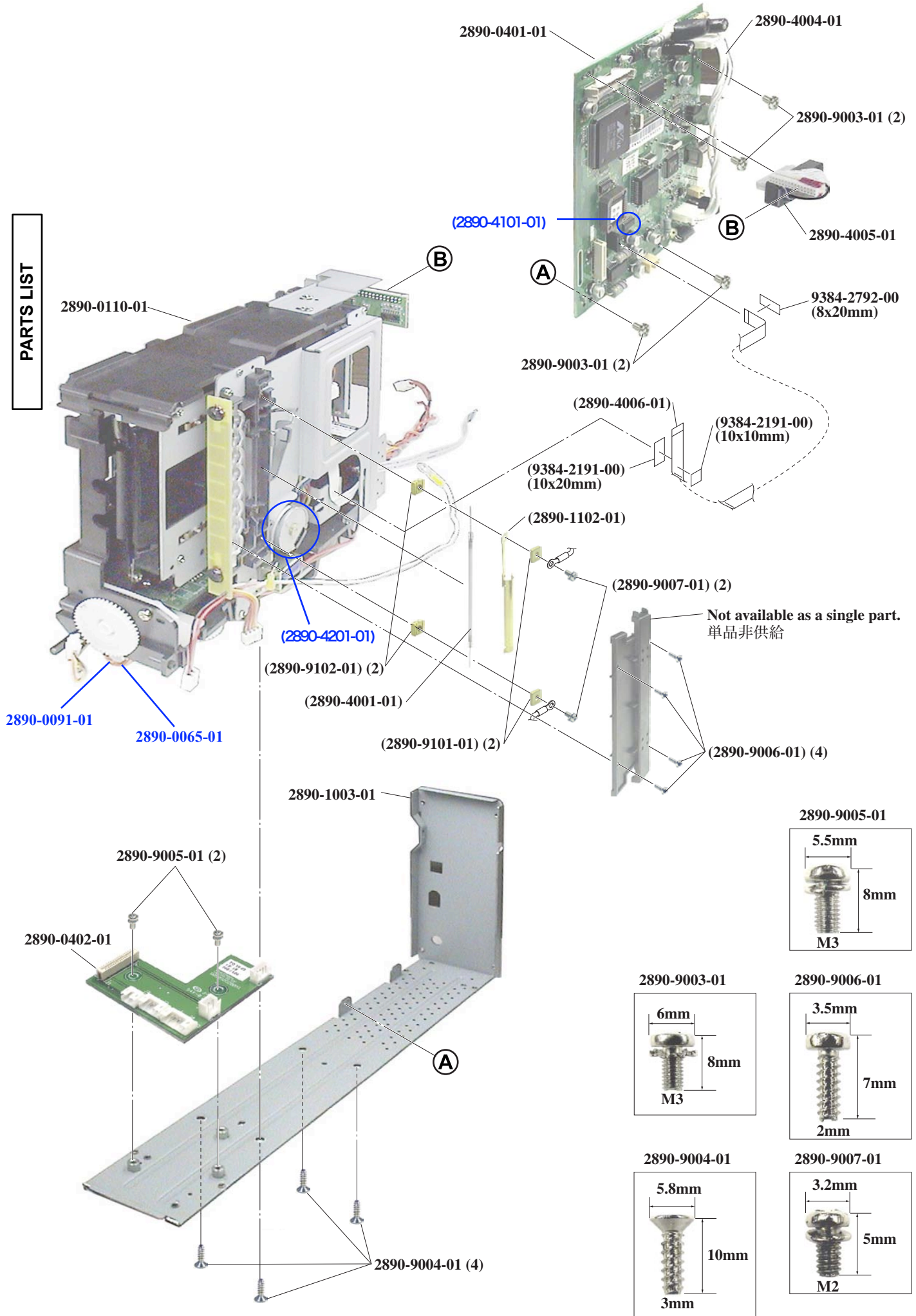



(2890)A 2

PART NO.	PART NAME		QTY.
2890-0110-01	ASSY, SCAN UNIT	撮像ユニット	1
(2890-1102-01)	REFLECTION PLATE	反射板	1
(2890-4001-01)	FLUORECSENT LIGHT	蛍光灯	1
(2890-4006-01)	FFC CABEL 8P	F F Cケーブル 8 P	1
(2890-4201-01)	MOTOR	モーター	1
(2890-9006-01)	SCREW	ねじ	4
(2890-9007-01)	SCREW	ねじ	2
(2890-9101-01)	PLATE WASHER	ワッシャ	2
(2890-9102-01)	PLATE NUT	ナット	2
(9384-2191-00)	DOUBLE-FACED TAPE (PER ROLL)	両面テープ	2
2890-0401-01	MAIN PCB ASSY	メイン基板セット	1
(2890-4101-01)	MOTOR DRIVE IC	モーター駆動 I C	1
2890-0402-01	IF16 PCB ASSY	I F 1 6 基板セット	1
2890-1003-01	LOWER CASE	下ケース	1
2890-4004-01	CABLE 4P	ケーブル 4 P	1
2890-4005-01	CABLE 30P	ケーブル 3 0 P	1
2890-9003-01	SCREW	ねじ	4
2890-9004-01	SCREW	ねじ	4
2890-9005-01	SCREW	ねじ	2
9384-2792-00	FILM TAPE-A (PER ROLL/BLACK)	フィルムテープ A	1
2890-0065-01	GEAR 24		
2890-0091-01	FOCUS MOTOR		

PARTS LIST

(2890)A 1

PARTS MODIFICATION LIST

REF No. 管理No.	QS FA 2890-P001
------------------	-----------------

Division 主管部署	DPCS Division DPCS部
Valid from 施行年月日	March 17. 2003

Approved by 承認 Tanizaki	Verified by 審査 Naruto	Written by 作成 Ueno Tozuka
-----------------------------------	---------------------------------	--

Parts List P. 2

仮-891

REASON 変更理由	サービス供給として設定する			COMMON MODEL 共通機種	2890-100
	To supply as a spare part				
Previous	2890-0110-01	---	---	2890-0110-01	New
Previous	-----	---	---	(2890-4201-01)	New



(2890-4201-01)
MOTOR
モーター
Added./ 新規手配

REF No. 管理No.	QS FA 2890-P002
------------------	-----------------

Division 主管部署	DPCS Division DPCS部
Valid from 施行年月日	March 17. 2003

Parts List P. 2

仮-891

REASON 変更理由	サービス供給として設定する			COMMON MODEL 共通機種	2890-100
	To supply as a spare part				
Previous	2890-0401-01	---	---	2890-0401-01	New
Previous	-----	---	---	(2890-4101-01)	New



(2890-4101-01)
MOTOR DRIVE IC
モーター駆動IC
Added./ 新規手配

■ 本案内状に従い、パーツリストへの転記等、メンテナンスを行なってください。

According to this list, correct "Parts List" in Service Manual for effective parts management.

KONICA MINOLTA CAMERA, INC.

PML

(2890)A 2

PARTS MODIFICATION LIST

REF No. 管理No.	QS FA 2890-P003
------------------	-----------------

Division 主管部署	CS Division CS部
Valid from 施行年月日	April 27, 2004

Approved by 承認	Verified by 審査	Written by 作成
Tanizaki	Naruto	Ueno

Parts List P. 1

仮-897

REASON 変更理由	サービス供給として設定する To supply as a spare part	COMMON MODEL 共通機種	2890-100		
Previous	-----	---	---	2890-0187-01	New



2890-0187-01
USB TERMINAL COVER
USB ターミナルカバー
To supply as a spare part.
サービス供給として設定

REF No. 管理No.	QS FA 2890-P004
------------------	-----------------

Division 主管部署	CS Division CS部
Valid from 施行年月日	April 27, 2004

Parts List P. 1

仮-897

REASON 変更理由	サービス供給として設定する To supply as a spare part	COMMON MODEL 共通機種	2890-100		
Previous	-----	---	---	2890-5851-01	New



2890-5851-01
ICE STICKER
ICE シール
To supply as a spare part.
サービス供給として設定

PML

■ 本案内状に従い、パーツリストへの転記等、メンテナンスを行なってください。

According to this list, correct "Parts List" in Service Manual for effective parts management.

KONICA MINOLTA PHOTO IMAGING, INC.

(2890)A 3

PARTS MODIFICATION LIST

REF No. 管理No.	QS FA 2890-P005
------------------	-----------------

Division 主管部署	Camera CS Division カメラCS部
Valid from 施行年月日	October 15. 2004

Approved by 承認	Verified by 審査	Written by 作成
Tanizaki	Naruto	Ueno

Parts List P. 1

仮-911

REASON 変更理由	サービス供給として設定する To supply as a spare part	COMMON MODEL 共通機種	2890-100	
Previous	-----	---	2890-0626-01	New

2890-0626-01
SCREW/ ねじ
Add./ 新説

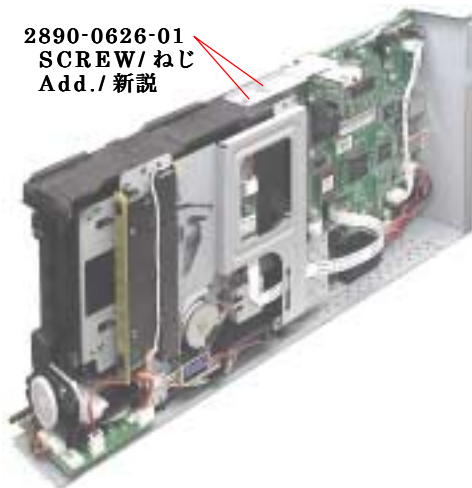

REF No. 管理No.	QS FA 2890-P006
------------------	-----------------

Division 主管部署	Camera CS Division カメラCS部
Valid from 施行年月日	October 15. 2004

Parts List P. 1

仮-911

REASON 変更理由	サービス供給として設定する To supply as a spare part	COMMON MODEL 共通機種	2890-100	
Previous	-----	---	2890-0037-01	New

2890-0037-01
WASHER/ ワッシャー
Add./ 新説

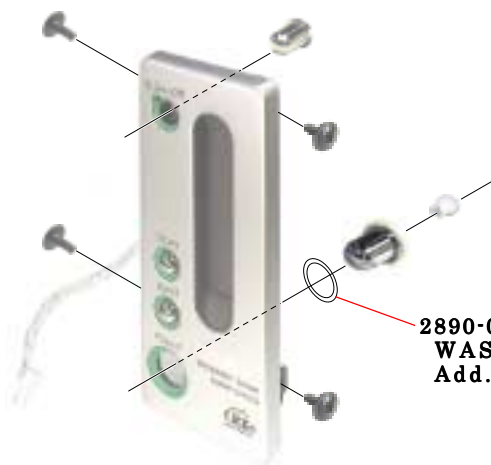

■ 本案内状に従い、パーツリストへの転記等、メンテナンスを行なってください。

According to this list, correct "Parts List" in Service Manual for effective parts management.

KONICA MINOLTA PHOTO IMAGING, INC.

PML

(2890)A 4

PARTS MODIFICATION LIST

REF No. 管理No.	QS FA 2890-P007
------------------	-----------------

Division 主管部署	Camera CS Division カメラCS部
------------------	-------------------------------------

Valid from 施行年月日	October 15, 2004
---------------------	------------------

Approved by 承認	Verified by 審査	Written by 作成
Tanizaki	Naruto	Ueno

Parts List P. 1

仮-911

REASON 変更理由	サービス供給として設定する To supply as a spare part	COMMON MODEL 共通機種	2890-100
Previous	-----	---	---
		2890-0188-01	New



2890-0188-01
IEEE CAP
IEEE キャップ
Add./ 新説

PML

■本案内状に従い、パーツリストへの転記等、メンテナンスを行なってください。

According to this list, correct "Parts List" in Service Manual for effective parts management.

KONICA MINOLTA PHOTO IMAGING, INC.

(2890) 5

PARTS MODIFICATION LIST

REF No. 管理No.	QS FA 2890-P008
------------------	-----------------

Division 主管部署	Camera CS Division カメラCS部
------------------	------------------------------

Valid from 施行年月日	July 15. 2005
---------------------	---------------

Approved by 承認	Verified by 審査	Written by 作成
Yata		Ueno

Parts List P. 2

仮-939

REASON 変更理由	サービス供給として設定する To supply as a spare part	COMMON MODEL 共通機種	2890-100
Previous	-----	---	2890-0065-01
Previous	-----	---	2890-0091-01

2890-0091-01
FOCUS MOTOR
 フォーカスマータ
 NEW/ 新規設定

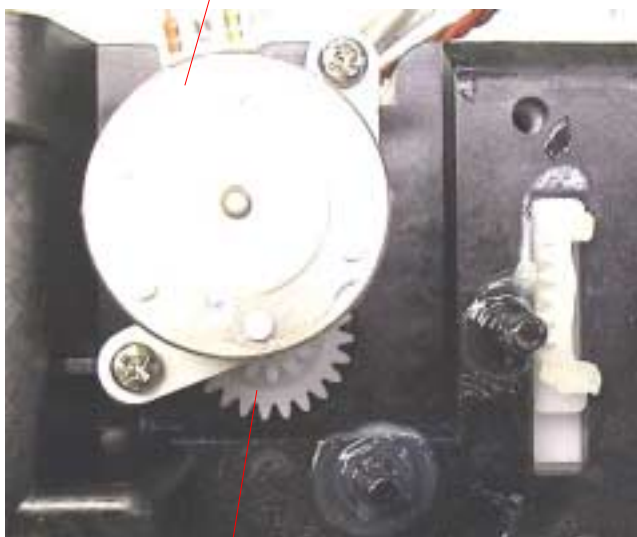

2890-0065-01
GEAR 24
 ギヤ24
 NEW/ 新規設定

PML

■ 本案内状に従い、パーツリストへの転記等、メンテナンスを行なってください。

According to this list, correct "Parts List" in Service Manual for effective parts management.

KONICA MINOLTA PHOTO IMAGING, INC.

REPAIR GUIDE

Contents of this manual are in accordance with the assembly procedure. Therefore, follow the reverse procedure when disassembling.

SYMBOLS

- : Caution and key points of assembly
- Ⓐ : Anti-diffusion agent
- Ⓑ : Adhesive
- Ⓒ Ⓚ : Grease
- Ⓓ : Tools

TABLE OF CONTENTS

Page

Assy, Scan unit, Main PCB Assy Installation	2
Focus dial, Arm, Assy, Front housing Installation	3
Measuring Instruments, Tools and Jigs	8
Subsidiary Materials	8

REPAIR GUIDE

PRECAUTIONS

Chemicals

Handle chemicals of high volatility with care, use of which will affect to your health and environment.

1. Store them sealed in a specific place to prevent from exposure to high temperature or direct sunlight.
2. Avoid dividing them into small containers and prevent from vaporization.
3. Keep containers sealed when not in use.
4. Avoid using them as much as possible. When required, remove only required amount from the container to make full use.

Plastic Parts

1. When cleaning the plastic parts, use cleaning paper or cloth. Never apply thinner, ketone, ether.
2. When installing the plastic parts, insert the specific screws vertically to the parts. (Be careful not to tighten too much.)

PCBs

Since PCBs use MOS IC, you must reduce static electricity.

When repair a PCB itself, or when wiring, please perform your work as illustrated below.

If grounding is impossible, connect a cable to a steel desk or shelf.

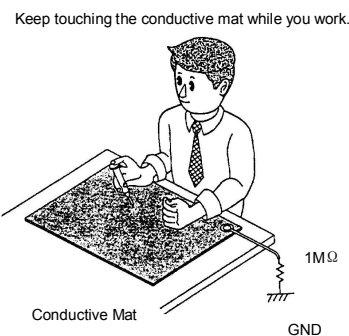

Assy, Scan unit, Main PCB Assy Installation

REPAIR GUIDE

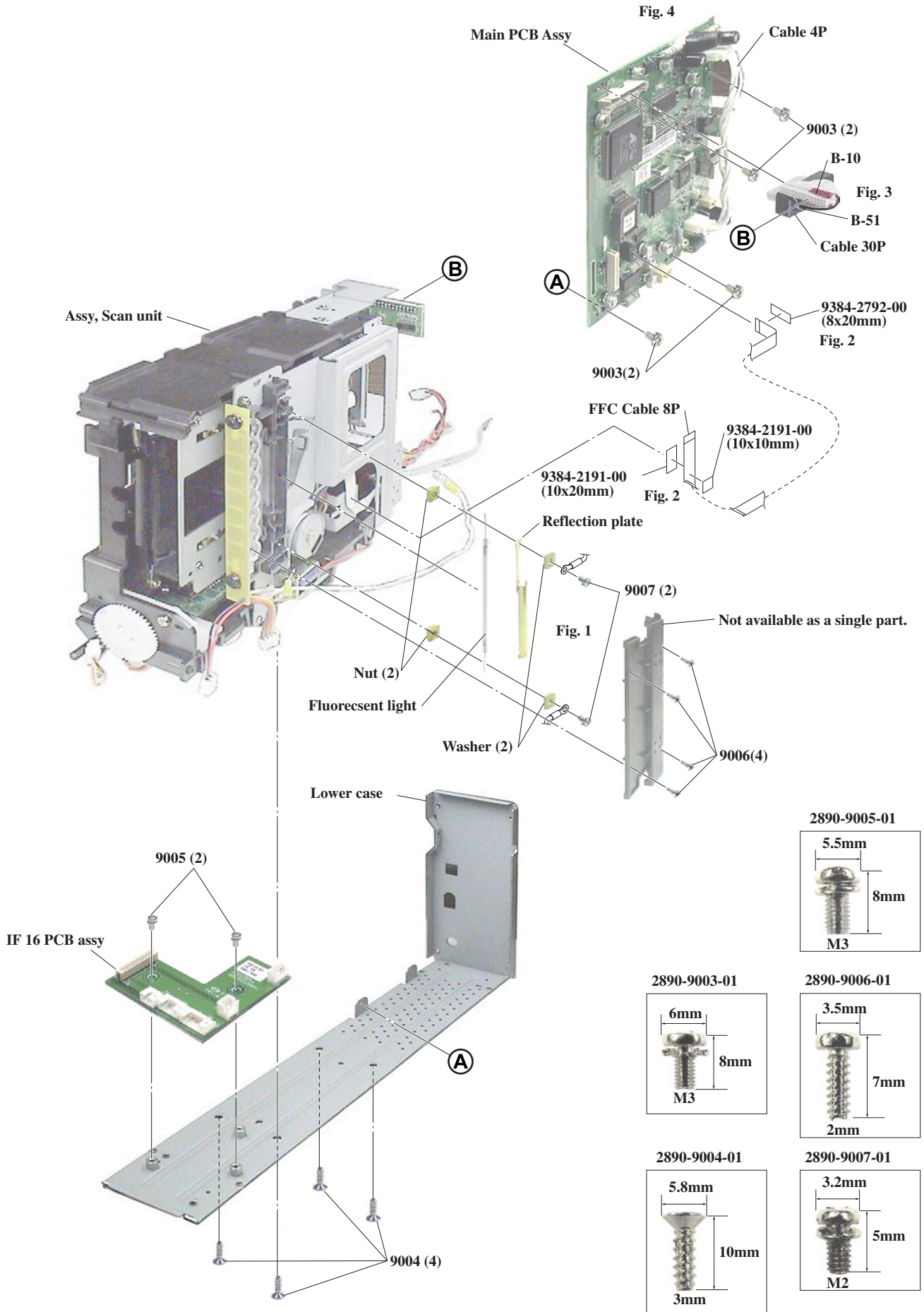

Focus dial, Arm, Assy, Front housing Installation

REPAIR GUIDE

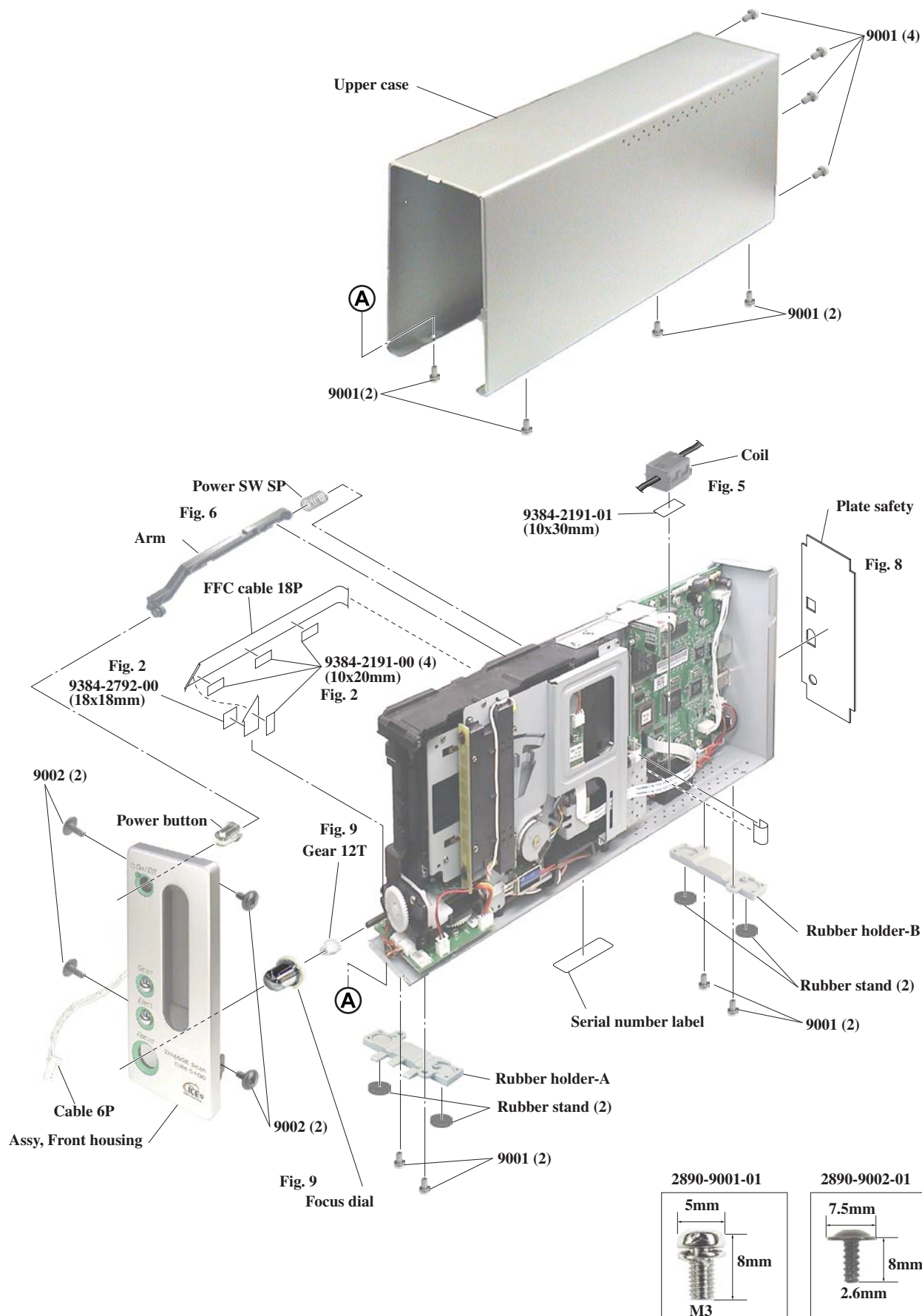

4 (2890) A

■ Fig. 1

Fluorescent Lamp Replacement Procedure.

Disassembly

1. Remove 4 fluorescent lamp holder (not supplied) fixing screws (9006) (in the circle). Never loosening fluorescent lamp holder fixing screws except the screws marked in the figure (in the circle).

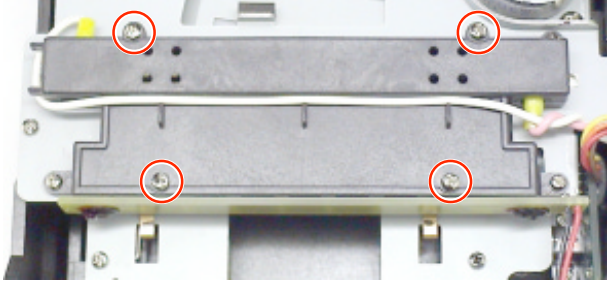

2. Remove 2 fluorescent lamp fixing screws (9007). Remove washers (9101), a reflection board (1102) and a fluorescent lamp.

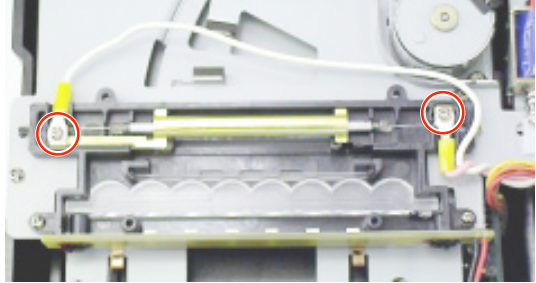

Assembly

1. Install nut (9102) to the fluorescent lamp holder (not supplied) and fluorescent lamp (4001) in a groove of the nut.

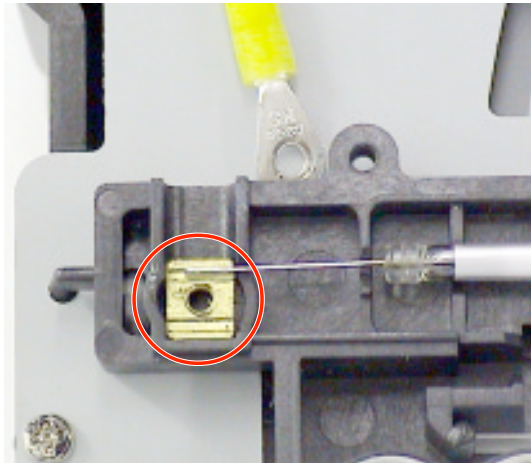

2. Install reflection boards (1102), washers (9101) and harness terminal, and install 2 screws (9007).

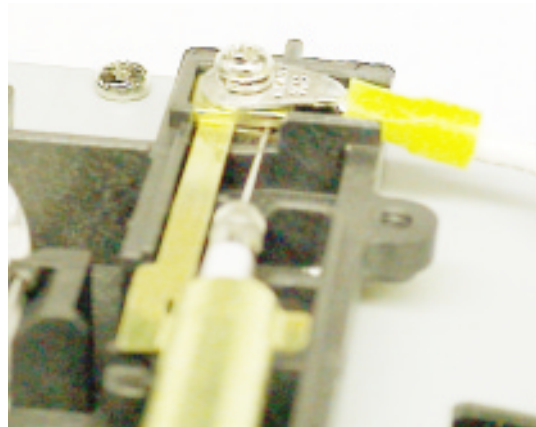

3. Install the fluorescent lamp holders (not supplied) and fix with 4 screws (9006). (See Disassembly step 1)

4. Arrange the harness.

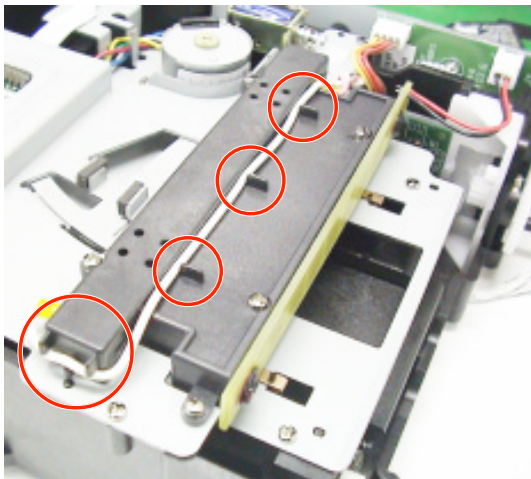

Notice:

When fixing fluorescent lamp terminal with screws, stress is applied, and a leak of fluorescence gas rarely occurs.

Be sure to leave the fluorescent lamp more than 24 hours (1 day), and please ship repair product after lighting confirmation of the fluorescent lamp.

Fig. 2

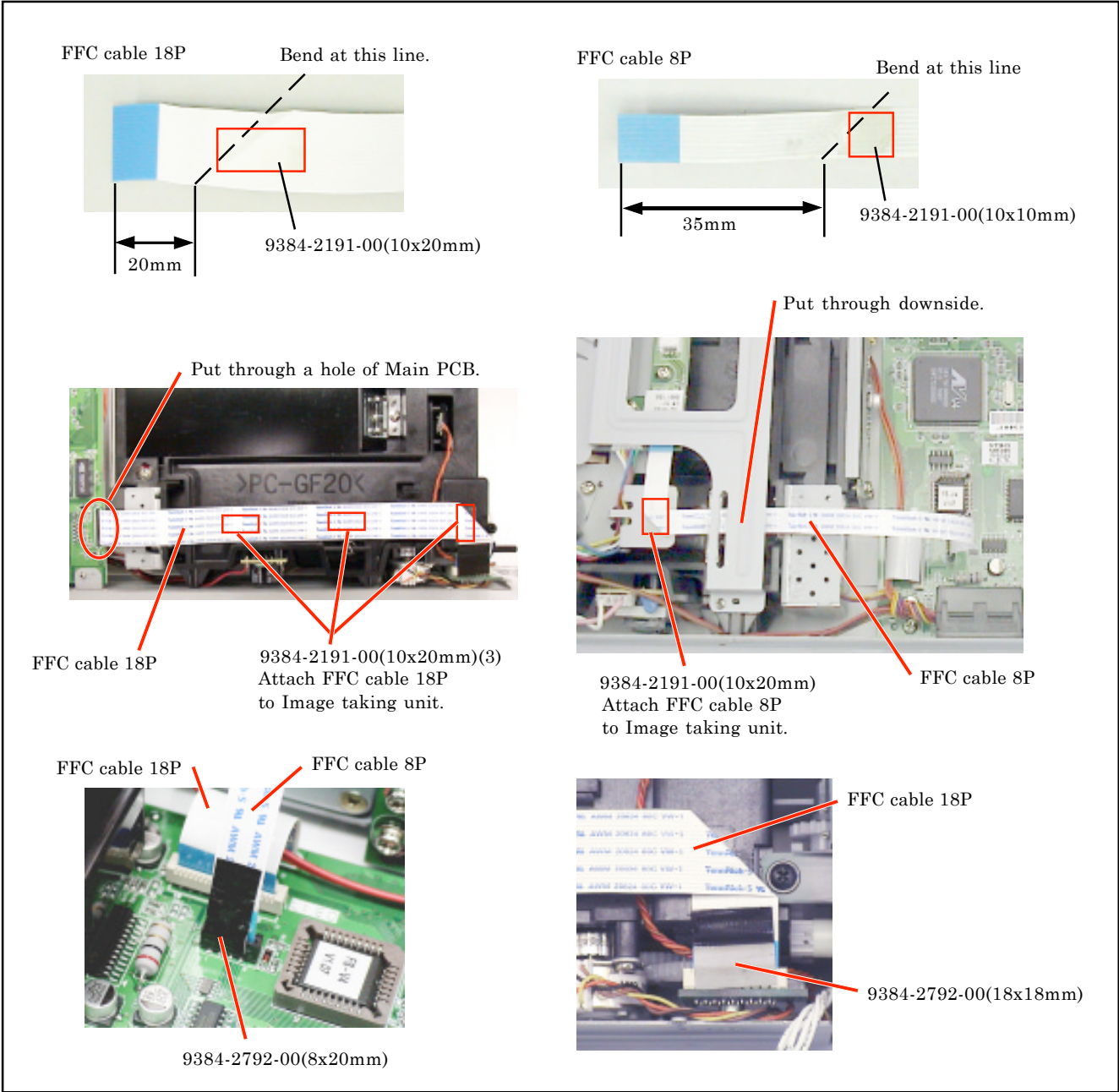

REPAIR GUIDE

Fig. 3

After connectig Main PCB Assy and Cable 30P, apply B-51 and B-10 to the connector of PCB as shown.

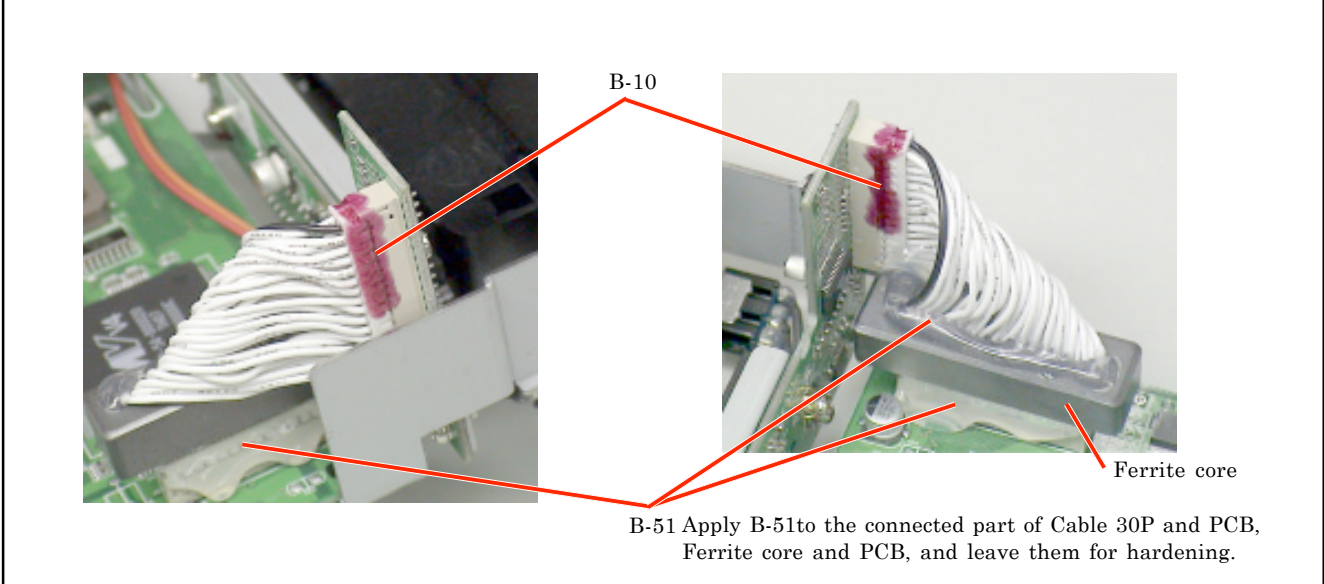

6 (2890) B

■ Fig. 4

Connect the connector by the position as shown.

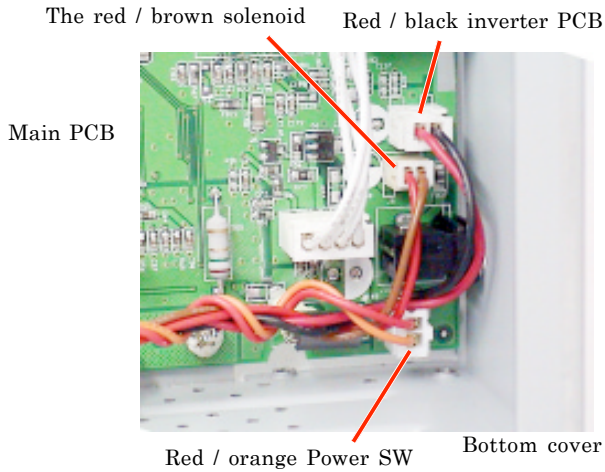

■ Fig. 6

Arm installation.
Install the arm notch aligning with the Image taking unit.
(in the circle)

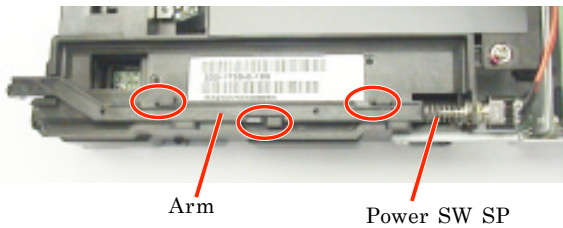

■ Fig. 7

Serial number installation.

Stick onto the center of the posts.

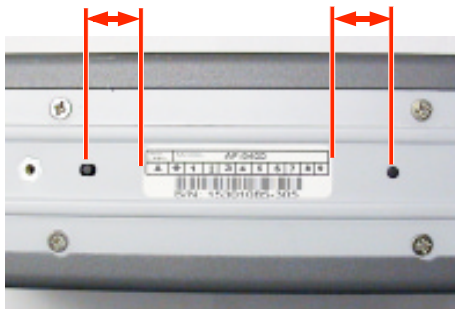

■ Fig. 5

Coil installation.

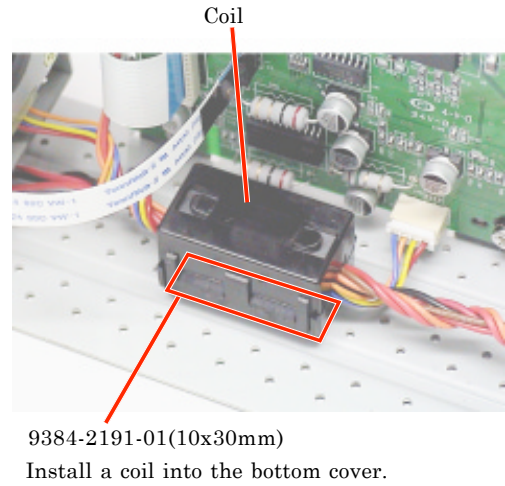

After installing the coil on the lower case with 9384-2191-01, apply B-51 into the shaded area to prevent the coil from detaching.

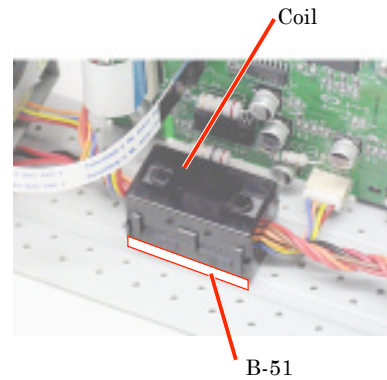

■ Fig. 8

Rating label installation.

Stick a rating label as shown in the figure after fixing top cover with screws.



Do not let it run over the top cover.

■ Fig. 9

Focus dial Assembly Procedure.

DiMAGE Scan Utility is necessary for this procedure. Please install "DiMAGE Scan" Software from CD-ROM to your PC.

Preparations

1. Remove top cover, front cover assy, focus dial and gear 12T.
2. Keep the front cover assy connected to the Image taking unit with cable 6P. (Fig. 9-1)
3. Connect scanner (2890) and PC via USB (or, IEEE1394) cable.
4. Power on the scanner.
5. Start "DiMAGE Scan Utility", and be standby for scanning.

Assembly

1. Keep the front door being opened with tape. (Fig. 9-2)
2. Insert a holder (35mm film holder or a slide mount holder) in a scanner. (it's arbitrary to set film or not) Holder moves in right and left direction, and stops at a central position.
3. Install gear 12T to Focus dial. Align a groove of gear 12T. (two places) with a projection of the focus dial inside, and install it. (Fig. 9-3)
4. Make an index (a dent) of a focus dial (a set with gear 12T) just above, and install it to a gear shaft. (Image taking unit).
5. Mark on the engaged part of gear teeth adjacent to the gear 12T with a felt pen. (Fig. 9-4)
6. Push an Eject button, and pull out a holder. After ejecting, Focus dial turns clockwise, and stops at the initial position.
7. Turn Focus dial manually in counterclockwise direction so that the index (a dent) appears just above. Check that position of the gear 12T and adjacent gear tooth (marked position) are fit.
8. Be sure to peel off the tape which was put in Assembly step 1 (Fig. 9-2).
9. Install the front cover assy and tighten with 4 screws (9002).

Check

Check the position and operation of the Focus dial. Connect an USB (or, IEEE1394) cable same as normal image bringing in, power on the scanner to start "DiMAGE Scan Utility".

1. Set an image in a holder (35mm film holder or a slide mount holder), and insert it in a scanner. The holder stops at a center position after moving in right and left.
2. Confirm that the index (a dent) of Focus dial is within a illustrated range. (between arrows) (Fig. 9-5) If it was out of the range, repeat from Assembly procedure step 1.
3. Preview the image set in step 1 on DiMAGE Scan Utility, and perform AF at any point. Check that the holder moves in left and right, moves again in short range, and then stops at the best focus point.
4. Push Eject button. Confirm that Focus dial returns to the initial position after ejecting. (the end position in clockwise direction)
5. Arrange cable 6P as shown. (Fig. 9-6)

Fig. 9-1

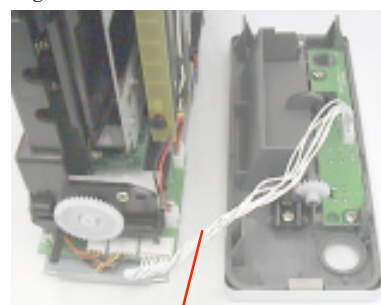

Cable 6P

Fig. 9-2

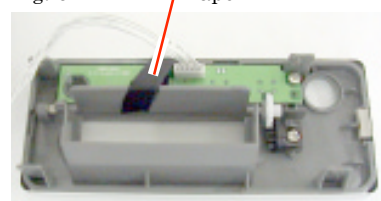

Tape

Fig. 9-3

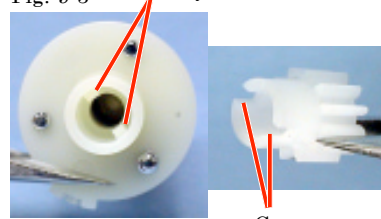

Projection

Focus dial

Groove Gear 12T

Fig. 9-4

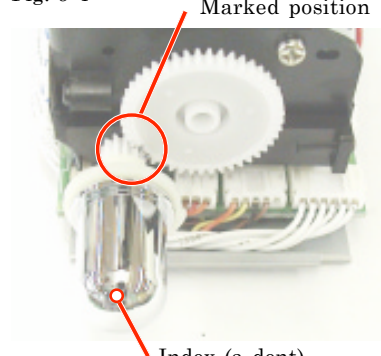

Marked position

Index (a dent)

Fig. 9-5



Index

Fig. 9-6

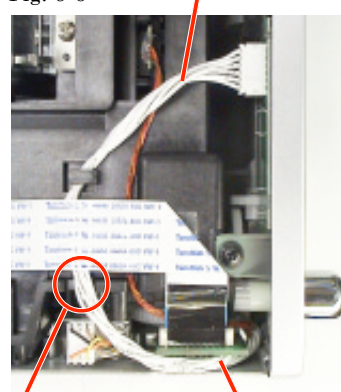

Cable 6P

Arrange at the notch.

Arrange under the PCB.

8 (2890) A

Measuring Instruments, Tools and Jigs

Slide Mount Holder (SH-M10)

DiMAGE Scan Ver. 1.1.0 (CD-ROM)

AC Adapter

PC/AT compatibles

CPU: Pentium III or later

RAM: 500MB or more

HDD: Approx. 2GB or more of available hard-disk space

OS: Windows 98, 98SE, Me, 2000 Professional

Monitor: 1024 x 768 (pixels) is recommended. High Color (16-bit)

Subsidiary Materials

Adhesive

B-10 <7984-2010-01>

B-51 <7984-2051-01>

CHECK LIST

1. This Check List describes the quality of operation warranted to general users.
When users inquire about quality or request inspection, refer to this Check List.
Use this list also when checking operation after repair.
2. When using this list at shipping or receiving inspection, judge the quality according to the purpose of the inspection, not by directly referring to this level.
3. For individual taste or special usage, some users may not be satisfied with this level of quality and will request a different one.
In such cases, adjust the level as required by them as much as possible.

Contents

NAMES OF PARTS	2
FUNCTION	3
POWER SWITCH	3
PC INTERFACE	3
EJECT BUTTON	3
QUICK SCAN BUTTON.....	3
MANUAL FOCUS DIAL	3
INDEX SCAN	3
PRESCAN	3
SCAN	3
PERFORMANCE	4
SCANNER GAUGE CHART	4
COLOR CHART	8
STANDARD	11
EQUIPMENT REQUIRED	12

CHECK LIST

2 (2890) A

Check the scanner with the computer which meets the system requirements in the last page of this check list.

The driver software DiIMAGE Scan supplied with the product is necessary for check. If this driver is not installed in the computer, please install it beforehand.

NAMES OF PARTS

1. **Front Door**
2. **Indicator Lamp**
Glows steadily: Scanner is ready to use.
Off: Power off
Blinks slowly: Scanning, Loading, or initializing.
Blinks rapidly: Error
3. **Power Switch**
4. **Front Door reset hole**
5. **Quick Scan button**
6. **Eject Button**
7. **Manual Focus Dial**
8. **USB Port**
9. **IEEE1394 (FireWire) Port**
10. **DC Terminal**

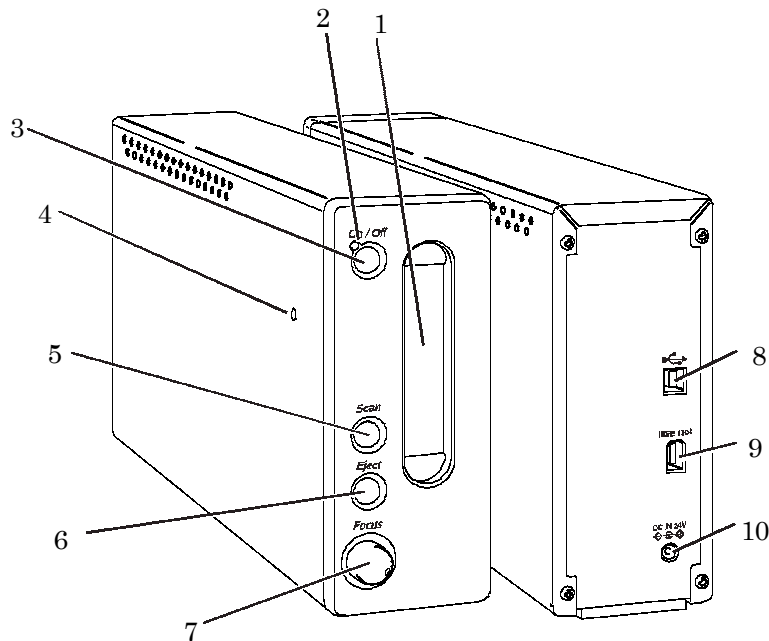

FUNCTION

Power Switch

ON

Before starting the driver, the indicator blinks.

At using the driver software, the indicator lamp glows or blinks accordingly as below.

Lamp	Condition
Glowing	Normal except for the following.
Blinking slowly at 1Hz	Mechanical drive (setup)
Blinking fast at 8Hz	Error

OFF

The indicator lamp turns off.

PC Interface

USB 2.0 / 1.1 or IEEE1394

Eject button

When the scanner is not operating (stand-by), pressing the Eject button ejects the holder immediately.

Quick Scan button

When the scanner is not operating (stand-by), pressing the Quick scan button launched desired application software.

In default setting, DiMAGE Scan Launcher starts.

DiMAGE Scan Launcher enables to select the application which starts when pressing the Quick Scan button.

If the batch scan utility is selected, the scanner starts scanning.

Manual focus dial

When the Manual focus dial is selected in the preferences window, manual focusing can be used on any point in the preview image.

While selecting the Manual focus dial, the Autofocus at scan is disabled.

Index Scan

Displays index in high speed or high quality as set in the preferences.

Prescan

Scans selected frames and displays on the prescan tab window.

Scan

Scans a selected frame and saves or export the image.

When selecting multiple images, scans them sequentially. (slide: max.4 frames/ film strip: max.6 frames)

CHECK LIST

4 (2890) A

PERFORMANCE

Outline

Basically, 2890 performance will be checked accordingly as below.

Scan: Scan the chart and save the image with the driver software.

Measure: Take in the image and measure the data with the Adjustment program.

Check: Output the data in the excel sheet and check the performance.

Chart and check items:

Scanner gauge chart: magnification, skew, color registration, pitch accuracy, frequency characteristic

Color chart: output density, grayscales, color balance, color reproduction

The following procedure describes the method in detail.

Scanner Gauge Chart

Preparation

2890 Adjustment Program FD Version 1.0
2887 Adjustment Program CD Version 1.0
DiIMAGE Scan Ver. 1.1.0 (CD)
Scanner Gauge Chart (35mm)
Slide Mount Holder (SH-M10)
Microsoft Excel

Installation

1. Drag and copy "DiIMAGEScan.ini" in the 2890 Adjustment Program FD to the folder where the DiIMAGE Scan.exe is installed. (C: Program Files \DiIMAGE Scan)

If the driver software DiIMAGE Scan is not installed yet, please install the driver software first.

Be sure to remove the DiIMAGEScan.ini from the folder after scanning the chart. Otherwise images will be underexposed or error message will appear when scanning images other than the scanner gauge chart.

2. Double click the Setup.exe at "CD:Scanner Gauge Chart Evaluate \DISK1 in the 2887 Adjustment Program CD. Installation will start automatically.

If 2887 Adjustment Program is launched on your computer, the above procedure is not necessary.

CAUTION: The dialog box below may appear under the English environment OS, but the program completes the installation successfully and will restart the PC appropriately. Click the following point "A".

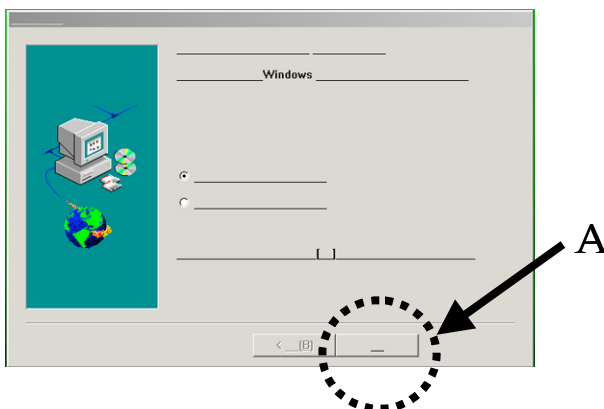

Setting the chart

Make sure the chart faces the CCD side in the Slide Mount Holder (SH-M10) as illustrated.

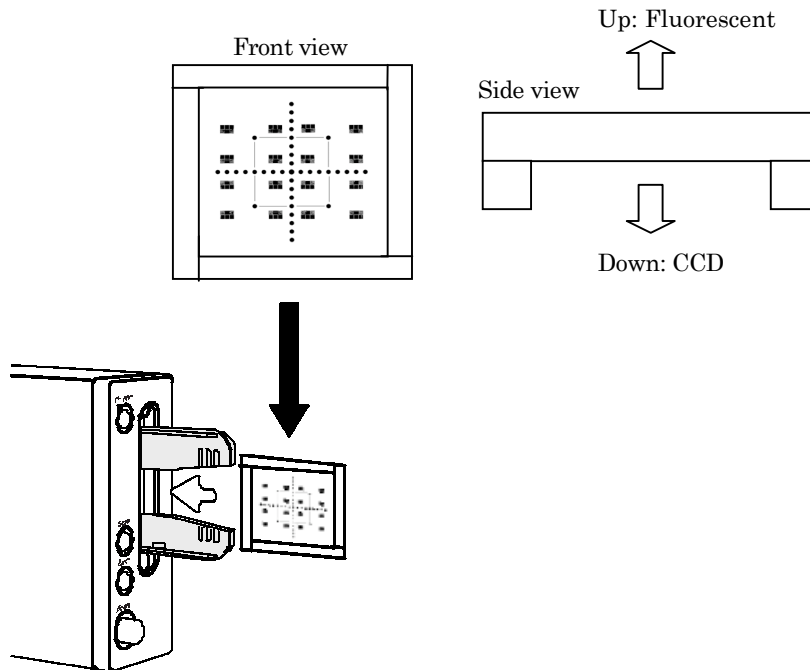

Scan

- 1) Click Start > Programs > Minolta DiIMAGE Scan Ver. 1.1 > DiIMAGE Scan Utility.

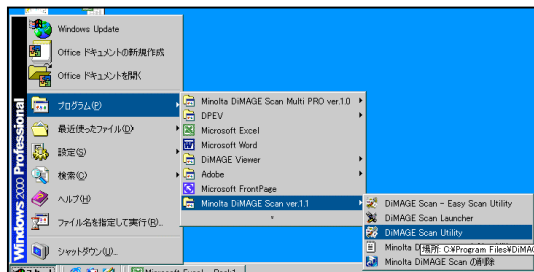

- 2) Set the preferences as below.

Scanning condition

Film format	35mm
Film type	Color Positive
Input resolution	5400 dpi

6 (2890) A

- 3) Select the blank area (A) and click the Prescan button and confirm if each RGB value is 200 ± 30 .

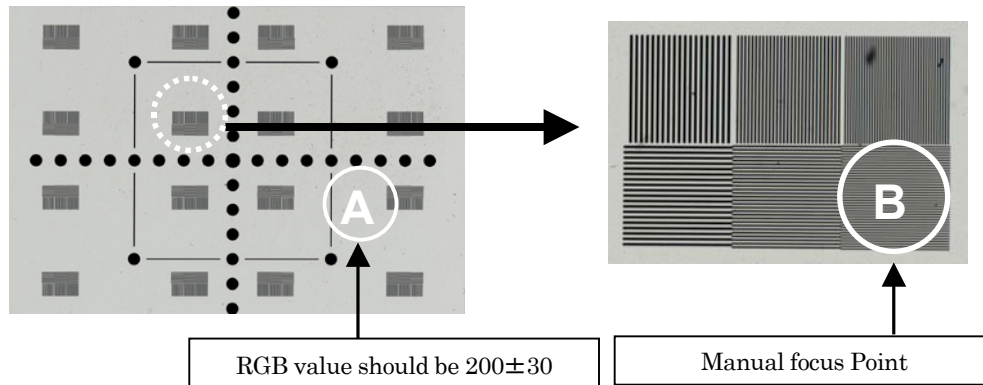

- 4) Click on the Manual focus button and move the mouse pointer to the manual focus point (B), then drag the focus meter slider until the black and white lines are at their longest.

CAUTION: Drag the slider from the left to the right.

- 5) Confirm that the image is selected entirely, and click the Scan button to start the final scan.
- 6) Save the image as .BMP file.

CAUTION: Chart scanning time is depending on the system configurations of the computer.

CHECK LIST

Measurement

- 1) Select Start > Program > DPEV > GEOM.

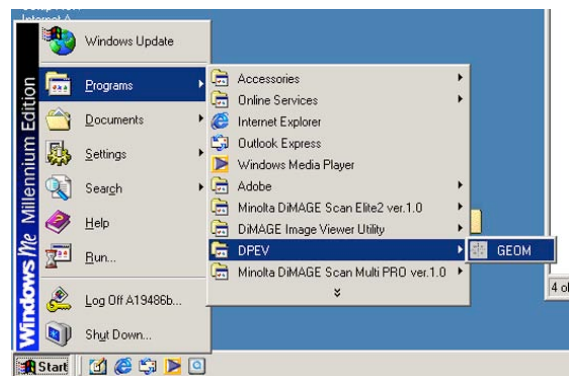

- 2) Click Setup > Measure and set the preference as below.

Measuring condition

Size	Auto Detect
Resolution	5400 dpi
Chart Size	135
MTF	20/30/40
Measure item	Check all
Data Out	Auto Save
Pasted MTF-Data	40

Click the Profile "New" and input a profile name, and then click the Save button. (The setting will be effective from the next measurement.)

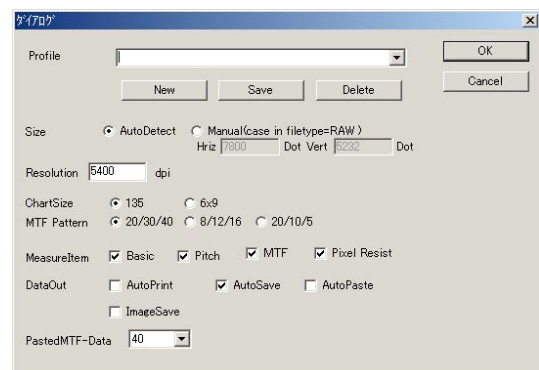

- 3) Click File > File Open and select the image file saved in 1.3.7). The result will be copied in a clipboard on PC.

CAUTION: Paste the result data on an excel sheet in the next step before using other applications. Otherwise the result will be lost.

Check

- 1) Open 2890data sheet.xls in the FD and select the worksheet "Scanner Gauge".
- 2) Move the mouse pointer to the cell F3, and click Edit > Paste.
The file name is inputted in F3 and the performance data is inputted in the column F.
- 3) Confirm that the cell G3 is null. * mark in G3 indicates that some of the data was beyond the standard. Check the items marked * in the column G. (blank: within standard, *: out of standard)

Be sure to remove the DiMAGEScan.ini from the folder after scanning the chart. Otherwise images will be underexposed or error message will appear when scanning images other than the scanner gauge chart.

	A	B	C	D	E	F	G	H	I
1	2890 Scanner Gauge Chart								
2									
3				Standard	+/-				
7			Vertical direction	0	1.5				
8	Magnification		Horizontal direction	0	1.5				
9			Aspect Ratio	0	1.0				
10			Vertical direction	0	0.5				
11	Skew		Horizontal direction	0	0.5				
12			Diagonal direction	0	0.5				
13	Color Registration		Vertical direction	0	1.5				
14			Horizontal direction	0	1.5				
17									
18			-9	0	1.0				
19			-7	0	1.0				
20			-5	0	1.0				
21			-9	0	1.0				
22	Pitch Accuracy(Vertical)		-1	0	1.0				
23			1	0	1.0				
24			3	0	1.0				
25			5	0	1.0				
26			7	0	1.0				
27			9	0	1.0				
28			-15	0	1.0				
29			-18	0	1.0				

CHECK LIST

8 (2890) A

Color Chart

Preparation

2890 Adjustment Program FD Version 1.0
2887 Adjustment Program CD Version 1.0
DiMAGE Scan Ver. 1.1.0 (CD)
Color Chart Slide (35mm)
Slide Mount Holder (SH-M10)
Microsoft Excel

Setup

1. Confirm the driver software DiMAGE Scan Ver. 1.1.0 is launched or not.
If not installed yet, please install the driver software first.

Be sure to remove the DiMAGEScan.ini from the folder after scanning the chart.
Otherwise images will be underexposed or error message will appear when scanning
images other than the scanner gauge chart.

2. Install 2887 Adjustment Program.

Double click the Setup.exe at "CD: Scanner Gauge Chart Evaluate \DISK1 in the 2887 Adjustment Program CD. Installation will start automatically.

If 2887 Adjustment Program is launched on your computer, the above procedure is not necessary.

Drag and copy the 90Color135.txt from the 2890 Adjustment Program FD to your computer.

3. Load the Color Chart Slide in the Slide Mount Holder (SH-M10) so that the jig No. is visible from the fluorescent lamp side.

CHECK LIST

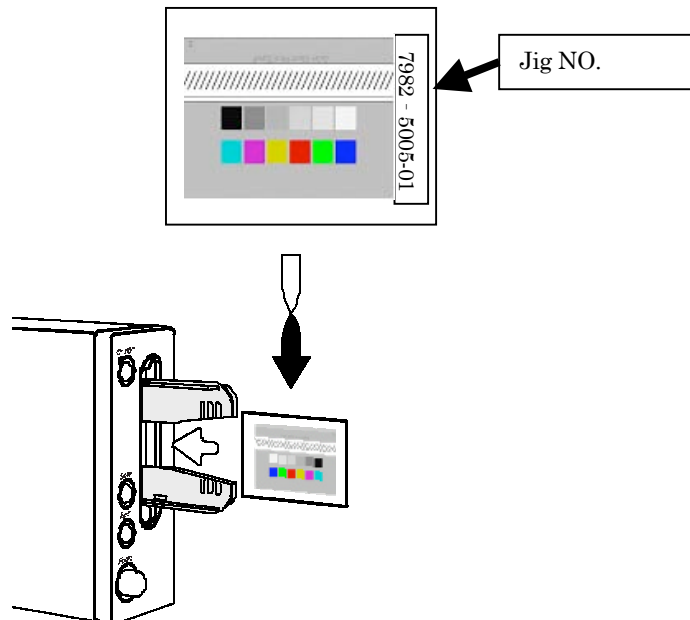

Scan

- 1) Click Start > Programs > Minolta DiIMAGE Scan Ver. 1.1 > DiIMAGE Scan Utility.
- 2) Set the preferences as below.

Scanning condition

Film format	35mm
Film Type	Color Positive
Input resolution	540 dpi

- 3) Click on the Prescan button to prescan the chart.
Check that the chart is scanned as shown and that it is not underexposure.

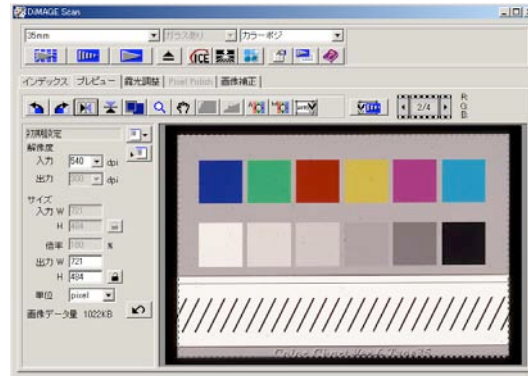

- 4) Click on the Point AF button and move the mouse pointer to the center of the image and then start the Auto Focus.
- 5) Make sure that all the area of the image is selected and click on the Scan button.
- 6) Save the image as .BMP file.
- 7) Add “_P0” after the file name as suffix (***(file name)_P0.BMP).

Measurement

- 1) Click Start > Program > DPEV > ColorEV.

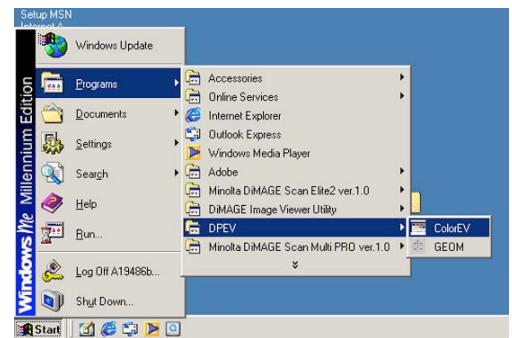

- 2) Click Setup > Measure, and set the preference as below.

Measurement condition

Category	Scanner
Resolution	540 dpi
Chart	135
Ver	6
Standard	90Color135.txt
Data Out	Auto Save
Locate	File Group Vert:0 Hriz:0 Scale: 1
Sample Area	1.5
Gamma	1.4
Light Source	D65 (Std)

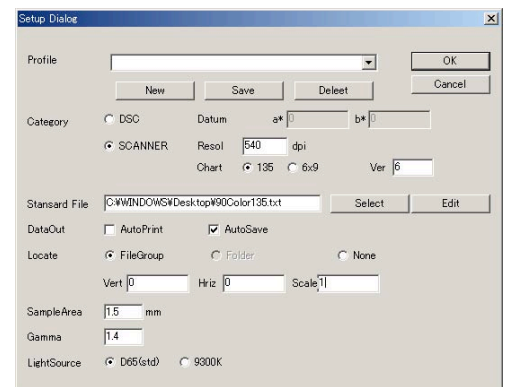

CHECK LIST

10 (2890) A

- 3) Click “New” of the Profile and input a profile name, and then click on the Save button. The setting will be effective from the next measurement.
- 4) Click File > File Open and select the image file saved in Scan step 6).
- 5) Click the direction buttons (A) until the measuring points are at the center of each color, and click OK button.

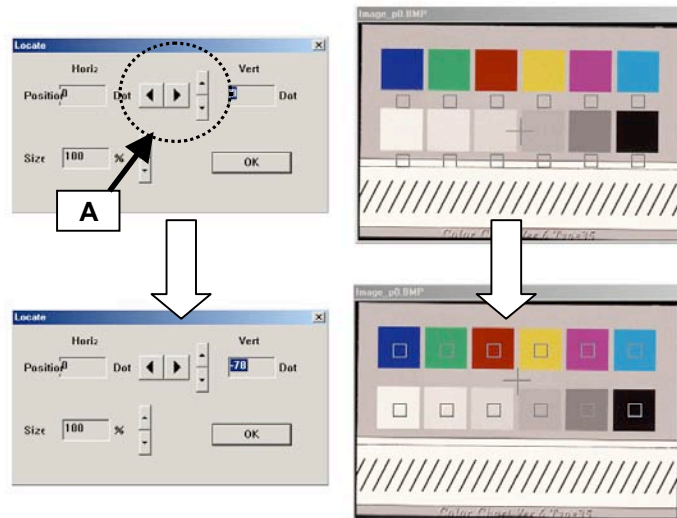

- 6) The result will be copied in a clipboard on PC.

CAUTION: Paste the result data on an excel sheet in the next step before using other applications. Otherwise the result will be lost.

CHECK LIST

Check

- 1) Open 2890data sheet.xls in the FD and select the worksheet “Color Chart”.
- 2) Move the mouse pointer to the cell F3, and click Edit > Paste. The file name is inputted in F3 and the performance data is inputted in the column F.
- 3) Confirm that the cell G3 is null. “xxx” mark in G3 indicates that some of the data was beyond the standard. Check the items in the column G (•• •: within standard, xxx: out of standard)

	B	C	D	E	F	G	H	I
1	2890 Color Chart							
2								
3			Standard	+/-				
4		White	94		5			
5		Black	14		8			
12		White	100	---				
13		Gray2	94		6			
14		Gray3	89		5			
15		Gray4	77		5			
16		Gray5	61		5			
17		Black	17		5			
36		White			10			
37		Gray2			10			
38		Gray3			10			
39		Gray4			10			
40		Gray5			10			
41		Black			16			
48		B-a*	23		10			
49		B-b*	-53		10			
50		G-a*	-44		10			

Standard**Scanner gauge chart**

Magnification

	+/-
Vertical	$\pm 1.5\%$
Horizontal	$\pm 1.5\%$
Aspect ratio	$\pm 1.0\%$

Skew

	+/-
Vertical	$\pm 0.5\%$
Horizontal	$\pm 0.5\%$
Aspect ratio	$\pm 0.5\%$

Color Registration

	+/-
Vertical	± 1.5 pixel
Horizontal	± 1.5 pixel

Pitch Accuracy

	+/-
Vertical	$\pm 1.0\%$
Horizontal	$\pm 1.0\%$

Frequency Characteristic

		Range
Center	Vertical	50 % (40 lines/mm) or greater
	Horizontal	50 % (40 lines/mm) or greater
Around	Vertical	40 % (40 lines/mm) or greater
	Horizontal	40 % (40 lines/mm) or greater

Color chart

Output Density

Chart	Range
White	94 ± 5
Black	14 ± 8

Grayscale

Chart	Range
Step 1 White	100
Step 2 Gray2	94 ± 6
Step 3 Gray3	89 ± 5
Step 4 Gray4	77 ± 5
Step 5 Gray5	61 ± 5
Step 6 Black	17 ± 5

Confirm that L* value is less than 100, and all the values are in descending order toward Black as shown above.

12 (2890) A

Color Balance

Chart		+/-
Step 1	White	10 or less
Step 2	Gray2	10 or less
Step 3	Gray3	10 or less
Step 4	Gray4	10 or less
Step 5	Gray5	10 or less
Step 6	Black	16 or less

Color Reproduction

Chart	a*	b*
B	23 ± 10	-53 ± 10
G	-44 ± 10	13 ± 10
R	48 ± 10	46 ± 10
Y	-5 ± 10	51 ± 10
M	50 ± 10	-19 ± 10
C	-18 ± 10	-32 ± 10

Equipment Required

PC/AT compatibles

CPU	Pentium III or later
RAM	500MB or more
HDD	Approx. 2GB or more of available hard-disk space
OS	Windows 98, 98SE, Me, 2000 Professional
Monitor	1024 x 768 (pixels) is recommended. High Color (16-bit)

CHECK LIST

2890 Adjustment Program FD Version 1.0 <2890-0001-75>

FD ——— DiMAGEScan.ini
 ——— 90Color135.dll
 ——— 2890_data sheet.xls

2887 Adjustment Program CD Version 1.0 <2887-0001-75>

Scanner Gauge Chart (35mm) <7982-5002-01>

Color Chart Slide (35mm) <7982-5005-01>

Slide Mount Holder (SH-M10)

Microsoft Excel

DiMAGE Scan Ver. 1.1.0 (CD-ROM)

AC Adapter