



**dacor.**

Family-Owned. American-Made.



**PARTS  
CATALOG**

**Raised Vent**

<b>RV30, 36, 46</b>	<b>Service Manual</b>
RVC	RVR



# Field Service Bulletin

***dacor***<sup>®</sup>

Page 1 of 1

<b>Issued By:</b> Technical Service	<b>Date Issued:</b> 4-2004	<b>Distribution:</b> Service/Parts	<b>Supercedes:</b>
<b>Subject:</b> Service Issue	<b>Product Type:</b> Ventilation	<b>Model No:</b> RV	<b>Bulletin No:</b> 04-07

## RV Speed Control

RV30, 36 & 48 produced after 1/30/04: units equipped with the 12A control board part # 72881, the mounting screw for the main terminal board *could* be in contact with the heat sink on the control board. If the board is touching the heat sink symptoms will include: inability to change speeds at the touch pad, and the blower operating as soon as the unit is prompted to rise.

In some cases, the board may be damaged, however, preventing the screw from contacting the heat sink will usually correct the malfunction.

Units affected are RV 30, 36, & 48 with serial # prefix of 0405 and above. If you have questions, please contact Technical Service 800-35-DACOR.

### **Theory of Operation**

When keypad up/down button is pushed, contacts on the main PCB close between #12 and #13. Closing these contacts activates the triac for the sleeve motor which is connected to terminals L3 and N3 on the main PCB. The motor then raises the intake assembly until contact is made with the up stroke limit switch opening the circuit and reversing the electronic switch on the main PCB. When pressed again, the cycle reverses itself and stops in the retracted position.

### **VENT PCB DIAGNOSIS (ALL MODELS)**

Warning – With the motor disconnected, and the vent in the down position, 120VAC will be present between terminals L2 and N2 on the main PCB. When testing for a load, the motor must be connected to these terminals.

<b>Vent in Down position</b>	<b>Expected Voltage Reading:</b>
120 Volts AC	across L2 and N2 with no load (wires disconnected from motor)
Zero Volts AC	Voltage reading across L2 and N2 with motor connected (under load)
120 Volts AC	Reading from L2 to Ground with motor connected
120 Volts AC	Reading from N2 to Ground with Motor connected
120 Volts AC	Reading from L2 to Ground with Motor disconnected
<b>Vent in up position and under load with motor connected:</b>	
120 Volts AC	From L2 to Ground
Zero	From N2 to Ground
120	Reading across L2 and N2

### Keypad Diagnosis (All Models)

Of all the returned keypads the most common problem is poor electrical contact between the Touch Pad and the Contact Board. In the majority of these cases the Keypad Assembly is replaced unnecessarily. Before replacing the Keypad Assembly check for a foreign material between the Touch Pad and the Contact Board. Examples of foreign material include grease, cooking residue, moisture, or residue from cleaning agents. Circuit board cleaner or equivalent (available from electronic supply stores) should be used to clean the keypad assembly.

To diagnose the keypad:

1. Disconnect the Keypad Molex plug at the Main PCB and attach leads of an ohmmeter to pins #12 and #13.
2. Push the UP/DOWN button. This must show a closed circuit.

If the above test does not show a closed circuit, perform the following.

- ◆ Check for grease or any foreign material between the Touch Buttons and the contact board. Clean with an electronic contact cleaner as described above.
- ◆ Repeat test above.
- ◆ If the contacts are clear, replace the keypad assembly.
- ◆ If the circuit is closed, check for 120VAC between contacts N3 and L3 on the main PCB. If voltage is not present, replace the main PCB.

#### Button Contacts

UP/DOWN	12	13
HIGH SPEED	11	10
MEDIUM SPEED	5	10
LOW SPEED	12	10
DELAY	14	5
STOP	12	14
CLEAN	11	14

#### KEYPAD – CIRCUIT BOARD MOLEX PLUG WIRING ORDER

TERMINAL #	OLD STYLE	NEW STYLE
#1	BROWN	DARK GREEN
#2	RED	BRN W/WHITE
#3	ORANGE	BLUE
#4	YELLOW	BROWN
#5	GREEN	GRAY
#6	BLUE	RED
#7	PURPLE	PURPLE
#8	BRN W/WHITE	PINK
#9	RED W/WHT	WHITE
#10	ORANGE W/BLACK	ORANGE
#11	YELLOW W/BLACK	BLACK W/WHITE
#12	GREEN W/BLACK	BLACK
#13	BLUE W/BLK	BLACK
#14	PURPLE W/WHITE	LT GREEN

Wires Are Numbered 1 Through 14 And The Molex Plug Is Physically Numbered.

#### Voltage output for fan speed

Voltage output from the main PCB to the exhaust fan motor:

Low	77VAC	87VAC
Medium	94VAC	101VAC
High	115VAC	115VAC

Measurements of voltage are average readings, as actual measurements will vary with incoming voltage into the home.

## **Possible Failures**

### **A. Unit dead on arrival**

1. Check the keypad to be sure that the Lockout Mode has not been activated (look for the two LED's) To disable press and hold the HIGH and LOW button for a minimum of 1.0 second.
2. Check voltage between N1 and L1 on the main PCB. The voltage should be 120VAC. If voltage is not present check the incoming power supply and all wiring connections. A miswired unit may cause the PCB to fail.
3. Check the Keyboard wiring harness and Molex receptacle for open or loose wires. Make sure that the Molex plug is securely attached to the main PCB.

### **B. Unit will not raise or Lower:**

1. Check limit switches and the connecting wiring.
2. Check main PCB between L3 and N3 for 120 VAC when the UP/DOWN key is pressed. If voltage is not present check between terminals #12 and #13 on the PCB for continuity when the up/down key is depressed. If there is no voltage or continuity the PCB is defective and must be replaced.

### **C. Vent will go up but motor will not run:**

1. Check for proper wiring to the exhaust motor. The majority of motors failing to operate on new units are the result of incorrect installation wiring.
2. Look for miswired or defective limit switches. Review the functional and operational descriptions of the limit switches.
3. Check voltage output to exhaust motor. This should be 120VAC on the high-speed setting.
4. Raise the vent or press the high-speed button. Spin the exhaust motor, if motor runs check capacitor.
5. Check for defective PCB. See section on PCB Diagnosis.

### **D. Vent will not stop, goes up and down continuously:**

1. Check for misaligned or defective limit switches.
2. Check wiring between the limit switches and main PCB.

### **E. Blower runs only when the vent is down.**

1. Check for proper wiring at the PCB
2. Check for defective limit switches
3. Check for defective PCB. See section on PCB Diagnosis.

### **F. Vent only goes part way up; user must push keypad repeatedly.**

1. Check for a loose wiring harness or loose wire connections.
2. Check for dirt or grease on the Touchpad and Contact board. See section on KeyPad diagnosis.
3. Check for defective PCB. See section on PCB diagnosis.

### **G. Vent operates by itself:**

For this to occur the main PCB is detecting some type of electrical interference. Check for the following:

1. The installation instructions require a correctly grounded and dedicated circuit. If the unit is connected to a non-dedicated circuit refer the customer back to the installer and inform them that they will be responsible for future repairs until the wiring is corrected.

2. If the problem can be traced or associated with the use of an electronic gas cooktop (of any design) then a filter assembly (part number 86325) should be installed.

#### **H. Filter light stays on:**

1. If the filter light remains on after the filter button is depressed remove power to the unit to deposit to replace the P.C.B
2. If the light remains on after resetting the microprocessor, replace the main PCB

#### **I. Main PCB keeps shorting out:**

1. Check for reversed polarity on the incoming power supply.
2. Check for possible miswire of the exhaust motor.

#### **Quick Check – Main PCB:**

If the vent is not working at all

- ◆ Check the fuse on the main PCB
- ◆ If the fuse is good check for continuity between the fuse and L3 (drive motor terminal)
- ◆ If this circuit is open the PCB is bad and must be replaced.

When reassembling please be sure all the wiring is correct.

### **KEYPAD, KEYBOARD REPLACEMENT RV SERIES RAISED VENT**

#### **Removal of the cooktop is not required.**

- ◆ Raise the vent sleeve by pressing the UP/DOWN button. If the unit is dead, raise the vent by removing the black motor sleeve wires L3 and N3 from the main PCB and hook direct to a power source (Auxiliary power cord, pigtail etc)
- ◆ With the vent in up position turn off the electrical power to the vent and remove the vent electric cover plate.
- ◆ If a cabinet blower is used, disconnect the blower from the vent by loosening the three wing nuts located above the blower and lifting up on the blower retaining bracket.
- ◆ If a remote blower is used remove the cover plate.
- ◆ Disconnect the 14 wire Molex plug from the main PCB.
- ◆ Remove the screws, 1 on each side of the sleeve. Lift topcap assembly from the sleeve assembly. Guide the Molex plug through the electric box and through the channel in the sleeve assembly.
- ◆ Remove the right end cap (pressed in). Slide out the bezel, keypad and keyboard as one unit. Replace desired part and reinstall in reverse order.

#### **OFF BUTTON**

Pressing and releasing this button will switch off the fan motor. The fan speed indicators will be switched off and the OFF LED will be switched on. The OFF LED will only be switched on to indicate the fan motor is switched of whenever the UPPER LIMIT switch is closed.

If DELAY OFF function is on, this will also be cancelled by pressing the OFF button.

#### **DELAY OFF BUTTON**

This button has a toggle action. Pressing and releasing this button will enable the five-minute DELAY OFF function. Pressing and releasing this button again will cancel the selected DELAY OFF function.

When the DELAY OFF function is selected, the fan will continue to operate at the selected speed for five minutes and then turn off automatically.

During this five-minute interval the fan speed can be changed by pressing and releasing the HIGH, MEDIUM, or the LOW button.

#### **FAN SPEED – LOW BUTTON**

Pressing and releasing this button will select the low speed for the fan. The LOW speed LED indicator will be on indicating the selected fan speed. Both the MEDIUM and HIGH LED will be off.

#### **FAN SPEED – MEDIUM BUTTON**

Pressing and releasing this button will select the medium speed for the fan. The MEDIUM speed LED indicator will be on and both the LOW and HIGH LED will be off.

#### **FAN SPEED -HIGH BUTTON**

Pressing and releasing this button will select the HIGH speed for the fan. The HIGH speed LED indicator will be on and the LOW and MEDIUM LED will be off.

#### **CLEAN FILTER BUTTON**

When the total number of hours that the fan has operated exceeds 10 hours, the FILTER CLEAN LED will be on indicating the fan has accumulated over 10 operating hours.

Pressing and releasing the FILTER button enables this 10-hour timer to reset, and turns off the FILTER CLEAN LED. This button only becomes operational after the FILTER CLEAN LED is on.

#### **UP/DOWN BUTTON**

This button is used to control the sleeve motor. Pressing and releasing this button will stop the fan motor and cancel the DELAY OFF function (if selected). However, this button can carry out three different operations to the sleeve motor.

If the sleeve motor is in its upright position, pressing and releasing this button will start the sleeve motor and lower the vent.

Pressing and releasing this button again before the vent has lowered to its lowest position will stop the sleeve motor. After the vent has stopped, pressing and releasing this button again will start to lower the vent until the LOWER LIMIT switch is closed or the UP/DOWN BUTTON is pressed again.

#### **UPPER LIMIT SWITCH**

When this limit switch is closed during the sleeve's upward motion, the sleeve motor will be switched off. This indicates the sleeve is in its full upright. At this instance the fan motor will automatically select HIGH SPEED. Furthermore, the FAN SPEED buttons and the delay off button will then become operational.

#### **LOWER LIMIT SWITCH**

When this limit switch is closed during the sleeve's downward motion, the sleeve motor will be switched off automatically. This indicates the sleeve is in its lowest position.

#### **LOCKOUT FUNCTION**

Pressing and holding the LOW button and the HIGH speed button for more than 0.5 seconds will select the clean function. ONCE THIS FUNCTION IS ACTIVATED, ALL

THE BUTTONS WILL BE DISABLED UNTIL THIS FUNCTION IS ENABLED BY AGAIN PRESSING AND HOLDING THE TWO SPEED BUTTONS FOR 0.5 SECONDS. This function will permit the cleaning of the unit without accidentally activating the unit.

### **INITIAL POWER UP**

On power up, the controller will not assume any status of the two limit switches. It is assumed that the sleeve motor will either be in its upright position or its lowest position. If the UPPER LIMIT switch is closed, the controller will automatically select the high fan speed and operate the fan at that speed.

On the other hand, if the lower limit switch is selected, the controller will switch off both the fan motor and the sleeve motor. ALL LED indicators will be switched off indicating the current status of the controller.

However, if both of the UPPER LIMIT and the LOWER LIMIT switches are off, pressing and releasing the UP/DOWN button will either raise or lower the vent depending on the mechanical set up of the vent, until either one of the limit switches are closed. Depending on which limit switch is closed, the vent will respond to the corresponding switch.

Furthermore, the controller will learn the current status of the limit switches and the direction of the sleeve motor. However if both limit switches are closed during any stage of operation, the controller will only be able to operate the sleeve motor.

### **FAILURE MODE, PCB PROGRAMMING**

The software for the vent is designed so that when the sleeve motor is travelling upwards, it will only look for the UPPER LIMIT switch. The software is designed this way so that the mechanical arrangement of the limit switch will not be a determining factor of the sleeve's operation.

However in the situation when the UPPER LIMIT switch fails to close due to either broken wire connection or malfunctioning of the limit switch, the sleeve motor will continue to operate until either the UP/DOWN is pressed again or the power is switched off.

To prevent the above situation from occurring, two timers are incorporated into the software. The sleeve will take 8 seconds to travel from its lowest position to its fully raised position; hence a 15 and a 30-second timer are used.

IF THE 15 SECOND TIMER TIMES OUT BEFORE THE CORRESPONDING LIMIT SWITCH, THE MICROPROCESSOR WILL ASSUME THE LIMIT SWITCH FAILS TO CLOSE. IT WILL ASSUME THE SLEEVE MOTOR IS NOW MOVING IN THE OPPOSITE DIRECTION THAN IT WAS BEFORE, DUE TO THE MECHANICAL SET UP OF THE SLEEVE, THEREFORE THE MICROPROCESSOR WILL TRY TO DETECT THE OTHER LIMIT SWITCH. IF THE 30 SECOND TIMER HAS TIMED OUT BEFORE THE LIMIT SWITCH COLOSES, THE MICROPROCESSOR WIL STOP THE SLEEVE MOTOR AND ALL OPERATION WILL BE DISABLED UNTIL A POWER RESET IS APPLIED.



# RV - RAISED VENT

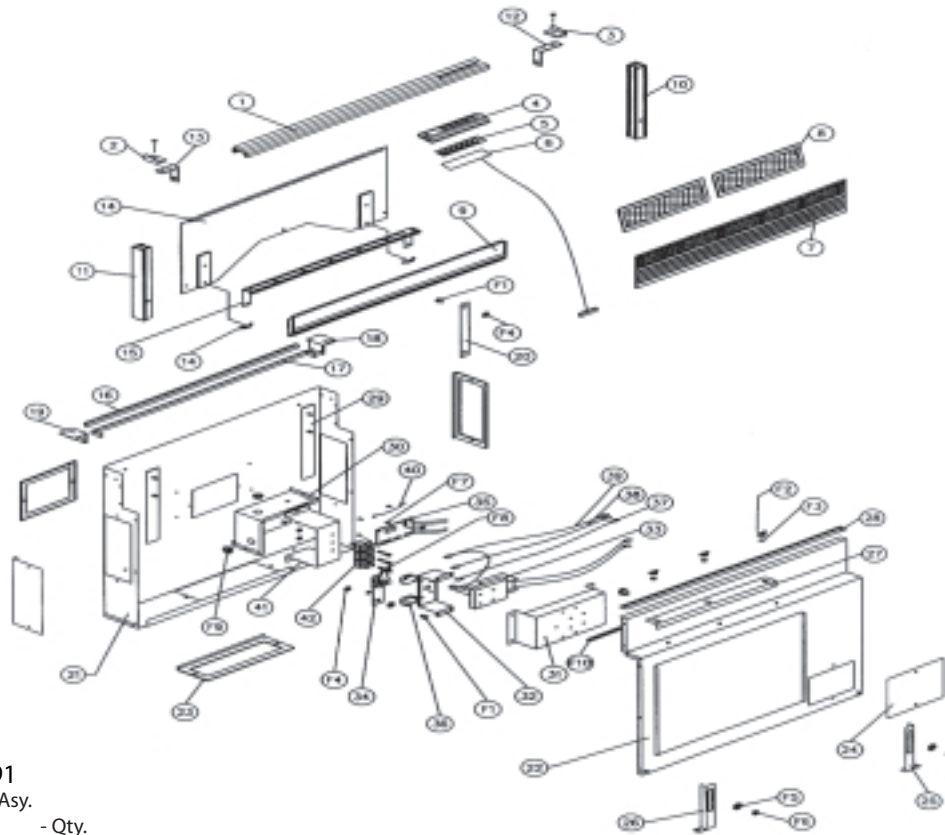

**\*Order As Kit, 700991**  
 700991, Control Board, Asy.  
 Part# - Description - Qty.  
 72881 - Control Board, 12a - 1  
 83538 - PCB Support, Nylon - 4

Ref.	Description	RV30	RV36	RV46	Ref.	Description	RV30	RV36	RV46
1	Top Cap	82740B/R/S	82741B/R/S	82742B/R/S	27	Adjustable Channel 26627	26627	26627	
2*	End Cap - Left	82997	82997	82997	28	Counter Seal	62232	62233	62234
3*	End Cap - Right	82996	82996	82996	29	Slide, RV Sleeve	82717	82717	82717
*	Colors A,B,R,C,S				30	Electrical Box Weldment	27447	27447	27447
4	Bezel	82754	82754	82754	31	Motor Mounting Box	26653	26653	26653
5	Keypad	82757	82757	82757	32	Limit Switch Mounting			
6	Keyboard, P.C.B.	82633	82633	82633		Bracket	26652	26652	26652
7	Grill	13081	13082	13083	33	Motor, Sleeve Drive	62198	62198	62198
*	G grill	82794	82795	82796	34	Drive Arm Weldment	82244	82244	82244
8	Filter	82766	82767	82768	35	Control Board, 12Amp	72881*	72881*	72881*
9	Sleeve Front	82737	82738	82739	36	Limit Switch	82713	82713	82713
*	Sleeve Front	82791	82792	82793	37	Red, Limit Switch Wire	14362	14362	14362
10	Sleeve Side	82762	82762	82762	38	Blue, Limit Switch Wire	14361	14361	14361
11	Sleeve Side	82762	82762	82762	39	White, Limit Switch Wire	14363	14363	14363
12	End Cap Angle - RH	82940	82940	82940	40	Ground Wire	12085	12085	12085
13	End Cap Angle - L H	82941	82941	82941	41	Terminal Strip Bracket	26043	26043	26043
14	Sleeve Rear Panel	26621	26622	26623	42	Terminal Strip	82143	82143	82143
15	Bracket, Filter Retainer	82182	82183	82184	F1	Drive Arm Stud	82243	82243	82243
16	Plenum Trim	82746	82747	82748	F2	Wing Nut, # 10-24	83035	83035	83035
17	Felt Wiper	62235	62236	62237	F3	Washer # 10	83008	83008	83008
18	Plenum Angle - RH	82753	82753	82753	F4	Spring Clip	83173	83173	83173
19	Plenum Angle - LH	82749	82749	82749	F5	Washer 1/4 - 20 Flat	83203	83203	83203
20	Sleeve Arm	82721	82721	82721	F6	Nut, Hex Keps 1/4-20	83049	83049	83049
21	Rear Plenum Weldment	27440	27441	27442	F7	PCB Support	83538	83538	83538
22	Plenum Front	27443	27444	27445	F8	Set Screw 1/4 - 28	83070	83070	83070
23	Plenum Duct Hole Cover	26626	26626	26626	F9	Bushing, Wire Protector	83056	83056	83056
24	Electrical Box Cover	26620	26620	26620	F10	Foam Tape	62238	62239	62240
25	Support Leg - RH	26521	26521	26521		5 Amp Fuse	62245	62245	62245
26	Support Leg - LH	26522	26522	26522	**Not Shown**	SleeveDrive Motor	76457	76457	76457
					**Not Shown**	Wire Harness	62634	62634	62634

86100 Board uses 62245- 5 amp Fuse - 72028 board uses 62886- 15 amp fuse

DACOR Technical Service

P.O. Box 6530 Diamond Bar, CA 91765 800-353-2267 - Fax: 909-612-1702



# RVC

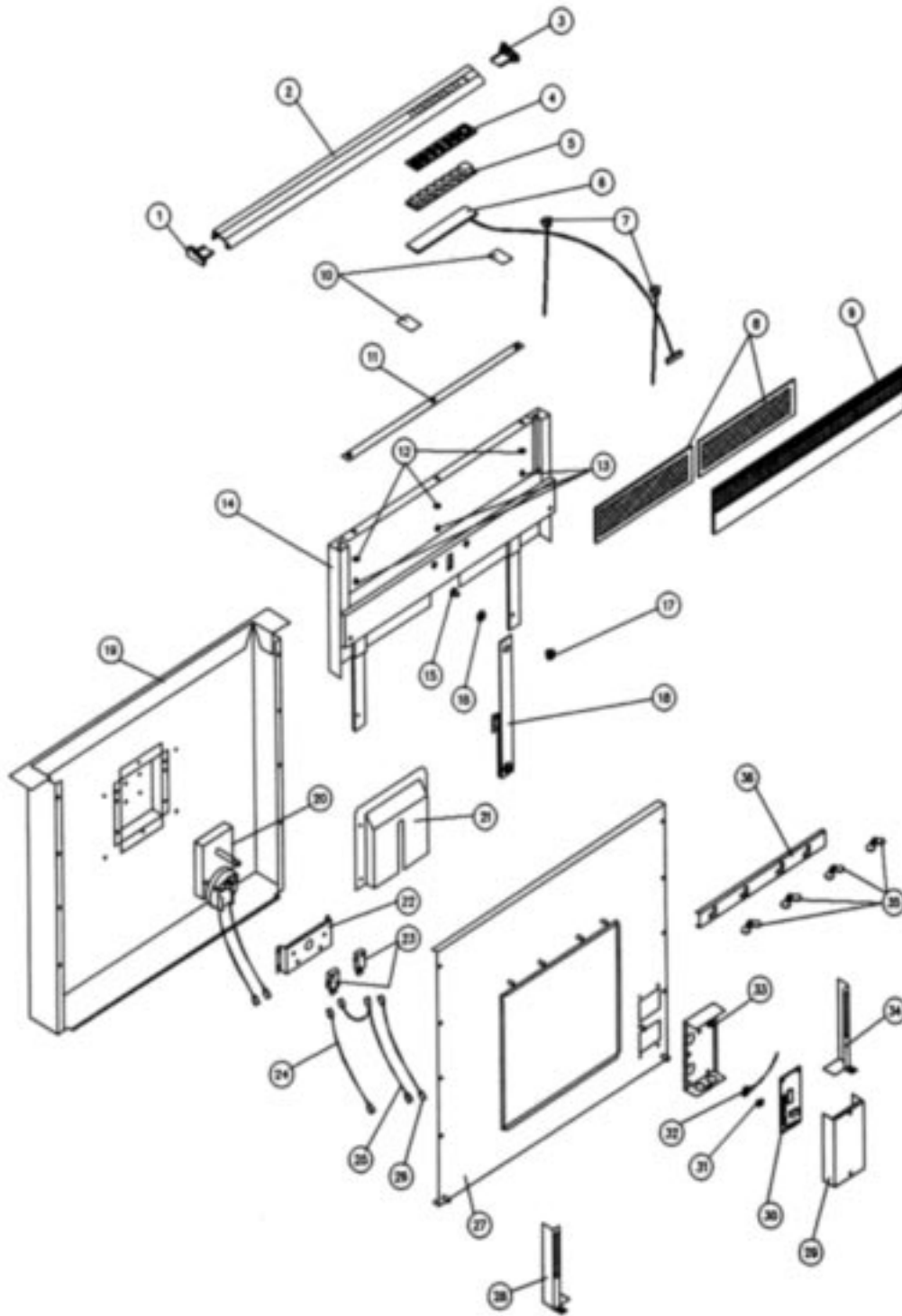

RAISED VENT WITH CABINET BLOWER - MODELS: RVC30 / RVC36 / RVC46

## RVC30, 36, 46

REF#	PART #	DESCRIPTION
1	82708A, B, W	LEFT END CAP
2	82705AS, B, WS	TOP CAP, 30" VENT
2	82706AS, BS, WS	TOP CAP, 36" VENT
2	82707AS, BS, WS	TOP CAP, 46" VENT
3	82709A, B, W	RIGHT END CAP
4	82710A, B, W	KEYPAD BEZEL
5	82711	KEYPAD
6	86347	CIRCUIT BOARD
7	83038	CABLE TIE
8	82766	FILTER - 30" VENT
8	82767	FILTER - 36" VENT
8	82768	FILTER - 46" VENT
9	82702	GRILL - 30" VENT
9	82703	GRILL - 36" VENT
9	82704	GRILL - 46" VENT
10	26516	CIRCUIT BOARD RETAINER
11	13227	TOP CAP RETAINING PLATE - 30" VENT
11	13228	TOP CAP RETAINING PLATE - 36" VENT
11	13229	TOP CAP RETAINING PLATE - 46" VENT
12	83008	#10 SAE WASHER
13	83532	SCREW, 8-32 X 1/4
14	86320	SLEEVE ASSEMBLY - 30" VENT
14	86321	SLEEVE ASSEMBLY - 36" VENT
14	86322	SLEEVE ASSEMBLY - 46" VENT
15	82723	UPPER ARM BUSHING
16	82726	UPPER BUSHING SPACER
17	83017	10-24 X 1/4 PHIL TRS
18	86323	SLEEVE DRIVE ARM ASSEMBLY
19	27375	REAR PLENUM ASSEMBLY - 30" VENT
19	27376	REAR PLENUM ASSEMBLY - 36" VENT
19	27377	REAR PLENUM ASSEMBLY - 46" VENT
20	13226	SLEEVE DRIVE MOTOR ASSEMBLY
21	82725	DRIVE MOTOR COVER
22	26502	LIMIT SWITCH MOUNTING BRACKET
23	82713	LIMIT SWITCH
24	14362	UPPER LIMIT SWITCH WIRE, RED
25	14363	LIMIT SWITCH COMMON, WHITE
26	14361	DOWN LIMIT SWITCH WIRE, BLUE
27	27381	PLENUM COVER WELDMENT - 30" VENT
27	27382	PLENUM COVER WELDMENT - 36" VENT
27	27383	PLENUM COVER WELDMENT - 46" VENT
28	26522	RVC VENT SUPPORT LEG, LEFT
29	26500	ELECTRONICS COVER BOX
30	86100	ELECTRONIC CONTROL
31	83009	10-24 KEPS NUT
32	12085	GROUND WIRE ASSEMBLY, GREEN
33	26501	ELECTRONICS BOX
34	26521	RVC VENT SUPPORT LEG, RIGHT
35	83035	10-24 WING NUT
36	26292	BLOWER MOUNTING CHANNEL
NOT SHOWN	83049	1/4 KEPS NUT FOR SUPPORT LEG ATTACHMENT

# RVR

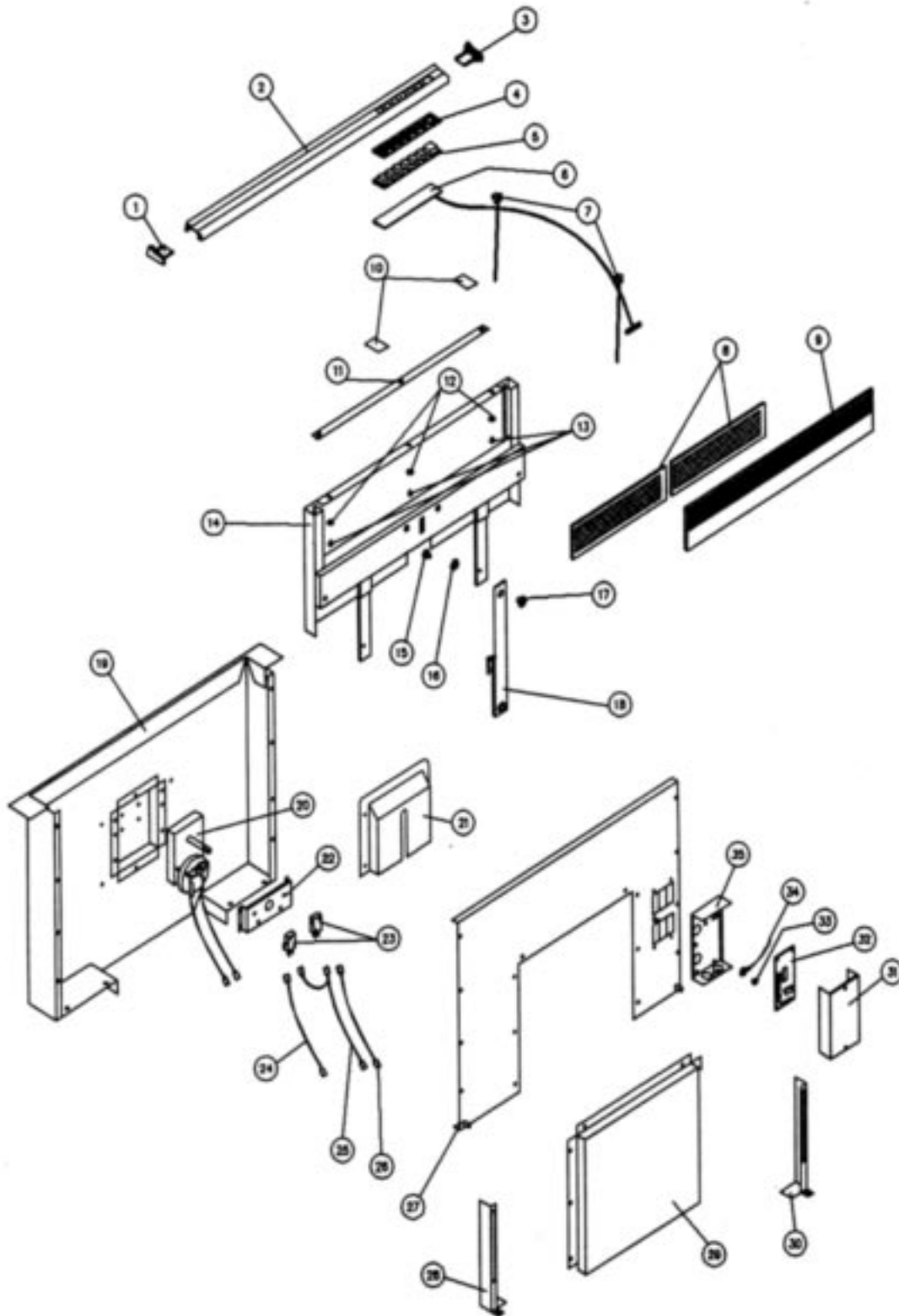

RAISED VENT WITH REMOTE BLOWER - MODELS: RVR30 / RVR36 / RVR46

## RVR30, 36, 46

REF#	PART #	DESCRIPTION
1	82708A, B, W	LEFT END CAP
2	82705AS, B, WS	TOP CAP, 30" VENT
2	82706AS, BS, WS	TOP CAP, 36" VENT
2	82707AS, BS, WS	TOP CAP, 46" VENT
3	82709A, B, W	RIGHT END CAP
4	82710A, B, W	KEYPAD BEZEL
5	82711	KEYPAD
6	86347	CIRCUIT BOARD
7	83038	CABLE TIE
8	82766	FILTER - 30" VENT
8	82767	FILTER - 36" VENT
8	82768	FILTER - 46" VENT
9	82702	GRILL - 30" VENT
9	82703	GRILL - 36" VENT
9	82704	GRILL - 46" VENT
10	26516	CIRCUIT BOARD RETAINER
11	13227	TOP CAP RETAINING PLATE - 30" VENT
11	13228	TOP CAP RETAINING PLATE - 36" VENT
11	13229	TOP CAP RETAINING PLATE - 46" VENT
12	83008	#10 SAE WASHER
13	83532	SCREW, 8-32 X 1/4
14	86320	SLEEVE ASSEMBLY - 30" VENT
14	86321	SLEEVE ASSEMBLY - 36" VENT
14	86322	SLEEVE ASSEMBLY - 46" VENT
15	82723	UPPER ARM BUSHING
16	82726	UPPER BUSHING SPACER
17	83017	10-24 X 1/4 PHIL TRS
18	86323	SLEEVE DRIVE ARM ASSEMBLY
19	27375	REAR PLENUM ASSEMBLY - 30" VENT
19	27376	REAR PLENUM ASSEMBLY - 36" VENT
19	27377	REAR PLENUM ASSEMBLY - 46" VENT
20	13226	SLEEVE DRIVE MOTOR ASSEMBLY
21	82725	DRIVE MOTOR COVER
22	26502	LIMIT SWITCH MOUNTING BRACKET
23	82713	LIMIT SWITCH
24	14362	UPPER LIMIT SWITCH WIRE, RED
25	14363	LIMIT SWITCH COMMON, WHITE
26	14361	DOWN LIMIT SWITCH WIRE, BLUE
27	27384	PLENUM COVER WELDMENT - 30" VENT
27	27385	PLENUM COVER WELDMENT - 36" VENT
27	27386	PLENUM COVER WELDMENT - 46" VENT
28	26524	RVR VENT SUPPORT LEG, LEFT
29	26513	DUCT ADAPTOR PLATE
30	26523	RVR VENT SUPPORT LEG, RIGHT
31	26500	ELECTRONICS BOX COVER
32	86100	ELECTRONIC CONTROL
33	83009	10-24 KEPS NUT
34	12085	GROUND WIRE ASSEMBLY, GREEN
35	26501	ELECTRONICS BOX
NOT SHOWN	83049	1/4-20 KEPS NUT

# RV

## WIRING OF RV SERIES RAISED VENTS TO BLOWERS

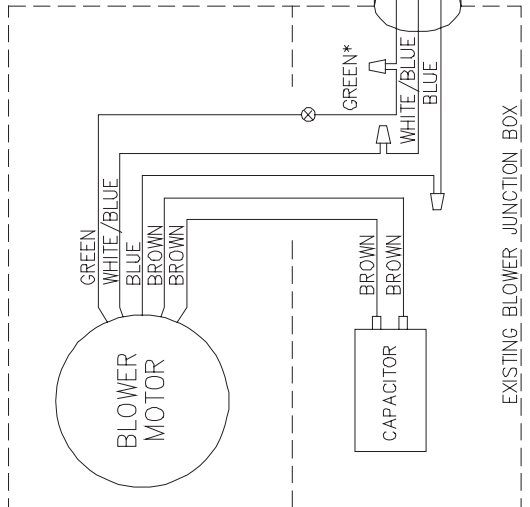
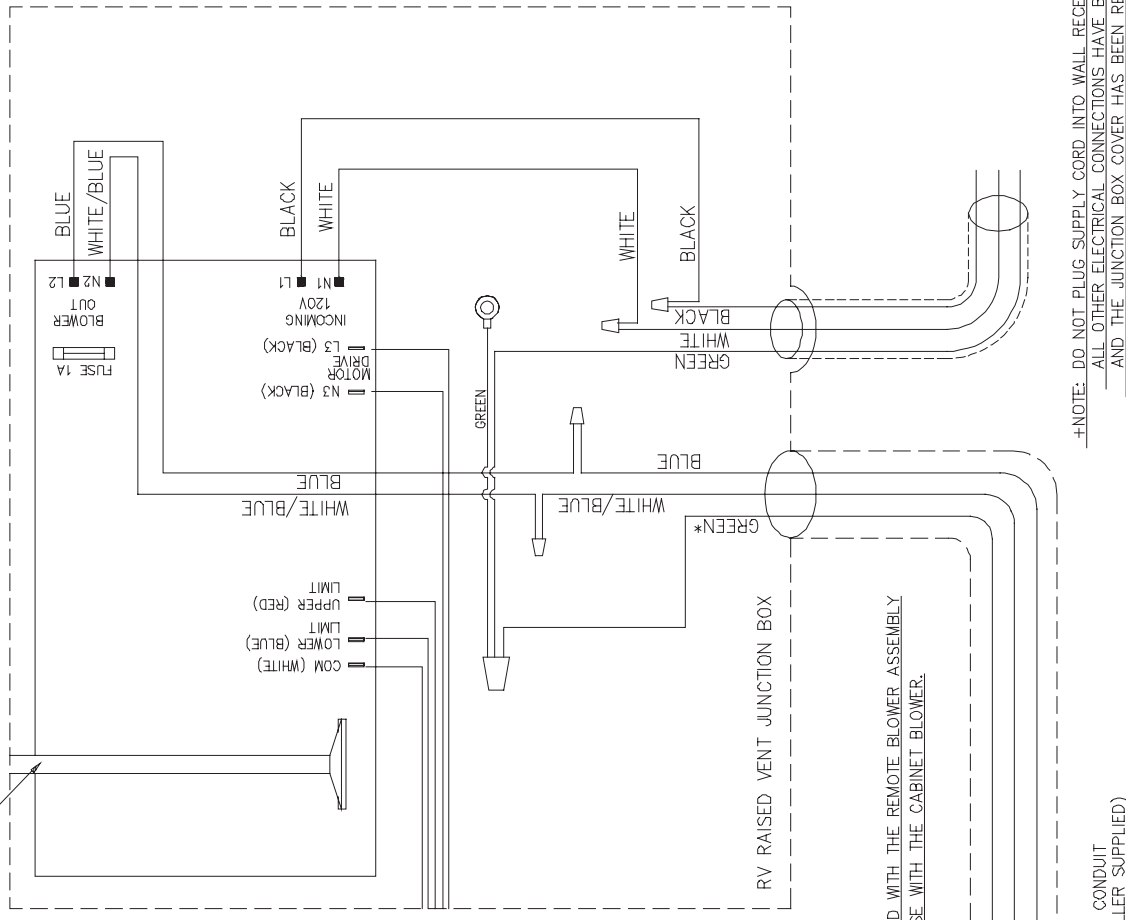
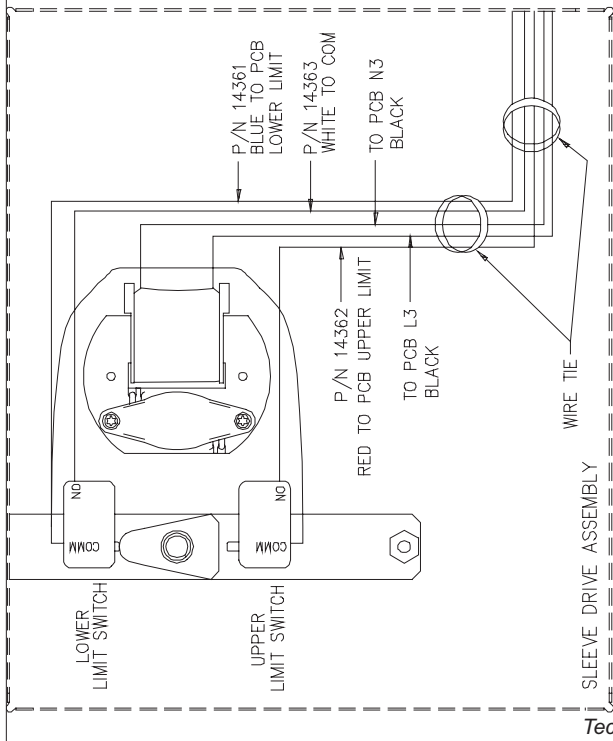

GREEN\* -- THIS WIRE IS USED WITH THE REMOTE BLOWER ASSEMBLY ONLY. DO NOT USE WITH THE CABINET BLOWER.

+NOTE: DO NOT PLUG SUPPLY CORD INTO WALL RECEPTACLE UNTIL ALL OTHER ELECTRICAL CONNECTIONS HAVE BEEN MADE AND THE JUNCTION BOX COVER HAS BEEN RE-INSTALLED.