

BAXI

User's Operating Instructions

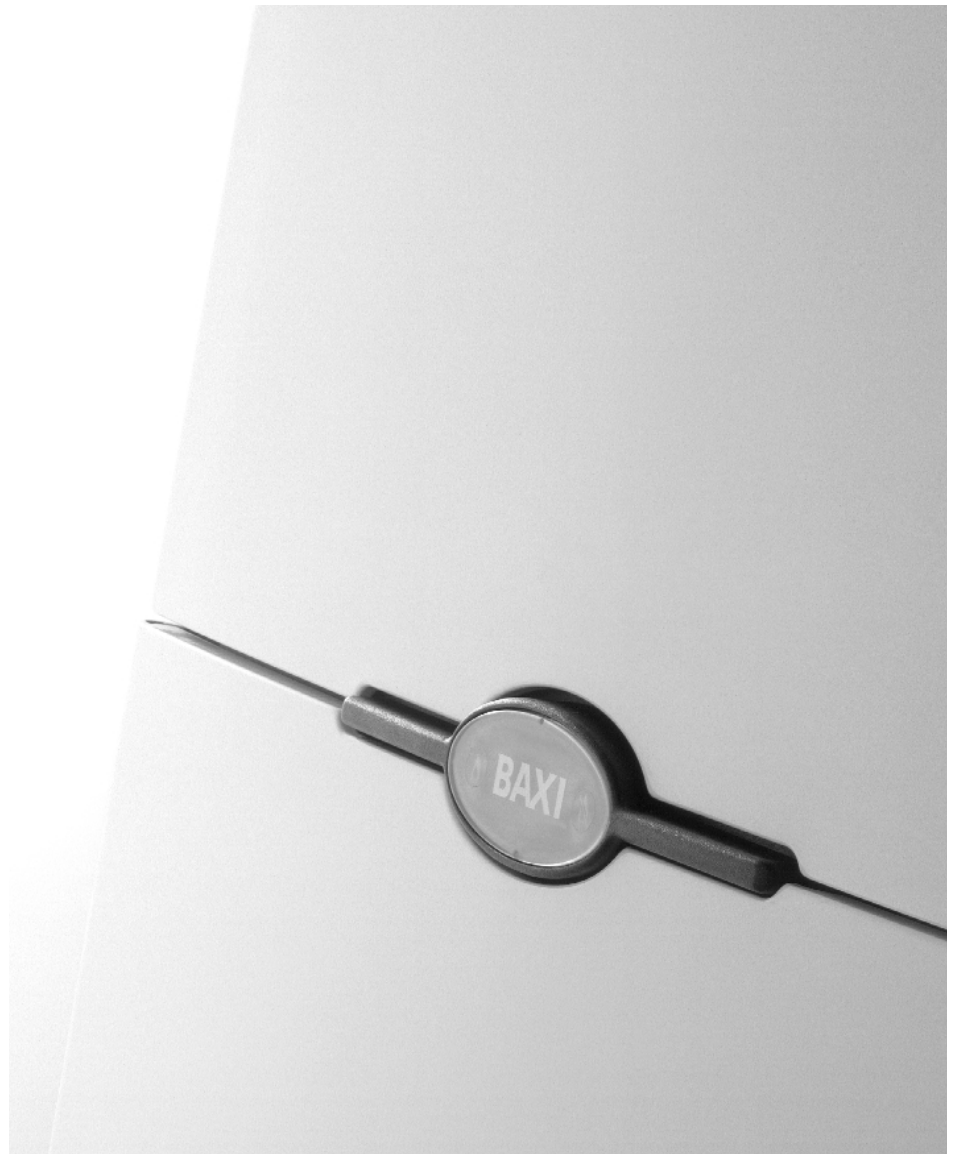

Baxi Combi 133 HE Plus Baxi Combi 100 HE Plus Baxi Combi 80 HE Plus

Gas Fired Wall Mounted Condensing
Combination Boiler

Please keep these instructions safe.
Should you move house, please hand
them over to the next occupier.

Natural Gas

Baxi Combi 133 HE Plus

G.C.N° 47 075 14

Baxi Combi 100 HE Plus

G.C.N° 47 075 15

Baxi Combi 80 HE Plus

G.C.N° 47 075 16

Baxi is one of the leading manufacturers of domestic heating products in the UK.

Our first priority is to give a high quality service to our customers. Quality is designed into every Baxi product - products which fulfil the demands and needs of customers, offering choice, efficiency and reliability.

To keep ahead of changing trends, we have made a commitment to develop new ideas using the latest technology - with the aim of continuing to make the products that customers want to buy.

Everyone who works at Baxi has a commitment to quality because we know that satisfied customers mean continued success.

We hope you get a satisfactory service from Baxi. If not, please let us know.

The boiler meets the requirements of Statutory Instrument "The Boiler (Efficiency) Regulations 1993 N° 3083" and is deemed to meet the requirements of Directive 92/42/EEC on the energy efficiency requirements for new hot water boilers fired with liquid or gaseous fuels:-

Type test for purpose of Regulation 5 certified by:
Notified Body 0086.

Product/Production certified by:
Notified Body 0086.
Ref: 86-BL-647

For GB/IE only.



Baxi is a BS-EN ISO 9001
Accredited Company

This product has an energy rating (A) on a scale of A to G.
For more information see www.boilers.org.uk. This is a certification mark.

1.0 Introduction

1.1 Introduction

1. Your Baxi Combi 133 - 100 - 80 HE Plus are gas fired, room sealed, powered flue condensing combination boilers, providing central heating for your home and mains fed domestic hot water. It is fully automatic and does not have a pilot light. Boiler frost protection and pump protection are an integral part of the appliance.
2. Due to the high efficiency and the resulting low flue gas temperature a white plume of condensate will be emitted from the flue outlet terminal. This will be particularly evident during periods of low outdoor temperatures.
3. The very high efficiency of these boilers also results in the flue gasses cooling to the point where part of their moisture content condenses inside the boiler, giving up further heat as it does so. The condensate is drained to a suitable disposal point through the plastic waste pipe at the bottom left of the boiler. This must not be modified or blocked.
4. Priority is given to the hot water mode - when a hot water tap is turned on the supply of heat to the central heating circuit is interrupted.

1.2 Operating the Boiler

1. The externally mounted Baxi Intellistat, integral Baxi 12 Hour Timer Kit or other type of clock should have been fitted in your system, together with heating controls. Full instructions on the use of these controls will have been supplied with them.
2. Hot water will always be available when a hot tap is opened.
3. Central heating will be available if the Summer/Winter switch is set to Winter and the timer (or other clock) is set correctly. It is also dependent on the setting of any room thermostats or thermostatic radiator valves. Refer also to Section 3.2 Protection & Precautions on Page 5.

To access the control panel, hinge down the lower door panel (Fig. 1).

When the boiler is in its standby state, the only visible light should be the Green 'Mains ON'.

NOTE: All Illustrations show the Combi 133 HE Plus unless otherwise stated.

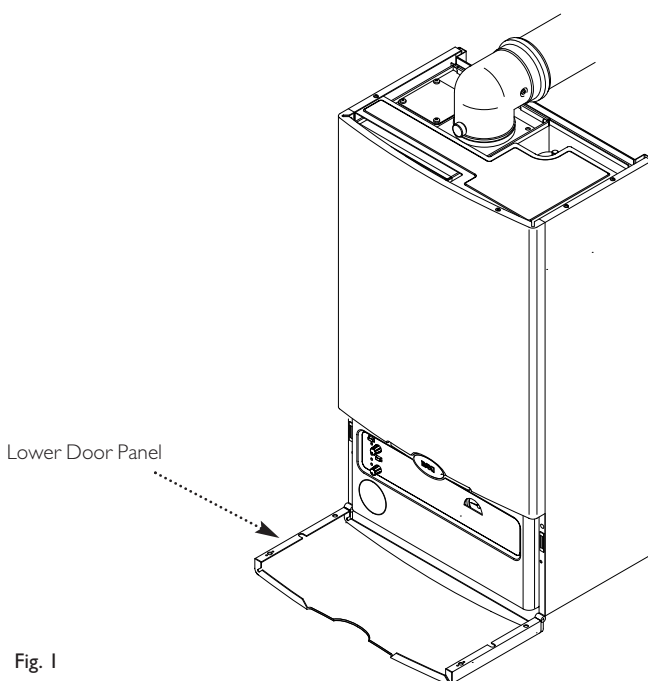

Fig. 1

2.0 Operating the Boiler

2.1 Temperature Control

Central Heating

The boiler will automatically achieve the optimum flow temperature for maximum comfort and efficiency.

1. However, in the case of the elderly, infirm or very young, a lower radiator surface temperature may be desirable. If so, the central heating flow temperature can be adjusted between approx 55 °C minimum and approx 82 °C maximum by turning the Central Heating Maximum Radiator Temperature Control Knob (Fig. 2).

2. The boiler will light automatically on demand and the Green 'Burner ON' light will be lit whilst water is being heated (Fig. 2).

3. Priority is given to domestic hot water. The boiler control system has an automatic time delay built in for central heating. It is normal that following a shutdown by the boiler thermostat, timer or other heating control, there is a delay of around 3 minutes, before re-lighting.

Domestic Hot Water

The boiler will automatically achieve the optimum flow temperature for maximum comfort and efficiency.

1. The temperature of the domestic hot water can be adjusted between approx 45 °C minimum and approx 55 °C maximum by turning the Domestic Hot Water Temperature Control Knob (Fig. 2).

2. The boiler will light automatically on demand. The Green 'Domestic Hot Water ON' light will be lit from the tap being opened until the tap is shut and water has been heated to the set temperature. The Green 'Burner ON' light will be lit whilst water is being heated. (Fig. 2).

Intelligent Pre-Heat: The boiler incorporates an intelligent pre-heat feature. This ensures that the domestic hot water to the tap is pre-heated only when the user required hot water the previous week. The pre-heat switches the boiler on for approximately 1 minute every 40 minutes when required. During the first week of operation from power on, no pre-heating will occur.

Summer/Winter Button

Summer setting (Button Out) - hot water will be provided when a tap or shower is turned on. Central heating will be off even if the Timer or other control is set to On.

Winter setting (Button In) - central heating will operate on demand or the hot water will be provided when a tap or shower is turned on (Fig. 2).

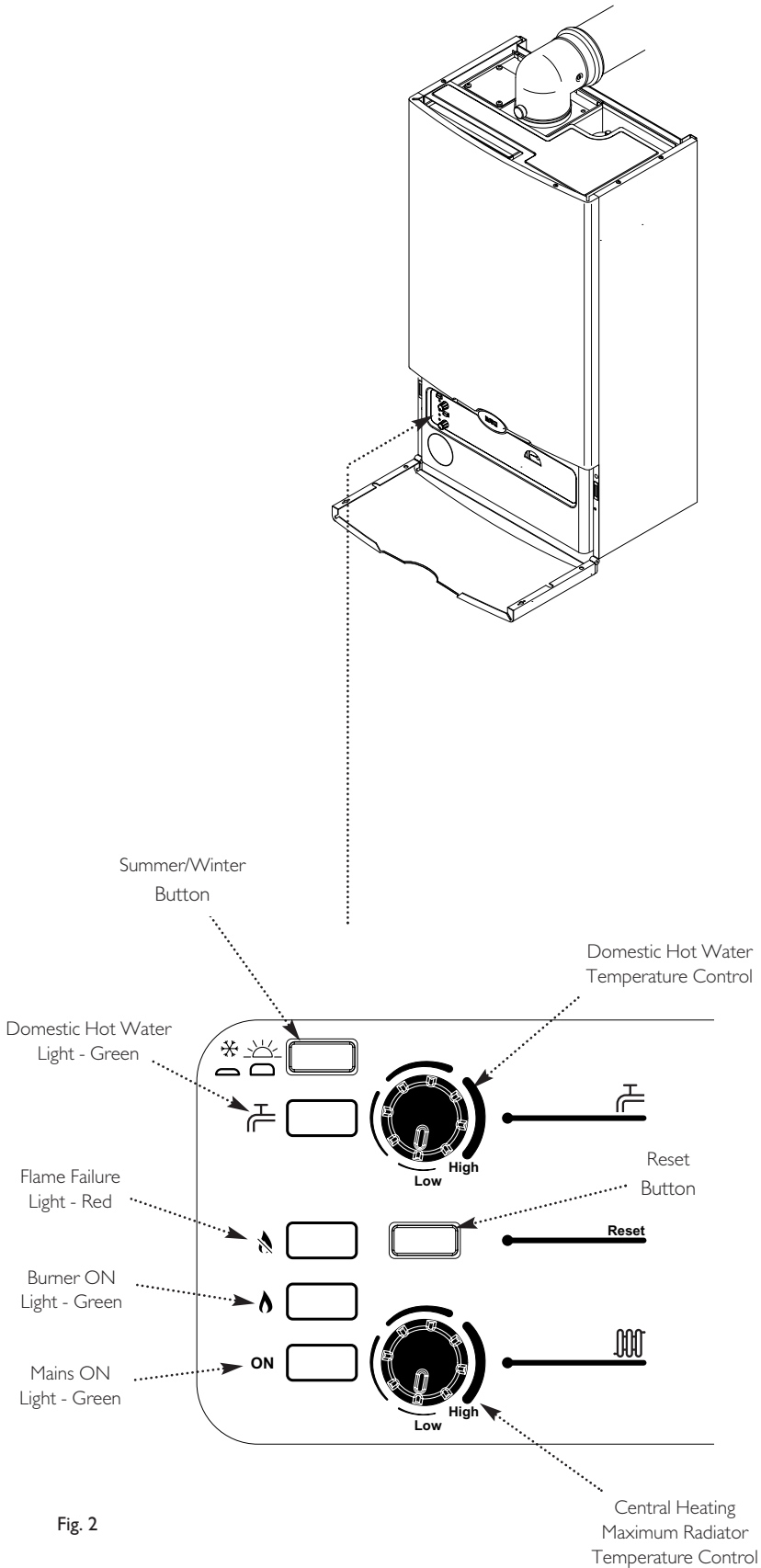

Fig. 2

3.0 Care of the Boiler

3.1 Central Heating System Pressure

1. The water pressure in the central heating system is indicated by the pressure gauge.
2. The normal operating pressure is in the range between 1 and 2.5 bar.
3. A pressure of 3 bar or greater indicates a fault. The safety pressure relief valve will operate at a pressure of 3 bar and very hot water or steam will be discharged through the pipe on the right hand side of the boiler, out of the property and usually into a nearby drain. It is important that a Competent Person is contacted as soon as possible.
4. If the pressure falls below 1 bar it may indicate a leak on the central heating system.

The system must be re-pressurised by a Competent Person.

3.2 Protection & Precautions

1. The boiler incorporates an integral frost protection feature that will operate in both Summer and Winter settings. If the boiler temperature falls below 4 °C, the boiler will fire until a temperature of 15 °C is reached.
2. If a system frost thermostat has been fitted (your Installer should have advised you), then to operate correctly and protect your system, the gas and electricity must be left on and the appliance set in the winter mode.
3. The boiler incorporates an integral pump protection feature which continually monitors the time since the pump last operated. To prevent seizure, the pump will be run for around 1 minute if it has not been run in the last 24 hours.

3.3 Cleaning the Outercase

The painted panels should be wiped with a damp cloth and then dried completely. **DO NOT USE ABRASIVE CLEANING AGENTS.**

3.4 Spare Parts

1. Any repairs to the boiler will usually be the responsibility of the Installer during the guarantee period after which spare parts may be obtained through approved Baxi stockists if required.
2. Quote the appliance name, model number and where possible the part number when ordering spares. A short parts list is included in the Installation and Servicing Instructions.

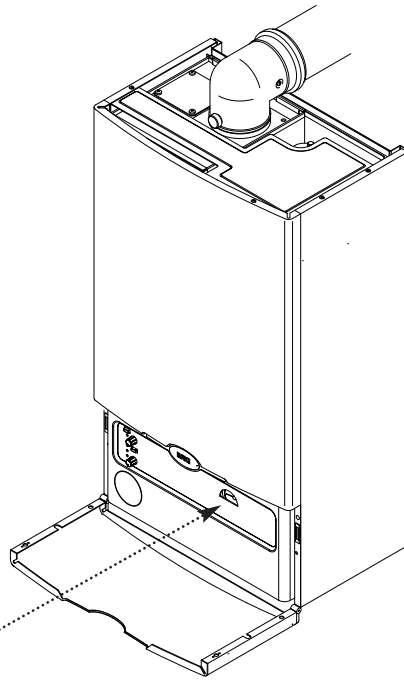

Fig. 3 Pressure Gauge

Refer to Page 10 for the definition of a **Competent Person**.

3.0 Care of the Boiler

3.5 Guarantee

1. Your Baxi Combi HE Plus Range is designed and produced to meet all the relevant Standards.
2. Baxi provide a 12 month guarantee on the boiler. The guarantee operates from the date installation is completed for the customer who is the original user.
3. To maximise the benefit from our guarantee we urge you to return the reply-paid guarantee registration.
4. This does not in any way prejudice your rights at Common Law. Such rights between the customer and the installer or supplier from whom the unit was purchased remain intact.

Any component or part which becomes defective during the guarantee period as a result of faulty workmanship or material whilst in normal use will be repaired or replaced free of charge.

3.6 Servicing your Appliance

For reasons of safety and economy your boiler should be serviced annually. Servicing must be performed by a competent person.

Refer to Page 10 for the definition of a **Competent Person**.

4.0 Safety Devices

4.1 Operation of Safety Devices

1. Your Baxi Combi HE Plus Range is fitted with safety devices which shut down the appliance if:

- the system overheats.
- the condensate drain is blocked.
- there is no gas to the boiler.

2. The flame failure light () will be either flashing or permanently illuminated and the boiler will need resetting (Fig. 4).

NOTE: In the case of persistent operation of the devices, turn off the boiler and consult your service engineer as an appliance or system fault is indicated.

4.2 Resetting (Fig. 4)

1. Check that the gas, water and electricity supplies to the appliance have not been inadvertently turned off.

2. Check the condensate drain outlet has not been blocked.

WARNING: The condensate outlet must not be blocked or modified.

3. Allow the boiler to cool if hot.

4. Hinge down the lower door panel.

5. Press the Reset Button.

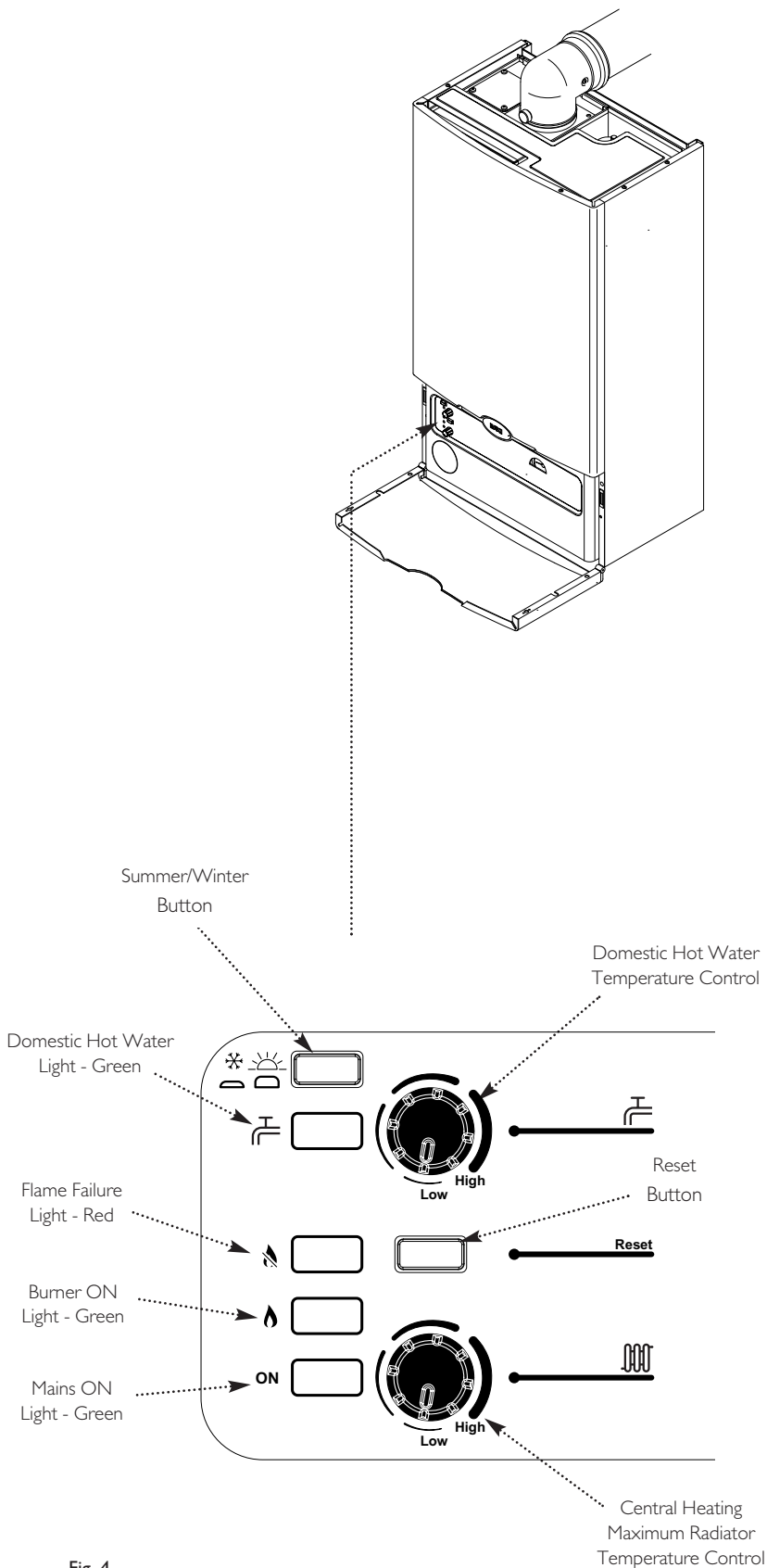

Fig. 4

5.0 Clearances

5.1 Clearances around the Boiler

1. The minimum clear spaces needed around the boiler measured from the casing are as follows:

Top	-	200mm	
Bottom	-	200mm	
Both sides	-	5mm	
Front	-	500mm	(For Servicing)
	-	5mm	(In Operation)

2. **These areas must not be obstructed in any way. Blocking the clearance spaces may result in the boiler overheating and damage may occur.**

3. The gas burning compartment of your boiler is completely sealed from the room in which it is fitted. Products from the combustion of gas are vented to the outside through the flue terminal which must be kept free from obstruction as this would interfere with the correct operation of the boiler.

4. **Where the appliance is installed in a cupboard or compartment no air vents are required.** The label affixed to the front of the boiler must not be removed. The information will be required by service engineers in the future. The compartment should be large enough to house the boiler and ancillary equipment only.

5. **IT SHOULD NOT BE USED AS A STORAGE CUPBOARD.**

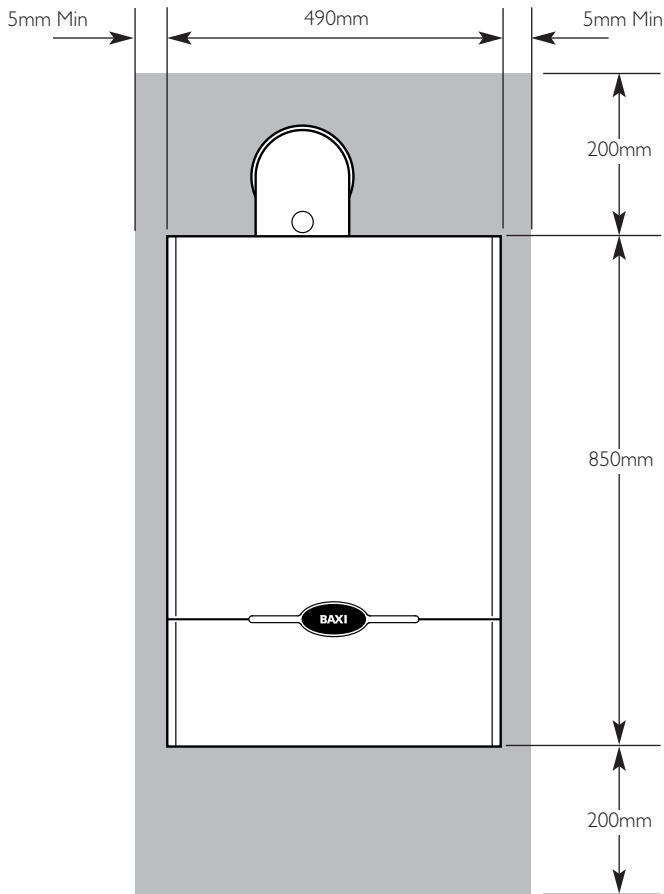

Fig. 5

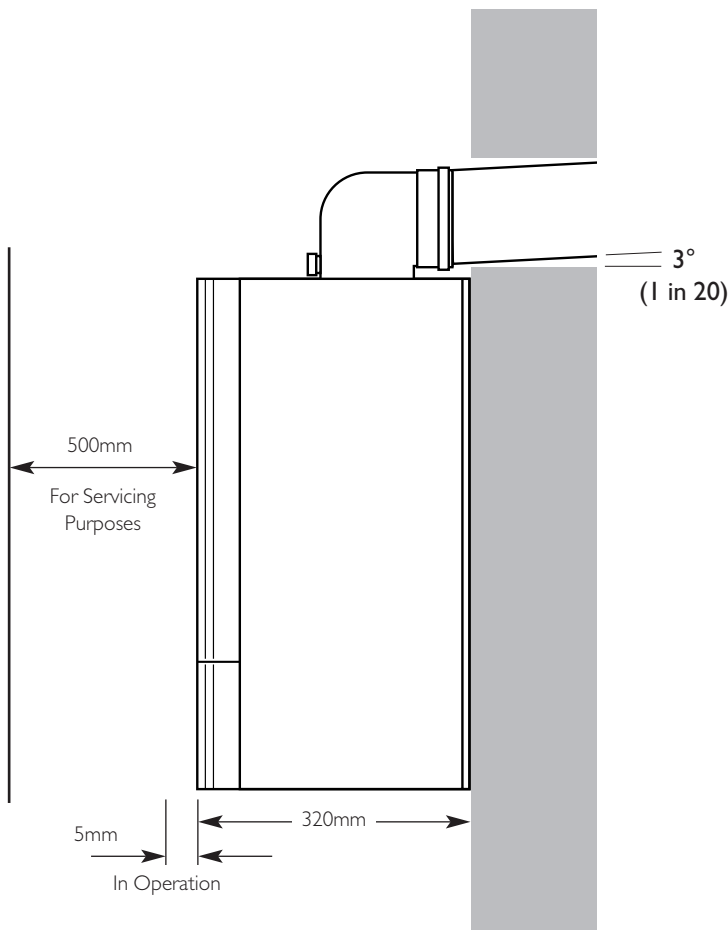

Fig. 6

Never Hang Any Items Over The Appliance

6.0 Fault Finding/Emergency

6.1 Check List

1. If a fault develops, or is suspected, call a Competent Person as soon as possible.
 2. Go through the following check list before you make contact.
 - a) Is the electricity supply on ?
 - c) Is the Red "Flame Failure" light illuminated ?
If the boiler fails to light or the boiler is running and the gas is turned off, the LED will start to flash red. Press the reset button for a minimum of 1 and a maximum of 3 seconds (Do Not use excessive pressure), the LED will stop flashing and the boiler will attempt to relight. If the button is pressed for more than 5 seconds the LED will flash red rapidly and will need to be reset again. If pressed for less than 1 second, the boiler will not reset. If the boiler will not light it should be attended to by a competent person.
 - d) Is the gas supply on ?
 - e) Is the mains water supply turned on ?
 - f) Are the boiler temperature controls set high enough ?
 - g) Is the time clock (if fitted) calling for central heating ?
 - h) Is the room thermostat (if fitted) set high enough ?
 - i) Are the radiator valves open ?
-

6.2 IN AN EMERGENCY

If a water or gas leak occurs or is suspected, the boiler can be isolated at the inlet valves as follows;

1. Turn off the electrical supply.
 2. The isolating valves are positioned under the boiler and can be closed using either a flat headed screwdriver or a 7mm open ended spanner across the flats.
 3. Turn the gas tap clockwise to the stop position to isolate the gas supply at the boiler.
 4. To isolate the water system, close the four valves fully by turning clockwise.
 5. Call a Competent Person as soon as possible.
-

7.0 Legislation

IMPORTANT - Installation, Commissioning, Service & Repair

This appliance must be installed in accordance with the manufacturer's instructions and the regulations in force. Read the instructions fully before installing or using the appliance.

In GB, this must be carried out by a competent person as stated in the Gas Safety (Installation & Use) Regulations.

Definition of competence: A person who works for a CORGI registered company and holding current certificates in the relevant ACS modules, or valid ACoP equivalents, is deemed competent.

In IE, this must be carried out by a competent person as stated in I.S. 813 "Domestic Gas Installations".

Lifting - This product should be lifted and handled by two people. Stooping should be avoided and protective equipment worn where necessary. Carrying & lifting equipment should be used as required, e.g. when installing in a loft space.

The addition of anything that may interfere with the normal operation of the appliance without express written permission from the manufacturer or his agent could invalidate the appliance warranty. In GB this could also infringe the Gas Safety (Installation and Use) Regulations.

Warning - Check the information on the data plate is compatible with local supply conditions.

"Benchmark" Installation, Commissioning and Service Record Log Book

Please ensure that your installer has completed the Installation and Commissioning sections of the Log Book and hands the Log Book over. The details of the Log Book will be required in the event of any warranty work. Keep the Log Book in a safe place and ensure that the relevant sections are completed at each subsequent regular service visit.

All CORGI registered installers carry a CORGI identification card and have a registration number. Both should be recorded in your boiler Log Book. You can check your installer is registered by telephoning +44 (0)1256 372300 or writing to:-

1 Elmwood,
Chineham Business Park,
Crockford Lane,
Basingstoke. RG24 8WG

In GB the following Codes of Practice apply:

STANDARD	SCOPE
B.S. 6891	Gas Installation.
B.S. 5440: Pt 1	Flues.
B.S. 5440: Pt 2	Air Supply.
B.S. 5546	Installation of hot water supplies for domestic purposes.
B.S. 7074	Expansion vessels and ancillary equipment for sealed water systems.
B.S. 5449: Pt 1	Forced circulation hot water systems.
B.S. 6798	Installation of gas fired hot water boilers.
B.S. 7593	Treatment of water in domestic hot water central heating systems.

7.1 Safe Installation

1. The appliance is suitable only for installation in GB and IE and should be installed in accordance with the rules in force.

In GB, the installation must be carried out by a CORGI Registered Installer. It must be carried out in accordance with the relevant requirements of:

- The **GAS SAFETY** (Installation and Use) **REGULATIONS**.
- The appropriate **BUILDING REGULATIONS** either the Building Regulations, The Building Regulations (Scotland), Building Regulations (Northern Ireland).
- The **WATER FITTINGS REGULATIONS OR WATER BYELAWS** in Scotland.
- The current **I.E.E. WIRING REGULATIONS**.
- Where no specific instructions are given, reference should be made to the relevant **BRITISH STANDARD CODES OF PRACTICE**. Reference should also be made to **BRITISH GAS GUIDANCE NOTES FOR THE INSTALLATION OF DOMESTIC GAS CONDENSING BOILERS**.

In IE, the installation must be carried out by a competent person and installed in accordance with the current edition of:

- **I.S.813 "DOMESTIC GAS INSTALLATIONS"**.
- The current **BUILDING REGULATIONS**.
- Reference should also be made to the current **ETCI** rules for electrical installation.

2. **This appliance must be installed in accordance with the manufacturer's instructions and the rules in force, and only used in a suitably ventilated location.**

3. **Read the instructions before installing or using this appliance.**

4. Any purpose provided ventilation should be checked periodically to ensure that it is free from obstruction.

7.2 Electricity Supply

1. **THIS APPLIANCE MUST BE EARTHED.**

2. A standard 230V ~ 50Hz supply is required. The appliance must be protected by a 3 amp fuse.

In IE:

STANDARD	SCOPE
I.S. 813	Domestic Gas Installations.
The following BS standards give valuable additional information	
B.S. 5546	Installation of hot water supplies for domestic purposes.
B.S. 7074	Expansion vessels and ancillary equipment for sealed water systems.
B.S. 5449	Forced circulation hot water systems.
B.S. 7593	Treatment of water in domestic hot water central heating systems.

When contacting Baxi Potterton please have the following information to hand:

Appliance Name
Model Number
Serial Number

A label giving these details is situated on the rear of the lower door panel attached to the users operating instruction label.

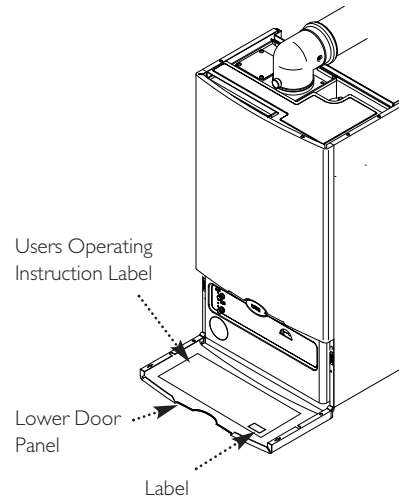

BAXI POTTERTON

A Trading Division of Baxi Heating UK Ltd
Browndge Road Bamber Bridge Preston Lancashire PR5 6UP
After Sales Service 08706 096 096 Technical Enquiries 08706 049 049
Website www.baxi.co.uk

A BAXI GROUP company

Comp N° 5109930 - Iss 1 - 04/04