



AutoDome Modular Camera System

VG4-200, VG4-300, and VG4-500i Series



BOSCH

en User's Manual

Preface

This guide describes how to control a VG4-200, VG4-300, and a VG4-500i Series AutoDome using a keyboard (Bosch or Pelco® brand keyboards) or via a TCP/IP connection.

Audience

This manual is intended for operators who are familiar with CCTV terms and configurations. Appendix A, on page 69, is a "tear-out" section for quick reference of User Commands.

Document Conventions

Convention	Meaning
Bold	Denotes a part, item, or assembly.
<i>Italic</i>	Denotes a reference to another paragraph, figure or table.
<u>Underline</u>	Used to emphasize a point.
Courier	Used to denote an item that is selected or must be typed exactly.

Symbols

You may encounter these symbols within the document. Explanatory text accompanies each symbol, which provides additional information detailing the operation or highlighting safety information.



NOTICE! Notices inform you of essential but non-critical information. Read these messages carefully as any directions or instructions contained therein can help you avoid making mistakes.

CAUTION! Cautionary messages provide critical information that help you reduce the chance of losing data or damaging the system. Please heed these messages.



WARNING! Warnings highlight information, that if overlooked may cause damage to the system or result in personal injury. Take warnings seriously.

Customer Support and Service

If this unit needs service, contact the nearest Bosch Security Systems Service Center for authorization to return and shipping instructions.

Service Centers

USA

Phone: 800-366-2283 or 585-340-4162

Fax: 800-366-1329

Email: cctv.repair@us.bosch.com

Technical Support

Phone: 800-326-1450

Email: technical.support@us.bosch.com

CCTV Spare Parts

Phone: 800-894-5215 or 408-957-3065

Fax: 408-935-5938

Email: BoschCCTVparts@ca.slr.com

Canada

Phone: 514-738-2434

Fax: 514-738-8480

Europe, Middle East & Asia Pacific Region

Phone: 44 (0) 1495 274558

Fax: 44 (0) 1495 274280

Email: rmahelpdesk@solectron.com

For additional information, see www.boschsecurity.com

Related Publications

Refer to the latest Bosch Security Systems Databook for the most up-to-date datasheets. To obtain a copy of the Databook, please contact your local Bosch representative.

You can also visit the Bosch Security Systems World Wide Web site at:

<http://www.boschsecurity.com> to view a current listings of our publications.

Table of Contents

1	Getting Started	3
1.1	Powering On	3
1.2	Establishing AutoDome Control	3
1.2.1	Basic Keyboard Operation	3
1.2.2	Keyboard Commands	4
1.3	Setting the Camera Address	4
1.3.1	FastAddress	4
1.4	Setting Passwords	5
1.4.1	Special Passwords	5
2	On-Screen Display Menu Navigation	7
2.1	Setup Menu	7
2.2	Camera Setup Menu	9
2.3	Lens Setup	11
2.4	PTZ Setup Menu	12
2.5	Display Setup Menu	14
2.6	Communication Setup Menu	15
2.7	Alarm I/O Setup	16
2.8	Rule Setup Menu	18
2.9	Language Menu	20
2.10	Advanced Feature Setup Menu (available with Series 500i only)	21
2.11	Diagnostics Menu	22
3	Common AutoDome User Commands (unlocked)	23
3.1	Setting AutoPan Mode	23
3.2	Setting Preset Shots	23
3.3	Configuring Preposition Tours	23
3.4	Programming the Inactivity Operation	24
3.5	Recording Tours	24
4	Pelco® Protocol Mode	25
4.1	Hardware Configuration	25
4.2	Address Guidelines	26
4.3	Pelco Keyboard Commands	26
4.3.1	Special Preset Commands	26
5	Pelco On-Screen Menus	27
5.1	Setup Menu	27
5.1.1	Command Lock (locked)	28
5.1.2	Bosch Menu (locked)	28
5.1.3	PTZ Setup (unlocked)	30
5.1.4	Other Menus	31

6	Keyboard Commands by Number	33
<hr/>		
7	Advanced Features	35
7.1	Alarm Rules	35
7.2	AutoTrack	37
7.3	Privacy Masking	37
7.4	Virtual Masking	37
7.5	Motion Detection with Region of Interest	37
7.6	Image Stabilization and Crop Video	38
7.7	Pre-position Tour	38
<hr/>		
8	Configuring and Using the IP AutoDome	39
8.1	Overview of Features	39
8.2	System Requirements	40
8.3	Connecting the IP AutoDome to the PC	40
8.4	Configuring the IP Camera	41
8.4.1	Installing the Required Software	42
8.4.2	Changing the Network Settings	42
8.5	Viewing Live Images and Controlling the AutoDome PTZ	43
8.5.1	Establishing a Connection	43
8.5.2	Configuring Data Streams	44
8.5.3	Controlling Camera Operations	44
8.5.4	Entering a Keyboard Control Command	46
<hr/>		
9	Troubleshooting Guide	49
<hr/>		
10	Glossary of CCTV Terms	53
<hr/>		
	Index	63
<hr/>		
A	User Commands by Number	69

1 Getting Started

Install and wire the AutoDome according to the Bosch *AutoDome Modular Camera System Installation Manual*. A typical system includes a keyboard, matrix switcher, monitor, and appropriate wiring connections. Please refer to the individual product manuals for complete installation and setup instructions for each of the system components.

1.1 Powering On

When you turn the AutoDome power on there is a ten (10) second pause before the dome starts its *homing phase*. During the homing phase the camera pans left and right and tilts up and down. It also adjusts the lens focus. The entire homing phase lasts approximately 40 seconds and ends with a splash screen.

1.2 Establishing AutoDome Control

The most common ways to interface with the AutoDome are:

- Using a keyboard and on-screen display (OSD) menus. This method is the most common and is covered in this manual.
- Using the AutoDome Configuration Tool software running on a PC with Bilinx or the RS-232/485 communication protocol. Refer to the *CTFID User Guide* for instructions.
- Using a PC-based graphical user interface (GUI) such as the Bosch DiBos 8 software. Refer to the *DiBos 8 User Guide* for instructions.
- Using the Bosch IP Web interface included with the IP Communications Module.

1.2.1 Basic Keyboard Operation

The following tables summarize the basic operations for a standard keyboard and the functions available to control an AutoDome camera.

Typical Keyboard Features	Usage
Function Keys	Selects a specific control setting.
Number Keys	Inputs a number from 0 to 9.
Camera Key	Selects a camera number.
Enter Key	Inputs a selection.
Focus Key	Sets the lens focus or makes a menu selection in OSD mode.
Iris Key	Sets the lens iris setting or makes a menu selection in OSD mode.
Key LEDs	Indicates an active key.
LCD	Displays the current status.
Joystick	Controls a pan/tilt/zoom (PTZ) AutoDome camera.

Table 1.1 Typical Keyboard Functions

Dome Operation	How to control
To Pan Side to Side	Move the joystick left or right.
To Tilt Up and Down	Move the joystick forward and back.
To Zoom In	Twist the joystick clockwise.
To Zoom Out	Twist the joystick counterclockwise.

Table 1.2 Typical Keyboard Controls for an AutoDome Camera

1.2.2 Keyboard Commands

Keyboard control commands are composed of a sequence of three (3) inputs with the following convention: 1) a **Function** key + 2) a **Command** number key(s) + 3) the **Enter** key.

- Depending on the type of keyboard, the control function keys are labeled:
ON or **AUX ON**
OFF or **AUX OFF**
SET or **SET SHOT**
SHOT or **SHOW SHOT**



NOTICE! The convention used for control key commands in this manual is **ON**, **OFF**, **SET**, and **SHOT**. Refer to your keyboard manual for the key naming conventions.

- Command numbers range from 1 to 999. See *Chapter 6: Keyboard Commands by Number* for a complete list of keyboard commands.
- The **Enter** key can also be labeled with the ↵ symbol.

For example, the keyboard command to make the AutoDome pan 360° continuously is:

ON-1-ENTER

Press the **ON** key, then press the number **1** key, and then press **ENTER**.

1.3 Setting the Camera Address

Once the AutoDome power is turned on and homing is complete, you must set the camera address. You may also want to assign a password and customize some of the AutoDome default settings.



NOTICE! You do not need to set a camera address if using Bilinx or Ethernet communication. See the *AutoDome Installation Manual* to configure an AutoDome for Bilinx or Ethernet operation.

1.3.1 FastAddress

FastAddress is an AutoDome feature that allows you to set or change a camera address using the keyboard and on-screen menus.

There are three (3) **FastAddress** commands:

- **ON-999-ENTER**: Displays and programs all cameras without an address in the system.



NOTICE! If a keyboard is set to a camera number that already has an address, that camera also responds to this command.

- **ON-998-ENTER**: Displays and programs all cameras with or without an address in the system.
- **ON-997-ENTER**: Displays the current address status of all cameras in the system simultaneously.

To set an address to a camera without an address:

1. Select the camera number you want to **FastAddress**. The system displays the camera number on the keyboard and the image on the corresponding monitor.
2. Press **#-ENTER** (where # is the camera number without an address).
3. Press **ON-999-ENTER** to invoke an on-screen display of cameras on the system without an address.

4. Follow the on-screen instructions. You receive an on-screen confirmation when the **FastAddress** is complete.

To change or clear an address to a camera with an address:

1. Select the camera number you want to **FastAddress**. The system displays the camera number on the keyboard and the image on the corresponding monitor.
2. Press **#-ENTER** (where # is the camera number with an address).
3. Press **ON-998-ENTER** to invoke an on-screen display of all cameras on the system, with or without an address.
4. Follow the on screen instructions. You receive an on-screen confirmation when the **FastAddress** is complete.



NOTICE! **FastAddress** is stored in nonvolatile memory and does not change if the power is turned off or if the default settings are restored.

1.4 Setting Passwords

Passwords are used to control access to locked command menus. Unlocked commands are available to all users. Passwords are four (4) digits in length.

1.4.1 Special Passwords

Password	Security Level
0000 (default)	Enables security and requires a user to enter the unlock command OFF-90-ENTER before invoking a locked command.
9999	Disables all security and allows all users to access locked commands.

To set or change a password (locked command):

1. Press **OFF-90-ENTER** to turn off the command lock.
2. Press **SET-802-ENTER** to access the password menu.
3. Tilt the joystick up or down to choose a number. Tilt the joystick right to move to the next number position.
4. Follow the on-screen instructions and save the password. You receive an on-screen confirmation.

2 On-Screen Display Menu Navigation

The AutoDome is programmed through the on-screen display (OSD) menus. To access the **OSD** menus, you must open the main **Setup Menu**.

Menu items marked with an * are default settings, unless otherwise noted.



NOTICE! After a period of 4.5 minutes of inactivity, a menu times-out and exits without warning. Some unsaved settings in the current menu can be lost.

2.1 Setup Menu

The main **Setup Menu** provides access to all programmable AutoDome settings. It is a locked menu that requires the user to turn off the command lock.

To open the main Setup Menu (locked command):

1. Press **OFF-90-ENTER** to turn off the command lock.
2. Press **ON-46-ENTER** to access the **Main Menu**.
3. Use the joystick to highlight a menu item.
4. Press **Focus/Iris** to open a menu.
5. Follow the on-screen instructions.



NOTICE! The AutoDome displays only those menus applicable to the AutoDome Series configuration. Use the joystick to navigate through the menu and the **Focus/Iris** keys to make a selection.

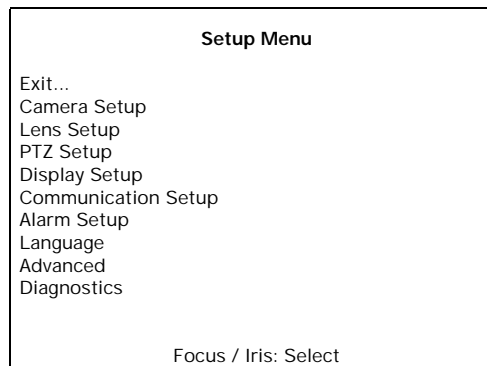

Setup Menu Choices:

Menu	Description
Exit	Exits the menu.
Camera Setup	Accesses adjustable camera settings such as: white balance, gain, sharpness, sync, line lock, backlight, shutter, and night mode.
Lens Setup	Accesses adjustable lens settings such as: focus, iris, zoom speed, and digital zoom.
PTZ Setup	Accesses adjustable pan/tilt/zoom (PTZ) settings such as: Autopan, tours, PTZ speed, inactivity period, AutoPivot, and tilt limits.
Display Setup	Accesses adjustable display settings such as: OSD, sector blanking, and privacy masking.
Communication Setup	Accesses communication settings such as: AutoBaud and Bilinx.
Alarm Setup	Accesses the alarm settings such as: inputs, outputs, and rules (not available with 200 Series models).
Language	Displays the language.
Advanced	Accesses the advanced features menu including Stabilization, Crop Video, Camera Height, and Virtual Masking (only available on 500i Series models).
Diagnostics	Displays the status of diagnostic events.



NOTICE! To select the **Exit Menu** item from anywhere in the current menu, use the Zoom command.

2.2 Camera Setup Menu

The **Camera Setup Menu** provides access to camera settings that can be changed or customized. Menu items with an * are the default settings.

Camera Setup	
Exit...	
* White Bal:	EXT ATW
* Gain Control:	AUTO
* Max. Gain Level:	6
* Sharpness	6
* Synch Mode:	Internal
* Line Lock Delay:	0
* Backlight Comp:	OFF
* Shutter Mode:	Auto SensUP
* Shutter:	1/60
* Auto SensUP Max:	15x
* Night Mode:	AUTO
* Night Mode Color:	OFF
* Night Mode Threshold:	30
* Pre-Comp	1
Restore Defaults...	
* = Factory Setting	
Focus / Iris: Select	

Camera Setup Menu Choices:

Menu	Description	Sub-menu / Description	Default Setting
Exit	Exits the menu.		
White Balance	Maintains proper color reproduction as the color temperature of a scene changes. For example, from daylight to fluorescent lighting.	Extended ATW: Adjusts camera color using extended range. ATW: Adjusts camera color constantly. Indoor W.B.: Optimizes camera color for typical indoor conditions. Outdoor W.B.: Optimizes camera color for typical outdoor conditions. AWB Hold: Sets the camera's color settings for the current scene.	Extended ATW
Gain Control	Electronically brightens darker scenes which may cause graininess in low light scenes.	Auto or OFF	AUTO
Max. Gain Level	Adjusts the maximum gain level that the gain control adjusts to when set to AUTO .	Sliding scale: – (1 to 6) +	6
Sharpness	Adjusts the sharpness level of the picture.	Sliding scale: – (1 to 16) +	6
Synch Mode	Sets the type of synchronization mode for the camera.	INTERNAL: Synchronizes camera to an internal crystal. This choice is recommended if there is noise on the power line. LINE LOCK: Synchronizes camera to AC power. This choice eliminates picture roll in multi-camera systems.	INTERNAL
Line Lock Delay	Optimizes the LINE LOCK mode to eliminate picture roll in multiphase power applications.	Sliding scale: – (0° to 359°) +	0°

Menu	Description	Sub-menu / Description	Default Setting
Backlight Comp	Improves image quality when the background illumination level is high.	ON or OFF	OFF
Shutter Mode:	Turns Auto SensUP on or off.	Auto SensUP or OFF	Auto SensUP
Shutter	Adjusts the electronic shutter speed (AES).	Sliding scale: – (60 at extreme left to 1/10000) +	1/60 sec. (NTSC) or 1/50 sec. (PAL)
Auto SensUP Max.	Sets the limit for sensitivity when the shutter speed is set to Auto SensUP.	15x, 7.5x, 4x, or 2x	15x
Night Mode (Day/Night models only)	Selects night mode (B/W) to enhance lighting in low light scenes.	ON, OFF, or AUTO	AUTO
Night Mode Color (Day/Night models only)	Determines if color processing remains in effect while in night mode.	ON or OFF	OFF
Night Mode Threshold (Day/Night models only)	Adjusts the level of light at which the camera automatically switches to night mode (B/W) operation.	Sliding scale: – (10 to 55) + (in increments of 5)	30
Pre-Comp (not applicable with IP AutoDome models)	Amplifies the video gain to compensate for long distance cable runs.	Sliding scale: – (1 to 10) +	1
Restore Defaults	Restores all default settings for this menu only.		

2.3 Lens Setup

The **Lens Setup Menu** provides access to lens settings that can be changed or customized. Menu items with an * are the default settings.

Lens Setup	
Exit...	
* Auto Focus:	SPOT
* Auto Iris:	CONSTANT
* Auto Iris Level:	8
* Focus Speed:	2
* Iris Speed:	5
* Max Zoom Speed:	FAST
* Digital Zoom:	ON
Restore Defaults	
* = Factory Setting Focus / Iris: Select	

Lens Setup Menu Choices:

Menu	Description	Sub-menu / Description	Default Setting
Exit	Saves and exits the menu.		
Auto Focus	Automatically focuses on the subject in the center of the screen.	CONSTANT: Auto Focus is always active, even while the camera is moving. MANUAL: Auto Focus is inactive; manual focus must be used. SPOT: The camera activates Auto Focus after the camera stops movement. Once focused, Auto Focus is inactive until the camera moves again.	SPOT
Auto Iris	Automatically adjusts to varying light conditions.	MANUAL: Iris must be adjusted manually. CONSTANT: Auto Iris is constantly active.	CONSTANT
Auto Iris Level	Reduces the camera's iris level for proper exposure.	Sliding scale: – (1 to 15) +	8
Focus Speed	Adjusts the manual focus speed.	Sliding scale: – (1 to 8) +	2
Iris Speed	Adjusts the manual iris speed.	Sliding scale: – (1 to 10) +	5
Max. Zoom Speed	Adjusts the manual zoom speed.	SLOW, MEDIUM, or FAST	FAST
Digital Zoom (not available with 200 Series models)	Enables digital zoom.	OFF or ON	ON
Restore Defaults	Restores all default settings for this menu.		

2.4 PTZ Setup Menu

The **PTZ Menu** provides access to pan/tilt/zoom settings that can be changed or customized. Menu items with an * are the default settings.

PTZ Setup	
Exit...	
* AutoPan:	30 deg/sec
* Tour 1 Period:	5 sec
* Tour 2 Period:	5 sec
* PTZ Fixed Speed:	4
* Inactivity:	OFF
* Inact. Period	2 min
* AutoPivot:	ON
* AutoDome Orientation	NORMAL
* Freeze Frame on Preposition	ON
Tilt Up Limit...	
Restore Defaults	
* = Factory Setting Focus / Iris: Select	

PTZ Menu Choices:

Menu	Description	Sub-menu / Description	Default Setting
Exit	Exits the menu.		
AutoPan	Adjusts speed of camera during AutoPan and AutoScan.	Sliding scale: – (1°/sec. to 60°/sec.) +	30°/sec.
Tour 1 Period	Changes dwell time between presets during the tour.	Sliding scale: – (3 sec. to 10 min.) +	5 sec.
Tour 2 Period (not available with 200 Series models)	Changes dwell time between presets during the tour.	Sliding scale: – (3 sec. to 10 min.) +	5 sec.
PTZ Fixed Speed	Sets pan and tilt speed when controlled by a fixed speed controller.	Sliding scale: – (1 to 15) +	4
Inactivity	Selects the mode that an AutoDome reverts to after the period of inactivity set in the inactivity period.	Scene 1: Returns to Preset 1. Prev Aux: Returns to previous activity, such as Aux commands 1, 2, 7, 8, 50, or 52. OFF: Remains on the current scene indefinitely.	OFF
Inactivity Period	Sets the time period of inactivity before the above action occurs.	Sliding scale: – (3 sec. to 10 min.) +	2 min.
AutoPivot	Automatically rotates the camera 180° when following a subject traveling directly beneath the camera.	OFF or ON	ON
AutoDome Orientation (not available with 18x color camera)	Automatically rotates the video 180°.	INVERTED or NORMAL	NORMAL

Menu	Description	Sub-menu / Description	Default Setting
Freeze Frame On Preposition (not available with 18x color camera)	Holds a preposition video frame while moving to another preposition.	OFF or ON	ON
Tilt Up Limit...	Sets the upper tilt limit of the camera.	Use joystick to move to a scene	
Restore Defaults	Restores the default setting for this menu only.		

2.5 Display Setup Menu

Provides access to display settings that can be changed or customized. Menu items with an * are the default settings.

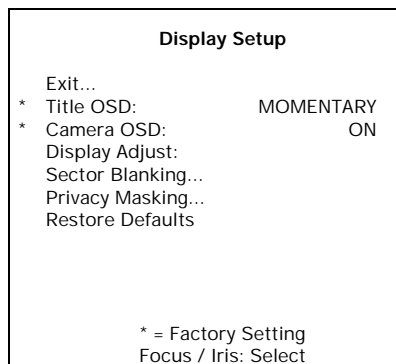

Display Setup Menu Choices:

Menu	Description	Sub-menu / Description	Default Setting
Exit	Saves and exits the menu.		
Title OSD	Controls how the OSD displays sector or shot titles.	OFF: Titles are hidden. ON: Titles are displayed continuously. MOMENTARY: Titles are displayed for a few seconds then disappear from the screen.	MOMENTARY
Camera OSD	Controls how the OSD displays camera response information, such as Digital Zoom, Iris open/close, and Focus near/far.	OFF or ON	ON
Display Adjust	Adjusts the text brightness and vertical position of the on-screen title.	Exit: Exits the menu. Up: Moves screen title up. Down: Moves screen title down. Brighter: Brightens the intensity of the on-screen text. Darker: Darkens the intensity of the on-screen text.	
Sector Blanking (not available with 200 Series models)	Allows video blanking of selected sectors. Available sectors are 1 through 16. Follow the on-screen instructions.	Exit: Exits the menu. Sector (1-16): Press Focus/Iris to blank or clear a sector.	
Privacy Masking (not available with 200 Series models)	Allows masking of sensitive areas. Up to 24 privacy masks are available, with a maximum limit of eight (8) to a scene.	Exit: Saves and exits menu. Mask: 1 to 24 masking areas. Follow the on-screen instructions to set a mask. See <i>Section 7.3: Privacy Masking</i> on page 37. Restore Defaults: Restores the default settings for this menu only.	
Restore Defaults	Restores the default setting for this menu only.		

2.6 Communication Setup Menu

The **Communication Setup Menu** provides access to baud rate and Bilinx control settings. Menu items with an * are the default settings.

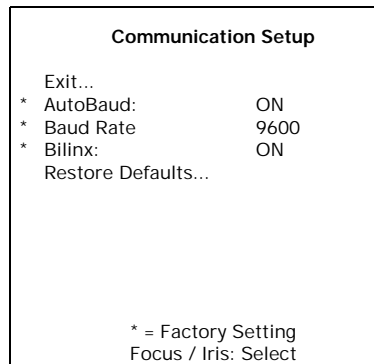

Communication Setup Menu Choices:

Menu	Description	Sub-menu / Description	Default Setting
Exit	Saves and exits the menu.		
AutoBaud	Turns AutoBaud detection on.	Toggles ON or OFF . ON automatically accepts baud rates from 2400 to 57600. (Note: If stepping from 2400 to 57600, you must first set the controller to 19200 for AutoBaud to detect the higher baud rate.)	ON
Baud Rate	Manually sets the baud rate when AutoBaud is set to OFF.	Choices are 2400, 4800, 9600, 19200, 38400, and 57600. Then follow the OSD to confirm the selection.	9600
Bilinx	Turns on Bilinx control communication, (Only available when not connected to a Bilinx data interface unit).	Toggles ON or OFF .	ON



NOTICE! Bilinx protocol is not available on IP cameras.

2.7 Alarm I/O Setup

The **Alarm Setup Menu** provides access to the **Alarm I/O Setup Menu** to establish the alarm inputs and outputs and to configure alarm rules.

<p>Alarm I/O Setup</p> <p>Exit... Inputs Setup... Outputs Setup... Rule Setup... Restore Defaults...</p> <p style="text-align: right;">Focus / Iris: Select</p>	<p>Inputs Setup</p> <p>Exit... 1. Alarm Input 1 N.C.S. 2. Alarm Input 2 N.O.S. 3. Alarm Input 3 N.O. 4. Alarm Input 4 N.C. 5. Alarm Input 5 N.O. 6. Alarm Input 6 N.C. 7. Alarm Input 7 N.O. 8. NONE 9. NONE 10. NONE 11. NONE 12. NONE</p> <p style="text-align: right;">Focus / Iris: Select Type Right / Left: Select Mode</p>	<table border="1"> <tr> <td style="text-align: center;">1-7</td> </tr> <tr> <td style="text-align: center;">Physical Inputs</td> </tr> <tr> <td style="text-align: center;">8-12</td> </tr> <tr> <td style="text-align: center;">Command Inputs</td> </tr> </table>	1-7	Physical Inputs	8-12	Command Inputs
1-7						
Physical Inputs						
8-12						
Command Inputs						

Alarm Setup Menu Choices:

Menu	Description	Sub-menu / Description	Default Setting
Exit	Saves and exits the menu.		
Inputs Setup	Defines physical inputs or events and commands that can be used in a rule. There are twelve (12) alarm inputs available.		
Inputs 1-7	Defines the type of physical input.	N.O.: Normally open dry contact. N.C.: Normally closed dry contact. N.C.S.: Normally closed supervised contact. N.O.S.: Normally open supervised contact.	N.O.
Inputs 8-12	Defines input commands that can be used in a rule. Command inputs can also be customized by using non-assigned keyboard command numbers.	NONE: No command defined. Aux On: Programs a standard or custom keyboard ON (1-99) command. Aux Off: Programs a standard or custom keyboard OFF (1-99) command. Shot: Programs a Preset shot or scene from 1-99. (200 Series 1-64). AutoTrack: Triggers an alarm when set to ON . (Available with 500i Series only). Motion Detection: Triggers an alarm when set to ON . (Available with 500i Series only).	NONE



NOTICE! Alarm inputs 1 and 2 provide tamper detection, if programmed as supervised, for breaks or shorts in an alarm circuit. See the *AutoDome Modular Camera System Installation Manual* for wiring instructions.

Outputs Setup Menu

Outputs Setup...

Exit...

1. Alarm Output 1	N.O.
2. Alarm Output 2	N.O.
3. Alarm Output 3	N.O.
4. Alarm Relay	N.O.
5. NONE	
6. Aux On	1
7. Aux Off	8
8. Shot	99
9. OSD	
10. Transmit	
11. NONE	
12. NONE	

Focus / Iris: Select Type
Right / Left: Select Mode

1-4
Physical Outputs
5-12
Command Outputs

Outputs Setup Menu

Menu	Description	Sub-menu / Description	Default Setting
Exit	Saves and exits the menu.		
Outputs Setup	Defines physical outputs and keyboard commands for use in a rule.		
Outputs 1-3	Defines a physical output.	N.O.: Normally open circuit N.C.: Normally closed circuit	N.O.
Alarm Relay	A fixed output available for use in a rule.		
Outputs 5-12	Defines a command output for use in a rule.	Aux On: A keyboard ON command. Aux Off: A keyboard OFF command. Shot: Recalls a preset shot. OSD: An on screen display. Transmit: Transmits a message back to the head end (available with RS-232 serial connections, Bilinx, and IP AutoDome models). AutoTrack: Activates AutoTrack. (Available with 500i Series only). NONE: No command defined.	NONE. Outputs 5 and 6 set to OSD and Shot 1

2.8 Rule Setup Menu

The **Rule Setup Menu** shows the status of the rules and lets you add new rules or modify an existing rule. The default setting is **Empty**.



NOTICE! You can program a total of 12 rules. You must define the inputs and outputs before you program a rule. See *Section 2.7: Alarm I/O Setup* on page 16 for instructions on configuring alarm inputs and outputs.

Rule Setup...	
Exit...	
1. Rule 1	Enabled
2. Rule 2	Disabled
3. Rule 3	Invalid
4. Rule 4	Empty
5. Rule 5	Empty
6. Rule 6	Empty
7. Rule 7	Empty
8. Rule 8	Empty
9. Rule 9	Empty
10. Rule 10	Empty
11. Rule 11	Empty
12. Rule 12	Empty
Focus / Iris: Select	

Rule 1	
Exit...	
Enabled	YES
Input:	
Alarm Input 1	NONE
NONE	NONE
NONE	NONE
Output:	
OSD	
Shot 2	
Alarm Relay	2 sec
NONE	
Right / Left: Select Period Time	
Focus / Iris: Select Type	

Rule Setup Menu Choices:

Menu	Description	Sub-menu / Description	Default Setting
Exit	Saves and exits the menu.		
Rule 1-12	Displays the status of a rule on the right side of the menu. There are four (4) possible rule statuses.	<p>Enabled: The rule inputs and outputs are properly defined and the rule is turned on.</p> <p>Disabled: The rule inputs and outputs are defined but the rule is turned off.</p> <p>Invalid: The rule has a missing or invalid input or output.</p> <p>Empty: The rule has no inputs or outputs defined.</p>	Empty

Selecting a **Rule** number provides access to its configuration menu. The **Rule # Menu** allows you to configure a rule from previously defined alarm inputs and outputs. Once an alarm is configured with valid inputs and outputs, it can be turned on or off (enabled or disabled) through its configuration menu.

Rule # Choices:

Menu	Description	Sub-menu / Description	Default Setting
Exit	Saves and exits the menu.		
Enabled	Turns the rule on or off after its inputs and outputs have been defined.	YES to enable or NO to disable	NO
Input	Toggles through a list of valid inputs set in the Alarm I/O Setup > Inputs Setup Menu that define the rule's inputs. A rule can have up to four (4) inputs.	Alarm Inputs 1 – 7 and any additional inputs which were set in the Inputs Setup Menu , including Aux On/Off (1-99) , Shot , and NONE .	NONE
Output	Toggles through a list of valid outputs set in the Alarm I/O Setup > Outputs Setup Menu that defines a rule's outputs.	Alarm Outputs 1 – 3 and any additional outputs set in the Outputs Setup Menu including: Alarm Relay , Aux On/Off (1-99) , Shot , OSD , Transmit , and NONE . Some outputs, such as Alarm Outputs 1-3 , Alarm Relay , and Aux On/Off can be set to be active for a specific duration of time as follows: Seconds: 1-5, 10, 15, or 30 Minutes: 1-5 or 10 Latched: The alarm stays active until acknowledged. Follows: The alarm follows the alarm rule.	NONE



NOTICE! You can include up to four (4) **Input** and **Output** events in a single rule. Each input and output, however, must be true for the alarm's rule to be valid and enabled.

2.9 Language Menu

The **Language Menu** provides access to a list of languages to display the on-screen menus.



Language Menu Choices:

Menu	Description	Default Setting
Exit	Saves and exits the menu.	
Choose a language	Select a language in which the system displays the on-screen menus.	

2.10 Advanced Feature Setup Menu (available with Series 500i only)

The **Advanced Menu** provides access to the **Advanced Features Setup** menus such as image stabilization and virtual masking.

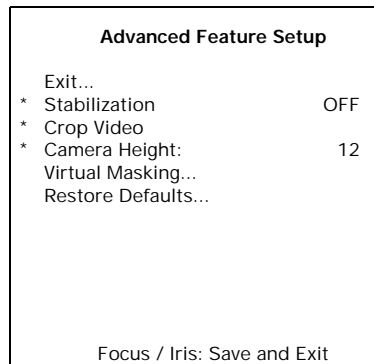

Advanced Feature Setup Menu Choices:

Menu	Description	Sub-menu / Description	Default Setting
Exit	Saves and exits the menu.		
Stabilization	Turns on video stabilization.		OFF
Crop Video	Turns on cropping to a stabilized video image.		
Camera Height	Defines the height of the camera for AutoTrack.	A range from 8 ft (2.4 m) to 100 ft (30.7m)	12 ft (3.6 m)
Virtual Masking	Enters the Virtual Mask menu. See <i>Section 7.4: Virtual Masking</i> on page 37.	Allows up to 24 virtual masks using five anchor points.	
Restore Defaults	Restores the default settings for this menu.		

2.11 Diagnostics Menu

The Diagnostics menu provides access to a list of diagnostic tools and events.

Diagnostics	
Exit...	
Alarm Status...	
BIST...	
Internal Temp:	Deg F / Deg C
High Temp Events:	Deg F / Deg C
Highest Temp	Deg F / Deg C
Low Temp Events:	Deg F / Deg C
Lowest Temp	Deg F / Deg C
Security Access:	0
CTFID Access:	0
Homing Events:	0
Homing Failed:	0
Restart Events:	0
Low Volt Events:	0
Power Up Events:	0
Video Loss Events:	0
Focus / Iris: Save and Exit	

Diagnostics Events:

Menu	Description	Sub-menu / Description
Exit	Saves and exits the menu.	
Alarm Status	Enters the Alarm Status menu and displays the real time status of alarm inputs and outputs.	Alarm Inputs 1 to 7, Alarm Outputs 1 to 3, and Alarm Relay
BIST	Enters the Perform Built-in Self Tests menu. If confirmed, the BIST tests start and the results displayed.	YES to start the BIST test. NO to exit the Perform Built in Self Tests menu.
Internal Temp.	Displays the current dome temperature.	
High Temp Events	Displays the number of times the high temperature threshold is exceeded.	
Highest Temp	Displays the highest temperature reached.	
Low Temp Events	Displays the number of times the low temperature threshold is exceeded.	
Lowest Temp	Displays the lowest temperature reached.	
Security Access	Displays the number of times the locked-command menu is unlocked.	
CTFID Access	Displays the number of times the Configuration Tool is accessed.	
Homing Events	Displays the number of times the AutoDome was rebooted.	
Homing Failed	Displays the number of times the AutoDome failed to home properly.	
Restart Events	Displays the number of restart events.	
Low Volt Events	Displays the number of times the AutoDome dropped below the acceptable voltage limit.	
Power Up Events	Displays the number of power up events.	
Video Loss Events	Displays the number of time that video was lost.	

3 Common AutoDome User Commands (unlocked)

This chapter details the commonly used BOSCH keyboard setup commands. See *Section 6: Keyboard Commands by Number* on page 33 for a complete list of commands.

3.1 Setting AutoPan Mode

AutoPan mode pans a PTZ camera 360° or pans between user defined limits (when programmed). The PTZ camera continues to pan until stopped by moving the joystick.

To pan 360°:

1. Press **ON-1-ENTER**.
2. Move the joystick to stop the pan.

To set left and right pan limits:

1. Move the camera to the starting position and press **SET-101-ENTER** to set the left limit.
2. Move the camera to the end position and press **SET-102-ENTER** to set right limit.

To start Auto-pan between limits:

1. Press **ON-2-ENTER**.
2. Move the joystick to stop the pan.

3.2 Setting Preset Shots

Preset shots are saved camera positions. Shots are saved as scenes, therefore, the terms **SHOT** and **SCENE** are used interchangeably.

To set a Shot:

1. Move the camera to the position you want to save.
2. Press **SHOT-#-ENTER** where # can be a number from 1 to 99 that identifies the camera position of the scene. (shots 1-64 for a 200 Series AutoDome.)

To view a Shot:

- ▶ Press **SHOT-#-ENTER** where # is the number of the scene position you want to view.

To store or clear a Shot:

1. Press **SET-100-ENTER** to access the **Store/Clear Scene Menu**.
2. Follow the on-screen instructions.

3.3 Configuring Preposition Tours

A **Preposition Tour** automatically moves the camera through a series of preset or saved shots. There are two (2) types of tours: a standard serial tour and a customized tour.

Tour 1 is a standard tour that moves the camera through a series of shots in the sequence they were set. **Tour 2** is a custom tour that allows you to change the sequence of shots in the tour by inserting and deleting scenes.

To start standard Tour 1:

1. Set a series of preset shots in the order that you want the AutoDome to cycle through.
2. Press **ON-8-ENTER** to start the tour. The tour then cycles through the series of shots until it is stopped.

To stop a Tour:

- ▶ Press **OFF-8-ENTER** or move the joystick to stop either type of tour.

To add or remove scenes to standard Tour 1:

1. Press **SHOT-900-ENTER** to access the **Add/Remove Scenes Menu**.
2. Use the **Focus/Iris** buttons to add or remove the selected scene from the tour.

To start custom Tour 2:

- ▶ Press **ON-7-ENTER** to start a tour. The tour cycles through the series of shots in the order they were defined until it is stopped.

To edit a custom Tour 2:

1. Press **SET-900-ENTER** to access the **Add/Remove Menu**.
2. Press the **Focus/Iris** buttons to add or remove the selected scene.

To change the dwell period of a tour:

1. Press **ON-15-ENTER** to access the **Tour Period Menu**.
2. Select the tour (**Tour 1** or **Tour 2**) and follow the on-screen instructions.

3.4 Programming the Inactivity Operation

You can program the AutoDome to automatically change its operating mode after a period of inactivity.

To access the Inactivity mode (locked command):

1. Press **OFF-90-ENTER** to turn off the command lock.
2. Press **ON-9-ENTER** to access the **Inactivity Mode Menu**.
3. Select one of the following choices:
 - **Return to Scene 1:** Returns the camera position back to the first scene saved in memory.
 - **Recall Previous Aux:** Returns the camera to the previous operating mode, such as a **Preposition Tour**.

3.5 Recording Tours

The AutoDome can make up to two (2) recorded tours. A **Recorded Tour** saves all manual camera movements made during the recording, including its rate of pan, tilt and zoom speeds and other lens setting changes.

To record standard Tour A:

1. Press **ON-100-ENTER** to start recording a tour.
2. Press **OFF-100-ENTER** to stop recording.

To playback standard Tour A:

1. Press **ON-50-ENTER** to begin continuous playback.
2. Press **OFF-50-ENTER** or move the joystick to stop playback

To record custom Tour B:

1. Press **ON-101-ENTER** to start recording the tour.
2. Press **OFF-101-ENTER** to stop the tour.

To playback custom Tour B:

1. Press **ON-52-ENTER** to begin continuous playback.
2. Press **OFF-52-ENTER** or move the joystick to stop playback.

4 Pelco® Protocol Mode

The Pelco Mode features Auto Baud Detection that automatically detects and adjusts the AutoDome protocol and baud rate to match that of the controller. The AutoDome responds to Pelco-D or Pelco-P protocol commands.



NOTICE! The AutoDome supports only the RS-485 protocol. It does not transmit responses back to the controller.

4.1 Hardware Configuration

The AutoDome is configured from the factory for RS-485 operation in **Pelco Protocol Mode**.

1. Connect the controller's TX terminals to the AutoDome's TxD terminals. See the *AutoDome Modular Camera System Installation Manual* for complete wiring instructions.
2. Pan or tilt the keyboard joystick to confirm that control has been established to the AutoDome (approximately five (5) seconds).



NOTICE! If control is not established, ensure that the RS-232/RS-485 selector switch is positioned to RS-485 (outward toward the LED lights). This switch is located on the bottom of the AutoDome CPU board, under the camera head and next to the LED lights. See *Figure 4.1*.

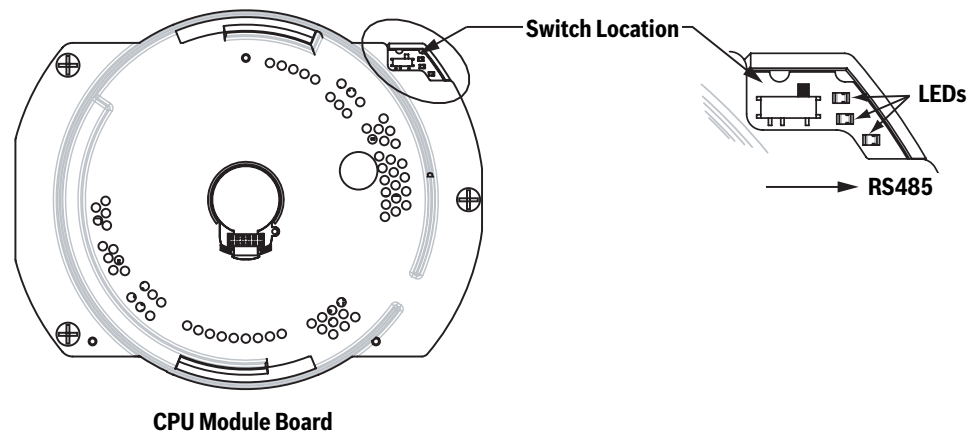

Fig. 4.1 RS-232/RS-485 Selection Switch

4.2 Address Guidelines

- An AutoDome with an address set to 0 responds to commands set to any address.
- **Pelco-P** protocol must use addresses 1 to 32.
- **Pelco-D** protocol must use addresses 1 to 254.



NOTICE! A previously configured AutoDome with an address above 32 (Pelco-P upper limit) or 254 (Pelco-D upper limit) can be used without readdressing the unit. However, no two (2) addresses can be the same. For example:
Pelco-P addresses above 32 are repeated in multiples of 32 (1, 33, 65, 97 are the same).
Pelco-D addresses above 254 are repeated in multiples of 254 (1, 255, 509, 763 are the same).

4.3 Pelco Keyboard Commands

Pelco control commands are composed of a sequence of two (2) keyboard inputs with the following convention: 1) a **Command Number** and 2) a **Function** key input.
The AutoDome uses the **PRESET** command key to save and recall presets (pre-positions) 1 through 99.



NOTICE! To save a preset, enter the desired number and hold the **PRESET** key for approximately two (2) seconds. To recall a preset, enter the desired preset number (or command) and momentarily press and release the **PRESET** key.

4.3.1 Special Preset Commands

Some **Pelco** mode preset commands have a special meaning and override the normal Pelco preset function as follows:

Preset Command	Description
33-PRESET	Pans the AutoDome 180° (Flip).
34-PRESET	Goes to Zero Pan (original home position).
92-PRESET	Sets the Left pan limit for an AutoScan with Limit Stops enabled.
93-PRESET	Sets the Right pan limit for an AutoScan with Limit Stops enabled.
94-PRESET	Initiates a Preset Tour .
95-PRESET	Enables or disables Limit Stops in the Setup Menu for AutoScan. Invokes the Pelco main Setup Menu when pressed for 2 seconds.
96-PRESET	Stops a scan.
97-PRESET	Initiates FastAddress (Pelco Random Scan).
98-PRESET	Toggles the Synch. Mode between Line Lock and Internal (Pelco Frame Scan). This command is available only for two (2) minutes after the power is applied and then reverts to normal preset functionality.
99-PRESET	Starts an AutoScan



NOTICE! Some Pelco controllers do not support all the preset command numbers. Consult the specific Pelco controller's documentation for supported preset commands.

5 Pelco On-Screen Menus

You can program the AutoDome through the Pelco on-screen display (OSD) menus. To access the Pelco menus, you must configure the AutoDome for **Pelco Mode** and invoke the Pelco main **Setup Menu**.

5.1 Setup Menu

The Pelco main **Setup Menu** provides access to the programmable AutoDome settings. Some menu items are locked and require a system password to use. Menu items marked with an * are the default settings.

To open the Pelco main Setup Menu (locked commands):

1. Press **95-PRESET** (press the **PRESET** button for approximately 2 seconds to open).
2. Use the joystick to highlight a menu item.
3. Press either the **Focus** or the **Iris** key to open a menu item.
4. Follow the on-screen instructions at the bottom of the screen.

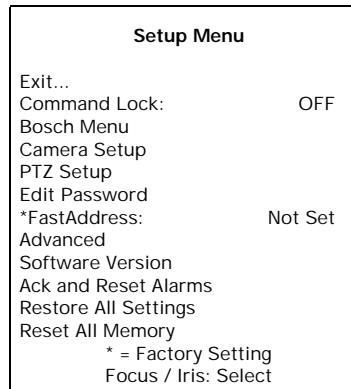

NOTICE! Use Zoom to select the **Exit** item from anywhere in a menu.

Menu	Description
Exit	Exits the menu.
Command Lock (locked)	Allows or prohibits accessing locked commands. (If password is set, you are prompted to enter the password.)
Bosch Menu (locked)	Accesses the full AutoDome configuration menu and all AutoDome settings.
Camera Setup	Accesses the White Balance and Night Mode camera settings.
PTZ Setup	Accesses the tours, tour periods, scan speed, edit presets, limit stops, recording, and AutoPivot settings.
Edit Password (locked)	Changes the password.
FastAddress (locked)	Sets or changes a camera address.
Software Version	Displays the current software versions.
Ack and Reset Alarms	Acknowledges and resets active alarms.
Restore All Settings (locked)	Restores all settings to their original default setting.
Reset All Memory (locked)	Clears all settings, including scene shots, tours, and recordings stored in the AutoDome memory.



NOTICE! After a period of 4.5 minutes of inactivity, the OSD menu times-out and exits without warning. Some unsaved settings can be lost!

5.1.1

Command Lock (locked)

The Pelco **Command Lock Menu** allows or prohibits the use of locked commands. The default setting is **ON**.



NOTICE! If the Command Lock is set to **ON** and you press **Focus** or **Iris** on a locked command, the AutoDome displays the on-screen message: "*Command is Locked.*"

5.1.2

Bosch Menu (locked)

The **Bosch Menu** allows full access to the AutoDome main **Setup Menu** and all AutoDome configuration settings.

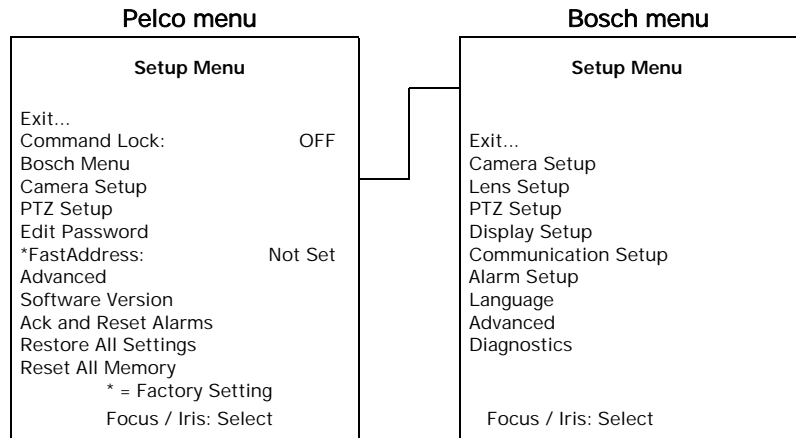

Refer to *Chapter 2: On-Screen Display Menu Navigation* for a complete description of Bosch menus and configuration settings.

Camera Setup (unlocked)

The Pelco **Camera Setup Menu** provides access to camera settings.

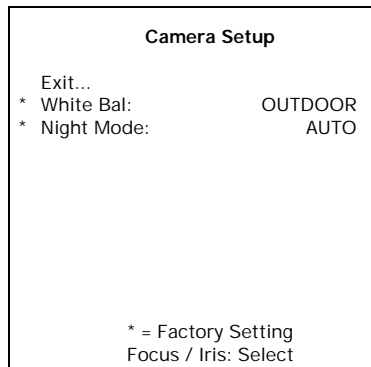

Camera Setup Menu Choices:

Menu	Description	Sub-menu / Description	Default Setting
Exit	Exits the menu.		
White Balance	Sets a default value in case the Pelco controller disables the white balance.	OUTDOOR : Sets a default setting if the controller disables white balance. INDOOR : Sets a default setting if the controller disables white balance.	OUTDOOR
Night Mode	Switches from color to monochrome.	ON : Sets Night Mode on. OFF : Sets Night Mode off. AUTO : Sets Night Mode to Auto set.	ON (Day/Night models only)

5.1.3 PTZ Setup (unlocked)

The Pelco **PTZ Setup Menu** provides access to the PTZ settings such as tours, scan speed, presets, limit stops, recording, and AutoPivot.

PTZ Setup	
Exit...	
* Edit Tour 1...	
* Edit Tour 2...	
* Tour 1 Period:	5 sec
* Tour 2 Period:	5 sec
* Scan Speed	30 deg/sec
Edit Presets...	
* Limit Stops:	OFF
* Recording:	"A"
* Autopivot:	ON
* = Factory Setting	
Focus / Iris: Select	

PTZ Setup Menu Choices:

Menu	Description	Sub-menu / Description	Default Setting
Exit	Exits the menu.		
Edit Tour 1	Accesses the Add / Remove Scenes On Standard Tour 1 Menu .	Exit: Exits the menu. Scene (1 - 5): Adds or removes scenes from the Standard Tour .	
Edit Tour 2	Accesses the Edit Custom Tour Menu .	Exit: Exits the menu. Scene (1 - 5): Adds or removes scenes from the Custom Tour .	
Tour 1 Period	Changes the length of waiting time between presets.	Sliding scale: – (3 sec. to 10 min.) +	5 sec.
Tour 2 Period	Changes the length of waiting time between presets.	Sliding scale: – (3 sec. to 10 min.) +	5 sec.
Scan Speed	Changes the Autopan and AutoScan speeds.	Sliding scale: – (1°/sec to 60°/sec) +	30°/sec.
Edit Presets	Modifies preset scenes.	1-99 scenes	
Limit Stops	Toggles the Limit Stops for AutoScan.	ON or OFF	OFF
Recordings	Selects record Pattern 1 or 2, if normal pattern command does not respond.	"A" or "B" .	"A"
AutoPivot	Follows a subject while beneath the camera, without inverting the picture.	ON or OFF	ON

5.1.4

Other Menus

Menu	Description	Default Setting
Edit Password (locked)	Sets or displays the password. See <i>Section 1.4: Setting Passwords</i> on page 5.	
FastAddress (locked)	Sets or changes the AutoDome address.	Not Set
Software Version (unlocked)	Displays the camera software version.	
Ack and Reset Alarms (unlocked) (not available with 200 series model)	Acknowledges and resets alarms. If there is no active alarm input, the OSD displays the following message: " <i>No Active Alarms.</i> "	
Restore All Settings (locked)	Restores all settings to their original factory default settings.	
Reset All Memory (locked)	Restores all settings to their original factory default settings and clears all user programmed settings such as preset scenes and recordings.	

6 Keyboard Commands by Number

Locked	Function Key	Comm No.	Command	Description	Series 200	Series 300	Series 500i
	On/Off	1	Scan 360°	Autopan without limits	✓	✓	✓
	On/Off	2	Autopan	Autopan between limits	✓	✓	✓
✓	On/Off	3	Iris Control	Enters menu (auto, manual)	✓	✓	✓
✓	On/Off	4	Focus Control	Enters menu (spot, auto, manual)	✓	✓	✓
	On/Off	7	Play Custom Pre-position Tour	Activate/Deactivate		✓	✓
	On/Off	8	Play Pre-position Tour	Activate/Deactivate	✓	✓	✓
✓	On/Off	9	Inactivity Mode	Enters menu (Off, Return to Scene 1, Recall Previous PTZ Command)	✓	✓	✓
✓	On/Off	11	Auto Iris Level adjust	Enters Iris Level Adjustment menu	✓	✓	✓
	On/Off	14	Set Autopan and Scan Speed	On–increase Off–decrease or adjust slide bar	✓	✓	✓
	On/Off	15	Set Pre-position Tour Period (dwell)	On–increase dwell Off–decrease dwell	✓	✓	✓
✓	On/Off	18	AutoPivot Enable	Enables/disables AutoPivot	✓	✓	✓
	On/Off	20	Backlight Comp	Backlight Compensation	✓	✓	✓
✓	On/Off	23	Electronic Shutter	Enters Shutter Speed menu	✓	✓	✓
	On/Off	24	Stabilization	Electronic Stabilization			✓
✓	On/Off	35	White Balance Mode	Enters White Balance menu	✓	✓	✓
✓	On	40	Restore Camera Settings	Restores all setting to their original defaults	✓	✓	✓
✓	On/Off	41	Line Lock Phase Adjust	On–increase Line Lock delay Off–decrease Line Lock delay	✓	✓	✓
✓	On/Off	42	Sync Mode	On–Line Lock Off–Internal	✓	✓	✓
✓	On/Off	43	Auto Gain Control	AGC–On, Auto, Off	✓	✓	✓
✓	On/Off	44	Sharpness	Enters Sharpness menu	✓	✓	✓
✓	On	46	Advanced menu	Enters Main Setup menu	✓	✓	✓
	On	47	View Factory Settings	View all menu default settings	✓	✓	✓
	On/Off	50	Playback A, continuous	Activate/Deactivate		✓	✓
	On/Off	51	Playback A, single	Activate/Deactivate		✓	✓
	On/Off	52	Playback B, continuous	Activate/Deactivate		✓	✓
	On/Off	53	Playback B, single	Activate/Deactivate		✓	✓
	On/Off	56	Night Mode menu	On, Off, Auto (Day/Night only)	✓	✓	✓
	On/Off	57	Night Mode setting	On, Off, Auto (Day/Night only)	✓	✓	✓
✓	On/Off	58	Day/Night Threshold	On–menu (Day/Night only)	✓	✓	✓
✓	On/Off	60	On Screen Display	On–enable Off–disable	✓	✓	✓
✓	On	61	Display Adjust	Adjust On-screen Display	✓	✓	✓
	On	62	Pre-position Title menu	Enters Pre-position Title menu	✓	✓	✓
✓	On	63	Zone Title menu	Enters Zone Title menu	✓	✓	✓
	On	64	Alarm Status	Enters Alarm Status menu		✓	✓
	Off	65	Alarm Acknowledge	Acknowledge alarm or deactivate physical outputs		✓	✓
	On	66	Display software version	Displays software version number	✓	✓	✓

Locked	Function Key	Comm No.	Command	Description	Series 200	Series 300	Series 500i
	On	72	Re-initialize camera	Performs camera/lens re-initialization functions	✓	✓	✓
	On/Off	78	AutoTrack	Turns AutoTrack on or off			✓
✓	On	79	Camera Height	Enters the Camera Height menu			✓
✓	On/Off	80	Digital Zoom Lock	Turns digital zoom on and off		✓	✓
	On/Off	81	Physical output 1	On—activates output Off—deactivates output		✓	✓
	On/Off	82	Physical Output 2	On—activates output Off—deactivates output		✓	✓
	On/Off	83	Physical Output 3	On—activates output Off—deactivates output		✓	✓
	On/Off	84	Physical Output 4	On—activates output Off—deactivates output		✓	✓
✓	On/Off	86	Sector Blanking	Enters Sector Blanking menu		✓	✓
✓	On/Off	87	Privacy Masking	Enters Privacy Masking menu		✓	✓
	On/Off	90	Command Lock/Unlock	On—lock on Off—lock off	✓	✓	✓
✓	On/Off	91	Lens Polarity menu	On—reverse Off—normal	✓	✓	✓
✓	On/Off	92	Lens Polarity menu	On—reverse Off—normal	✓	✓	✓
✓	On/Off	93	Lens Polarity menu	On—reverse Off—normal	✓	✓	✓
	On/Off	100	Record A	Activate/Deactivate		✓	✓
	On/Off	101	Record B	Activate/Deactivate		✓	✓
	On	997	FastAddress, display	Display current address	✓	✓	✓
	On	998	FastAddress, all units	Display and program current address	✓	✓	✓
	On	999	FastAddress, unaddressed domes	Display and program unaddressed AutoDomes	✓	✓	✓
	Set	"1-99"	Pre-position programming	Set ##—programs a preset view	"1-64"	✓	✓
	Shot	"1-99"	Pre-position recall	Shot ##—recall programmed preset	"1-64"	✓	✓
	Set	100	Pre-position menu	Enters the Pre-position menu	✓	✓	✓
	Set/Shot	101	Autopan left limit	Set—programs left limit Shot—shows limit	✓	✓	✓
	Set/Shot	102	Autopan right limit	Set—programs right limit Shot—shows limit	✓	✓	✓
	Set	110	Factory P/T home position	Set—recalibrate home position	✓	✓	✓
✓	Set	802	Edit Password	Enters the Edit Password menu		✓	✓
✓	Set	899	Reset ALL	Restores all settings to original defaults and clears all user-programmed settings	✓	✓	✓
	Set	900	Edit Tour 1 (Standard)	Enters the Standard Tour Scene menu		✓	✓
	Shot	900	Edit Tour 2 (Custom)	Enters the Custom Tour Scene menu	✓	✓	✓
	Set/Shot	901-999	Adds/Removes a preposition shot from Tour 1	Set ###—adds preset Shot ###—removes preset	901-964	✓	✓

7 Advanced Features

This chapter details the advanced features of the AutoDome Modular Camera System.

7.1 Alarm Rules

The 300 and 500i Series AutoDome feature a powerful alarm rule engine. In its simplest form, an alarm rule can be defined to specify which input(s) activate which output(s). In its more complex form, a rule can be programmed to take any combination of input(s) and keyboard command(s) to perform a dome function. There are numerous combinations of alarm inputs and outputs that can be programmed into 12 alarm rules.

Following are two examples for setting up alarm rules. The first example is a basic alarm rule, the second example is a more complex or advanced rule.

Example 1: Basic Alarm Rule

Scenario: We want a door alarm contact to:

1. Flash an **OSD** message (*****ALARM 1*****) on the display when the alarm is triggered.
2. Move the AutoDome camera to a saved position. (For this example **Shot 7**.)
3. Transmit a Bilinx signal over the coax cable to the headend system, such as an Allegiant, to trigger an alarm response.

The sequence to program the above alarm rule example is as follows:

1. Define the **Alarm Input(s)**
 - a. Wire the door contact to **Input 1** in the AutoDome. This circuit is normally open.



NOTICE! For instruction on wiring alarm and relay connections, see the *AutoDome Modular Camera System Installation Manual*.

- b. From the **Inputs Setup** menu, ensure that **Alarm Input 1** is set to **N.O.** (This is the default setting for **Input 1**.)
 2. Define the **Alarm Outputs** from the **Outputs Setup** menu:
 - a. Ensure **Output 5** is set to **OSD**. (This is the default setting for **Output 5**.)
 - b. Set **Output 6** to **Shot 7**.
 - c. Set **Output 7** to **Transmit**. (a Bilinx signal to the head end)
 3. Set up the **Alarm Rule**. (For this example use **Rule 1**.)
 Select the **Inputs** from the **Rule Setup** menu:
 - a. Select **Rule 1**.
 - b. Set the first input to **Alarm Input 1**.
 Select the outputs:
 - c. Set the first output to **OSD**.
 - d. Set the second output to **Shot 7**.
 - e. Set the third output to **Transmit**.
 Enable the rule:
 - f. Highlight **Enabled** and select **YES**.

Example 2: Advanced Alarm Rule

Scenario: A 500i Series AutoDome located at an airport is set to **AutoPan Between Limits** from the parking garage to the airport terminal. The gate entering the airport has an alarm contact connected to the AutoDome, and the perimeter fence in the area of the gate has an infrared (IR) motion detection sensor connected to the AutoDome.

When both the gate contact and motion detector alarms are activated at the same time, we want the alarm rule to:

1. Flash an **OSD** message (*****ALARM 2*****) on the monitor.
2. Stop the AutoPan and move the camera to a saved position (**Shot 5**) viewing the fence.
3. Turn on **AutoTrack**.
4. Transmit a Bilinx signal to the head end system to trigger an alarm response.

The sequence to program this alarm rule example is as follows:

1. Wire and set the alarm **Input(s)**.
 - a. Wire the motion detector to **Input 1**. (This circuit is normally open.)
 - b. Wire the gate alarm contact to **Input 5**. (This circuit is normally closed.)



NOTICE! For instruction on wiring alarm and relay connections, see the *AutoDome Modular Camera System Installation Manual*.

From the **Inputs Setup** menu:

- c. Ensure **Input 1** (the motion detector) is set to **N.O.** (This is the default setting for **Input 1**.)
- d. Ensure **Input 5** (the gate contact) is set to **N.C.**
2. Set the alarm **Outputs** from the **Outputs Setup** menu:
 - a. Set **Output 5** to **OSD**.
 - b. Set **Output 6** to **Transmit**.
 - c. Set **Output 7** to **Shot 5**.
 - d. Set **Output 8** to **AutoTrack**.
3. Set up the **Alarm Rule** (For this example use **Rule 2**.)

Select the alarm **Inputs**:

- a. From the **Rule Setup** menu select **Rule 2**.
- b. Set the first input to **Alarm Input 1**. (The motion detector.)
- c. Set the second input to **Alarm Input 5**. (The gate alarm contact.)

Select the alarm **Outputs**:

- d. Set the first output to **OSD**.
- e. Set the second output to **Shot 5** viewing the fence.
- f. Set the third output to **AutoTrack** and select Latched.
- g. Set the fourth output to **Transmit** (a Bilinx signal to the headend).

Enable the alarm **Rule**:

- h. Highlight **Enabled** and select **YES**.

7.2 AutoTrack

The 500i Series AutoDome features enhanced **AutoTrack** software with more versatility and smoother object tracking. **AutoTrack** is now able to continuously follow an object even if it passes behind a **Privacy Mask**. When used with **Virtual Mask**, it is able to ignore predefined areas of background motion.

- To turn on **AutoTrack**, enter the keyboard command **ON-78-ENTER**.
- In **Pelco Mode**, open the **Main** menu, select the **Advanced** menu, and then select **AutoTrack On**.



NOTICE! For proper operation AutoTrack requires that the camera height be set in the software. Open the Bosch Main menu, select the Advanced menu and select Camera Height to enter the camera height.

7.3 Privacy Masking

Available with 300 and 500i Series AutoDomes, **Privacy Masking** is used to block out a specific area of a scene from being viewed. Mask choices have been expanded to include black, white, or blurred, and can be configured with three, four, or five corners to cover more complex shapes.



NOTICE! **Privacy Masking** does not hinder **AutoTrack** from tracking an object.

- **Privacy Masking** can be accessed through the **Main** menu, by selecting **Display Setup**, and then **Privacy Mask**, or entering the keyboard command **ON-87-ENTER**. To setup a privacy mask, follow the on-screen menu instructions.
- In **Pelco Mode**, **Privacy Masking** can be accessed through the **Pelco Main** menu, by selecting the **Bosch Menu**, then selecting the **Display Setup** menu, and finally selecting **Privacy Masking**. To setup a privacy mask, follow the on-screen menu instructions

7.4 Virtual Masking

Only available with the 500i Series AutoDome, **Virtual Masking** is a unique Bosch technology that allows you to create an "invisible" area that ignores unwanted background motion. These invisible masks are similar to privacy zones, except that the AutoDome **AutoTrack** and **Motion Detection** algorithms can see them.

- **Virtual Masking** can be accessed by opening the **Main** menu, selecting the **Advanced** menu, then selecting **Virtual Masking**. To setup a **Virtual Mask** follow the on-screen menu instructions.
- In **Pelco Mode**, open the **Main** menu, select the **Advanced** menu, then select **Virtual Masking**. To setup a **Virtual Mask** follow the on-screen menu instructions.

7.5 Motion Detection with Region of Interest

With the 500i Series AutoDome, the motion detection software can be configured to create a **Region of Interest** within multiple preset positions or scenes. It can take advantage of **Virtual Masking** to ignore motion in predefined areas. **Motion Detection** can also be used as an **Alarm Rule** input.

Preset positions 90 through 99 are reserved for programming motion detection scenes.



NOTICE! **Motion Detection** always takes precedence over **AutoTrack** object tracking.

To set up a scene with Motion Detection:

1. Choose an unused Preset position from 90 to 99. For this example use Preset scene 95.
2. Enter the keyboard command **SET-95-ENTER**.
3. Select **YES** at the **Apply Motion Detection?** prompt. (If **NO** is selected, the Preset scene does not activate **Motion Detection**.)
4. Select **YES** at the **Apply Region of Interest?** prompt. (If **NO** is selected, the entire scene is used for **Motion Detection**.)
5. Follow the on-screen menu instructions to construct the shape of the screen area you want to detect motion within.



NOTICE! Up to five (5) anchor points can be used to form the area which you want to detect motion within.

NOTICE! Motion Detection is not activated until the Preset scene is recalled. The **Motion Detection** icon "M" appears in the upper left-hand corner of the display.

7.6

Image Stabilization and Crop Video

Image Stabilization becomes increasingly important as zoom ranges are extended. The advanced image stabilization algorithms of the 500i Series eliminate camera shake for exceptional image clarity. Bosch achieves this clarity without reducing camera sensitivity or picture quality.

The **Crop Video** feature is used in combination with image stabilization to enhance the peripheral edge aesthetics of a stabilized image.

- The **Image Stabilization** and **Crop Video** menu items are accessed by opening the **Main** menu, selecting the **Advanced** menu, and then selecting the item to turn it on.
- In **Pelco Mode**, the **Image Stabilization** and **Crop Video** menu items are accessed by opening the **Main** menu, selecting the **Advanced** menu, and then selecting the item to turn on.

7.7

Pre-position Tour

The 300 and 500i Series AutoDomes feature two preset tours. Each scene is saved for playback later.

Tour 1 is a standard tour that only recalls the scenes in the exact sequence they were shot. Scenes can be added or deleted on the tour, but the sequence can not be changed. To enter the **Add/Remove Scenes on Tour 1** enter the keyboard command **SHOT-900-ENTER** and follow the on-screen instructions.

Tour 2 is a customizable tour that allows you to rearrange the sequence of scenes on the tour by inserting and deleting scenes. To enter the **Edit Tour 2** menu, enter the keyboard command **SET-900-ENTER** and follow the on-screen instructions.

8 Configuring and Using the IP AutoDome

The VG4-200, VG4-300, and VG4-500i Series AutoDomes can be ordered with an optional IP module that allows the AutoDome to transmit PTZ control commands and images over a TCP/IP network. It also allows users to configure the AutoDome camera display settings, camera operating settings, and to configure the network parameters.

The IP AutoDome incorporates a network video server in the IP module. The primary function of the server is to encode video and control data for transmission over a TCP/IP network. With its MPEG-4 encoding, it is ideally suited for IP communication and for remote access to digital video recorders and multiplexers. The use of existing networks means that integration with CCTV systems or local networks can be achieved quickly and easily. Video images from a single camera can be simultaneously received on several receivers.

8.1 Overview of Features

The IP module adds the following functionality to an AutoDome system:

Function	Description
Video encoding	The camera uses the MPEG-4 compression standard and ensures that the data rate remains low even with high image quality and can also be adapted to local conditions within wide limits.
Dual Streaming	Encodes dual data streams simultaneously according to two individually customized profiles. This feature creates two (2) data streams per camera that can serve different purposes. For example, one (1) data stream for local recording and one (1) data stream optimized for transmission over the Local Area Network (LAN).
Multicast	Enables simultaneous, real-time transmission to multiple receivers. The network must implement the UDP and IGMP V2 protocols as a prerequisite for Multicasting.
Configuration	You can configure all camera settings from a Web browser on the local network (Intranet) or on the Internet. You can also update the firmware, load device configurations, store configuration settings, and copy these settings from one camera to another.
Snapshots	Allows you to take and store individual video frames as JPEG images from the Web browser interface.
Backup	You can save video images as a file on a computer's hard drive from the Web browser interface.
Audio	Allows you to set the gain level for the audio signal from the Line In 1, Microphone, and the Line Out ports.
Record	Allows you to configure the recording options for the IP module. You can record video from the Livepage to a hard drive or you can opt to store up to 8 MB of video on the IP module.

8.2 System Requirements

The IP AutoDome requires specific software or hardware to allow a user to view live images and to configure camera settings over a TCP/IP network. These requirements are:

- A computer with the Microsoft Windows 2000 or XP operating system, network access, and the Microsoft Internet Explorer Web browser version 6.0 or later, or
- A computer with Microsoft Windows 2000 or XP operating system, network access, and reception software such as the Bosch VIDOS software or the Bosch Dibos 8.0, or
- An MPEG-4 compatible hardware decoder from Bosch Security Systems (such as the VIP XD) as a receiver and a connected video monitor.

If you choose to use a computer running Microsoft Internet Explorer or any of the Bosch software, the computer must conform to the following minimum requirements:

- Processor: 1.8 GHz Pentium IV
- RAM: 256 MB
- Video system: 128 MB video memory, 1024x768 display with a minimum of 16-bit color
- Network interface: 100-BaseT
- DirectX 9.0c
- Microsoft Internet Explorer, version 6.0 or higher
- Bosch MPEG ActiveX utility
- Java Virtual Machine (supplied)



NOTICE! Ensure the graphics card is set to 16-bit or 32-bit color. If you need further assistance, contact your PC system administrator.

8.3 Connecting the IP AutoDome to the PC

1. Install the IP AutoDome according to the instructions in the *AutoDome Modular Camera System Installation Manual*.
2. Connect an Ethernet cable from the IP AutoDome RJ45 connector to a dedicated network switch to bypass the Local Area Network (LAN).
3. Connect the dedicated network switch to the RJ45 connector on the PC . (See option A below.)



NOTICE! The IP AutoDome can also be connected directly to a PC using an Ethernet crossover cable with RJ45 connectors. (See option B below.)

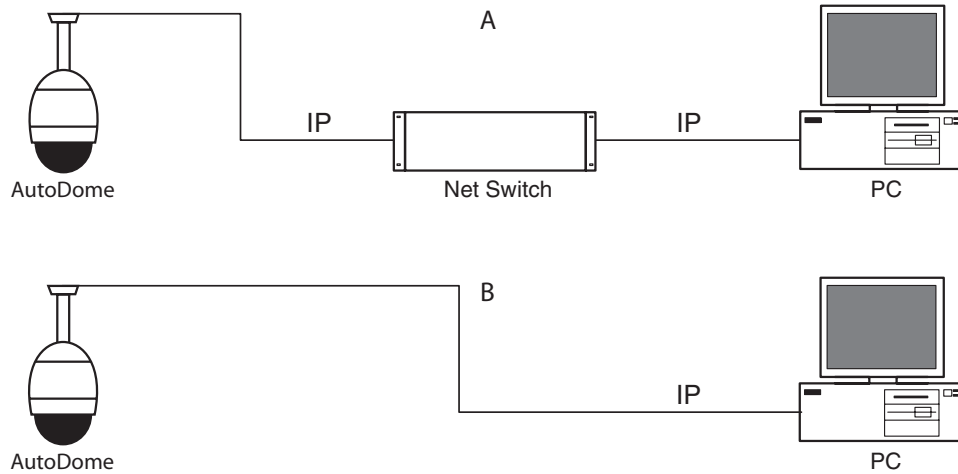

Fig. 8.1 AutoDome IP System Configuration

8.4

Configuring the IP Camera

To operate the camera in your network you must assign it a valid network IP address. The default IP address is 192.168.0.1, but you may have to change this address if it conflicts with another device on your network.

To properly configure the camera for your network, you need the following information:

- Unit IP address: An identifier for the camera on a TCP/IP network. For example, 140.10.2.110 is a valid syntax for an IP address.
- Subnet mask: A mask used to determine what subnet an IP address belongs to.
- Gateway IP address: A node on a network that serves as an entrance to another network.
- Port: An endpoint to a logical connection in TCP/IP and UDP networks. The port number identifies the use of the port for use through a firewall connection.



NOTICE! Ensure that the network parameters of your cameras are available before you begin configuration.

The IP AutoDome defaults are as follows:

- IP Address: 192.168.0.1
- Subnet Mask: 255.255.255.0
- Gateway IP Address: 0.0.0.0

The following sections provide instructions about installing the software necessary to view images over an IP connection, configuring the IP network settings and accessing the IP AutoDome images from a Web browser.

8.4.1 Installing the Required Software

To view live video, you must install Bosch MPEG ActiveX, DirectX, and Java Virtual Machine.

To install the software:

1. Insert the IP AutoDome software CD into the CD-ROM drive of the computer.
2. Click the Windows **Start** button, select **Run**, and then **Browse** to the CD drive.
3. Open the **Install** folder, then open the **MPEG_ActiveX** folder, and double-click the **MPE-GAx.exe** file. Follow the on-screen instructions to install the Bosch MPEG ActiveX.
4. Open the **Tools** folder, then open the **DirectX9** folder, then open the **DirectX9.0c** folder, and double-click on the **dxsetup.exe** file. Follow the on-screen instructions to install DirectX.
5. Open the **Tools** folder, then open the **Java VM** folder and double-click the executable file. Follow the on-screen instructions to install Java.

8.4.2 Changing the Network Settings

The IP Module has a default IP address of 192.168.0.1. To change the IP address or any network settings, you can use the Configuration Manager software supplied on the CD or the AutoDome IP Web Server.



NOTICE! Contact your local network administrator for a valid IP address, Subnet Mask, and a Gateway IP Address.

Using Configuration Manager

Configuration Manager is an optional network utility provided on the AutoDome CD. To install the Configuration Manager software:

1. Browse to the CD and double click on the executable file. Follow the on-screen instructions to install Configuration Manager and .NET Framework if required.
2. Use the *Configuration Manager Manual* provided in the **Documentation** folder on the CD to make any configuration changes.

Using the AutoDome IP Web Server

The IP AutoDome incorporates a network video server in the IP module.



NOTICE! Depending on the PC network security settings, the user may have to add the new IP address to the browser's **trusted sites** list for the browser controls to operate.

To configure the camera using the AutoDome IP web server:

1. Set the IP address on the PC to 192.168.0.10 to ensure that the PC and the IP AutoDome are on the same Subnet.
2. Launch Microsoft Internet Explorer and navigate to the following URL:
`http://192.168.0.1`
The Web browser opens the **Livepage** for the IP AutoDome and you receive a security warning message.
3. Check the **Always Trust** box; then select **YES**.
4. Click the **Settings** link, located at the top of the Livepage.
5. Click the **Service Settings** link, located in the left pane of the Settings page.

- Click the **Network** link to open the Network Settings page.

Fig. 8.2 Network Settings Page

- Configure the settings on this page based on the addresses provided by your local network administrator.



NOTICE! Click on the **Help on this page?** link if you need more information.

- Click the **Set** button to save the settings.
- Launch another instance of Microsoft Internet Explorer.
- Type the original IP address followed by `/reset` (for example, `http://192.168.0.1/reset`) in the address bar and click **Go** to restart the IP AutoDome. Once you restart the IP AutoDome, use the new IP Address to access the **Live-page**.
- Disconnect the IP AutoDome Ethernet cable from the dedicated network switch and reconnect the Ethernet cable to the local area network (LAN).

8.5 Viewing Live Images and Controlling the AutoDome PTZ

Once the the network cables are properly connected and the IP AutoDome has a valid IP address, you can view live images and control the PTZ controls over the TCP/IP network using Microsoft Internet Explorer.

8.5.1 Establishing a Connection

Once all of the software is installed on your local computer and the IP AutoDome is configured with the proper IP addresses, you can connect to the camera using Microsoft Internet Explorer.

- Launch Microsoft Internet Explorer.
- Type the IP address of the IP AutoDome into the browser's Address Bar and click **Go**.
- If the AutoDome is password-protected, the system prompts you to enter a password.
- Type the user name and the associated password in the appropriate fields.
- Click **OK** to open the IP AutoDome Livepage. The Livepage displays the video image from the camera.



NOTICE! The IP AutoDome allows a maximum of five (5) standard connections and 25 multicast connections. If you cannot connect to the IP AutoDome, you may have exceeded the maximum number of connections for the device or network configuration.

8.5.2 Configuring Data Streams

The IP AutoDome encodes dual data streams simultaneously according to two individually customized profiles. This feature creates two (2) data streams per camera that can serve different purposes. For example, one (1) data stream for local recording and one (1) data stream optimized for transmission over the Local Area Network (LAN). In addition, the camera offers an Motion JPEG (M-JPEG) option. M-JPEG is a video format that uses JPEG picture compression in each frame of the video.

Click either the **MPEG-4 Stream 1**, **MPEG-4 Stream 2** or **M-JPEG** tab to switch between the different displays for the camera image.

8.5.3 Controlling Camera Operations

The View Control tab and the Aux Command tab allows you to control camera functions (pan, tilt, zoom, focus, and iris), navigate through on-screen menus and to view preset shots.

View Control Tab

The following figure illustrates the View Control tab and the actions that you can initiate from the tab:

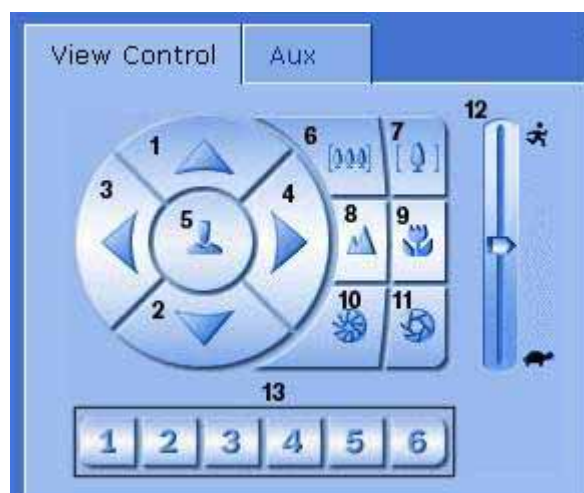

Fig. 8.3 View Control Tab

Number	Description
1	Tilts the camera up
2	Tilts the camera down
3	Pans the camera to the left
4	Pans the camera to the right
5	Pans and tilts the camera in all directions
6	Zoom out ¹
7	Zoom in ¹
8	Focus far ²
9	Focus near ²
10	Iris close ²
11	Iris open ²
12	Sets the PTZ speed for controls 1, 2, 3, 4, 5, 6, and 7
13	Moves the camera to pre-set shot numbers 1, 2, 3, 4, 5, and 6

1. This function is also accessible by using the mouse scroll wheel while in the Live video frame.

2. This button is also used as the "Enter" button to select menu items from the AUX tab.

To manually pan throughout the image area, move your cursor over any part of the live video. The image area displays a directional arrow (↶↷↸↹↺↻), then press and hold the right mouse key to pan the camera.

Digital I/O

Depending on the configuration of the IP AutoDome, the alarm relay outputs are displayed next to the camera image. The relay on the camera allows you to operate a device (for example a light or a door opener). To operate, click the relay symbol next to the video image, only if alarms are not active. The symbol is yellow when the relay is activated.

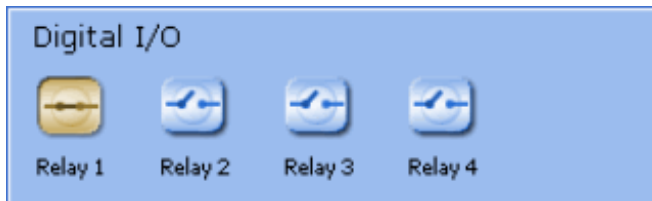

Fig. 8.4 Digital I/O Panel

System and Event Logs

The System Log field contains information about the operating status of the IP AutoDome and the connection. The Event Log contains information about alarm conditions. The following figure illustrates the System and Event logs.

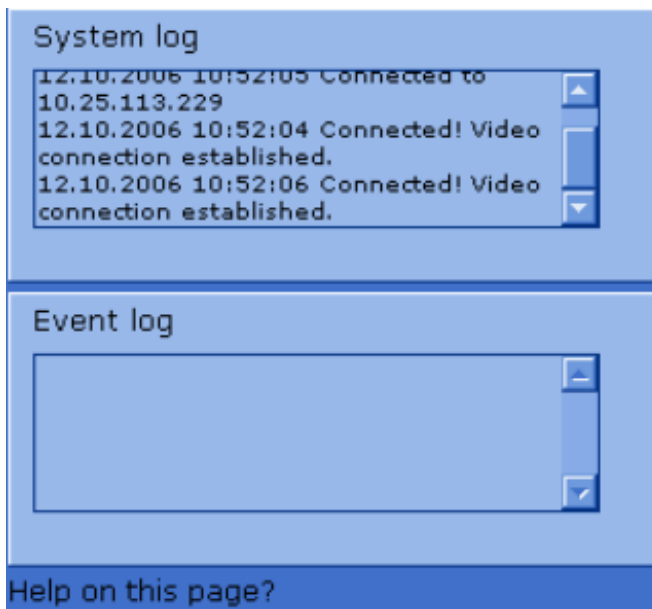

Fig. 8.5 System and Event logs

8.5.4 Entering a Keyboard Control Command

You use the Aux Control tab to enter keyboard control commands. These commands are composed of a command number plus the appropriate function key (Show Shot, Set Shot Aux On or Aux Off). A valid combination either issues a command to the camera or displays an on-screen menu.

Aux Control Tab

The Aux Control tab allows you to enter pre-programmed keyboard control commands. See *Chapter 6: Keyboard Commands by Number* on page 33 for a list of all commands. To access the Aux Control tab, navigate to the Livepage and click the Aux Control tab. The following figure illustrates this tab:

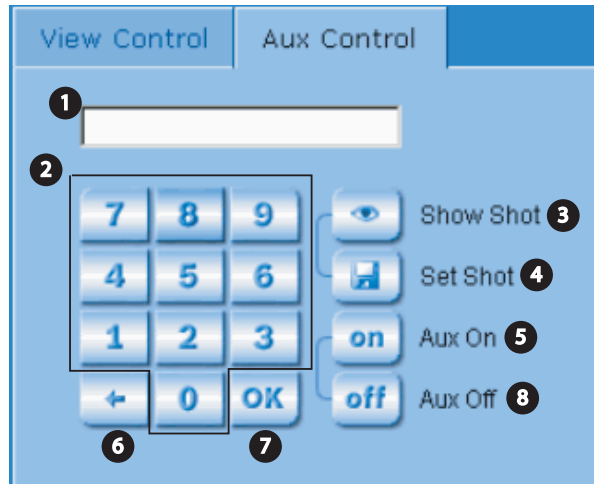

Fig. 8.6 Aux Control Tab

Number	Description
1	Command number field
2	Keypad (numbers 0-9)
3	Show a preset shot
4	Set a preset shot
5	Initiates a command
6	Deletes a number in the Command Number field
7	Used to select a menu item
8	Stops a command

To Enter a Keyboard Control Command:

1. Place the cursor in the Command Number field.
2. Click the desired command number via the on-screen keypad.
3. Click either the Aux On or the Aux Off button to initiate or stop the command. See *Chapter 6: Keyboard Commands by Number* on page 33 for a list of commands.
4. If the command initiates a menu, use the Up/Down arrows on the View Control to navigate the menu. Click the OK button to select a menu item.

To Set a Preset Shot:

Preset shots (or scenes) are camera positions that are saved in memory for future use.

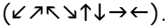
1. Move your cursor over the live image and wait for the area to display a directional arrow ()
2. Click and hold a mouse button to pan to the desired position you want to save.
3. Click any number combination from 1-99 (1-64 for a 200 series AutoDome) from the on-screen keypad to identify the scene number.
4. Click the Set Shot button. The image area displays a message that indicates which shot number was saved.

To View a Preset Shot:

1. Click the number of the scene you want to view using the on-screen keypad.
2. Click the Show Shot button.



NOTICE! For more information about the IP AutoDome settings and controls, click the **Help on this page?** link to open the IP AutoDome online help.

9 Troubleshooting Guide

Problem	Solution						
No video	<ol style="list-style-type: none"> 1. Check that the Green LED on the AutoDome CPU board is on. This LED indicates video from the camera. If the Green LED is off, then: 2. Check that the Red LED on the AutoDome CPU board is slowly blinking. This LED indicates power to the AutoDome power supply board and to the CPU Module. Red LED on AutoDome CPU Module <table border="0" style="margin-left: 20px;"> <tr> <td style="padding-right: 20px;">Flash Sequence</td> <td>Indicates:</td> </tr> <tr> <td>5 sec. on / 0.5 sec. off</td> <td>Normal operation</td> </tr> <tr> <td>Steady on</td> <td>CPU is locked</td> </tr> </table> If the Red LED is on steady, then: 3. Try cycling the AutoDome power off and on. If the Red LED is off, then: If using a Bosch Pendant Power Supply Box: 4. Check that Green LED in Power Supply Box is on. This LED indicates mains power through the transformer. If the Green LED is off, then: 5. Turn off the Power. 6. Check the FX101 fuse for mains power to the Power Supply Box. If O.K., then: 7. Check the FX102 fuse for 24 V power to the AutoDome Pendant. If O.K., then: If using a non-Bosch power supply: 8. Check that the mains power to the power supply box is on. If O.K., then: 9. Check that there is 24 V output from the transformer. 10. Check the connector on top of the AutoDome housing for bent pins. If O.K., then: 11. Check the integrity of all wires and terminal connections to the AutoDome. If O.K., then: If there is power to the AutoDome, then: 12. Remove the camera and CPU modules from the AutoDome housing and check that the Green LED on the housing power supply board is on. If the Green LED is off, then: 13. Check that the fuse on the housing power supply board is good. (Try replacing the unit, if an extra camera module is available.) 	Flash Sequence	Indicates:	5 sec. on / 0.5 sec. off	Normal operation	Steady on	CPU is locked
Flash Sequence	Indicates:						
5 sec. on / 0.5 sec. off	Normal operation						
Steady on	CPU is locked						

No camera control	<ol style="list-style-type: none"> 1. Ensure that the keyboard and monitor are set to the correct (same) camera number. If O.K., then: 2. Check that the camera address is properly set. Enter ON-997-ENTER to display the camera address. If address is not set or is incorrect, then: 3. Set the camera address using FastAddress (ON-998-ENTER). If O.K., then: 4. Check that the Amber LED on the AutoDome CPU turns on when receiving pan/tilt commands from the controller keyboard. The Amber LED indicates control is being received. Amber LED on AutoDome CPU Module <table border="0" data-bbox="492 575 1274 716"> <thead> <tr> <th data-bbox="492 575 682 604">Flash Sequence</th> <th data-bbox="789 575 906 604">Indicates:</th> </tr> </thead> <tbody> <tr> <td data-bbox="492 613 532 642">Off</td> <td data-bbox="789 613 1274 642">No incoming communications or no power</td> </tr> <tr> <td data-bbox="492 648 714 678">Solid for 2 seconds</td> <td data-bbox="789 648 1019 678">Receiving good data</td> </tr> <tr> <td data-bbox="492 684 639 714">Fast blinking</td> <td data-bbox="789 684 954 714">Lost packet(s)</td> </tr> </tbody> </table> <p>If amber LED does not light when given PTZ commands, then:</p> <ol style="list-style-type: none"> 5. Check if other cameras on the system can be controlled. If not, check the controller and wiring connections. If O.K., then: 6. Check that the RS-232/485 selector switch is properly set to the proper protocol. If O.K., then: 7. Ensure that all Biphase, Bilinx, or RS-232/485 wires are properly connected. See the <i>AutoDome Modular Camera System Installation Manual</i>. If O.K., then: 8. Check if you can access the AutoDome OSD menus (ON-46-ENTER). If O.K., then: 9. Confirm that the AutoDome passes homing (SET-110-ENTER). If AutoDome fails homing, then: 10. Contact Bosch Technical Support. 	Flash Sequence	Indicates:	Off	No incoming communications or no power	Solid for 2 seconds	Receiving good data	Fast blinking	Lost packet(s)
Flash Sequence	Indicates:								
Off	No incoming communications or no power								
Solid for 2 seconds	Receiving good data								
Fast blinking	Lost packet(s)								
Intermittent camera control	<ol style="list-style-type: none"> 1. Check that only the last AutoDome in a daisy chain configuration is terminated with a 110 Ω resistor across the +/- biphase terminals. If O.K., then: 2. Check that the maximum wire distance has not been exceeded for the control protocol (the maximum distance for RS-232 is 50 feet). See the <i>AutoDome Modular Camera System Installation Manual</i>. If O.K., then: 3. Check that all wiring meets Bosch recommended standards and specifications. See the <i>AutoDome Modular Camera System Installation Manual</i>. 								
Camera moves when moving other cameras	<ol style="list-style-type: none"> 1. Check that the camera address is properly set (ON-997-ENTER). If the camera address is not set, the AutoDome responds to control commands to any camera on the system. If camera address is not set, then: 2. Invoke the FastAddress Menu to assign a camera address (ON-998-ENTER). 								
Cannot access user settings	<p>▶ Enter the unlock command OFF-90-ENTER. This command may require a password. (Commands automatically lock in 30 minutes.)</p>								

Picture is dark	<ol style="list-style-type: none"> 1. Check that the Gain Control is set to AUTO (ON-43-ENTER). If O.K., then: 2. Check that the Auto Iris Level is set to the appropriate level (ON-11-ENTER). If O.K., then: 3. Check that the video coax is terminated with 75 Ω only at the head end. (Double termination causes dark video.) If O.K., then: 4. Go to the Camera Setup Menu and increase the Pre-Compensation setting. (This feature is available only on 300 and 500i non-IP Series AutoDomes). If O.K., then: 5. Check that the camera lens cover is removed. If O.K., then: 6. Check that the maximum coax distance has not been exceeded. See the <i>AutoDome Modular Camera System Installation Manual</i>. If O.K., then: 7. Restore all camera settings (ON-40-ENTER).
Colors are not correct	<ol style="list-style-type: none"> 1. Reset the White Balance to the appropriate selection (ON-30-ENTER). If O.K., then: 2. Go to the Camera Setup Menu and increase the Pre-Compensation setting. (This feature is available only on 300 and 500i non-IP Series AutoDomes). If O.K., then: 3. Check that the maximum coax distance has not been exceeded. See the <i>AutoDome Modular Camera System Installation Manual</i>. If O.K., then: 4. Restore the default settings (ON-40-ENTER).
Background is too bright to see subject	<ul style="list-style-type: none"> ▶ Turn on backlight compensation (ON-20-ENTER).
Video is rolling, noisy or distorted	<ol style="list-style-type: none"> 1. Ensure that the Synch Mode is set to Internal (OFF-42-ENTER). If O.K., then: 2. Check that the maximum coax distance has not been exceeded. See the <i>AutoDome Modular Camera System Installation Manual</i>. If O.K., then: 3. Check the integrity of all BNC connectors and splices. Note: Connecting a network cable to the interface board of a non-IP AutoDome causes video distortion. 4. Remove the network cable from the interface board RJ-45 connector. If O.K., then: 5. Contact Bosch Technical Support.

Day/Night camera does not switch automatically when image is dark	<ol style="list-style-type: none"> 1. Check that the Day/Night mode is set to AUTO (ON-56-ENTER). If O.K., then: 2. Set Gain Control to AUTO (ON-43-ENTER).
Inside of EnviroDome bubble is foggy	<ol style="list-style-type: none"> 1. Check the status of the Heater Module (ON-66-ENTER). If status reports Heater No Power, then: 2. Turn off the power to the AutoDome. 3. Check the FX103 fuse in the Power Supply Box for power (24 V) to the heater module. If O.K., then: 4. Check all wiring and connector pins to the heater module.
Low Voltage flashing on monitor display	<ol style="list-style-type: none"> 1. If using a non-Bosch power supply, confirm that it meets the Bosch AutoDome power ratings. See the AutoDome Datasheet for specifications. If O.K., then: 2. Check the mains input line voltage. If O.K., then: 3. Check that the maximum wire length from the power supply has not been exceeded. See the <i>AutoDome Modular Camera System Installation Manual</i>.

10 Glossary of CCTV Terms

A

Address

Each AutoDome has a numerical address in the control system in which it is located. This allows the appropriate dome to be operated. The address may be set locally using the Bilinx Configuration Tool for Imaging Devices (CTFID) or remotely using the Fast Address function (see Fast Address).

Advanced Alarm Control (AAC)

AutoDome's flexible and sophisticated alarm management subsystem that allows "rules" to be created that define which input(s) activate one or more outputs (see Alarm Rule). In its most basic form, a rule could define which input(s) should activate which output(s). In a more complex form, a rule can be programmed to take a specific keyboard command (pre-existing or not) and perform a dome function, or any combination of the above.

Advanced Diagnostics

Bosch's combination of built-in On Screen Displays (OSD) and status LEDs that are used to check critical camera parameters such as internal temperature, input voltage levels, and network connectivity. This allows a technician to quickly determine the source of problems and ensure that the dome is functioning within correct operating limits.

Aperture

The size of the opening in the iris, which controls the amount of light that reaches the CCD Sensor. The larger the F-Stop numbers, the less light reaches the sensor.

AutoBlack

A technique of boosting the video signal level to produce a full amplitude video signal even when the scene contrast is less than full range (glare, fog, mist, etc.). The darkest part of the signal is set to black and the lightest part to white, thus increasing the contrast.

AutoDome

Fully integrated, high speed, pan/tilt/zoom camera built into a protective dome housing allowing full and continuous 360° coverage of the scene.

Auto Focus

The lens continuously adjusts to the correct focus automatically for the sharpest picture.

AutoIris

The lens iris opening is automatically adjusted to allow the correct illumination of the camera sensor.

Automatic Gain Control (AGC)

The electronics that regulate the gain or amplification of the video signal.

AutoPan

The camera pans continuously between right and left limit settings.

AutoPivot

As the camera tilts through the vertical position, the camera is rotated to maintain the correct orientation of the image.

AutoPlayback

This function records the sequence of movements of the AutoDome PTZ for later playback allowing a set pattern to be repeated automatically. This function is often called Guard Tour.

AutoScaling

As the camera zooms in to increase the size of objects on the monitor screen, the pan and tilt speeds are reduced so that the relative speed on the screen remains constant for similar joystick control positions.

AutoTrack

A patented technology that integrates motion detection into the camera allowing tracking of an object and zooming in to optimize size and perspective.

Auto White Balance (AWB)

A feature that allows a color camera to automatically adjust its output color to give a natural color independent of the lighting used.

B

Back Light Compensation (BLC)

Selectively amplifies parts of the image to compensate for large contrast differences when only a portion of the image is brightly lit (e.g. a person in a sunlit doorway).

Balun (Balance Unbalanced)

A device that converts a balanced video signal (e.g. as used on twisted pair) line to an unbalanced signal (e.g. as used on coax). In a balanced line, such as twisted pair, both wires are electrically equal. In an unbalanced line such as coax, one line has different electrical properties than the other.

Billinx

A communications format that allows remote control, configuration and updates to be performed over the video cable (Coax or Passive UTP).

Biphase

Pan/Tilt/Zoom protocol for Bosch products.

C

Cable Category

Application and bandwidth rating system for UTP cabling. Categories 1 through 6 are based on EIA/TIA-568-B standards. Category is typically abbreviated CAT. UTP Category 5, 5e, and 6 are used for Ethernet data cabling applications. Ethernet wiring distances are limited to a maximum of 100m (328ft.) when using UTP wiring.

Cable Compensation

A technology that prevents image degradation caused by signal losses when transmitting video over long cable lengths.

CCD Format

Indicates the size of the camera sensor used. In general, the larger the sensor, the more sensitive the camera and the better the image quality. The format is quoted in inches, for example 1/4" or 1/3". See Charge Coupled Device (CCD).

CCD (Charge Coupled Device)

The most common type of solid state image sensor used in CCTV cameras. The sensor converts light energy into electrical signals.

CCTV (Closed Circuit TeleVision)

A video system that transmits television signals over a closed (non-broadcast) system.

Color Temperature

A measure of the relative color of illumination. Most generally used to specify the automatic correction range of a color camera.

CTFID (Configuration Tool for Imaging Devices)

Bosch software used to configure and update cameras and other remote devices over video cable using Bilinx, and to save them for later use.

D

Day/Night (IR sensitive)

An AutoDome that has normal color operation in situations where there is sufficient illumination (day conditions), but where the sensitivity can be increased when there is little light available (night conditions). This is achieved by removing the infrared cut filter required for good color rendition. The sensitivity can be further enhanced by integrating a number of frames to increase the signal to the noise ratio of the camera.

Default Shutter

This feature allows the shutter speed to be set to a fast speed to eliminate motion blur and providing detailed and clear image of fast-moving objects while there is sufficient light. When light levels fall and other adjustments have been exhausted, the shutter speed reverts to the standard setting to maintain sensitivity.

Digital Image Stabilization

See Image Stabilization.

DNR (Dynamic Noise Reduction)

A digital video processing technique that measures the noise (image artifacts) in the picture and automatically reduces it.

E

Ethernet

The most commonly used local area network (LAN) access method. Ethernet complies with the IEEE 802.3 standard. The Ethernet standard supports 10 Mbps, 100 Mbps and 1000 Mbps (Gigabit) data transmission rates.

EnviroDome

AutoDome with environmental protection that allows it to be used outdoors in almost any climate.

F

Fast Address

A system for setting the address of the AutoDome remotely from the control system.

Fiber Optic Transmission

Refers to the transmission of video and/or data via optical fibers. Optical fibers are thin glass strands that are designed for light wave transmission. Video and data are digitized and transformed into a series of light pulses. The use of fiber optics for video and data transmission offers several advantages over sending electrical signals across copper wires. First, light pulses are not affected by random radiation in the environment, and thus their error rate is far lower. Fiber optics span far greater distances without need for repeaters or signal regenerators, and are far more secure as they are more difficult to tap and taps in the line can be detected. Optical fiber also provides enormous bandwidth with a single fiber capable of transmitting trillions of bits per second. There are two primary types of optical fiber; singlemode and multimode. Singlemode fiber is used when large distances must be spanned, typically greater than 2 Km/1.2 miles (see Singlemode). Multimode is typically used to span smaller distances such as the inside of buildings or on small campuses (see Multimode).

Field of View

The measure of the visible area within the camera's field of view. The larger the focal length, the smaller the field of view. The smaller the focal length, the wider the field of view.

Focal Length

The distance from the optical center of the lens to the image of an object located at an infinite distance from the lens. Long focal lengths give a small field of view (e.g. telephoto effect), while short focal lengths give a wide angle view.

F-Number

The standard measure of the lens aperture, which is the iris diameter, divided by the focal length of the lens. The lower the maximum aperture (or F-Number), the more light that passes through the lens.

F-Stop

See F-Number.

G

Gateway Address

A node on a network that serves as an entrance to another network.

Guard Tour

Allows recorded tours with a combined duration of 15 minutes. Recorded tours consist of control commands and can be played back as needed. All camera position information is stored for maximum flexibility (including pan, tilt, zoom, etc.).

H

Hybrid Streaming

The ability to simultaneously stream IP video across a local or wide area network, and CVBS video via coaxial or fiber optic cabling.

I

Image Stabilization

An algorithm that virtually eliminates camera shake in both the vertical and horizontal axes, resulting in exceptional image clarity.

Infrared Illumination

Electromagnetic radiation (light) with a longer wavelength than is visible to the naked eye. IR illumination is prominent at dusk and dawn and in incandescent lamps. IR illuminators come in the form of lamps with the appropriate filters, LEDs, or lasers. CCD sensors are less sensitive to IR than visible light, but IR can significantly increase the total illumination level, leading to a much better image at low light levels.

IP 66

The IP code (Ingress Protection) indicates the degree of protection provided by enclosures for electrical equipment. The first number indicates protection of internal equipment against the ingress of solid foreign objects. The second number indicates protection of internal equipment against harmful ingress of water. Higher digits refer to higher levels of protection. See also NEMA rating.

IP Address

The address of a device attached to an IP network. Each device on an IP network must use a unique address. Every IP data packet contains a source address (sender) and a destination address (recipient). Each IP address consists of 32-bits that are arranged into four 8-bit "octets" (x.x.x.x). IP addresses range from 0.0.0.0 to 255.255.255.255.

IPS (Images Per Second)

A measurement of the rate that pictures are displayed to create a video stream. A rate of 25 IPS (PAL) or 30 IPS (NTSC) is generally considered to be full motion video.

IRE (Institute of Radio Engineers)

A measurement of video amplitude that divides the area from the bottom of sync to peak white level into 140 equal units. 140 IRE equals 1V peak to peak. The range of active video is 100 IRE.

L

Lux

The International (SI) unit of measurement of the intensity of light. It is equal to the illumination of a surface one meter away from a single candle.

M

MJPEG

Motion JPEG is a digital video encoding standard where each video frame is separately compressed into a JPEG image.

Modal Dispersion (or Intermodal Dispersion)

A broadening of a waveform over long distances. Modal dispersion occurs in multimode fibers, because light is bounced down different reflective paths (e.g. modes) in the fiber. As the distance increases, the path (mode) begins to spread and the arrival time for the different light rays begins to vary. A large variance (dispersion) increases the chance that the optical receiver may interpret the incoming signals incorrectly. Modal dispersion is a major problem with multimode fibers.

MPEG-4

A digital video encoding and compression standard that uses interframe encoding to significantly reduce the size of the video stream being transmitted. With interframe coding, a video sequence is made up of keyframes that contain the entire image. In between the keyframes are delta frames, which are encoded with only the incremental differences. This often provides substantial compression because in many motion sequences, only a small percentage of the pixels are actually different from one frame to another.

Multimode Fiber

An optical fiber with a larger core (typically 50 or 62.5 microns) than singlemode fiber. The core can be made of plastic or glass fibers and it is the most commonly used fiber for short distances such as LANs. The name multimode comes from the fact that light rays travel down multiple reflective paths (modes) within the fiber. This allows light to enter the core at different angles, making it easier to connect to broader light sources such as LEDs (light emitting diodes). Fiber optic interfaces and multimode fiber-based transmission systems are less expensive than those based on singlemode fiber. However, the use of multiple reflective paths (modes) increases modal dispersion (see Modal Dispersion) and shortens the distances that this type of fiber optic transmission system can span.

Multi-Protocol

A protocol is a convention or standard that controls or enables the connection, communication, and data transfer between two devices. In PTZ cameras such as the AutoDome, protocol refers to the standard used to control the pan, tilt, and zoom (PTZ) operation of the camera. Since each dome camera manufacturer's PTZ protocols are unique, multi-protocol support is needed to support third party dome systems. AutoDome cameras support the Pelco "D" and "P" protocols and well as Bosch's own biphasic protocol (See Biphasic).

N

NEMA (National Electrical Manufacturers Association) Rating

Specification standards in reference to the operating environment for a variety of electrical devices.

NightSense

A method of boosting the sensitivity of high-resolution Bosch color cameras by 9db (a factor of 3) by combining the signal of the color image in a single monochrome picture.

NPT (National Pipe Thread)

A U.S. standard for tapered threads. NPT sizes measure the nominal inside diameter of the pipe. NPT threads form a seal as the threads compress against each other.

O

OSD (On-Screen Display)

Menus are shown on the display monitor.

P

Pan

Camera movement in the horizontal direction.

Pixel

The smallest addressable unit on a display screen or bitmapped image.

Pre-Position

A pre-selected and stored combination of pan, tilt and zoom positions that allow a set view to be recalled. Also known as Preset Shot.

Preset Tour

A sequence of preset shots combined to provide a pre-programmed tour of the area covered by an AutoDome camera.

Pressurized Dry Nitrogen Housing

A housing for outdoor applications that protects against smog, humidity, dirt and dust.

Privacy Masking

The ability to mask out a specific area to prevent it being viewed.

R

Region of Interest

The defining of a specific area within a field of view to be used by the motion detection algorithm to only look for motion within this region.

Resolution

The measure of the fine detail that can be seen in an image. For analog systems this is typically measured in Television Lines or TVL. The higher the TVL rating, the higher the resolution.

RS232/485

A communication interface for third party control and firmware upgrades to the AutoDome products.

Rule

AutoDome's alarm management subsystem that uses "if this, do that" rules to perform specific actions when an event occurs.

S

Sector Blanking

The ability to blank out video in any of the 16 pan sectors.

Sensitivity

A measure of the amount of light required to provide a standard video signal. Sensitivity values are stated in lux or foot-candles.

SensUp

Increases camera sensitivity by increasing the integration time on the CCD. This is accomplished by integrating the signal from a number of consecutive video frames to reduce signal noise.

Singlemode Fiber

An optical fiber with a silica (e.g. glass) core with a diameter of less than 10 microns. Used for high-speed transmission over long distances, it provides greater bandwidth than multimode, but its smaller core makes it more difficult to couple the light source. Singlemode fiber optic transmission systems use more expensive laser-based light sources.

Spot Focus

Activates Auto Focus for three seconds after camera movement.

Subnet Mask

Subnetting is a method that allows one large network to be broken down into several smaller ones. Depending on the network class (A, B, or C), some number of IP address bits are reserved for the network address (subnet) and some for the host address. For example, Class A addresses use 8 bits for the subnet address and 24 bits for the host portion of the address. Class A subnet masks are denoted 255.0.0.0. Class B addresses (16 bits for both the subnet and host address) use a 255.255.0.0 subnet mask. Class C addresses (8 bits for the subnet and 24 bits for the host address) use a subnet mask of 255.255.255.0.

T

TCP/IP (Transmission Control Protocol/Internet Protocol)

A communications protocol suite that provides two data transport methods. TCP is a connection-based protocol that ensures that data arrives intact and complete. UDP is a connectionless, best effort protocol that simply sends out packets. UDP is typically used for streaming media, while TCP is used when error-free delivery is required.

Tilt

Camera movement in the vertical direction.

Tri-streaming

A Bosch encoding technology that generates two separate MPEG-4 video streams and one MJPEG stream simultaneously. This advanced streaming capability enables the user to tune live viewing and recording requirements independently to meet specific site and enterprise requirements.

U

UTP (Unshielded Twisted Pair)

A variant of twisted pair cabling UTP cable is not surrounded by any shielding. The wires in a twisted pair cable are twisted around each other to minimize interference from the other twisted pairs in the cable. UTP is the primary wire type for telephone usage and the most commonly used type of networking cable.

V

Virtual Masking

A unique Bosch technology that allows for the creation of “invisible” motion masking areas. These invisible masks are similar to privacy zones, but only the AutoDome’s AutoTrack II and Video Motion Detection algorithms can see them. This allows the AutoDome to ignore areas of unwanted motion.

VMD (Video Motion Detection)

An algorithm for motion detection in which the camera compares the current image with a reference image and counts the number of pixels (see Pixel) that have changed between the two images. An alarm is generated when the number of pixel changes exceeds a user-configured threshold.

X

XF-Dynamic

A highly accurate 15-bit digital signal processing technology from Bosch that extends the dynamic range of Dinion^{XF} cameras to optimally capture the detail in both the high and low light areas of the scene simultaneously, maximizing the information visible in the picture.

Z

Zoom

Changing the effective focal length to allow different fields of view to fill the picture area. Zoom can be optical, where the lens is adjusted, or digital, where a portion of the view selected is magnified electronically.

Index

Symbols

#-ENTER 4

/reset 43

Numerics

33-PRESET 26

34-PRESET 26

92-PRESET 26

93-PRESET 26

94-PRESET 26

95-PRESET 26, 27

96-PRESET 26

97-PRESET 26

98-PRESET 26

99-PRESET 26

A

ack 27, 31

acknowledge 27

acknowledge alarm 31

adjusting

AutoDome orientation 12

brightness 14

camera height 21

vertical position 14

Advanced 38

Advanced Feature Setup menu 8, 21

camera height 21

virtual masking 21

AES 10

alarm relay 17

alarm relay outputs 45

alarm status 22

Alarms Setup menu 8, 16

input setup 16

inputs (1-7) 16

normally closed dry contact 16

normally closed supervised contact 16

normally open dry contact 16

normally open supervised contact 16

inputs (8-12) 16

AutoTrack 16

Aux Off 16

Aux On 16

motion detection 16

Shot 16

ATW 9

audio 39

auto focus 11

auto iris 11

auto iris level 11

Auto SensUP 10

autobaud 15, 25

AutoDome

IP

/reset 43

audio 39

controlling 43

dual streaming 39

encoding 39

gateway address 41

IP address 41

Livepage 42

multicast 39

network settings page 43

port 41

record 39

snapshots 39

subnet mask 41

system requirements 40

viewing live images 43

AutoDome orientation 12

automatic white balance 9

autopan 12, 23

AutoPivot 12, 27, 30

AutoScan 12, 26

AutoSensUP maximum 10

AutoTrack 16, 17

Aux Control tab 44, 46

Aux Off 46

Aux Off command 16, 17

Aux On command 16, 17, 46

AWB hold 9

B

backlight compensation 10

baud rate 15

Bilinx 15

BIST 22

Bosch menu 27, 28

Bosch MPEG ActiveX 40, 42

built-in self test 22

C

camera

height 21

operations 44

OSD 14

setup 27

Camera Setup menu 8, 9, 29

AutoSensUP maximum 10

backlight compensation 10

gain control 9

line lock delay 9

line lock 9

maximum gain level 9

night mode 10

color 10

threshold 10

pre-composition 10

sharpness 9

shutter 10

synchronization menu 9

synchronization mode

crystal 9

line lock 9

white balance 9

ATW 9

AWB hold 9

extended ATW 9

indoor white balance 9

outdoor white balance 9

changing passwords 5

- command lock 27
- Command Lock menu 28
- command number 46
- commands
 - #-ENTER 4
 - /reset 43
 - 33-PRESET 26
 - 34-PRESET 26
 - 92-PRESET 26
 - 93-PRESET 26
 - 94-PRESET 26
 - 95-PRESET 26, 27
 - 96-PRESET 26
 - 97-PRESET 26
 - 98-PRESET 26
 - 99-PRESET 26
 - autopan 23
 - AutoScan 26
 - Aux Off 16, 17, 46
 - Aux On 16, 17, 46
 - clear 23
 - FastAddress 26
 - inactivity operation 24
 - keyboard 33, 46
 - limit stops 26
 - OFF-90-ENTER 5, 24
 - ON-997-ENTER 4
 - ON-998-ENTER 4
 - ON-999-ENTER 4
 - ON-9-ENTER 24
 - Pelco 26
 - random scan 26
 - Pelco frame scan 26
 - PRESET 26
 - preset shot 23, 47
 - preset tour 26
 - recording tours 24
 - Set 23
 - set 23
 - Set Shot 46, 47
 - SET-100-ENTER 23
 - SET-802-ENTER 5
 - Shot 16, 23
 - shot 23
 - Show Shot 46
 - store 23
 - synchronization mode 26
 - unlocked 23
 - user commands 23
 - zero pan 26
- Communication Setup menu 8, 15
 - autobaud 15
 - baud rate 15
 - Bilinx 15
- Configuration Manager 42
- Configuration Tool 22
- Configuration Tool for Imaging Devices 22
- configuring
 - alarms 8
 - camera height 21
 - IP AutoDome
 - /reset 43
 - Livepage 42
 - network settings 43
 - rules 18
 - constant focus 11
 - constant iris 11
 - controlling
 - camera operations 44
 - focus 44
 - image area 45
 - iris 44
 - PTZ 44
 - zoom 44
 - Crop Video 38
 - crop video 38
 - CTFID access 22
 - custom tour
 - editing 24
 - playback 24
 - recording 24
 - setting dwell time 24
 - Tour Period menu 24
 - custom tour 2 24
- D**
- defining
 - command outputs 17
 - input commands 16
 - physical inputs 16
 - physical outputs 17
 - rules 18
- Diagnostic menu 8, 22
 - alarm status 22
 - BIST 22
 - CTFID access 22
 - high temperature events 22
 - homing events 22
 - homing failed 22
 - internal temperature 22
 - low temperature events 22
 - low volt events 22
 - power up events 22
 - restart events 22
 - security access 22
 - video loss events 22
- diagnostics 22
- Dibos 40
- digital I/O 45
- digital zoom 11
- DirectX 40, 42
- display adjust 14
- Display Setup menu 8, 14
 - camera OSD 14
 - display adjust 14
 - privacy masking 14
 - sector blanking 14
 - title OSD 14
- displaying
 - camera response information 14
 - on-screen menus 46
 - sector titles 14
 - shot titles 14
 - software version 31

- titles 14
- dual streaming 39
- dwell period 24
- dwell time 12
- dxsetup.exe 42

E

- editing
 - custom tour 30
 - password 27, 31
 - presets 30
 - standard tour 30
- encoding 39
 - video 39

Ethernet

- cable 40, 43

- event log 45

- extended ATW 9

F

- FastAddress 26, 27, 31

files

- dxsetup.exe 42
- JPEG 39
- M-JPEG 44
- MPEG-4 40
- MPEG4x.exe 42

- focus 44

- focus speed 11

- freeze frame on preposition 13

G

- gain control 9

- gateway address 41

H

- high temperature

- events 22
- threshold 22

- homing

- events 22
- failed 22

I

- IGMP V2 39

- image stabilization 38

- inactivity 12

- accessing 24
- mode 24
- operation 24
- period 12

- Inactivity Mode menu 24

- indoor white balance 9

- input commands 16

- inputs (1-7) 16

- inputs (8-12) 16

- inputs setup 16

- internal 26

- internal temperature 22

- IP 39

- address 41, 42
- module 39

- iris 44

- iris speed 11

J

- Java VM 42

- JPEG 39

K

- keyboard commands 33, 46

- #-ENTER 4

- Aux Off 16, 17

- Aux Off command 46

- Aux On 16, 17, 46

- OFF-90-ENTER 5, 24

- ON-997-ENTER 4

- ON-999-ENTER 4

- ON-9-ENTER 24

- Set 23

- SET-100-ENTER 23

- SET-802-ENTER 5

- Shot 23

- keypad 46

L

- Language menu 8, 20

- Lens Setup menu 8, 11

- auto focus 11

- constant focus 11

- manual focus 11

- spot focus 11

- auto iris 11

- constant iris 11

- manual iris 11

- auto iris level 11

- digital zoom 11

- focus speed 11

- iris speed 11

- maximum zoom speed 11

- limit stops 26, 27, 30

- line lock 9, 26

- line lock delay 9

- Livepage 42, 43

- low temperature

- events 22

- threshold 22

- low volt events 22

M

- manual

- focus 11

- iris 11

- masking

- privacy 14

- virtual 21

- maximum gain level 9

- maximum zoom speed 11

- menus 7

- Advanced Feature Setup 8, 21

- Alarms Setup 16

- Camera Setup 9, 29

- Communication Setup 15

- Diagnostic 22

- Display Setup 14

- Inactivity Mode 24

- Language 20

- Lens Setup 11

- other 30, 31
- Outputs Setup 17
- Pelco 27
 - Bosch 28
 - Command Lock 28
 - Setup 27
- Pelco Setup 26
- PTZ Setup 12, 30
- Rule Setup 18
- Setup 28
- Tour Period 24
- M-JPEG 44
- motion detection 16
- MPEG-4 40
- MPEG-4 Stream 1 44
- MPEG-4 Stream 2 44
- MPEGActiveX 42
- MPEGAx.exe 42
- multicast 39
- N**
- network settings page 43
- networking
 - baud rate 15
 - Ethernet cable 40
 - gateway address 41
 - IGMP V2 39
 - IP 39
 - IP address 41
 - port 41
 - subnet mask 41
 - TCP/IP 39
 - UDP 39
- night mode 10, 29
 - color 10
 - threshold 10
- normally closed circuit 17
- normally closed dry contact 16
- normally closed supervised contact 16
- normally open circuit 17
- normally open dry contact 16
- normally open supervised contact 16
- O**
- OFF-90-ENTER 5, 24
- ON-997-ENTER 4
- ON-998-ENTER 4
- ON-999-ENTER 4
- ON-9-ENTER 24
- on-screen display 7, 14, 17
- OSD 7, 14, 17
- outdoor white balance 9
- outputs (1-3) 17
- outputs (5-12) 17
- Outputs Setup menu 17
 - alarm relay 17
 - outputs (1-3) 17
 - normally closed circuit 17
 - normally open circuit 17
 - outputs (5-12) 17
 - AutoTrack 17
 - Aux Off 17
 - Aux On 17

- OSD 17
- transmit 17

P

- passwords
 - security level 5
- Pelco 25, 27
 - frame scan 26
 - keyboard commands 26
 - 33-PRESET 26
 - 34-PRESET 26
 - 92-PRESET 26
 - 93-PRESET 26
 - 94-PRESET 26
 - 95-PRESET 26, 27
 - 96-PRESET 26
 - 97-PRESET 26
 - 98-PRESET 26
 - 99-PRESET 26
 - AutoScan 26
 - FastAddress 26
 - limit stops 26
 - Pelco frame scan 26
 - Pelco random scan 26
 - PRESET 26
 - preset tour 26
 - synchronization mode 26
 - zero pan 26
- menus 27
 - Bosch 28
 - Camera Setup 29
 - night mode 29
 - white balance 29
 - Command Lock 28
 - other 30, 31
 - ack 31
 - acknowledge alarm 31
 - FastAddress 31
 - password 31
 - reset alarm 31
 - software version 31
 - PTZ Setup 30
 - AutoPivot 30
 - edit custom tour 30
 - edit standard tour 30
 - limit stops 30
 - presets 30
 - recordings 30
 - scan speed 30
 - Setup 27
 - ack alarm 27
 - Bosch menu 27
 - camera setup 27
 - command lock 27
 - edit password 27
 - FastAddress 27
 - PTZ setup 27
 - reset alarm 27
 - software version 27
- Mode 38
- mode 25
- PRESET command 26

- protocol 25
- random scan 26
- Setup menu 26
- Pelco protocol
 - address guidelines 26
 - Pelco-D 25
 - Pelco-P 25
- Pelco-D 25
- Pelco-P 25
- physical inputs 16
- playback
 - custom tour 24
 - standard tour 24
- port 41
- power up events 22
- pre-composition 10
- preposition tours 23
 - custom 23
 - standard 23
- preset shot 23, 47
- preset tour 26
- previous Aux 12
- privacy masking 14
- protocol
 - Bilinx 15
 - IGMP V2 39
 - Pelco 25
 - Pelco-D 25
 - Pelco-P 25
 - TCP/IP 39
 - UDP 39
- PTZ
 - control 44
 - fixed speed 12
 - setup 8, 27
- PTZ Setup menu 12, 30
 - AutoDome orientation 12
 - autopan 12
 - AutoPivot 12
 - AutoScan 12
 - freeze frame on preposition 13
 - inactivity 12
 - previous Aux 12
 - scene 1 12
 - inactivity period 12
 - PTZ fixed speed 12
 - tilt up limit 13

R

- record 39
- recorded tour 24
- recording 30
- reset alarm 27, 31
- restart events 22
- rule (1-12) 18
- rule choices
 - enabled 19
 - input 19
 - Aux Off 19
 - Aux On 19
 - Shot 19
 - output 19

- alarm relay 19
- Aux Off 19
- Aux On 19
- follows 19
- OSD 19
- Shot 19
- transmit 19

- Rule Setup menu 18
- rule status 18
- rules 18

S

- scan speed 27, 30
- scene 1 12
- sector blanking 14
- security access 22
- security level 5
- SensUp 10
- set command 23
- Set Shot 46, 47
- SET-100-ENTER 23
- SET-802-ENTER 5
- settings
 - AutoDome orientation 12
 - autopan 23
 - brightness 14
 - camera height 21
 - inactivity mode 24
 - passwords 5
 - preposition tours 23
 - preset shot 23
 - rules 18
 - sharpness 9
 - vertical position 14
- Setup menu 7, 26, 27, 28
 - Advanced Feature Setup 8
 - Alarms 8
 - Camera 8
 - Communication 8
 - Diagnostic 8
 - Display 8
 - Language 8
 - Lens 8
 - PTZ 8
- sharpness 9
- shot
 - clear 23
 - set 23
 - store 23
 - view 23
- Show Shot command 46
- shutter 10
- Shutter Mode 10
- snapshots 39
- software
 - Bosch MPEG ActiveX 42
 - DirectX 40, 42
 - dxsetup.exe 42
 - MPEGActiveX 42
 - MPEGAx.exe 42
- software version 27, 31
- special passwords 5

- spot focus 11
- standard tour
 - playback 24
 - setting dwell time 24
 - Tour Period menu 24
- standard Tour 1 24
- standard tour 1 23
- standard tour A 24
- subnet mask 41
- synchronization mode 9, 26
- System Log 45
- system log 45

T

- TCP/IP 39
- tilt up limit 13
- title OSD 14
- titles 14
 - brightness 14
 - vertical position 14
- tour
 - custom 30
 - periods 27
 - preset 26
 - standard 30
- tour 1 23
 - period 12, 30
- tour 2 23
 - period 12
- Tour 2 Period 30
- Tour Period menu 24

U

- UDP 39
- user commands 23

V

- video loss events 22
- VIDOS 40
- View Control tab 44
- VIP XD 40
- virtual masking 21
- voltage limit 22

W

- white balance 9, 29

Z

- zero pan 26
- zoom 44

A User Commands by Number

Function Key	Comm No.	Command	Description	Series 200	Series 300	Series 500i
On/Off	1	Scan 360°	Autopan without limits	✓	✓	✓
On/Off	2	Autopan	Autopan between limits	✓	✓	✓
On/Off	7	Play Custom Pre-position Tour	Activate/Deactivate		✓	✓
On/Off	8	Play Pre-position Tour	Activate/Deactivate	✓	✓	✓
On/Off	14	Set Autopan and Scan Speed	On–increase Off–decrease or adjust slide bar	✓	✓	✓
On/Off	15	Set Pre-position Tour Period (dwell)	On–increase dwell Off–decrease dwell	✓	✓	✓
On/Off	20	Backlight Comp	Backlight Compensation	✓	✓	✓
On/Off	24	Stabilization	Electronic Stabilization			✓
On	47	View Factory Settings	View all menu default settings	✓	✓	✓
On/Off	50	Playback A, continuous	Activate/Deactivate		✓	✓
On/Off	51	Playback A, single	Activate/Deactivate		✓	✓
On/Off	52	Playback B, continuous	Activate/Deactivate		✓	✓
On/Off	53	Playback B, single	Activate/Deactivate		✓	✓
On/Off	56	Night Mode menu	On, Off, Auto (Day/Night only)	✓	✓	✓
On/Off	57	Night Mode setting	On, Off, Auto (Day/Night only)	✓	✓	✓
On	62	Pre-position Title menu	Enters Pre-position Title menu	✓	✓	✓
On	64	Alarm Status	Enters Alarm Status menu		✓	✓
Off	65	Alarm Acknowledge	Acknowledge alarm or deactivate physical outputs		✓	✓
On	66	Display software version	Displays software version number	✓	✓	✓
On	72	Re-initialize camera	Performs camera/lens re-initialization functions	✓	✓	✓
On/Off	78	AutoTrack	Turns AutoTrack on or off			✓
On/Off	81	Physical output 1	On–activates output Off–deactivates output		✓	✓
On/Off	82	Physical Output 2	On–activates output Off–deactivates output		✓	✓
On/Off	83	Physical Output 3	On–activates output Off–deactivates output		✓	✓
On/Off	90	Command Lock/Unlock	On–lock on Off–lock off	✓	✓	✓
On/Off	100	Record A	Activate/Deactivate		✓	✓
On/Off	101	Record B	Activate/Deactivate		✓	✓
On	997	FastAddress, display	Display current address	✓	✓	✓
On	998	FastAddress, all units	Display and program current address	✓	✓	✓
On	999	FastAddress, unaddressed domes	Display and program unaddressed AutoDomes	✓	✓	✓
Set	"1-99"	Pre-position programming	Set ##–programs a preset view	"1-64"	✓	✓
Shot	"1-99"	Pre-position recall	Shot ##–recall programmed preset	"1-64"	✓	✓
Set	100	Pre-position menu	Enters the Pre-position menu	✓	✓	✓
Set/Shot	101	Autopan left limit	Set–programs left limit Shot–shows limit	✓	✓	✓
Set/Shot	102	Autopan right limit	Set–programs right limit Shot–shows limit	✓	✓	✓
Set	110	Factory P/T home position	Set–recalibrate home position	✓	✓	✓
Set	900	Edit Tour 1 (Standard)	Enters the Standard Tour Scene menu		✓	✓
Shot	900	Edit Tour 2 (Custom)	Enters the Custom Tour Scene menu	✓	✓	✓
Set/Shot	901-999	Adds/Removes a preposition shot from Tour 1	Set ###–adds preset Shot ###–removes preset	901-964	✓	✓

Americas:

Bosch Security Systems
130 Perinton Parkway
Fairport, New York, 14450
USA

Phone +1 800 289 0096
Fax +1 585 223 9180

www.boschsecurity.us

© Bosch Security Systems, Inc., 2006

Europe, Middle East, Asia:

Bosch Security Systems B.V.
Postbus 80002
5600 JB Eindhoven

Phone: +31 40 2577 200
Fax: +31 40 2577 202

nl.securitysystems@bosch.com
www.boschsecurity.nl

www.boschsecurity.com

Asia-Pacific:

Bosch Security Systems Pte Ltd.
38C Jalan Pemimpin
Singapore 577180

Phone +65 6319 3450
Fax +65 63139 3499

www.boschsecurity.com