

CEILING CASSETTE SPLIT TYPE AIR CONDITIONER

INSTALLATION MANUAL





INSTALLATION MANUAL

This manual provides the procedures of installation to ensure a safe and good standard of operation for the air conditioner unit.

Special adjustment may be necessary to suit local requirements.

Before using your air conditioner, please read this instruction manual carefully and keep it for future reference.

CEILING CASSETTE SPLIT TYPE AIR CONDITIONER

MODEL

COOLING ONLY

CK20A / ACK20A / YCK20A
SL20B / ALC20B / YSL20B

CK25A / ACK25A / MCK025A / YCK25A
SL25B / ALC25B / MLC025B / YSL25B

CK30A / ACK30A / MCK030A / YCK30A
SL30C / ALC30C / MLC30C / YSL30C

CK40A / ACK40A / MCK040A / YCK40A
SL40C / ALC40C / MLC040C / YSL40C

CK50A / ACK50A / MCK050A / YCK50A
SL50C / ALC50C / MLC050C / YSL50C

HEAT PUMP

CK20AR / ACK20AR / MCK020AR / YCK20AR
SL20BRK / ALC20BRK / MLC020BRK / YSL20BRK

CK25AR / ACK25AR / MCK025AR / YCK25AR
SL25BRK / ALC25BRK / MLC025BRK / YSL25BRK

CK30AR / ACK30AR / MCK030AR / YCK30AR
SL30CR / ALC30CR / MLC030CR / YSL30CR

CK40AR / ACK40AR / MCK040AR / YCK40AR
SL40CR / ALC40CR / MLC040CR / YSL40CR

CK50AR / ACK50AR / MCK050AR / YCK50AR
SL50CR / ALC50CR / MLC050CR / YSL50CR



CONTENTS

- Safety Precautions	page 2	- Accessory Parts	page 13
- Installation Diagram	page 3	- Indicator Lights	page 14
- Outline And Dimensions	page 4	- Overall Checking	page 15
- Installation of Indoor Unit	page 5	- Standard Operation Conditions	page 15
- Installation Of Outdoor Unit	page 9	- Auto Random Re-start Function	page 15
- Refrigerant Piping Work	page 9	- Service And Maintenance	page 16
- Electrical Wiring Connection	page 10	- Trouble Shooting	page 16
- Vacuuming and Charging	page 13		

SAFETY PRECAUTIONS

Before installing the air conditioner unit, please read the following safety precautions carefully.

Warning





- Installation and maintenance should be performed by qualified persons who are familiar with local code and regulation, and experienced with this type of appliance.
- All field wiring must be installed in accordance with the national wiring regulation.
- Ensure that the rated voltage of the unit corresponds to that of the name plate before commencing wiring work according to the wiring diagram.
- The unit must be GROUNDED to prevent possible hazard due to insulation failure.
- All electrical wiring must not touch the refrigerant piping or any moving parts of the fan motors.
- Confirm that the unit has been switched OFF before installing or servicing the unit.

IMPORTANT

DO NOT INSTALL OR USE THE AIR CONDITIONER UNIT IN A LAUNDRY ROOM.

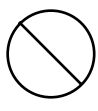
Caution

Please take note of the following important points when installing.

- **Do not install the unit where leakage of flammable gas may occur.**
 If gas leaks and accumulates around the unit, it may cause fire ignition.
- **Ensure that the drainage piping is connected properly.**
 If the drainage piping is not connected properly, it may cause water leakage which will dampen the furniture.
- **Do not overcharge the unit.**
 This unit is factory pre-charged. Overcharge will cause over-current or damage to the compressor.
- **Ensure that the units panel is closed after service or installation.**
 Unsecured panels will cause the unit to operate noisily.



INSTALLATION DIAGRAM

Wireless Remote Control

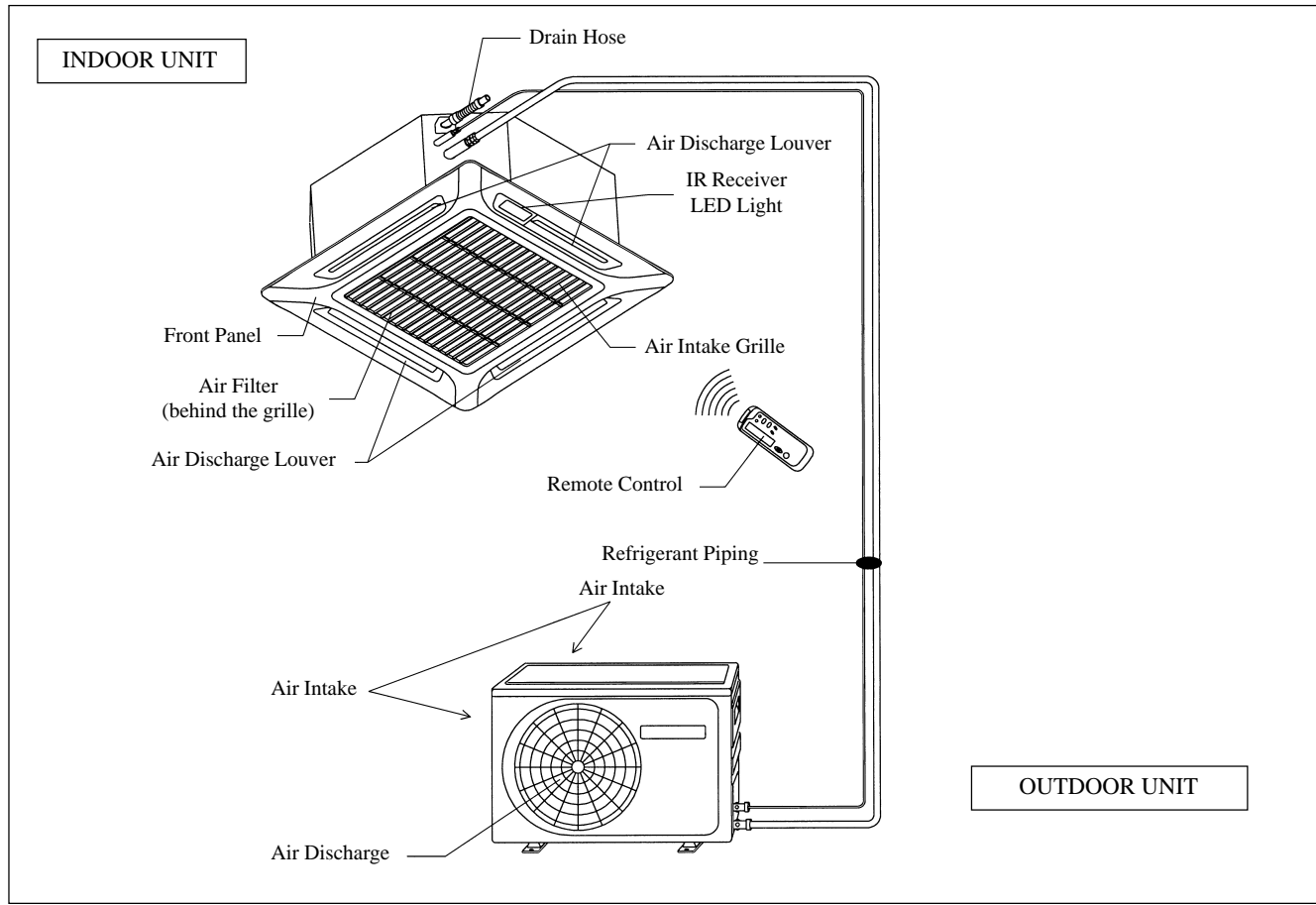

English

Wired Remote Control

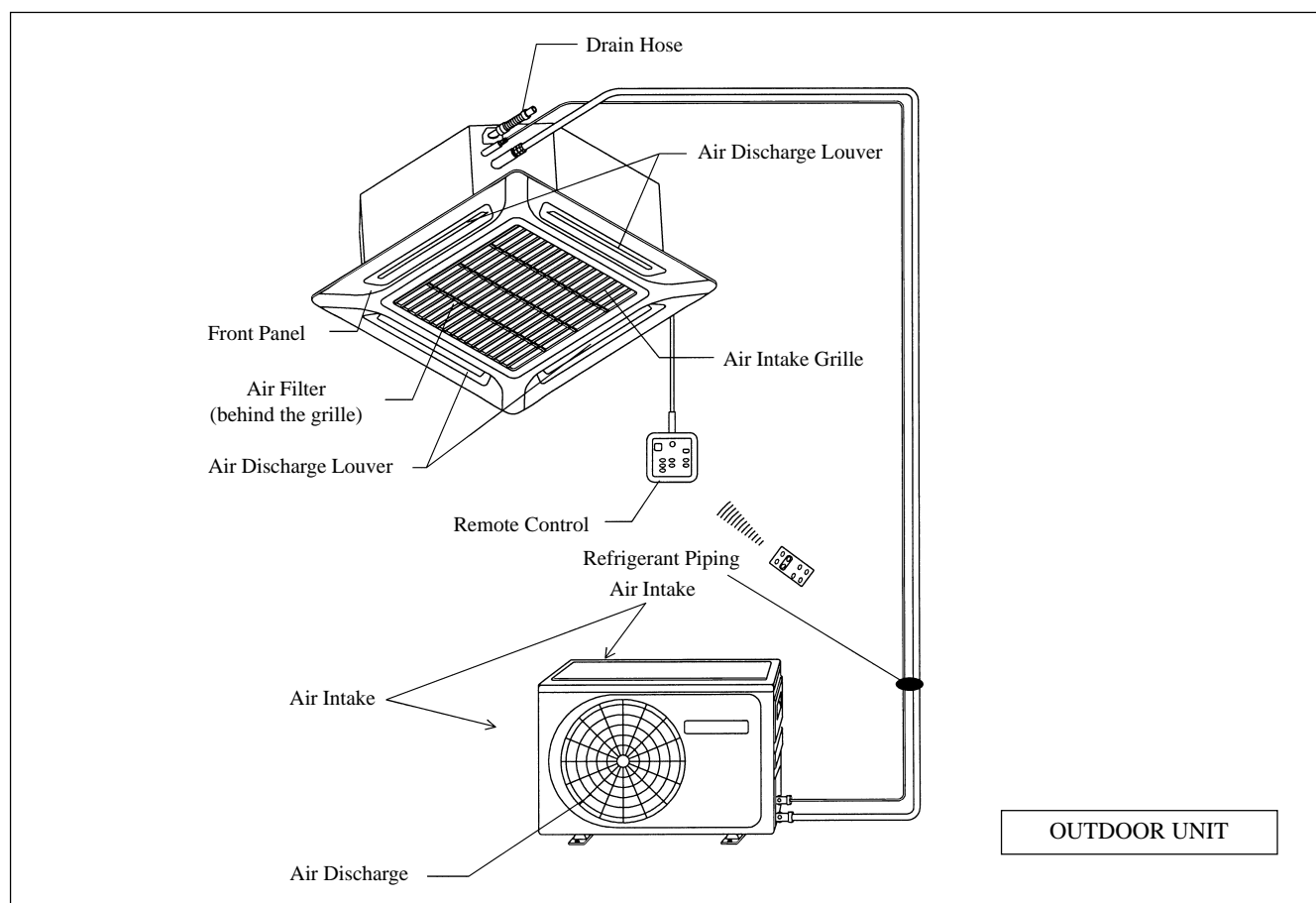



OUTLINE AND DIMENSIONS

Indoor Unit : CK20A / 25A / 30A / 40A / 50A & AR

- (With Wireless Remote Control & With Wired Remote Control)

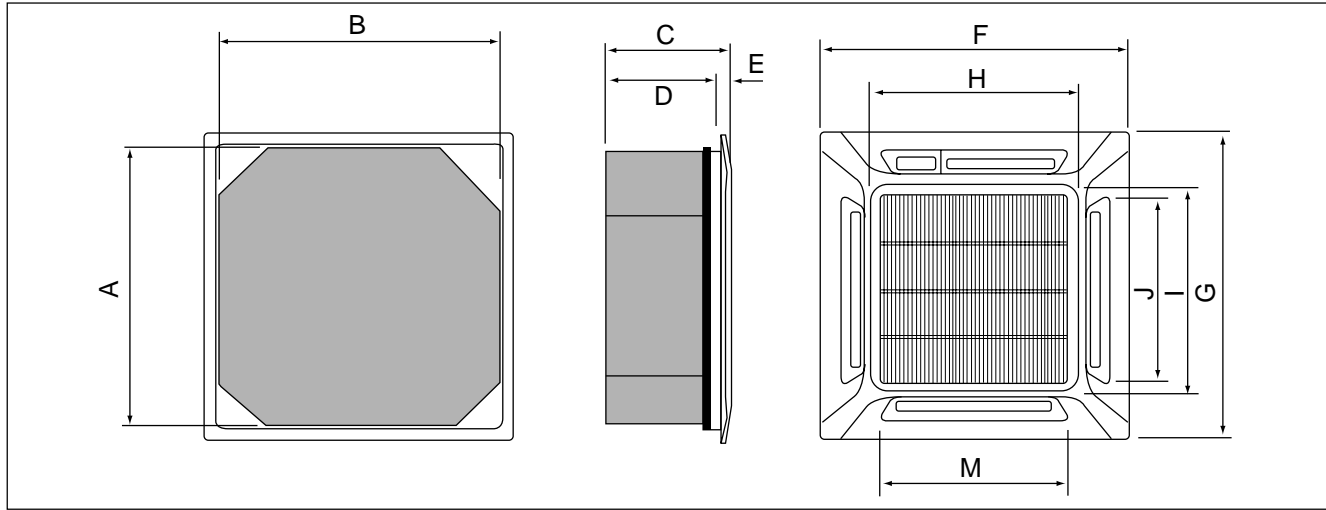

All dimensions are in mm.

MODEL	A	B	C	D	E	F	G	H	I	J	K
CK 20A/AR											
CK 25A/AR											
CK 30A/AR	820	820	363	335	28	930	930	642	622	555	555
CK 40A/AR											
CK 50A/AR											

Outdoor Unit : SL20B / 25B

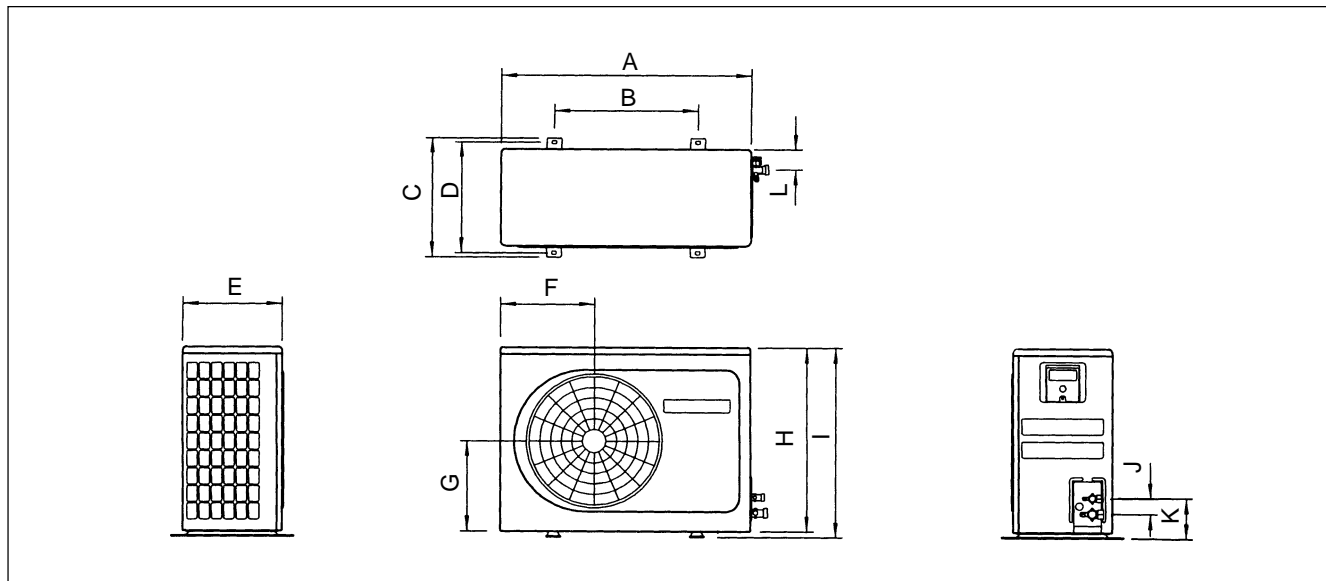

All dimensions are in mm.

MODEL	A	B	C	D	E	F	G	H	I	J	K	L
SL20B / SL20BRK	840	492	408	378	330	297	309	626	646	64	148.5	78.5
SL25B / SL25BRK												



Outdoor Unit : SL30C / 40C / 50C & CR

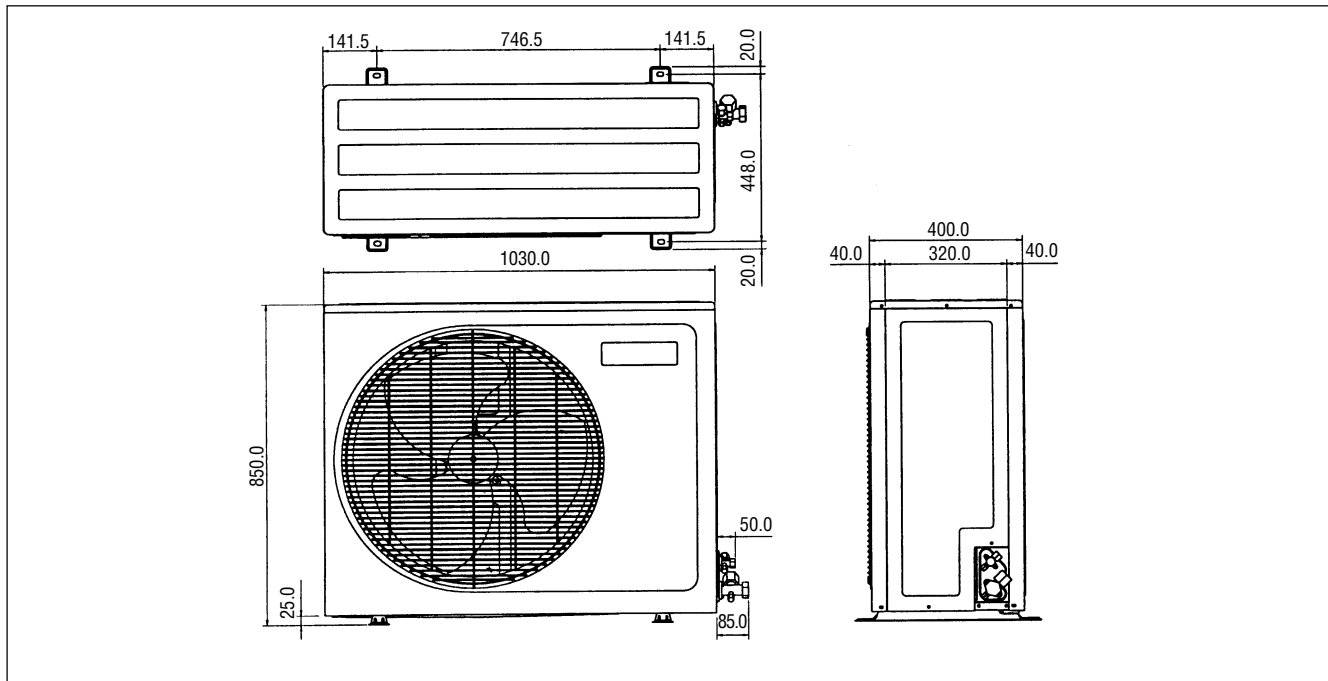

All dimensions are in mm.

Caution

Sharp edges and coil surfaces are potential locations which may cause injury hazards. Avoid from being in contact with these places.

INSTALLATION OF THE INDOOR UNIT

Preliminary Site Survey

- Electrical supply and installation is to conform to local authority's (e.g. National Electrical Board) codes and regulations.
- Voltage supply fluctuation must not exceed $\pm 10\%$ of rated voltage. Electricity supply lines must be independent of welding transformers which can cause high supply fluctuation.
- Ensure that the location is convenient for wiring, piping and drainage.
- The indoor unit must be installed in such that is free from any obstacles in path of cool air discharge and warm air return, and must allow spreading of air throughout the room (near the center of the room).
- Must be provide clearance for the indoor unit from the wall and obstacles as shown in the figure.

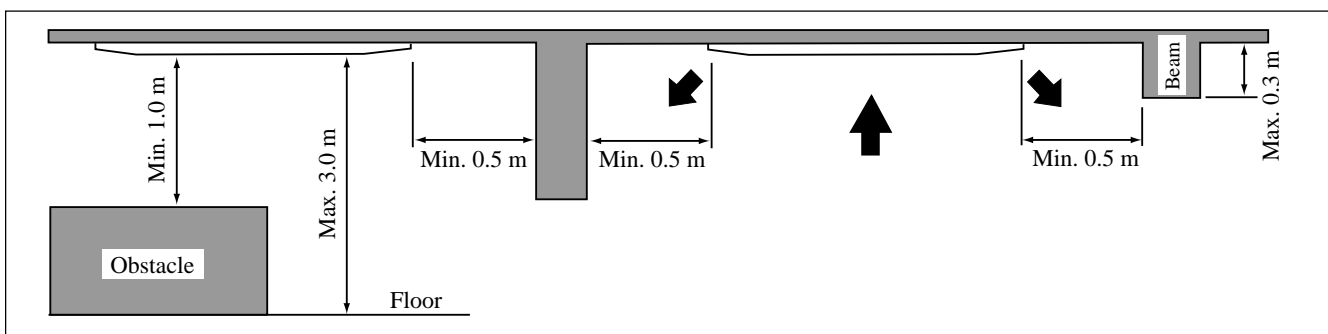

- The installation place must be strong enough to support a load 4 times the indoor unit weight to avoid amplifying noise and vibration.
- The installation place (hanging ceiling surface) must be assuring levelness and the height in the ceiling is 350mm or more.
- The indoor unit must be away from heat and steam sources (avoid installing it near an entrance).

Unit Installation

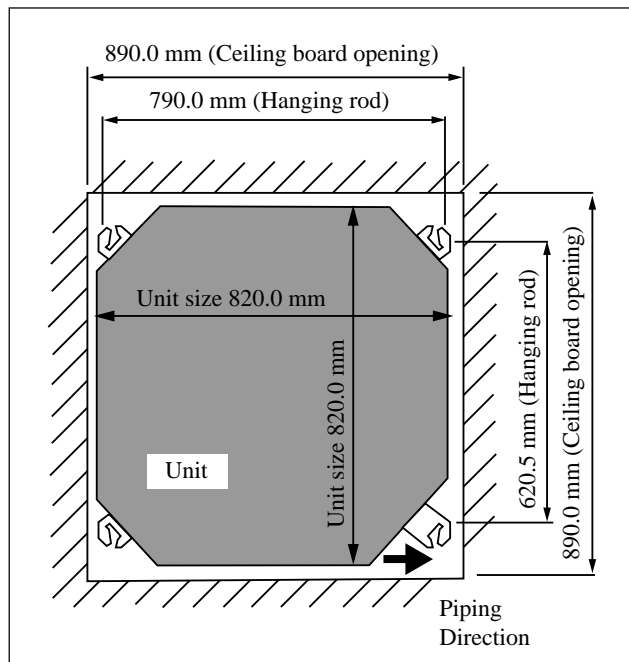

- Measure and mark the position for the hanging rod. Drill the hole for the angle nut on the ceiling and fix the hanging rod.
- The installation template is extended according to temperature and humidity. Check on dimensions in use.
- The dimensions of the installation template are the same as those of the ceiling opening dimensions.
- Before ceiling laminating work is completed, be sure to fit the installation template to the indoor unit.

NOTE

Be sure to discuss the ceiling drilling work with the installers concerned.

Unit Hanging

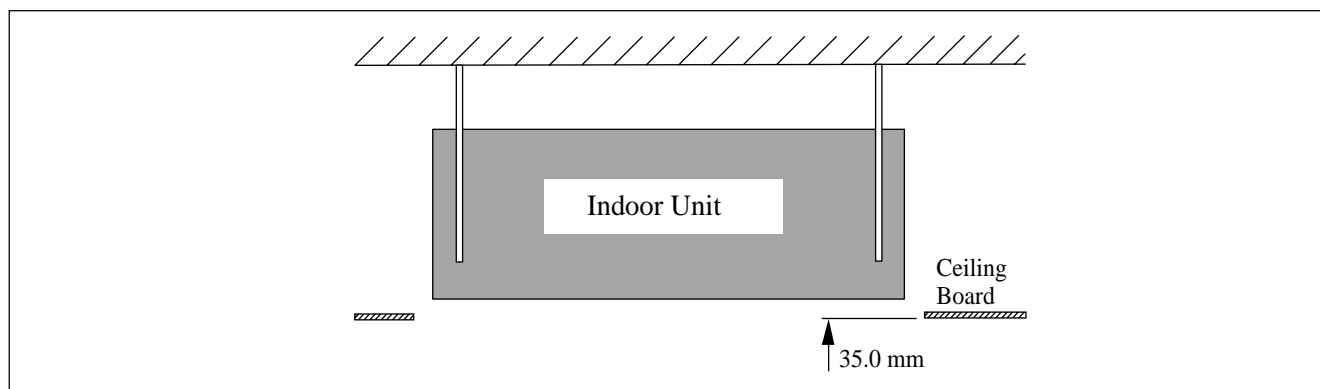

- Confirm the pitch of the hanging rod is 790mm × 620.5mm sharp.
- Hold the unit and hang it on the hanging rod with the nut and washer.
- Adjust the unit height to 35.0 mm between the indoor unit bottom surface and the ceiling surface.
- Confirm with a level gauge that the unit is installed horizontally and tighten the nut and bolt to prevent unit falling and vibration.
- Open the ceiling board along the outer edge of the paper installation template.



Drain Piping Work

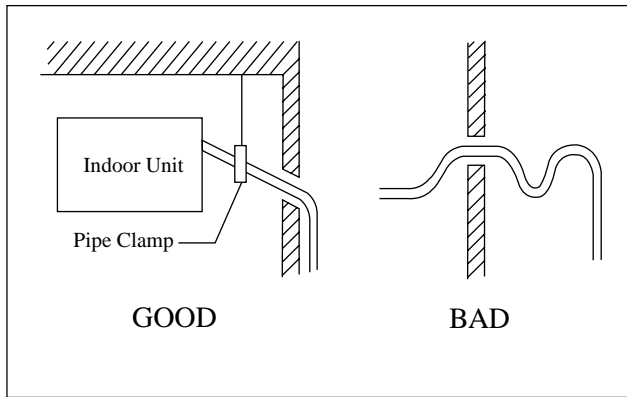

- Drain pipe must be in downward gradient for smooth drainage.
- Avoid installing the drain pipe in up and down slope to prevent reversed water flow.
- During the drain pipe connection, be careful not to exert extra force on the drain connector at indoor unit.
- The outside diameter of the drain connection at the flexible drain hose is 20mm.
- Be sure to execute heat insulation (polyethylene foam with thickness more than 8.0mm) on the drain piping to avoid the condensed water dripping inside the room.

English

Drain Test

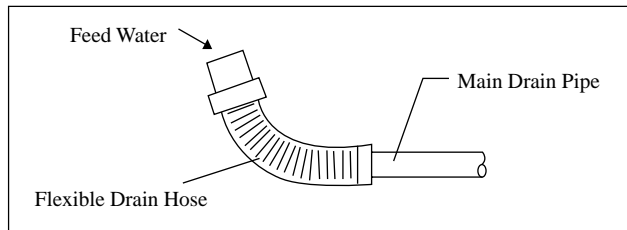

- Connect the main drain pipe to the flexible drain hose.
- Feed water from flexible drain hose to check the piping for leakage.
- When the test is completed, connect the flexible drain hose to the drain connector on the indoor unit.

NOTE

This Indoor Unit uses a drain pump for condensed water drainage. Install the unit horizontally to prevent water leakage or condensation around the air outlet.

Panel Installation

- The front panel can only be fitted in one direction, follow the piping direction. (Follow piping arrow sticker on front panel)
- Be sure to remove the installation template before installing the front panel.

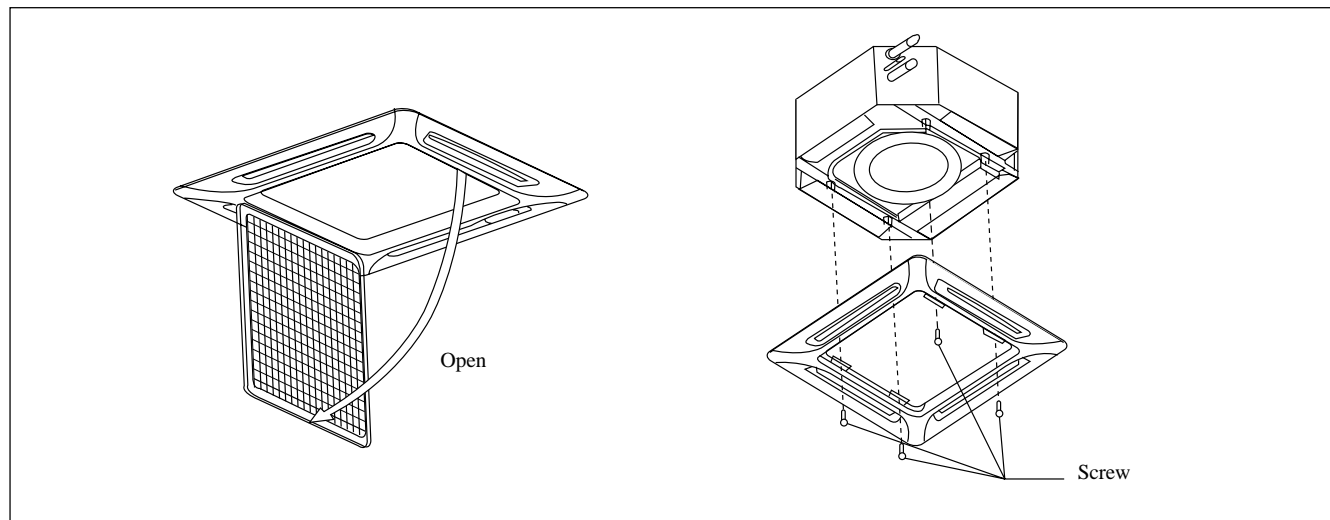

- Open the air intake grille by pulling back the catchers and removing it together with filter from panel.
- Install the front frame panel onto the indoor unit by 4 screws and tighten it completely to prevent cool air leakage.
- Connect the LED wire and air swing wire to the indoor unit.

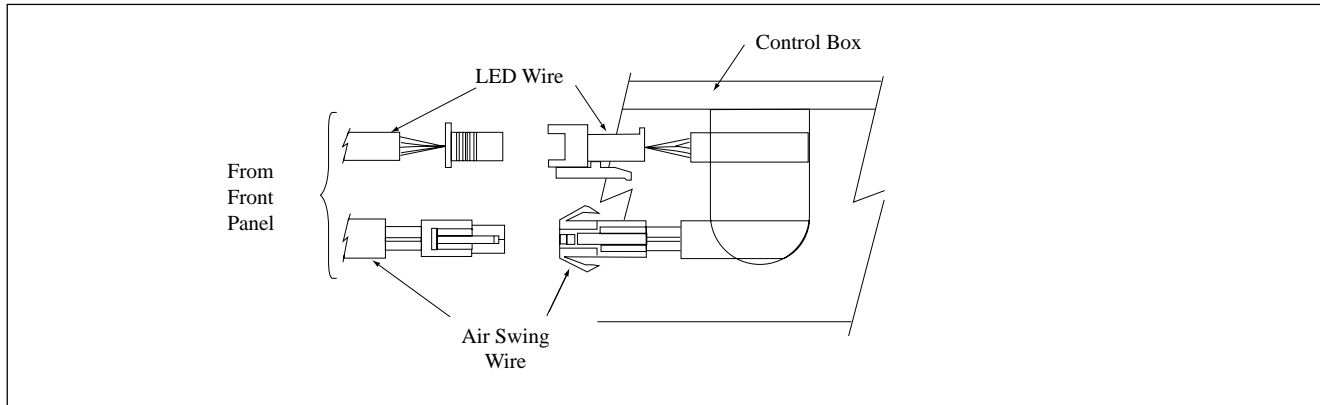

NOTE

Install the front frame panel firmly to prevent cool air leakage which will cause condensation and water dripping.

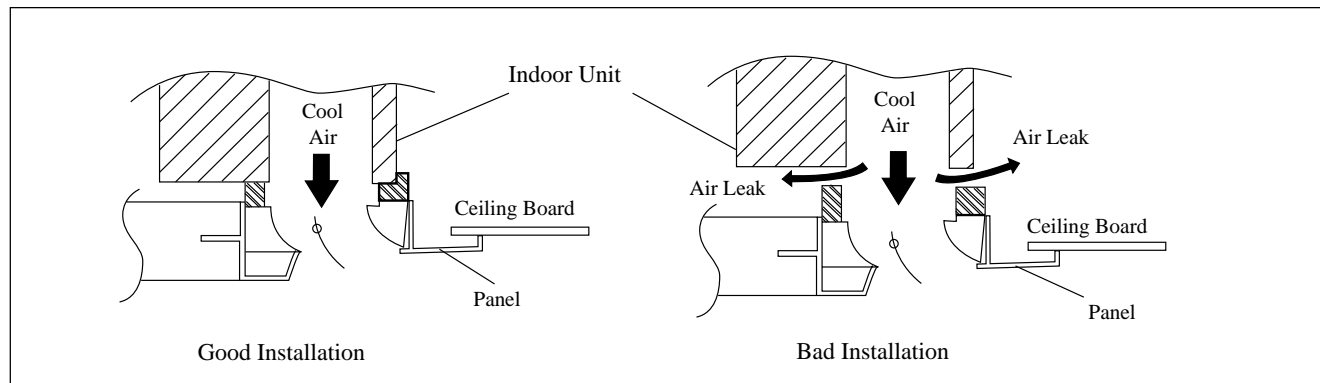

Air intake grille installation

- Before installing the air intake grille, be sure to fix the ionizer filter to the air filter.
- Install the air intake grille together with the air filter to the front panel.
- The grille can be fit in any direction, when selecting direction, the ceiling design and grille operability should be considered.
- If the unit comes with ionizer filter (optional item), make sure to fix the ionizer filter to the air filter before installing the air intake grille.
- Fix the ionizer filter to the air filter with the black side on top and white side at bottom.
- Carefully clip on the ionizer filter frame.

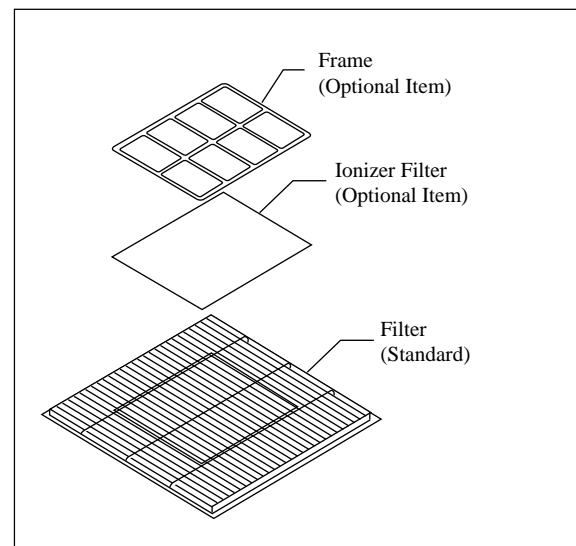



INSTALLATION OF OUTDOOR UNIT

Preliminary site survey

- A place protected from rain, direct sunlight and well-ventilated wherever practicable.
- A place capable of bearing the weight of the outdoor unit and isolating noise and vibration.
- A place where there are no obstruction of air flow into or out the unit.
- Do not put any object which may become obstacle for the air flow into or out the outdoor unit.
- The location must not be susceptible to high concentration dust, oil, salt or sulfide gas.

Outdoor unit installation

- Install the outdoor unit firmly and horizontally. Maintain a space clearance from the obstruction as shown in below for servicing and air ventilation.

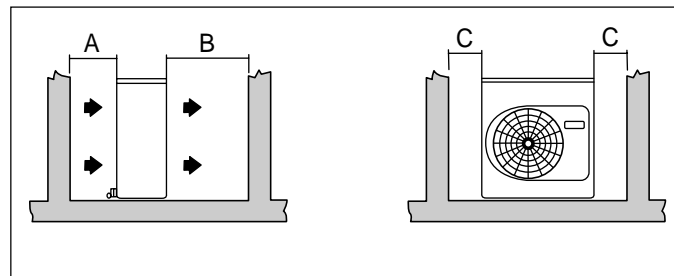
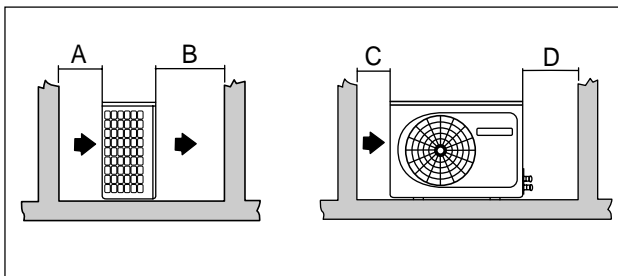

SL SERIES	A	B	C	D
MIN. DISTANCE (mm)	300	1000	300	500

MSS SERIES	A	B	C
MIN. DISTANCE (mm)	500	1000	500

REFRIGERANT PIPING WORK

Refrigerant piping is important in particular. Refrigeration cycle of the split air conditioner is realized by the perfect piping work.

Piping length and elevation

If the piping is too long, both the capacity and reliability of unit will drop. As the number of bends increase, resistance to flow of refrigerant system increases, thus lowering cooling capacity and as a result the compressor may become defective. Always choose the shortest path and follow the recommendation as tabulated below.

MODEL	INDOOR	CK20A/AR	CK25A/AR	CK30A/AR	CK40A/AR	CK50A/AR
	OUTDOOR	SL20B/BRK	SL25B/BRK	SL30C/CR	SL40C/CR	SL50C/CR
MAX. LENGTH (M)		15 m	15 m	20 m	20 m	20 m
MAX. ELEVATION (M)		8 m	8 m	10 m	10 m	10 m
MAX. NO. OF BENDS		10	10	10	10	10
LIQUID PIPE SIZE		1/4"	3/8"	3/8"	3/8"	3/8"
GAS PIPE SIZE		5/8"	5/8"	5/8"	3/4"	3/4"

Piping Connection

- Do not use contaminated or damaged copper tubing. If any piping, evaporator or condenser had been exposed or had been opened for 15 seconds or more, then vacuum and purge with field supplied refrigerant. Generally, do not remove plastic, rubber plugs and brass nuts from the valves, fittings, tubing and coils until it is ready to connect suction or liquid line into valves or fittings.
- If any brazing work is required, ensure that nitrogen gas is passed through coil and joints while the brazing work is being done. This will eliminate soot formation on the inside wall of copper tubings.
- Cut the pipe stages by stages, advancing the blade of pipe cutter slowly. Extra force and a deep cut will cause more distortion of pipe and therefore extra burr.
- Remove burrs from cut edges of pipes with a remover. This will avoid unevenness on the flare face which will cause gas leak.
- Align the center of the piping and sufficiently tighten the flare nut with fingers. Finally, tighten the flare nut with torque wrench until the wrench clicks.
- Be sure to execute heat insulation. (polyurethane form with thickness more than 15 mm)
- Except the outdoor unit which is pre-charge with refrigerant R22, the indoor unit and the refrigerant connection pipes must be purged because the air that contain moisture remaining in the refrigerant cycle may cause malfunction to the compressor.

Additional Charge

The refrigerant is pre-charge in the outdoor unit, but additional charge of refrigerant after vacuuming is necessary. Follow the recommendation as tabulated below.

Cooling Only

MODEL	INDOOR	CK20A	CK25A	CK30A	CK40A	CK50A
	OUTDOOR	SL20B	SL25B	SL30C	SL40C	SL50C
L ≤ 5 m		0.250 kg	0.100 kg	0.400 kg	-	-
L = 7 m		0.280 kg	0.176 kg	0.600 kg	0.100 kg	0.100 kg
L = 10 m		0.325 kg	0.290 kg	0.650 kg	0.250 kg	0.250 kg
L = 15 m		0.400 kg	0.480 kg	0.900 kg	0.500 kg	0.500 kg
L = 20 m		-	-	1.150 kg	0.750 kg	0.750 kg

Heat Pump

MODEL	INDOOR	CK20AR	CK25AR	CK30AR	CK40AR	CK50AR
	OUTDOOR	SL20BRK	SL25BRK	SL30CR	SL40C	SL50C
L ≤ 5 m		-	-	-	-	-
L = 7 m		0.050 kg	0.100 kg	0.100 kg	0.100 kg	0.100 kg
L = 10 m		0.075 kg	0.500 kg	0.250 kg	0.250 kg	0.250 kg
L = 15 m		0.150 kg	0.750 kg	0.500 kg	0.500 kg	0.500 kg
L = 20 m		-	-	0.750 kg	0.750 kg	0.750 kg

ELECTRICAL WIRING CONNECTION

Cooling Only

CK20A / CK25A & CK30A

MODEL	INDOOR	CK20A	CK25A
	OUTDOOR	SL20B	SL25B
VOLTAGE RANGE	220 - 240V / 1ph / 50Hz + ⊕		
POWER SUPPLY CABLE SIZE (mm ²)	2.5		2.5
NUMBER OF CONDUCTORS	3		3
INTERCONNECTION CABLE SIZE (mm ²)	2.5		2.5
NUMBER OF CONDUCTORS	3		3

IMPORTANT : These values are for information only. They should be checked and selected to comply with local and/or national codes and regulations. They are also subject to the type of installation and size of conductors.

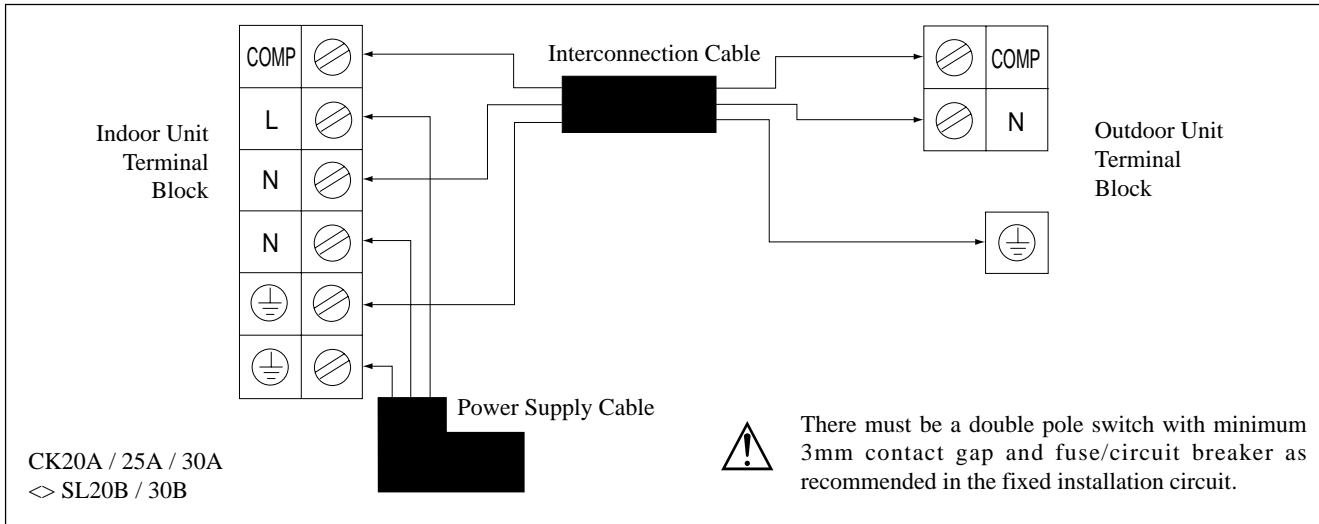

English

CK30A / CK40A & CK50A

MODEL	INDOOR OUTDOOR	CK30A SL30C	CK40A SL40C	CK50A SL50C
VOLTAGE RANGE		220 - 240V / 1ph / 50Hz +⊕	380-420V /3ph /50Hz +⊕	
POWER SUPPLY CABLE SIZE (mm ²)		4	2.5	2.5
NUMBER OF CONDUCTORS		3	5	5
INTERCONNECTION CABLE SIZE (mm ²)		1.5	1.5	1.5
NUMBER OF CONDUCTORS		4	4	4

IMPORTANT : These values are for information only. They should be checked and selected to comply with local and/or national codes and regulations. They are also subject to the type of installation and size of conductors.

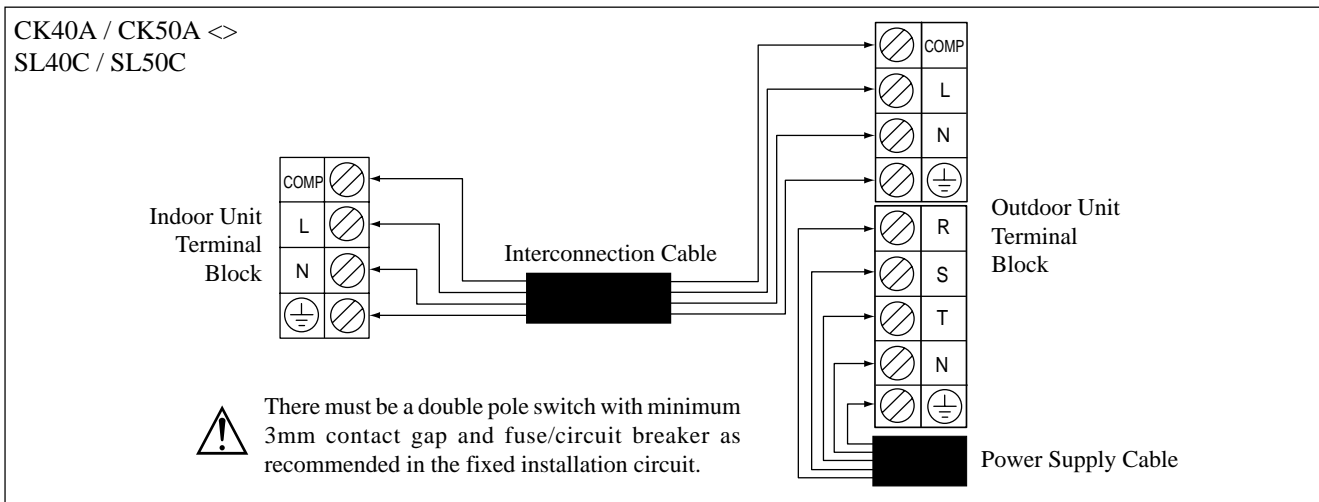
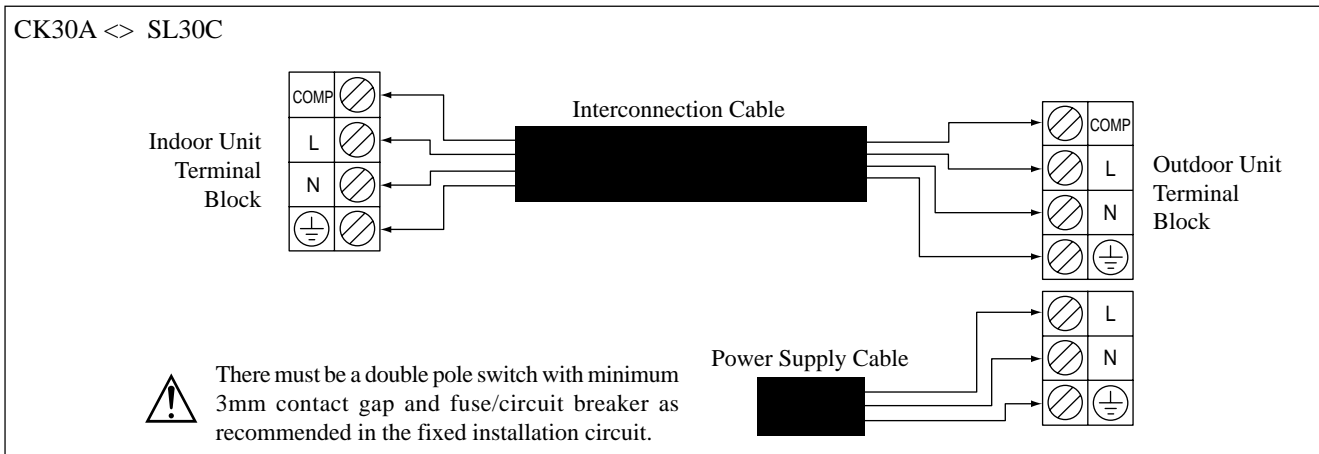

Heat Pump

CK20AR / CK25AR

MODEL	INDOOR	CK20AR	CK25AR
	OUTDOOR	SL20BRK	SL25BRK
VOLTAGE RANGE	220 - 240V / 1ph / 50Hz + ⊕		
POWER INPUT (cooling/heating), W	2225 / 1940		2937 / 2435
RATED CURRENT (cooling/heating), A	11.48 / 10.35		14.0 / 12.40
POWER SUPPLY CABLE SIZE (mm ²)	2.5		2.5
NUMBER OF CONDUCTORS	3		3
INTERCONNECTION CABLE SIZE (mm ²)	2.5		2.5
NUMBER OF CONDUCTORS	5		5

IMPORTANT : These values are for information only. They should be checked and selected to comply with local and/or national codes and regulations. They are also subject to the type of installation and size of conductors.

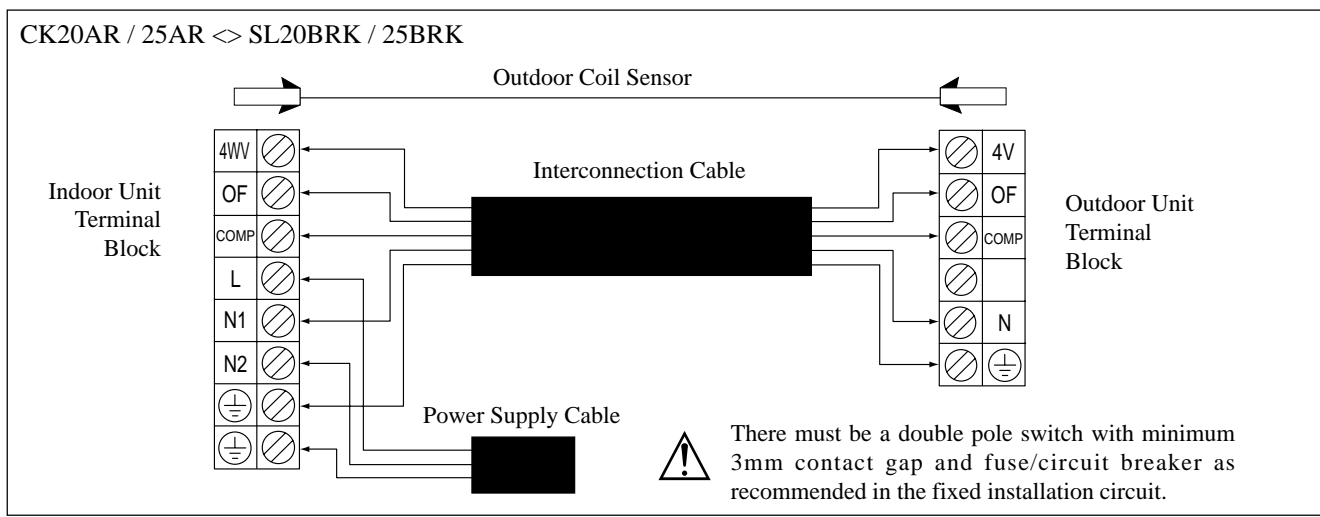

CK30AR / CK40AR & CK50AR

MODEL	INDOOR	CK30AR	CK40AR	CK50AR
	OUTDOOR	SL30CR	SL40CR	SL50CR
VOLTAGE RANGE	220-240V/1ph/50Hz + ⊕		380 - 420V / 3ph / 50Hz + ⊕	
POWER SUPPLY CABLE SIZE (mm ²)	4		2.5	2.5
NUMBER OF CONDUCTORS (1)	3		5	5
INTERCONNECTION CABLE SIZE (mm ²)	1.5		1.5	1.5
NUMBER OF CONDUCTORS (1)	7		7	7

IMPORTANT : These values are for information only. They should be checked and selected to comply with local and/or national codes and regulations. They are also subject to the type of installation and size of conductors.

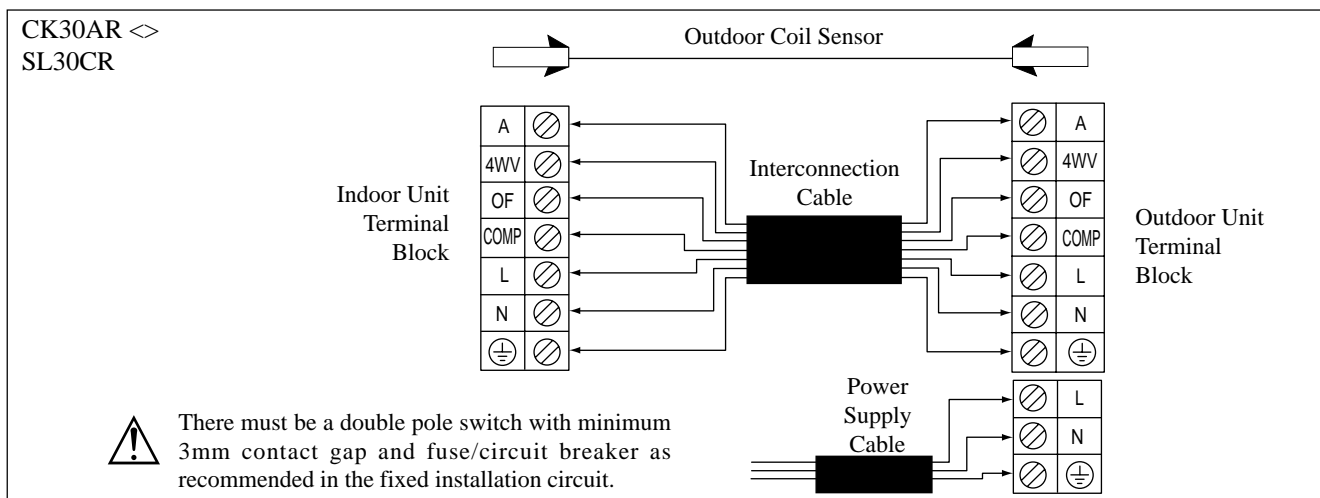



English

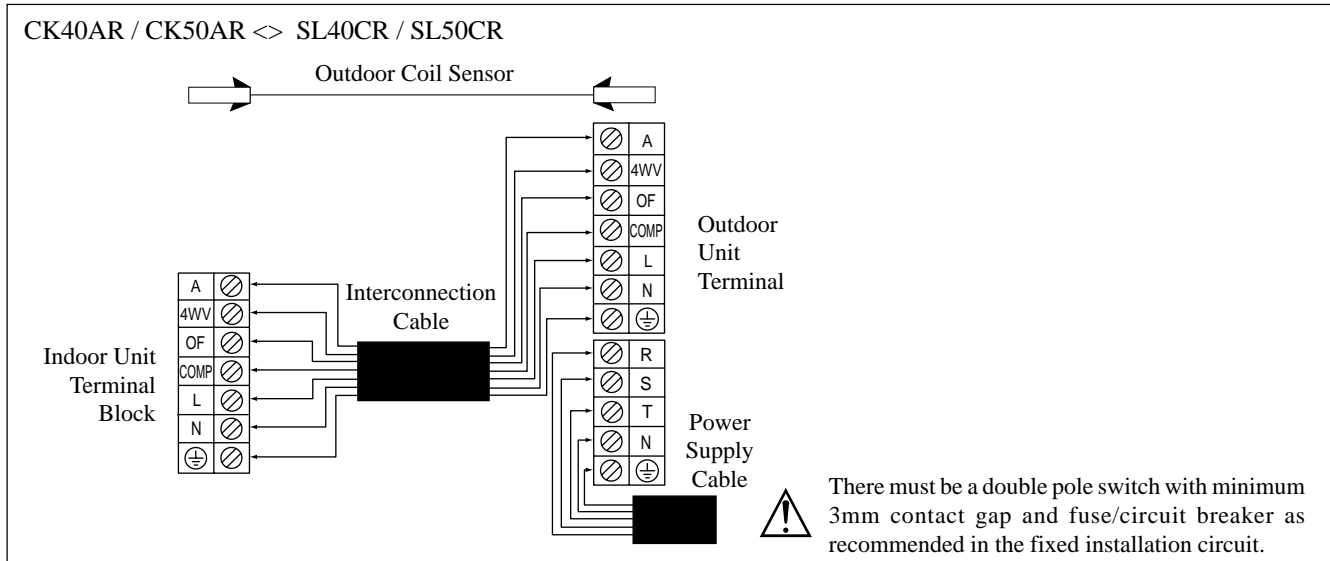

VACUUMING AND CHARGING

Vacuumping is necessary to eliminate all moisture and air from the system. The series II Outdoor Unit is provided with flare valve fittings.

Vacuumping

Before vacuumping, perform leak check for refrigeration circuit. After the system piping are properly connected, connect the flexible hoses to the correct charging nipples as shown in the diagram. Ensure that flexible hose from charging nipples are connected to the vacuum pump via standard servicing valves and pressure gauges (gauge manifold). Vacuum the air conditioner system to at least 500 microns Hg. Do not start the unit when the system is engaged in vacuumping.

Charging

Before charging, the vacuum must be held at 500 microns Hg for at least 15 minutes, then break vacuum by charging R-22 refrigerant. Operate the unit for 15 minutes and ensure the refrigerant charges is of correct by monitoring running current, gas and liquid line pressures. Suction and discharge pipe pressure should be in the region of 75 psig and 275 psig generally.

After ensuring the system is correctly charged, remove flexible hose from charging nipples and replace caps.

ACCESSORY PART

Short Duct Specification

- The indoor unit is provided with air discharge and air intake “knock-out” hole for duct connection. However the connection of the short duct for air discharge is possible on only one side.
- The use of short duct for air discharge will improve airflow distribution if there is an obstruction (such as a lighting fixture) or in a long, narrow room or an L-shaped room. It also use for air conditioning of two rooms simultaneously.

Possible Direction For Air Discharge And Air Intake

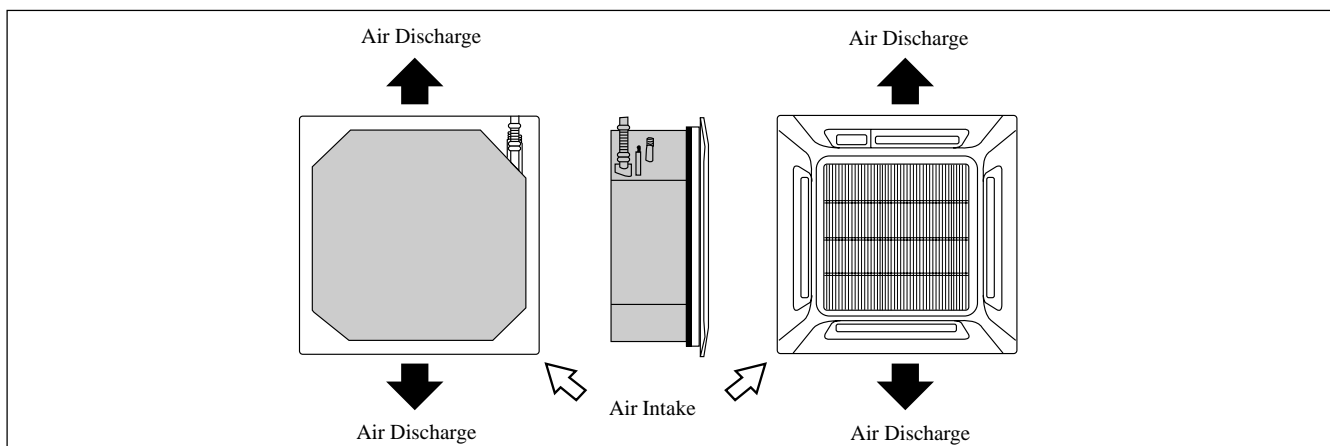

Possible Opening Dimension For Duct Connection

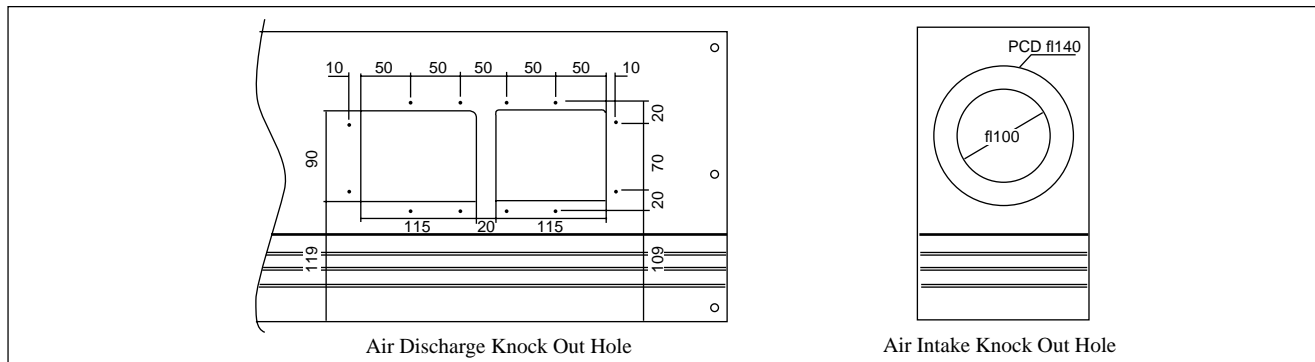

NOTE

- Avoid using the short duct on which the air discharge grille can be completely closed, to prevent evaporator freezing.
- In order to prevent condensation forming, be sure that there is sufficient thermal insulation and no leakage of cool air when installing the short duct.
- Keep the introduction of fresh air intake within 20% of total air flow. Also provide a chamber and use a booster fan.

Sealing Material

- It is possible to seal one of the four air discharge outlet. (sealing two or more air discharge outlet could cause a malfunction)
- Remove the front panel and insert the sealing material into the air discharge outlet on the indoor unit to seal the air outlet.
- The sealing material is the same length as the longer air discharge outlet. If it is desired to seal the shorter air discharge outlet, cut the sealing material to shorten it.
- Push the sealing material in about 10 mm beyond the bottom surface of the indoor unit so that it does not touch the air louver. Be sure not to push the sealing material in any farther than about 10 mm.

INDICATOR LIGHTS

Remote Control

When there is infrared remote control operating signal, the signal receiver on indoor unit will make a <beep> for signal acceptance confirmation.

Operating State And Fault Table

Wireless Remote Control

COOLING			HEAT PUMP			OPERATION / FAULTY INDICATION	ACTION
POWER	TIMER	SLEEP	POWER	TIMER	HEAT		
○	○ / ●	○ / ●	○	○ / ●	○ / ●	Power ON	-
	○			○		Room/Indoor/Outdoor (heat pump) Coil Sensor Contact Loose/Short	Call Your Dealer
○			○			Gas Leak Faulty/Compressor Overload	Call Your Dealer
○	○		○	○		Condensate Water Overflow	Call Your Dealer
					○	Outdoor Defrost (heat pump only)	

Wired Remote Control

COOLING						HEAT PUMP						OPERATION / FAULTY INDICATION	ACTION	
H I G H	M E D	L O W	C O O L	S L E E P	T I M E R	H I G H	M E D	L O W	C O O L	S L E E P	T I M E R			H I G H
		○						○					Room Sensor Contact Loose/Short	Call Your Dealer
	○						○						Indoor Coil Sensor Contact Loose/Short	Call Your Dealer
○						○							Outdoor Coil Sensor Contact Loose/Short	Call Your Dealer
				○						○			Gas Leak Faulty	Call Your Dealer
			○						○				Compressor Overload	Call Your Dealer
					○						○		Condensate Water Overflow	Call Your Dealer
												○	Outdoor Defrost (heat pump only)	Call Your Dealer

○ ON

○ / ● ON OR OFF

○ BLINKING

OVERALL CHECKING

- Ensure that :-
 - 1) The unit has been mounted solidly and rigid in position.
 - 2) Piping and connections are leak proof after charging.
 - 3) Proper wiring has been installed.
- Drainage check - pour some water into the main drain pipe from the flexible drain hose.
- Test run
 - 1) Conduct a test run after water drainage test and gas leakage test.
 - 2) Check the following items :-
 - a. Is the electric plug firmly inserted into the socket ?
 - b. Is there any abnormal sound from the unit ?
 - c. Is there any abnormal vibration on the unit itself or piping ?
 - d. Is the drainage of water smooth ?
- Confirm that :
 - 1) Condenser fan is running, with warm air blowing off the condensing unit.
 - 2) Evaporator blower is running and discharge cool air.
 - 3) The remote control incorporate a 3 minute delay in the circuit. Thus, it requires about 3 minutes before the outdoor condensing unit can start up.

English

STANDARD OPERATION CONDITIONS

Cooling

Temperature	Ts°C	Th°C
Minimum indoor temperature	16	11
Maximum indoor temperature	32	23
Minimum outdoor temperature	16	11
Maximum outdoor temperature	43	26

Heating

Temperature	Ts°C	Th°C
Minimum indoor temperature	16	-
Maximum indoor temperature	30	-
Minimum outdoor temperature	-5	-6
Maximum outdoor temperature	24	18

Ts : Dry bulb temperature.
Th : Wet bulb temperature.

⚠ Warning

- Disconnect from the main power supply before servicing the air conditioner unit.
- DO NOT pull out the power cord when the power is ON. This may cause serious electrical shocks which may result in fire hazards.

AUTO RANDOM RE-START FUNCTION

If there is a power cut when the unit is operating, it will automatically resume the same operating mode when the power is restored. (Applicable only to units with this feature)

⚠ Caution

Before turning off the power supply, set the remote controller's ON/OFF switch to the "OFF" position to prevent the nuisance tripping of the unit.

If this is not done, the unit's fans will start turning automatically when power resumes, posing a hazard to service personnel or the user.



SERVICE AND MAINTENANCE

SERVICE PARTS	MAINTENANCE PROCEDURES	PERIOD
Indoor air filter	<ol style="list-style-type: none"> 1. Remove any dust adhered on the filter by using a vacuum cleaner or wash in lukewarm water (below 40°C) with neutral cleaning detergent. 2. Rinse well and dry the filter before placing it back onto the unit. 3. Do not use gasoline, volatile substances or chemical to clean the filter. 	<p>At least once every 2 weeks.</p> <p>More frequently if necessary.</p>
Indoor unit	<ol style="list-style-type: none"> 1. Clean any dirt or dust on the grille or panel by wiping it using soft cloth soaked in lukewarm water (below 40°C) with neutral detergent solution. 2. Do not use gasoline, volatile substances or chemical to clean the indoor unit. 	<p>At least once every 2 weeks.</p> <p>More frequently if necessary.</p>



Caution

Do not operate any heating apparatus too close to the air conditioner unit. This may cause the plastic panel to melt or deform as a result of the excessive heat.

TROUBLE SHOOTING

If any malfunction of the air conditioner unit is noted, immediately switch off the power supply to the unit. Check the following fault conditions and causes for some simple trouble shooting tips.

FAULT	CAUSES / ACTION
1. The compressor does not start operate after 3 minutes from starting the air conditioner unit.	- Protection against frequent starting. Wait for 3 to 4 minutes for the compressor to start operating.
2. The air conditioner unit does not operate.	<ul style="list-style-type: none"> - Power failure, or the fuse need to be replaced. - The power plug is disconnected. - It is possible that your delay timer has been set incorrectly. - If the fault persist after all these verifications, please contact the air conditioner unit installer.
3. The air flow is too low.	<ul style="list-style-type: none"> - The air filter is dirty. - The doors or windows are open. - The air suction and discharge are clogged. - The regulated temperature is not high enough.
4. Discharge air flow has bad odor.	- Odors may be caused by cigarettes, smoke particles, perfume etc. which might have adhered onto the coil.
5. Condensation on the front air grille of the indoor unit.	<ul style="list-style-type: none"> - This is caused by air humidity after an extended long period of operation. - The set temperature is too low, increase the temperature setting and operate the unit at high fan speed.
6. Water flowing out from the air conditioner unit.	- Switch off unit and call dealer.
7. Hissing air flow sound from the air conditioner unit during operation.	- Refrigerant fluid flowing into the evaporator coil.

If the fault persists, please call your local dealer / serviceman.

- In the event that there is any conflict in the interpretation of this manual and any translation of the same in any language, the English version of this manual shall prevail.
- The manufacturer reserves the right to revise any of the specification and design contain herein at any time without prior notification.
- En cas de désaccord sur l'interprétation de ce manuel ou une de ses traductions, la version anglaise fera autorité.
- Le fabricant se réserve le droit de modifier à tout moment et sans préavis la conception et les caractéristiques techniques des appareils présentés dans ce manuel.
- Im Falle einer widersprüchlichen Auslegung der vorliegenden Anleitung bzw. einer ihrer Übersetzungen gilt die Ausführung in Englisch.
- Änderungen von Design und technischen Merkmalen der in dieser Anleitung beschriebenen Geräte bleiben dem Hersteller jederzeit vorbehalten.
- Nel caso ci fossero conflitti nell'interpretazione di questo manuale o delle sue stesse traduzioni in altre lingue, la versione in lingua inglese prevale.
- Il fabbricante mantiene il diritto di cambiare qualsiasi specificazione e disegno contenuti qui senza precedente notifica.
- En caso de conflicto en la interpretación de este manual, y en su traducción a cualquier idioma, prevalecerá la versión inglesa.
- El fabricante se reserva el derecho a modificar cualquiera de las especificaciones y diseños contenidos en el presente manual en cualquier momento y sin notificación previa.
- В случае противоречия перевода данного руководства с другими переводами одного и того же текста, английский вариант рассматривается как приоритетный.
- Завод-изготовитель оставляет за собой право изменять характеристики и конструкцию в любое время без предварительного уведомления.

OYL MANUFACTURING COMPANY SDN. BHD.

JALAN PENGAPIT 15/19, P.O. BOX 7072, 40702 SHAH ALAM, SELANGOR DARUL EHSAN, MALAYSIA.