

Start Here

▼ Installing your Microtek ScanMaker 9800XL Plus

Step 1

Unpack Contents

Unpack your scanner package and check for major components.

1. ScanMaker 9800XL Plus
2. USB cable
3. Power cord
4. Software CDs/DVDs
5. TMA 1600-III (Optional) — Film Templates, Black Plates, and Film Alignment Ruler

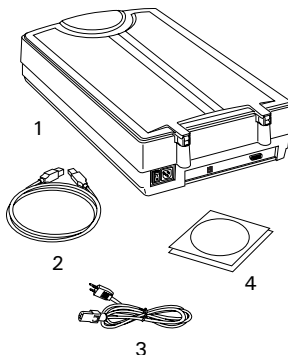

5. Optional package items depend on the scanner configuration that you purchased.

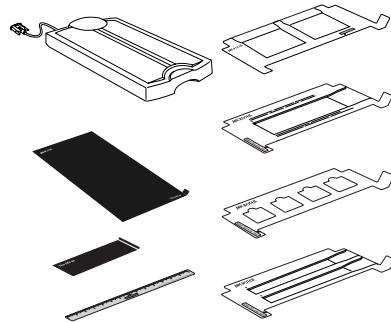

Step 2

Install Software

Important: Do not remove the yellow stickers from your scanner until you are told to do so.

You must install software before connecting your scanner.

Always close any open programs, and turn off Anti-virus utilities before installing software.

PC:

- A. Place the **Adobe DVD** into a drive, and install the software. Skip this step if you have a newer version of Photoshop Elements already installed on your computer.
- B. Place the **Microtek Software CD/DVD** into a drive, and follow the on-screen instructions to install the scanner driver and software.
- C. Restart your computer at the end of all software installation.

NOTE: If the Microtek Software Installer screen does not come up automatically, double-click the following in succession: "My Computer"; the CD-ROM (or DVD-ROM) icon; then cdsetup.exe to start the installer program.

MAC:

- A. Place the **Adobe DVD** into a drive, and install the software. Skip this step if you have a newer version of Photoshop Elements already installed on your computer.
- B. Place the **Microtek Software CD/DVD (ScanPotter)** into a drive, and double-click the **ScanPotter** installer icon to install ScanPotter.
- C. Install the remaining software components, then restart your computer at the end of all software installation.

NOTE: After rebooting your Macintosh, the Microtek software will attempt to locate your scanner on the system. Since this is your first install and you have not yet connected the scanner, simply ignore the message that appears and proceed to the next step.

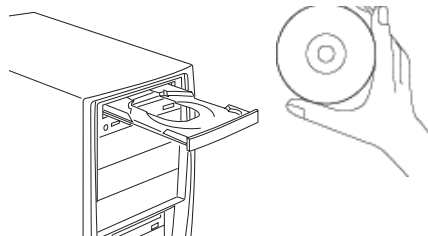

Step 3 Unlock Scanner

- Remove the yellow "Step 3" sticker from your scanner.
- With the scanner power off, tilt the front right corner of the scanner to see the locking screw at the bottom.
- Using a screwdriver, push and turn the locking screw counterclockwise to the unlock position. When successfully unlocked, the screw will push out a little, protruding slightly from the bottom of the scanner.

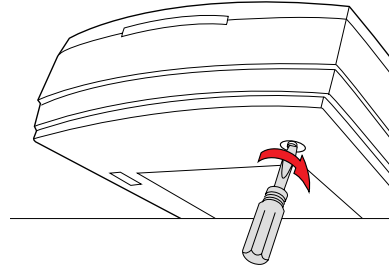

NOTE: To lock the scanner (for shipping and other reasons), refer to the ScanMaker 9800XL Plus User Guide.

Step 4 Connect Scanner

To the power adapter

- Remove the yellow "Step 4" sticker from your scanner.
- Connect the power cord to the back of the scanner.
- Plug the power cord into a power source.

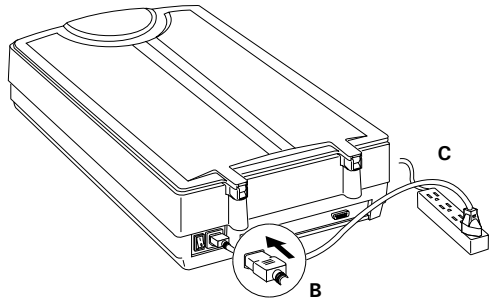

To the Hi-Speed USB cable

- Connect one end of the cable to your computer.
- Connect the other end of the cable to the scanner.
- Press the power switch at the back of your scanner, and wait for the indicator light on the front panel to stop blinking and stay on steady.

The system will detect your scanner automatically.

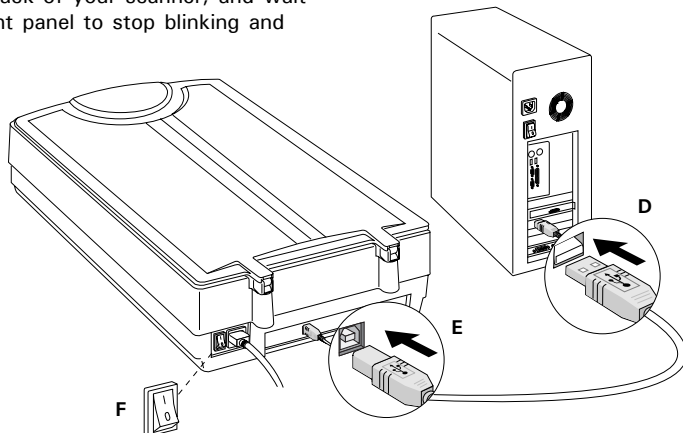

Using the TMA 1600-III

NOTE: If you purchased a standard ScanMaker 9800XL Plus without the TMA 1600-III, see only the section on positioning reflective materials without the TMA 1600-III, on page 5.

I. Installing the TMA 1600-III

1. Make sure that the scanner power is turned off.
2. Remove the scanner lid, then attach the TMA 1600-III by sliding the posts at the rear of the TMA 1600-III into the holes.

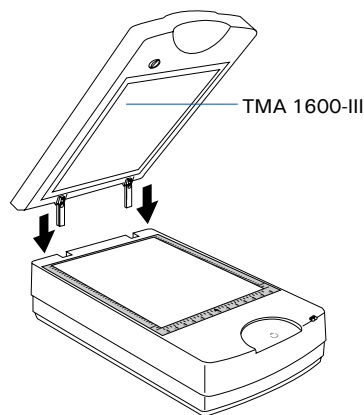
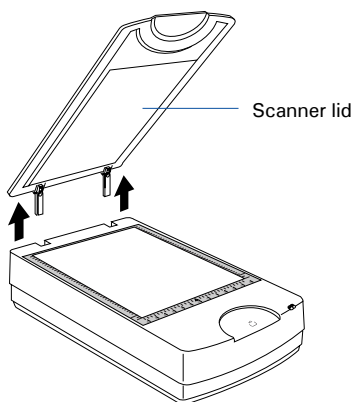

3. Plug the connector of the TMA 1600-III into the scanner's 15-pin accessory port.

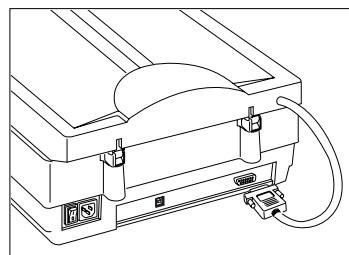

II. Unlocking the TMA 1600-III

1. Remove the yellow "Step 3" sticker from the TMA 1600-III.
2. Look for the locking knob at the base of the TMA 1600-III.
3. Turn the locking knob counterclockwise to the unlock position "🔓".

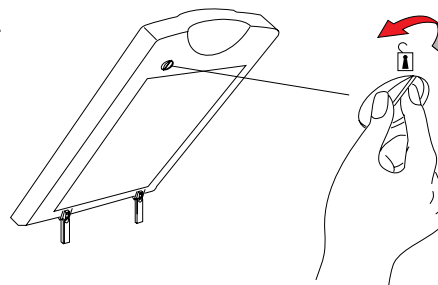

NOTE: If you need to transport your TMA 1600-III, you will have to lock it back. For more details, please see the ScanMaker 9800XL Plus User Guide.

Positioning the Scan Material

A. Positioning Transparencies

- To scan standard-size transparent film such as 35mm slides, 35mm filmstrips, 4"x5" film, or 120 film: Use the individual film templates included with the TMA 1600-III package. Make sure the templates are oriented correctly on the scanner glass surface, with the Microtek logo on the templates facing up. Keep the calibration strip on the glass surface clear and free of obstruction at all times.

Important:
When using the templates, make sure you use the correct side up. The correct side up is the side showing the "Microtek" logo facing up.

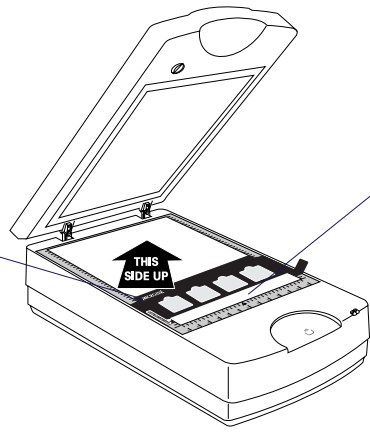

Using the 35mm Slide Template

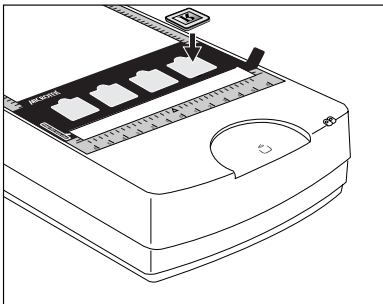

Using the 35mm Filmstrip Template

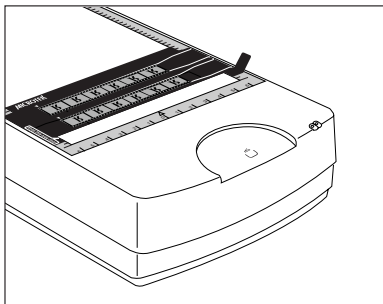

Using the 120 Film Template

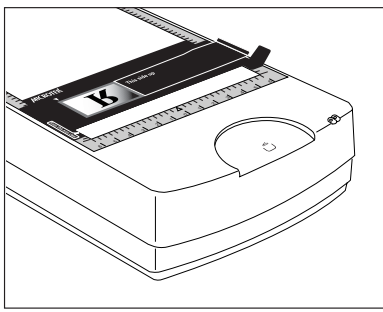

Using the 4" x 5" Film Template

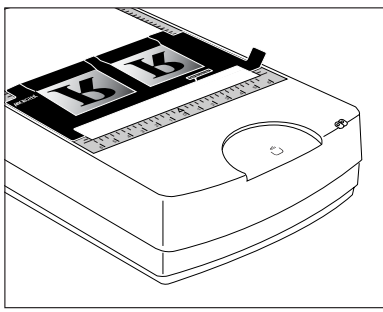

- To scan non-standard-size transparent film, use the Film Alignment Ruler included with the TMA 1600-III package. Place the Film Alignment Ruler on the scanner glass surface. Then place the film to be scanned face down on the scanner glass surface, centering the film along the Film Alignment Ruler. Make sure you keep the calibration strip on the glass surface clear and free of obstruction at all times.

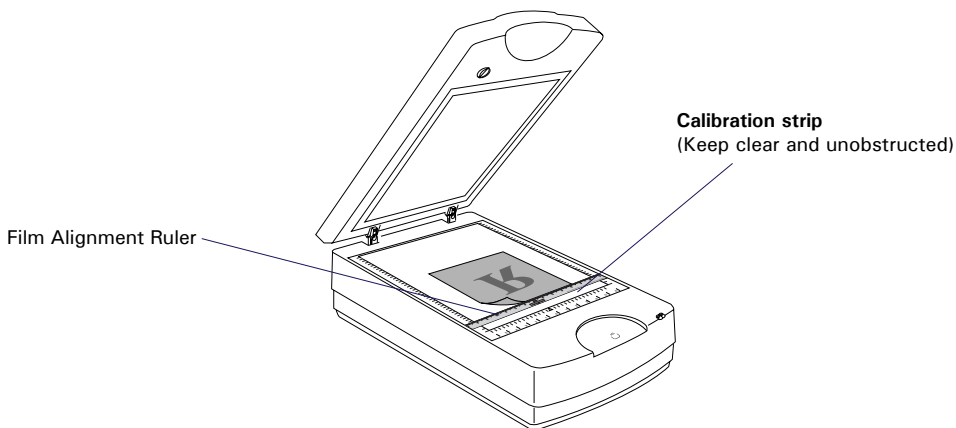

B. Positioning Reflectives

To scan reflective originals such as photos, you can use the ScanMaker 9800XL Plus with or without the TMA 1600-III.

- If you purchased your ScanMaker 9800XL Plus with the TMA, you will need to use the Black Plate included with your TMA 1600-III package to shield unwanted light.
- If you purchased your ScanMaker 9800XL Plus without the TMA, simply lift the scanner lid, and place the reflective original to be scanned on the glass surface. Center the photo along the U-shaped ruler of the scanner.

With TMA 1600-III

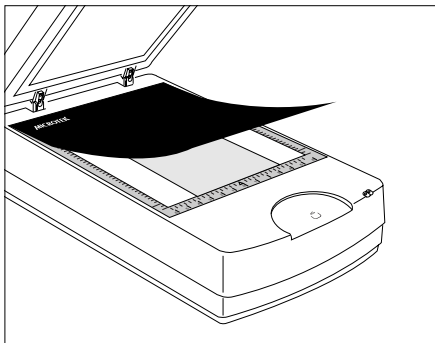

Without TMA 1600-III

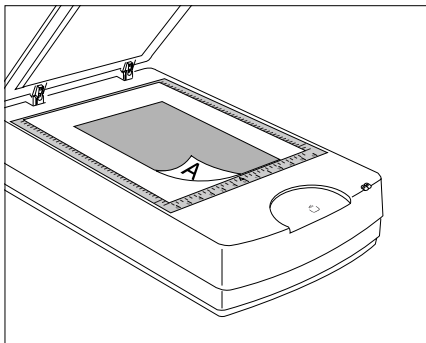

Basic Scanning for PC Users

Scanning Photos

1. Position the photo face down on the scanner glass surface, towards the front of the scanner. Center the top along the U-shaped ruler on the scanner.
2. Launch **ScanWizard Pro**.
If prompted to set up Color Matching, click OK for now to accept the settings. You can always change the settings at a later time. For more details, see the ScanMaker 9800XL Plus User Guide.
3. In the Preview window of ScanWizard Pro, choose **Reflective** from the Scan Material menu.
4. Click the **Overview** button in the Preview window to see a preliminary scan of the image.
5. Select the **Scan Frame** tool, and choose the area to be scanned by sizing the marquee around the targeted area.
6. Specify your scanning requirements in the Settings window. Choose the desired image type and resolution, and adjust the scan frame settings if necessary.
7. Adjust image quality if necessary, using the Advanced Image Correction tools.
8. Click the **Scan** (or "Batch") button in the Preview window or on the scanner unit to start scanning.

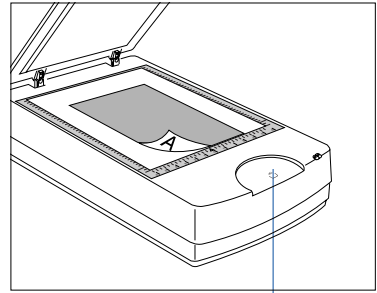

Smart-Touch button (Scan)

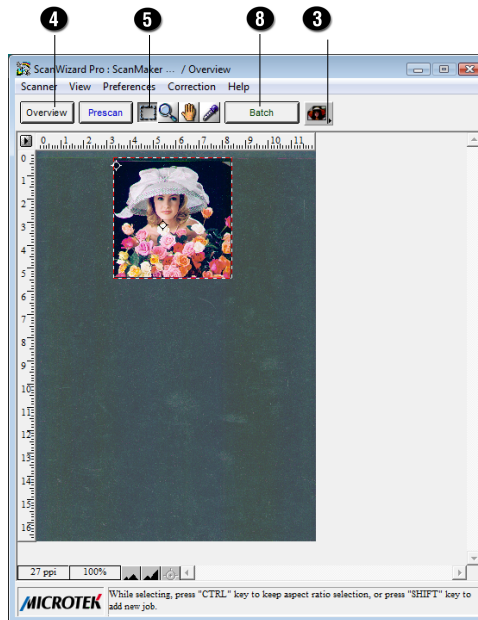
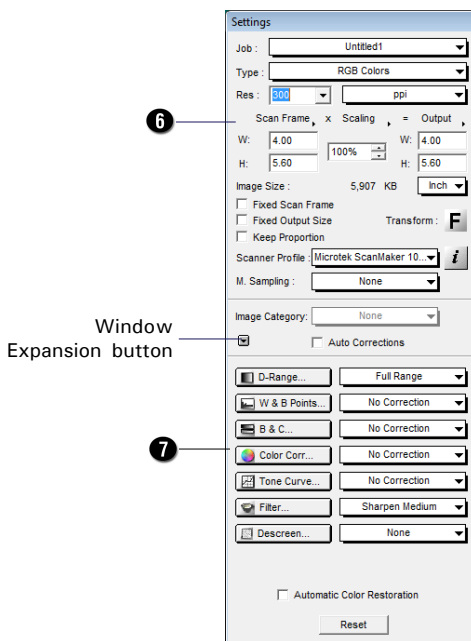

Preview window

Scanning Positive or Negative Film

1. Select the film you wish to scan, then follow the procedures for positioning transparent films detailed in the "Positioning Transparencies" section of this Guide.
2. Launch **ScanWizard Pro**.
3. If scanning positive film such as 35mm slides:
 - a) Go to the Preview window of ScanWizard Pro and from the Scan Material menu, choose *Positive / Positive Film*.
 - b) Follow steps 4 to 7 of the procedures detailed in "Scanning Photos".

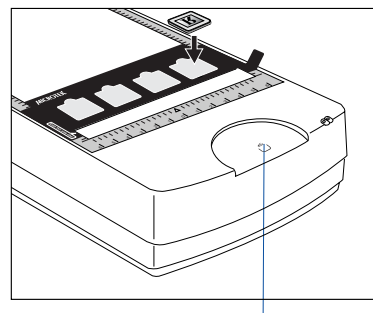

Smart-Touch button (Scan)

If scanning negatives:

- a) Go to the Preview window of ScanWizard Pro and from the Scan Material menu, choose *Negative / Negative Film*. The Negative Scan Settings window appears.
 - b) Go to the Negative Scan Settings window, choose the film brand, film type, and ISO settings that match the film you use. For more details, refer to a PDF document called "ScanWizard Pro Reference Manual" in your Microtek software CD/DVD and see the *Addendum to ScanWizard Pro* section.
 - c) Follow steps 4 to 7 of the procedures detailed in "Scanning Photos".
4. Click the **Scan** (or "Batch") button in the Preview window or on the scanner unit to start scanning.

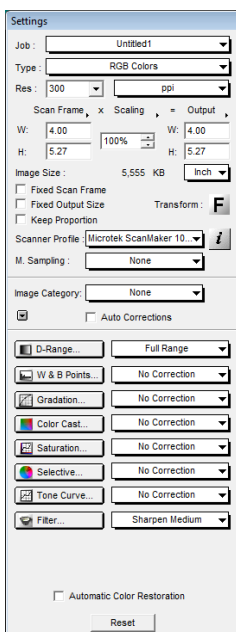

Settings window

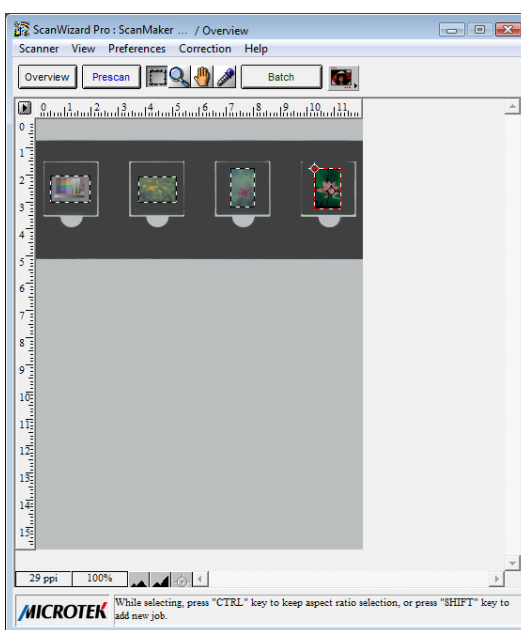

Preview window

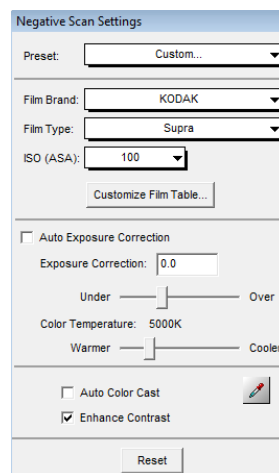

Negative Scan Settings window

Basic Scanning for Mac Users

1. Place the scan material.
 - To scan a photo, place the photo on the upper glass bed, as detailed in the “Positioning Reflectives” section in this guide.
 - To scan film, use the film holder, as detailed in the “Positioning Transparencies” section in this guide.
2. Launch **ScanPotter** as a stand-alone by clicking on the program icon, or by selecting it from the application folder in your Mac OS X system.
3. In the Scan Source options menu, depending on the scan material you are using, choose **either Reflective** for photos, **Negative Film** for negatives, or **Positive Film** for transparencies and slides.
4. Specify your scanning requirements in the Scanner Settings column.
 - a) Select the appropriate image type (e.g., RGB Color) in the Color Type as your image output type.
 - Select **Color** to scan the image in color.
 - Select **Grayscale** to scan the image in grayscale.
 - Select **Black & White** to scan the image in black-and-white.
 - b) Select a desired resolution in the Resolution for your image output resolution.
 - c) Select **Automatic Detection** or a desired dimension in the Scan Frame as your preview image size.
5. Click the **Preview** button to perform a preliminary scan of the image in the Preview window.
6. If necessary, resize the scan frame (floating dotted rectangle) around the image by dragging on the square spots on the edge or on the corner of the scan frame to determine the final size of the actual scan.
7. If necessary, specify file settings for your output image files, using the options offered in the File Saving Settings column.
8. If necessary, click the **Image Settings** button to switch to a window in which you can select a preset image effect to the image directly or adjust image quality manually by using the additional image correction tools.
9. Click the **Scan** button to start scanning.

NOTE: For details on scanning photos and film, see the *ScanMaker 9800XL Plus User Guide* in the Microtek Software CD/DVD.

Basic Scanning for Mac Users (cont.)

Scan frame (enclosed by dotted lines)

Click the **Scan Settings** button to switch back to the default control panel of ScanPotter

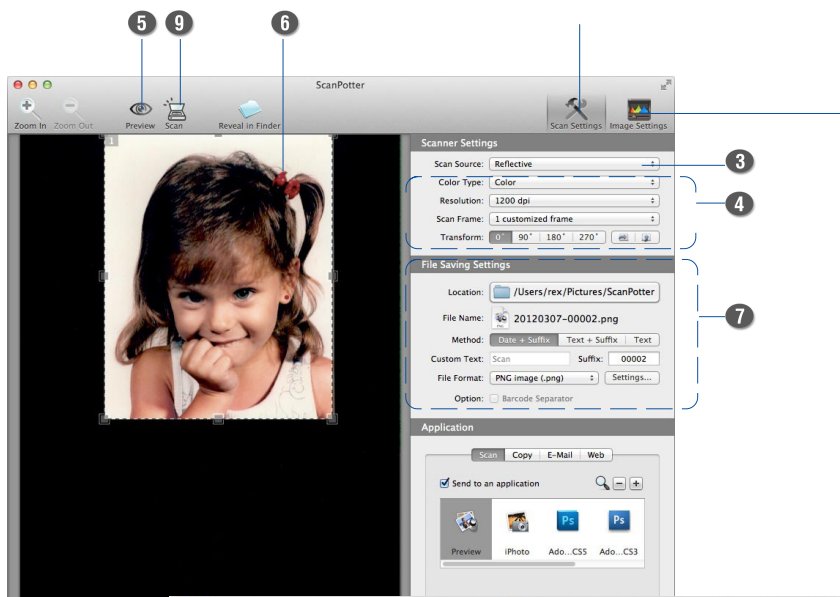

Click the **Image Settings** button to switch to a window where contains a composite display of nine-image-effects (Filter column) and additional image correction tools (Additional Adjustment column) for your scanned image.

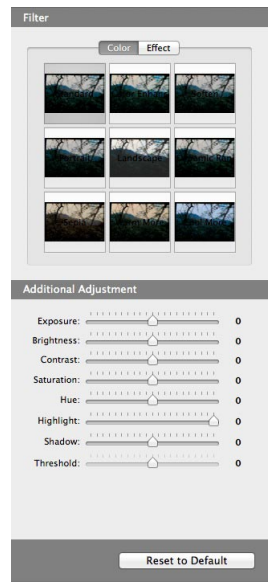

Preview window when scanning photos

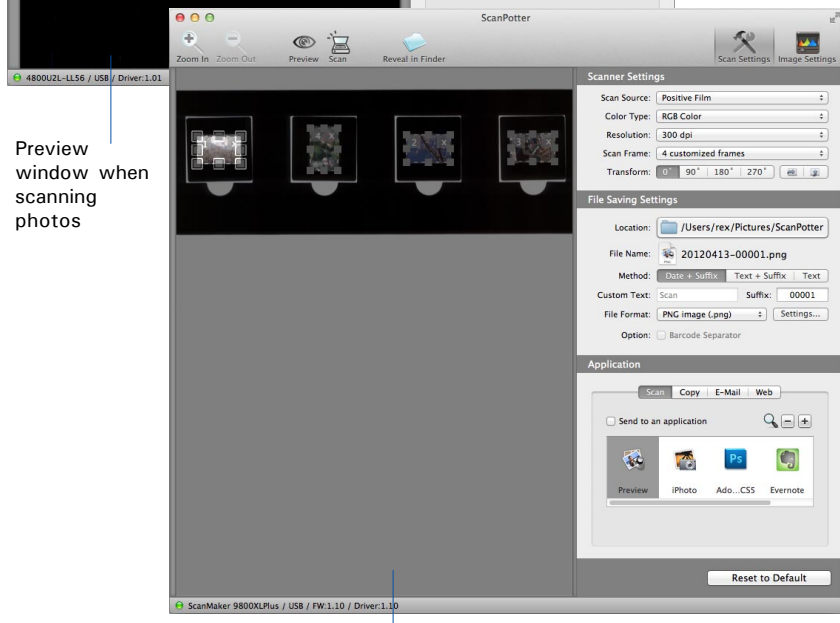

Preview window when scanning slides

Problems?

The green LED on the front panel indicates the status of the scanner. The amber LED beside it stands for power and should always stay on steady when the scanner is on.



On - Ready to scan



Flashing - Scanning



Off - Call Tech Support

First, make sure that you have followed installation steps 1 through 4. If your problem is listed here, try the suggested solution.

1. No light comes on when the scanner is turned on.

Make sure your scanner is connected to your computer and plugged into a power source.

2. Add/Remove Hardware Wizard appears on your screen.

Click the "Cancel" button and close the Control Panel. Disconnect the USB cable from the back of your computer, and refer to the installation instructions in this guide.

3. When trying to scan, an error message appears on your screen that reads, "Can't Find Scanners".

Make sure your scanner is unlocked (see Step 3).

Make sure your scanner is connected to your computer and plugged into a power source (see Step 4).

Uninstall and reinstall the ScanWizard Pro or ScanPotter software.

4. After clicking scan, a blank screen appears.

Make sure your scanner is unlocked (see Step 3).

Uninstall and reinstall the ScanWizard Pro or ScanPotter software.

5. Having trouble scanning negatives or slides?

Make sure that you have properly inserted the templates, as indicated in the "Positioning Transparencies" section of this guide. The templates should be placed correctly on the scanner glass surface, with the "Microtek logo" on the templates facing up.

From the Preview window of **ScanWizard Pro**, choose **Positive** or **Negative** from the Scan Material menu.

From the **ScanPotter**, go to the **Scanner Settings** column, then click the **Scan Source** drop-down menu to select either the **Positive Film** or **Negative Film** option.

Make sure that the calibration strip is unobstructed. For location of the calibration strip, see the "Positioning Transparencies" section.

Uninstall and reinstall the ScanWizard Pro or ScanPotter software.

Do You Need Assistance?

Manuals

If you have additional questions and need further instruction or information, we provide electronic manuals for:

1. Using your ScanMaker 9800XL Plus User Guide
2. Using the ScanWizard Pro and ScanPotter scanning software
3. Using the bundled third-party software

To access the electronic manuals: Insert the scanner's software CD/DVD into your computer's CD-ROM/DVD-ROM drive. Next, locate and click the "Manuals" option when the software installer window appears on your screen. Finally, select and click the title of the manual you wish to view.

Missing Items

If your package is missing items, please call Microtek Customer Service Department.

Drivers & Software Upgrades

After you finish the installation of software, if you found that the installed drivers and software cannot run your product or your computer system properly later, please go to the Microtek **Download Service** site at ww7.microtek.com.tw/service.php to download and install any updates you may require.

For additional information about Microtek products, please visit our website at www.microtek.com.