



38GL...G / 38GLS...G

38YY...G / 38YYS...G



CE

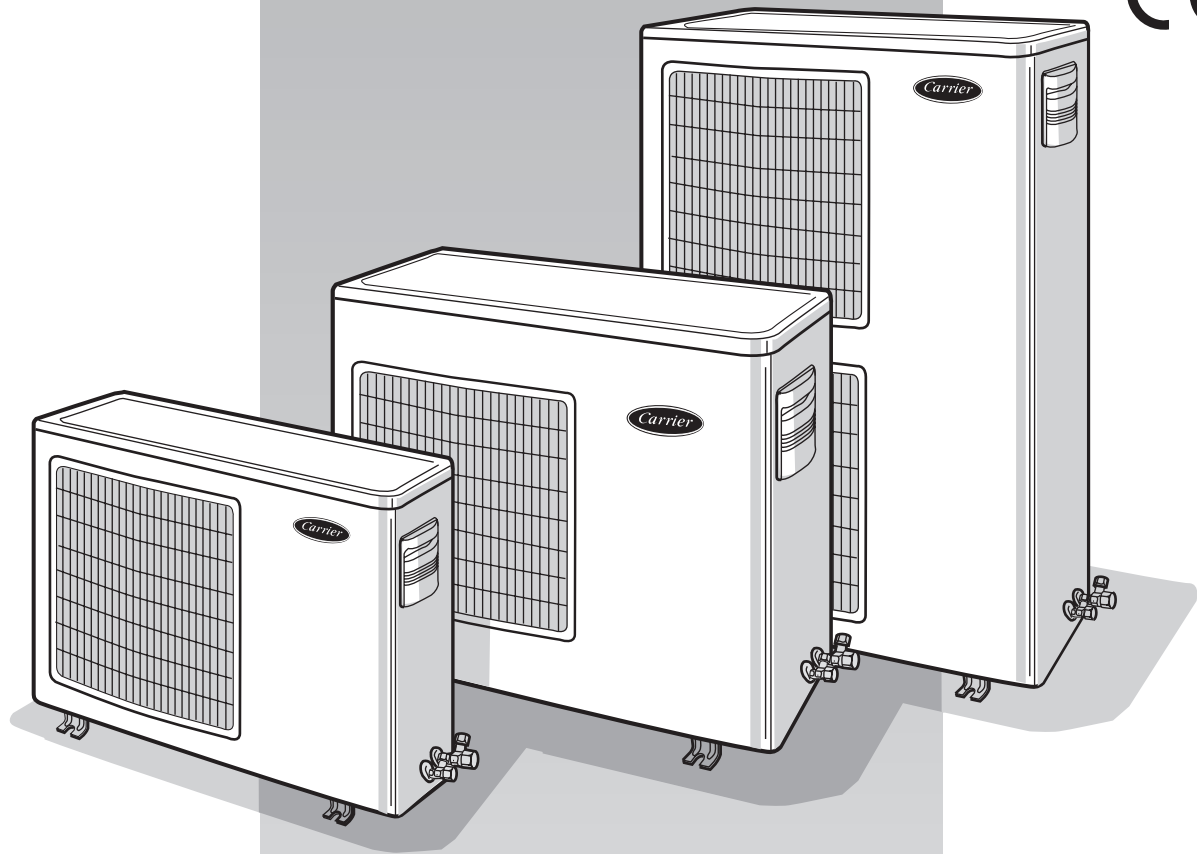

R-410A

INSTALLATION MANUAL

38GL...G / 38GLS...G / 38YY...G / 38YYs...G R-410A

Cooling only and heat pump split system outdoor units

For operation and maintenance instructions of this unit as well as installation instructions of the indoor unit, refer to the relevant manuals.

Contents

	Page
Dimensions and weight	2
Connections	2
Minimum clearances	3
Operating limits	3
Accessories	3
General information	4
Warnings: avoid	5
Refrigerant connections	6/8
Electrical connections	9/10
Electrical data	10
Pump down and refrigerant circuit	11
Unit maintenance	12
Troubleshooting and guide for the owner	12

ATTENTION INSTALLERS AND SERVICE TECHNICIANS! AIR CONDITIONER WITH R-410A—QUICK REFERENCE GUIDE

- R-410A refrigerant operates at 50%-70% higher pressures than R-22. Be sure that servicing equipment and replacement components are designed to operate with R-410A.
- R-410A refrigerant cylinders are pink.
- R-410A refrigerant cylinders have a dip tube which allows liquid to flow out with the cylinder in a vertical position with the valve at the top.
- R-410A systems should be charged with liquid refrigerant. Use a commercial type metering device in the manifold hose in order to vaporize the liquid refrigerant before it enters in the unit.
- R-410A, as other HFCs, is only compatible with oils selected by the compressor manufacturer.
- A vacuum pump is not enough to remove moisture from oil.
- Oils absorb moisture rapidly. Do not expose oil to atmosphere.
- Never open system to atmosphere while it is under vacuum.
- When the system must be opened for service, break vacuum with dry nitrogen and replace filter driers.
- Do not vent R-410A into the atmosphere.
- Use only Carrier matching indoor units (Table I).

Unit size	Oil type	Quantity cc	Drier already installed on liquid line of the unit
018 - 024	POE	1120	YES
028 - 036	POE	1250	YES
048	POE	1400	YES

Table I

Cooling only(A/C) Cooling only	Heat pump (H/P) Heat pump	Hi-Wall series “42PHQ---N”	Hi-Wall series “42HMC---N”	Console series “42VMC---N”	Cassette series “40KMC---N”	Satellite “40SMC---N”	Power supply
38GL(S)018G	38YY(S)018G	42PHQ018N	42HMC018N	42VMC018(A)*N	40KMC018N	40SMC018N	230V ~ 50Hz
38GL(S)024G	38YY(S)024G	42PHQ024N	42HMC024N	42VMC024(A)*N	40KMC024N	40SMC024N	
38GL028G	38YY-028G	—	—	42VMC028 N	40KMC028N	40SMC028N	
38GL036G	38YY-036G	—	—	42VMC036 N	40KMC036N	40SMC036N	
38GL048G	38YY-048G	—	—	42VMC048 N	40KMC048N	40SMC048N	

*(A)= Aluminium version

38GL...G / 38GLS...G / 38YY...G / 38YYs...G R-410A

Dimensions and weight

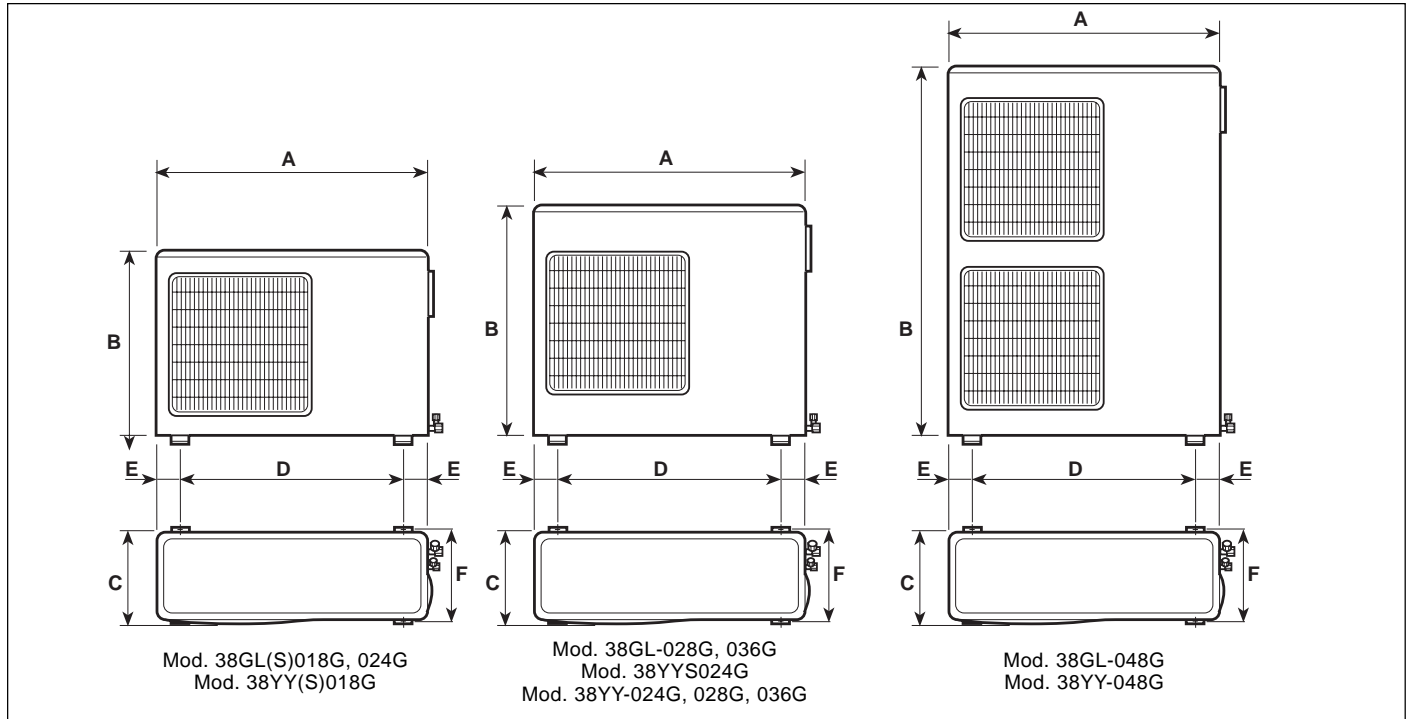

Mod.	38GL(S)018G, 024G 38YY(S)018G		38YY(S)024G		38GL-028G, 036G 38YY-028G, 036G		38GL-048G 38YY-048G	
	18		24		28 36		48	
A mm	800		800		800 800		800	
B mm	590		803		803 803		1264	
C mm	300		300		300 300		300	
D mm	508		508		508 508		508	
E mm	146		146		146 146		146	
F mm	330		330		330 330		330	
kg	46		52		67 68		94	

Connections

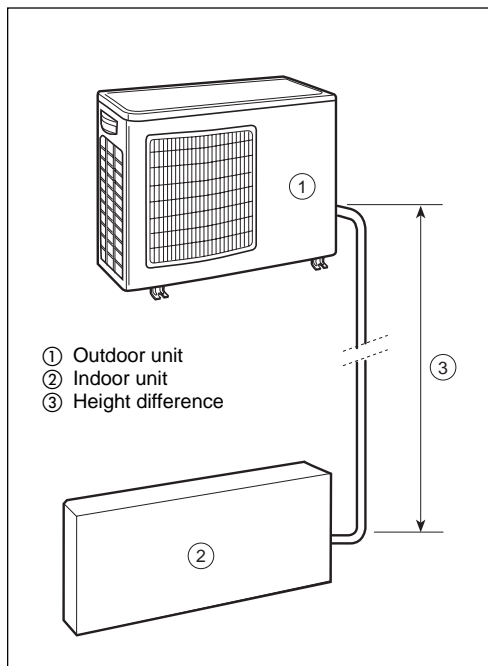

Table II: Connections

	Model				
	18	24	28	36	48
Max. height difference	30 m	40 m	40 m	40 m	50 m
Max. pipe length	10 m	15 m	25 m	30 m	30 m

All fittings are flare type.

Use only refrigeration grade pipes, (Cu DHP type according to ISO 1337), seamless, degreased, deoxidized and suitable for operating pressures of at least 4200 kPa and with a burst pressure of 20700 kPa.

Under no circumstances must sanitary type copper pipe be used.

Mod.	Pipe diameter Gas Liquid (Suction) (Liquid) mm		Pipe diameter Gas Liquid (Suction) (Liquid) inches	
	18	12.70	6.35	1/2"
24	15.87	6.35	5/8"	1/4"
36	19.05	9.52	3/4"	3/8"
48				

Minimum clearances

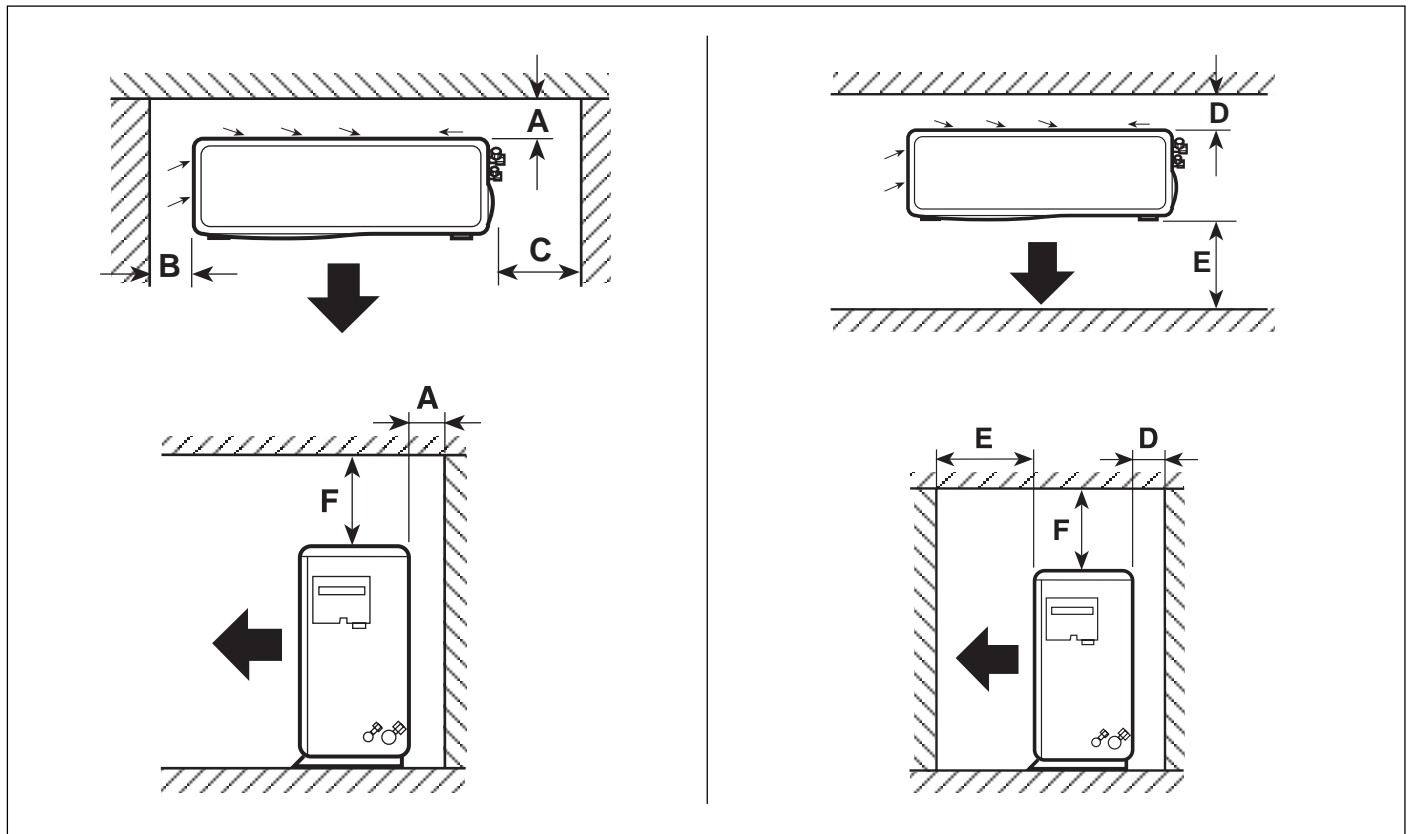

Mod.	18	24	28	36	48
A mm	50	100	100	100	100
B mm	250	250	250	250	250
C mm	500	500	500	500	500
D mm	50	50	100	100	100
E mm	470	470	670	670	670
F mm	400	400	400	400	400

System charge

Model	Refrigerant charge (g)	Suitable up to m	Extra charge g/m	Extra charge (g) with indoor unit	
				42VMC---(A)N	40SMC---N
38GL(S)018G	1090	8	15	–	–
38GL(S)024G	1265	8	15	220	150
38GL(S)028G	2100	8	30	–	100
38GL(S)036G	1980	8	40	–	450
38GL(S)048G	3300	8	70	–	300
38YY(S)018G	1530	8	15	–	–
38YY(S)024G	1900	8	30	370	150
38YY(S)028G	2340	8	30	–	100
38YY(S)036G	2190	8	40	–	450
38YY(S)048G	3650	8	70	–	300

General information

Unit installation

R-410A systems operate at higher pressures than standard R-22 systems. Do not use R-22 service equipment or components on R-410A equipment.

Read this instruction manual thoroughly before starting the installation.

- This unit complies with low-voltage (EEC/73/23) and electromagnetic compatibility (EEC/89/336) directives.
- Check that the impedance of the mains power supply is in conformance with the unit power input indicated in the electric data table IV, on page 10 (EN 61000-3-11).
- The installation must be carried out by a qualified installer.
- Follow all current national safety code requirements. In particular ensure that a properly sized and connected ground wire is in place.
- Check that voltage and frequency of the mains power supply are those required; the available power must be adequate to operate any other possible appliances connected to the same line. Also ensure that national safety code requirements have been followed for the mains supply circuit.
- The mains supply must be connected to the outdoor unit.
- Connect indoor and outdoor units with field-supplied copper pipes by means of flare connections. Use insulated seamless refrigeration grade pipe only, (Cu DHP type according to ISO1337), degreased and deoxidized, suitable for operating pressures of at least 4200 kPa and for burst pressure of at least 20700 kPa. Under no circumstances must sanitary type copper pipe be used.
- After installation thoroughly test the system operation and explain all system functions to the owner.
- Leave this manual with the owner for consultation during future periodic maintenance.
- Use this unit only for factory approved applications.
- This installation manual describes the installation procedures of the outdoor unit of a residential split system consisting of two units manufactured by Carrier. Consult factory or a qualified system engineer prior to connecting this unit to any other manufacturer's indoor unit. Coupling units which have different control systems, may cause irreversible damage and void the warranty protection. The manufacturer declines any liability for system malfunction resulting from unapproved coupling.

IMPORTANT:

During the unit installation make first refrigerant connections and then electrical connections. If unit is uninstalled first disconnect electrical cables, then refrigerant connections.

WARNING:

Disconnect the mains power supply switch before servicing the system or handling any internal parts of the unit.

- The manufacturer declines any liability for damage resulting from modifications or errors in the electrical or refrigerant connections.
- Failure to observe the installation instructions or use of the unit under conditions other than those indicated in Table III "Operating limits", will immediately void the unit warranty.
- Failure to observe electric safety codes may cause a fire hazard in case of short circuits.
- Inspect equipment for damage due to improper transportation or handling: file an immediate claim with the shipping company. Do not install or use damaged units.
- In case of any malfunctioning turn the unit off, disconnect the mains power supply and contact a qualified service engineer.
- This equipment contains R-410A refrigerant, a substance that is not depleting the ozone layer.
- All of the manufacturing and packaging materials used for your new appliance are compatible with the environment and can be recycled.
- Dispose of the packaging material in accordance with local requirements.
- This equipment contains refrigerant that must be disposed of in a proper manner. When disposing of the unit after its operational life, remove it carefully. The unit must then be delivered to an appropriate disposal center or to the original equipment dealer.

- Carefully recover refrigerant within this unit before final disposal or when servicing. Never vent refrigerant to atmosphere. Use approved recovery equipment for R-410A refrigerant. Do not use R-22 equipment.

Choosing the installation site

Positions to avoid:

- Exposed to direct sun.
- Too close to sources of heat radiation, vapour or flammable gas.
- Particularly dusty areas.

Recommendations:

- Choose a position protected from opposing winds.
- Choose a position sheltered from direct sun.
- Choose an area where air outlet and unit noise will not bother your neighbours.
- Choose a position that allows for the clearances required.
- Floor structure should be adequately strong to support unit weight and minimize vibration transmission.
- Consider a position which will not obstruct passageways or doors.

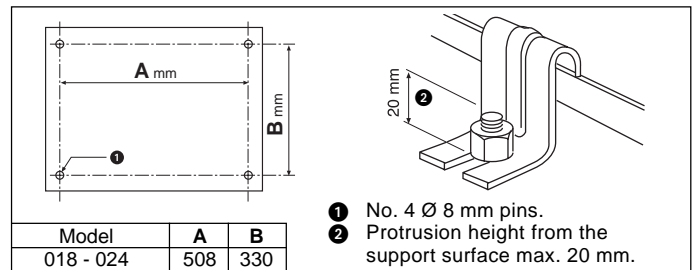

- Fix the unit with locally purchased bolts buried in the block to prevent overturning due to strong gusts of wind.

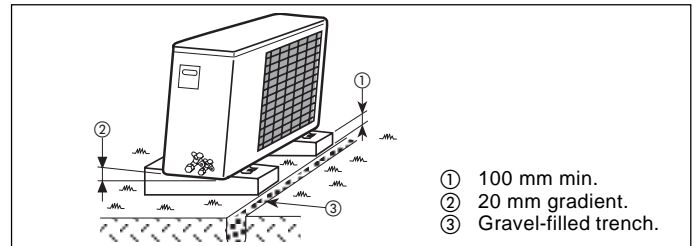

- Unit must be adequately raised above floor surface.

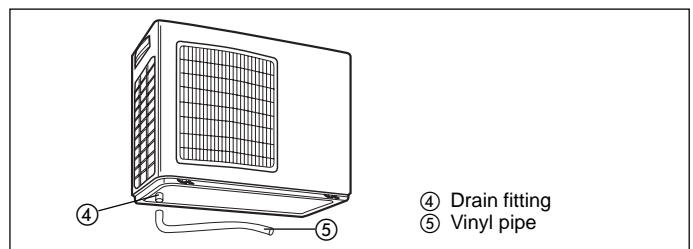

- To drain the condensate water to a drain while operating in heating mode, insert the drain fitting into the hole underneath on the left of the base and use a vinyl pipe with a 16 mm internal diameter. It must not be used at temperatures lower than 0°C. (not supplied for low temperature versions).

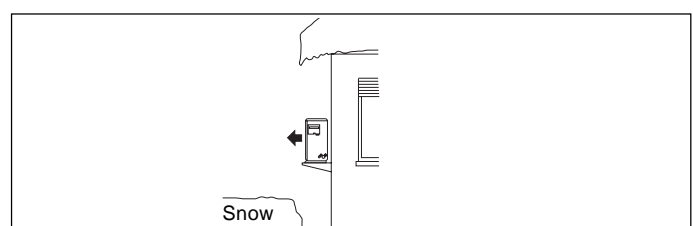

- If the unit is installed in areas where heavy snowfalls may occur, it is necessary to raise its level at least 200 mm above the usual snow level or alternatively to use the outdoor unit bracket kit.

Warnings: avoid....

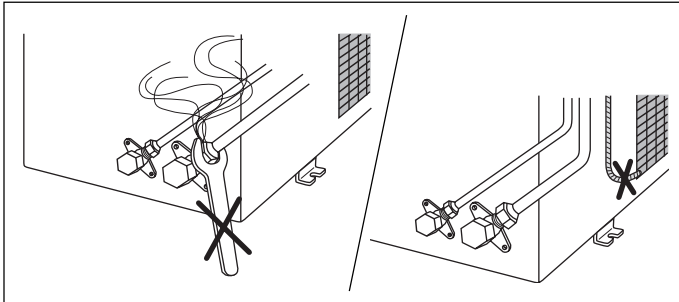

Disconnecting the refrigerant connections after installation: this will cause refrigerant leaks.
Connecting the condensate drain pipe to the outdoor unit.

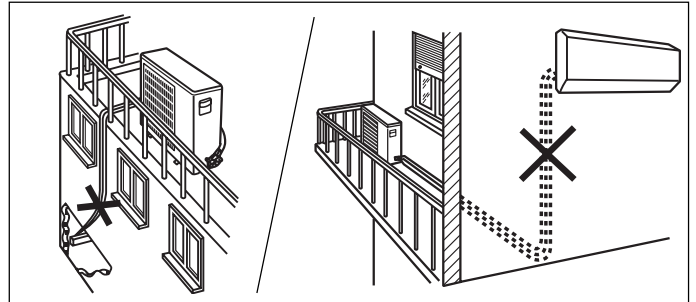

Excessive height difference between indoor and outdoor unit (see Table II "Connections"). Excessive distance between indoor and outdoor units. (see Table II "Connections").

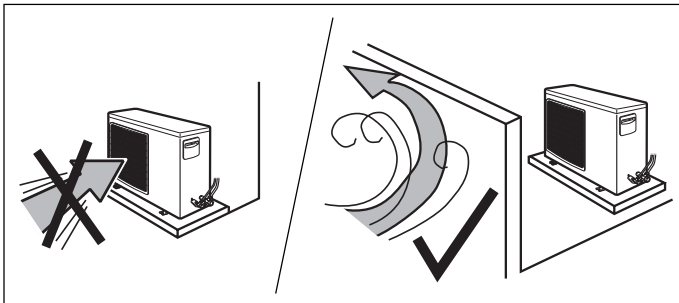

Predominant head winds.

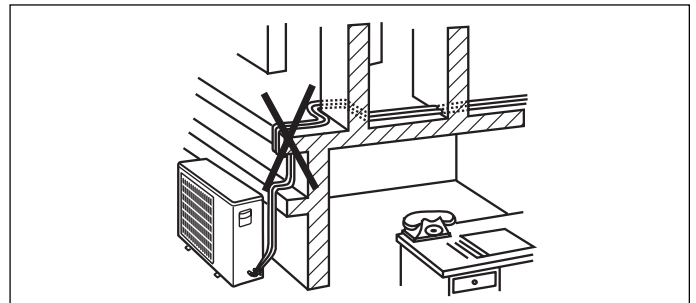

Unnecessary turns and bends in the connecting pipes.

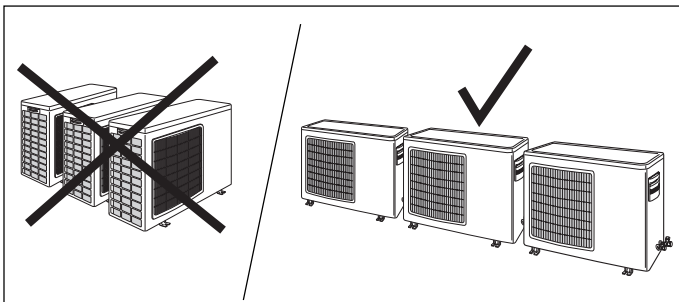

Multiple unit installation with units facing each other.

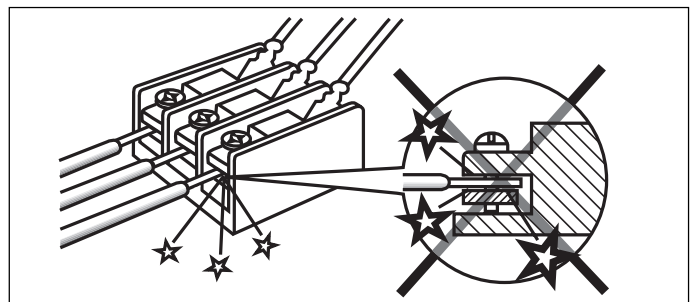

Any slack in the electrical connections.

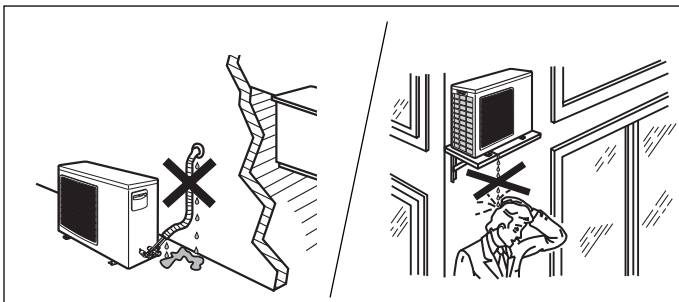

Insulating the connecting pipes only partially, which will cause dripping. Dripping into passageways.

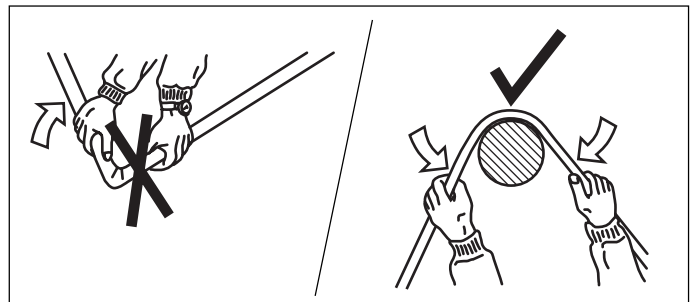

Flattening or kinking of refrigerant or condensate pipes.

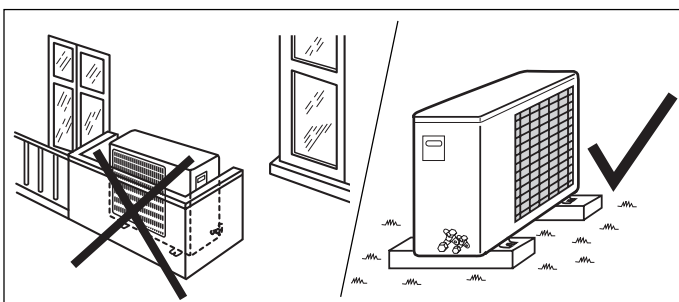

Any obstruction of the unit air outlet and intake or any obstacle that is too close (see minimum clearances required). Installation on grassy ground or soft surfaces (in these cases a solid foundation must be included).

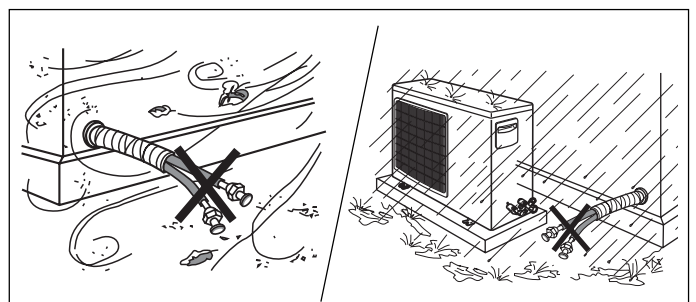

Soiling of pipe ends.
Allowing piping to get wet before connection.

Refrigerant connections

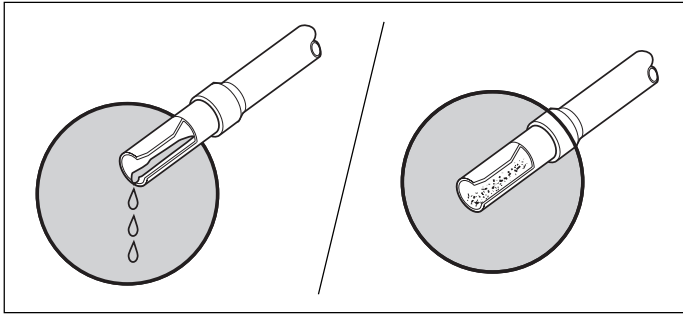

No moisture.
No dust.

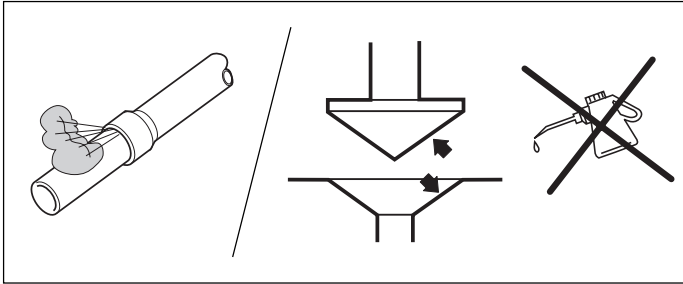

No leak.
No mineral oil.

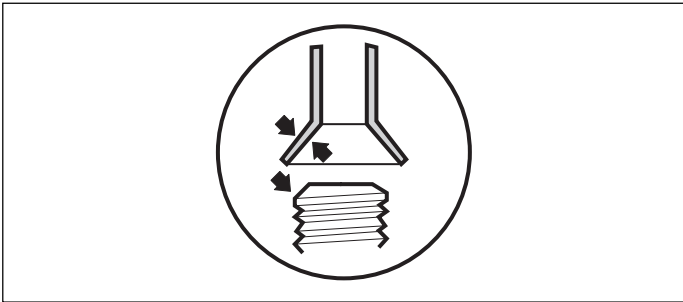

Neat.

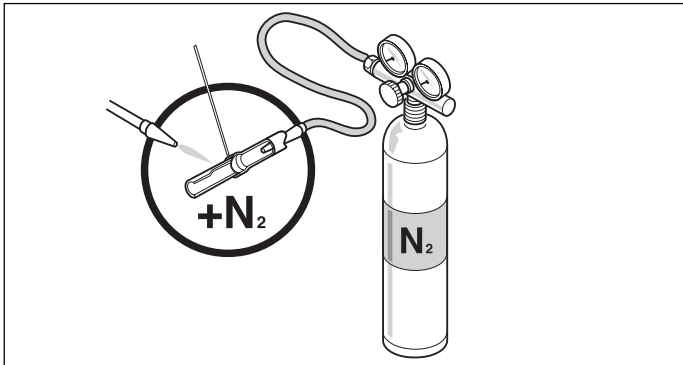

Dry nitrogen brazing.

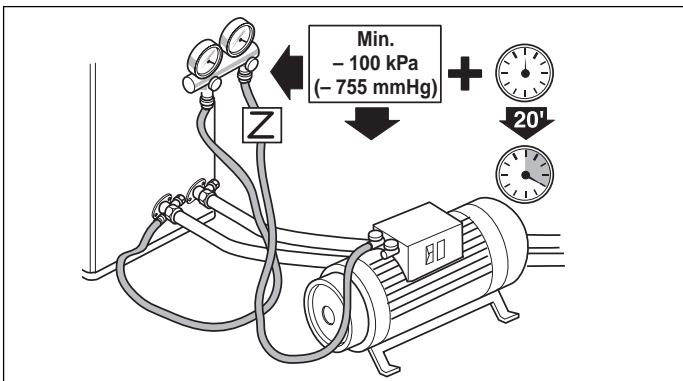

Vacuum.

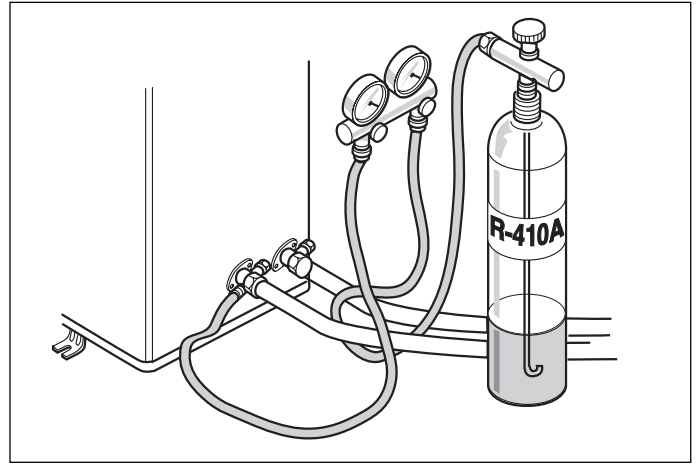

Charge liquid-no gas.

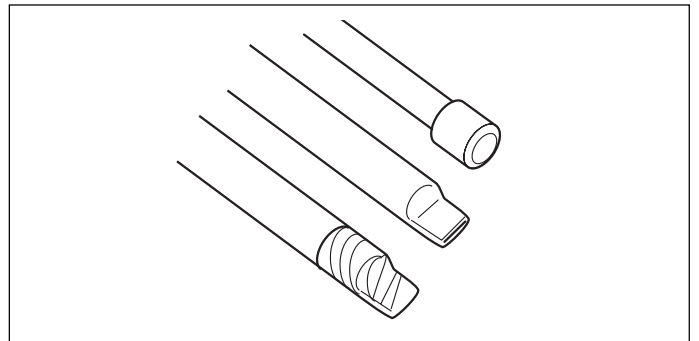

Copper tubes during storage.

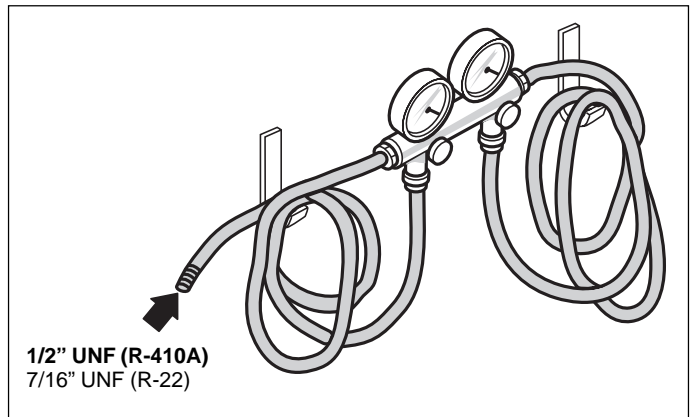

Use tools designed for R-410A higher pressure.
Keep inside clean.

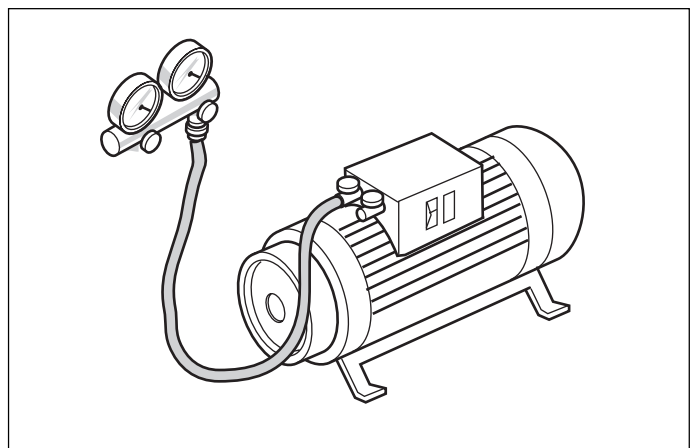

2-stage vacuum pump. Replace oil regularly.

Refrigerant connections

Flaring the ends of the tubing

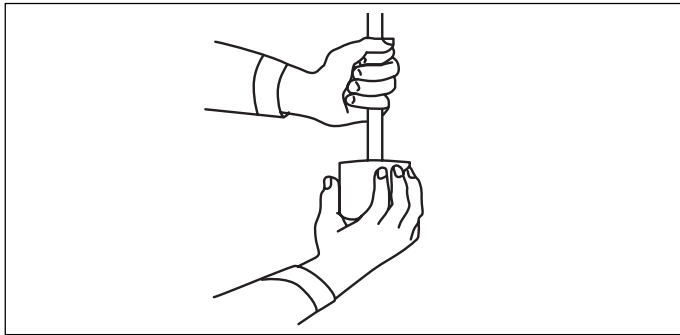

Remove protective caps from copper tube ends. Position tube end downward, cut the tube to the requested length and remove the burrs with a reamer.

Do not leave system open to atmosphere any longer than minimum required for installation.

Oil in the compressor is extremely susceptible to moisture absorption.

Always keep ends of tubing sealed during installation.

The maximum residual quantity of oil used for tubing is 40 mg/10 m.

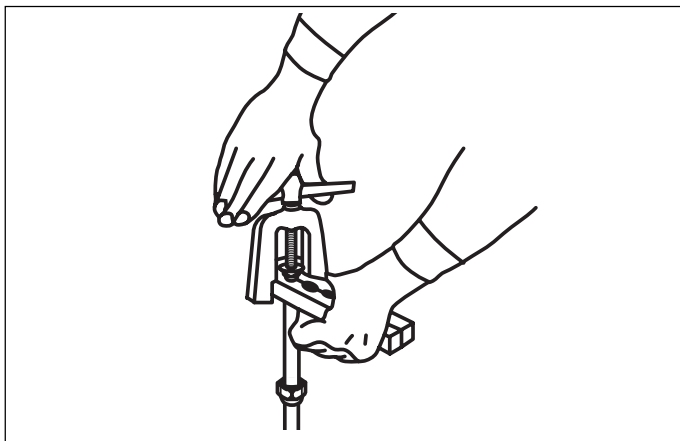

Remove flare nuts from the unit connections and place them on the tube end.

Flare the tube with the flaring tool.

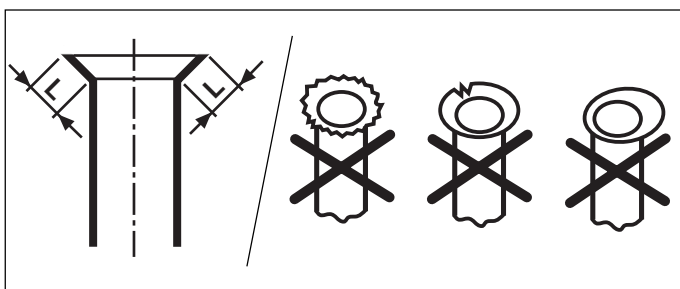

Flare end must not have any burrs or imperfections. The length of the flared walls must be uniform.

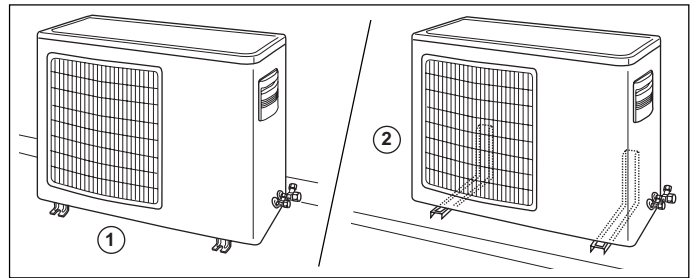

The unit can be installed:

- ① on the floor;
- ② on the wall using the bracket kit.

Connect tubing in accordance with the limits shown on Table II (Connections).

Finger-tighten the fitting several turns, then tighten it with a wrench by applying the tightening torque indicated in the table.

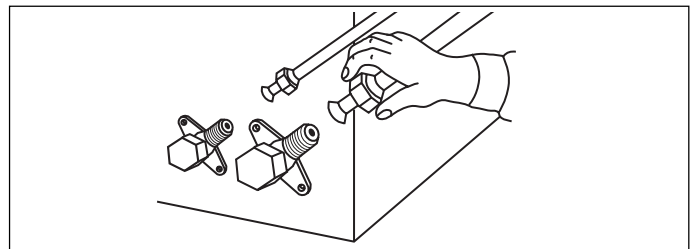

Where required, the unit must be charged with additional refrigerant.

Additional charge must be added using electronic scales and the service port (5/16") on the suction line.

Charge refrigerant only in liquid phase (bottle turned upside down or using the specific connection on bottle; see page 1).

Connection to unit

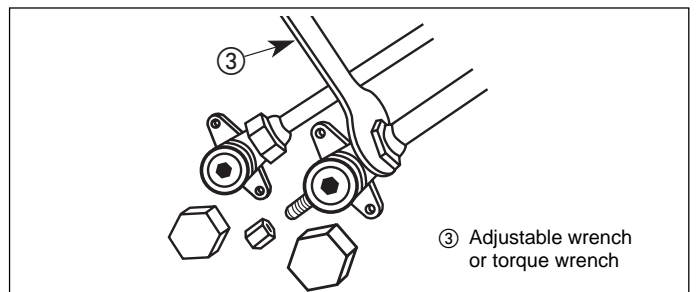

Insufficient tightening torque will cause gas leaks.

Overtightening the fittings will damage the tube flaring and cause gas leaks.

Pipe diameter	Tightening torque Nm
6.35 mm (1/4")	18
9.52 mm (3/8")	42
12.70 mm (1/2")	55
15.87 mm (5/8")	65
19.05 mm (3/4")	100

Tightening torque										
Valve	Flare nut		Valve cap		Pressure port cap		Valve needle		Pressure port	
	Wrench mm	Nm	Wrench mm	Nm	Wrench mm	Nm	Wrench mm	Nm	Wrench mm	Nm
1/4"	17	18	23	20	18	16 - 18	Allen (hex.) 5	9	-	0.34
3/8"	22	42	23	20	18	16 - 18	Allen (hex.) 5	9	-	0.34
1/2"	26	55	29	40	18	16 - 18	Allen (hex.) 5	13	-	0.34
5/8"	29	65	29	40	18	16 - 18	Allen (hex.) 5	13	-	0.34
3/4"	36	100	38	40	18	16 - 18	Allen (hex.) 5	13	-	0.34

Refrigerant connections

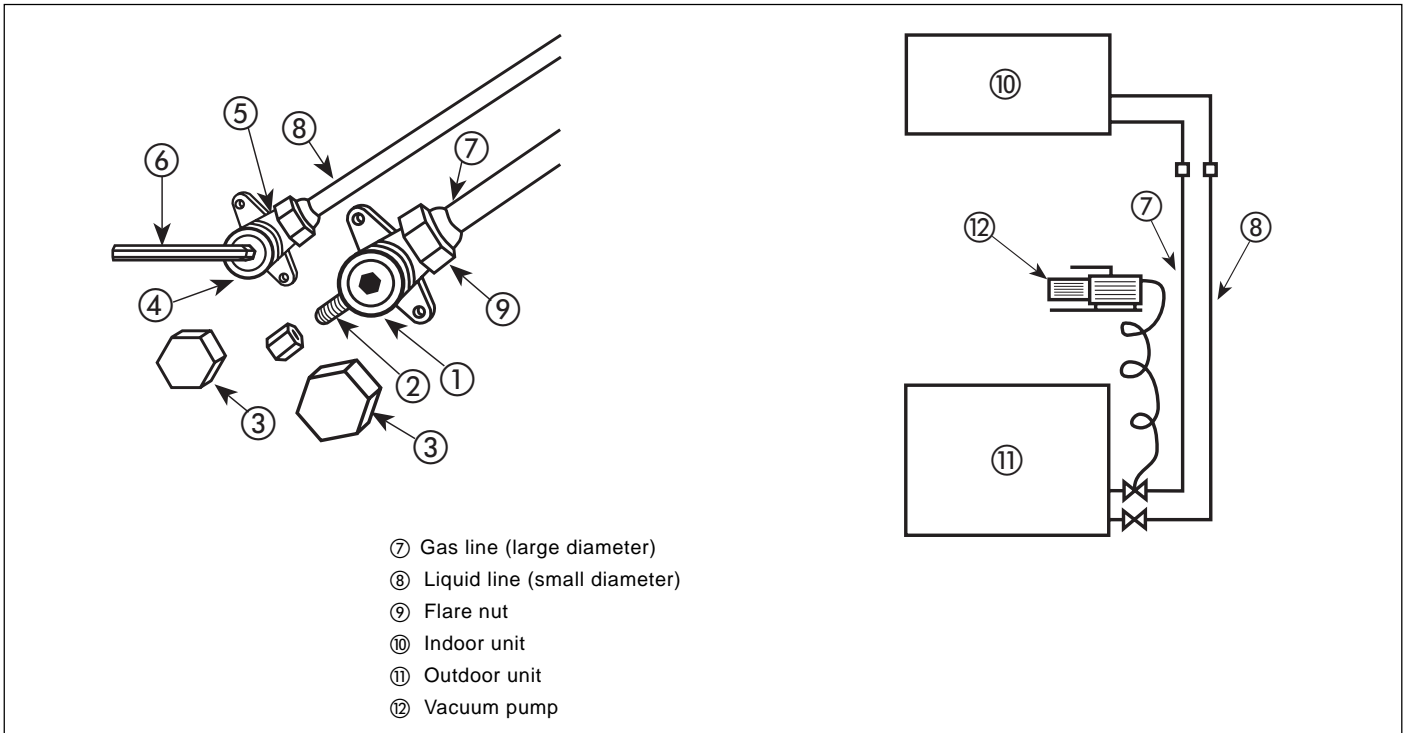

Air purging

Use only a vacuum pump to purge air from the piping.

NEVER use the system compressor as a vacuum pump.

NEVER use the unit refrigerant gas to purge the connecting pipes.

No additional refrigerant has been provided in the unit for this purpose.

Remove the caps from the two and three-way valves.

Create a vacuum with a vacuum pump connected to the service connection of the suction shut-off valve, as shown, keeping the shut-off valves completely shut until a 50 Pa (0.5 mbar) vacuum has been reached.

Now open the two-way valve for 3 sec., then quickly shut it to check for possible leaks.

After the leak check, fully open the two and three-way valves. Replace caps and check for leaks.

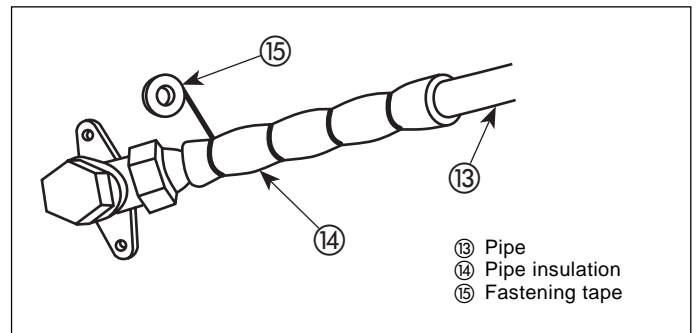

Once all connections have been completed, check for leaks by using a leak detector specific for HFC refrigerants. Finally wrap the valves and pipes with anti-condensate insulation and tighten this with tape, without exerting too much pressure on the insulation. Repair and cover any possible cracks in the insulation. Fix the pipes to the wall with hooks or conduits.

Table III: Operating limits ⁽¹⁾

Cooling (2)	Maximum conditions	Outdoor temperature 43°C	
	Minimum conditions	Indoor temperature 32°C d.b.; 23°C w.b.	
Heating (3)	Maximum conditions	Outdoor temperature 15°C (4)	
	Minimum conditions	Indoor temperature 21°C d.b.; 15°C w.b.	
Mains power supply	Nominal single-phase voltage	230V ~ 50Hz	220V-240V ~ 60Hz
	Operating voltage limits	min. 198V – max. 264V	

- Notes:**
- Data referred to the outdoor unit only.
 - According to ISO 5151.2/T1.
 - According to ISO 5151.2/High+.
 - The units 38YYS018 and 38YYS024 are equipped with a high pressure cut-out, which is suitable for outdoor temperatures up to -15°C.

d.b. - dry bulb **w.b.** - wet bulb

WARNING:

During heat pump operation unit will undergo several defrost cycles to eliminate ice that might possibly collect on the outdoor unit in very low ambient temperatures. In these cycles, fan speed will automatically reduce and cannot be varied until defrost cycle is completed.

Electrical connections

Cooling only unit

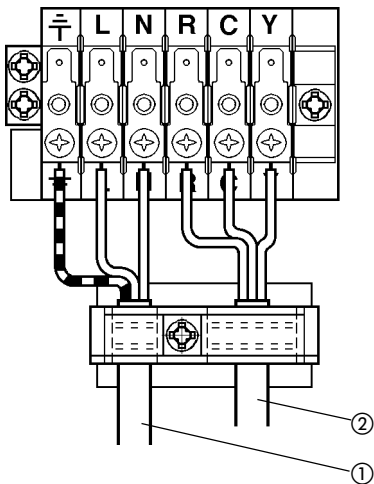

Cooling only system

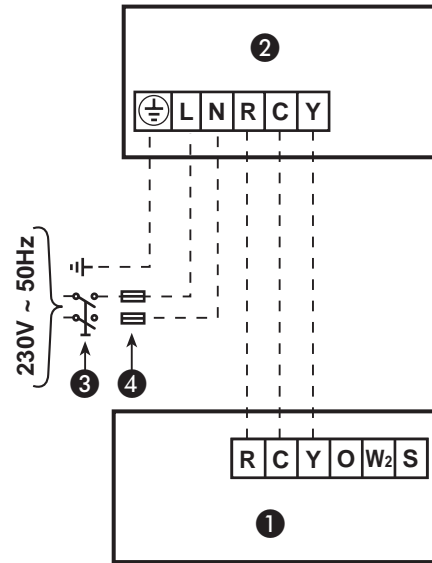

Terminal box legend

⊕ Earth.

L Live power supply.

N Neutral power supply.

R Live connection indoor/outdoor unit.

C Neutral connection indoor/outdoor unit.

Y Compressor interlocking contact.

O Reversing valve control.

W2 Outdoor fan signal.

S Defrost end signal.

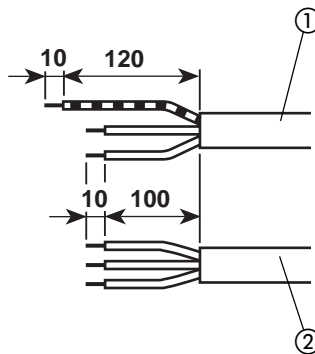

① Power supply cable (H07 RN-F)

② Interconnection cable (A07 RN-F)

① Indoor unit

② Outdoor unit

③ Main switch

④ Time-delay fuse or circuit breaker (see table IV "Electrical data").

Heat pump unit

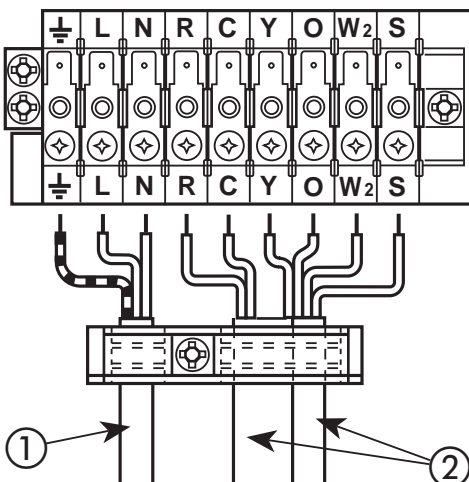

Heat pump system

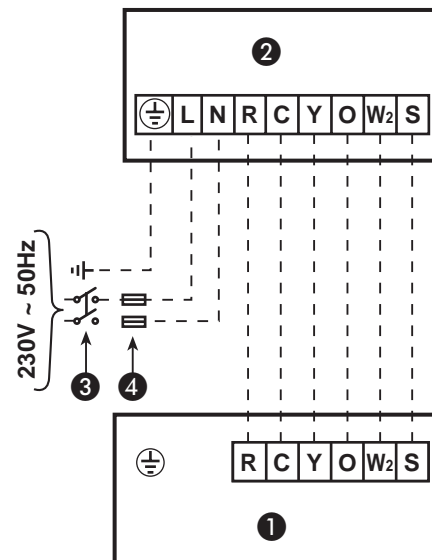

Electrical connections

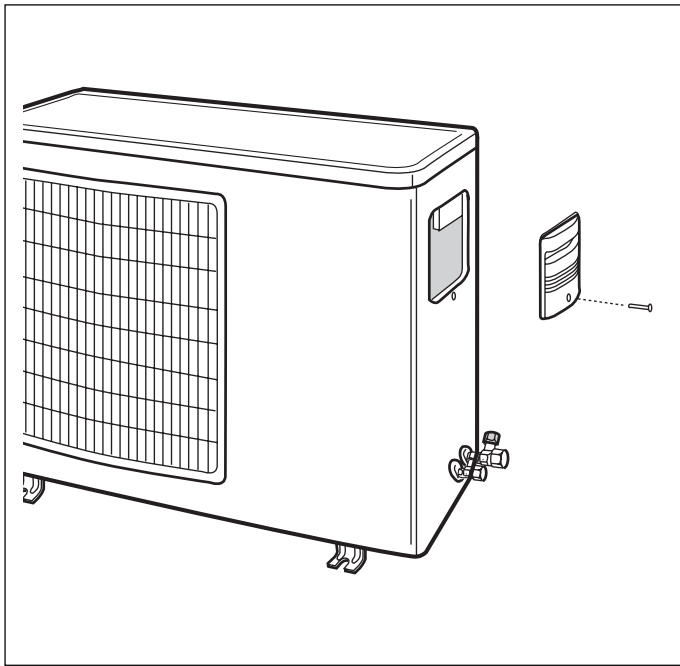

- Remove electric box cover.
- Make electrical connections between units prior to proceeding to mains supply unit connection.
- Connect the wires to the terminals according to the wiring diagram and firmly tighten.
- Before proceeding with the unit connection to the mains supply locate live **L** and neutral **N**, then make connections as shown in the wiring diagram.
- Ensure that mains supply connection is made through a switch that disconnects all poles, with contact gap of at least 3 mm.
- The mains supply connecting cable must be H07 RN-F type (or higher), synthetic rubber insulation with neoprene coating, according to EN 60335-2-40.

Note:
All field electrical connections are the responsibility of the installer.

Refer to the indoor unit installation manual for sizing the connection wires between units.

Note:
After connections have been completed, replace electric box cover.

- **Make refrigerant connections before electrical connections.**
When disassembling, disconnect electrical connections before refrigerant connections.

IMPORTANT:
Make ground connection prior to any other electrical connections.

Table IV: Electrical data

Unit	Starting current (3)	Power input (2)								Main power connections (6)	
		Cooling				Heating				Time-delay fuse gL type	Wire size (4-5)
		Nominal conditions 230V ~ 50Hz ISO 5151.2/T1 indoor 27°C d.b. 19°C w.b. outdoor 35°C d.b. 24°C w.b.		Peak conditions 198V ~ 50Hz ISO 5151.2/T1 indoor 32°C d.b. 23°C w.b. outdoor 43°C d.b. 32°C w.b.		Nominal conditions 230V ~ 50Hz ISO 5151.2/High+ indoor 20°C d.b. 15°C w.b. outdoor 7°C d.b. 6°C w.b.		Peak conditions 198V ~ 50Hz ISO 5151.2/High+ indoor 27°C outdoor 24°C d.b. 18°C w.b.			
A	W	A	W	A	W	A	W	A	mm ²		
38GL(S)018G	40	9,3	2110	13,1	2560	–	–	–	–	20	2,5
38GL(S)024G	60	10,1	2300	15,5	3100	–	–	–	–	25	2,5
38GL-028G	70	13,9	3030	18,9	3600	–	–	–	–	16	4
38GL-036G	76	14,9	3250	19,4	3700	–	–	–	–	16	4
38GL-048G	114	15,8	3450	28,2	5350	–	–	–	–	16	6
38YY(S)018G	40	8,8	1980	12,4	2430	8,9	2015	11,8	2300	20	2,5
38YY(S)024G	60	11,4	2465	14,9	2890	12,2	2675	14,3	2775	25	2,5
38YY-028G	70	13,4	2940	19,5	3800	14,1	2680	16,9	3890	30	4
38YY-036G	76	15,7	3430	19,9	4020	15,9	3030	20,0	3960	32	4
38YY-048G	114	17,7	3860	28,7	5450	17,5	3320	25,7	4900	40	6

Notes: 1. Unit is suitable for outdoor installation.

2. Data referred to the outdoor unit only.

3. Starting current duration is usually lower than 1 sec.

4. Wire size shown applies to line length up to 15 m.

5. If the indoor unit is provided with an electric heater, consult indoor unit installation manual for correct sizing of the wires.

6. The mains supply connecting cable must be H07 RN-F type (or higher), synthetic rubber insulation with Neoprene coating, according to EN 60335-2-40 codes.

Pump Down and refrigerant circuit

Pump-down

Pump-down is an operation intended to collect all the system refrigerant in the outdoor unit.

This operation must be carried out before disconnecting the refrigerant tubing in order to avoid refrigerant loss to the atmosphere, if it becomes necessary to disconnect the refrigerant connections for unit repair, removal or disposal; in this case, after removal, unit must be delivered to an appropriate disposal centre or the original dealer.

Shut off the liquid valve with the Allen wrench.
Turn the system on in cooling with fan operating at high velocity. (Compressor will immediately start, provided 3 minutes have elapsed since the last stop).
After 2 minutes of operation, shut the suction valve with the same wrench.
Turn the system off and switch mains supply off.

Disconnect tubing. After disconnection, protect valves and tubing ends from dust.
Compressor damage may occur if run at a negative suction pressure.

Refrigerant circuit

Cooling only unit

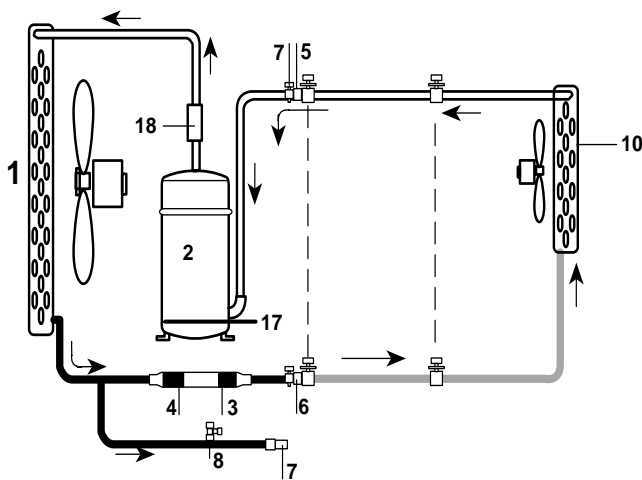

Heat pump system

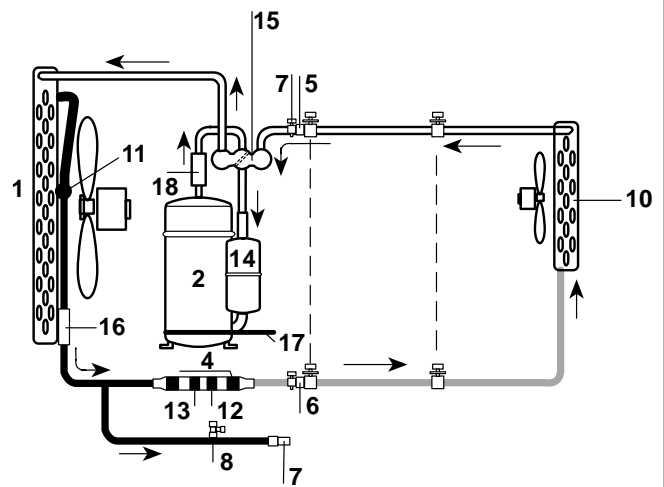

Cooling cycle

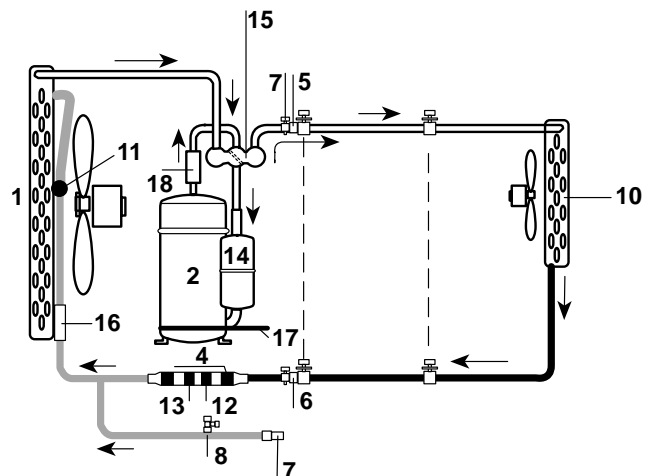

Heating cycle

Legend:

- ① Outdoor coil
- ② Compressor
- ③ Metering device
- ④ Strainer
- ⑤ Vapor valve
- ⑥ Liquid valve
- ⑦ Service pressure port
- ⑧ Additional pressure port
- ⑩ Indoor unit coil
- ⑪ Liquid distributor
- ⑫ Cooling metering device
- ⑬ Heating metering device
- ⑭ Additional suction accumulator
- ⑮ Reversing valve
- ⑯ Defrost end thermostat
- ⑰ Crankcase heater
- ⑱ Discharge muffler

- Gas
- Liquid + Gas
- Liquid

Unit maintenance, troubleshooting and guide for the owner

Unit maintenance

The following maintenance operations must be carried out by qualified personnel.

Cleaning the coil

When necessary, proceed as follows for more careful cleaning of the coil:

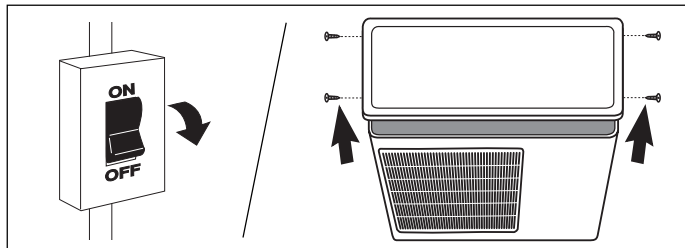

Switch the mains supply OFF.

Remove unit top cover by loosening holding screws and lifting the cover.

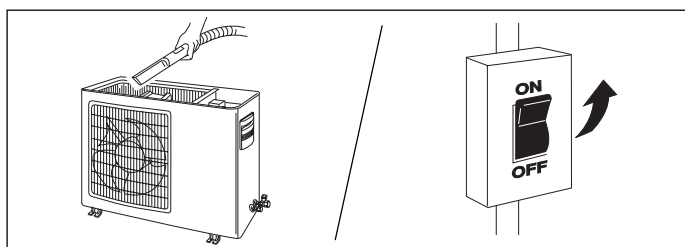

Carefully clean the coil with a vacuum cleaner from inside to outside. With the same vacuum cleaner, dust the inside of the fan compartment and the fan blades. Avoid any damage to the blades which may cause future vibrations and noise. Replace the unit cover and tighten the screws.

After long shutdown periods and at commissioning (for heat pump models only)

Energize the system by putting the main switch to ON without starting the unit. (Remote control must be in the OFF position). Do not disconnect the main switch during the unit operating season.

Troubleshooting

Compressor and fan of the outdoor unit will not start:

- Unit not energized; check the mains power connections.
- Main switch OFF; check and put to the ON position.
- Main switch fuses have blown; replace.
- Wait for 3 minutes; compressor cycling protection is on.
- Pressure switch open; check and eliminate cause.
- Mains voltage too low.
- Electrical connections loose or wrong; check and repair.

Compressor will not start, but outdoor fan is running:

- Electrical connections of compressor loose or wrong; check and repair.
- Compressor burnt out, seized or protection device on; check for the cause and replace compressor if necessary.
- Run capacitor faulty (single-phase models); replace.

Compressor starts, but stops due to its overtemperature protection (other than stops caused by the normal operation of the thermostat):

- Wrong refrigerant charge (excessive or low) or air or other non condensable gases in the circuit; drain refrigerant (see note 1), evacuate and recharge.
- Mains voltage wrong (too high or too low).
- Condenser coil (outdoor or indoor, in case of heat pump operation) obstructed; remove obstructions.
- Outdoor fan off; check cause and repair.
- Run capacitor faulty; check and replace.
- Refrigerant circuit clogged; check and remove obstructions.
- Reversing valve faulty on heat pump models; replace.
- Expansion device clogged or covered with ice; drain refrigerant (see note 1), evacuate and recharge.

Compressor runs continuously:

- Unit selected too small for actual air conditioning needs.
- Indoor temperature selection too low (if in cooling) or too high (if in heating, for heat pump models); check temperature selection.
- Refrigerant charge low; check and add refrigerant.
- Condenser fan (outdoor or indoor, in case of heat pump operation) faulty; replace.
- Air or other non condensable gases in the circuit; drain refrigerant (see note 1), evacuate and recharge.
- Obstructions at air intake or dirty indoor unit filters; remove obstruction or clean filter.

Frequent ice build-up on outdoor coil (during heating with heat pump units):

- Outdoor fan stopped; check cause and repair.
- Wrong electrical connections between indoor and outdoor units; check electrical connections and repair.
- Check defrost end thermostat positioning and connection.

Discharge pressure too high:

- Outdoor coil dirty or obstructed; clean or remove obstructions.
- Condenser fan (outdoor or indoor, in case of heat pump operation) faulty; replace.
- Refrigerant charge too high; drain some refrigerant (see note 1).
- Air or other non-condensable gases in the circuit; drain refrigerant (see note 1), evacuate and recharge.

Discharge pressure too low:

- Refrigerant charge too low; add refrigerant.
- Outdoor coil dirty or obstructed; clean or remove obstructions.
- Indoor unit air filter dirty; clean filter.

Suction pressure too high:

- Refrigerant charge too high; drain some refrigerant (see note 1).
- Reversing valve faulty or internal leak; replace.

Suction pressure too low:

- Refrigerant charge too low; add refrigerant.
- Evaporator coil (indoor or outdoor, in case of heat pump models), covered with ice; see the following points.
- Air circulation on the evaporator unit (indoor or outdoor, in case of heat pump models) not sufficient; check for the cause and repair.
- Expansion device or suction line clogged; check and repair.
- Outdoor fan does not stop during defrost periods (when heating with heat pump models); check electrical connections.

Outdoor fan cycling due to its overtemperature protection:

- Fan capacitor faulty; replace.
- Electrical connection loose; check connections.
- Fan bearing seized; check and repair.

Outdoor fan motor running always at low speed:

- Wiring not connected to the board; check connections between temperature sensor and board.
- Temperature sensor is faulty; replace the sensor.
- Electronic board broken; replace board.

Outdoor fan motor running always at high speed:

- Temperature sensor is short circuited; replace temperature sensor.
- Electronic board broken; replace board.

Note 1: Do not release refrigerant to the atmosphere; use refrigerant recovery equipment.

Guide for the owner

When installation and tests are completed explain the Operation and Maintenance Manual to the owner, with particular attention to the main operating modes of the air conditioner, such as:

- Turning the unit on and off.
- Functions of the remote control.
- Removal and cleaning of the air filters.

Leave the two installation manuals for the indoor and outdoor units with the owner for future use during maintenance operations or for any other needs.



Via R. Sanzio, 9 - 20058 Villasanta (MI) Italy - Tel. 039/3636.1

The manufacturer reserves the right to change any product specifications without notice.

Order No. 13881-74M10, March 2003 . Supersedes Order No. 13881-74M10, October 2002

Printed in Italy