

Handy Printer
PD-22

User's Manual



Latest Information

Printer Drivers, Servicing and Consumables

For the latest information on your PD-22 printer:

- where to obtain service inside or outside of the warranty period
- printer drivers for the latest operating systems
- additional consumables and accessories

please contact Citizen's office in your region:

United States, Canada, South America:

Citizen Systems America Corporation
www.citizen-systems.com
363 Van Ness Way, Suite 404 Torrance, CA 90501. USA
Tel: (310) 781-1460

Europe, Middle East & Africa:

Citizen Systems Europe GmbH
www.citizen-europe.com
UK: Park House, 643–651 Staines Road, Feltham, Middlesex, TW14 8PA
Tel: +44 (0) 20 8893 1900
Germany: Mettinger Strasse 11, D-73728, Esslingen.
Tel: +49 (0) 711 3906 420

Asia

Citizen Systems Japan Co., Ltd.
www.citizen-systems.co.jp
6-1-12, Tanashi-cho, Nishi-Tokyo-shi, Tokyo 188-8511. JAPAN
Tel: +81 (0) 424 68 4608

CITIZEN is a registered trade mark of CITIZEN WATCH CO., LTD., JAPAN
Company names and product names in this manual are trademarks or
registered trademarks of relevant companies.

Copyright © 2009 CITIZEN SYSTEMS JAPAN CO., LTD.

Contents

FCC Declaration of Conformity	4
Declaration of Conformity	5
Compliance Statements	6
Safety Instructions	7
Accessories	14
Included Accessories	14
Optional Accessories	14
External Appearance and Part Descriptions	15
About the Power Source	18
Loading the Batteries	18
Unloading the Batteries	20
Turning the Power On and Off	21
About the Auto Power Off Function	21
Connecting the Printer	22
Data Reception Methods	22
Connecting with the Infrared Port (Optical Interface)	22
Connecting with the Serial Port (Cable)	23
Loading the Paper	24
Loading Roll Paper	24
If the Paper is Not Loaded Straight	25
When Printing is Finished	25
Feeding Single Sheets (Cut sheets)	26
Use of the following single (cut) sheet paper is recommended	26
Printing Test	27
Self-Print Function	27
Hex Dump Function	28
Internal Menu Settings List Print Function	29
Care and Maintenance	30
Troubleshooting	31
Optional AC Adaptor Kit	32
Installing the Battery Adaptor	32
Specifications	33

FCC Declaration of Conformity

We, the Responsible Party: Citizen Systems America Corporation
363 Van Ness Way, Suite 404
Torrance, CA 90501. USA
Tel: (310) 781-1460

declares that the product:

Trade Name: CITIZEN
Product Name: Printer
Model Number: PD-22

confirms to the following specifications:

Regulation: FCC Part 15B, Class B
Test Method: ANSI C63.4-1992

and therefore is in compliance with the protection requirement of FCC Rules relating to electromagnetic compatibility.

issued on 1, Sep., 2009

Authorized Signature: _____

Masao Yamazaki
President

DECLARATION OF CONFORMITY

We, **Citizen Systems Europe GmbH**
Park House
643-651 Staines Road
Feltham, Middlesex
TW14 8PA. United Kingdom



declare under our sole responsibility that the product:

Product Type: Thermal Printer

Model Name: PD-22

manufactured by : Citizen Systems (Jiangmen) Co., Ltd.

399 Jinxing Road, Jiangmen

Guandong, 518122 CHINA

in 2009, to which this declaration relates is in conformity with the following standards:

EMC: EN 55022:1998, EN61000-3-2:2000,

EN61000-3-3:1995+A1:2001, EN 55024:1998

Following the provisions of EMC (2004/108/EC) based on the following documents:

1. EMI Test Report issued by TÜV OHTAMA CO., LTD.
2. Immunity Test Report issued by TÜV OHTAMA CO., LTD.

(European Representative)

London, 1st September 2009



Yasuhiro Kiuchi
Managing Director
Citizen Systems Europe GmbH

Compliance Statements

FCC Compliance Statement for American Users

This equipment has been tested and found to comply with the limits for a Class B digital device, pursuant to Part 15 of the FCC Rules. These limits are designed to provide reasonable protection against harmful interference in a residential installation. This equipment generates, uses, and can radiate radio frequency energy and, if not installed and used in accordance with the instructions, may cause harmful interference to radio communications. However, there is no guarantee that interference will not occur in a particular installation. If this equipment does cause interference to radio or television reception, which can be determined by turning the equipment off and on, the user is encouraged to try to correct the interference by one or more of the following measures:

- Reorient or relocate the receiving antenna.
- Increase the separation between the equipment and receiver.
- Connect the equipment into an outlet on a circuit different from that to which receiver is connected.
- Consult the dealer or an experienced radio/TV technician for help.

CAUTION: Use shielded cables to connect this device to computers.

Any changes or modifications not expressly approved by the grantee of this device could void the user's authority to operate the equipment.

EMI Compliance Statement for Canadian Users

- This Class B digital apparatus complies with Canadian ICES-003.
- Cet appareil numérique de la classe B est conforme à la norme NMB-003 du Canada.

CE Declaration for European Users



CE marking shows conformity to the following criteria and provisions.

- EMC Directive (2004/108/EEC)/EN55022, EN55024, EN61000-3-2 & EN61000-3-3

Safety Instructions

The Symbols

Instructions that must be followed to prevent any risk to the user and other people and any damage to property are indicated as shown below. The degree of risk and damage that will occur if a user operates the machine improperly by failing to obey any of the indicated instructions are categorized as follows. Read the User's Manual after you fully understand this categorization.

 Danger	Indicates a situation where there is a high probability of the death or serious injury of a person.
 Warning	Indicates that if a person uses the machine improperly by failing to obey this instruction, there is a possibility of death or serious injury.
 Precaution	Indicates that if a person uses the machine improperly by failing to obey this instruction, there is a possibility of serious injury or of property damage.

Meaning of symbols



This symbol indicates that something must be handled carefully.



This symbol indicates something that must not be done.



This symbol indicates something that must be done.

■ Precautions to be followed when handling the printer



Warning



- If the printer is used after it has become hot or produced smoke, a strange smell, etc., it will start a fire. Immediately cut off the power, remove its battery, and contact your service representative.
- If any foreign matter (metal scraps, water, or other fluid) gets inside the printer, first cut off the power and remove the battery, then contact your service representative. If you use it in this condition, it will start a fire.



Precaution



- Do not put in on top of a shaky stand or other unstable place. If may fall or topple over causing an injury.
- Neither uses it nor stores it in the following locations. If you do, it will malfunction.
 - In a car that is exposed to the sun, in any place exposed to direct sunlight, near a heater etc.
 - Place where the temperature and humidity are very high or low or where they fluctuate widely.
 - Extremely dusty place
 - Place exposed to water or other fluid
- Do not drop it or vigorously strike or vibrate it. If you do, it will be damaged or malfunction.
- Keep all foreign material out of the printer. This will cause it to malfunction.
- Do not use a volatile fluid (thinner, benzine, etc.) or wet cloth to clean the printer. If you do, it will be degraded or discolored. Clean it with a dry soft cloth.
- During printing or when it is in standby status, do not move, shake or strike the printer. There is a danger that the power will be cut off, losing printing data.

■ Precautions to be followed when operating the printer



Warning



- Be extremely careful not to touch the print head or paper cutter when replacing the paper. When the print head has become heated, there is a danger of it burning your hand. And part of the cutter might cut your hand.



Precaution



- If you use any paper other than the designated kind, the print quality will fall and the service life of the print head (printing unit) will be reduced.
- Do not perform printing and do not push the paper feed button while there is no paper in the printer. The heat of the print head will deform the platen (roller) and friction with the platen will damage the print head.
- Do not tap or rub the print head with a sharp or hard object.



- If moisture has condensed on the print head, be sure to wait until it is completely dry before performing printing. If you print while the print head is moist, there is a danger of damage to the print head.
- Do not use any batteries other than AA rechargeable NiMH batteries, AA rechargeable NiCd batteries, and AA alkaline batteries.
- Always use four identical batteries at the same time.

■ Precautions when using rechargeable batteries



Danger



- If the fluid of a rechargeable battery gets in your eyes, you will be in danger of being blinded, so immediately wash them with clean water without rubbing them and promptly go to a doctor for treatment
- The plus and minus directions of rechargeable batteries are preset. When placing batteries in the printer, check the plus and minus directions. If you do not, the batteries may leak, overheat, or crack.
- If you do not obey the following instructions, the rechargeable battery will leak, overheat, or crack. Be sure to obey the following instructions.
 - Do not place them in a fire or heat them.
 - Do not remove nor scratch their external tube.
 - Do not solder them.
 - Do not throw them or strike them vigorously.
 - Do not touch their plus and minus terminals with a wire or other metal object.
- Do not take apart or modify a rechargeable battery. If a rechargeable battery is taken apart or modified, it will leak, overheat, or crack.



Warning



- If fluid from a rechargeable battery touches your skin or clothing, there is a danger of it harming your skin, so wash it off with clean water immediately.
- Before placing dry cell batteries or rechargeable batteries in the printer, make sure that the covering of the battery has not been removed and is not scratched. Be particularly careful when using the same batteries for a long time.
- If the covering on the surface of batteries has been removed or is scratched, do not use them. If it is, the batteries will short-circuit causing them to leak, overheat, or crack.
- Do not remove or scratch the covering on the surface of the batteries. If you do, the batteries will short-circuit causing them to leak, overheat, or crack.
- Do not use old and new batteries, different kinds of batteries, or batteries made by different makers at the same time.
- When using rechargeable batteries, do not use batteries with different charged conditions at the same time.
- Do not charge and use alkali batteries or lithium batteries that cannot be charged.



Precaution



- Do not touch or moisten rechargeable batteries with fresh water or seawater. If a battery is moistened, it will heat up or rust.
- Do not use or leave rechargeable batteries in hot places. If a rechargeable battery is used or left in a hot place, it will leak, reducing its performance and service life.



- Store rechargeable batteries where they are out of the reach of infants and small children. Be extremely careful that an infant or small child does not take out the rechargeable batteries.
- Use a charger that matches the specifications of each type of battery.
- Be sure to fully charge new rechargeable batteries before using them for the first time.
- After using a machine that is powered by rechargeable batteries, be sure to turn off the machine. If the machine is left standing for a long time with its power on, the batteries will leak.
- When you do not plan to use the printer for a long time, remove its rechargeable batteries.
- If the batteries overheat, emit smoke or a strange odor or other abnormal condition appears during use, take the following actions.
 - ① Quickly turn off the power to the printer and remove the batteries, being careful not to burn yourself.
 - ② Return the batteries to the store where you bought them or to a service center.If you do not, a fire may break out or you may burn yourself.

Please dispose of the used batteries properly and in accordance with local regulations.

■ Precautions when using the specialized RS-232C cable



Warning



- When using one of the connectors on the printer, do not touch the metal part of the other connector.



Precaution



- There is a danger of static electricity damaging the internal circuits of the product.
- Do not leave the cable wrapped around the product for a long time. If you do, there is danger of breakage and discoloration of the cable.

■ Precautions when using thermal paper (printing paper)



Precaution



- The darkness (density) of printing varies according to the type of printing paper used. The printing darkness (density) is adjusted either in the printer driver or using a software command. For details of this command, please refer to the Command Reference Manual available from your supplier.
- When using copy type printing paper, set two sheets of copy paper with either in the printer driver or using a software command. For details of this command, please refer to the Command Reference Manual available from your supplier.
- When using copy type printing paper, occasionally, the first or second sheet feeds incorrectly, blurring the printing. When this happens, start the printing over from the beginning.



Precaution



- When using thermal printing paper, take the following precautions. Thermal printing paper becomes discolored or degenerates, resulting in faint printing.
 - Do not put printed paper in bright light for a long period.
 - Avoid high temperature, humidity, fluids, and sunlight.
 - Do not use glue, adhesive, or adhesive tape containing a volatile organic solvent to retain printed thermal paper by applying it to ground paper.
 - When you want to retain the paper for a long time, we recommend that you either use deterioration-resistant type thermal paper or make a copy on a copier and retain the copy.
 - Do not keep the paper in contact with a PVC film etc. for a long time.
 - Avoid ammonia. Keep it away from paper copied on a copier that uses ammonia.
 - Do not let perspiration on your hands or oil touch the printed surface of thermal printing paper (surface to be printed or surface that has been printed).
 - When the thermal printing paper will be stored, store it in a dark place where the average temperature is 25°C or less and the humidity is 65% or less.
- Roll paper curls as it is ejected from the printer, so be careful to prevent it from entering the single sheet insertion opening.
- It may be impossible to assure the printing quality if the paper thickness is 80µm or more.

■ Precautions when installing the printing paper



Precaution



- Begin printing only after you have made sure that the printing paper is straight where it is ejected from the printing (thermal) head. If it is not straight, the paper will jam.
- To prevent the paper from being bent as it is fed into the printer, make sure that the front end of the paper is as shown below.

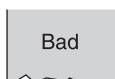

Accessories

Included Accessories

After opening the package, confirm that the printer and the following standard accessories have been included.

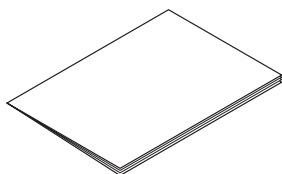

**User's Manual
(This Volume)**

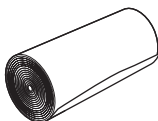

**Roll Paper
(φ30 mm x 10 m)**

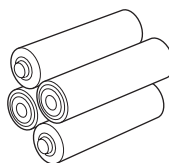

**Size AA
Alkaline Batteries (4)**

Optional Accessories

The following optional accessories are available for use with this printer. Purchase as needed.

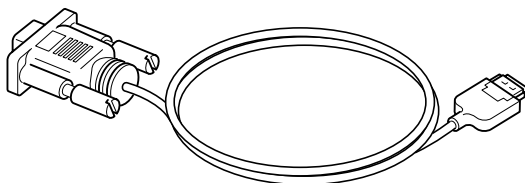

**RS-232C Cable (9-pin D-sub type connector)
(Part No. PD79901-0S)**

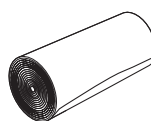

**Roll Paper
(φ30 mm x 10 m)**

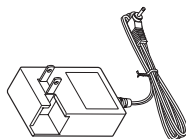

AC Adaptor

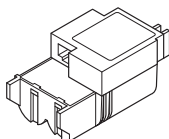

Battery Adaptor

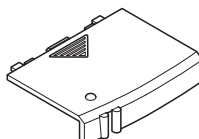

Battery Adaptor Cover

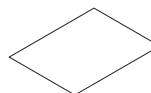

Installation Guide

**AC Adaptor Kit
(Part No. PD69957-0S)**

External Appearance and Part Descriptions

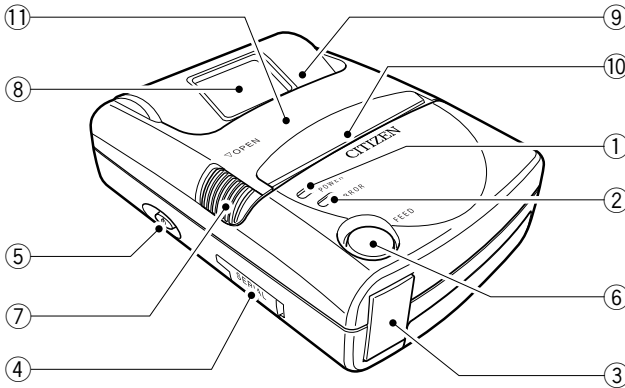

① POWER LED (POWER: Green)

The green indicator lights up when the power button () is pressed continuously for 2 to 3 seconds.

Additionally, the indicator blinks according to the printer mode (refer to the Error Indication Table). The indicator blinks more slowly when the batteries are running low. Replace the batteries when this occurs.

② ERROR LED (ERROR: Red)

The red indicator lights or blinks when the printer is unable to print because of the following conditions.

Type of Error	POWER LED (Green)	ERROR LED (Red)
Batteries running low	<input type="checkbox"/> ON <input checked="" type="checkbox"/> OFF	OFF
No paper (used up)	ON	○ ● ○ ● ○ ● ○ ●
Offline after paper loaded*1	ON	<input type="checkbox"/> ON <input checked="" type="checkbox"/> OFF
Printhead overheated	<input type="checkbox"/> ON <input checked="" type="checkbox"/> OFF <input type="checkbox"/> ON <input checked="" type="checkbox"/> OFF	<input type="checkbox"/> ON <input checked="" type="checkbox"/> OFF <input type="checkbox"/> ON <input checked="" type="checkbox"/> OFF
Paper feed motor overheated	ON	<input type="checkbox"/> ON <input checked="" type="checkbox"/> OFF <input type="checkbox"/> ON <input checked="" type="checkbox"/> OFF
Black mark (p. 17) not detected	<input type="checkbox"/> ON <input checked="" type="checkbox"/> OFF <input type="checkbox"/> ON <input checked="" type="checkbox"/> OFF	<input checked="" type="checkbox"/> OFF <input type="checkbox"/> ON <input checked="" type="checkbox"/> OFF <input type="checkbox"/> ON
Roll paper cover open	ON	<input type="checkbox"/> ON <input checked="" type="checkbox"/> OFF <input checked="" type="checkbox"/> OFF
Hardware error	OFF	ON

Time Axis  ○ ON, ● OFF

*1: Indicated only when the printer's internal "Offline status at reloading paper" setting (p. 29) is set to "Enable"

Error Indication Table

③ **Optical Receiver**

Receives printing data through infrared transmission.

④ **Serial Port**

Connect the optional RS-232C cable here when using the cable for printing.

⑤ **POWER Button()**

Turns the printer's power on and off.

To turn on the power, press this button continuously (2 to 3 seconds) until the power LED lights up.

⑥ **FEED Button (Paper Feed/Clear Error)**

The paper is fed while this button is held down. The feeder does not operate unless the paper is set in the printer.

⑦ **Cover Open Button**

Slide this button to open the cover. Close the cover after loading a roll paper.

⑧ **Paper Check Window**

Use to confirm that paper is loaded in the printer.

⑨ **Cut Sheet Insertion Slot**

Insert single sheets (cut sheets) of paper here.

⑩ **Paper Exit Slot/Paper Cutter**

The printed paper exits from the printer here. The slot includes a cutter (tear bar), which is used to cut the paper from the roll after printing.

⑪ **Roll Paper Cover**

Open the cover to load a roll paper. Close the cover after the paper is loaded.

Inside the Printer

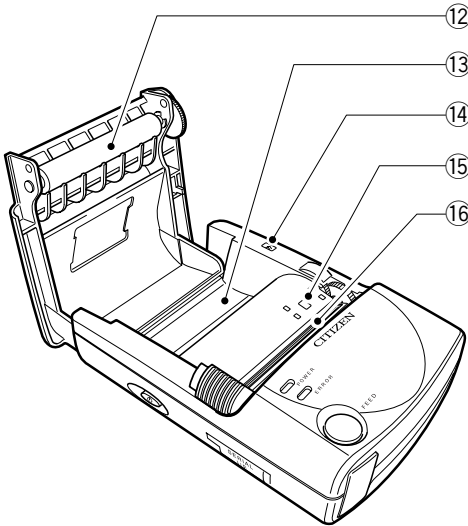

- ⑫ **Paper Feed Roller**
This feeds the paper to the paper exit slot.
- ⑬ **Paper Holder**
The roll paper is placed here.
- ⑭ **Cover Sensor**
Detects whether the roll paper cover is open or closed.
- ⑮ **Paper End/Black Mark Detector**
Detects whether or not paper is loaded.
 - **About the Black Mark**
This is a black marking that is pre-printed on the paper's print side. Once the black mark is detected, you can then feed the paper as needed with more accurate detection of the point where the paper is to be cut.
- ⑯ **Print Thermal Head**
This is the actual printing component.

Printer Underside

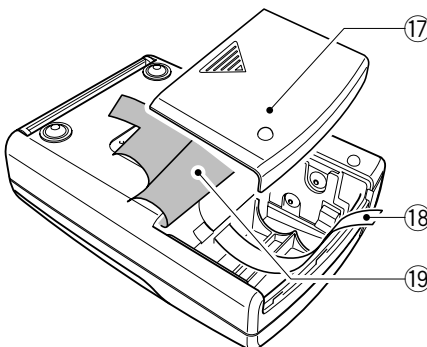

- ⑰ **Battery Cover**
Remove the cover to load the batteries (see p. 18).
- ⑱ **Battery Release Strip**
Pull it upwards to release the batteries.
- ⑲ **Battery Protective Sheet**
Protects surface of the batteries.

About the Power Source

The printer only runs on four AA rechargeable or dry cell batteries.

This section explains how the batteries are loaded and provides additional information about the batteries.

Loading the Batteries



Use These Batteries

- You can use the following batteries with this product. Use only four batteries of identical type.
 - AA rechargeable NiMH batteries (Recommended)
 - AA rechargeable NiCd batteries
 - AA alkaline batteries
- **Do not use any batteries other than those listed above.**
Use of batteries other than those specified may result in damage to the unit.
- The service life of AA alkaline batteries may be reduced according to the environment or the way they are used. In such cases, use AA rechargeable NiMH batteries or AA rechargeable NiCd batteries.



Precautions when using batteries

- Before loading dry cell batteries or rechargeable batteries in the printer, make sure that the covering of the battery has not been removed and is not scratched. And when removing and replacing rechargeable batteries, handle them very carefully so that you do not remove or scratch the covers of the batteries.
Be particularly careful when using the same batteries for a long time.
- Remove the batteries from the printer if you are not going to use it for a long time. If you do not, the batteries may leak.
- The electric power consumption of this printer varies greatly according to the printing type.
When batteries that have been stored for a long time or AA alkaline batteries that have been drained of energy are used, the printing may be too light or printer power may be cut off without any indication of a power reserve error (P. 15).
- The service life of AA alkaline batteries may be shortened depending on the manufacturer and utilization temperature (particularly low temperatures) and the amount of time that has passed since the batteries were manufactured.



About Battery Chargers

When using NiMH or NiCd batteries, be sure to obtain an appropriate charger that conforms to the specifications for the respective battery type.

Have on hand the four AA alkaline batteries provided with the printer.
(Follow the same sequence of steps when replacing the batteries.)

- 1 Slide the battery cover downwards to open the cover.**

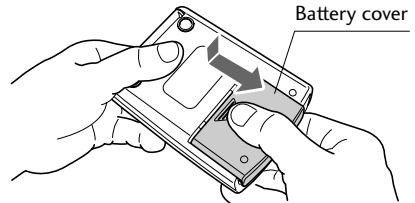

- 2 Raise the release part (green) of the battery protective sheet.**

* Do not vigorously pull up the battery protective sheet. It might break.

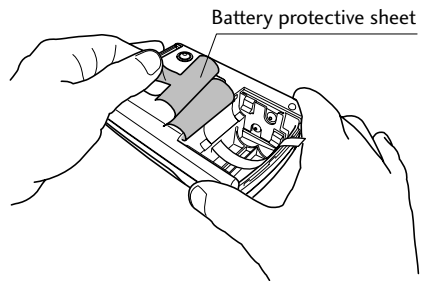

- 3 Set two batteries in the lower level according to the directions of the [+] and [-] symbols as shown in the figure.**

* Set each battery from the [+] side.

They cannot be inserted from the [-] side.

* Set the batteries in place one at a time.

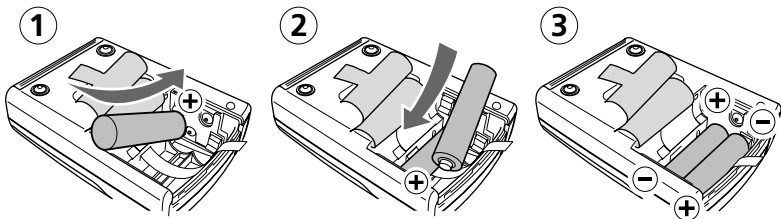

About the Power Source

- 4** Restore the battery protective sheet and set two batteries above the battery protective sheet according to the directions of the [+] and [-] symbols as shown in the figure.

* Set each battery from the [+] side. They cannot be inserted from the [-] side.

* Set the batteries in place one at a time.

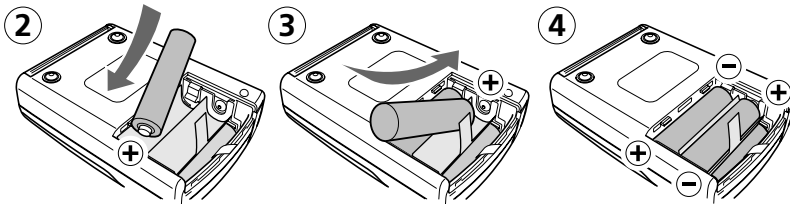

- 5** Slide the battery cover up again to close it.

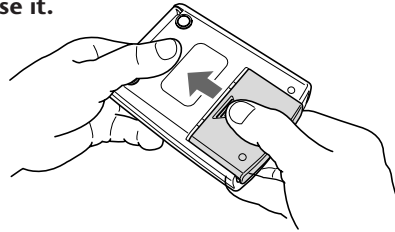

Unloading the batteries

First raise the release part (green) of the battery protective sheet, remove the two batteries from the top, then lift up the battery release lever (red) and remove the two batteries from the bottom.

* Do not vigorously pull up the battery protective sheet. It might break.

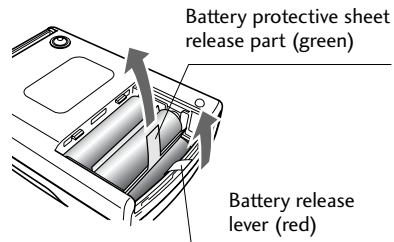

If the battery protective sheet has been removed, notify the store where you bought them or a service center. If you use the printer with the protective sheet removed, the batteries might short-circuit causing them to leak, overheat, or crack.

Turning the Power On and Off

Press the power button () continuously for 2 to 3 seconds to turn on the power.

- The green POWER LED lights.
- The red ERROR LED blinks rapidly if no paper is set in the printer.

Press the POWER button () again to turn off the power.

- The POWER LED goes off.

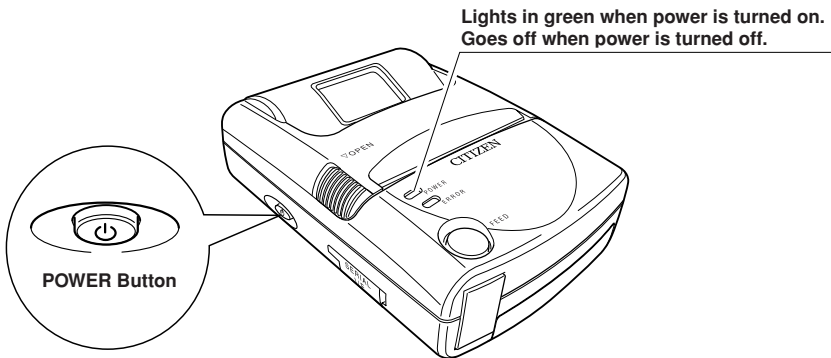

■ About the Auto Power Off Function

If the conditions listed below continue unchanged over a predetermined time period, the printer automatically shuts off to save battery power (this shutoff time is set at the factory at three minutes).

- No data received
- No operation with the FEED button (paper feed/clear error)

If the printer happens to be turned off with the Auto Power Off function, press the POWER button () to turn the printer on again.

Connecting the Printer

Data Reception Methods

The printer provides two interfaces for receiving print data and other information: the serial port and the infrared port (optical interface). The interface selection automatically switches according to whether or not the RS-232C cable is connected to the serial port. Data is transferred through the serial port only if the RS-232C cable is connected before the printer is turned on.

■ Connecting with the Infrared Port (Optical Interface)

1 Direct the printer's infrared port straight at the port of device to be linked.

- Transmission can be achieved within a 15° angle horizontally and vertically from center.
- Confirm that there are no obstacles in the space between the printer and the device to be connected. Data cannot be transmitted correctly if any obstructions are present in this space.

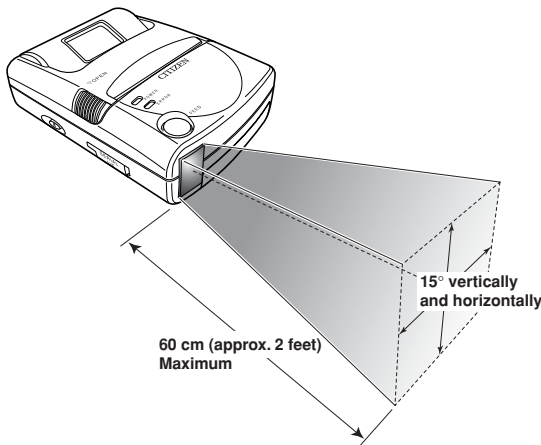

- Data may not be received correctly when transmitted in direct sunlight, under fluorescent lamps, and in other areas with strong light.
- Data may not be received correctly after the printer has been left for an extended period in temperatures outside the recommended storage temperature range.
- Transmission distance varies according to the device used and the surrounding conditions, so it may be impossible to establish a connection within the connection range provided in the specifications. There are devices that cannot be connected within 10 cm (0.33 feet) of the light receiver.
- A communication error may occur if it is used connected to another infrared device.

■ Connecting with the Serial Port (Cable)

First obtain the optional RS-232C cable (PD79901-0S).

- 1 Turn off the power to the printer and the device to be connected.**
- 2 Insert the cable connector straight into the printer's serial port.**
 - Take care not to connect it upside down. (The connector is connected with the side marked "PUSH" facing upwards). Forcing the connection may damage the unit.
 - To disconnect the connector, pull it out while pressing the part marked "PUSH".
- 3 Connect the other end of the cable to the serial port of the device being connected.**
- 4 Turn on the power to the printer and the connected device.**
 - Data is transferred through the serial port (through the RS-232C cable) only if the cable is connected before the printer is turned on.

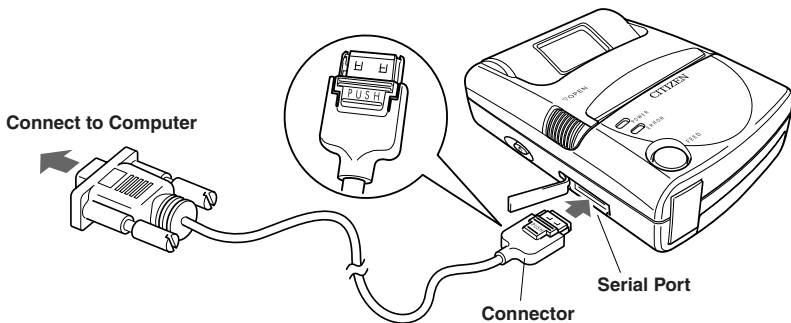

Precautions When Using the Connector Cable

- Ensure you are using the correct cable. For example, do not try to force a USB connector cable in this serial port.
- Do not touch the metal portion of the cable connector once the other end is connected to the printer port.
- Static electricity poses a risk of damage to the printer's internal circuitry.
- Do not leave the cable wrapped around the printer for extended periods. This may result in short circuiting and discoloration.

Loading the Paper

Loading Roll Paper

1 Turn on the printer.

- The ERROR LED blinks if no paper is set in the printer.

2 Slide the Cover Open button towards you to open the cover.

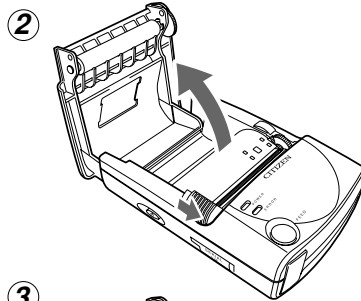

3 Place roll paper in the paper holder so that the end of the paper is extending toward you, as shown in the figure.

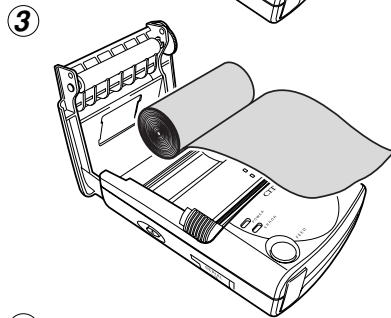

4 Move the cover towards you so that the end of the paper extends slightly from the paper exit slot.

- Close the cover after removing slack from the roll paper that you are using. Slackness may cause a paper jam.

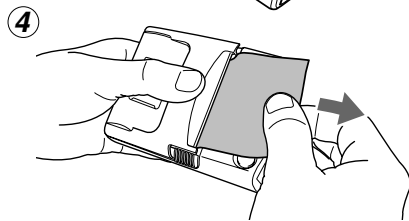

5 Firmly close the cover with both hands.

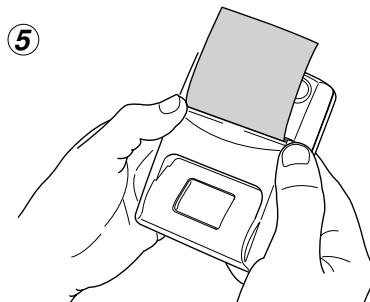

The paper is loaded automatically when the internal setting controlling the automatic paper feed is set to "ON."

Make sure the cover is fully and securely closed.

■ If the Paper is Not Loaded Straight

Slide the cover OPEN button to open the cover, then adjust the paper by hand. After confirming that the paper is completely straightened, securely close the cover.

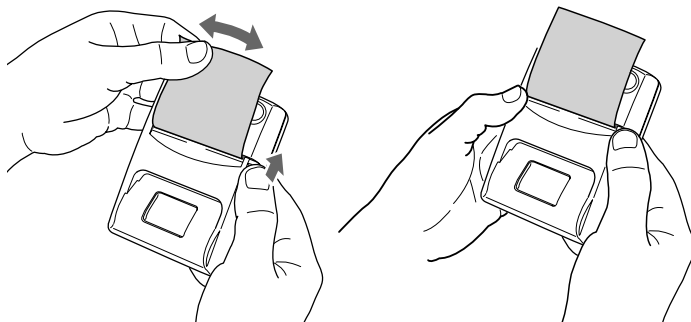

Do not allow the printed paper to enter the single sheet (cutsheet) insertion slot.

■ When Printing is Finished

When you have finished printing using the roll paper, slowly pull back the printed paper at an angle along the paper cutter, allowing you to cut it from the roll.

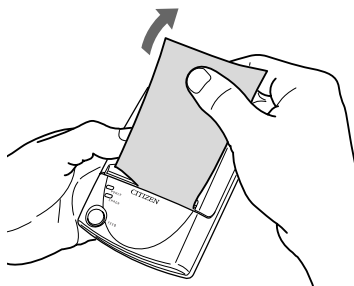

Do not touch the paper cutter. This may result in injury to your hand or whatever part of your body comes into contact with the cutter.

Feeding Single Sheets (Cutsheets)

1 Turn the printer on.

- Confirm that the roll paper cover is closed.
- The ERROR LED blinks if no paper is set in the printer.

2 Insert the paper as shown in the figure, by feeding the end of a single sheet into the single sheet insertion slot.

- The printer automatically takes up about 15 mm (0.6 inch) of the paper, the ERROR LED goes off, and the unit is ready for printing.

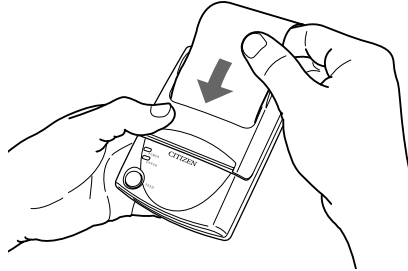

The paper is loaded automatically when the internal setting controlling the automatic paper feed is set to “ON.”

Make sure the cover is fully and securely closed.

■ Use of the following single (cut) sheet paper is recommended.

Normal thermal paper (1 sheet type): TF50KS-E2C (Nippon Seishi)

Copy thermal paper (2 sheet type): TLC#25 Black (Naigai Carbon Ink)

Special Labels: HW54S (Nippon Seishi)

Printing Test

You can conduct print tests to check the printer settings and confirm that the printer is operating correctly.

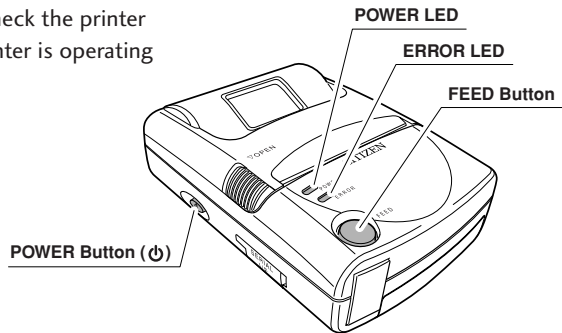

Self-Print Function

- 1** With the paper loaded, simultaneously hold down the **POWER** button (⏻) and **FEED** button.
- 2** When the **POWER LED** and the **ERROR LED** are blinking together, release the **POWER** button (⏻).
- 3** When the **POWER LED** and the **ERROR LED** begin to blink alternately, release the **FEED** button.
- 4** Press the **FEED** button to begin the self-print test.
 - To repeat the test, press the **FEED** button again after the previous test is completed.

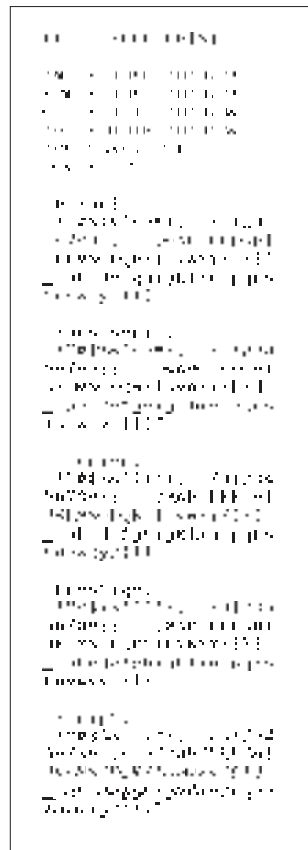

Hex Dump Function

The HEX dump function is used to judge whether or not the transmitted data is correct or not.

- 1 With the paper loaded, simultaneously hold down the POWER button (⏻) and FEED button.**
- 2 When the POWER LED and the ERROR LED are blinking together, release the POWER button (⏻).**
- 3 The POWER LED and the ERROR LED start blinking alternately, slowly at first. When the LED starts blinking faster, release the FEED button.**
- 4 Press the FEED button to execute the hex dump.**

```
--- HEX DUMP PRINT MODE ---  
31 32 33 34 35 36 37 38 12345678  
39 30 41 42 43 44 45 46 90ABCDEF  
47 48 49 4A 4B 4C 4D 4E GHIJKLMN  
4F 50 51 52 53 54 55 56 OPQRSTUVWXYZ
```

Internal Menu Settings List Print Function

- 1** With the paper loaded, simultaneously hold down the POWER button (⏻) and FEED button.
- 2** When the POWER LED and the ERROR LED are blinking together, release the POWER button (⏻).
- 3** The POWER LED and the ERROR LED alternately blink, slowly at first, then a little faster, then very fast; when they are flashing very fast, release the FEED button.
- 4** Press the FEED button to begin printing of the internal menu settings.
 - When the internal menu settings are printed out, the printer automatically turns off.

Note: The Internal Settings of the printer are usually pre-configured by the supplier for the particular application. These settings can be changed by software commands from a computer or using a special configuration utility under Windows. For further details of this, please contact your supplier or visit Citizen's web sites shown at the beginning of this manual.

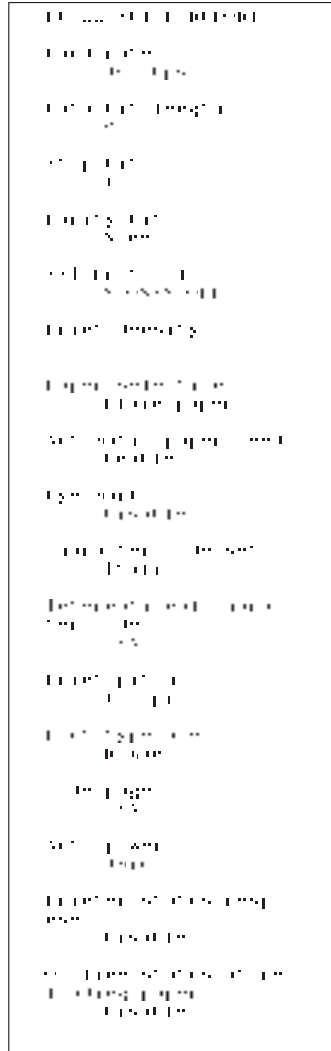

Care and Maintenance

If the paper becomes jammed inside the printer, or if some other such problem occurs, remove the paper and clean the printer's interior.

1 Turn off the printer.

2 Slide the cover OPEN button towards you to open the cover.

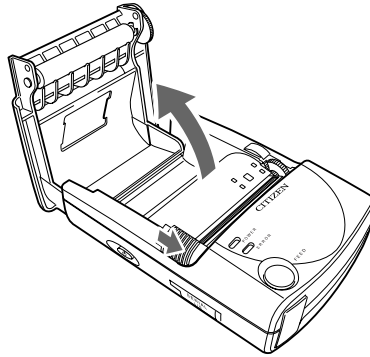

3 Use a cotton swab or other such soft object to wipe any grime and paper dust from the feed roller and print (thermal) head.

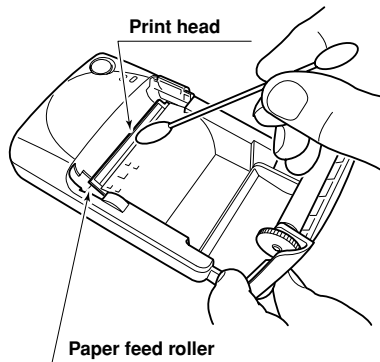
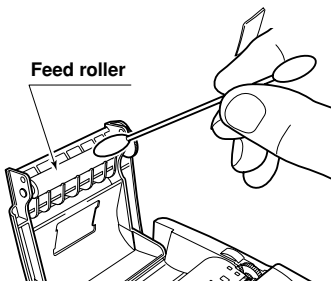

- Never bring any hard object in contact with the head. This may result in damage to the unit.
- The print head becomes very hot. Allow the printer to rest for a short to protect yourself from burns.
- If any foreign object gets inside the head or the paper feed gear, it may cause a malfunction.
- Dropping the printer may cause a malfunction. Handle it very carefully.

Troubleshooting

No malfunction may be indicated in the following situations. Check these points before considering malfunction as the cause of your problem.

Problem	Cause	Solution
Printer not operating	<ul style="list-style-type: none">• Printer is not turned on.• Battery “+” and “-” terminals are reversed.• Batteries are running low. • Rechargeable batteries are not sufficiently charged.	<ul style="list-style-type: none">• Press the POWER button (ϕ).• Install the batteries so that they are in the proper direction.• Replace all batteries with fresh batteries.• If using rechargeable batteries, fully charge the batteries.• Change the batteries again.
Paper cannot feed	<ul style="list-style-type: none">• A foreign object is caught on the gear.	<ul style="list-style-type: none">• Remove the foreign object.
Error results when executing print command	<ul style="list-style-type: none">• Printer is not properly connected to other device with cable. • Printer is not turned on.• Paper is jammed in the printer.	<ul style="list-style-type: none">• Make sure the printer and the device issuing print commands are connected correctly with the RS-232C cable, then turn on the power to the printer.• Turn on the power.• Open the paper roll cover and remove the jammed paper or other obstruction.
Cannot print using infrared transmission	<ul style="list-style-type: none">• Devices are either too close together or too far apart. • Infrared ports are not on axis.	<ul style="list-style-type: none">• Adjust the distance between the two devices so that they are in the range given in the specifications (p. 22).• Align both ports so that they are directly facing each other.

Note: The service life of AA alkaline batteries may be reduced according to the environment or the way they are used. In such cases, use AA rechargeable NiMH batteries or AA rechargeable NiCd batteries.

Optional AC Adaptor Kit

Installing the Battery Adaptor

- 1** Remove the battery cover from the printer.
(Remove batteries if there are any loaded.)
- 2** Push in the battery adaptor as shown in the figure.
- 3** Connect the AC adaptor cord.
- 4** Attach the battery adaptor cover.

Notes:

- This kit is for use with this printer only. You cannot use it with other products.
- Be sure to insert the battery adaptor before connecting the AC adaptor.
- When the AC adaptor is connected, there is voltage at the battery adaptor's terminals.
Do not create a short between the two terminals.
- When using batteries, be sure to use the original battery cover.

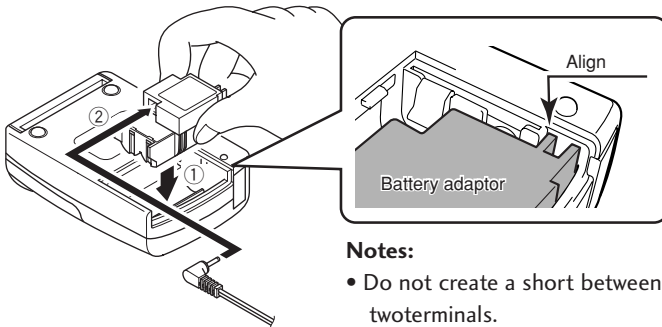

Notes:

- Do not create a short between the two terminals.
- Be careful not to insert incorrectly.

Specifications

Category	Specification
Printing Method	Direct Thermal
Print Speed	<p>Normal thermal paper (1 sheet type): 300 dotlines/second (maximum) (64 dots/line or less)</p> <ul style="list-style-type: none"> Print speed with batteries fully charged and printer set to fast printing <p>Copy thermal paper (2 sheet type): 100 dotlines/second (64 dots/line or less)</p> <ul style="list-style-type: none"> Print speed with batteries fully charged and printer set to fast printing
Printhead	<p>Total Dot Count: 384 dots/dotline</p> <p>Dot Pitch: 8 dots/mm</p> <p>Print Width: 48 mm (1.89 in.)</p> <p>Head Life: 50 million pulses (12.5% print ratio, normal temperature, rated energy)</p> <p>But not if the head has been damaged by a foreign object.</p> <p>Durability: Recommended designated paper.</p> <p>30 km (32808 yd.) or greater (w/specified paper).</p> <p>10 km (10936 yd.) or greater (transfer paper: original + one sheet)</p>
Print Direction	<p>Portrait: Normal print mode (printing while receiving data)</p> <p>Page mode: Printing after reception of data for one page</p> <p>Landscape: In page mode only</p>
Emulations	Conforms to ESC/P commands, barcode commands (ESC/POS compatible)
Fonts	Roman, Sans serif, Courier, Prestige, Script
Character codes	<p>ASCII 96 Normal Characters</p> <p>International Characters: 16 Languages +1 Legal Character set</p> <p>IBM Characters and Graphics</p> <p>Code page: USA, MULTILINGUAL, PORTUGAL, FRENCH-CANADA, NORWAY, SCANDINAVIA, YUASCII, LATIN 2, CYRILLIC, RUSSIAN, HUNGARIAN, KAMENICKY, TURKEY, ICELANDIC, WELSH, MAZOVIA, UKRAINIAN, NEW HEBREW, OLD HEBREW, DEC HEBREW, GREEK 437, GREEK 851, GREEK ABC, GREEK ELOT 928, CYPRUS, MALTA, ARABIC NLS, ARABIC EXT, UNISYS, BRAZIL ASCII, BRAZIL ABICOMP, LATIN 1</p> <p>Windows Page: US ANSI, CYRILLIC, ANSI, EAST EUROPEAN ANSI</p>

Category	Specification
Print Columns	21 columns (10 CPI), 25 columns (12 CPI), 32 columns (15 CPI), 36 columns (17 CPI)
Character Font Dot Matrix Sizes	18 H x 24 V (10 CPI), 15 H x 24 V (12 CPI), 12 H x 24 V (15 CPI), 10.5 H x 24 V (17 CPI)
Barcodes	UPC-A, UPC-E, JAN13(EAN), JAN8(EAN), ITF, CODABAR, CODE39, CODE128
Print Paper 1) Paper Feed Method 2) Media Width 3) Paper Path 4) Media Types 5) Recommended Papers	Friction Feed 58 ₋₁ ⁰ mm (2.28 _{-0.04} ⁰ in.) Rear (Clamshell) Single Sheet (Cut Sheet)/ Continuous 1-sheet or copy paper (original + 1 sheet) (only folded paper supported for continuous transfer paper) 1-sheet Paper: TF50KS-E2C (Nippon Seishi) Copy Paper: TLC#25 Black (Naigai Carbon Ink) Special Labels: HW54S (Nippon Seishi) • Paper Roll Diameter: Maximum outer diameter $\phi 30$ mm ($\phi 1.18$ in.) Minimum diameter for starting roll $\phi 8$ mm ($\phi 0.32$ in.) * Do not fold back or apply adhesives to paper rolls ends
Interfaces	Optical Interface <IrDA 1.0> Serial Port <RS-232C> Special Cable (optional)
IrDA Interface	Transfer Rate: 115200 bps (maximum)
Serial Port	Transfer Rates: 4800, 9600, 19200, 38400, 57600, 115200 bps Parity: Even, Odd, No Data Length: 7- or 8-bit Stop bit: 1- or 2-bit
IR Transfer Range	Figures apply with printer and computer ports on-axis and directly facing each other, with the computer IR port within a vertical and horizontal angle $\pm 15^\circ$ from center IrDA: Maximum 60 cm (approx. 2 ft.) (may vary according to the computer and environmental conditions; see p. 22)
Input Buffer Size	64 KB
LED Color	POWER LED: Green ERROR LED: Red

Category	Specification
Power Source	4 x AA cells (Rechargeable NiMH/Rechargeable NiCd/Alkaline) Supply Voltage Rechargeable NiMH: 4.8 V DC NiCd: 4.8 V DC Dry Cell Alkaline: 6.0 V DC
Power Check Functions	Auto Power Off, Low Power Detect
Printable Lines	Approximately 14000 Lines (with rechargeable NiMH batteries) Count for the print of slide patterns at 25°C (77°F), with unused AA rechargeable NiMH batteries loaded and print density set to 0; the number of lines that can be printed continuously varies according to the manufacturer of the batteries, the utilization temperature, and the amount of time that has passed since the batteries were manufactured. The above numbers of lines are criterion that cannot be assured.
Environmental Conditions	Warranted Operating Temperature: 0°C (32°F) to +45°C (113°F) (with rechargeable NiMH/rechargeable NiCd batteries) Warranted Print Temperature: 5°C (41°F) to +40°C (104°F) (with rechargeable NiMH/NiCd batteries) Storage Temperature: -20°C (-4°F) to +60°C (140°F) Operational Humidity: 30% to 90% RH (no condensation) Storage Humidity: 30% to 90% RH (no condensation)
Applicable Standard	FCC Part 15B, Class B/EN55022/EN55024/ EN61000-3-2/EN61000-3-3
Power Consumption	7 W (with rechargeable NiMH/NiCd batteries), 8 W (with alkaline batteries)
Dimensions	77.4 mm (W) x 108.3 mm (D) x 35.4 mm (H) (3.05 in. (W) x 4.26 in. (D) x 1.39 in. (H))
Weight	Printer (including four AA alkaline batteries) 215 g (0.474 lb.) or less
Included Accessories	User's Manual, Size AA Alkaline Batteries (4), 30 mm (1.18 in.) diameter Roll Paper (length approximately 10 m (32.8 ft.))
Optional Accessories	RS-232C cable (9-pin D-sub type connector/Part No. PD79901-0S), Roll Paper, AC Adaptor Kit (Part No. PD69957-0S)

INFORMATION

Information for Users on Collection and Disposal of used Batteries.

The symbol in this information sheet means that used batteries should not be mixed with general household waste.

For proper treatment, recovery and recycling of used batteries, please take them to applicable collection points.

For more information about collection and recycling of batteries, please contact your local municipality, your waste disposal service or the point of sale where you purchased the items.



Information on Disposal in other Countries outside the European Union.

This symbol is only valid in the European Union.

If you wish to discard used batteries, please contact your local authorities or dealer and ask for the correct method of disposal.

WEEE MARK

En

If you want to dispose this product, do not mix with general household waste. There is a separate collection systems for used electronics products in accordance with legislation under the WEEE Directive (Directive 2002/96/EC) and is effective only within European Union.

Ge

Wenn Sie dieses Produkt entsorgen wollen, dann tun Sie dies bitte nicht zusammen mit dem Haushaltsmüll. Es gibt im Rahmen der WEEE-Direktive innerhalb der Europäischen Union (Direktive 2002/96/EC) gesetzliche Bestimmungen für separate Sammelsysteme für gebrauchte elektronische Geräte und Produkte.

Fr

Si vous souhaitez vous débarrasser de cet appareil, ne le mettez pas à la poubelle avec vos ordures ménagères. Il existe un système de récupération distinct pour les vieux appareils électroniques conformément à la législation WEEE sur le recyclage des déchets des équipements électriques et électroniques (Directive 2002/96/EC) qui est uniquement valable dans les pays de l'Union européenne.

Les appareils et les machines électriques et électroniques contiennent souvent des matières dangereuses pour l'homme et l'environnement si vous les utilisez et vous vous en débarrassez de façon inappropriée.

Sp

Si desea deshacerse de este producto, no lo mezcle con residuos domésticos de carácter general. Existe un sistema de recogida selectiva de aparatos electrónicos usados, según establece la legislación prevista por la Directiva 2002/96/CE sobre residuos de aparatos eléctricos y electrónicos (RAEE), vigente únicamente en la Unión Europea.

It

Se desiderate gettare via questo prodotto, non mescolatelo ai rifiuti generici di casa. Esiste un sistema di raccolta separato per i prodotti elettronici usati in conformità alla legislazione RAEE (Direttiva 2002/96/CE), valida solo all'interno dell'Unione Europea.

Du

Deponer dit product niet bij het gewone huishoudelijk afval wanneer u het wilt verwijderen. Er bestaat ingevolge de WEEE-richtlijn (Richtlijn 2002/96/EG) een speciaal wettelijk voorgeschreven verzamelstelsel voor gebruikte elektronische producten, welk alleen geldt binnen de Europese Unie.

Da

Hvis du vil skille dig af med dette produkt, må du ikke smide det ud sammen med dit almindelige husholdningsaffald. Der findes et separat indsamlingsystem for udfjente elektroniske produkter i overensstemmelse med lovgivningen under WEEE-direktivet (direktiv 2002/96/EC), som kun er gældende i den Europæiske Union.

Por

Se quiser deitar fora este produto, não o misture com o lixo comum. De acordo com a legislação que decorre da Directiva REEE – Resíduos de Equipamentos Eléctricos e Electrónicos (2002/96/CE), existe um sistema de recolha separado para os equipamentos electrónicos fora de uso, em vigor apenas na União Europeia.

Pol

Jeżeli zamierzasz pozbyć się tego produktu, nie wyrzucaj go razem ze zwykłymi domowymi odpadkami. Według dyrektywy WEEE (Dyrektywa 2002/96/EC) obowiązującej w Unii Europejskiej dla używanych produktów elektronicznych należy stosować oddzielne sposoby utylizacji.



Citizen Systems America Corporation

<http://www.citizen-systems.com>

363 Van Ness Way, Suite 404

Torrance, CA 90501. USA

Tel: (310) 781-1460

Citizen Systems Europe GmbH

<http://www.citizen-europe.com>

Mettinger Strasse 11

D-73728, Esslingen

Germany

Tel: +49 (0) 711 3906 420

Park House, 643-651 Staines Road

Feltham, Middlesex, TW14 8PA

United Kingdom

Tel: +44 (0) 20 8893 1900

Citizen Systems Japan Co., Ltd.

<http://www.citizen-systems.co.jp>

6-1-12, Tanashi-cho, Nishi-Tokyo-shi

Tokyo, 188-8511. Japan

Tel: +81 (0) 424 68 4608