

SC800/ SC1600

8 Zone & 16 Zone Downloadable Panels

Installation & Programming Manual

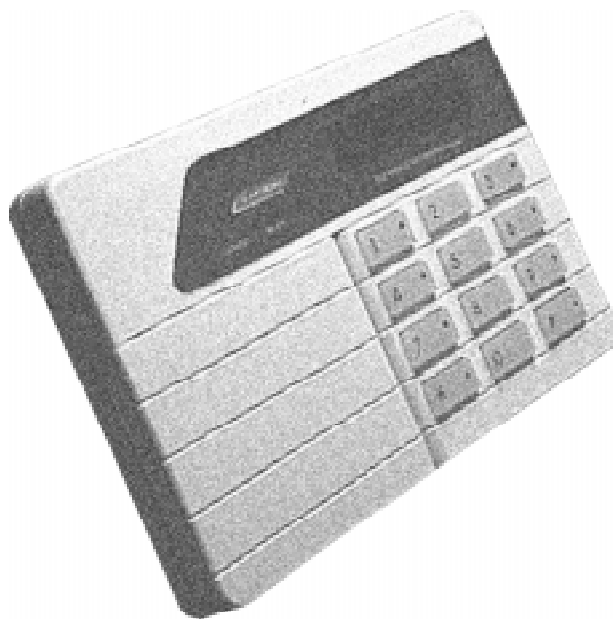

**Use with
EKP1 LED or SK1L LCD keypad**

**Programmed through the LCD keypad
or with the ScanPro Downloader Software**

ARROWHEAD
A PRODUCT OF SENTROL, INC.

USER CODE SPECIAL FUNCTIONS

Zone 1-9 Bypass	[PPPP] + [ZZZZ] + [#]	
Zone 10-16 Bypass	[PPPP] + [1&2] + [Z] + [1&2] + [Z] + [#]	
Internal Group 1 Bypass	[PPPP] + [*] + [1] + [#]	
Internal Group 2 Bypass	[PPPP] + [*] + [2] + [#]	
Bypass Both Groups	[PPPP] + [*] + [1] + [*] + [2] + [#]	
Instant Mode Arm	[PPPP] + [*] + [0] + [#]	
Duress Code	[PPPP] + [0] + [#]	
Set Time/Date	[PPPP] + [*] + [3] + [#]	EKP1
Test Mode On	[PPPP] + [*] + [4] + [#]	
Fault Analysis Mode	[PPPP] + [*] + [9] + [#]	
System Directory Request	[PPPP] + [*] + [6] + [#]	EKP1
Extend Closing Window 15 mins.	[PPPP] + [*] + [5] + [#]	
Turn Chime Mode On	[PPPP] + [*] + [1&2] + [3] + [0] + [#]	
Turn Chime Mode Off	[PPPP] + [*] + [1&2] + [3] + [1] + [#]	
Print Event History	[PPPP] + [*] + [1&2] + [3] + [2] + [#]	
Keypad Activated Switch On	[PPPP] + [*] + [1&2] + [4] + [0] + [#]	
Keypad Activated Switch Off	[PPPP] + [*] + [1&2] + [4] + [1] + [#]	
Timer Switch Toggle	[PPPP] + [*] + [1&2] + [4] + [2] + [#]	
View History Mode	[PPPP] + [*] + [1&2] + [6] + [8] + [#]	EKP1
Users Menu	[PPPP] + [] (Key Under Door)	EKP1

[PPPP] = Users Pass Code

[ZZZZ] = Zone(s)

INSTALLER CODE SPECIAL FUNCTIONS

Clear Event History	[*&0] + [I I I I] + [*] + [1&2] + [5] + [2] + [#]	EKP1
Installers Menu	[*&0] + [I I I I] + [] (Key Under Door)	EKP1
Enter Keypad Programming for Keypad Addressing	[*&0] + [I I I I] + [9]	
Clear ScanPro Generated Message from Keypad	[*&0] + [I I I I] + [*] + [1&2] + [5] + [0] + [#]	EKP1

[I I I I] = Installer Code [*] = Mode Key [1&2] or [*&0] = Keys Pressed Simultaneously

~~EKP1~~ = *These commands are Non-Functional when used from the EKP1 LED keypad.*

HARDWARE FEATURES

- ◆ 8 or 16 Hardwire EOL Resistor Supervised Zones
- ◆ Keypad Programmable w/ SK1L keypad
- ◆ 3 wire keypad with snap fit design
- ◆ Provisions for earth grounding
- ◆ Two keypads available (LCD, LED)
- ◆ Single/dual bell operation
- ◆ Keypad resettable smoke power
- ◆ Remote/Local prewarning output
- ◆ Courtesy output to drive loop interface modules
- ◆ Keyswitch operation
- ◆ Built-in communicator
- ◆ Remote ready and arm LEDs
- ◆ Terminal type wire connections
- ◆ Planar gap lightning protection
- ◆ Ring detector with special "detect" circuitry that bypasses answering machines
- ◆ Assignable relay output used for door strike, strobe, etc.
- ◆ Data output board available for derived channel, RF interfaces, etc.
- ◆ Triple element gas discharge tube lightning protection

SOFTWARE FEATURES

- ◆ 30 user codes available with open/close by user option
- ◆ 3 telephone numbers with Independent account numbers for split reporting and backup reporting
- ◆ Single user, multipremise and partitioned areas of operation (up to 4 full partitions)
- ◆ Ten reporting formats available
- ◆ Open/Closing reports by exception. Exception schedule includes 10 holidays
- ◆ Programmable zone response times
- ◆ Four separate entry/exit timers available
- ◆ Incrementing account numbers for partitioning
- ◆ Printer Output is available for Real Time History printing and/or Full History Dumps with On-Site printer
- ◆ Selective Open/Close reporting by Partitions
- ◆ Fail to Communicate disable is available
- ◆ Optional Bell shutoff from any partition keypad
- ◆ View History command is available for the User
- ◆ Common E/E zones configurable in partitioning
- ◆ Ringback available at the keypad
- ◆ ***New Features with Micro P/N 118-875417***
- ◆ *Option for AutoArming at preselected daily time with Force Arm signal generated to identify "still-violated" zones*
- ◆ *Conditional Opening Signal for "Disarm After Alarm"*
- ◆ *"Real-Time" restoral reporting*

INTRODUCTION

The SC800/1600 of alarm systems represent the latest technological advances available in the security industry. The system has been designed to meet or exceed requirements for residential and most commercial installations.

The SC800/1600 system consists of an uploadable/downloadable, eight or sixteen zone control panel/communicator with choice of multiple language LCD or individual LED keypads. Each installation can be "custom tailored" by programming the Electrically Erasable Programmable Read Only Memory (EEPROM) supplied with the system. Programming is accomplished using the SK1L keypad, or the system can be set up using ScanPro Downloader uploading/downloading software.

TABLE OF CONTENTS

SECTION 2: INSTALLATION INSTRUCTIONS	6
SECTION 4: SYSTEM KEYPADS OVERVIEW	11
SECTION 5: USER/INSTALLER MENUS	13
SECTION 6: PROGRAMMING INSTRUCTIONS.....	16
SECTION 7: SPECIAL PANEL FEATURES	18
SECTION 8: PROGRAMMING ITEM DESCRIPTION	25
SECTION 9: UL COMPLIANCE	33
SECTION 10: COMPLIANCE	34
SECTION 11: CANADIAN INSTALLATIONS.....	35
SECTION 13: SPECIFICATIONS.....	37
INDEX	38
HARDWARE FEATURES	45
INTRODUCTION	45

SECTION 1: SYSTEM OVERVIEW & AVAILABLE OPTIONS

1.1 GENERAL DESCRIPTION

The SC system is ready to use from the factory. It is shipped from the factory with a default (factory) program. The factory programming for model SC 800 consists of one (1) fire zone and seven (7) burglary zones. For model SC1600 the factory programming consists of two (2) fire zones and fourteen (14) burglary zones. The zone configuration can be individually reprogrammed from the SK1L keypad or by using the ScanPro Downloader Software to suit whatever zone options are necessary. Programming **cannot** be performed with the **EKP1** LED Keypad. User 16 may be additionally programmed for keyswitch operation. There are four (4) individual timers for E/E delay zones. Programmed loop response is available from 10 milliseconds to 500 milliseconds.

The built in digital communicator can be programmed for today's most popular reporting formats.

See programming worksheet for Factory Default details.

1.2 ZONE PROGRAMMING OPTIONS

ZONE FUNCTIONS	ZONE AVAILABLE	SUB FUNCTION TYPE
BURGLARY	E/E 1	Bypass zone
	E/E 2	Chime zone
	E/E 3	Day/Night trouble
	E/E 4	Loop response time Swinger rejection
	Instant	Swinger rejection
FIRE	Interior 1	
	Interior 2	
	Follower	
24 HOUR	Audible	Loop response time Swinger rejection Trouble
	Silent Audible	Bypassable Loop response time Swinger rejection Trouble

1.4 TIMER OPTIONS

The SC system has various timer options that can be changed to meet your various system needs. Listed below are the programmable range for each timer option.

Bell shutoff time	2 - 30 minutes	Zone reporting delay time	10-150 seconds
Zone response time	10mSecs to 500mSecs	AC and Low battery reporting delay time	1-15 minutes
Test timer A	Daily weekly monthly yearly reporting	Entrance delay groups 1 through 4	10-150 seconds
Test timer B	Daily weekly monthly yearly reporting	Exit delay groups 1 through 4	10-150 seconds
Exception windows	15 min. - 225 minutes	Opening exception window start	1 min. - 24 hours
Holiday schedule	1 - 10 holidays by month/day	Closing exception window start	1 min. - 24 hours
Switched Output	0 - 23.75 hours	Open/Close exception schedule	1-7 days

1.3 HARDWARE OPTIONAL ITEMS

EKP1 - This is an LED keypad that can be used in the SC800 system. It is capable of showing zone status for only zones 1-8. It is capable of many of the normal operations but **not** able to function as a keypad programmer. The operations that are **NOT** usable with this keypad are also indicated on page (i).

SK1L - This is an LCD keypad that can be used in the SC800 and the SC1600 systems. It has **full** capabilities for operating and programming the systems it is attached to. A variety of International versions of this keypad are also available that have User/Installer messages in different languages.

Four of any combinations of the keypads are the maximum per installation.

DOB - This is the **Data Output Board**. It can be used as any of five output devices. These range from Zone Alarm memory devices to a printer interface, to a Status Output device, to a Bell Module. The latter three are explained in detail in the programming detail for Item 30.

POB-1 - The POB-1 kit can also be used to interface an on-site parallel printer to the SC800/1600 alarm control panels. It consists of a PCB and Interface cable along with mounting hardware. The PCB must be used in the stack as specified in the instructions.

LC1 - This is the Telephone Line cut module. It is designed to sense for a drop in voltage below 3 volts for a time period of 30 seconds +/- 15 seconds. Once activated it turns on a Form "C" relay that can be used for a local bell, piezo or even a wireless transmitter to transmit to a neighbor or radio communicator in case of telephone line loss.

FM2000 - This is a Two Wire smoke detector module. The SC system was originally designed to accommodate four wire smoke detectors. A maximum of ten, Two wire smoke detectors can be attached to one of the FM2000 units. It comes with a 4.7K resistor that must be used as the End-Of-Line resistor.

SECTION 2: INSTALLATION INSTRUCTIONS

- CAUTION -

1. Do not connect battery until installation is complete.

2. Do not apply power until after Step 13.

3. Reversing battery leads will result in permanent damage to the unit and will void the warranty.

1. Mount control panel in a convenient location.
2. Mount EKP1 or SK1L Keypad. The EKP1 keypad may be either surface mounted or flush mounted into a double gang box. The EKP1 and SK1L keypads may also be mounted directly onto the wall using appropriate hardware (not supplied).
3. For single bell operation, connect a 12.5 V Bell or Siren to terminals 7(-) and 9(+). Observe polarity. Output is steady for burglary, pulsed for fire.
4. For dual bell operation, connect a 12.5 V Bell or Siren to terminals 7(-) and 8(+) and a 12.5 V Fire Bell or Siren to terminals 7(-) and 9(+). Observe polarity. Make sure EEPROM memory location 33 is programmed for dual bell operation.
5. Unswitched 12.5 V is available at terminals 3(-) and 4(+) for auxiliary devices.
6. If a smoke detector is used, its 12.5 V power should be supplied through terminal 10(+ 12.5 V) with its negative lead connected to terminal 11 (smoke-). This 12.5V source will be interrupted for approximately 5 seconds during smoke reset.

The smoke detector output may be manually reset by simultaneously pressing keys 1 & 3 when a "7" is selected in Memory Location 30 section 2. A 1 or 5 must not be programmed in Location 29.
7. Connect the input zones to the terminals located on BS3 and BS4 (if EEM-8 is installed). Make sure to use the supplied END OF LINE resistors as shown in Figure 1. The SC800/1600 panels can be programmed to not use end of line resistors (if required). This is done in location 30, section 1. Closed circuit loops are wired in series with the resistor, open circuit loops are wired parallel to the resistor. All Fire zones require the use of the 2.2K EOL resistors.

Note: UL Fire Installations require use of EOL2200 resistors (not supplied).
8. If keyswitch operation is used, connect a UL listed Momentary normally open switch between terminals 19 (-) and 3 or 4(+).
9. Connect the F.C.C. approved telephone connection cable to terminals 20, 22, 23, and 24 as shown in Figure 1. Insulate all unused leads. **THE CABLE MUST BE PHYSICALLY SEPARATED FROM POWER AND SIGNAL LINES.**
10. Connect EKP1 or SK1L to control. Red lead to terminal 16. Black lead to terminal 17. Yellow lead to terminal 18. *Refer to the EKP1 or SK1L Installation Manual for complete instructions regarding installation and options. WIRES CONNECTING EKP1 or SK1L to CONTROL MUST BE KEPT AWAY FROM A.C. AND TELCO WIRING TO MINIMIZE TRANSIENT PROBLEMS. There can be no more than four keypads per panel. Current draw for the EKP1 and SK1L keypads is 100mA each. Homerun all keypad cables. The maximum length of a cable run to a keypad is 300 feet based on 22 gauge wire.*
11. Connect Terminal 21 and Cabinet to an EARTH GROUND.

NOTE:
1) Suggested earth ground and protection levels are:
a) Preferred protection - Separate metal grounding rod.
b) Acceptable Protection - Metal cold water pipe.

2) Use at least 16 gauge wire between terminal 21 and earth ground.

3) Keep wire run as short as possible and away from other panel wiring.

4) Do not use an existing lightning rod ground; it can provide a path for lightning strikes to panel.
12. Check all connections, verifying polarity.
13. Connect the transformer to terminals 1 and 2. Use 18 gage wire to connect the transformer to the control panel. Polarity is not important.
14. Plug the transformer into an unswitched 120 Vac receptacle. The indicators on the keypad should light.
15. Connect the BLACK FLYING LEAD to the negative (-) terminal of a 12-volt, rechargeable gel-type battery. Connect the RED FLYING LEAD to the positive (+) terminal of the battery. **NOTE: A reverse battery connection will blow the factory replaceable Fuse and will void the warranty.** If the battery is not fully charged, allow 36 hours for battery to fully charge.
16. Plug the telephone connection cable into an RJ31-X jack which meets the mechanical tolerance and plating requirements specified in subpart F of FCC part 68.

Note: The Instructions and drawing shown in Figure 1 below are used when a large AH battery with screw terminals is used with the SC1600 control panel. The Tongue connectors are shipped with the SC1600 panel only.

1. Cut off Faston Connector.
2. Strip off insulation to expose 1/4" lead.
3. Crimp Ring Tongue connector on wire. Test by pulling firmly on connector.

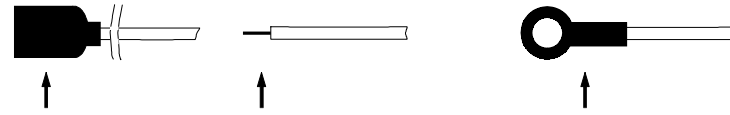

Figure 1 - Battery Connector Modification for large AH Batteries

WIRING DIAGRAM FOR THE SC800/1600

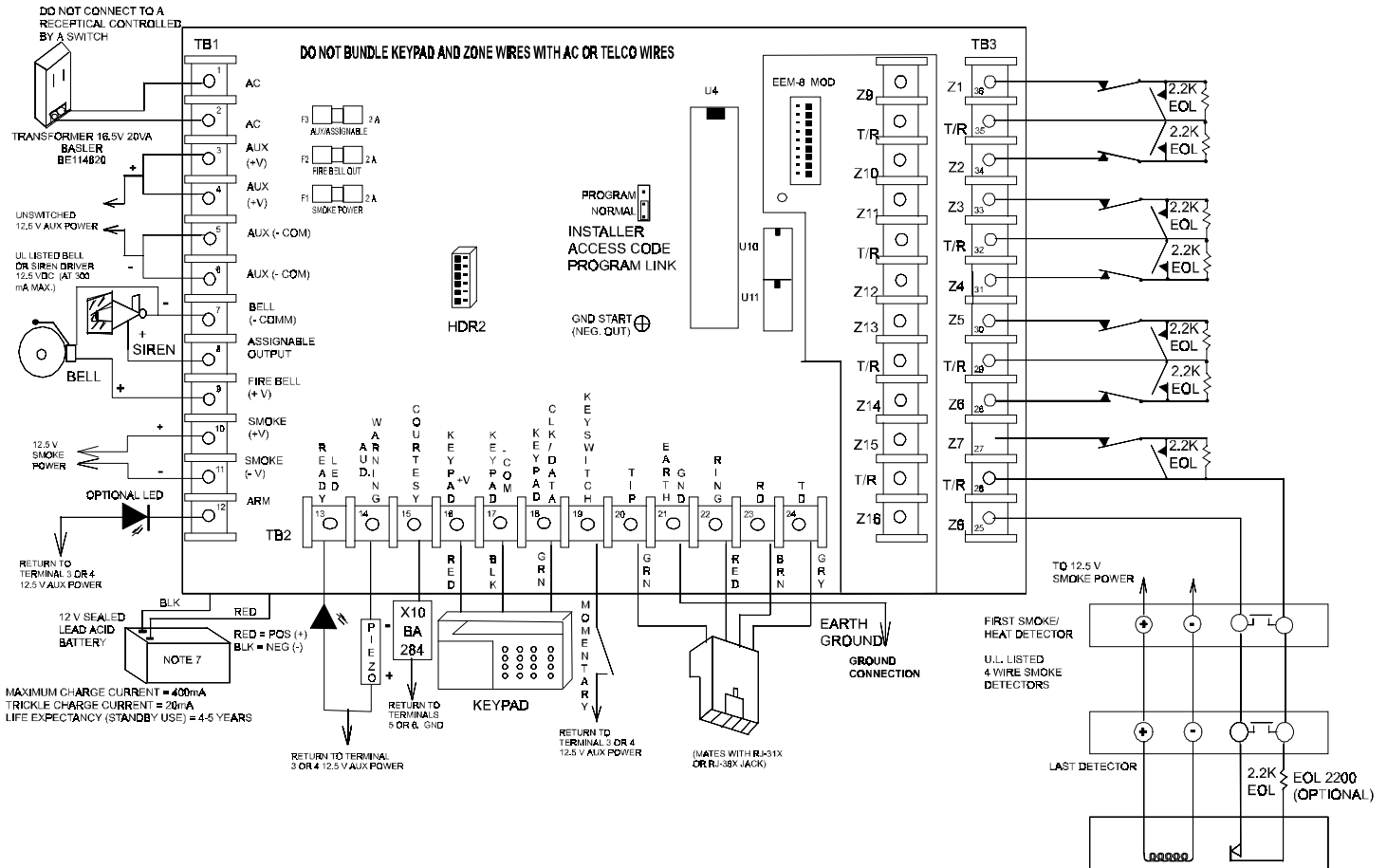

Figure 2 - SC800/SC1600 Wiring Diagram

2.1 TERMINAL DESCRIPTIONS

2.1.1 AC TRANSFORMER TERMINALS 1 & 2

The system is powered with a 16.5V 20VA "non-fused" UL listed class II transformer. The AC transformer is connected to terminal 1 and 2. It is recommended that the AC transformer be connected with a minimum of 18 gauge wire at a distance of no more than 50 feet. The AC fail system monitor has a built in 15 second fault delay that minimizes nuisance alarms caused by momentary power outages.

NOTE: Do not connect AC power and back up battery until ALL system wiring is completed. Also do not bundle the AC wires with zone input or keypad wires.

2.1.2 SECONDARY POWER SUPPLY (BACK UP BATTERY)

To maintain proper operation, the SC system must have a 12 volt rechargeable gel type battery installed. The system was designed to support a 4 to 18 amp hour (AH) battery. The system provides a float charge of 13.75VDC and provides continuous charging current when operating at the suggested rated power output.

Once AC power is lost to the system, the battery automatically takes over. The SC system continuously monitors the battery condition with or without the AC power removed. If the battery voltage falls to an 11.0VDC level, the low battery detector will activate and a low battery trouble condition will be annunciated at the keypad. The trouble condition will exist until the battery voltage reaches an acceptable level.

To silence the trouble enter the fault mode key sequence at the keypad. [PPPP]+

The low battery system monitor also has a built in 15 second fault delay that minimizes nuisance alarms.

For UL Installations, refer to sections X and XI, UL Compliance Verification.

2.1.3 12 VOLT POWER OUTPUTS AUXILIARY POWER TERMINALS (+12.5VDC 3, 4, COMMON 5,6)

Unswitched DC power is available for powering auxiliary devices such as motion detectors. This output is protected by a 2 amp auxiliary power fuse F2. Negative termination for auxiliary devices are wired to terminals 5 or 6.

Current requirement for an SK1L, LCD keypad is 100mA.

See Section 9, UL Compliance.

2.1.4 SMOKE POWER (TERMINALS 10 & 11)

Switched power is available for devices that require an interruptable power source such as smoke detectors. Negative (switched) termination for smoke detectors are wired to terminal 11. To enable this feature a "7" must be programmed in item 30 - Second Miscellaneous Function select. Once programmed, pressing the [1] and [3] keys simultaneously will reset the smoke output for approximately 5 seconds.

See Section 9, UL Compliance Verification.

2.1.5 ASSIGNABLE OUTPUT (TERMINAL 7 & 8)

Normally this terminal provides a **burglary bell** function. If desired, this terminal can be programmed to follow any one of the items in table 1, (refer to programming description, item 33). If the assignable output has been selected for any function other than burglar operation, **single bell** operation must be selected.

NOTE: The total amount of available current from the Auxiliary, Keypad, Smoke, and status outputs (Arm, ready, Audible warning, and Courtesy) is 600mA.

For UL installations, refer to sections X and XI for power loading considerations.

+12VDC OUTPUT OPTIONS FOR TERMINAL 8

Burg Bell (Default)	Audible warning
Arm/Disarm	Courtesy
Strobe light	Timer control switch
Fail to communicate	Keypad control switch
Arm/Disarm/Alarm	P.C. control switch
Ready trouble	

2.1.6 BELL OUTPUT (TERMINALS 7 & 9)

If **dual bell operation** is selected, this terminal is activated whenever a fire loop is shorted. A 12-14Vdc bell or siren may be connected to this terminal, providing the current draw of the device does not exceed 2 amps.

When **single bell operation** is selected, this terminal will have a steady output for burglary activation and pulsed output for fire activation. Fire activation has priority over burglary operation.

NOTE: Single bell operation must be used for UL installations and current must not exceed 300mA.

NOTE: Single bell operation is indicated by Programming item 33 equalling anything except zero.

2.1.7 REMOTE ARMED OUTPUT (TERMINAL 12)

Output is available for connecting a remote armed indicator. Connect the cathode (-) wire to terminal 12 and return the anode (+) wire to terminal 3 or 4. Output will follow panel armed/alarm status.

2.1.8 REMOTE READY OUTPUT (TERMINAL 13)

Output is available for connecting a remote ready indicator. Connect the cathode (-) wire to terminal 13 and return the anode wire (+) to terminals 3 or 4. Output will follow panel ready/trouble status.

NOTE: Devices connected to terminals 12 and 13 are not to exceed 10mA current draw.

2.1.9 REMOTE AUDIBLE WARNING OUTPUT (TERMINAL 14)

Output is available for connecting a remote prealarm device (piezo or equivalent). The device must operate at 12.5VDC and requires no more than 50mA of current. Connect the positive (+) wire of the device to terminal 3 or 4, return the negative (-) wire to terminal 14. The device will produce a steady tone when in entrance delay and a pulsating tone when in exit delay, test or trouble modes. When the Chime feature is enabled this output will operate along with the keypad sounder for chime, creating a short tone any time a chime zone is violated or restored.

Use UL listed pre-alarm device for UL installations.

For proper installation and to meet FCC requirements, it is recommended that a USOC RJ31X jack and connecting cable be installed.

2.1.10 REMOTE COURTESY OUTPUT (TERMINAL 15)

Output available for connecting a burglar alarm interface to be used for turning on lights during entry and exit delay times. Connect the positive (+) terminal of the interface unit to terminal 15, return the negative terminal to terminal 5 or 6.

Use an X10 BA-284 burglary alarm interface module for UL installations.

2.1.11 REMOTE KEYPAD OUTPUTS (TERMINALS 16, 17, 18)

All keypads wired to the SC system should be connected using three (3) conductor 22 gauge stranded wire. All keypads connected to the control panel must be "Home Run". The total combined length of wire for all keypads is not to exceed 1000 feet.

ALL KEYPAD WIRES MUST BE KEPT AWAY FROM AC AND TELCO WIRING.

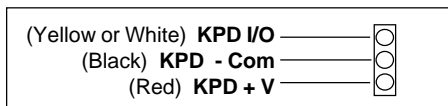

FIGURE 3 - SK1L KEYPAD WIRING

2.1.12 KEYSWITCH INPUT (TERMINAL 19)

The system may be armed/disarmed using a keyswitch. If keyswitch operation is desired, the system must be programmed for all selected burglary zones assigned to user 16. User 16 must not have an access code programmed. Connect the momentary (normally open) keyswitch from terminal 19 to terminals 3 or 4.

2.1.13 TELEPHONE LINE (TERMINALS 20, 22, 23, 24)

The incoming telephone is connected to terminals 20 and 22. Connections to the house phones are wired to terminals 23 and 24. Normally, the control panel connects the incoming line to the house phones using an on board "line seizure" relay. This relay when properly connected prevents anyone from disabling the communicator by picking up one of the house phones. Connection to a phone line with a Fax machine is not recommended.

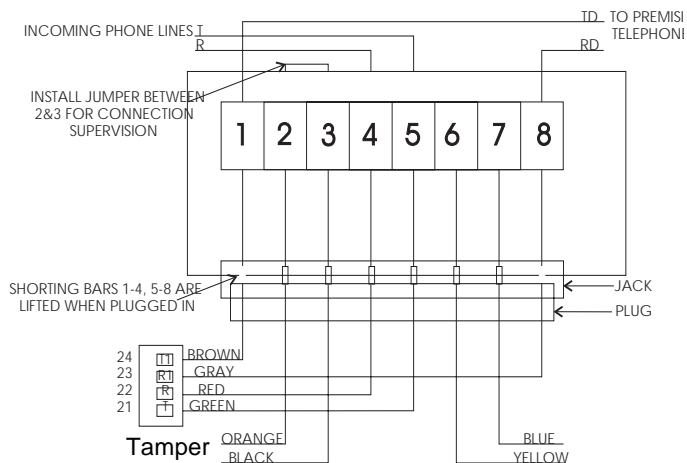

FIGURE 4 - TYPICAL TELEPHONE SYSTEM CONNECTION

THE CONNECTING CABLE MUST BE PHYSICALLY SEPARATED FROM ALL POWER AND SIGNAL LEADS. BE SURE TO INSULATE ALL UNUSED LEADS.

2.1.14 ZONE INPUTS (TERMINALS 25 - 36)

The SC800 system comes from the factory with eight (8) fully supervised zones. The SC1600 is factory configured for sixteen (16) fully supervised zones. These zones can be individually programmed to meet a variety of applications depending on system needs. The (8) zone system may be expanded to (16) zones by adding a Eight Zone Expansion Module (P/N EEM-8) which includes the U11 EEPROM.

The system may be programmed for non-supervised zone operation. Refer to item 30 - Miscellaneous Selections. In this mode, all burglary zones are restricted to Closed Circuit operation. Fire Zones must still use the 2.2K EOL resistor.

For supervised operation, closed circuit loops are wired in series with the resistor. Open circuit loops are wired across the resistor, (refer to Figure 5). Remember that the resistor should be connected in series at the farthest point of the loop. This will allow the use of both open circuit and closed circuit contacts. When connecting a fire loop, the resistor should be placed after the last fire detection device. This will allow correct operation of the trouble signal when the loop is opened.

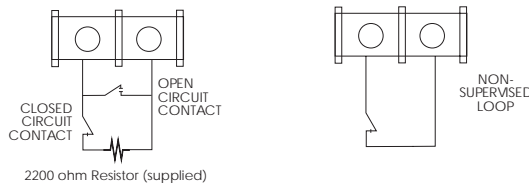

FIGURE 5 - ZONE CONTACT WIRING

2.1.15 EARTH GROUND (TERMINAL 21)

In order for the SC system's surge and transient protection to operate correctly, terminal 21 must be connected to an Earth ground.

The preferred method of protection is to install a separate metal grounding rod. An alternative method of protection, but not as effective, is to connect the earth ground to a metal cold water pipe. In either case keep the wire run as short and straight as possible. When connecting the earth ground, use at least 16 gauge wire between terminal 21 and earth ground.

2.1.16 CONMOD

6 pin connector used to connect DOB modules to panel for bell module, status module, and/or printer interface. See DOB instructions for further details.

2.1.17 INSTALLERS ACCESS CODE JUMPER

Jumper used for resetting the Installers Code. See section 5.4 on page 11 for instructions on use.

SECTION 3: SETUP AND TESTING SYSTEM

3.1 POWERING UP THE CONTROL

Before applying power to the system, recheck all wiring connections, verifying polarity.

Plug the AC transformer into an unswitched 120vac receptacle. Connect the battery leads to the battery. Red lead to the positive (+) terminal, black lead to the negative (-) terminal of the battery. If the battery is not fully charged, allow 36 hours for the battery to fully charge. The keypad will now display system status.

NOTE: Reversing battery wires will cause the factory replaceable fuse FL1 to blow.

Program the EEPROM for the desired system configuration and features. Refer to the SC programming instructions, Section 8 of this manual. After programming is complete, restore the system back to the normal mode.

3.2 TESTING THE LOCAL SYSTEM

The system can be armed and disarmed from the keypad using the factory default code [1111] or any user code previously assigned. The system may also be armed and disarmed using a keyswitch, if so programmed. Leave the system disarmed.

NOTE: Before testing communication to the central reporting station, connect the telephone connection cable into the RJ31-X jack.

Testing the system using the keypad:

Arm the system in the test mode.

Press **[PPPP] + *  + 4  + # **

The audible warning device will pulsate continuously during TEST, except when testing an Entrance Delay zone. During Entrance Delay time, the audible warning device will change to a steady sound (for 4 seconds in the TEST MODE), and then return to a pulsating sound. All loops may now be tested independently. Violate each loop separately. The Arm led will flash and the zone in alarm will be indicated. No need to reset panel after each zone test. Bell or Siren will shut off in 4 seconds and another zone can be tested.

NOTE: Zones violated while in the TEST MODE will not report to the Central Reporting Station. After all zones are tested, Disarm the panel. All audible warning devices will shut off and the Arm LED will turn off.

THE TEST MODE IS NOT AVAILABLE IN THE MULTI-PREMISE PARTITION MODE BUT THE COMMAND CAN BE USED TO CLEAR A "FAIL TO COMMUNICATE" INDICATION.

3.3 TESTING COMMUNICATION TO THE CENTRAL REPORTING STATION

Arm the panel. Violate a zone. The Siren/Bell should turn on, the arm led will flash and the zone in alarm will be indicated, the premise telephone should be inoperative (DEAD). After the Central Reporting Station receives a good transmission of this violation, it will send a "Kiss-off" signal back to the panel and disconnect from the telephone line, returning premise phone back to normal.

SECTION 4: SYSTEM KEYPADS OVERVIEW

There are two different model keypads available for the SC800/1600 of control panels. Model EKP1 LED display (for eight or sixteen zone control panels) and model SK1L LCD English language display. Both keypads are capable of operating the system. The SK1L keypad comes with a snapfit surface mount back box and the EKP1 keypad may be flush mounted. For flush mounting the EKP1 keypad, discard the supplied back box.

The EKP1 cannot be used for system programming. The system can be programmed using the SK1L keypad or ScanPro Downloader uploading/downloading software.

The next few sections of the manual deal with operating and programming the SC800/1600 panels using the SK1L keypad.

NOTE: For panel operation and keypad address programming of the EKP1, please refer to the installation and user manuals supplied with the keypad.

MODEL SK1L - LCD KEYPAD INSTALLATION & OPERATION INSTRUCTIONS

4.1 GENERAL DESCRIPTION

The SK1L alpha numeric keypad features a thirty two (32) character liquid crystal display. Using the soft touch keys and item driven menu, the user can easily understand system operation.

The keypad can be custom tailored for each installation by programming the individual zone descriptions which will be displayed for the system.

The keypad displays system status from one or more locations. Additionally, built into each keypad is a miniature sounding device which when active, indicates various system conditions such as fault, test and pre-alarm warning.

Its attractive design and neutral color can blend easily in a variety of commercial and residential installations.

4.2 SPECIFICATIONS

- Liquid crystal display (LCD) two line 32 character display with backlighting
- Operating voltage 12-16VDC
- Current consumption: 80mA typically 100mA maximum
- Temperature operating range 32° F - 120° F
- For indoor use only
- Dimensions: 4.68• H x 6.58• W x 1.2• D
- Shipping weight: 11 ounces
- Color - Beige
- Backlit, Rubberized keys

4.3 FEATURES

- 3 wire installation
- "Super twist" LCD display that provides wide viewing angle with high contrast
- Time and date or download message displayed during standby condition
- Programmable zone descriptions
- Surface mountable to any flat surface
- Multi Function Piezo
- Separate user and installer programming options
- LCD backlight activated when any key is pressed,
- EEPROM memory retains information during power loss

4.4 KEYPAD CONNECTIONS MOUNTING AND WIRING

1. Remove the keypad from the packing box. Verify that the user manual is included.
2. Unsnap the keypad from the rear mounting plate.
3. Mount the keypad in a dry area that maintains a temperature between 32° - 120°F. The keypad can be mounted to any flat indoor surface.
4. Each keypad requires three (3) wires from the control panel. It is recommended that the wire be a minimum 22 gauge. Standard four (4) conductor cable can be used leaving one (1) conductor as a spare.
5. A total of four (4) keypads can be connected to the system with the maximum wire length, not to exceed 1000 ft. All keypad connections must be "Home Run" back to the panel, meaning all wires must directly return back to the control panel.

NOTE: KEEP KEYPAD WIRING AWAY FROM AC AND TELCO LINES.

6. Using the rear mounting plate as a template, mark the mounting holes. The suggested mounting height is between 48 and 54 inches from the floor to the top of the keypad. This will provide the best viewing angle for most users.
7. Fasten the mounting plate using appropriate hardware (not supplied), making sure the wire is pulled through the opening provided.
8. Refer to Figure 3, Connect the control panel wires to the keypad.
9. "Snap" keypad onto mounting plate.

4.4 KEYPAD POWER UP CONDITION

When power is applied to the keypad, the LCD display will show system status. Normally on the initial power up, if all detection zones are secure, the keypad will display the “ready” condition along with the time and date. A downloaded message can be programmed to display from a remote PC instead of the time.

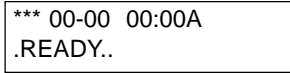

4.5 KEYPAD DESCRIPTION

1. READY (GREEN) LED - When on indicates that all protected areas are secure and the system is ready to be armed. A blinking ready led indicates a fault condition.
2. ARM (RED) LED - When on indicates the system is armed or on. A blinking armed led indicates that an alarm has occurred.
3. MULTI FUNCTION PIEZO - Provides steady and pulsed tones to indicate various system conditions. The piezo will emit a steady tone for entrance delay warning and ring back to acknowledge C/S kiss off. The piezo will emit a pulsed tone for exit delay, test, and fault functions.
4. EMERGENCY KEY PAIRS - Any one or all of the key pairs may be enabled to locally annunciate and or remotely report emergency conditions or both. Note that the key pairs are displayed by the use of symbols. A label has been provided to identify to the user the programmed use for each key pair.
5. SOFT TOUCH KEY PAD - Used to enter all operational and programming commands.

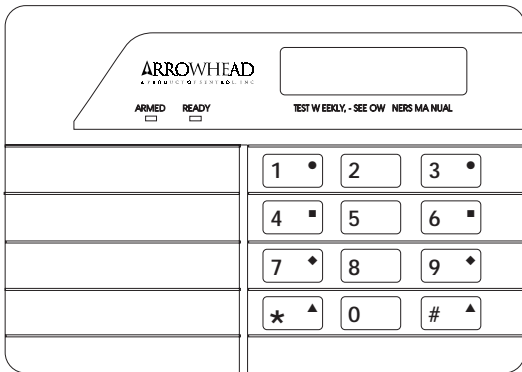

FIGURE 6 - SK1L LCD KEYPAD DESCRIPTION

4.6 KEYPAD KEY SEQUENCE DESCRIPTIONS

FUNCTION KEY

The "Function" key is used in combination with other keys following your passcode to enter various system operation modes. (Note that when in any programming menu that this key becomes the "Escape" key.)





GROUP 1 KEYS

[PPPP] +  **1** The "Group 1" key sequence is used to bypass all burglary zones assigned to Interior Group 1.

GROUP 2 KEYS

[PPPP] +  **2** The "Group 2" key sequence is used to bypass all burglary zones assigned to Interior Group 2.

2 DIGIT KEYS





  The "2 Digit" keys are used to enter hexadecimal numbers A-F.

EXAMPLE: An "F" entry is required

Press:   +  + 



The "2 Digit" keys are also used whenever user needs to enter a zone value greater than 9.

EXAMPLE: To bypass zone 13, Press:



[PASSCODE] +   +  +  + 

In the program mode, the [1&2] key pair is used to indicate the additional zones that are hidden by screen limits.



TEST KEYS

 +  The "Test" key sequence is used whenever a system self test is required.

FAULT KEYS

 +  In the non auto scroll mode, the "Fault" key sequence is used to access the fault analysis mode to analyze a general system failure. It is also used to display the status of a violated zone.

SYSTEM DIRECTORY KEYS

 +  The "System Directory" key sequence is used to view all the zone descriptions. This is very useful in the non auto scroll mode where the zone descriptions are not displayed and the zone description is needed with the zone number.

MENU/UP CURSOR KEY

 The "Menu/Up cursor" key has two functions. The menu key is initially used to access both installer and user menus. While in Programming, the "Up cursor" is used to view and "scroll up" through each description.

DOWN CURSOR

 The "Down cursor" key is used in the installer and user menus to view and "scroll down" through each description.

ESCAPE KEY

 The "Escape" key is used to exit any installer or user programming sequence. The Escape key is also used to cancel any incomplete key sequence before the "Enter" key is pressed. (Note that when not in programming menus this key is the "Function" key.)

ENTER KEY

 The "Enter" key must be pressed following every command sequence so that the system will recognize the command.

LEFTCURSOR KEY

 In the program mode, the "left cursor" key is used to move the cursor in the menu to the left.

RIGHT CURSOR KEY

 In the program mode, the "right cursor" key is used to move the cursor in the menu to the right.

SECTION 5: USER/INSTALLER MENUS

There are two menus available for the SC system, one for the User and one for the Installer. Each menu has specific options that are designed to aid in system operation and provide a convenient method for changing system features.



5.1 USER MENU OPTIONS

The list of User selectable functions can be initiated by accessing the User menu. To access the menu, enter the following key sequence:

[PASSCODE] + 

The first item of the menu will be displayed. The following is a list of all User selectable menu items as they would appear in sequential order on the keypad display. You can restrict the user from accessing any or all of these programming functions, refer to programming item 67, User Attributes.

SET TIME/DATE	ANSWER CALL
SET ENTRANCE DELAY	CALL STATION
SET EXIT DELAY	EDIT ZONE NAME
EDIT USER CODE	

To select a menu item, press the   key.

To advance to the next item, press the  key.

To exit the menu, press the   key three to four times.

5.2 INSTALLER MENU OPTIONS

The list of Installer selectable functions can be initiated by accessing the Installer menu. To access the menu, enter the following key sequence.



   + [INSTALLERS CODE] + 

The first item of the menu will be displayed. The following is the list of Installer menu options in sequential order as they would appear at the keypad.

SET TIME/DATE	EDIT ZONE NAME
SET ENTRANCE DELAY	EDIT USER CODE
SET EXIT DELAY	



(These items are described in the users manual.)

CALL STATION	COPY PROM
ANSWER CALL	SEND
PROGRAMMING	RETRIEVE
VIEW HISTORY	

To select a menu item, press the   key.



To advance to the next item, press the  key.

To back up to a previous item, press the  key.

To exit the Installer menu, press the   key three to four times.

5.2.1 CALLING A PC STATION

To enable the CALL STATION feature, the third phone number must be programmed with the telephone number of the PC station. The reporting format for the third telephone must be selected for ScanPro.

Enter the installer, or user menu, select CALL STATION and press  . The system will set up using the previously programmed information and call the PC station.

An example for the Call Station feature would be: If the PC was set up with new system programming and is currently in the unattended mode, the Call Station option could be used to “download” the new program information.

5.2.2 ANSWER CALL

See page 17, Section 7.4, ANSWERING A CALL FROM THE KEYPAD.

5.2.3 PROGRAMMING MODE

See page 15, Section 6.0, PROGRAMMING INSTRUCTIONS.













5.2.4 VIEW HISTORY

The View History option allows reviewing of the last sixty (60) events that occurred to the system if both EEPROMs are installed. This option is very useful in tracking system problems, since all events are saved in a chronological order with time and date for each event. Event number sixty (60) was the last event to occur. If a single EEPROM is used, the total amount of events available is twenty one (21).

To View History, select the command from the installer's programming menu or select as follows using a user's passcode:

[PPPP] +   +    +  +  +  

To clear panel History, use Installer's code in the following sequence:

   + [||||] +   +    +  +  +  

To print panel History to a local printer, (using a DOB and Printer must be enabled in location 30 of programming) use a user's passcode in the following sequence:

[PPPP] +   +    +   +  +  

Enter the Installer menu and select “View History”. The most recent history event will be displayed immediately. Each history event will be displayed in the following format.

Zone or Auxiliary type report:
 NN TY MO-DD HR:MM ----line 1
 (zone/aux. numbers) ----line 2

Emergency or Station report:
 NN TY MO-DD HR:MM ----line 1
 STATION ## ----line 2

Opening or Closing report:
 NN TY MO-DD HR:MM ----line 1
 USER ## ----line 2

Where,
 NN --Event number
 DD --Day of occurrence
 TY --2 character event type (listed below)
 HR --Hour of occurrence (24 hour based)
 MO --Month of occurrence
 MM --Minute of occurrence

The 2 character event type (TY) are listed as follows:

AL --Zone(s) in alarm
 AR --Alarm memory reset by user
 TB --Zone trouble report
 RT --Zone restore report
 BP --Zone bypass report
 AX --Auxiliary report(s)

E1 --Keypad emergency #1 report
 E2 --Keypad emergency #2 report
 E3 --Keypad emergency #3 report
 E4 --Keypad emergency #4 report
 DA --Door Access ie. "Door Strike"

DU --Duress report
 OP --Opening report
 ST --Station report
 ET --System Test Mode
 CL --Closing report

#1 - Low battery #4 - AC restore
 #2 - AC fail #5 - 24 hour test
 #3 - Low battery restore #6 - Up/Down load
 #7 - Fail to communicate

TO STEP BACKWARD ONE EVENT:

To view the previous event, simple press the  arrow key.

TO STEP FORWARD ONE EVENT:

To view the next available event, simply press the  arrow key.

TO EXIT THE VIEW HISTORY MODE:

To exit the view history mode, press the  key twice. This step must be done if history viewing is no longer desired since the system will not automatically exit this mode.

5.2.5 COPY PROM

The Copy Prom feature is used to duplicate a previously programmed EEPROM, the following procedure must be followed:

1. Power down the panel.
2. Install the pre-programmed EEPROM into the first EEPROM slot marked U10, the new EEPROM to be programmed should be inserted into the second slot marked U11.
3. Place the installer "Pass Code Programming" link P1, on the panel to the upper "Programming" position.
4. Power up the panel again.
5. Enter the installer menu. **NOTE: If the installer code is unknown, follow the procedures described for initializing a new installer code (SECTION 5.4).**
6. Select the "Copy Prom" option from the menu. The system will start the copying process as soon as the  key is pressed. The process will take approximately 3.5 seconds. The display will show the message "Process Passed" if the EEPROM is copied and verified, otherwise the message "Process Failed", will be displayed. Enter the installer code again to clear the message.
7. Return the P1 link to the "Normal" position.

5.2.6 PROGRAMMING THE KEYPAD ADDRESS

1. Enter the following sequence at the keypad to activate keypad programming mode:



2. When you enter programming mode you will be at location 0. This is indicated by the top line in the display saying ADDRESS and there will be a colon, at the left, on the second line of the display. The cursor will be to the right of the colon.
3. Using the number keys you can put in the keypad address value. The keypad address can range from 0 to 3. This is the only location in the SK1L keypad that needs to be programmed. To change the keypad address put the cursor on the position next to the colon and enter a new value. After entering the value you want press the  to save the new value.
4. To exit keypad programming enter the following sequence:



5. The panel is now in normal mode and will operate as a control panel. You must use the correct keypad number when in partitioned mode to assign the keypad to the partition you intend.

5.3 PROGRAMMING KEY FUNCTIONS

Some keys have a different meaning in the programming mode depending upon the individual data type.

5.3.1 NUMBER KEYS

Number keys (1 through 9, and 0) are generally used as number entry for all different data types. However, with zone description entry, each number key represents a list of four different characters; the number itself and three other English alphabet letters as shown in the following chart. Pressing down the same key several times will show the desired character on the display.

Table 2 identifies the characters available from the Number Keys.

1 A B C	2 D E F	3 G H I
4 J K L	5 M N O	6 P Q R
7 S T U	8 V W X	9 Y Z ' ,
0 / .		

TABLE 2 - KEYPAD PROGRAMMING CHARACTERS

5.3.2 ENTER KEY



The [#] key has a dual function. First, it can be used when you want to select a program item for programming as in selecting a phone number. Once programming of an item has been completed, the enter key is used to “store” the entry into the system memory.

5.3.3 LEFT AND RIGHT ARROW KEYS



The [left] and [right] arrow keys are used for cursor movement once a program selection has been made.

5.3.4 ESCAPE KEY



The [*] key is used to exit through the various programming levels. For example, once a user code has been entered at the data level for item 66, pressing the escape key will exit the data level and the prompt will move to the sub group item level indicating user number.

Once all programming is complete, the [*] key is used to exit the programming mode and return the system to the normal mode of operation.

5.3.5 NEXT/PREVIOUS KEYS



The [Next] and [Previous] keys are used to sequentially move through the program menu regardless of which programming level is selected. When the [Down arrow] key is pressed, the menu is advanced to the next programming item. When the [Up arrow] key is pressed, the menu is returned to the previous item selected.

5.3.6 CLEAR LINE



Pressing the [1] and [3] keys simultaneously will clear the entire line on the editing window for any data type. If the data value is to be deleted from the permanent EEPROM memory, the [#] key must be pressed following this function.

5.3.7 DELETE CHARACTER



Move the cursor under the desired character to be deleted, then press the [4] key and [6] key simultaneously to delete that character. Any character or number being deleted from the display will be removed permanently from the system after the [#] is pressed.

5.3.8 LINK KEYS



The [7] and [9] keys, pressed simultaneously, between two numeric entries, will select all digits (inclusive of the selected digits) between the selected numeric keys.

EXAMPLE:

Press the [1] key followed by the [7&9] and then the [6] key. The display will show that all digits 1 through 6 were selected.

NOTE: If you are selecting a 2 digit number you must still use the [1&2] keys prior to the 2 digit zone number.

5.4 REPROGRAMMING A NEW INSTALLER CODE WHEN THE OLD CODE IS UNKNOWN

If for any reason the installer code is lost, follow the procedures below to re-initialize a new installer code.

1. Move the installer “Pass Code Programming” jumper P1 on the panel to the programming position for one (1) second, then move back. The display on the keypad will read the following:

```
Installer Code
XXXX
```

2. Enter the new four digit installer code followed by the [#] key.
3. Press the [*] key after the installer code is entered.

NOTE: If User #1 Pass Code appears after the Installer program jumper is moved, the system has the Installer Privacy feature set. If this feature has been set, and the Panel Password is known, the panel can be reprogrammed using the ScanPro software on a remote PC. If the Panel Password for downloading is unknown and the Installer Code is unknown, the EEPROM will need to be replaced in order to access programming.

SECTION 6.0: PROGRAMMING INSTRUCTIONS

IT IS STRONGLY RECOMMENDED THAT THE DEFINITION SECTION OF THE PROGRAMMING INSTRUCTIONS BE READ BEFORE ATTEMPTING TO PROGRAM THE SYSTEM.

6.1 PROGRAMMING MODE

The SC system must be placed into the programming mode before any programming can begin. See "Keypad Programming" for instructions on entering the Installer Keypad Programming mode. Upon successful entry into the Programming mode the display should read the following:

```
Enter Prog #1
Phone
```

When programming the SC800/1600 system, there are three (3) programming levels available.

6.2 LEVEL 1 - MAIN ITEM GROUP PROGRAMMING

This level identifies which programming item has been selected with its associated item number.

EXAMPLE:

```
Enter Prog #1
Phone
```

The example shows that programming item 1 phone number has been selected.

In this programming level, the cursor or prompt appears for the programming item number entry. The **[up arrow]** and **[down arrow]** keys are used to scroll back and forth through the menu displaying the item numbers and their associated item descriptions.

A program item may be directly accessed by entering its programming number, then pressing the **[#]** key.

6.3 LEVEL 2 SUB GROUP ITEM PROGRAMMING

This level allows movement within the selected sub group item. Sub group item contents reflect options of the main group programming items.

EXAMPLE:

Main program item 66 - user codes has been selected.

The display will show the following:

```
Enter Prog #66
User Code
```

Press the **[#]** key, the display will then show the sub group item for item 66 - the user codes available, in this case user number 1.

```
User Code #1
: _
```

The system will display the third programming level, as indicated by the cursor located in the data field. To access level 2 programming, press the **[*]** key. The cursor will move to the sub group item number field.

```
User Code #1
:
```

You may now move within the sub group item field. Example: Using item 66 - Pass Codes above, the sub group items displayed are the individual user codes. Currently user #1 is being displayed. To view user 12 pass code, press: **[1] [2] [#]**.

The display will then read the following:

```
User #12
: _
```

The display will show the contents of the selected sub group item in this case user #12's pass code.

6.4 LEVEL 3 DATA PROGRAMMING

This level identifies the actual data of the selected program item or sub group item.

EXAMPLE:

Item 1 phone number has been selected. The display will read the following:

```
Enter Prog #1
Phone
```

Pressing the **[#]** key, the display will show the number programmed for telephone number 1. Since no telephone number was previously entered, the data field will appear blank.

```
Phone #1: _
```

The cursor will appear in the data field.

The **[LEFT]** and **[RIGHT]** arrow keys are used for cursor movement on the data display line. If data is currently displayed, the new data can be re-written right on top of the old data. However, if clearing the line is necessary, do so using the clear line key combination.

EXAMPLE 1: PROGRAMMING NUMERIC DATA

The new phone number is to be 1 800 777 1313. If data is currently displayed, press the clear line key combination. The display should read the following:

Phone #1: _

Enter the new phone number, Press [1],[8],[0],[0],[7],[7],[7],[1],[3],[1],[3].

Phone #1: 1 8 0 0 7
7 7 1 3 1 3 _

After the new data is entered, press the [#] key so the new data is updated to the permanent EEPROM memory. The new phone number is 1 800 777 1313.

Pressing the [down arrow] or [up arrow] keys while in the data level of programming will allow scrolling through the individual data items.

6.4 PROGRAMMING ZONE DATA

Programming zone data is the same as programming numeric data. If you make a mistake and insert a zone number which is not wanted, simply press that number a second time and it will be removed.

SECTION 7.0: SPECIAL PANEL FEATURES

7.1 REMOTE PROGRAMMING (Up/Downloading)

The SC800/1600 system has the ability to be reprogrammed and controlled from a remote location over the standard telephone network, using an IBM PC or compatible computer equipped with a modem and ScanPro Downloader Software. The system may have individual memory locations programmed or the contents of the entire memory may be uploaded/downloaded in less than two (2) minutes. For more information on the ScanPro Downloader Software, contact Sentrol, Inc.

7.2 AUTO CALL ANSWER METHOD

This method requires a set number of rings to be programmed along with the correct panel password. The remote PC will call the premises. After the control panel has sensed the set number of rings, it will seize the phone line and begin communication with the remote PC.

If the phone line is answered by any other device than the panel (I.E.. Answering machine, person, etc.), the panel will sense the tones from the computer and seize the phone line from the device. This procedure will operate properly only if the telephone devices are installed on the "house phones" side of the Line Seizure circuitry as shown in FIGURE 4, page 5.

7.3 PANEL CALL BACK SECURITY (for secure Up/Downloading)

This method requires the following items to be programmed, a set number of rings, the correct panel password, and the secure upload/download feature selected. The remote PC dials the premises. The control panel at the premises will pick up the phone line and if the computer responds correctly, the control panel will hang up and dial the call back telephone number. If the control panel does not receive the proper response or if the call back number is not answered within a preset time, the control will hang up and try to initiate another call. The control panel will continue to dial to the preset number of dialing attempts. Using this method provides a higher level of security because the PC that is calling the premises must be the one selected with the call back number. This will almost eliminate all "Unwanted Parties" from gaining access to the system.

7.4 ANSWERING A CALL FROM THE KEYPAD

This is the only way the panel can answer the call if zero rings are programmed. The Answer Call option can be used at any time to pick up an incoming call, from a PC or another panel. The user or alarm technician must be instructed to enter the user menu and select the **Answer Call** option once the telephone begins ringing at the premises. After the [#] key is pressed, the control panel will seize the phone line and begin communication.

This option is also required in situations where a direct connection is used to program the panel. Attach the modem to the panels Ring and Tip. Activate the "Answer Call" after ScanPro begins emitting the modem tone.

7.5 "LIMITED ACCESS" PROGRAMMING

This feature allows the system to be tailored for the end user. The system can be programmed to allow a particular access code access to a limited number of zones.

An example of "Limited Access" in a residential system might be: With an eight (8) zone system and a single keypad. The user is assigned all eight (8) zones while the maid is assigned all zones except zone eight (8) protecting a wall safe. Only the user is allowed access to the safe without setting off the alarm system. The programming required for this "Limited Access" example would be as follows:

Item 52 - Zones assigned to keypad.

Program zones one (1) through eight (8) for keypad 1, keypad address of "0".

Item 66 - User pass codes

Program two (2) pass codes one (1) for the user and one (1) for the maid.

Item 68 - Zones assigned to user

Program user #1 for zones 1-8 and user #2 (the maid's code) for zones 1-7.

To arm the entire system, all partitioned areas must be armed. In this example, user 1 the user, was assigned all zones one (1) through eight (8). When he arms, the Armed led will be on and the display will show the armed condition. If the maid armed the system, she would only have armed her partitioned area zones one (1) through seven (7). The display would show the armed and bypassed condition.

Using the above example, when the user code is used that is assigned less zones than the amount of zones assigned to the keypad, the unassigned zones would appear as BYPASSED and the assigned zones would be ARMED.

7.6 PARTITIONING

A partition is a restricted area consisting of one or more zones. You may restrict a user, a keypad or both from arming/disarming a zone or group of zones.

An example of "Partitioning" in a Commercial Installation might be: A sixteen (16) zone system with two areas to protect such as an office as partition one and a warehouse as partition two. These are two totally separate areas and will be monitored from their own keypads. We will assume that Users 1-12 will control the first partition (zones 1- 10) and that Users 13-21 will control the second partition (zones 11-16). User 1 and 2 will need to have access to both areas.

The programming required for this partitioning example would be as follows:

Item 30 - Miscellaneous system function select

Program in Group 2 a "2" for multi-premise operation. This keeps the areas separate. Without this bit set User codes from one area have control over the other area.

Item 52 - Zones assigned to keypad.
Program zones one (1) through twelve (12) for keypad 1, keypad address of "0". Program zones thirteen (11) through sixteen (16) for keypad 2, keypad address of "1".

Item 66 - User pass codes
Program the first group of users (1-12) that will access the office. Program the second group of users (13-21) that will have access to the warehouse. User codes 1 and 2 would be duplicated as users 13 and 14.

Item 67 - User Attributes
Program user 13 as the User Group Boundary. This user is now identified as the first user of the second partition.

Item 68 - Zones assigned to user
Program users 1-12 with zones 1-10. Program users 13-21 with zones 11-16. This location can also be used to have the "Limited Access" feature by simply omitting the zones a particular user will not have access to.

7.7 DISARMING THE SYSTEM

As in arming the system, the entire system must be disarmed to display the ready status. Referring to our previous example in section 7.5, if the maid disarmed the system, she would have only disarmed her partitioned area zones one (1) through seven (7). Zone eight (8), the safe, would still be armed and zones 1-7 would indicate BYPASSED.

7.8 COMMON ZONING

SC System partitioning is very flexible. Both users and keypads may control common zones (an example would be a hallway common to a set of offices).

EXAMPLE:

An example of Common Zoning would be four doctors offices sharing an SC800/1600 panel. Each office is given a separate keypad with its own unique address. Each office (keypad) can now be assigned a group of different zones (partitions) and finally each office is assigned user codes with the user group assigned to zones of their associated office. The common zone will be zone 1 shared by all users and partitions. For "Common Zoning", each partition must have a separate group delay assigned to it.

The programming required for this partition example would be as follows:

Item 52 - Zones assigned to keypad
Program zones two (2) through four (4) for keypad 1, keypad address = 0.
Program zones five (5) through eight (8) for keypad 2, keypad address = 1.
Program zones nine (9) through twelve (12) for keypad 3, keypad address = 2.
Program zones thirteen (13) through sixteen (16) for keypad 4, keypad address = 3.
Refer to the keypad installation manual for proper keypad programming.

Item 30 - Miscellaneous system function select
Program second miscellaneous system function select with a "2" for multi-premise operation.

Item 66 - User pass codes
Program all thirty two (32) user codes.

The SC800/1600 system has the capability to allow thirty two (32) users to operate the system. In multi-premise partitioning, these users must be assigned to the specific keypad area they will control. This is accomplished by setting up a **user boundary** - programming an eight (8) in item 67 - user attributes for the **first user of the second, third and fourth** partitions.

Any user who is allowed to change codes will have the ability to alter **any and all** of the system user codes regardless of which partition to which he is assigned.

Item 67 - User attributes
In an equally divided 32 user system as in the example the user attribute 8 would be programmed at users 9, 17 and 25.

Item 68 - Zones assigned to user
Program the zones assigned to each individual user of the system. Users 1-8 would be programmed for zones 1-4, users 9-16 programmed for zone 1 and 5-8, users 17-24 programmed for zone 1 and 9-12, and users 25-32 programmed for zone 1 and 13-16 .

One or more of the offices may have a sub-partition (partition within a partition). For example, users 6,7 and 8 of partition one may be denied access to the drug cabinet by not assigning these users the zones associated with the drug cabinet.

PROGRAMMING CONSIDERATIONS

Common zoning is accomplished by assigning Zones per Keypad in Item 52 that are strictly for that partition, except the common zone(s). Assigning all common zones to appropriate users in Item 68 is how the operation is implemented. This will allow the first partition disarmed to disarm the common zone(s) and the last partition armed will arm the common zone(s). While the common zone is disarmed, the zone will indicate as "Bypassed" on any and all keypads that are in the armed state.

These zones must be specified as Entry/Exit Zones only and assigned to an E/E Zone Delay Group. All partitions must have at least one of their zones programmed into their respective Delay Groups. In the above example zone 1 would be in 41 and 42 for Group #1, Z5 would be in 42 for Group #2, Z9 would be in 42 for Group #3 and Z13 would be in 42 for Group #4. Each keypad then would tone during the Entry time as well as the Exit time. It is recommended that the Entrance/Exit times be set the same for all of the partitions to minimize nuisance alarms caused by inadequate disarm time. Any alarm report generated for the common zone will be reported to Partition (1) Account number.

7.9 MULTI-PREMISE SYSTEM OPERATION

System operation in multi-premise partitioning is the same as it would be in the normal mode of operation except that the following two system features are unavailable:

Automatic Bell Test Test Mode

7.9.1 BELL OPERATION

In multi-premise partitioning, each keypad area 1 through 4, can be assigned an individual bell, provided a Data Output Board DOB is installed. If individual bell operation is desired, item thirty (30), third miscellaneous system function select must be set for a 1 -output bell module installed.

Refer to DOB (Data Output Board) instructions for installation and wiring.

In multi-premise partitioning, if a single bell is used and an alarm occurs, it must be silenced from the keypad associated with the zone that initiated the alarm, unless "Silence All Area Bells" in Item 30, First Misc. Select, is set for an eight (8) - Silence All Area Bells.

7.9.2 FIRE ZONES

All fire zones are shared in multi-premise partitioning so that the alarm condition will be displayed at all locations. The alarm can be silenced from any keypad area.

Warning: If this system is used for fire protection, special care must be taken in the installation, the sensor selection and their placement. Follow all NFPA guidelines and make sure that all system components and wiring are protected by approved fire sensors.

7.9.3 SHARED ZONES

Shared zones are defined as any zones that are required to indicate status at each of the shared keypads of a partitioned system. The individual zones to be assigned are placed in Item 52. Activated 24hr. zones may be silenced from any keypad.

To silence an alarm created by a shared burglary zone type, the feature Silence All Area Bells must be elected in item 30 of programming.

7.9.4 INCREMENTING ACCOUNT NUMBERS

This feature is only used in multi-premise/partitioned installations only. This allows the #1 Account number to be incremented by one (1) for each of the partitions. Global research such as AC loss, Low Battery, etc. are reported to the #1 Account number. This is enabled by programming an eight (8) in Item 27, Auxiliary Report Selection for Telephone #2.

Note: Silent Knight receivers using 4 + 2 format are not compatible with incrementing account numbers.

7.9.5 AUTO-ARMING

This is a feature to provide an automatic preselected arming command to be given to the panel. The selected time is placed in item 58. It is enabled by placing an (8) in item 27, Auxiliary Report Selection for Telephone #1. Item #60 must be programmed with each appropriate day that is required for Auto-Arm to occur. If the system is supervised with Open/Close reports, the identifier when this Auto-Arming occurs is user #8.

Remember: If Auto Arming is to be used, select appropriate zones for User #8 in item #68 of the programming.

If the system were to have a zone in violation at the time of arming a Force Arm report would be generated. The fourth digit in the Close code (item #20) is the Force Arm report code and would be transmitted to the central station. This code would precede the zone identifier for each of the zone(s) that had been Force Armed.

IT IS HIGHLY RECOMMENDED TO USE THE FORCE ARM REPORTING FEATURE WITH THE AUTO-ARM FEATURE TO VERIFY SYSTEM SECURITY.

Note: If a Force Arm occurs it MUST be understood that the alarm system IS NOT SECURE and should be investigated to identify why. No signal would be sent if zone contact was made good since the restoral could be a "closed but not locked" door. The site should be inspected any time that a Force Arm signal is sent.

7.9.6 CONDITIONAL OPENING SIGNAL

This is a feature to provide a unique code to the central station when the system has been disarmed after an alarm has occurred. This would signify to the central station that someone was at the site with a viable access code. The code generated will be, the digit 1 or 2 in item #21, followed by the appropriate user code.

Note: This feature WILL NOT work in conjunction with Open/Close.

7.10 PANEL OPERATION USING THE SCANPRO DOWNLOADER SOFTWARE

The panel can be accessed, status viewed and remotely Armed/Disarmed using the ScanPro Downloader software. If the software is used to Arm or Disarm and Open/Closes has been selected the central station will receive the user identifier for user 15.

If Open/Close reporting is selected and ScanPro is used to Arm or Disarm the system the Upload/Download Code should be enabled with a special digit so that it would accompany the User 15 reporting code. This would allow the central station to be able to differentiate the two users.

SC1600 PROGRAMMING WORKSHEET

for programming through ScanPro/Keypad

If you enter: 1 2 3 4 5 6 7 8 9 10 11 12 13 14 15 HEX CONVERSION CHART

Program ITEM #	DESCRIPTION	NEW DATA ENTRIES	FACTORY DEFAULT
1	1ST TELEPHONE NUMBER		
	2ND TELEPHONE NUMBER		
	3RD TELEPHONE NUMBER		
2	ACCOUNT NUMBER 1 ("Auto Increment of Acct #1 by Partition")		
	ACCOUNT NUMBER 2 -enable by putting "8" in Item 27 Phone 2)		
	ACCOUNT NUMBER 3		
3	REPORTING FORMATS: 1=FAST 2=EXT FAST 3=ACRON 4+3+3 4=SK4+2/20PPS 7=SLOW 8=EXT SLOW 9=SK4+2/10PPS 10 = ScanPro FSK 11=40PPS Extended w/ Parity 12=40PPS 4+2 w/ Parity		
	RECEIVER #1 FORMAT SELECT ONE FORMAT		
	RECEIVER #2 FORMAT SELECT ONE FORMAT		
	RECEIVER #3 FORMAT SELECT ONE FORMAT		
4	REPORTING ATTEMPTS (0-15) - 0=16 ATTEMPTS		8
5	ANTIJAM TIME IN SECONDS 0-99 SECONDS		20
		1 2 3 4 5 6 7 8 9 10 11 12 13 14 15 16	
6	RESTORE ZONES SELECT ZONE(S)		
7	ZONE RESTORAL CODE ZONE BLOCK CODE DIGITS		
8	TEST CANCEL ZONES SELECT ZONE(S)		
9	TEST CANCEL CODE ZONE BLOCK CODE DIGITS		
10	LOW BATTERY CODE 2 DIGIT REPORT CODE		<p>ZONE BLOCK CODE DIGITS - 1st Digit used as the Event code for the 1st block of eight zones. It is followed by the Zone ID from Item 25 for zones 1-8.</p> <p>2nd Digit used as the Event code for the 2nd block of eight zones. It is followed by the Zone ID from Item 25 for zones 9-16.</p>
11	A/C LOSS REPORT CODE 2 DIGIT REPORT CODE		
12	LOW BATTERY RESTORAL CODE 2 DIGIT REPORT CODE		
13	A/C RESTORAL CODE 2 DIGIT REPORT CODE		
14	TEST CODE 2 DIGIT REPORT CODE		
15	UPLOAD/DOWNLOAD CODE 2 DIGIT REPORT CODE		
16	BYPASS CODE ZONE BLOCK CODE DIGITS		
17	TROUBLE CODE ZONE BLOCK CODE DIGITS		
	KEY PAIR (1 & 3) 1 DIGIT (1- F)	(7 & 9) 1 DIGIT (1- F)	
18	EMERGENCY CODES (4 & 6) 1 DIGIT (1- F)	(* & #) 1 DIGIT (1- F)	
19	DURESS CODE 1 DIGIT (1- F)		
20	CLOSING CODE Four Digit Code		(Close Code) 1st digit = Users (1-15), 2nd = Users (16-30), 3rd = "Fail-to-Close" code, 4th = "Force Arm" code
21	OPENING CODE Four Digit Code		(Open Code) 1st digit = Users (1-15), 2nd = Users (16-30), 3rd = "Fail-to-Open" code, 4th = "Conditional Open" enable
22	STATION CODE 1 DIGIT (1- F)		
23	STATUS CODE ZONE BLOCK CODE DIGITS	Select 1 for Grp1,2 for Grp2, 3 for Grp3 and 4 for Grp4	
24	**OPEN/CLOSE BY E/E GROUP 1 - 4 DIGITS		
STEP #24 MUST BE PROGRAMMED WITH AT LEAST 1 FOR BASIC OPENING/CLOSING REPORTING			
25	ZONE REPORTING CODES	Event Code Zone ID DEFAULT	Event Code Zone ID DEFAULT
	ZONE 1	1 - 1	ZONE 9 2 - 1
	ZONE 2	1 - 2	ZONE 10 2 - 2
	ZONE 3	1 - 3	ZONE 11 2 - 3
	ZONE 4	1 - 4	ZONE 12 2 - 4
	ZONE 5	1 - 5	ZONE 13 2 - 5
	ZONE 6	1 - 6	ZONE 14 2 - 6
	ZONE 7	1 - 7	ZONE 15 2 - 7
	ZONE 8	1 - 8	ZONE 16 2 - 8
26	REPORTING ZONE SELECTION	1 2 3 4 5 6 7 8 9 10 11 12 13 14 15 16	
	TELEPHONE NUMBER 1 SELECT ZONE(S)		
	TELEPHONE NUMBER 2 SELECT ZONE(S)		
	TELEPHONE NUMBER 3 SELECT ZONE(S)		
27	AUXILIARY REPORT SELECTION: 1 = EMERGENCY CODES OR DURESS		1 2 3 4 5 6 7 8
	2 = OPENING/CLOSING, STATION 3 = A/C LOSS, LOW BATTERY, UPLOAD, TROUBLE		
	*4 = HISTORY 5 = TEST TIMER A	TELEPHONE # 1 (**8 = AUTO-ARMING ENABLE)	
	6 = TEST TIMER B 7 = STATUS, BYPASS	TELEPHONE # 2 (**8 = INCR ACCT# BY AREA)	
	8 = SPECIAL OPTION SELECTION	TELEPHONE # 3 (8 = FAIL TO COMM. DISABLE)	

* Note: History reporting is for reporting to ScanPro software only

28	ANSWER ON RING # (0-15)	0=NO RING DETECT														10			
29	BURGLARY AND FIRE BELL	BURG OUTPUT (1 & 3)	1													FIRE OUTPUT (1 & 3)	5		
	SELECT FOR EMERGENCY	BURG OUTPUT (4 & 6)	2													FIRE OUTPUT (4 & 6)	6		
	KEY PAIRS:	BURG OUTPUT (7 & 9)	3													FIRE OUTPUT (7 & 9)	7		
	FIRE HAS PRIORITY	BURG OUTPUT (* & #)	4													FIRE OUTPUT (* & #)	8		
30	GROUP 1) MISCELLANEOUS SYSTEM FUNCTION SELECT:		SELECT FUNCTION(S)																
	1=NO END-OF-LINE RESISTORS	5=ZONES 9-16 INSTALLED	1	2	3	4	5	6	7	8									
	2=SECURE UPLOAD/DOWNLOAD	6=2ND EEPROM INSTALLED																5, 6	
	3=INSTALLER CODE PRIVACY	7=LATCHED FIRE BELL OP																	
	4=50 HZ A/C CLOCK	8=SILENCE ALL AREA BELLS																	
	GROUP 2) MISCELLANEOUS SYSTEM FUNCTION SELECT:		SELECT FUNCTION(S)																
	1=AUTOMATIC BELL TEST	5=DISABLE AUTO SCROLL	1	2	3	4	5	6	7										
	2=MULTI-PREMISE MODE	6=DISABLE RINGBACK																7	
	3=TONE DIAL	7=(1+3) KEY PAIR SMOKE RESET																	
	4=EUROPEAN ROTARY																		
	GROUP 3) MISCELLANEOUS SYSTEM FUNCTION SELECT:		SELECT FUNCTION(S)																
	1=OUTPUT BELL DOB MODULE	5=TIMER CONTROL SW 2	1	2	3	4	5	6	7	8									
	2=OUTPUT STATUS DOB MODULE	6=KEYPAD CONTROL SW																	
	3=DISABLE EXIT ANNUNCIATION	7=PC CONTROL SW 1 ON																	
	4=PRINTER DOB MODULE INSTALLED	8=PC CONTROL SW 2 ON																	
31	SWITCHED OUTPUT TIMER	HH:MM																	
32	SWITCHED OUTPUT WINDOW (X 15 MIN)	(0-95)																	
33	ASSIGNABLE OUTPUT SELECTIONS: 0=Dual Bell Feature		ENTER SELECTION																
	0=BURGLAR BELL	4=FAIL TO COMMUNICATE	8=COURTESY																
	1=ARM/ DISARM	5=ARM/ DISARM/ ALARM	9=TIMER CONTROL SW																
	2=DOOR STRIKE	6=READY/ TROUBLE	10=KEYPAD CONTROL SW																
	3=STROBE LIGHT	7=AUDIBLE WARNING	11=P.C. CONTROL SW															0	
34	FALSE ALARM	ZONE 1		ZONE 5		ZONE 9		ZONE 13											
	SHUTDOWN COUNT	ZONE 2		ZONE 6		ZONE 10		ZONE 14											
	(1-15)	ZONE 3		ZONE 7		ZONE 11		ZONE 15											
	0 = UNLIMITED = DEFAULT	ZONE 4		ZONE 8		ZONE 12		ZONE 16									0		
			1	2	3	4	5	6	7	8	9	10	11	12	13	14	15	16	
35	PROGRAMMABLE RESPONSE ZONE SELECT	SELECT ZONE(S)																	
36	ZONE RESPONSE TIME (0-99)	(2+value) x 5msec																	
37	SILENT 24 HOUR ZONES	SELECT ZONE(S)																	
38	AUDIBLE 24 HOUR ZONES	SELECT ZONE(S)																	
39	AUDIBLE 24 HOUR FIRE ZONES	SELECT ZONE(S)																	8, 16
40	AUDIBLE BURGLARY ZONES	SELECT ZONE(S)																	1-7, 9-15
41	ENTRANCE/EXIT ZONES	SELECT ZONE(S)																	1
42	DELAY ZONE GROUP SELECTIONS		1	2	3	4	5	6	7	8	9	10	11	12	13	14	15	16	
	GROUP 1	SELECT E/E & FOLLOWER ZONES																	1
	GROUP 2	SELECT E/E & FOLLOWER ZONES																	
	GROUP 3	SELECT E/E & FOLLOWER ZONES																	
	GROUP 4	SELECT E/E & FOLLOWER ZONES																	
43	ENTRANCE DELAYS (x 10 sec)	SELECTION IN 10 SEC INCREMENTS																	
	GROUP 1	(0-15) 0=NO DELAY																	1
	GROUP 2	(0-15) 0=NO DELAY																	
	GROUP 3	(0-15) 0=NO DELAY																	
	GROUP 4	(0-15) 0=NO DELAY																	
44	EXIT DELAYS (x 10 sec)	SELECTION IN 10 SEC INCREMENTS																	
	GROUP 1	(0-15) 0=NO DELAY																	1
	GROUP 2	(0-15) 0=NO DELAY																	
	GROUP 3	(0-15) 0=NO DELAY																	
	GROUP 4	(0-15) 0=NO DELAY																	
45	REPORTING DELAY ZONES	SELECT ZONE(S)																	
46	ZONE REPORTING DELAY (x 10sec)	(1-15)																	
47	TROUBLE REPORTING ZONES	SELECT ZONE(S)																	
48	DAY/NIGHT ZONES	SELECT ZONE(S)																	
49	BYPASSABLE ZONE SELECT	SELECT ZONE(S)																	
50	CHIME ZONE SELECT	SELECT ZONE(S)																	
51	INTERIOR ZONE SELECT	*NOTE... ZONES MUST BE BYPASSABLE																	
	GROUP 1	SELECT ZONE(S)																	
	GROUP 2	SELECT ZONE(S)																	

52	ZONES ASSIGNED TO KEYPADS:					SELECT ZONES													
	KEYPADS 2-4 USED FOR PARTITIONING ONLY	1	2	3	4	5	6	7	8	9	10	11	12	13	14	15	16		
	Keypad # 1 Set Keypad Address = 0 SELECT ZONE(S)																	1 - 16	
	Keypad # 2 Set Keypad Address = 1 SELECT ZONE(S)																		
	Keypad # 3 Set Keypad Address = 2 SELECT ZONE(S)																		
	Keypad # 4 Set Keypad Address = 3 SELECT ZONE(S)																		
53	ZONE DESCRIPTIONS (16 CHARACTERS PER ZONE)																		
	ZONE 1																		
	ZONE 2																		
	ZONE 3																		
	ZONE 4																		
	ZONE 5																		
	ZONE 6																		
	ZONE 7																		
	ZONE 8																		
	ZONE 9																		
	ZONE 10																		
	ZONE 11																		
	ZONE 12																		
	ZONE 13																		
	ZONE 14																		
	ZONE 15																		
	ZONE 16																		
54	BELL SHUT OFF TIME (x 2 min)	(0-15)																8	
55	AC+LOW BATTERY REPORT DELAY (x 1min)	(0-15)																	
56	TEST TIMER REPORTING TIME	*** MM-DD HH:MM AM/PM																	
	SELECT MONTH, DAY, HOUR AND MIN. FOR (YEARLY) REPORTING			WEEK DAY	MO.	DAY	HOUR	MIN.	A	P									
	SELECT DAY, HOUR AND MIN. FOR (MONTHLY) REPORTING																		
	SELECT WEEKDAY, HOUR AND MIN. FOR (WEEKLY) REPORTING			TIMER A															
	SELECT HOUR AND MIN. ONLY FOR (DAILY) REPORTING			TIMER B															
57	START OF OPENING EXCEPTION WINDOW	HH:MM																	
58	START OF CLOSING EXCEPTION WINDOW	HH:MM																	
	Used as the Arm time for the Auto-Arm feature Enable by putting an "8" at Item 27 for Phone #1																		
59	EXCEPTION WINDOW LENGTH IN 15 min INCREMENTS																		
60	OPEN/CLOSE/STATION EXCEPTION SCHEDULE	1=SUNDAY			SELECT DAY(S)														
	2=MONDAY	3=TUESDAY	4=WEDNESDAY	5=THURSDAY	1	2	3	4	5	6	7								
	6=FRIDAY	7=SATURDAY	Select days for Auto-Arm feature																1 - 7
		MONTH	DAY					MONTH	DAY										
61	HOLIDAYS (MM-DD)	HOLIDAY 1						HOLIDAY 6											
		HOLIDAY 2						HOLIDAY 7											
		HOLIDAY 3						HOLIDAY 8											
		HOLIDAY 4						HOLIDAY 9											
		HOLIDAY 5						HOLIDAY 10											
62	PANEL PASSWORD	USE FOR UPLOADING/DOWNLOADING															1234		
63	NO LONGER USED																		
64	INSTALLER CODE	USE FOR KEYPAD PROGRAMMING															7777		
65	ABBREVIATED ARMING DIGIT LENGTH (all users) (1, 2 or 3)																0		
66	USER ACCESS CODES	1	2	3	4	DEFAULTS	1	2	3	4	DEFAULTS								
	USER 1					1 1 1 1	USER 16												
	USER 2						USER 17												
	USER 3						USER 18												
	USER 4						USER 19												
	USER 5						USER 20												
	USER 6						USER 21												
	USER 7						USER 22												
	USER 8						USER 23												
	USER 9						USER 24												
	USER 10						USER 25												
	USER 11						USER 26												
	USER 12						USER 27												
	USER 13						USER 28												
	USER 14						USER 29												
	USER 15						USER 30												

67	USER ATTRIBUTES:		1=INHIBIT VIEW HISTORY	5=NO E/E OR ZONE DESCRIPTION																							
			2=DOOR STRIKE ONLY	6=INHIBIT ALL PROGRAMMING FUNCTIONS																							
			3=ARMING ONLY	7=INHIBIT ABILITY TO CHANGE OTHER ACCESS CODES																							
			4=INHIBIT BYPASS ABILITY	8=USER GROUP BOUNDARY																							
			1	2	3	4	5	6	7	8	DEFAULTS											DEFAULTS					
		USER 1										USER 16															
		USER 2										USER 17															
		USER 3										USER 18															
		USER 4										USER 19															
		USER 5										USER 20															
		USER 6										USER 21															
		USER 7										USER 22															
		USER 8										USER 23															
		USER 9										USER 24															
		USER 10										USER 25															
		USER 11										USER 26															
	USER 12										USER 27																
	USER 13										USER 28																
	USER 14										USER 29																
	USER 15										USER 30																
68	ZONES ASSIGNED TO USER:										SELECT ZONES																
	USER IDENTIFICATION										1	2	3	4	5	6	7	8	9	10	11	12	13	14	15	16	
	USER 1																										1 - 16
	USER 2																										
	USER 3																										
	USER 4																										
	USER 5																										
	USER 6																										
	USER 7																										
	USER 8																										
	USER 9																										
	USER 10																										
	USER 11																										
	USER 12																										
	USER 13																										
	USER 14																										
	USER 15																										
	(OPTIONAL KEYSWITCH CODE)																									1 - 16	
	USER 16																										
	USER 17																										
	USER 18																										
	USER 19																										
	USER 20																										
	USER 21																										
	USER 22																										
	USER 23																										
	USER 24																										
	USER 25																										
	USER 26																										
	USER 27																										
USER 28																											
USER 29																											
USER 30																											

Defaults are shown for the SC1600 Alarm panel.
The defaults for the SC800 are slightly different and correspond to 8 zones.

SECTION 8: PROGRAMMING ITEM DESCRIPTION

The numbers below that follow the 8 correspond to the keypad programming items as well as the ScanPro items.

When HEX is specified it identifies that Hexidecimal characters (0-9 and B-F) are to be programmed

8.1 TELEPHONE NUMBER

The SC is capable of reporting to three different telephone numbers. Each number may be up to 20 digits in length (with a required blank digit at the end of each number). Refer to items 26 and 27 for telephone number reporting assignment.

Also, four special function may be used in conjunction with the telephone numbers:

1) 11 or B - (* KEY USED TO DELETE CALL WAITING)

The "11" is used to delete call waiting in tone dialing only. 11, 7, and 0 is programmed before the dialed phone number. Use first three Memory Locations. Check with your local telephone company to make sure of the exact digit sequence.

2) 12 or C - (#) KEY

Some telephone exchanges require that the (*) key be used to call out. Simply program a "12" where needed.

3) 14 or E - SECOND DIAL TONE

In installations where two dial tones are received (first for internal line and second for outside line). The panel may be programmed to detect a second dial tone by entering a "14" between the internal line number and the outside line number.

4) 15 or F - DIALING PAUSE

In areas where a dialing pause is required a dialing pause may be programmed after any dialing digit by entering a "15". The dialing pause is approximately 5 seconds.

8.1.1 THIRD TELEPHONE NUMBER

The third telephone number can be used as a third receiver number but it's primary purpose is to denote the CallBack security phone number for the ScanPro Downloader software. When this feature is used for communicating to the software the third account number MUST agree with the account number set up in ScanPro as well as the format MUST be set to (10).

8.2 ACCOUNT NUMBERS

The three account numbers are assigned to telephone numbers 1, 2 and 3 respectfully. These account numbers may be three or four digits in length and with a range of 0-9, A-F. Extended Superfast 4+3+3, SK4+2 and ScanPro Downloader reporting formats require a four digit account number.

8.3 REPORTING FORMATS

Enter a value from the list below to select the transmission format for each telephone number.

- 1=Fast, 2300 Hz. handshake, 1800 Hz. data, 20 pps.
- 2=Fast Extended, 2300 Hz. handshake, 1800 Hz. data, 20 pps.
- 3=Extended Superfast 4+3+3 (DTMF touch tone).
- 4=SK 4 + 2 , 2300 Hz. handshake, 1800 Hz. data, 20 pps.
- 7=Slow, 1400 Hz. handshake, 1900 Hz. data, 10 pps.
- 8=Slow Extended 1400 Hz. handshake, 1900 Hz. data, 10 pps.

9=SK 4 + 2, 1400 Hz. handshake, 1900 Hz. data, 10 pps.

10=ScanPro 300 baud.

11=40PPS Extended with Parity

12=40PPS 4+2 with Parity

8.4 REPORTING ATTEMPTS (0-15)

The value is the number of reporting attempts the system will make before going into a "FAIL TO COMMUNICATE" condition. A new report will re-initiate the attempt counter for all previous reporting attempts. A zero in this location will cause the system to report 16 times.

EXAMPLE: Reporting Attempts is programmed as = 5.

1. System receives alarm on Zone 1.
2. System attempts to communicate with the central station 5 times.
3. After fifth attempt, the system enters "FAIL TO COMMUNICATE" condition. Communicator shuts down, keypad annunciates fault condition.
4. Zone 1 restores. Still no communications.
5. Zone 2 trips. Five attempts will be made to transmit Zone 1 and Zone 2 alarm. Only if both Zones obtain successful transmission will system exit Fail To Communicate condition.

8.5 ANTI-JAM TIME (0-99 SECONDS)

To determine the Anti-Jam time for your telephone company central office, have someone dial the premises phone from another location. Instruct the caller to hang up immediately when the phone is picked up. The amount of time elapsed before dial tone is received is the Anti-Jam time. Once this time has been determined, program the Anti-Jam to exceed the time measured by two (2) to three (3) seconds.

NOTE: *Anti-Jam times vary from central office to central office.*

8.6 RESTORE ZONES (1-16)-(for REAL-TIME RESTORAL)

Select zones which will report restorals. A restore is defined as a return to normal after a zone has been previously tripped. If a burglary zone is tripped, a restore report will be transmitted when the zone restores. A Fire, Audible Panic, Silent, or a Silent Panic zone will transmit a restore report after the zone restores.

If Real Time Restoral is not desired, do not program any zones in this location.

8.7 ZONE REAL-TIME RESTORE CODE (2 DIGIT HEX)

Code used to report a restoral of a zone. The first digit is used to identify zones 1-8 and the second digit for zones 9-16.

EXAMPLE, PROGRAMMED ZONES:

Zone 1 Alarm code = 12 (Code from Item 25)
 Zone 9 Alarm code = 87 (Code from Item 25)
 Restore code = AB

Restore report in SK4+2 reporting format:

Zone 1 Restore code = A2
 Zone 9 Restore code = B7

8.8 TEST CANCEL ZONES (1-16)

Select zones which will report test cancels. If a test cancel zone is tripped and restored before the transmission of the alarm code, the Test Cancel Code will REPLACE the alarm code. On burglary zones, the Test Cancel will replace the alarm code only if the system is disarmed before transmission.

8.9 TEST CANCEL CODE (2 DIGIT HEX)

Code used to report a Test Cancel (See item 8). The first digit is used to identify zones 1-8 and the second digit for zones 9-16. Same assignment as item 7.

8.10 LOW BATTERY CODE (2 DIGIT HEX)

Code reported when a low battery voltage is detected. Refer to item 27 to enable this reporting feature and telephone number selection.

8.11 AC CODE (2 DIGIT HEX)

Code reported when AC power is lost. Refer to item 27 to enable this reporting feature and telephone number selection.

8.12 LOW BATTERY RESTORE CODE (2 DIGIT HEX)

Code reported when adequate backup system power (battery) is detected. Reports to the same telephone number as the low battery code.

8.13 AC RESTORE CODE (2 DIGIT HEX)

Code reported when AC power is reconnected. Reports to the same telephone number as the AC code.

8.14 TEST CODE (2 DIGIT HEX)

Code reported whenever a test signal is transmitted to the Central Station. Refer to item 27 to enable this reporting feature and telephone number selection. Refer to item 56 to set the reporting time.

NOTE: Test code is required when using the third telephone number for Uploading/Downloading Communications.

8.15 UPLOAD/DOWNLOAD CODE (2 DIGIT HEX)

Code reported after a successful transmission between the computer and system or system to system. Refer to item 27 to enable this reporting feature and telephone number selection.

8.16 BYPASS CODE (2 DIGIT HEX)

Code reported whenever the system is armed with a bypass zone. The first digit is used to identify zones 1-8 and the second digit for zones 9-16. Same assignment as item 7.

8.17 TROUBLE CODE (2 DIGIT HEX)

Code reported whenever a trouble condition is detected. First digit used to identify zones 1-8 while 2nd digit is used for zones 9-16. Same assignment as item 7.

8.18 EMERGENCY CODES (SINGLE DIGIT HEX)

Code reported whenever an emergency keypair is pressed. A total of four reports can be generated. If any extended format is used, these first digits will be followed by the keypad address programmed in location "0" of keypad programming. Refer to item 27 to enable this reporting feature and telephone number selection.

8.19 DURESS CODE (SINGLE DIGIT HEX)

Code reported during a duress report. To activate, press the "O" key after the access code, then press enter. The system will disarm and a silent alarm will be transmitted. Just as in the Emergency codes, the Duress code will be followed by the keypad address. Refer to item 27 to enable this reporting feature and telephone number selection.

8.20 CLOSING CODE (up to 4 total Hex digits)

NOTE: ITEM 24 MUST BE ENABLED TO TRANSMIT OPEN/CLOSE.

The Closing code can consist of 4 characters. If the optional features are not desired simply leave the 3rd or 4th digits blank.

[1&2] The first two digits are used for a standard Closing report, This is to inform the central station when the system has been armed. The first digit is used for user codes 1-15 and the second digit is for user codes 16-30. The identifiers are in Table 3 below.

TABLE 3 - DIGIT [1&2] CLOSE CODE

Program LOC #20	Location #20 = CE - USER NUMBER														
C	1	2	3	4	5	6	7	8	9	10	11	12	13	14	15
E	16	17	18	19	20	21	22	23	24	25	26	27	28	29	30
This is the First Digit Sent	1	2	3	4	5	6	7	8	9	A	B	C	D	E	F
	This is the Second Digit Transmitted														

USER #	1	2	3	4	5	6	7	8	9	10	11	12	13	14	15
Code sent	C1	C2	C3	C4	C5	C6	C7	C8	C9	CA	CB	CC	CD	CE	CF

USER #	16	17	18	19	20	21	22	23	24	25	26	27	28	29	30
Code sent	E1	E2	E3	E4	E5	E6	E7	E8	E9	EA	EB	EE	ED	EE	EF

If ScanPro were used to arm the system, the central station would receive a User 15 identifier. If this causes confusion, simply program the panel to also communicate Upload/Download and both signals will come in together. Using ScanPro to arm the panel would send the Close signal with User #33 to the Panel History.

[3] The third digit is used as the "Fail to Close" code. If the system is programmed for Open/Close by exception and the system is not armed within the "Close Window", then the "Fail-To-Close" code would be transmitted and precede the user identifier for **User 14** or an **"E"**.

[4] The fourth digit is used to enable the "Force Arm" report associated with the auto arming feature. When the system "auto arms" and a burglary zone is violated, the system will "Force Arm". When this occurs the fourth digit becomes the Force Arm reporting code that would precede the zone code identifiers. When or if the zones restore those zones become part of the armed system.

If Force Arm is desired without using the Fail-to-Close option, simply program the first two digits followed by a space which is followed by the Force Arm digit. As an example you could use **(CE 0)**.

Example: A code of **CE70** would generate the codes as below for users 1-30. The "Fail to Close" code would be a **7E** and the Self Arm would generate a **C8** at the assigned time. If zone **(5)** had a report code of 35 and it happened to be violated at the time of Auto Arm the system would generate a **05** report to the central station.

8.21 OPENING CODE (up to 4 total Hex digits)

NOTE: ITEM 24 MUST BE ENABLED TO TRANSMIT OPEN/CLOSE.

The Opening code can consist of 4 characters. If the optional features are not desired simply leave the 3rd or 4th digits blank.

[1&2] The first two digits are used for a standard Opening report, This is to inform the central station when the system has been disarmed. The first digit is used for user codes 1-15 and the second digit is for user codes 16-30. The identifiers are in Table 4 below.

TABLE 4 - DIGIT [1&2] OPEN CODE

Program LOC #21	Location #21 = BD - - USER NUMBER															
B	1	2	3	4	5	6	7	8	9	10	11	12	13	14	15	
D	16	17	18	19	20	21	22	23	24	25	26	27	28	29	30	
This is the First Digit Sent	1	2	3	4	5	6	7	8	9	A	B	C	D	E	F	
	This is the Second Digit Transmitted															

USER #	1	2	3	4	5	6	7	8	9	10	11	12	13	14	15
Code sent	B1	B2	B3	B4	B5	B6	B7	B8	B9	BA	BB	BB	BD	BE	BF

USER #	16	17	18	19	20	21	22	23	24	25	26	27	28	29	30
Code sent	D1	D2	D3	D4	D5	D6	D7	D8	D9	DA	DB	DD	DD	DE	DF

Again, if ScanPro were used to disarm the system, the central station would receive a User 15 identifier. If this causes confusion, simply program the panel to also communicate Upload/Download and both signals will come in together. Using ScanPro to disarm the panel would send the Close signal with User #33 to the Panel History.

[3] The third digit is used as the "Fail to Open" code. If the system is programmed for Open/Close by Exception and the system is not disarmed within the "open window" this signal will be sent to the central station. Whatever the digit is programmed for, it will be followed by the user **14** identifier, an **"E"**.

[4] The fourth digit is the "Conditional Opening" enable. Any digit in this position enables this feature. If enabled a conditional opening report code will be sent when the system has been disarmed after an alarm. **No other Opening Reports will be generated.** The identifier code will be used to identify the user. If Conditional Opening is desired without the Fail to Open option, simply program the first two digits followed by a space which in turn is followed by any digit. As an example you could use **(BD 2)**.

Note: Station reporting should not be used with Conditional Opening.

A code of **BD82** would generate the codes as below for users 1-30. The "Fail to Open" code would generate an **8E** and the **(2)** would enable the "Conditional Opening" feature.

8.22 STATION CODE (SINGLE DIGIT HEX)

This code and the keypad address (programmed in keypad memory location "0") is used to identify which keypad generated either an opening, closing, or emergency (duress) report.

Note: Station reporting should not be used with Conditional Opening.

8.23 STATUS CODE (2 DIGIT HEX)

Code reported to indicate that a previously reported zone is still violated. The first digit is used to identify zones 1-8 and the second digit for zones 9-16. Same assignment as item 7.

8.24 OPEN/CLOSE SELECTION BY E/E GROUP

(1 = GRP 1, 2 = GRP 2, 3 = GRP 3, 4 = GRP 4)

This feature enables the Open/Close reports to be communicated per partition. If all of the partitions are to report then 1, 2, 3 and 4 must be programmed for the O/C reports to communicate. In the same way, if selected partitions only are to communicate the appropriate partition numbers are to be programmed here.

NOTE: If partitioning is not used and O/C reports are desired this location must contain at least a one for partition (1).

8.25 ZONE REPORTING CODES (2 DIGIT HEX)

Code used to identify a particular zone. The first digit of this code will be REPLACED with the bypass, trouble, restore, status, and test cancel codes to identify the zone condition.

8.26 REPORTING ZONE SELECTION (1-16)

This programming function allows the user the flexibility to assign any zone to report to any phone number. If a zone is selected to report to receiver 1 and the report is not acknowledged by the central station (after two attempts), the system will transmit that report to phone number 2 (if a telephone number is programmed for receiver 2). If the system is unsuccessful at receiver 2 (after 2 attempts), it will alternate the reporting attempts between the first and second phone numbers until acknowledged or the maximum number of attempts has been reached. Zones selected for the second or third numbers will be transmitted to ONLY those phone numbers.

8.27 AUXILIARY CODE REPORT SELECTION (1-8)

Selection of which auxiliary codes are to be reported to which phone number. The code for the desired auxiliary code must also be programmed. Use the following chart to select which of the **seven** groups of items will report their code(s) to the assigned phone number.

1	Emergency Codes, Duress
2	Open, Close, Station
3	Zone Trouble, AC, Low Battery, Upload
4	History (For communications to ScanPro only)
5	Test Timer A
6	Test Timer B
7	Zone status, Bypass

EXAMPLE:

Sel #1 = 2,7 Reports Open,Close,Station, Zone status, and Bypass codes to phone # 1.

Sel #2 = 1 Reports Emergency and Duress codes on phone # 2.

Sel #3 = 4 Reports phone # 3.

Selecting 8 for each of the Phone Numbers is for three special optional items and are identified below:

For Phone #1	=Enable for Auto-Arm
For Phone #2	=Allows Incrementing of Account Number by Partition
For Phone #3	=Disables "Fail to Communicate" indication from keypad

8.28 ANSWER ON RING NUMBER (0-15)

The system may be programmed to automatically pickup and answer the telephone line after 1 to 15 rings. This function must be programmed if remote up/downloading is desired. If an answering machine is connected to the same phone line as the system, the system must be programmed for a minimum of 2 rings greater than the answering machine ring counter. A value of "0" will disable the ring detector.

8.29 EMERGENCY KEY BELL ENABLE (1-8)

If programmed, each emergency key pair can activate the burglary or fire output. In single bell operation, the Fire bell has priority. Use the following table to select type of operation. See Keypad Users Manual for details on use of emergency key pairs.

Key pair (1&3)	Burglary Bell	Key pair (1&3)	Fire Bell
	1		5
(4&6)	2	(4&6)	6
(7&9)	3	(7&9)	7
(*&#)	4	(*&#)	8

8.30 MISCELLANEOUS SYSTEM FUNCTION SELECT (1-8) - FUNCTION GROUP 1

Use the following chart to set the first system function group:

1	No EOL resistor	5	Zones 9-16 installed
2	Secure upload	6	2nd EEPROM INSTALLED
3	Installer privacy code	7	Latched fire bell
4	50 hertz AC	8	Bell shutoff any keypad

- When this feature is selected, only normally closed burglary zones can be used.
- When this feature is selected, the following Up/Download sequence is performed:
 - A Computer calls the remote system.
 - The remote system acknowledges the call then hangs up.
 - The remote system then calls back Computer (using the third telephone number) to perform the Up/Download operation.
- When this feature is selected and the P1 jumper (located on the system circuit board) is moved to "program" position, the Installers access code is NOT displayed (instead user 1 is displayed).
- Select this feature when the system is powered from 50 Hz AC source (i.e. European installations).
- Select this feature to enable zones 9-16.
- Select this feature if both EEPROMS are installed. The 2nd EEPROM is necessary when Zones 9-16 are installed, 32 user codes are used, or expanded history is desired.
- When this feature is selected, an access code must be used to shut-off the fire bell.
- When this feature is selected, users at any partition keypad may silence any alarm that occurs from the system.

8.30 MISCELLANEOUS SYSTEM FUNCTION SELECT (1-8) - FUNCTION GROUP 2

Use the following chart to set the second system function group:

1	Automatic bell test	5	Disable auto-scroll
2	Multi-premise	6	Disable ring back
3	Tone dial	7	1 & 3 for smoke reset
4	European rotary dial	8	Enable keypad tamper

- After the system is armed, the bell(s) turn on for approximately five seconds. This feature should not be used in a multi-premise installation.
 - Enable multi-premise operation.
 - Select this digit to enable Tone dialing. When this function is not programmed, the system defaults to rotary dialing.
 - Enable European rotary dialing (70 millisecond break and 30 millisecond make timing). If not programmed, the system defaults to standard 60/40 make break rotary dialing.
 - Select this feature to disable keypad status scrolling.
 - Disables ring back to acknowledge a successful transmission. Ring back is an output from the keypad and remote audible warning (remote audio piezo).
 - Select this digit to enable smoke reset from the keypad. To reset, press 1 & 3 simultaneously.
 - Select this digit to enable the keypad tamper switch. ******
- ** NOTE: This feature is only available for the European versions of the SC800/1600 panels. When selected, the [*&#] key pair alarm WILL NOT function.**

8.30 MISCELLANEOUS SYSTEM FUNCTION SELECT (1-8) - FUNCTION GROUP 3

Use the following chart to set the third system function group:

Most of the third function group selects, apply to the installation of optional remote Data Output Boards.

Use the following chart to set the third system function select groups.

- | | | |
|---|---|-----------------------------|
| 1 | Bell Module installed | (Data Output Board - DOB) |
| 2 | System status module installed | (Data Output Board - DOB) |
| 3 | Disable Exit Delay Annunciation | |
| 4 | Printer output installed | (Data Output Board - DOB) |
| 5 | Timer switch output, On | |
| | (Available off of DOB or Assignable Output) | |
| 6 | Keypad switched output, On | |
| | (Available off of DOB or Assignable Output) | |
| 7 | Computer controlled output 1, On | |
| | (Available off of DOB or Assignable Output) | |
| 8 | Computer controlled output 2, On | (Available off of DOB only) |

1 Set this digit to enable the Bell Module **DOB**. The bell module contains the following outputs:

- * Four Area Controlled burglary bell outputs. Outputs 1-4 are assigned to keypads 1-4 respectfully.

EXAMPLE 1:

If zones 1, 2, 3 are assigned to keypad 1, then ONLY these zones will activate bell module output 1. And if zones 5,6,7 are assigned to keypad 3, then ONLY these zones will activate bell module output 3.

EXAMPLE 2:

Keypad 1 was assigned zones 3,4, and 5, and user 2 was assigned zones 3 and 4. Bell 1 was activated by zone 5, since user 2 was not assigned zone 5 he cannot deactivate bell 1 at keypad 1 unless item 30 part 1 is programmed with an eight – Silence All Area Bells.

- * One Non-pulsing Fire Bell output.
- * One Smoke Reset output which is active at the same time and duration as the system smoke power output.
- * One Door Strike output. To enable this output, the proper user attribute must be selected (refer to item 67).
- * One Strobe Output. Acts similar to the burglary bell output, except that there is no auto shut off. An access code is required to reset the strobe.

2 Select this digit to enable the System Status Module **DOB**. The Status Module Contains the following outputs:

- * AC Fail output.
- * Switched timer output. The output time and duration of this timer are programmed in items 31 and 32. This output could be used to turn on an outside light, activate a sprinkler system, or any other timer controlled function.
- * Keypad activated output. This remote output is activated at any keypad with the following key sequence: [PPPP] [*] [1&2] [4 0] [#]. To turn off this output, use the following key sequence: [PPPP] [*] [1&2] [4 1] [#]
- * 2 Computer Controlled outputs, PC Output 1 and Output 2.
- * Low Battery condition output.
- * Fail to Communicate output.
- * Zone Trouble output

- 3 Select this digit to disable keypad annunciation during exit delay.
- 4 Select this digit to enable the printer **DOB** module.
- 5 Select this digit to enable the timer output on the system status module or Assignable Output.
- 6 Select this digit to enable the keypad activated output on the system status module or Assignable Output.
- 7 This digit enables the computer controlled output (1) (located on the system status module) or Assignable Output.
- 8 This digit enables the computer controlled output (2) (located on the system status module).

8.31 REMOTE CONTROL TIMER

This timer sets the time of day when the timer output (located on the system status module) is active. Refer to item 32 for the output duration.

8.32 REMOTE CONTROL TIMER DURATION (1-95)

Remote control window (1-95) controls how long the remote control outputs are active (15 minute increments). At a setting of 95 the duration is at maximum duration of 23.75 hours.

Caution: Values set in excess of 95 will cause errors.

8.33 ASSIGNABLE OUTPUT

This output may be programmed to provide +12.5 V.D.C at terminal 8 whenever the selected condition occurs. Program as follows:

FUNCTION	PROGRAM ENTRY
0 Burglar Bell	6 Ready/Trouble
1 Arm/disarm	7 Audible warning
2 Door Strike	8 Courtesy
3 Strobe light	9 Switched output (timer)
4 Fail to Comm.	10 Switched output (keypad)
5 Arm/disarm/alarm	11 Computer switched output

8.34 FALSE ALARM SHUTDOWN COUNT

This function sets the amount of times the system will allow the zone to report alarm or trouble condition (within a 2-3 hour period), before automatically stopping any further communication from the zone. Each zone has its own count with a range of 0 - 16. If a value of "0" is entered, the zone will never shut down. The count is renewed after 24 hours, by the activation of another zone, or after disarming the system. Alarm, restore, or trouble conditions are included in the shut down count.

8.35 PROGRAMMABLE ZONE RESPONSE SELECT

Select the zones that require a different response time when the system default of 300mS (approx 1/3 of a second) has to be changed. The response time for these zones is programmed in item 36.

8.36 ZONE RESPONSE TIME (0-99)

The amount of time that must elapse before the system recognizes a zone trip. The response time can be set from 10 to 500 milliseconds. Time = (2 + value) x 5 milliseconds.

EXAMPLE: 5 is entered, (2+5) x 5ms = Zone response = 35 milliseconds

NOTE: *Zone response times of less than 300mS are susceptible to false alarms. Care must be taken when used.*

8.37 SILENT 24 HOUR PANIC ZONES (1-16)

Select zones to be programmed for silent panic. Whether the panel is armed or disarmed, the system or keypad will not announce an alarm condition on a silent zone.

8.38 AUDIBLE 24 HOUR PANIC ZONES (1-16)

Select zones to be programmed for audible panic. Zones selected for audible panic are always armed unless bypassed.

8.39 AUDIBLE 24 HOUR FIRE ZONES (1-16)

Select zones to be programmed for audible fire. Zones selected for audible fire are always armed.

NOTE: IT IS STRONGLY RECOMMENDED THAT FIRE ZONES NOT BE ENABLED FOR BYPASS.

8.40 AUDIBLE BURGLARY ZONES (1-16)

Select zones to be programmed for audible burglary. These zones are on when armed and not bypassed. If you wish a zone to be Silent Burglary, program the zone in Item 40 and in Item 37.

8.41 ENTRANCE/EXIT ZONES (1-16)

Select zones to be programmed for Entrance/Exit delay.

NOTE: *These zones must be programmed for audible burglary.*

8.42 ZONE DELAY GROUP SELECTION (1-16)

There are four (4) exit/entrance delay times available. These may be used independently for partitioning, multi-premise, or separate times for front and back doors. Select all delay burglar and associated follower zones for each delay group. A follower zone is enabled by assigning a zone to a zone delay group, without assigning that zone as an entry/delay zone.

8.43 ENTRANCE DELAY TIMES (1-15)

Four (4) entrance delay times are available. Each programmable from 10 to 150 seconds in 10 second increments. Unprogrammed value equals zero (0).

8.44 EXIT DELAY TIMES (1-15)

Four (4) exit delay times are available. Delay times programmable from 10 to 150 seconds in 10 second increments. Unprogrammed

value equals zero (0).

8.45 REPORTING DELAY ZONES (1-16)

Select the zones which will delay before dialing out to the receiver. If an alarm signal on a 24-Hour delay zone restores prior to expiration of the delay time, the zone will not report out. But, audible and silent zones will latch until the system is reset. For burglary zones, the panel must be disarmed during the delay in order to abort the report.

8.46 ZONE REPORTING DELAY

Time in seconds the panel will wait before seizing the telephone line. If the zone is reset prior to the expiration of delay time, the report will be aborted. The delay value in increments of 10 seconds.

8.47 TROUBLE REPORTING ZONES (1-16)

Fire and Burglary zones selected to report a trouble condition. Burglary zones will report trouble when violated while disarmed. Fire zones report trouble when an open in a fire loop is detected. Reporting Code selected in memory location 17 will be reported.

8.48 DAY/NIGHT ZONE (1-16)

Burglary zones may be selected to display trouble conditions. Fire zones are automatically enabled to display trouble. Burglary zones indicate trouble when violated while disarmed.

8.49 BYPASS ZONES (1-16)

Select those zones allowed to be bypassed. A bypassed zone is a disabled zone when the system is armed.

NOTE: IT IS STRONGLY RECOMMENDED THAT FIRE ZONES NOT BE ENABLED FOR BYPASS.

8.50 CHIME ZONES (1-16)

Any combination of zones may be selected for chime. The keypad will briefly announce when a chime zone is violated (zone must be disarmed) and again when the zone restores.

NOTE: *These zones must be programmed for burglary operation.*

8.51 INTERIOR ZONES (1-16)

If desired, bypassable zones can be grouped together to allow bypassing with a minimum amount of keystrokes. Item 51 allows two different bypass groups with any zone(s) combination.

EXAMPLE 1: Group 1 - Zones 1, 2, 3, 4
Group 2 - Zones 9, 10, 11, 12

To bypass group 1, use key sequence:
"[USER CODE] [*] [1] [#]" bypasses zones 1, 2, 3, 4 .

To bypass group 2, enter key sequence:
"[USER CODE] [*] [2] [#]" bypasses zones 9, 10, 11, 12.

EXAMPLE 2: In a single family dwelling with Zones 1, 2, 3, 4 protecting the interior of the dwelling, and zones 5, 6, 7, 8 protecting its exterior, Group 1 can be set to 1, 2, 3, 4. This allows the owner (with a minimum of keystrokes) to arm the exterior and bypass the interior of the dwelling. This also frees the user from having to remember all interior zones and inadvertently bypass an exterior zone.

8.52 ZONES ASSIGNED TO KEYPAD

This programming function allows the flexibility to assign any zone(s) to any keypad(s). Assigning zones to keypads performs two functions. The keypads will only display the status of the zones that are assigned to that keypad. Remember that in partitioning using common zone(s) do not assign common zones to any keypad.

Example, if keypad 2 is assigned zones 2, 3, and 4, and zone 5 is violated, keypad 2 will NOT display the status of zone 5. The second purpose of this assignment is to control the four area bells (these bell outputs are located on the status module, see item 30 group 3). Zones assigned to keypad areas 1-4 will activate bell module outputs 1-4 respectively.

8.53 ZONE DESCRIPTIONS (16 CHARACTERS EACH)

Program a description of each zone. See the keypad programming insert for entering letters and special characters.

8.54 BELL SHUT OFF TIME (1-15)

The length of time (in minutes) the bell will remain on when the automatic bell shutoff feature is used. The value entered is multiplied by 2 (maximum time = 30 minutes).

8.55 AC/LOW BATTERY REPORT DELAY (1-15)

Time in minutes that a low battery or AC report will be delayed. If the condition is corrected during the delay time, the report will be aborted. The audible trouble indication is also delayed by this amount of time. Unprogrammed value equals zero (0), (maximum time = 15 minutes).

8.56 TEST TIMER REPORTING TIME

Two independent test timers are available and can be programmed to report the Test Code to any receiver. These timers can be programmed to report 24 hours from the last report or on a daily, weekly, monthly, or yearly cycle and at a predetermined time of day. Leave these locations blank to report 24 hours from the last report. If a predetermined time is desired, set the hour and minute in the same manner as setting the system time, then set the cycle that the report is to occur. Programming only the time will result in daily reports. Programming the day of week will result in the test report being transmitted on that weekday at the time programmed. Do not program a month or day for weekly reports. Programming a day of month will result in monthly reports and programming a month and day of month will yield a yearly report. Each timer is independent and any combination of report cycles may be programmed.

8.57 START TIME FOR OPENING REPORT EXCEPTION WINDOW

Opening/Closing by Exception is a cost saving feature which reduces the amount of reports. When a Exception Window time is specified, arming/disarming during this period will not activate a report; arming/disarming outside this time window will activate an Opening or Closing report. Even though no Opening/Closing reports are issued during Exception time, the event is still saved in history. Enter the time of day that you want to start opening by exception. Refer to item 59 for the opening time duration.

8.58 START TIME FOR CLOSING REPORT EXCEPTION WINDOW (optional AUTO-ARM time)

Enter the time of day that you want to start the closing by exception window. Refer to item 59 for closing time duration. (See item 57 for description and item 61 for examples). Two minutes prior to the expiration of the closing window, the keypad will annunciate and display the message:

```
.. TIME TO CLOSE .
```

To extend the closing window by an additional fifteen (15) minutes, enter the following sequence:

```
[PPPP] [*][9][#]  
Pass Code
```

This sequence can be repeated fifteen (15) times or accumulated to 12:00 am (midnight), whichever comes first.

This location is where the time is to be programmed at which the Auto-Arm will occur if enabled in Step 27.

8.59 EXCEPTION WINDOW (1-15)

Enter the time duration desired for the open/closing by exception. The value entered is multiplied by 15 minutes. (A range of 15 to 225 minutes is allowed). Refer to item 61 for examples.

8.60 EXCEPTION DAYS

An exception day is a day of the week that normal open/closing reports are not expected (i.e., Saturday and Sunday). If an opening or closing occurs (no matter what time of day), a report will be generated. On non exception days (the normal work week - Monday through Friday), an opening or closing report will only be generated if the opening or closing occurs outside the designated window. Enter the days of the week that opening and closing by exception are not desired. (Sunday = 1 Monday = 2 Saturday = 7).

8.61 HOLIDAY SCHEDULE

Up to ten holidays may be selected. Holidays used in conjunction with Opening/Closing by Exception further define the Opening/Closing schedule. These days are during the week when an Opening/Closing is not anticipated. If the system is opened/closed on a holiday, the system will report an Opening/Closing report.

EXAMPLE SETUP:

Items

57 (Start of Opening by Exception Time = 8:00 AM)	
58 (Start of Closing by Exception Time = 5:00 PM)	
59 (Exception Window = 2 (30 minutes))	
60 (Exception Schedule = 1 and 7 (Sat and Sunday))	
61 (Holiday Schedule = 12-25 (December 25th))	

Example 1. User opens (disarms) on Monday at 8:05 AM and closes (disarms) at 5:23 PM - No report is issued.

Example 2. User opens on Saturday at 8:05 AM. System sends an Opening report.

Example 3. User opens on Sunday at 8:05 AM. System sends an Opening report.

Example 4. User opens on Monday, December 25 at 8:05 AM. System sends an Opening report.

Example 5. User opens on Wednesday 8:25 AM - No report is issued. User opens on Wednesday 8:30- an Opening report is issued.

8.62 PANEL PASSWORD

This security code is required to enable computer to panel or panel to panel communications. Refer to Item 63.

8.63 FEATURE NO LONGER USED

8.63 INSTALLER CODE

A four digit code used to provide access to the installer level of programming.

8.64 ABBREVIATED ARMING DIGIT LENGTH

Enter number of digits for abbreviated arming codes. Full passcode is required for disarm of the system.

8.65 USER PASS CODES

Up to 16 user codes can be programmed in the first EEPROM. Another 16 can be added with a second EEPROM. Each pass code must be four digits in length. These codes will access the system features as described in item 67 (users attributes).

8.66 USER ATTRIBUTES (1-8)

This programming feature allows the installer to enable/disable system functions for each user. Enter function(s) for each user from the chart below:

1 INHIBIT VIEW HISTORY	5 NO EE/ZONE DESCRIPTION
2 DOOR STRIKE	6 NO USER PROGRAMMING
3 ARMING ONLY	7 CHANGE OWN CODE ONLY
4 NO BYPASS CAPABILITY	8 USER GROUP BOUNDARY

- 1 Users assigned this feature are unable to view history.
- 2 Users assigned to this feature can activate the door strike of the assignable output or data output boards. When assigning Door Strike to a particular user, Do Not assign that user any zones to control. (Item 68 - Zones Assigned to User).
- 3 Users assigned to this feature can only arm the zones assign to their code.
- 4 Even if bypassable zones are assigned to this user, this user cannot disable those zones.
- 5 This user cannot change the zone description or entry exit times.
- 6 This user cannot change any user level programming features (i.e. change time/of/day, zone descriptions, EE times).
- 7 The only function this user can perform is changing their own pass code.
- 8 This digit identifies the first user of the second, third, and fourth partitions.

EXAMPLE:

If users 5,17, and 19, have an "8" programmed, users 1-4 are assigned to group 1, users 5-16 are assigned to group 2, users 17 and 18 are assigned to group 3, and users 19-32 are assigned to group 4.

Note: Leaving this location blank gives the user access to all user level features.

8.67 ZONES ASSIGNED TO USER (1-16)

This programming feature assigns zone(s) to each user. Each user can only control the zones assigned to them. Remember when partitioning and using common zones, to assign the zones to appropriate users.

EXAMPLE: User 1 zones 1, 9, 15
User 2 zones 1 through 16

User 2 can arm/disarm all zones but, user 1 can only arm/disarm zones 1, 9, 15. When this code is used for disarming, the zones would indicate a "Bypassed" status.

SECTION 9: UL COMPLIANCE

9.1 RESIDENTIAL UL GRADE A

Follow the instruction below for compliance to:

- Household Fire Warning System Units (UL985)
- Household Burglary-Alarm System Units (UL1023)
- Communicator System Units (UL1635)

HARDWARE CONSIDERATIONS

1. Do not plug the Basler transformer into a receptacle controlled by a switch.
2. All burglary zones must be terminated by a 2200 ohm 1/2 watt resistor which is included with each unit. (P/N 123-000222).
3. All Fire type zones of protection must be terminated with an end-of-line module which is sold separately (P/NEOL2200).
4. Use only UL listed 4-wire smoke detectors and EOL relay modules. If the FM2000 is used, use a listed two-wire smoke detector indicated in the FM2000 Installation manual.
5. Use only UL listed bell or siren drivers. Maximum current for the bell output should not exceed 300mA. Use terminals 7 and 9 as the bell output and use the single bell mode.
6. Maximum combined current draw for Auxiliary, Fire, Keypad, and Auxiliary status outputs (Arm, Ready, Aud. Warning, and Courtesy) is 600mA.
7. Use a Yuasa 12 volt 6 or 7AH battery. (Yuasa NP6-12 or NP7-12).
8. When using the courtesy output, use only UL listed burglary alarm interface modules. Suggested module: X10 BA-284.
9. If using the keyswitch input, use only UL listed momentary key switches.
10. Keypads must be installed within the protected area.
11. A UL listed tamper switch must be installed on the control panel cabinet.
12. UL listed SC800 Accessories:
 - EKP1 LED Keypad - Current draw=100mA
 - SK1L LCD Keypad - Current draw=100mA
 - EEM-8 zone expander
13. Use only UL listed annunciators for the Audible warning output.
14. Cut Jumper JPO.

PROGRAMMING CONSIDERATIONS

[] = Programming sheet locations

1. Maximum Exit time allowed is 60 seconds.
2. Maximum Entry time allowed is 40 seconds.
3. *Do not use the Auto-Arming feature in certified installations.*
4. Program the panel to report to the Central Station on loss of AC power and Low Battery. [Item 11 and 12]
5. Program all alarm sounding devices to operate for a minimum of 4 minutes [Item 54]
6. Program the panel to report all Fire zone trouble conditions to the Central Station [Item 47]
7. Dialing attempts for phone 1 & 2 must be a minimum of 5 and a maximum of 10 attempts. [Item 4]
8. Program the (1 & 3) key pair for "Fire Power Reset". [Item 30.2]
9. Test message interval must be programmed to 1 every 24 hours. [Item 30.2]
10. Single bell operation must be programmed in order to get a pulsing output for Fire and a constant output on burglary violations. [Item 33 - program anything other than 0]
11. Manual shutdown for fire zones (Latch Fire Bell operation) must be enabled. [Item 30.1]

12. For correct dialer report prioritizing, Fire zones are to be assigned to the lowest numbered zones, Panics on the next numbered zones, and burglary zones on the highest numbers. Example: Zone 1 = Fire, Zone 2 = Panic, Zones 3-8 = Burglary.

9.2 COMMERCIAL USE OF THE SC1600L

Note: *Only the SC1600 Control Panel is suitable for use in Commercial Burglary installations. Its Grade A Cabinet that it comes standard with, complies with the UL requirements below.*

Follow the instruction below for compliance to:

- Grade A Police Connected Mercantile Premises Alarm System / Safe & Vault (UL 365)
- Grade A Local Mercantile Premises Alarm System / Safe and Vault Alarm System. (UL 609)
- Digital Alarm Communicator System Units. (UL 1635)

HARDWARE CONSIDERATIONS

1. Do not plug the Basler transformer into a receptacle controlled by a switch.
2. All burglary zones must be terminated by a 2200 ohm 1/2 Watt resistor which is included with each unit. (P/N 123-000222).
3. All fire type zones of protection must be terminated with an end-of-line module which is sold separately. (P/N EOL2200).
4. Use only UL listed 4-wire smoke detectors and EOL relay modules.
5. Use only UL listed bell or siren drivers and Grade A Bell housing for commercial installations. Maximum current for the bell output should not exceed 300mA. Suggested bells: Wheelock MD-G10-12-R. Suggested bell housing: Ademco model AB12.

Note: *The bell in the Ademco AB12 must be removed a replaced with the Wheelock bells to stay within the 300mA bell rating. Some drilling may be required to mount the new bell. The two tamper switches and the inner housing tamper of the AB12 must be used.*

6. Maximum combined current draw for Auxiliary, Fire, Keypad, and Auxiliary status outputs (Arm, Ready, Aud. Warning, and Courtesy) is 500mA.
7. Use a Yuasa 12 volt 18AH battery. (Yuasa (NPG18-12).
8. When using the Courtesy output, used only UL listed burglary alarm interface modules. Suggested module: X-10 BA-284.
9. If using the keyswitch input, use only UL listed momentary keyswitches. An SK1L keypad must be used in conjunction with the keyswitch.
10. UL listed SC1600 Accessories:
 - SK1L LCD keypad - Current draw = 100mA Max.
 - EKP1 keypad - Current draw = 100mA Max.
 - EEM-8 zone expander.
11. Use only UL listed annunciators for the Audible warning output.
12. Cut jumper JPO.
13. Use the commercial grade Enclosure (included with the SC1600).

14. UL listed tamper switches must be added to the enclosure to detect removal from the mounting surface and removal of the lid.

PROGRAMMING CONSIDERATIONS

[] = Programming sheet locations

1. Maximum Exit time allowed is 60 seconds.
2. Maximum Entry time allowed is 40 seconds.
3. *Do not use the Auto-Arming feature in certified installations.*
4. Program the panel to report to the Central Station on loss of AC power and Low Battery. [Item 11 and 12].
5. Program all alarm sounding devices to operate for a minimum of 15 minutes. [Item 54].
6. Program the panel to report all Fire zone trouble conditions to the Central Station. [Item 47].
7. Dialing attempts for phone 1 & 2 must be a minimum of 5 and a maximum of 10 attempts. [item 4].
8. Program the (1 & 3) key pair for "Fire Power Reset". [Item 30.2].
9. Test message interval must be programmed to 1 every 24 hours. [item 56].
10. Single bell operation must be programmed in order to get a pulsing output for fire and a constant output on burglary violations. [Item 33 - program anything other than 0]

11. Manual shutdown for fire zones (Latch Fire Bell operation) must be enabled. [Item 30.1].
12. For correct dialer report prioritizing, Fire zones are to be assigned to the lower numbered zones, Panics on the next lowest numbered zones, and burglary zones on the highest numbers. Example: Zone 1 = Fire, Zone 2 = Panic, Zone 3-8 = Burglary.
13. System must be programmed to automatically test the sounding device upon arming. [Item 30.2].

ADDITIONAL NOTES

1. Regular Maintenance inspections shall be provided at least once a year (UL 365, 609).
2. A Power Sonic 12 volt 8AH battery (Model PS-1282L) must be used in order to achieve a 24 hour battery back-up time. Maximum current draw from the Auxiliary and Bell outputs are as follows:
Auxiliary, Fire, Keypad, Arm, Ready, Aud. Warning, and Courtesy Output = 175mA. Bell output = 300mA.

SECTION 10: COMPLIANCE

INFORMATION TO USER

This equipment has been tested and found to comply with the limits for Class B digital device, pursuant to part 15 of FCC rules. These limits are designed to provide reasonable protection against harmful interference in a residential installation. This equipment can radiate radio frequency energy and, if not installed and used in accordance with the instructions, may cause harmful interference to radio communications. However, there is no guarantee that interference will not occur in a particular installation. If this equipment does cause harmful interference to radio or television reception, which can be determined by turning the equipment off and on, the user is encouraged to try to correct the interference by one or more of the following measures:

1. Reorient or relocate the receiving antenna.
2. Increase the separation between the equipment and receiver.
3. Connect the equipment into an outlet on a circuit different from that to which the receiver is connected.
4. If necessary, the user should consult the alarm dealer or a experienced radio/television technician for additional suggestions. The user may find the following booklet prepared by the Federal Communications Commission helpful, "How to Identify and Resolve Radio-TV Interference Problems." This booklet is available from the U.S. Government Printing Office - Washington, DC, 20402, Stock #004-000-00345-4.

FCC COMPLIANCE

This equipment complies with Part 68 of the FCC Rules. On the bottom of this equipment is a label that contains, among other information, the FCC Registration Number and Ringer Equivalence Number (REN) for this equipment. You must, upon request, provide this information to your telephone company.

The REN is useful to determine the quantity of devices you may connect to your telephone line and still have all of this devices ring when your telephone number is called. In most, but not

all areas, the sum of the REN's of all devices connected to one line should not exceed five (5.0). To be certain of the number of devices you should contact your local telephone company to determine the maximum REN for your calling area.

If your telephone equipment causes harm to the telephone network, the Telephone Company may discontinue your service temporarily. If possible, they will notify you in advance, but if advance notice is not practical, you will be notified as soon as possible. You will be informed of your right to file a complaint with the FCC.

Your telephone company may make any changes in its facilities, equipment, operations or procedures that could affect the proper functioning of your equipment. If they do, you will be notified in advance to give you an opportunity to maintain uninterrupted telephone service.

If you experience trouble with this telephone equipment, please contact Sentrol, Inc. P.O. Box 2904, Hickory, N.C. 28601, for information on obtaining service or repairs. The telephone company may ask that you disconnect this equipment from the network until the problem has been corrected or until you are sure that the equipment is not malfunctioning.

This equipment may not be used on coin service provided by the telephone company. Connection to party lines is subject to state tariffs.

This device requires a USOC RJ31X jack.

Caution:

Changes or modification not expressly approved by Sentrol, Inc., could void the user's authority to operate the equipment.

SECTION 11: CANADIAN INSTALLATIONS

NOTE: The Canadian Department of Communications label identifies certified equipment. This certification means that the equipment meets certain telecommunications network protective, operational and safety requirements. The Department does not guarantee the equipment will operate to the user's satisfaction.

Before installing the equipment, users should ensure that it is permissible to be connected to the facilities of the local telecommunications company. The equipment must also be installed using an acceptable method of connection. In some cases, the company's inside wiring associated with a single line individual service may be extended by means of a certified connector assembly (telephone extension cord). The customer should be aware that compliance with the above conditions may not prevent degradation of service in some situations.

Repairs to certified equipment should be made by an authorized Canadian maintenance facility designated by the supplier. Any repairs or alterations made by the user to this equipment, or equipment malfunctions, may give the telecommunications company cause to request the user to disconnect the equipment.

Users should ensure for their own protection that the electrical ground connections of the power utility, telephone lines and internal metallic water pipe system, if present, are connected together. This precaution may be particularly important in rural areas.

CAUTION: Users should not attempt to make such connections themselves, but should contact the appropriate electric inspection authority, or electrician as appropriate.

The Load Number (LN) assigned to each terminal device denotes the percentage of the total load to be connected to a telephone loop which is used by the device to prevent overloading. The termination on the loop may consist of any combination of devices subject only to the requirements that the total of the Load Numbers of all the devices does not exceed 100. The load number for this equipment is LN = 2.

AVIS: L'étiquette du ministère des Communications du Canada identifie le matériel homologué. Cette étiquette certifie que le matériel est conforme à certaines normes de protection, d'exploitation et de sécurité des réseaux de télécommunications. Le Ministère n'assure toutefois pas que le matériel fonctionnera à la satisfaction de l'utilisateur.

Avant d'installer ce matériel, l'utilisateur doit s'assurer qu'il est permis de le raccorder aux installations de l'entreprise locale de télécommunication. Le matériel doit également être installé en suivant une méthode acceptée de raccordement. Dans certains cas, les fils intérieurs de l'entreprise utilisés pour un service individuel à ligne unique peuvent être prolongés au moyen d'un dispositif homologué de raccordement (cordon prolongateur téléphonique

interne). L'abonné ne doit pas oublier qu'il est possible que la conformité aux conditions énoncées ci-dessus n'empêche pas la dégradation du service dans certaines situations. Actuellement, les entreprises de télécommunication ne permettent pas que l'on raccorde leur matériel à des jacks d'abonné, sauf dans les cas précis prévus par les tarifs particuliers de ces entreprises.

Les réparations de matériel homologué doivent être effectuées par un centre d'entretien canadien autorisé désigné par le fournisseur. La compagnie de télécommunications peut demander à l'utilisateur de débrancher un appareil à la suite de réparations ou de modifications effectuées par l'utilisateur ou à cause de mauvais fonctionnement.

Pour sa propre protection, l'utilisateur doit s'assurer que tous les fils de mise à la terre de la source d'énergie électrique, des lignes téléphoniques et de canalisations d'eau métalliques, s'il y en a, sont raccordés ensemble. Cette précaution est particulièrement importante dans les régions rurales.

AVERTISSEMENT. - L'utilisateur ne doit pas tenter de faire ces raccordements lui-même; il doit avoir recours à un service d'inspection des installations électriques, ou à un électricien, selon le cas.

L'indice de charge (IC) assigné à chaque dispositif terminal indique, pour éviter toute surcharge, le pourcentage de la charge totale qui peut être raccordée à un circuit téléphonique en boucle utilisé par ce dispositif. La terminaison du circuit en boucle peut être constituée de n'importe quelle combinaison de dispositifs, pourvu que la somme des indices de charge de l'ensemble des dispositifs ne dépasse pas 100.

L'indice de charge de cet produit est 2.

This digital apparatus does not exceed the Class B limits for radio noise emissions from digital apparatus as set out in the radio interference regulations of the Canadian Department of Communications.

Le présent appareil numérique n'émet pas de bruits radioélectriques dépassant les limites applicables aux appareils numériques de Classe B prescrites dans le règlement sur le brouillage radioélectriques édicté par le Ministère des Communications du Canada.

SECTION 12: LIMITED WARRANTY

WARRANTY AND LIABILITY LIMITATIONS AND DISCLAIMER

LIMITED WARRANTY

Sentrol, Inc., warrants to the purchaser that under normal use and service, its control panel products will be free from defects in material and workmanship for twenty-four (24) months from the date of manufacture of the products and that its motion detecting sensors will be free from defects in material and workmanship for sixty (60) months (5 Years) from the date of manufacture of the product. Sentrol, Inc.'s warranty obligation is limited to repairing or replacing (at Sentrol, Inc.'s sole option) equipment which has been, during the warranty period and not more than thirty (30) days after discovery, reported to Sentrol, Inc., as defective in material or workmanship and is so found to be by Sentrol, Inc., upon inspection. For the purposes of this Warranty, Purchaser refers to wholesale purchaser, installer and retail purchaser. **RETAIL PURCHASER MUST, HOWEVER, IN THE CASE OF DEFECT, CONTACT THE PERSON OR ENTITY WHO INSTALLED AND MAINTAINS THE PRODUCT WHO IN TURN SHOULD CONTACT SENTROL, INC., IN ACCORDANCE WITH THE TERMS OF THIS LIMITED WARRANTY.**

Examination and repair or replacement of such equipment will, be performed at Sentrol, Inc.'s facilities located in Hickory, North Carolina with no charge to purchaser for service time expended, except as otherwise stated in this Warranty Limitations and Disclaimer. Equipment to be examined, replaced or repaired at Sentrol, Inc.'s facilities must be returned to Sentrol, Inc., by purchaser within the warranty period, insurance and transportation charges prepaid. Prior to the return of the equipment, wholesale purchasers or installers shall obtain a return authorization number from Sentrol, Inc.'s Customer Service Department. Retail purchasers are to contact the person or entity who installed and maintains the product. Under no circumstance will Sentrol, Inc., be responsible for expenses or labor incurred in removing and reinstalling its products from the retail purchaser's location. If examined equipment is found not to be defective or is not for some other reason within the warranty coverage, Sentrol, Inc.'s service time expended will be charged to purchaser.

Purchaser shall be responsible for all maintenance, service, replacing expendable parts, making minor adjustments and performing operating checks, all in accordance with procedures outlined in Sentrol Inc.'s Owners, Installation, and Programming manuals. This Warranty shall not apply to any product failure that results from purchaser's failure to properly maintain, service, adjust, inspect and test the product in accordance with Sentrol, Inc.'s Owners, Installation, and Programming manuals.

WARRANTY LIMITATION AND EXCLUSION

The repair or replacement of any product under this Warranty Limitation and Disclaimer shall in no event extend the term of the warranty beyond the original term set forth herein.

Sentrol, Inc., will have no further warranty obligation under this agreement if the equipment is subject to tampering, abuse, misuse, electronic disruption, negligence, accident, flood, fire, acts of God, improper installation, application or programming, improper maintenance or repair, alteration, repair or installation by an unauthorized installer or repair facility, improper storage, transportation or handling, or if purchaser fails to perform any of the procedures set forth in the manuals, specifically, the equipment must have been installed in accordance with the instructions and operated in accordance with the instructions found in the Owner's, Installation, and Programming Manuals and operated in accordance with such instructions. In particular, the unit must be programmed for regular test and the tests must be conducted on a regular basis, but no less often than once per week.

This Warranty does not apply to components or parts manufactured by any person or entity other than Sentrol, Inc.

Any repair or replacement of product within this Warranty must be performed by Sentrol, Inc.

DISCLAIMER OF WARRANTIES

THE WARRANTY PRINTED ABOVE IS THE ONLY WARRANTY APPLICABLE TO THIS PURCHASE. ALL OTHER WARRANTIES, EXPRESSED OR IMPLIED, INCLUDING, BUT NOT LIMITED TO, THE IMPLIED WARRANTY OF MERCHANTABILITY AND FITNESS FOR A PARTICULAR PURPOSE ARE DISCLAIMED.

NO OTHER PERSON OR ENTITY HAS BEEN AUTHORIZED BY SENTROL, INC., TO MODIFY OR CHANGE THE TERMS OF THIS WARRANTY. ANY AFFIRMATION OF FACT OR PROMISE MADE TO THE PURCHASER WHICH RELATES TO THE GOODS SOLD UNDER THIS AGREEMENT SHALL NOT BE REGARDED AS A PART OF THE BASIS OF THE BARGAIN AND SHALL NOT BE DEEMED TO CREATE AN EXPRESS WARRANTY THAT THE GOODS SHALL CONFORM TO THE AFFIRMATION OR PROMISE. ANY DESCRIPTION OF THE GOODS SOLD UNDER THIS AGREEMENT SHALL NOT BE REGARDED AS A PART OF THE BASIS OF THE BARGAIN AND SHALL NOT BE DEEMED TO CREATE AN EXPRESS WARRANTY THAT SUCH GOOD SHALL CONFORM TO THE DESCRIPTION.

SENTROL, INC., DOES NOT WARRANT THAT THE PRODUCT WILL MEET OR COMPLY WITH THE REQUIREMENTS OF ANY SAFETY CODE REGULATION, STATUTE OR ORDINANCE OF ANY STATE, MUNICIPALITY OR OTHER JURISDICTION.

LIMITATION OF LIABILITY

SENTROL, INC., DOES NOT, BY WAY OF THIS LIMITED WARRANTY OR IN ANY OTHER MANNER, WARRANT OR GUARANTEE THAT THIS PRODUCT WILL PREVENT PERSONAL INJURY OR PROPERTY LOSS. PURCHASER SHOULD TAKE ALL REASONABLE AND AVAILABLE PRECAUTIONS IN PROTECTING HIS OR HER SAFETY. IT IS UNDERSTOOD AND AGREED THAT SENTROL, INC.'S LIABILITY WHETHER IN CONTRACT, IN TORT, UNDER ANY WARRANTY, IN NEGLIGENCE OR OTHERWISE, SHALL NOT EXCEED THE RETURN OF THE AMOUNT OF THE PURCHASE PRICE PAID BY PURCHASER AND UNDER NO CIRCUMSTANCES SHALL SENTROL, INC., BE LIABLE FOR SPECIAL, INDIRECT OR CONSEQUENTIAL DAMAGES. THE PRICE STATED FOR THE EQUIPMENT IS A CONSIDERATION IN LIMITING SENTROL, INC.'S LIABILITY. NO ACTION, REGARDLESS OF FORM, ARISING UNDER THIS WARRANTY MAY BE BROUGHT BY PURCHASER MORE THAN ONE (1) YEAR AFTER THE CAUSE OF ACTION HAS ACCRUED.

This Limited Warranty gives you specific legal rights and you may also have other rights which vary from state to state. Some states do not allow limitation on how long an implied warranty will last or the limitation or exclusion of incidental or consequential damages, so the above limitations or exclusion may not apply to you, if not allowed by law.

SECTION 13: SPECIFICATIONS

INPUT POWER REQUIREMENTS:	16.5V, 20VA (TRANSFORMER SUPPLIED)
STANDBY BATTERY: RECOMMENDED TYPE:	12 VOLT RECHARGEABLE GEL-TYPE (NOT SUPPLIED) YUASA 6 OR 7AH 12 VOLT BATTERY FOR RESIDENTIAL APPLICATIONS. YUASA 12 VOLT 18AH BATTERY FOR COMMERCIAL INSTALLATIONS.
TEMPERATURE OPERATION RANGE:	32 TO 120 DEGREES FAHRENHEIT
AUXILIARY AND FIRE POWER OUTPUT:	12.5VDC REGULATED AT 600mA FOR RESIDENTIAL APPLICATIONS AND 500mA FOR COMMERCIAL INSTALLATIONS.
BELL OUTPUT:	12.5VDC TOTAL CURRENT NOT TO EXCEED 300mA FOR UL COMMERCIAL AND RESIDENTIAL APPLICATIONS.
ZONE RESPONSE TIME:	PROGRAMMABLE FROM 10mS TO .5 SECONDS.
MAXIMUM LOOP RESISTANCE:	NOT TO EXCEED 300 OHMS ON ANY LOOP. (DOES NOT INCLUDE EOL RESISTOR)
TRANSIENT AND LIGHTNING PROTECTION:	LIGHTING AND SURGE PROTECTION ON ALL INPUT, POWER, AND TELEPHONE LINES.
DIMENSIONS:	13.2"H x 13.2"W x 3.0"D RESIDENTIAL ENCLOSURE. 14.72"H x 14.72"W x 3.72"D COMMERCIAL ENCLOSURE.
FCC REGISTRATION NUMBER:	4T2USA-24862-AL-E
RINGER EQUIVALENCE:	0.2B.
LOAD NUMBER (CANADA):	LN = 2

Index

A

ABBREVIATED ARMING 32
AC 10
 REPORT DELAY 31
ANSWER CALL 13
ANSWERING MACHINE BYPASS 18
ANTI-JAM 25
ARMED OUTPUT 8. *See also* WIRING: TERMINAL
 DESCRIPTIONS: ARMED OUTPUT
ASSIGNABLE OUTPUT 29. *See also* bell; WIRING
AUDIBLE WARNING 8. *See also* WIRING: TERMINAL
 DESCRIPTIONS: AUDIBLE WARNING OUTPUT
AUTO CALL ANSWER 18
AUTO SCROLL 28
AUTO-ARM 20, 27, 31
AUXILIARY POWER. *See* WIRING: TERMINAL DE-
 SCRIPTIONS: AUXILIARY POWER

B

BATTERY 10, 26
BELL 8, 29. *See also* WIRING: TERMINAL DESCRIP-
 TIONS: ASSIGNABLE OUTPUT
 SHUT OFF 31
BELL MODULE 29
BELL SHUTOFF, ANY KEYPAD 28
BYPASS 30

C

CALL BACK SECURITY 18
CALL STATION 13
CHIME 28, 30
CLEAR LINE 15
CLOSING
 BY E/E GROUP 27
COMMON ZONING 19
COMMUNICATIONS FORMATS. *See* REPORTING
 FORMATS
CONDITIONAL OPENING 27
CONDITIONAL OPENING SIGNAL 20
CONMOD 9
COPY PROM 14
COURTESY OUTPUT 9

D

DATA OUTPUT BOARD 5, 9, 13, 29
DELETE CALL WAITING 25
DELETE CHARACTER 15
DIALING PAUSE 25
DOOR STRIKE 32
DOWNLOAD 18, 26

E

EMERGENCY KEY 28
ESCAPE KEY 15

F

FAIL TO COMMUNICATE 10, 25, 28, 29
FORCE ARM 20, 27

G

GROUND 9

H

HISTORY 13–14
 CLEAR 13
 PRINT 13
 VIEW 13–14

I

INCREMENTING ACCOUNT NUMBER 28. *See also*
 PARTITIONING: INCREMENTING OF ACCOUNT
 NUMBER
INSTALLER CODE 15
INSTALLER PRIVACY 15, 28
INTERIOR ZONES. *See* BYPASS

K

KEYPAD 9
 DESCRIPTION 12
 EKP1 5, 11
 EKP1000L 11
 KEYS 12
 SK1L 5
 WIRING 9, 11
KEYSWITCH 9

L

LATCHED FIRE BELL 28
LINE CUT 5
LOW BATTERY
 REPORT DELAY 31

M

MULTI-PREMISE 28

N

NEXT/PREVIOUS KEYS 15

O

OPENING
 BY E/E GROUP 27
OPENING/CLOSING BY EXCEPTION 31

P

PANEL PASSWORD 32
PANIC 30
PARTITIONING 18
 INCREMENTING ACCOUNT NUMBER 28
PREALARM. *See* WIRING: TERMINAL DESCRIPTIONS:
 AUDIBLE WARNING OUTPUT
PRINTER 13, 29
PROGRAMMING
 INSTRUCTIONS 16
 ITEM DESCRIPTION 25

R

READY OUTPUT 8
REPORTING FORMATS 25
RING BACK 12, 28
RING DETECT 28

S

ScanPro 20, 25
SECOND DIAL TONE 25
SMOKE RESET 28
SPECIFICATIONS 37
STATION CODE 27
STATUS CODE 27
STATUS MODULE 29
STROBE LIGHT 29

T

TELEPHONE 9, 25
TERMINAL DESCRIPTIONS. *See* WIRING
TEST CODE 26
TESTING 10
TIMER 29
 TEST 31
TONE DIAL 28
TROUBLE 26

U

UPLOAD
 SECURE UPLOAD 28
UPLOADING 18
USER ATTRIBUTES 32
USER GROUP BOUNDARY 32
USER PASS CODES 32

V

VIEW HISTORY 13

W

WIRING
 TERMINAL DESCRIPTIONS 8–9
 AC 8
 ARMED OUTPUT 8
 ASSIGNABLE OUTPUT 8
 AUDIBLE WARNING OUTPUT 8
 COURTESY OUTPUT 9
 READY OUTPUT 8
 SMOKE POWER 8
 TRANSFORMER 8

Z

ZONE
 ASSIGNED TO KEYPAD 31
 ASSIGNED TO USER 32
 BURGLARY 30
 DAY/NIGHT 30
 DELAY 30
 DESCRIPTIONS 31
 FIRE 30
 INPUTS 9
 RESPONSE TIME 30
 TROUBLE 30