

Washer-Extractor

HP Series Installation and Operation Manual

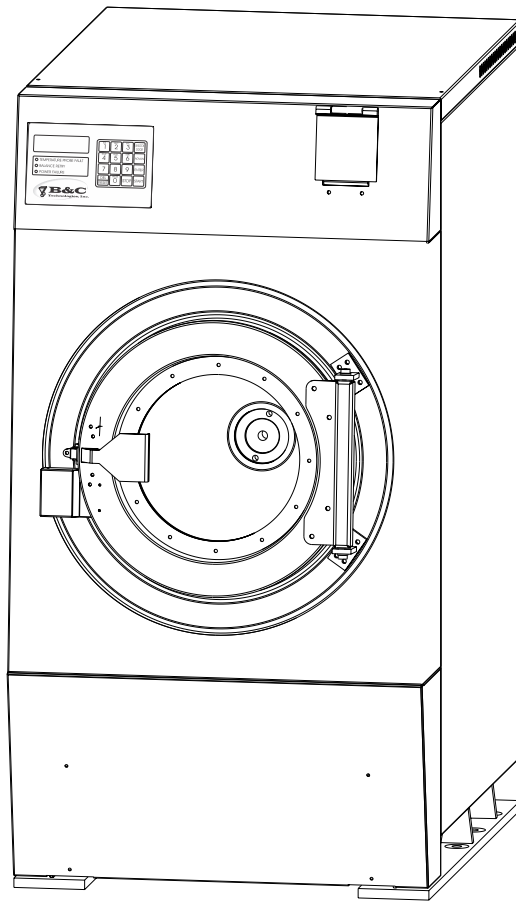

B&C Technologies

Panama City, FL
(850) 249-2222
(850) 249-2226 FAX
www.bandctech.com

Revision 2.0
22-Apr-2015

Table of Contents

Introduction	
Customer Service	3
Replacement Parts	3
General Specifications	4
Safety Information	5
Key Symbols	5
Safety Checklist	6
Installation	
Theory of Operation	11
Inspection and Uncrating	13
HP-65 Technical Specs	14
HP-125 Technical Specs	15
Dimensional Clearance	17
Foundation	18
Drain Connection	22
Electrical Installation	23
Water Connection	24
Steam Connection	25
External Chemicals	26
Function Test	29
Routine Maintenance	31
Decomissioning	36

B&C Technologies

Panama City, FL
(850) 249-2222
(850) 249-2226 FAX
www.bandctech.com

Introduction

HP Series Washer-Extractors

The B&C HP line is the professional fixed mount washer-extractor series of machines from B&C Technologies. It is an open pocket washer-extractor with a large door opening for easy and quick loading and unloading. It has been developed for the on premise market, and is suitable for commercial laundries, hotel and other places where laundry might be processed

The design allows for top performance at lowest possible operation cost and investment. The flexible electronic control center ensures that maximum productivity is obtained.

The HP series utilizes high quality material, such as 304 (18/8) stainless steel in vital parts in contact with the wash solution. It has a stainless steel cabinet for long life with easily removable panels.

The key advantages of this series are the simplicity of the microprocessor and the electronic AC drive system, which utilizes only one motor. The system allows for washing and extraction at any speed and mechanical action to suit any textile fiber used today and tomorrow. The high speed final extraction saves time and energy in the finishing operation.

A single compartment supply dispenser for powder and liquid detergents is standard (five compartment optional) and the machine is designed to accept the connection of 8 additional external chemical lines and pumps. Additional chemical connections are available as an option.

The HP series is also prepared to accept the connection of water reuse systems. These systems can be installed separate or on top of the machine. They are available in either single or dual tanks for

maximum savings of water up to 40%. The tanks can be equipped with or without steam or electrical heat depending on installation and operation. The water reuse system is programmable by the machines electronic control center.

Customer Service

For technical assistance, call the following number:

Phone: (850)-249-2222

FAX: (850) 249-2226

e-mail: service@bandctech.com

Web: www.bandctech.com

Replacement Parts

In the event that literature or replacement parts are required, contact the local distributor of the equipment, or contact B&C Technologies at the above phone numbers/internet addresses.

Introduction

General Specifications

MODEL	Units		HP-65		HP-125	
	Metric	US				
CAPACITY:	kg	lbs	29.5	65	56.8	125
OVERALL DIMENSIONS:						
A - Width	mm	in	879	34.6	1295	51.0
B - Depth	mm	in	1194	47.0	1554	61.2
C - Height	mm	in	1651	65.0	1669	65.7
WEIGHT AND SHIPPING INFORMATION:						
Net weight	kg	lbs	660	1450	1489	3275
Domestic shipping weight	kg	lbs	720	1584	1505	3310
CYLINDER INFORMATION:						
Diameter	mm	in	790	31.1	1067	42
Depth	mm	in	560	22	610	24
Volume	liters	cu ft	274	9.7	540	19
CYLINDER SPEEDS:						
Wash	G	rpm	0.8	42	0.8	37
Distribution	G	rpm	2	67	3	71
Intermediate extract	G	rpm	150	583	50	290
High extract 1	G	rpm	200	673	100	410
High extract 2	G	rpm	250	753	150	502
High extract 3	G	rpm	300	825	200	579
DOOR OPENING AND HEIGHT:						
Diameter	mm	in	450	17.7	508	20
Height of door bottom above floor	mm	in	635	25	400	28
DRIVE INFORMATION:						
Number of motors	Number		1		1	
Size of motor	kW	Hp	3.7	5	7.5	10
WATER INLETS						
Hot water size	NPT		3/4		1	
Cold water size	NPT		3/4		1	
Additional water inlet	NPT		3/4		1	
DRAIN OUTLETS AND CAPACITY:						
Number of drains	Number		1		1	
Drain size	mm	in	76.2	3	76.2	3
STEAM INLET and CONSUMPTION:						
Steam inlet size	NPT		1/2		1	
ELECTRICAL SERVICE:						
208-240VAC, 50/60Hz, 1PH	Amps	Breaker	14	15	n/a	n/a
208-240VAC, 50/60Hz, 3PH	Amps	Breaker	8	15	32	40
380-480VAC, 50/60Hz, 3PH	Amps	Breaker	4	15	16	20

Due to our policy of ongoing improvements, all specifications are subject to change without notice.

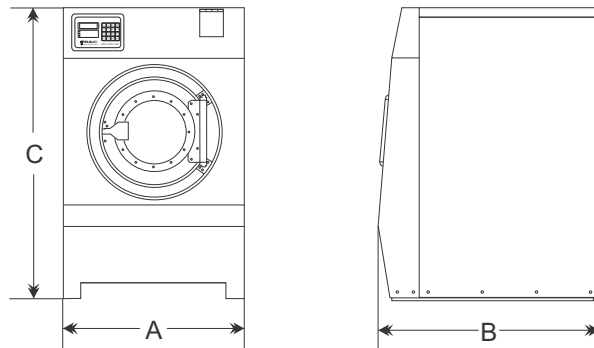

Key Symbols

Anyone operating or servicing this machine must follow the safety rules in this manual. Particular attention must be paid to the DANGER, WARNING, and CAUTION blocks which appear throughout the manual



The lightning flash and arrowhead within the triangle is a warning sign alerting you of the presence of dangerous voltage.



This warning symbol indicates the presence of hot surfaces that could cause serious burns. Stainless steel and steam lines can become extremely hot and should not be touched.



The exclamation point within the triangle is a warning sign alerting you of important instructions concerning the machine and possible dangerous conditions.



This warning symbol indicates the presence of possible dangerous pinch-points. Moving mechanical parts can crush an/or sever body parts.



This warning symbol alerts you to the presence of possible dangerous drive mechanisms within the machine. Guards should always be in place when the machine is in operation. Be careful when servicing any drive mechanism.



Before servicing any equipment, make certain it is disconnected from the electrical power source. Never allow operation of the machine when any safety device is malfunctioning. Never bypass safety devices.



This warning symbol indicates the presence of possibly dangerous chemicals. Proper precautions should be taken when handling corrosive or caustic material.

Introduction

Safety Checklist

Before Initial start up of a B&C washer extractor perform the following safety check:

- A. Make sure all electrical and plumbing connections have been made in accordance with applicable codes and regulations.
- B. Make sure the machine is grounded electrically.
- C. Make sure the machine has flexible water fill and drain connections of the correct size, length and type, with no kinks, and that they are securely attached and/or clamped.

Before machine is placed in operation, the door safety interlock must be checked for proper operation as follows:

- A. When the washer is energized electrically and in operation, the loading door must be locked in the closed position. Verify this by attempting to open the loading door when the machine is operating. If necessary, check the door safety interlock and sensors for proper operation. Consult the service manual, or call a qualified service technician if necessary.
- B. When the washers loading door is open, it should not be possible to start the machine. Verify this by attempting to start the washer with the door open. Also, close the door without locking it and verify that it is not possible to start the machine with the door not locked. If necessary, check the door lock sensors for proper operation,. Consult the service manual, or

call a qualified service technician. If additional information is required, contact your local distributor or call the manufacturer of the machine.

Before servicing any equipment, make certain it is disconnected from the electrical power source. Never allow operation of the machine when any safety device is malfunctioning. Never bypass safety devices.



Introduction

Safety Checklist

To provide personal safety and keep the machine in proper working order, follow all maintenance and safety procedures presented in this manual. If questions regarding safety arise. Contact the factory immediately.

Use factory authorized spare parts to avoid safety hazards.

Operator safety



Never insert hands or objects into basket until it has completely stopped. Doing so could result in serious injury

3.2 Excessively high water level is evident.

3.3 Machine is not connected to a properly grounded circuit.

Do not bypass any safety devices in the machine.



damage.

Never operate the machine with a bypassed or disconnected out-of-balance switch. Operating the machine with severe out-of-balance loads could result in personal injury and serious equipment

To ensure the safety of machine operators the following maintenance checks must be performed daily.

1. Prior to operating the machine, verify that all warning signs are present and legible. Missing or illegible signs must be replaced immediately. Make certain that spares are available.
2. Check door interlock before starting operation of the machine, see safety check list.
3. Do not attempt to operate the machine if any of the following conditions are present:

3.1 The door does not remain securely locked during the entire cycle.

Introduction

Safety Checklist

Safe Operation Environment

Safe operation requires an appropriate operating environment for both the operator and the machine. If questions regarding safety arise, contact the factory.

Environmental Conditions

1. Ambient temperature. Water in the machine will freeze at temperatures of 32F (0C) or below. Temperatures above 120 F (50C) will result in more frequent motor overheating and, in some cases, malfunction or premature damage to solid state devices that are used in the machines. Special cooling devices may be necessary.

2. Humidity. Relative humidity above 90% may cause the machine's electronics or motors to malfunction or may trip the ground fault interrupter. Corrosion problems may occur on some metal components. If the relative humidity is below 30% belts and rubber hoses may eventually develop dry rot. This condition can result in hose leaks, which may cause hazards external to the machine in conjunction with adjacent electrical equipment.

3. Ventilation. The need for make-up air openings for such laundry room accessories as dryers, ironers, water heaters, etc. must be evaluated periodically. Louvers, screens, or other separating devices may reduce the available air opening significantly..

4. Radio Frequency Emissions. A filter is available for machines in installations

where floor space is shared with equipment sensitive to radio frequency emissions. All machines that are shipped to CE countries are equipped with this filter and comply with the EMI regulations.

5. Elevation. If the machine is to be operated at elevations over 3280 feet (1000 meter) above sea level, pay special attention to water levels and electronic settings (particularly temperature) or desired result may not be achieved.

6. Chemicals. Keep stainless steel surfaces free of chemical residues to avoid corrosion.

7. Water damage. Do not spray the machine with water. Short circuiting and serious damage may result. Repair immediately all seepage due to faulty gaskets, etc.



Do not place volatile or flammable fluids in any machine. Do not clean the machine with volatile or flammable fluids such as acetone, lacquer thinners, enamel reducers, carbon

tetrachloride, gasoline, benzene, naphtha, etc. Doing so could result in serious personal injury and/or damage to the machine.

Machine Location

1. Foundation. The concrete floor must be of sufficient strength and thickness to handle the floor loads generated by the machine at high extract speeds.

Introduction

Safety Checklist

2. Service/ Maintenance Space. Provide sufficient space to allow comfortable performance of service procedures and routine maintenance. This is especially important in connection with machines equipped with AC inverter drives. Consult installation instructions for specific details.

Replace all panels that are removed to perform service and maintenance



procedures. Do not operate the machine with missing guards or with broken or missing parts. Do not bypass any safety devices

Input and output

services

1. Water pressure. Best performance will be realized if water is provided at a pressure of 30-85 psi (2.0-5.7 bar). Although the machine will function properly at lower pressure, increased fill time will occur. Water pressure higher than 120 psi (8.0 bar) may result in damage to machine plumbing, component failure (s) and personal injuries.

2. Optional Steam heating pressure. Best performance will be realized if steam pressure is provided at a pressure of 30-80 psi (2.0-5.4 bar). Steam pressure higher than 125 psi (8.5 bar) may result in damage to steam components and may cause personal injuries. For machines equipped with optional steam heat, install piping in accordance with approved commercial steam practices. Failure to

install the supplied steam filter may void the warranty.

3. Drainage System. Provide drain lines or troughs large enough to accommodate the total quantity of water that could be dumped if all machines on the site drained at the same time from the highest attainable level. If drain troughs are used, they should be covered to support light foot traffic

4. Power. For personal safety and for proper operation, the machine must be grounded in accordance with state and local codes. The ground connection must be to a proven earth ground, not to conduits or water pipes. An easy-access disconnect switch should be provided.

Ensure that a ground wire from a proven earth ground is connected to the ground lug in the electrical junction box on this machine. Without proper grounding personal injury from electrical shock could occur and machine malfunctions may be evident. Computer-controlled machines must have a proper ground to prevent computer malfunctions.

Always disconnect power and water supplies before a service technician



performs any service procedure. Where applicable, steam and/or compressed air supplies should also be disconnected before service is performed

Introduction

Safety Checklist

AC Inverter Drive

Machines equipped with AC drives require special attention with regard to the operating environment.

1. An especially dusty or linty environment will require more frequent cleaning of the AC drive cooling fan filter and of the AC drive itself.
2. Power line fluctuations from sources such as an interruptible power supplies (UPS) can adversely affect machines equipped with the AC drive. Proper suppression devices should be utilized on the incoming power to the machine to avoid problems.
3. A clean power supply free from voltage spikes and surges is absolutely essential for machines equipped with the AC drive. Nonlinear inconsistencies (peaks and valleys) in the power can cause the AC drive to generate nuisance errors. If voltage is above 230V for 200 V installations or above 440V for 400V installations, a buck/boost transformer is recommended. If voltage is above 240V or 480V, a buck/boost transformer is required unless the factory advises differently.
4. Sufficient space to perform service procedures and routine preventive maintenance is especially important for machines equipped with AC drives.

Misuse

Even though this machine is an atmospheric vessel, never use it for any purpose other than washing fabrics.

1. Never wash petroleum-soaked rags in the machine. This could result in an explosion
2. Never wash machine parts or automotive parts in the machine. This could result in serious damage to the basket.
3. Never stone wash in the machine. It could wear the basket and serious damage might occur to the machine.
4. Never use the machine for dyeing and with harsh chemicals that can cause corrosion and other health hazards.
5. Never allow children to play on or around this machine. Death or serious injury can result if children become trapped in the machine. Do not leave children unattended while the machine door is open. these cautions apply to animals as well.

Installation

Theory of Operation

The B&C HP models use a single-speed motor to drive the cylinder via V-belts in all speeds. The cylinder is supported by two spherical roller bearings located in a bearing housing made of cast iron.

The motor is controlled by the computer control located in the front and the AC inverter drive located in the rear panel. Any speed can be programmed for any wash cycle. Some speed ranges are blocked out for programming due to safety reasons. This speed range is not important and normally speeds for wash or extraction are not selected within this range. Any wash speed in the range of 10-50 RPM and extraction speeds 150-Maximum RPM can be programmed. Further any reversing action can be programmed. Normal reversing action is 18 seconds forward, pause for 3 seconds, and 18 seconds reverse. Any temperature between 70F to 200F (20-95C) can be programmed. Any water level in the range of the machine parameters can be programmed in centimeters. The computers will automatically provide safety levels for steam injections and door operations.

Water entry into the machine is through an air gap vacuum breaker utilizing electro-magnetic water valves controlled by the computer. By utilizing the air gap vacuum breaker, backflow into the water supply is impossible. The computer also controls the drain, supply dispenser, any external liquid supplies, steam injection and any other vital functions of the wash program. The computer can even record cycles and data of importance that could be used for maintenance purpose.

The steam, if installed is injected in the bottom of the shell via a steam injector. The steam is controlled by a steam valve that is programmed by the micro computer.

The cylinder is perforated, allowing water to pass through and drain from within during drain and extract steps. Lifting ribs inside the cylinder lift the load from the wash solution and allow the load to tumble and falling back into the solution when the load reaches the approximate 10-11 o'clock or 1-2 o'clock positions. This mechanical action removes soil from the fabric. Furthermore, the lifters are perforated on the top so that water can cascade over the goods and wet them quickly. This reduces water consumption as water is picked up at the cylinder's lowest point and lifted and splashed over the goods at the highest point as the cylinder rotates.

A stainless steel door is provided for loading and unloading. A door lock system prevents operation of the machine when the door is open. The door is locked during operation utilizing an air cylinder and a manual latch for safety reasons. The door lock is provided with magnetic sensor to indicate that the machine is locked and provide for start of the machine when the door is closed and locked.

The AC drive, contactor, circuit overload protectors, input power supply connections, external supply connections, and control transformer are behind a cover of the rear of the machine.

The supply dispenser is mounted on the

Installation

Theory of Operation

front of the machine and is accessed by opening the cover door. Supplies, both liquid and powder; may be added by pulling the dispenser cups out and placing the appropriate supply in each. Supplies are flushed into the machine at the proper time in the cycle, controlled by the micro computer.

Holes are provided at the rear of the machine for connection to an external, central liquid supply unit. Electrical connections are provided for the liquid supply unit on a terminal strip inside the rear control module. Refer to page for connection details.

Installation

Inspection and Uncrating

Delivery inspection

Upon delivery, visually inspect crate, protective cover, and unit for any visible shipping damage. If the crate, protective cover, or unit are damaged or signs of possible damage are evident, have the carrier note the condition on the shipping document before the shipping receipt is signed, or advise the carrier of the conditions as soon as it is discovered.

Remove the crate and protective cover as soon after delivery as possible. If any damage is discovered upon removal of the crate and/or protective cover, advise the carrier and file a written claim immediately.

Customer Service

If literature or replacement parts are required contact the source from whom the machine was purchased or contact :

B&C Technologies
(850) 249-2222
(850) 249-2226 FAX
info@bandctech.com
www.bandctech.com

for the name of the nearest authorized parts distributor.

A record of each machine is on file with the manufacturer. The serial number decal is located at the rear of the machine. Always provide the machine's serial number and model number when ordering parts or when seeking technical assistance.

NOTE!

Keep the manuals, installation instructions and the wiring diagrams which accompany the machine in a safe place for ready reference. They have been included with the machine at no charge. Additional copies are available at a nominal charge.

Installation

HP-65 Technical Specifications

MOUNTING BOLT DETAIL

Foundation details are in the HP Series Installation & Operation Manual

REV	BY	DATE	REV DESCRIPTION
A1	AFA	9-30-2013	Created

DRAWN BY: A. Adcock 9-30-2013
 CHECKED BY: S. Brown 9-30-2013
 DESCRIPTION: General Technical Specifications

Penaras City, FL
 Phone: 850-246-2222
 Fax: 850-249-2226
 www.bandtech.com

B&C
 Band Tech Corporation

HP-65
 General Technical Specifications

DATE: 9-30-2013 FILE NAME: HP-65GenSpec.cdr SHEET: 1 OF 1

Electrical Requirements

Voltage	Phase	System Wire	Wire Size	Amps	Breaker
208-240VAC, 50/60Hz, 1PH	1	2 + GND	14	14	15
208-240VAC, 50/60Hz, 3PH	3	3 + GND	14	8	15
380-460VAC, 50/60Hz, 3PH	3	3 + GND	14	4	15
208-240VAC, 50/60Hz, 3PH Elec. Heat	3	3 + GND	4	52	60
380-460VAC, 50/60Hz, 3PH Elec. Heat	3	3 + GND	10	26	30

Drain Requirements

Connection	Discharge Rate	Min Sewer Line
inches	mm	inches
3	76	4
	62	235
		102

Water Requirements

Connection Size	Water		Flow Rate @45PSI(3Bar)	Minimum Supply		Max Operating Pressure	
	Line Pressure	Max Temp		Line Size	Line Size	US	Metric
US: 1/2	PSI: 30-75	Bar: 2-5	F: 200	C: 93	US: 1	Metric: DN 25	US: 125 PSI
Metric: 3/4"	30-75	2-5	200	93	1	DN 25	8 Bar

Steam Requirements

Steam		Minimum Supply		Max Operating Pressure	
Connection Size	Line Pressure	Line Size	Line Size	US	Metric
US: 1/2	PSI: 30-75	Bar: 2-5	DN 12	100 PSI	8 Bar
Metric: 1/2	30-75	2-5	DN 12	100 PSI	8 Bar

Dynamic Load Specifications

Static Load		Dynamic Load	
lbs	kg	lbs	kg
1450	6.5	4205	18.7
			14.33

Shipping Data

Type	lbs	kg	cu ft	cu m
Domestic	1450	660	68	2
Export	1584	720	68	2

Installation

Dimensional Clearances

When installing the washer-extractor, it is important to allow adequate clearance on all sides of the machine. When multiple machines are installed, it is important to allow for the specified minimum clearances between machines. The following table shows recommended minimum clearances for the various freestanding models.

Note

The dimensions are approximate and subject to normal manufacturing tolerances. If exact dimensions are required for construction purposes, request certified drawings from the factory. We reserve the right to make changes at any time without notice.

	UNITS Metric	UNITS US	HP Series			
			Recommended		Minimum	
(A) Minimum rear clearance	mm	in	760	30	305	12
(B) Minimum clearance between machine and wall	mm	in	455	18	25	1
(C) Minimum clearance between machines	mm	in	455	18	25	1
(D) Minimum front clearance	mm	in	838	33	838	33

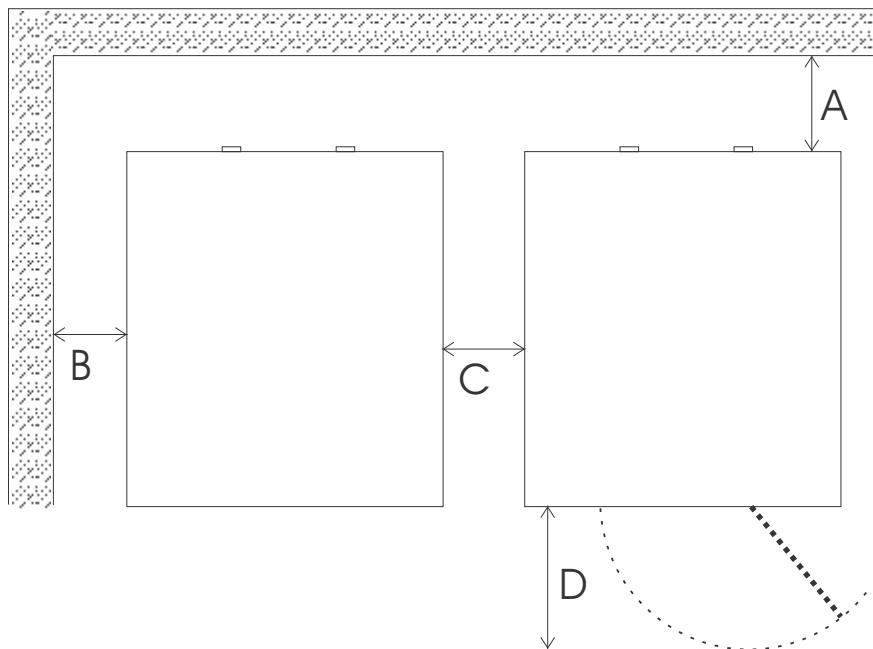

Installation

Machine Foundation

A proper foundation is an absolute necessity when installing a fixed mount washer extractor. Do not neglect details when doing foundation work. These details will ensure a stable installation, reducing the possibility of excess vibration at high speeds.

The machine must be anchored to a smooth level surface so that the entire base of the machine is supported and rests on the mounting surface. Note! Do not support the machine at only four points.

A concrete base designed to elevate the washer-extractor to a more comfortable working height may be used. Use care when designing a base, as the forces generated during extract are extreme. The base must be adequately tied into existing floor.

Do not attempt to install this machine on wooden flooring of any kind, above ground level, or over basements. Installation must be slab on grade or equal.

Ensure that the machine is installed on a

level floor of sufficient strength and that the recommended clearances for inspection and maintenance are provided. Never allow the inspection and maintenance space to be blocked



Floor Load Data

Model	Static Load		Dynamic Load		Dynamic Frequency
	lbs	kN	lbs	kN	Hz
HP-65	1764	7.85	3906	17.4	13.8
HP-125	3898	17.34	5003	22.3	9.7

Installation

Foundation Bolt Location

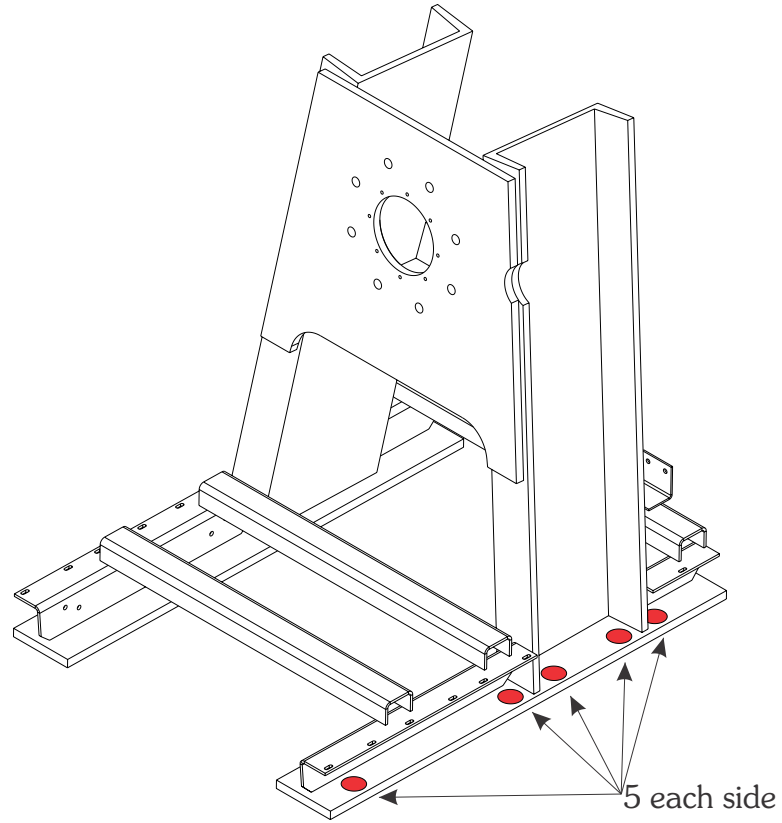

Typical Grouting Pattern

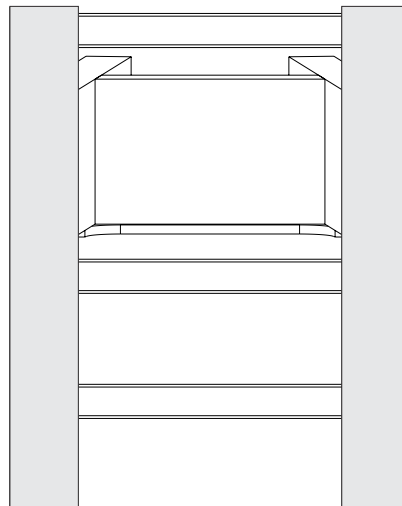

Front of Machine

Installation

Mounting Bolt Installation

All B&C washer-extractors must be secured by the use of machinery anchor bolts. High strength machinery anchors should be embedded in 3500 psi (24000 N/m²) reinforced concrete. See Figure. For detailed information regarding the machine anchor bolt, see the instructions included with the anchor bolts themselves. The following information is just an example.

After the concrete has cured, proceed as follows:

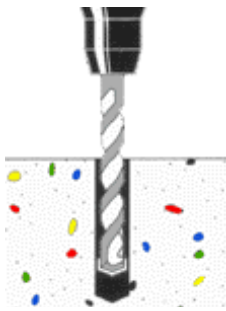

Select a carbide drill bit with a diameter equal to the anchor diameter. Drill hole to any depth exceeding the desired embedment.

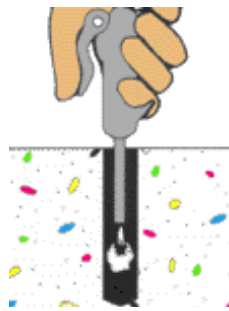

Clean hole or continue drilling to accommodate drill fines (concrete dust). Please wear eye protection.

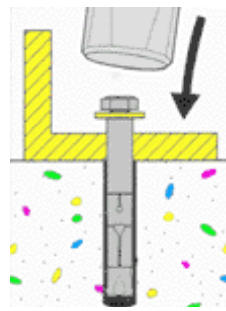

Drive the anchor into the hole through material being fastened until washer is flush with material.



Expand bolt by tightening the anchor 3 to 5 turns, or to the specified torque requirements.

Place the machine adjacent to the foundation. Do not attempt to move it by pushing on the sides.

1. Remove the wood skid by unscrewing the carriage bolts holding it to the bottom frame of the machine.
2. Carefully place the machine over the anchor bolts. Raise and level it 1/2 inch above the floor on four points, using spacers that can be removed.
3. Fill the spaces between the machine base and floor with machinery grout. Grout completely under the frame members. Remove front panel and rear panel to gain access to all frame members. Force grout under the machine base until all voids are filled.
4. Remove the spacers carefully, allowing the machine to settle into the wet grout.
5. Attached the mounting bolt washers and lock nuts to the anchor bolts after the grout has hardened. Tighten the lock nuts by even increments-one after the other-until all are tightened evenly and the machine is fastened securely to the floor. The nuts should be tightened in a diagonal fashion, which will help ensure equal tension at all anchor points.

Installation

Machine Foundation

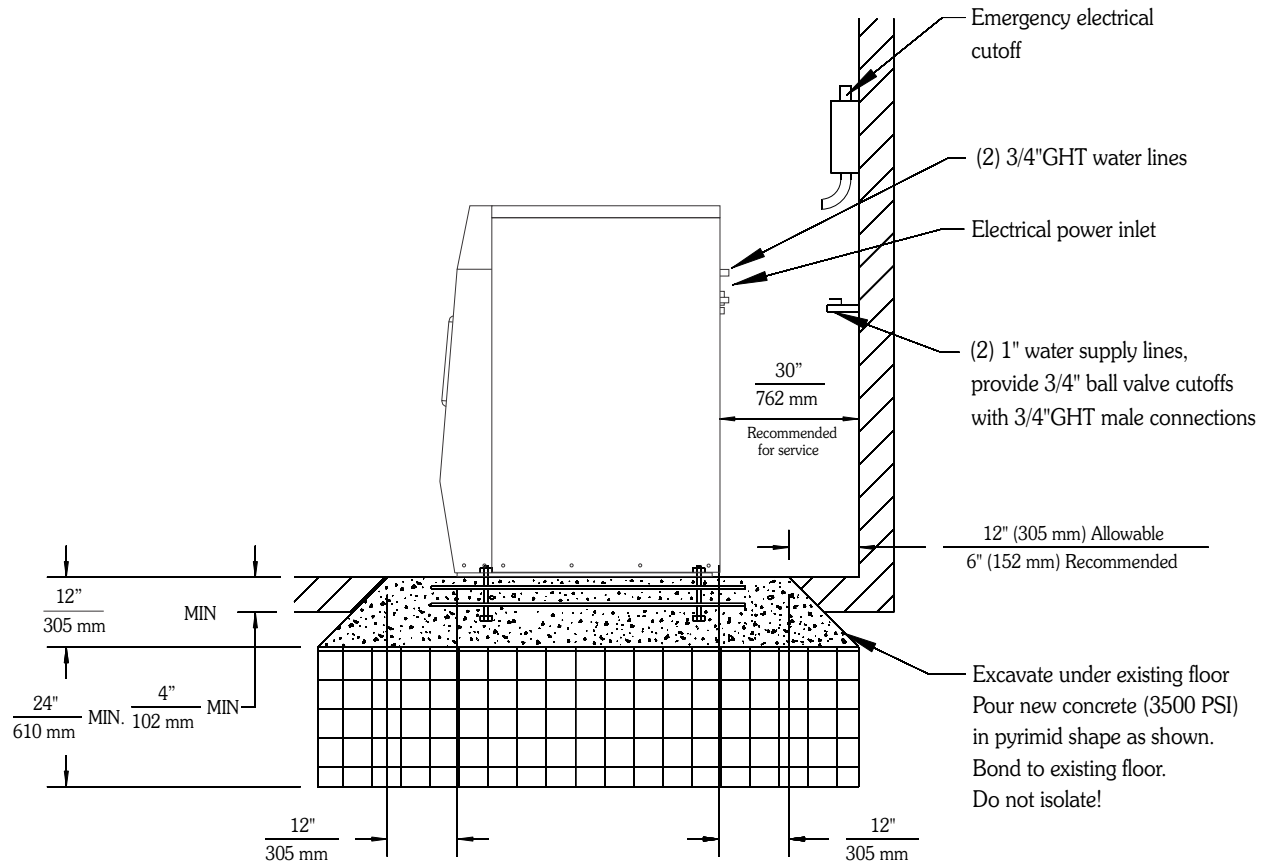

Place the machine adjacent to the foundation. Do not attempt to move it by pushing on the sides.

1. Remove the wood skid by unscrewing the carriage bolts holding it to the bottom frame of the machine.
2. Carefully place the machine over the anchor bolts. Raise and level it 1/2 inch above the floor on four points, using spacers that can be removed.
3. Fill the spaces between the machine base and floor with machinery grout. Grout completely under the frame members. Remove front panel and rear panel to gain access to all frame members. Force grout under the machine base until all voids are filled.
4. Remove the spacers carefully, allowing the machine to settle into the wet grout.
5. Attached the mounting bolt washers and lock nuts to the anchor bolts after the grout has hardened. Tighten the lock nuts by even increments-one after the other-until all are tightened evenly and the machine is fastened securely to the floor. The nuts should be tightened in a diagonal fashion, which will help ensure equal tension at all anchor points. Retighten after one week of operation.

Installation

Mounting Bolt Installation

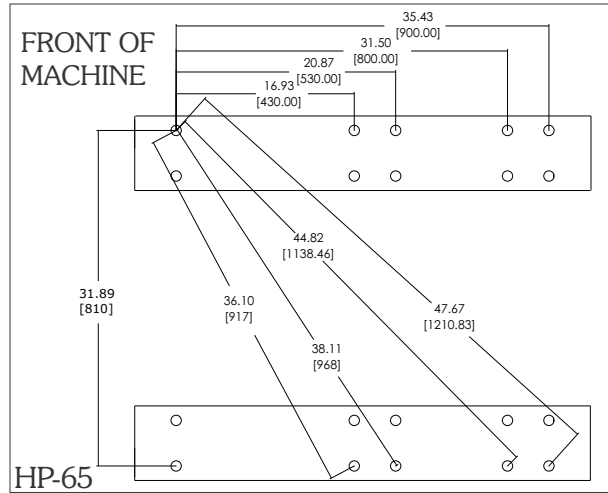
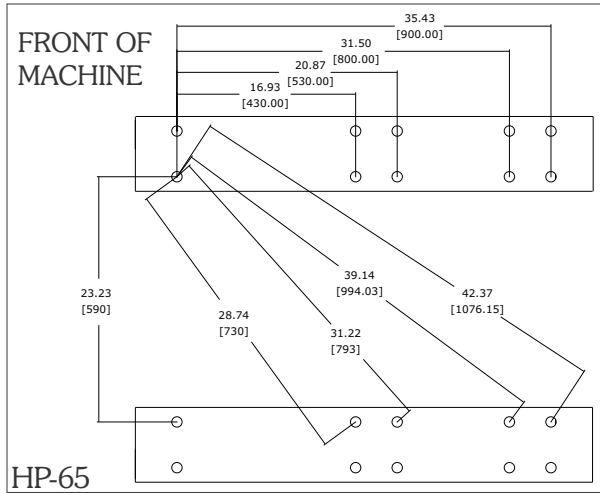

Mounting Bolt Installation

The HP-65 requires the use of 3/4-10 x 8" bolts. Embed the bolts in 3500 psi reinforced concrete with a minimum of 12" thickness. The threaded end of the bolt should extend 2 inches from the surface of the floor.

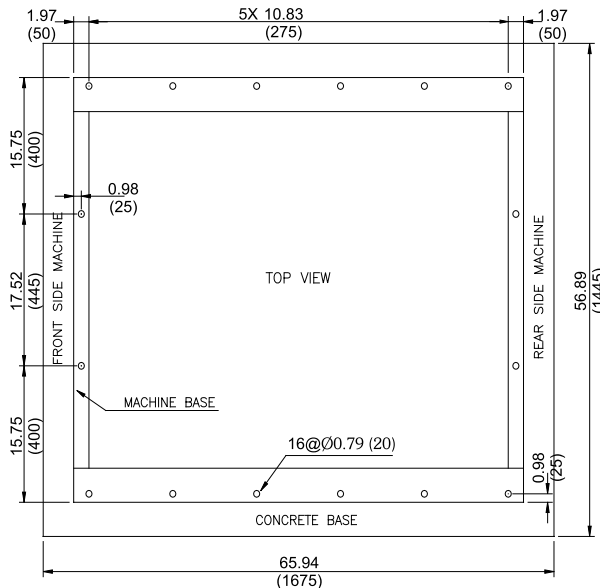

Mounting Bolt Installation

The HP-125 uses 5/8-11 x 8" bolts. Embed the bolts in 3500 psi reinforced concrete with a minimum of 12" thickness. The threaded end of the bolt should extend 2 inches from the surface of the floor.

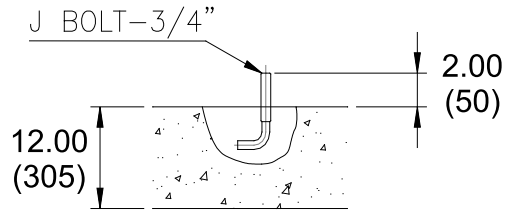

Floor Detail

Installation

Drain Connection

A drain system of adequate capacity is essential to the machine performance. Ideally the water should empty through a 4 inch vented pipe directly into a sump or floor drain. See figure.

A flexible connection must be made to a vented drain system to prevent an airlock or siphon effect. If proper drain size is not available or practical, a surge tank is required. A surge tank in conjunction with a sump pump should be used when gravity drainage is not possible, such as in below-ground-level installations.

installation procedures is attempted, the customer or installer should contact the manufacturer. Increasing the drain hose length, installing elbows, or causing bends will decrease drain flow rate and increase drain time, impairing machine performance. If the drain arrangement is inadequate, the machine will not extract and will not discharge water properly.

See table below for specific drain information.

Before any deviation from specified

Drain Sizing

	Units		Machine			
	Metric	US	HP-65		HP-125	
Drain connection Size	mm	in	76	3	76.2	3
Drain flow capacity	liters/min	gpm	581	150	560	150
Minimum drain pit size	liters	gal	388	100	850	212.5

Drain Construction

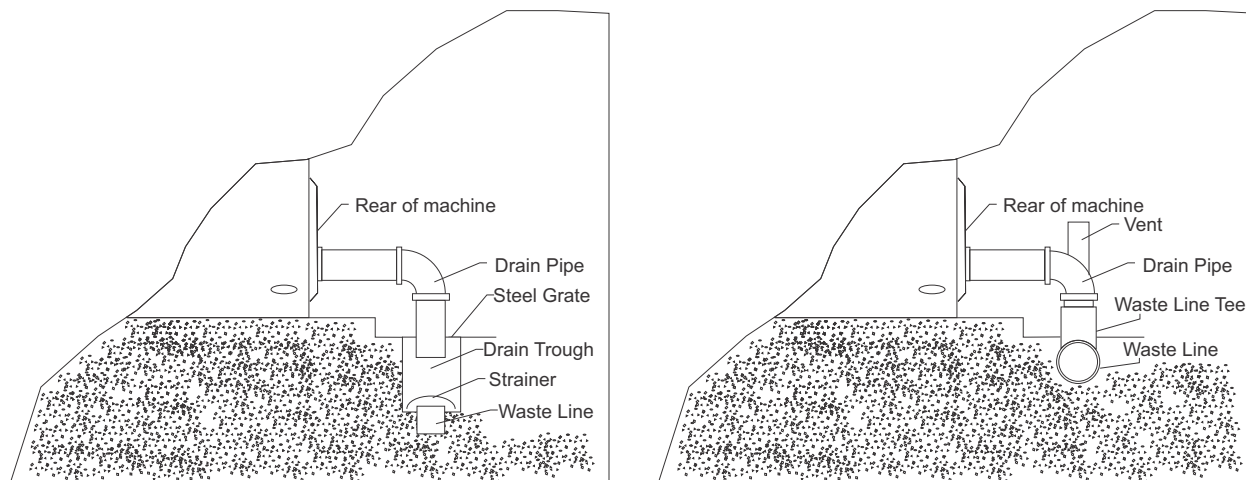

Installation

Electrical Installation

The AC drive requires a clean power supply free from voltage spikes and surges. A voltage monitor should be used to check incoming power. The customer's local power company may provide such a monitor.

The AC drive provides for an internal circuit breaker. A separate circuit breaker governs the control circuit.

If input voltage measures above 230V for a 200 V drive or above 440V for a 400V drive, either ask the power company if their representative can lower the voltage or install a step-down transformer kit available from the manufacturer. Voltages above 250V and 490V require additional measures. Contact the distributor or the manufacturer for assistance.



This machine must be installed, adjusted, and serviced by a qualified electrical maintenance personnel familiar with the construction and operation of this type of machinery. They must also be familiar with the potential hazards involved. If this warning is not observed, personal injury or equipment damage resulting in voiding the warranty may result.



When controlling the AC drive with a parameter unit, the machine's computer and its safety features are bypassed. This would allow the basket to rotate at high speeds with the door open. When using a parameter unit to control the AC drive, a large sign should be placed on the front of the machine warning people of the imminent danger.



Never touch terminals or components of the AC drive unless power is disconnected and the "CHARGE" indicator LED is off. The AC drive retains potential deadly voltage for some time after the power is disconnected. There are no user-serviceable parts inside the AC drive. Tampering with the drive will void the warranty.



Dangerous voltage are present in the electrical control boxes and at the motor terminals. Only qualified personnel familiar with electrical test procedures, test equipment, and safety precautions should attempt adjustments and troubleshooting. Disconnect power from the machine before removing the control box cover, and before attempting any service procedures.

Installation

Electrical Installation

	208-230V			380-460V		
Machine	Max Amps	Breaker	Wire Size	Max Amps	Breaker	Wire Size
HP-65, 3ph	8	15	14ga / 2.5mm	4	15	14ga / 2.5mm
HP-65, 1ph	13.6	15	14ga / 2.5mm			
HP-125, 3ph	32	40	8ga / 10mm	16	20	10ga / 4mm

Note: For single phase operation (SP-40, 60 and 100 only), connect input power to R and S, leaving the T terminal open.

Note: Do not use phase adders (roto-phase) on inverter driven equipment!

Note: Wire sizes shown are for copper, THHN, 90 conductor per NEC article 310 (USA).

The machine should be connected to an individual branch circuit not shared with lighting or other equipment.

Because this is a vibrating machine, the use of SO cable or similar, with a twist-lock plug, to connect the machine to main power is recommended. A shielded liquid tight or approved flexible conduit with proper conductor of correct size installed in accordance with National Electric Code (USA) or other applicable codes is also acceptable. The connection must be made by a qualified electrician using the wiring diagram provided with the machine. See the Electrical Connection data Chart for correct wire sizes.

For personal safety and for proper operation, the machine must be grounded in accordance with state and local codes and in the USA in accordance with the National Electric Code, article 250-96.

The ground connection must be to a proven earth ground, not to conduit or water pipes. Do not connect the ground to the neutral (N) leg at the terminal strip (if so equipped).

If a DELTA supply system is used, the high leg should be connected to T, since control voltage is derived from R and S.

Insure that the control transformer taps are connected in accordance with the incoming line voltage. Verify connections as shown on the schematic with each machine.

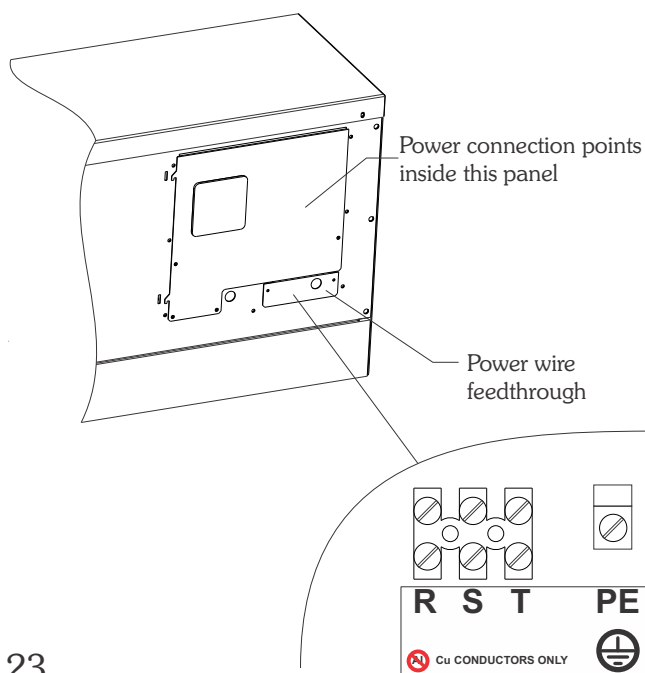

Installation

Water Connection

Individual hot and cold plumbing lines with individual shut-off valves must be available to the machine. Hot water should be minimum of 160F (70C). If lower temperature water is used the machine should be equipped for steam heating to heat the wash solution to desired temperature. Best performance will be realized if water is provided at a pressure of 30-85 psi (2-7 Bar). Although the machine will function properly at lower pressures, increased fill times will occur.

Flush the water system for at least two minutes prior to initial use..

Use flexible hoses and install separate screen filters in the lines to keep rust and other foreign particles out of the solenoid valves. Hang the hoses in a large loop. Do not allow the hoses to kink. The water connections to the machine should be supplied by a hot and cold water line of least the sizes shown in the table below. Installation of additional machines will require proportional larger water lines, see table.

To avoid eventual water hammer in the water line, suitable devices to reduce the water hammer should be installed.

NUMBER OF MACHINES	SUPPLY LINE PIPE SIZES			
	HP-65		HP-125	
	DN	Inch	DN	Inch
1	25	1	32	1-1/4
2	25	1	32	1-1/4
3	40	1-1/2	50	2
4	40	1-1/2	50	2
5	50	2	63	2-1/2
6	50	2	63	2-1/2

Installation

Steam Connection

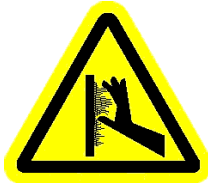

Never touch internal or external steam pipes, connections, or components. These surfaces can be extremely hot and will cause severe burns. The steam must be turned off and the pipe, connections, and components allowed to cool before the pipe can be touched

For machines equipped with optional steam heat, install piping in accordance with approved commercial steam practices. Steam requirements are shown

in the table below. Failure to install a steam filter may void the warranty.

STEAM INLET and CONSUMPTION:	UNITS		HP-65		HP-125	
Steam inlet size	DN	in	13	1/2	20	3/4
Required steam to heat bath 10F (5.55C)LOW	kg	lbs	1.5	3.2	3.8	8.4
Required steam to heat bath 10F (5.55C)HIGH	kg	lbs	1.8	4	5.8	12.76
Average Steam consumption per cycle	kg	lbs	31	66	88	194

Installation

External Chemical Supplies



Wear Eye and hand protection when handling chemicals. Always avoid direct contact with raw chemicals. Read the manufacturer's directions for accidental contact before handling chemicals. Ensure that an eye-rinse facility and an emergency shower are within easy reach. Check at regular intervals for chemical leaks.

The following procedures must be observed when connecting any chemical injector to the washer-extractor. See the figure for a typical supply injection system setup. Undiluted chemicals dripping can damage the machine. Therefore, all chemicals supply dispenser pumps must be mounted

below the washer's injection point. All dispenser tubing should also run below the injection point. Loops do not prevent drips if these instructions are not followed. Failure to follow these instructions could damage the machine and void the warranty.

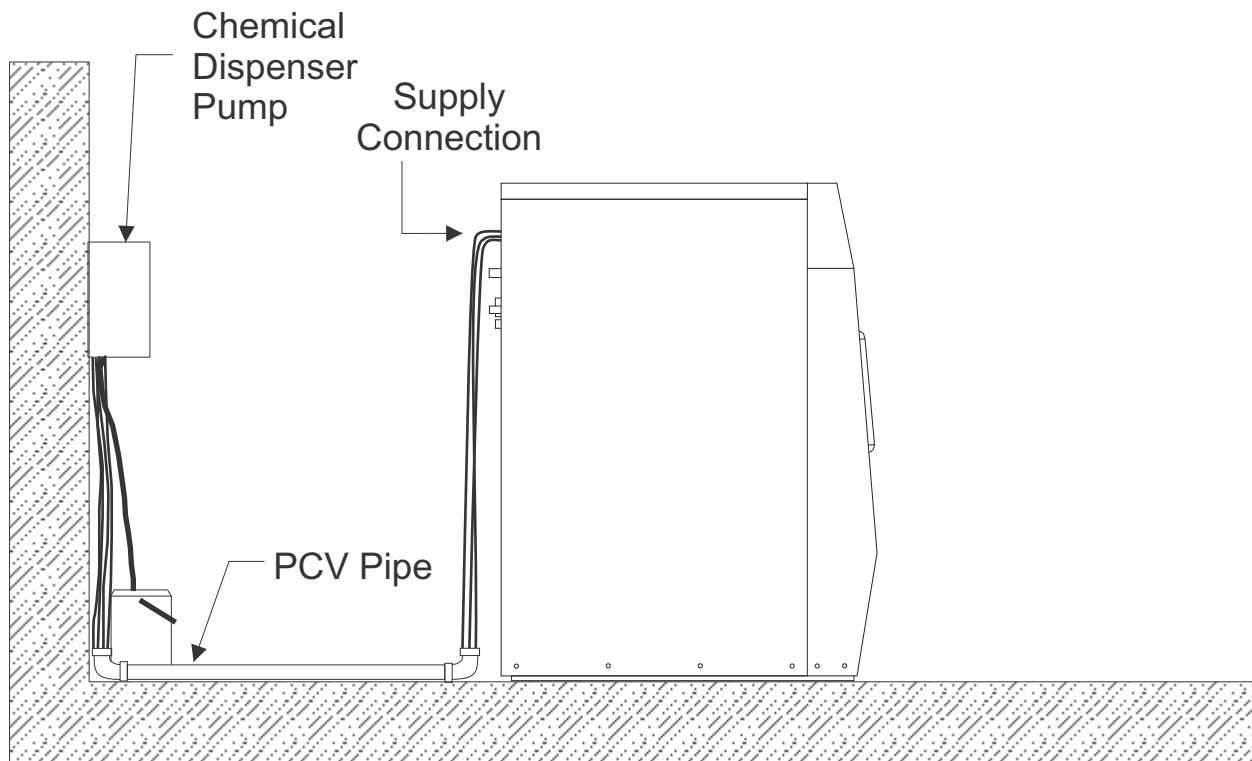

Installation

External Chemical Supplies

The supply compartment on the HP-65 is located on the front of the machine. Supply cups can be accessed by opening the dispenser lid. The supply cups can be removed and filled as desired. Supply compartments are numbered 1,2,3,4 and 5 from the left of the machine to the right for the optional 5 cup system..

External supply connections for HP-65 washer-extractors are located on rear of the machine at the vacuum breaker. Hose connections should be made via the supplied nipples or the flushing connection. You must drill the nipples prior to use (max 1/4" bit). A 1/2 NPT connection is also provided for flushing systems.

The supply compartment on the HP-125 is located on the left side of the machine. Supply cups can be accessed by opening the dispenser lid. The supply cups can be removed and filled as desired. Supply compartments are numbered 1,2,3,4 and 5 from the rear of the machine to the front.

External supply connections for the HP-125 are located on top of the supply dispenser. Hose connections should be made via the strain relief. See figure.

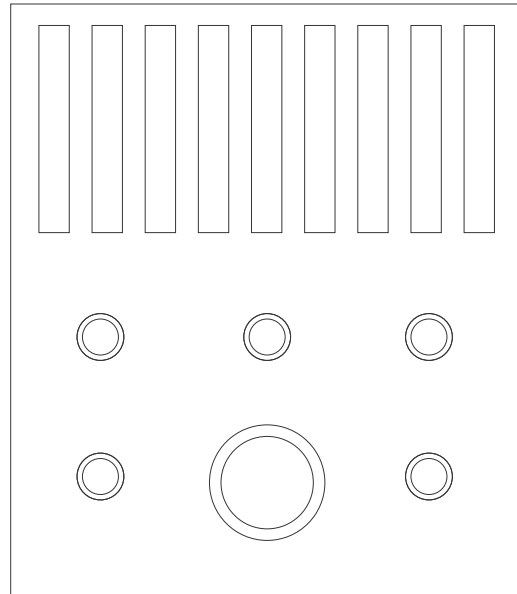

HP-65 Supply Connections

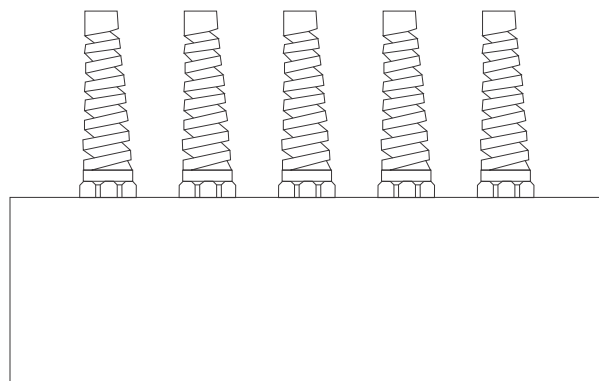

HP-125 Strain Relief for
Supply Connections

Installation

Electrical Connections

Connection terminals are located in the rear control box for output signals to the chemicals injection supply pump.

Do not attempt to increase fuse rating as this cause damage to the washer-extractor circuitry.

Terminals SUPPLY 1 through SUPPLY 8 provide signals for external chemical supply pumps. The signal is a maximum 1 amp at 24V 50/60Hz.

Any injection system pump, which requires 24-220V AC must be powered by a separate external power source.



Attempting to obtain power from the machine terminals may damage the machine circuit and/or the chemical injection system. Consult the chemical injection supply system instructions for operational details.

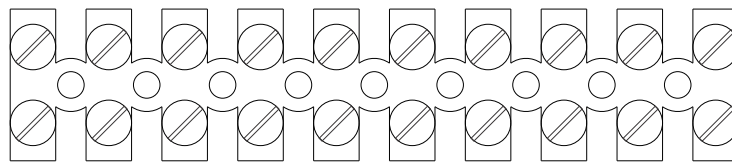

1 2 3 4 5 6 7 8 COM

CHEMICAL INJECTION SIGNALS

24VAC, 1.0A MAX TOTAL LOAD

Installation

Control Function Test

The machine should be cleaned after the installation is complete. A function test should then be executed on the unloaded machine as follows:

1. Check the proper supply for such characteristics as correct voltage, phase, and cycles to be certain they are correct for the machine.
2. Open manual shut-off water valves to the machine.
3. Press Emergency Stop button.
4. Apply power to the machine.
5. Release the Emergency button.
6. Check the door interlock before starting the machine.
 - a. Attempt to start the machine with the door open. The machine should not start with the door open.
 - b. Close the door without locking it and attempt to start the machine. The washer should not start with the door

unlocked.

- c. Close and lock the door and start a cycle. Attempt to open the door while the cycle is in progress. The door should not open.

If the door lock and interlock are not functioning properly, call a service technician.

7. For standard processing, select program 30 by pressing key 3 and key 0 on the keypad. Then press enter and the Start key. Run the complete program, checking operation of water inlet valves, drain, and extract functions. Program 30 is a test program that goes through most machine functions.

8. Cylinder rotation must be counter-clockwise in the extract step. If rotation is not correct, disconnect the power to the machine. A qualified technician must reverse any two leads between the AC drive and the motor. See figure.

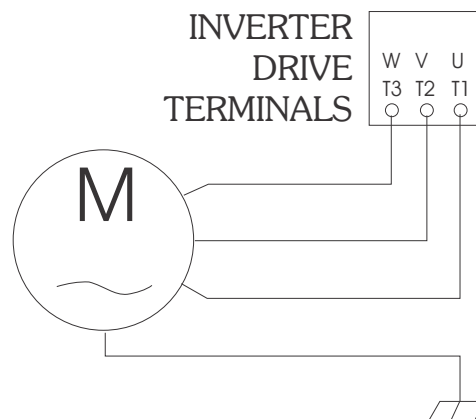

Operation

HP-65 Door Lock Operation

The HP-65 door lock system uses a "push-to-open / push-to-close" style mechanism which differentiates it from any other door lock in the industry. This design was developed as a result of analyzing the shortcomings of other door lock mechanisms on the market. It hence has many fundamental safety & mechanical advantages.

Operation

Opening & Closing

To open the door the machine must not be running a wash program -- "Program N" should be displayed on the EL6. Simply push and release the door handle with the palm of your hand. As you push the handle in the door lock solenoid will energize and the pin will retract and release the door. Then as you release the pressure on the handle the door will be free and you can pull it open. To close the door swing it closed, then push the handle firmly until you hear the solenoid engage, releasing the door lock pin to lock the door. When you start a wash program the door lock is securely disabled so that the door cannot be accidentally opened.

Periodic Maintenance

- ▶The door should be tested every day for safe operation by trying to start a program with the door open. If the machine will begin operation in this state it should immediately be removed from service, locked out, and a qualified service technician called to repair it.
- ▶If the door lock is malfunctioning in any way, the machine should immediately be removed from service, locked out, and a qualified service technician called to repair it.
- ▶The door lock pin and handle hinge should be lubricated with "silicon spray lube" monthly. This product is available at almost any auto parts store. This procedure does not require any disassembly.
- ▶The door handle nose bushing should be checked for wear and cracking monthly. It should be replaced when it is cracked, missing, or worn out.
- ▶The door lock tongue and lock pin alignment should be checked monthly and adjusted as needed.
- ▶For detailed instructions on door alignment, request TSB009 when contacting technical service.

Maintenance

Routine Maintenance

Routine maintenance maximizes operating efficiency and minimizes downtime. The maintenance procedures described below will prolong the life of the machine and help prevent accidents.

Daily, weekly, monthly, and quarterly checklists are provided at the end of this section. Laminate the checklists to preserve them for repeated copying. Operators and technicians are encouraged to add checks specific to their machine's particular application. When possible, space is provided on the checklists for this purpose.

The following maintenance procedures must be performed regularly at the required intervals.



Install all panels that are removed to perform service and maintenance procedures. Do not operate the machine with missing guards or with broken or missing parts. Do not bypass any safety

devices!

Daily

1. Inspect water inlet valve hose connections on the back of the machine for leaks.
2. Inspect steam hose connections for leaks, where applicable.
3. Verify that insulation is intact on all external wires and that all connections are secured. If bare wire is evident, call a service

technician.

4. Check door interlock before starting operation:

- a. Attempt to start the washer with the door open. The washer should not start with the door open.

- b. Close the door without locking it and attempt to start the machine. The machine should not start with the door open.

- c. Close and lock the door and start a cycle. Attempt to open the door while the cycle is in progress. The door should not open. If manual latch is moved out of position the machine should stop.

If the door lock and interlock are not functioning properly, call a service technician.

End of the day

1. Clean the door gasket of residual detergent and foreign matters.
2. Clean the automatic supply dispenser and the lid inside and out with mild detergent. Rinse with clean water.
3. Clean the washer's top, front and side panels with mild detergent. Rinse with clean water.
4. Leave loading door open at the end of each day to allow moisture to evaporate.

Maintenance

Routine Maintenance

NOTE: Leave loading door open at end of each complete cycle to allow moisture to evaporate. Unload the machine promptly after each completed cycle to prevent moisture build up.

Weekly

1. Check the machine for leaks.
 - a. Start an unloaded cycle to fill the machine.
 - b. Verify that door and door gasket do not leak.
 - c. Verify that the drain valve is operating. If water does not leak out during the prewash segment, drain valve is closed and functioning properly.
2. Clean the AC drive box air filters.
 - a. Snap off the external plastic cover which contains the filter. Remove the foam filter from the cover.
 - b. Wash the filter in a mild soap solution or vacuum it clean.

Monthly

NOTE: Disconnect power to the machine at its source before performing the monthly maintenance procedures.

1. Each month or after every 200 hours of operation, lubricate bearing and seals. See instructions on the machine.
 - a. Use a premium grade lithium based

#2 grease. Never mix two types of grease, such as petroleum and silicone.

- b. Pump the grease gun slowly, permitting only the following number of strokes:
 1. Bearing grease fitting, 2 strokes
 2. Seal grease fitting, 1 stroke.

Do not pump the grease gun if grease comes out of the bearing housing. This can result in over lubrication, causing damage to bearings and seals.

2. If the machine is provided with automatic lubricators, check that they are injecting grease. Normally they last for approximately one year. Mark new lubricators with installation date
3. Clean the AC drive fins:
 - a. Remove the AC drive box cover.
 - b. Blow the fins clean using compressed air at a pressure of 60-90 psi (4-6 Bar) or by using canned compressed air. Use care to avoid damaging cooling fan or other components.

NOTE: No amount of visible foreign matter should be allowed to accumulate on fins or the finger guard.

4. Use the following procedures to determine if V-belts require replacement or adjustment. Call a qualified service technician in either case.
 - a. Check V-belts for uneven wear and frayed edges.

Maintenance

Routine Maintenance

b. After disconnecting power to the machine and removing all panels necessary for access to the drive belts, use the following method to verify that the V-belts are properly tensioned. Belt tensioning is straightforward, and accomplished by loosening the tension adjusting bolts and adjusting the belts to the proper tension. Then the bolts should be tightened. See figure.

c. Verify that V-belts are properly aligned by checking pulley alignment. Place a straightedge across both pulley faces. The straight edge should make contact with the pulleys in four places. See figure.

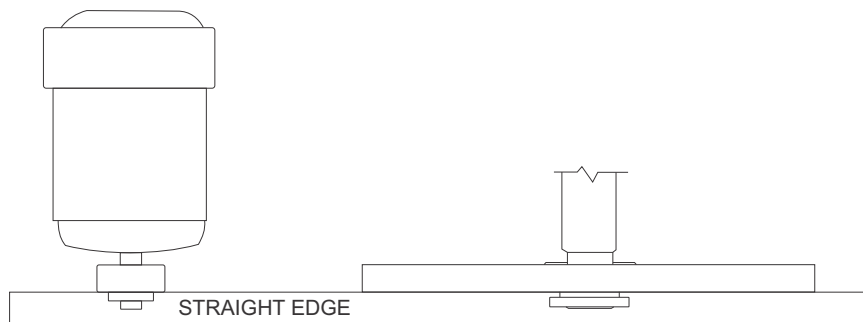
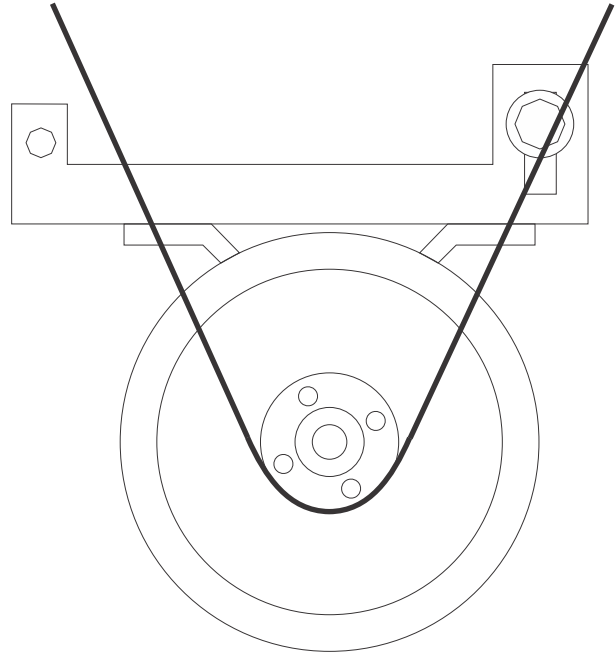

Maintenance

Routine Maintenance

5. Remove back panel and check overflow hose and drain hose for leaks.

6. Unlock the hinged lid and check the supply dispenser hoses and hose connections.

7. Clean inlet hose filter screen:

- a. Turn water off and allow valve to cool, if necessary.
- b. Unscrew inlet hose and remove filter screen.
- c. Clean with compressed air and reinstall. Replace if worn or damaged.

8. Tighten motor mounting bolt lock nuts and bearing bolt lock nuts, if necessary.

9. Use compressed air to clean lint from motor.

10. Clean external water and steam filters.

Quarterly

NOTE: Disconnect power to the machine before performing the quarterly maintenance procedures.

1. Tighten door hinges and fasteners, if necessary.

2. Tighten anchor bolts, if necessary.

3. Check all painted surfaces for bare metal (matching paint is available from the manufacturer.)

a. If bare metal is showing, paint with primer or solvent-based paint.

b. If rust appears, remove it with sand paper or chemical means. Then paint with primer or solvent-based paint.

4. Clean steam filter, where applicable. See picture of steam filter.

1. Turn off steam supply and allow time for the valve to cool if necessary.

2. Unscrew nut.

3. Remove element and clean.

4. Replace element and nut.

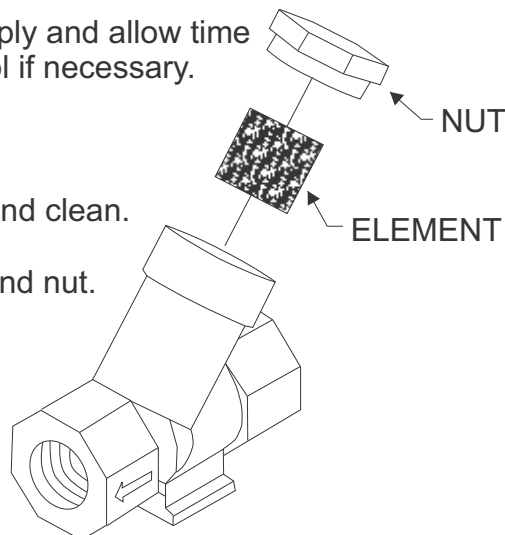

Maintenance

Routine Maintenance

Care of stainless steel

Maintain the natural beauty of stainless steel and prolong its service life by following these steps.

1. Ordinary deposits of dirt and grease can be removed with detergent and water. The metal should be thoroughly rinsed and dried after washing. Periodic cleaning will help to maintain the bright surface appearance and prevent corrosion.

2. Contact with dissimilar metal should be avoided whenever possible. This will help prevent galvanic corrosion when salty or acidic solutions are present.

3. Salty or acidic solutions should not be allowed to evaporate and dry on stainless steel. They may cause corrosion. Ensure that the stainless steel is wiped clean of acidic solution residues.

4. Deposits that adhere to the stainless steel should be removed, especially from crevices and corners. When using abrasive cleaners, always rub in the direction of the polish lines or grain of the stainless steel to avoid scratch marks. Never use ordinary steel wool or steel brushes on the stainless steel. Use stainless steel wool or soft non-metal bristle brushes.

5. If the stainless steel appears to be rusting the source of the rust may actually be an iron or steel part not made of stainless steel, such as a nail or screw. One remedy is to paint all carbon steel parts with a heavy protective coating. Stainless steel fasteners should be used

when possible.

6. Discolorations or heat tint from overheating may be removed by scouring with powder or by employing special chemical solutions.

7. Sanitizers or sterilizing solutions should not be left in stainless steel equipment for prolonged periods of time. They often contain chlorine, which may cause corrosion. The stainless steel should be cleaned and rinsed thoroughly of any solution containing chlorine.

8. When an external chemical supply system is used, make certain that no siphoning of chemicals occurs when the washer-extractor is not in use. Highly concentrated chemicals can cause severe damage to stainless steel and other components within the machine. Damage of this kind is not covered by the manufacturer's warranty. Locate the pump below the washer's injection point to prevent siphoning of chemicals into the machine.

Decommissioning

Decommissioning

In the event that the machine must be decommissioned, follow the following steps:

1. Remove the chemical injection supply system, if applicable.

a. Have a qualified electrician disconnect power to the chemical injection supply system and the re-circulation pump at their source.

b. Using the manufacturer's instructions, carefully remove the chemical injection supply system from the machine. Make certain that no chemicals supplies come in contact with skin or clothing.

2. Clean interior of machine, both basket and shell.

a. Flush supply dispenser with water.

b. Run a short rinse cycle to clean chemical residues from the interior of the machine.

3. Disconnect electrical power.

a. Shut off main power supply at the breaker box or main control panel.

b. Do not attempt to disconnect power supply wires from power supply. Have a qualified electrician disconnect power to machine at its source.

4. Disconnect hoses.

a. Disconnect drain hose from sump, gutter, or drain.

b. Turn off water supply. Disconnect individual hot and cold water inlet hoses from the machine

c. Disconnect the compressed air

supply to the machine.

d. Allow time for residual water in the machine to drain. Then disconnect drain hoses from the machine.

e. Disconnect necessary plumbing on the re-circulation system, if applicable.

5. Disconnect steam hoses, if applicable

a. Turn off steam supply and allow time for the valve to cool.

b. Disconnect steam hose from machine.

6. Remove the machine from its foundation pad.

a. Keep all panels in place to provide stability when moving the machine.

b. Verify that door is closed and secure

c. Loosen and remove anchor bolts holding the machine base to the floor

d. Break the grout seal at each corner of the machine, using a crowbar.

e. Place the machine on skid and bolt the frame to the skid. This will facilitate the removal of the machine on to a truck.

7. Recycle.

The manufacturer uses the highest quality material in their products so that those material may be recycled at the end of the product's service life.

