

Earthquake®

6014V CRT ROTOTILLER

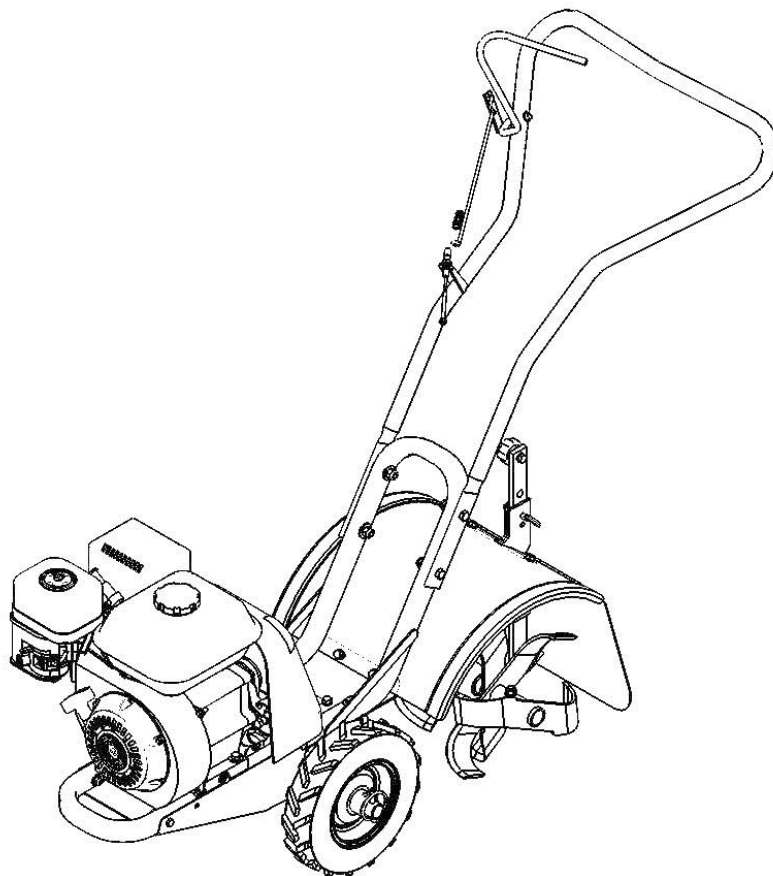

6014V
VIPER ENGINE
196 CC



GetEarthquake.com



OM6014

Rev. 7/13/09

© 2009 Ardisam, Inc.

All Rights Reserved. Printed in USA.

INTRODUCTION

THANK YOU ...

for purchasing an Earthquake® counter rotating rear-tine rototiller from Ardisam, Inc. We have worked to ensure that this rear-tine rototiller meets high standards for usability and durability. With proper care, your rototiller will provide many years of service. Please take the time to read this manual carefully to learn how to correctly operate and maintain your rototiller. This manual should be considered a permanent part of your rototiller. Due to continuous effort to perfect our product, certain procedures and specifications are subject to change without notice. Congratulations on your investment in quality.

CONTENTS

| | |
|----------------------------|-----------|
| Registration | 2 |
| Safety | 3-5 |
| Unpacking & Assembly | 6 |
| Features | 7 |
| Operation | 8-13 |
| Maintenance | 14-17 |
| Troubleshooting | 18-19 |
| Parts | 20-26 |
| Warranty | Back Page |

REGISTRATION

Record your model number and serial number in the space provided for easy reference. Fill out and mail the registration card located in your parts packet. Warranty is valid only if your completed registration card is received by Ardisam, Inc., within two weeks of the purchase date.

Model Number _____
Serial Number _____
Engine Serial Number _____
Date of Purchase _____
Place of Purchase _____

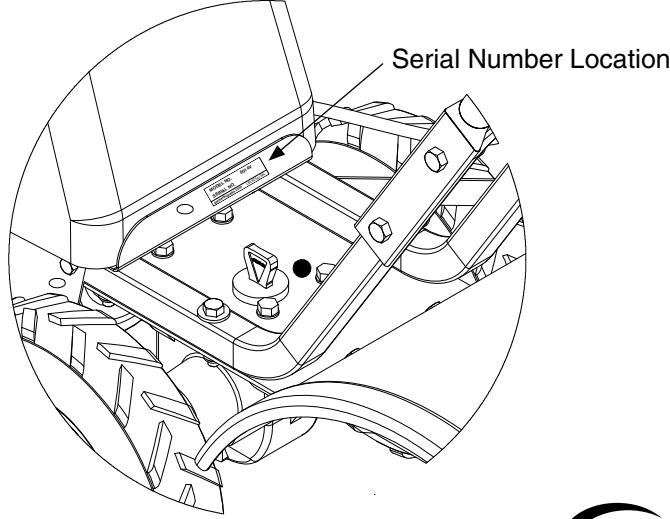

SAFETY

OWNER'S RESPONSIBILITY

Accurate assembly and safe and effective use of the rototiller is the owner's responsibility.

- Read and follow all safety instructions.
- Carefully follow all assembly instructions.
- Maintain the tiller according to directions and schedule included in this Earthquake operator's manual.
- Ensure that anyone who uses the tiller is familiar with all controls and safety precautions.

SPECIAL MESSAGES

Your manual contains special messages to bring attention to potential safety concerns, machine damage as well as helpful operating and servicing information. Please read all the information carefully to avoid injury and machine damage.

NOTE: General information is given throughout the manual that may help the operator in the operation or service of the machine.

IMPORTANT SAFETY PRECAUTIONS

Please read this section carefully. Operate the tiller according to the safety instructions and recommendations outlined here and inserted throughout the text. Anyone who uses this tiller must read the instructions and be familiar with the controls. Your tiller is equipped with a safety device that enables you to stop the wheels and tines quickly in an emergency. Learn how the drive safety control lever operates and how to control the tiller at all times.



This symbol points out important safety instructions which if not followed could endanger your personal safety. Read and follow all instructions in this manual before attempting to operate this equipment.

- Do not allow children to operate this rototiller. Keep small children away from the area being tilled. Do not allow adults to operate the tiller without proper instruction.

PREPARATION

- Dress appropriately when operating the tiller. Always wear sturdy footwear. Never wear sandals, sneakers, or open shoes, and never operate the tiller with bare feet. Do not wear loose clothing that might get caught in moving parts.
- Carefully inspect the area to be tilled and remove all foreign objects. Do not till above underground water lines, gas lines, electric cables, or pipes. Do not operate the tiller in soil with large rocks and foreign objects which can damage the equipment.
- Leave control lever in the neutral position before starting the engine.
- Handle fuel with care; it is highly flammable.
 - a. Use an approved fuel container.
 - b. Never add fuel to a running engine or hot engine.

DANGER

DANGER INDICATES A SERIOUS INJURY OR FATALITY WILL RESULT IF THE SAFETY INSTRUCTIONS THAT FOLLOW THIS SIGNAL WORD ARE NOT OBEYED.

WARNING

WARNING INDICATES A SERIOUS INJURY OR FATALITY COULD RESULT IF THE SAFETY INSTRUCTIONS THAT FOLLOW THIS SIGNAL WORD ARE NOT OBEYED.

CAUTION

CAUTION INDICATES YOU CAN OR YOUR EQUIPMENT CAN BE HURT IF THE SAFETY INSTRUCTIONS THAT FOLLOW THIS SIGNAL WORD ARE NOT OBEYED.

IMPORTANT

IMPORTANT INDICATES HELPFUL INFORMATION FOR PROPER ASSEMBLY, OPERATION, OR MAINTENANCE OF YOUR EQUIPMENT.

WARNING

YOU MUST READ, UNDERSTAND AND COMPLY WITH ALL SAFETY AND OPERATING INSTRUCTIONS IN THIS MANUAL BEFORE ATTEMPTING TO SETUP AND OPERATE YOUR ROTOTILLER.

FAILURE TO COMPLY WITH ALL SAFETY AND OPERATING INSTRUCTIONS CAN RESULT IN LOSS OF MACHINE CONTROL, SERIOUS PERSONAL INJURY TO YOU AND/OR BYSTANDERS, AND RISK OF EQUIPMENT AND PROPERTY DAMAGE. THE TRIANGLE IN THE TEXT SIGNIFIES IMPORTANT CAUTIONS OR WARNINGS WHICH MUST BE FOLLOWED.

CALIFORNIA PROPOSITION 65 WARNING

ENGINE EXHAUST FROM THIS PRODUCT CONTAINS CHEMICALS KNOWN TO THE STATE OF CALIFORNIA TO CAUSE CANCER, BIRTH DEFECTS, OR OTHER REPRODUCTIVE HARM.

- c. Fill fuel tank outdoors with extreme care. Never fill fuel tank indoors.
- d. Replace gasoline cap securely and clean up spilled fuel before restarting.
- Never attempt to make any adjustments while the engine is running.

OPERATION

- Never operate the tiller without guards, covers, and hoods in place.
- Never start the engine or operate the tiller with the wheels in the free-wheel position. Make sure the wheel lock pins are engaged through the wheel hubs and wheel axle. The wheels act as a brake to keep the tiller at a controlled speed. Disengage wheel lock pins to permit free-wheeling only when engine is stopped.
- Keep hands, feet, and clothing away from rotating parts. Keep clear of tiller tines at all times.
- Tines and wheels rotate when tiller is engaged in **forward**, tines and wheels rotate when the drive safety control lever, is pulled toward the handlebar. Releasing the drive safety control lever to the **neutral** position stops the wheels and tines.
- Use extreme caution when operating on or crossing gravel drives, walks, or roads. Stay alert for hidden hazards or traffic.
- After striking a foreign object, stop the engine, remove the wire from the spark plug, thoroughly inspect the tiller for any damage, and repair the damage before restarting and operating the tiller.
- If vegetation clogs the tines **STOP THE ENGINE AND DISCONNECT THE SPARK PLUG WIRE** before removing vegetation by hand.
- Engine muffler will be hot from operation. Do not touch it with bare skin or a severe burn may result.
- If the unit should start to vibrate abnormally, stop the engine and check immediately for the cause. Vibration is generally a warning of trouble.
- Do not run the engine indoors; exhaust fumes are deadly.
- Do not overload the machine capacity by attempting to till too deep at too fast a rate.
- Never operate the machine at high transport speeds on slippery surfaces. Look behind and use care when backing.

IMPORTANT

THE RIGHT AND LEFT SIDES OF YOUR ROTOTILLER ARE DETERMINED FROM THE OPERATING POSITION AS YOU FACE THE DIRECTION OF FORWARD TRAVEL.

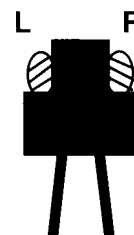

ENGINE IS SHIPPED FROM FACTORY WITHOUT OIL. YOU MUST ADD ENGINE OIL BEFORE STARTING ENGINE.

- Never allow bystanders near the unit.
- Use only attachments and accessories approved by the manufacturer of the tiller.
- Never operate the tiller without good visibility or light.
- Be careful when tilling in hard ground. The tines may catch in the ground and propel the tiller backward. If this occurs, let go of the handlebars and do not restrain the machine.
- Take all possible precautions when leaving the machine unattended. Disengage all control levers, stop the engine, wait for all moving parts to stop, and make certain guards and shields are in place.
- When leaving the operating position for any reason:
 - shut off the engine.
 - wait for all moving parts to stop.

MAINTENANCE AND STORAGE

- Keep machine, attachments, and accessories in safe working condition.
- Check shear bolts, engine mounting bolts, and other bolts at frequent intervals for proper tightness to be sure the equipment is in safe working condition.
- To prevent accidental starting, always disconnect and secure the spark plug wire from the spark plug before performing tiller maintenance.
- Never run the engine indoors. Exhaust fumes are deadly.
- Always allow muffler to cool before filling fuel tank.
- Never store equipment with gasoline in the tank inside a closed building where fumes may reach an open flame or spark. Allow the engine to cool before storing in any building.
- Always refer to the operator's guide instructions for important details if the tiller is to be stored for an extended period.
- Add a fuel stabilizer to gas tank and run for 10-15 minutes to prevent fuel from gumming up during an extended storage period.

SAFETY DECALS

This rototiller unit has been designed and manufactured to provide you with the safety and reliability you would expect from an industry leader in outdoor power equipment manufacturing.

Although reading this manual and the safety instructions it contains will provide you with the necessary basic knowledge to operate this equipment safely and effectively, we have placed several safety labels on the tiller to remind you of this important information while you are operating the unit.

These important safety labels are illustrated below, and are shown here to help familiarize you with the location and content of the safety messages you will see as you perform normal tilling operations. Please review these labels now. If you have any questions regarding their meaning or how to comply with these instructions, reread the complete safety instruction text on the preceding pages, or contact your local dealer.

Should any of the safety labels become unreadable because of being worn, faded, or otherwise damaged during the use of your tiller, please use the part number information provided to order a replacement label from your local authorized dealer.

The safety labels are easily applied, and will act as a constant visual reminder to you, and others who may use the equipment. Follow the safety instructions necessary for safe, effective operation of your rototiller.

⚠ WARNING

AVOID SERIOUS INJURY

- Read operator's manual(s) before operating.
- Know the location and function of all controls.
- Keep all shields and guards in place and working while running.
- Never allow children to operate tiller.
- Dress appropriately — wear sturdy footwear.
- Carefully inspect area to be tilled — remove large rocks and other foreign objects.
- Do NOT till above underground electric, water, gas, or other utility lines and pipes.
- STOP THE ENGINE AND DISCONNECT THE SPARK PLUG WIRE before removing debris or servicing unit.
- When leaving the operating position for any reason:
 - shut off the engine.
 - wait for all moving parts to stop.

⚠ WARNING

WHEELS ACT AS BRAKES

- Never start or operate tiller with wheels in the Free-Wheel position. Make sure wheel lockouts are engaged through wheel hubs and axle.
- Wheels act as brakes to keep the tiller at a controlled speed. Disengage wheel lockouts ONLY when engine is stopped.

OPERATION

REFER TO OPERATOR'S MANUAL FOR DETAILED OPERATING INSTRUCTIONS TO START:

1. Release drive control levers to neutral position.
2. Lower the drag stake so that tines do not touch the ground.
3. Check position of wheels and wheel lockouts.
4. Slide choke control to choke position.
5. Move throttle control lever to fast position.
6. Pull starter rope.

LBL516AA

Part No. LBL516AA
WARNING INSTRUCTIONS
Hood Decal

⚠ WARNING!

DO NOT START ENGINE UNLESS BELT COVER IS ATTACHED. KEEP HANDS, FEET, AND CLOTHING AWAY FROM MOVING BELTS AND PULLEYS. FAILURE TO COMPLY COULD RESULT IN INJURY. SEE OWNER'S MANUAL FOR FULL SAFETY INSTRUCTIONS.

LBL516C

Part No. LBL516C
WARNING
Belt Cover Decal

⚠ DANGER



AVOID INJURY FROM ROTATING TINES!

Keep hands, feet, and clothing away.

- Tines rotate when tiller is engaged in forward or reverse.
- Tines and wheels rotate when drive control levers are pulled toward the handle bar. Do not operate both drive control levers at the same time.
- In reverse, tines and wheels rotate when the reverse control lever is pulled up
- **Releasing the drive control levers to the neutral position stops the wheels and tines.**

LBL516J

Part No. LBL516J
TINES DANGER
Hood Flap Decal

UNPACKING AND ASSEMBLY

Your rototiller comes fully assembled except for a few parts. The following instructions will help you unpack your tiller and assemble and adjust your tiller's depth regulator lever, cable tension and handlebar height. You will need 2- 9/16" wrenches.

UNPACK TILLER

1. Open top of carton and remove handlebar assembly.
2. Find parts packet. Parts packet contains:
 - 4- 3/8-16 x 1 3/4" hex head bolts
 - 4- 3/8-16 locknuts
 - 1- 5/16-18 x 3/4" hex head bolt
 - 1- detent pin
 - 1- five star knob
 - 4- 3/8" flat washers
3. Cut open end of carton and remove machine by:
 - a. Putting loose wheels onto machine with lock pin disengaged from wheel.
 - b. Roll tiller from carton.

ATTACH HANDLEBAR TO TILLER

1. Place handlebar stems on outside of lower handlebar mount and align lower holes. **(SEE FIGURE 1)**
2. Insert one 3/8-16 x 1 3/4" bolt for each side in lower holes at the desired handlebar height. Put 3/8" flat washers onto bolts.
3. Start 3/8-16 nuts on each bolt.
4. Insert one 3/8-16 x 1 3/4" bolt for each side in upper holes. Put 3/8" flat washers on to bolts.
5. Start 3/8-16 nuts on each bolt.
6. Tighten all 3/8-16 nuts.

FILL ENGINE CRANKCASE

1. Add oil according to engine manual. **Do not overfill.** Use a clean, high quality detergent oil. Container must be marked A.P.I. Service SF - SJ. Use no special additives with recommended oils. **Do not mix oil with gasoline.** Oil level must be full. Check the oil level by removing oil fill plug. Oil level should be up to the bottom of the fill plug opening.
2. Always check oil level before starting engine. Refer to engine manual for capacity and type of oil to use.

IMPORTANT

THE RIGHT AND LEFT SIDES OF YOUR ROTOTILLER ARE DETERMINED FROM THE OPERATING POSITION AS YOU FACE THE DIRECTION OF FORWARD TRAVEL.

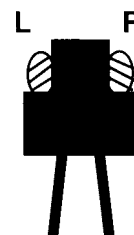

ENGINE IS SHIPPED FROM FACTORY WITHOUT OIL. YOU MUST ADD ENGINE OIL BEFORE STARTING ENGINE.

TILLER TRANSMISSION IS SHIPPED FROM FACTORY WITH THE PROPER AMOUNT OF LIQUID GREASE.

CAUTION

DO NOT TRY TO LIFT THE ROTOTILLER FROM THE CARTON.

DO NOT ADD ENGINE OIL INTO GEAR CASE DIPSTICK HOLE.

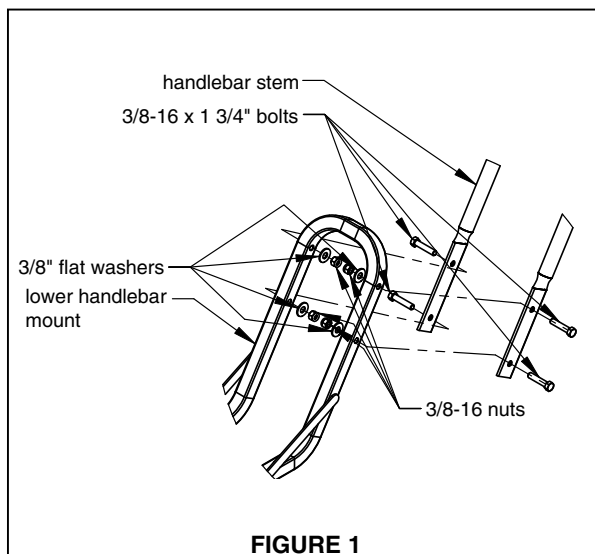
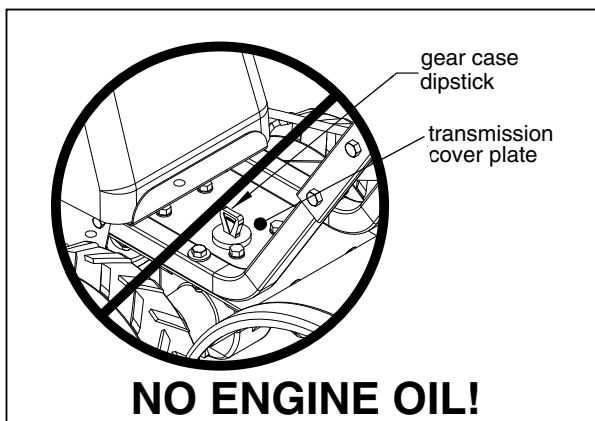

FEATURES

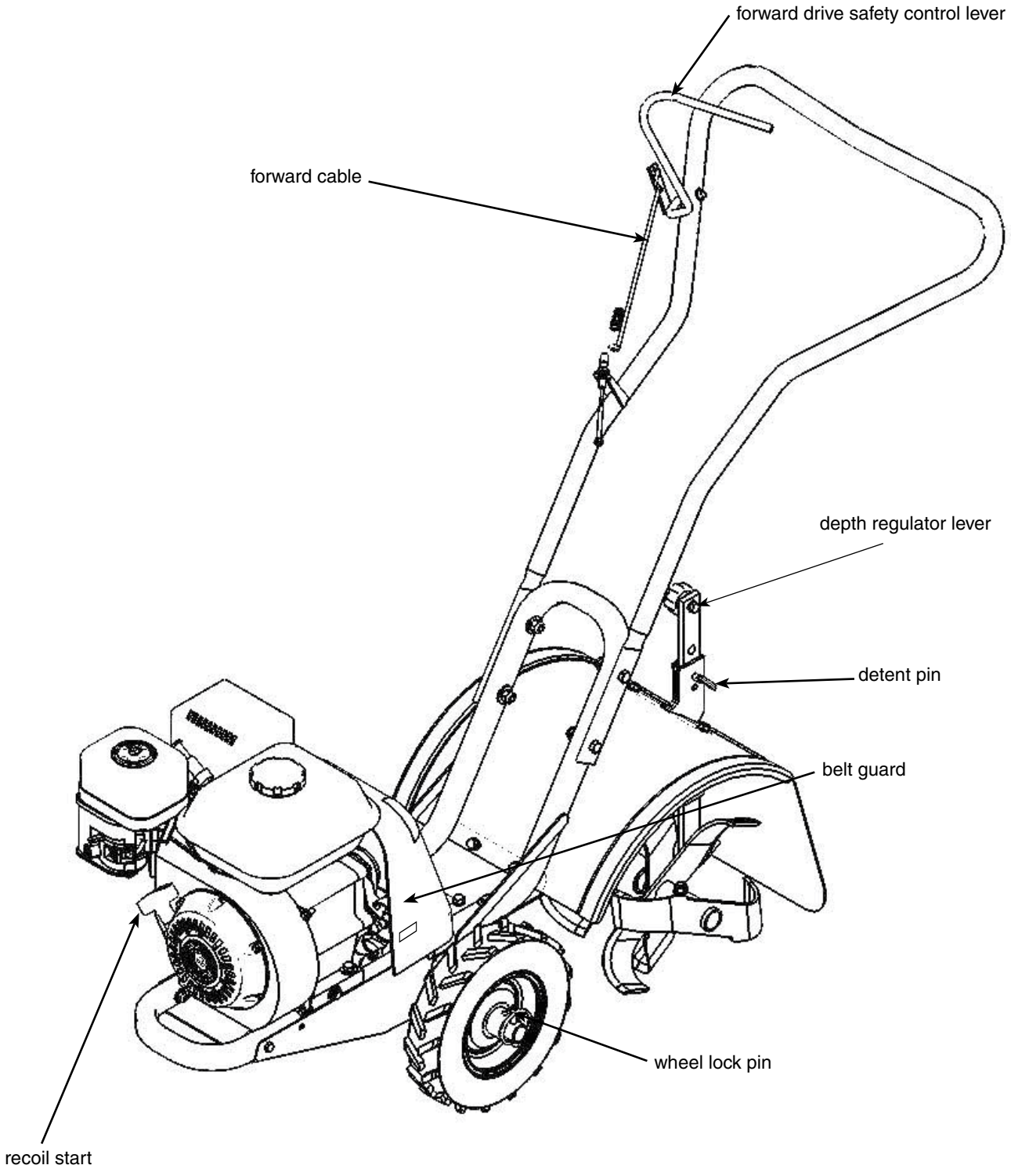

OPERATION

PRE-START INSPECTION

1. Make sure all safety guards are in place and all nuts and bolts are secure.
2. Check oil level in engine crankcase. See your engine manual for procedure and specifications.
3. Inspect air cleaner for cleanliness. See your engine manual for procedure.
4. Check the fuel supply. Fill the fuel tank no closer than 1 inch from top of tank to provide space for expansion. See your engine manual for fuel recommendations.
5. Be sure spark plug wire is attached and spark plug is tightened securely.
6. Check position of wheels and wheel lock pins.
7. Check depth regulator lever position.
8. Examine underneath and around engine for signs of oil or fuel leaks.
9. Inspect fuel hoses for tightness and fuel seepage.
10. Look for signs of engine damage.
11. Remove excessive debris from muffler area and recoil starter.

START-UP

The controls required to start and run the rototiller are located on the engine and are marked "Choke" and "Throttle".

A more detailed description of engine operation and all related precautions and procedures can be found in the engine manufacturer's manual that accompanies each tiller.

COLD STARTS

1. Move choke lever to full choke position.
2. Move throttle lever to "start".
3. Pull starting rope out slowly one time and allow to return normally.
4. Pull starting rope out rapidly, and allow rope to return normally.
5. When engine starts, gradually move choke lever to "no choke" position and increase throttle speed.

RESTARTING A WARM ENGINE

Restarting an engine that is already warm from previous running does not normally require use of the choke.

1. Move throttle lever to "start" position.
2. Pull starting rope out rapidly until engine starts. Allow rope to return normally. Repeat until engine starts.
3. Adjust throttle speed to "high" for best tiller action.

CAUTION

PLEASE DO NOT START YOUR TILLER UNTIL YOU HAVE READ THE MANUAL THAT CAME WITH YOUR ENGINE, AND THE SECTIONS IN THIS MANUAL TITLED CONTROLS, ADJUSTMENTS AND SAFETY. IF YOU HAVE READ THESE, FOLLOW THE STEPS BELOW TO START YOUR TILLER. ALWAYS PERFORM THIS PRE-START CHECKLIST BEFORE STARTING THE ENGINE.

WARNING

GASOLINE IS HIGHLY FLAMMABLE AND MUST BE HANDLED WITH CARE. NEVER FILL THE TANK WHEN THE ENGINE IS HOT OR RUNNING. ALWAYS MOVE OUTDOORS TO FILL THE TANK.

WHEELS MUST ALWAYS BE LOCKED IN THE TILLING POSITION WHEN ENGINE IS RUNNING. DO NOT OPERATE THE TILLER WITH THE WHEEL LOCKOUTS UNLOCKED. ALWAYS SET THE WHEELS IN TILLING POSITION BEFORE STARTING ENGINE.

ALWAYS PUT THE DEPTH REGULATOR LEVER IN THE TRANSPORT POSITION BEFORE STARTING ENGINE. TINES SHOULD CLEAR THE GROUND.

IMPORTANT

ENGINE IS SHIPPED FROM FACTORY WITHOUT OIL. YOU MUST ADD ENGINE OIL BEFORE STARTING ENGINE.

DANGER

ALWAYS KEEP HANDS AND FEET CLEAR OF ROTATING MACHINE PARTS.

IDLE SPEED

Use the “low” position on the throttle lever to reduce stress on the engine when tilling is not being performed. Lowering the engine speed to “idle” will help extend the life of the motor, as well as conserve fuel and reduce the noise level of the equipment.

OPERATING SPEED

For normal tilling, set the throttle lever to “fast”.

SHUTTING DOWN

To stop the engine at any time, move throttle control to the off position. To stop wheels and tines at any time, release drive safety control levers to neutral position.

TILLING

1. Adjust the depth regulator lever to desired tilling depth.

NOTE: Raise depth regulator lever up one hole at a time, testing tiller operation after each raise. Raising depth regulator lever too high can result in loss of control of tiller!

2. Move the throttle control to **fast**.
3. Place the tiller in **forward** by pushing down on the drive safety control lever-this will engage the wheels and tines.

NOTE: You can slow the tiller's forward advance at any time by putting slight downward pressure on the handlebars. You can stop the tiller by releasing the drive safety control levers to the neutral position.

WARNING

TEMPERATURE OF MUFFLER AND NEAR BY AREAS MAY EXCEED 150° F. AVOID THESE AREAS.

DO NOT MOVE CHOKE CONTROL TO CHOKE TO STOP ENGINE. BACKFIRE OR ENGINE DAMAGE MAY OCCUR.

TO STOP WHEELS AND TINES AT ANY TIME, RELEASE DRIVE SAFETY CONTROL LEVERS TO NEUTRAL POSITION.

ALWAYS RELEASE DRIVE SAFETY CONTROL LEVERS TO NEUTRAL POSITION BEFORE ADJUSTING THE DEPTH OF THE REGULATOR LEVER.

DANGER

ENGINE AND SURROUNDING PARTS BECOME EXTREMELY HOT DURING NORMAL USE AND WILL CAUSE SERIOUS BURN INJURIES IF TOUCHED BEFORE THE ENGINE HAS COOLED.

ALLOW ENGINE TO COOL COMPLETELY BEFORE TOUCHING THESE HOT SURFACES.

IMPORTANT

PRACTICE OPERATING THE CONTROLS AND TILLER WITH TINES OUT OF GROUND BEFORE BEGINNING TO TILL. IT IS IMPORTANT THAT YOU KNOW HOW TO USE THE TILLER PROPERLY, KEEP CONTROL AT ALL TIMES, STOP THE TINES AND WHEELS FROM TURNING, AND STOP THE ENGINE IF NECESSARY. IF YOU DO NOT KNOW HOW TO DO THESE THINGS, READ THE CONTROLS, ADJUSTMENTS AND SAFETY SECTIONS BEFORE PROCEEDING.

DRIVE SAFETY CONTROL LEVER

FORWARD LEVER

Engages wheels and tines into forward.

Pulling the drive safety control lever toward the handlebar engages the wheels and tines. Releasing the lever stops the wheels and tines and brings the tiller to a complete stop.

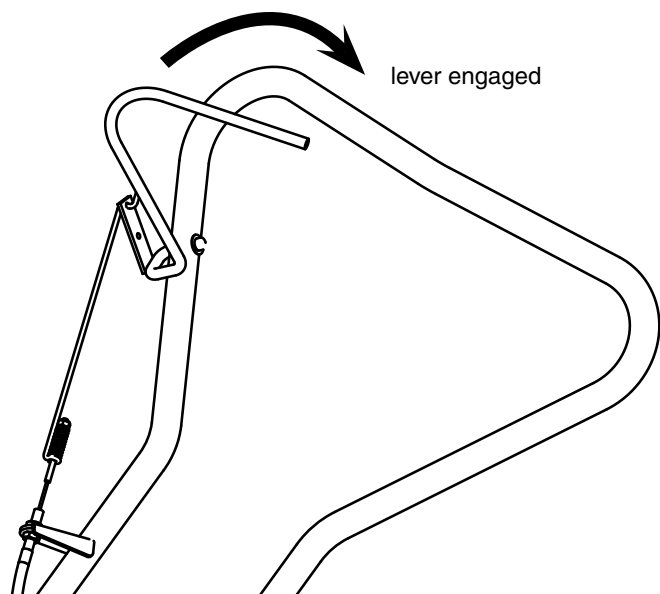

! CAUTION

THIS INFORMATION IS PROVIDED HERE ONLY TO INTRODUCE THE CONTROLS. DO NOT START THE ENGINE AT THIS TIME. STARTING AND OPERATING INSTRUCTIONS ARE GIVEN ON PAGE 8. PLEASE READ THIS SECTION AND ALL OPERATING AND SAFETY INSTRUCTIONS BEFORE STARTING YOUR TILLER.

- AS A SAFETY PRECAUTION, THE DRIVE SAFETY CONTROL LEVER WILL NOT LOCK IN THE FORWARD POSITION.
- TO STOP THE WHEELS AND TINES AT ANY TIME RELEASE THE DRIVE SAFETY CONTROL LEVER.

! WARNING

ENGINE SHOULD BE OFF BEFORE ADJUSTING ANY CONTROLS.

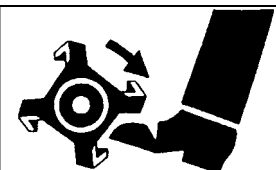

DANGER!

WHEEL LOCK PINS

Place wheels in tilling position.

1. Remove lock pin. Align hole in axle with hole in wheel hub. (SEE FIGURE 2)
2. Insert lock pin through holes, fold lock pin ring to secure pin to axle.
3. Firmly lock wheel and axle together before tilling.
4. Repeat for other wheel.

NOTE: Always have both wheel lock pins in or out. Do not operate tiller with only one wheel locked.

To place wheels in free-wheel position.

1. Remove lock pin. Slide wheel inward toward machine.
2. Insert pin in axle only.
3. Wheel should turn freely on axle.

WARNING

NEVER START ENGINE OR OPERATE TILLER WITH WHEELS IN FREE-WHEEL POSITION. THE FREE-WHEEL POSITION IS FOR TRANSPORTING THE TILLER LONG DISTANCES OVER LEVEL GROUND-DO NOT ATTEMPT TO MOVE THE TILLER UP OR DOWN STEEP GRADES IN THE FREE-WHEEL POSITION.

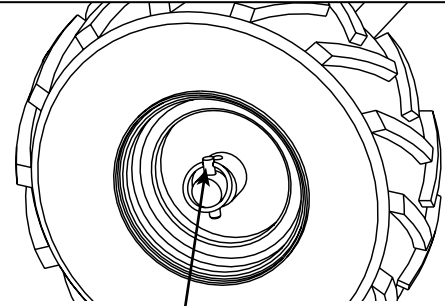

Wheel lock pin in free-wheel position.
(axle hole only)

FIGURE 2

DEPTH REGULATOR LEVER

Tilling depth is controlled by the height of the depth regulator lever.

To adjust tilling depth. (SEE FIGURE 4)

1. Remove detent pin.
2. Raise the depth regulator lever to position tines at chosen tilling depth.
3. Align hole in depth regulator lever with hole in depth regulator bracket and replace detent pin.

Depth Regulator Lever Down = Shallower tilling. Place the detent pin in the top hole of the depth regulator lever for shallowest tilling.

Depth Regulator Lever Up = Deeper tilling. Place the detent pin in the bottom hole of the depth regulator lever for deepest tilling.

BELT TENSION ADJUSTMENT

Proper belt tension is critical to good performance. After 1/2 hour of operation, all cables may have to be adjusted due to initial stretch. Thereafter, check tension after every 2 hours of operation.

To increase belt tension: (SEE FIGURE 5)

1. Loosen upper jam nut. Turn nut up cable in 1/8" increments.
2. Tighten lower jam nut.
3. Check adjustment.

This procedure can be repeated until conduit adjustment bolts are fully adjusted. If no more adjustment can be made, belt may have to be replaced.

WARNING

DO NOT ADJUST TILLING DEPTH UNLESS DRIVE SAFETY CONTROL LEVER IS RELEASED TO NEUTRAL POSITION.

ALWAYS SET THE DEPTH REGULATOR LEVER IN THE TRANSPORT POSITION BEFORE STARTING ENGINE, THAT IS, PLACE THE DETENT PIN IN THE HIGHEST HOLE OF THE DEPTH REGULATOR LEVER.

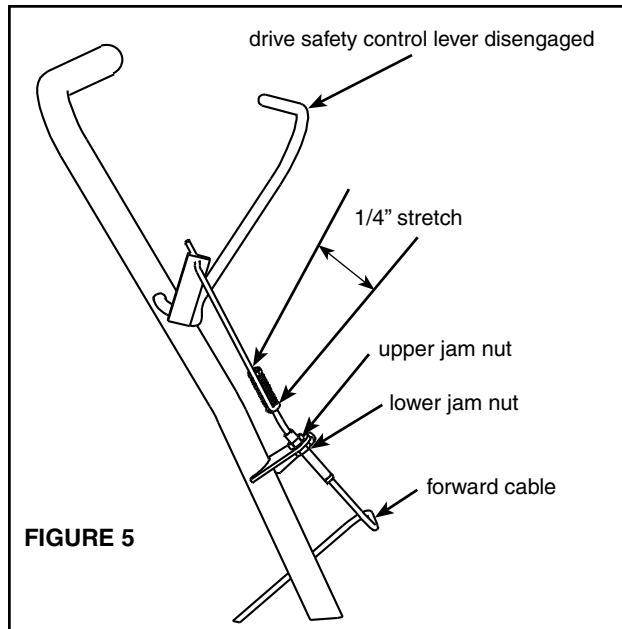
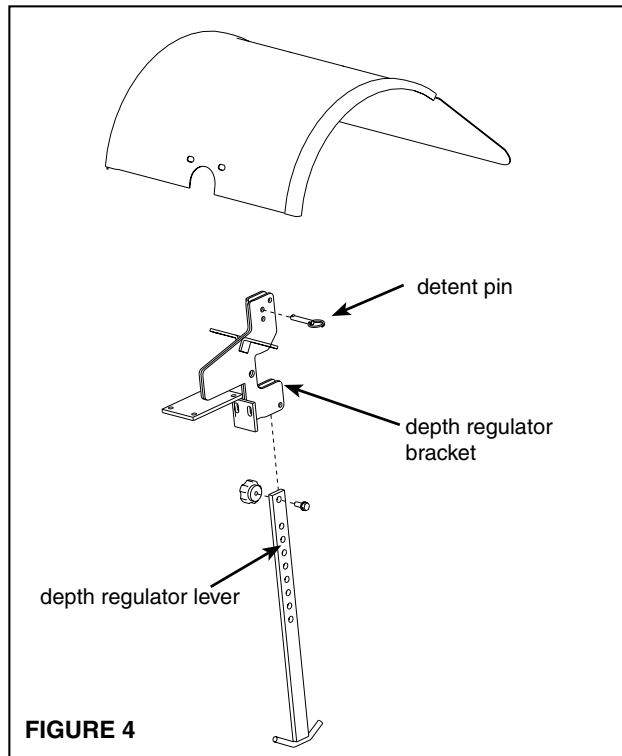

TILLING TIPS

The key to successful tilling is to begin with a shallow cut on the first pass, and then work an inch or two deeper on each successive pass.

- Tilling depth will vary with ground conditions.
- When beginning to till in unbroken ground or in extremely hard soil, set the detent pin in the highest hole of the drag stake (follow instructions under Tilling section). This will allow for shallow tilling. With the drag stake in this position, make several light passes over the area to be tilled. Reset for deeper depths with successive passes.
- If tiller jumps or skids uncontrollably, lower the drag stake by placing the detent pin in a higher hole. This will allow for shallower tilling. Hold firmly to the handlebars to control sudden lurches.

*Immediately release the drive control lever if the tines jam or you strike a foreign object. With drive control lever in neutral position, push throttle control to **stop** position to stop the engine. Disengage the spark plug wire. When tines have stopped, remove foreign objects and check for damage.*

CULTIVATING TIPS

If you plan to use your tiller for cultivating:

- Plant rows on 20" - 22" centers for ease of turning.
- Set the depth regulator lever with the detent pin in one of the higher holes. This will allow for shallow cultivation necessary to turn over weeds, and break up and aerate the soil.

WARNING

EXTREME CAUTION MUST BE TAKEN IN SELECTING TILLING DEPTH. IF YOU ATTEMPT TO TILL TOO DEEPLY FOR SOIL CONDITIONS, THAT IS, WITH THE DRAG STAKE IN TOO HIGH A POSITION, LOSS OF CONTROL COULD RESULT.

IF REMOVING MATERIAL FROM THE TINES BY HAND, STOP ENGINE AND REMOVE SPARK PLUG WIRE FIRST.

MAINTENANCE

MAINTENANCE SCHEDULE

Your rototiller has been designed and produced by the industry's leading manufacturer of outdoor power equipment to provide you years of reliable operation.

Keeping your tiller in top running condition will prolong its life, and help you obtain optimum performance.

Please read this normal care schedule, and note the recommended care operating intervals to extend the life of your unit.

| Maintenance Operation | Page | Before Each Use | 50 hours or Every Season |
|-----------------------------------|-------|-----------------|--------------------------|
| Change forward/reverse belt | 18 | | X |
| Engine maintenance | 19 | X | X |
| Check or fill engine crankcase | 19,EM | X | 2 |
| Check tiller transmission grease | 20 | X | |
| Check tire pressure | 20 | X | |
| Lubrication | 20 | X | |
| Clean tine axle shaft | 20 | X | |
| Lubricate wheel axle shaft | 21 | | X |
| Check throttle control adjustment | EM | | 1 |

EM = See engine manual

1 Adjust throttle control after first 3 hours of operation or if engine is hard to start or run-on occurs.

2 Change oil after first 5-8 hours of use, then after every 50 hours or every season. Change oil every 25 hours when operating under heavy load or in high temperatures.

SERVICING THE ROTOTILLER

The following information will help you make the necessary checks and perform the procedures required to follow the normal care recommendations made for your rototiller unit.

If you prefer, your local authorized dealer can make these checks and perform the required procedures for you.

⚠ WARNING

To prevent accidental starting:

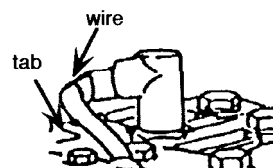

Engine must be turned off and cool, and spark plug wire must be removed and secured from spark plug before checking and adjusting engine or equipment.

CHANGE FORWARD/REVERSE BELT

1. Turn off engine. Engine must be cool.
2. Remove spark plug wire and secure from spark plug.
3. Remove belt guard. **(SEE FIGURE 6)**
 - remove the forward belt from the forward engine pulley:
 - gently pull the engine recoil rope to rotate the pulley.
 - with the pulley turning, force the forward belt out of the V-groove.
 - slide the belt free of the engine pulley.
 - pull the forward belt down and out of the way.
 - install new forward belt:
 - place forward belt in transmission pulley groove.
 - gently pull the engine recoil rope to rotate the pulley while forcing the forward belt into the V-groove.
4. Re-attach belt guard.
5. Attach spark plug wire.

CAUTION

DO NOT OPERATE TILLER BEFORE READING THE ENGINE MANUAL PROVIDED IN THE PARTS PACKET.

WARNING

TEMPERATURE OF MUFFLER AND NEAR BY AREAS MAY EXCEED 150° F. AVOID THESE AREAS.

IMPORTANT

ENGINE CAN OVERHEAT AND BECOME DAMAGED IF DEBRIS BLOCKS THE COOLING SYSTEM OR ROTATING SCREEN.

NEVER RUN ENGINE WITHOUT COMPLETE AIR CLEANER INSTALLED ON ENGINE.

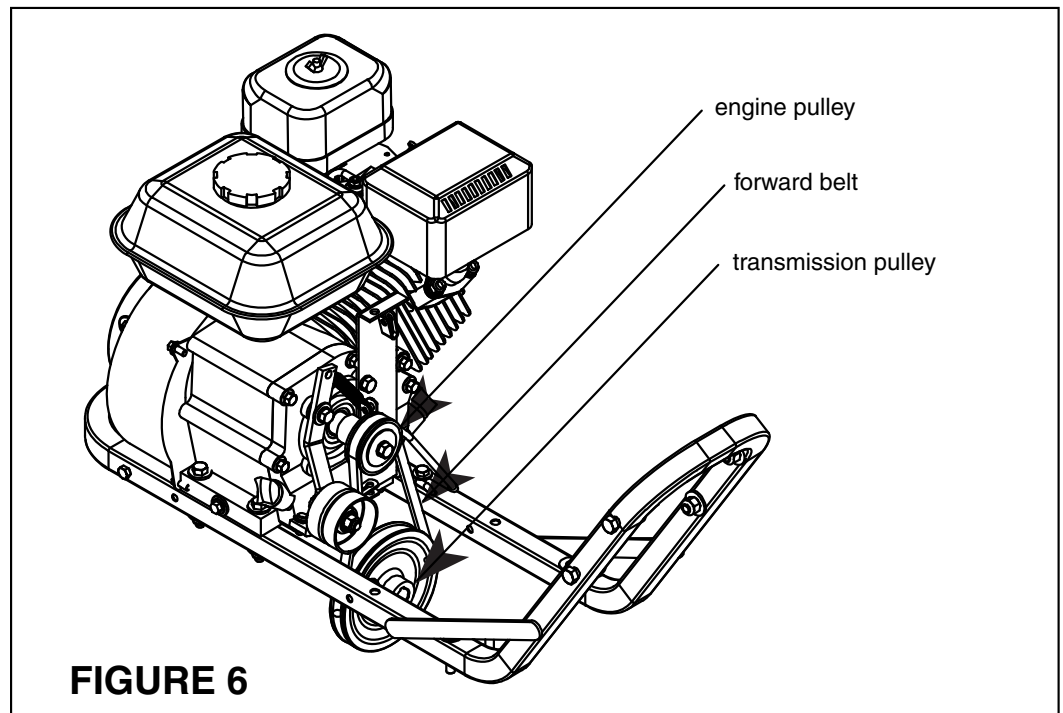

BELT REPLACEMENT PART #'S:

31315 (forward belt)

ENGINE MAINTENANCE

Refer to the engine manual included in your parts packet for information on engine maintenance. Your engine manual provides detailed information and a maintenance schedule for performing the following tasks:

1. Check oil level before each use or after every 8 hours of operation.
2. Change oil after first 5-8 hours of operation. Change oil while engine is warm. Refill with new oil of recommended grade.
4. Check spark plug yearly or every 100 hours of operation.
5. Service air cleaner.
6. Keep engine and parts clean.
7. Check engine and equipment often for loose nuts and bolts, keep these items tightened.

CHECK OR FILL ENGINE CRANKCASE

1. Add oil according to engine manual. **Do not overfill.** Use a clean, high quality detergent oil. Container must be marked A.P.I. Service SF - SJ. Use no special additives with recommended oils. **Do not mix oil with gasoline.** Oil level must be full. Check the oil level by removing oil fill plug. Oil level should be up to the bottom of the fill plug opening.
2. Always check oil level before starting engine. Refer to engine manual for capacity and type of oil to use.

CHECK TILLER TRANSMISSION GREASE

Check the grease level annually. To check the grease level:

1. Move tiller to level ground.
2. Remove grease level dipstick located between the handlebar mounts on the engine mount. Correct grease level is indicated between the high and low levels on the dipstick. **(SEE FIGURE 7)**
3. Replace grease level dipstick in the filler hole.
4. Note that the front wheel transmission and rear tine transmission are one common reservoir. When you add to the front transmission, you must wait a short period of time for the grease to flow rearward and equalize in both front and rear. The dipstick will read correctly on level ground for both gear units.
(Use Mystic 00 transmission fluid PN 1690)

CHECK TIRE PRESSURE

Recommended tire pressure is 20 PSI. If tires do not have equal pressure, tiller will pull to one side.

IMPORTANT

ENGINE IS SHIPPED FROM FACTORY WITHOUT OIL. YOU MUST ADD ENGINE OIL BEFORE STARTING ENGINE.

IMPORTANT

TILLER TRANSMISSION IS SHIPPED FROM FACTORY WITH THE PROPER AMOUNT OF LIQUID GREASE.

WHEN REPLACING GREASE, THE TILLER TRANSMISSION HOLDS 18-22 OUNCES. DO NOT OVERFILL.

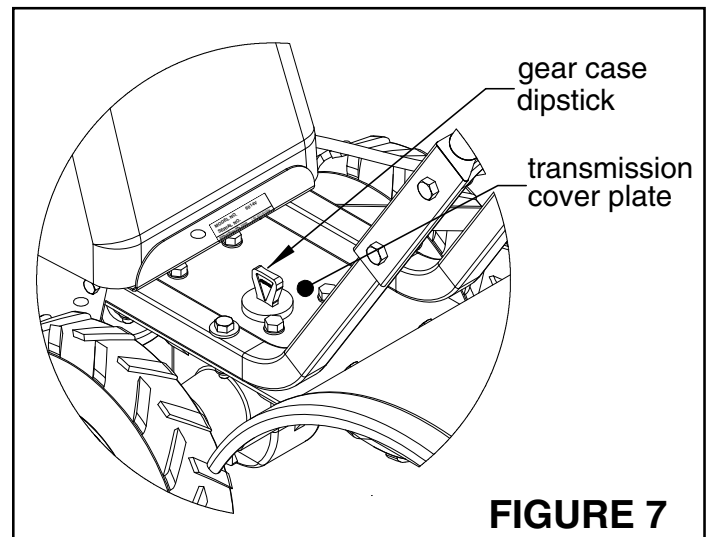

FIGURE 7

LUBRICATION

Proper lubrication of moving mechanical parts is critical for proper care and maintenance. Oil the moving parts at 10 hour intervals using a 30 weight oil.

CLEAN TINE AXLE SHAFT

1. Turn off engine. Engine must be cool.
2. Remove spark plug wire and secure from spark plug.
3. Tip the tiller forward. Block the tiller in position so that it rests on the engine mount and the tines are exposed.
4. Remove all vegetation, string, wire, and other material that may have accumulated on the axle between the inside set of tines and the seal on the transmission housing.
5. Tip the tiller back to a level position.
6. Replace spark plug wire.

STORAGE

PREPARE FOR STORAGE

Follow the steps below to prepare your tiller for storage. Read your engine manual for detailed instructions on preparing the engine for storage.

1. Protect wheels and axles from rust:
 - Remove lock pin and slide wheel off hub.
 - Coat the axles lightly with axle grease.
 - Slide wheel back on hub and insert lock pin.
2. Drain fuel system completely following engine manufacturer's instructions or add fuel stabilizer to prevent fuel from gumming up during extended storage period.
3. While engine is still warm, drain the oil from the engine. Refill with fresh oil of the recommended grade.
4. Clean external surfaces, engine and cooling fan.
5. Remove spark plug, pour one ounce of SAE 30 oil into spark plug hole.
6. Plug hole and pull starter cord slowly to distribute oil evenly in cylinder head area.
7. Reinstall spark plug.
8. Transport unit to a suitable storage location. If you have chosen to use a fuel stabilizer and have not drained the fuel system, follow all safety instructions storage precautions in this manual to prevent the possibility of fire from the ignition of gasoline fumes. Remember, gasoline fumes can travel to distant sources of ignition and ignite, causing risk of explosion and fire.
9. If there is any possibility of unauthorized use or tampering, remove the spark plug and store it in a safe place before storing the rototiller unit. Be sure to plug the spark plug hole to prevent foreign material from entering.

WARNING

DO NOT STORE TILLER IN AN UNVENTILATED AREA WHERE FUEL FUMES MAY REACH FLAME, SPARKS, PILOT LIGHTS OR AN IGNITED OBJECT. DRAIN FUEL OUTDOORS AWAY FROM ANY IGNITION SOURCES. USE ONLY APPROVED FUEL CONTAINERS.

TROUBLESHOOTING

TROUBLESHOOTING GUIDE

While normal care and routine maintenance will extend the life of your rototiller, prolonged or constant use may eventually require that service be performed to allow it to continue operating properly. The troubleshooting guide below lists the most common problems, causes and remedies.

WARNING

PRACTICE SAFETY AT ALL TIMES. ENGINE MUST BE TURNED OFF AND ALLOWED TO COOL, AND SPARK PLUG WIRE MUST BE DISCONNECTED AND SECURED BEFORE ATTEMPTING ANY MAINTENANCE OR REPAIR.

FAILURE TO COMPLY WITH THIS SAFETY REQUIREMENT CAN RESULT IN SERIOUS PERSONAL INJURY TO YOU OR BYSTANDERS.

| PROBLEM | REMEDY/ACTION |
|--|--|
| Engine will not start | <ul style="list-style-type: none"> • Add gas to gas tank. • Connect spark plug wire to spark plug • Throttle must be positioned at choke for a cold start |
| Engine runs rough, floods during operation | <ul style="list-style-type: none"> • Clean or replace air cleaner |
| Engine is hard to start | <ul style="list-style-type: none"> • Drain old fuel and replace with fresh. Use gas stabilizer at end of season • Make sure spark plug wire is securely attached to spark plug • Drive safety control levers must be released to neutral position to start the engine |
| Engine misses or lacks power | <ul style="list-style-type: none"> • Raise the tines for shallow tilling by lowering the depth regulator lever • Remove and clean fuel tank • Clean or replace air cleaner • Improper carburetor adjustment, take to authorized engine service center • Replace spark plug and adjust gap • Drain and refill gas tank and carburetor |
| Engine will not stop when throttle control is positioned at stop | <ul style="list-style-type: none"> • See engine manual to check and adjust throttle linkage |
| Tiller moves forward during starting | <ul style="list-style-type: none"> • Drive safety control levers must be released to neutral position to start the engine |
| Tiller is difficult to control when tilling (machine jumps or lurches forward) | <ul style="list-style-type: none"> • Lock wheels in tilling position • Raise the tines for shallower tilling by lowering the depth regulator lever |
| Tines turn, wheels do not turn | <ul style="list-style-type: none"> • Lock wheels in tilling position • Internal transmission failure, see your dealer |
| Tines turn, wheels turn, tiller does not move | <ul style="list-style-type: none"> • Lower the tines for deeper tilling by raising the depth regulator lever |

| PROBLEM | REMEDY/ACTION |
|--|---|
| Belts squeal in neutral | <ul style="list-style-type: none">• Adjust forward belt guide:<ul style="list-style-type: none">- turn engine off and allow muffler to cool- disconnect spark plug wire and secure from spark plug- remove belt guard- pull down on drive safety control lever- manually bend forward belt guide so there is 1/16 inch or less clearance between belt guide and belt- replace belt guard and spark plug wire |
| Excessive heat build up in transmission/tine area during tilling | <ul style="list-style-type: none">• Remove vegetation by following instructions in Clean Tine Axle Shaft of Normal Care section. FOLLOW ALL SAFETY INSTRUCTIONS• Check transmission fluid and fill if needed |

CRT HANDLEBAR PARTS

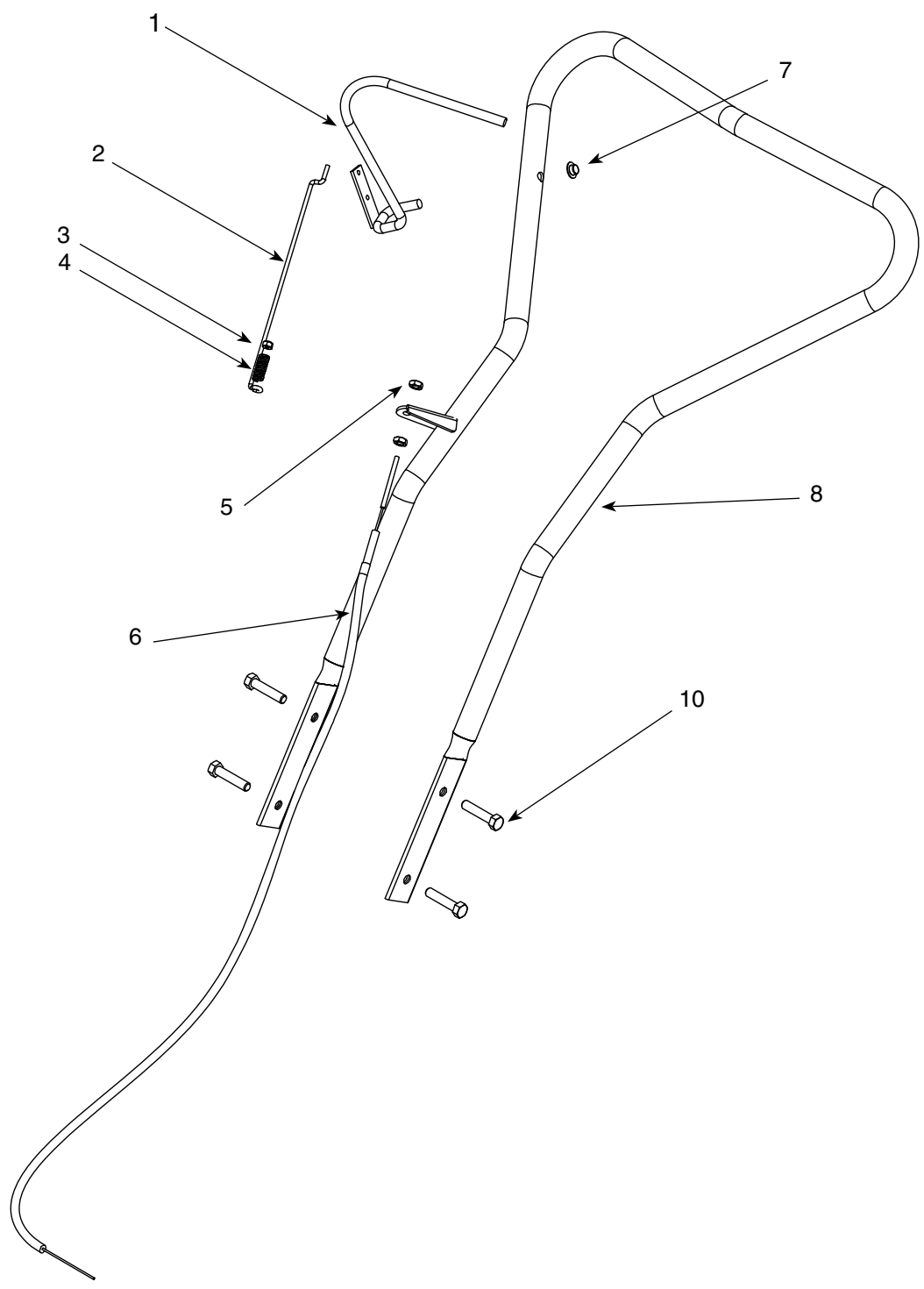

CRT HANDLEBAR PARTS LIST

| REF. NO. | PART # | DESCRIPTION | QTY. |
|----------|--------|-------------------------------------|------|
| 1 | 3262 | DEADMAN, FRONT TINE WELDMENT | 1 |
| 2 | 53613 | LINK, 9-1/2" LONG | 1 |
| 3 | 53606 | NUT, 10-24 HEX ZN | 1 |
| 4 | 53620 | SPRING COMPRESSION FORWARD ARM RT | 1 |
| 5 | 53607 | NUT, 5/16-24 HEX JAM | 2 |
| 6 | 53630 | CABLE, REAR TINE 39" SHEATH | 1 |
| 7 | 3170 | NUT, PUSH 3/8" W/SAFETY WASHER ZN | 1 |
| 8 | 31313 | WELDMENT, HANDLE BAR LOOP REAR TINE | 1 |
| 9 | 2001 | BOLT, 3/8-16 X 1-3/4 HH GR5 ZN | 4 |

CRT MOTOR MOUNT PARTS LIST

| REF. NO. | PART # | DESCRIPTION | QTY. |
|----------|--------|---|------|
| 1 | 810 | BOLT, 5/16-24 X 1 HH GR5 | 2 |
| 2 | 504 | LOCKWASHER, R-SPRING 5/16" | 9 |
| 3 | WF516 | WASHER, FLAT 5/16" STANDARD ZN | 12 |
| 4 | 53649 | GUARD, BELT REAR TINE 12/05 | 1 |
| 5 | 53638 | RIVET, PLASTIC PUSH IN REAR TINE, 12/05 | 1 |
| 6 | 1407 | SPRING FORWARD ARM | 1 |
| 7 | 803 | WASHER, 5/16"ID X 1-1/2"OD FLAT 16 GA. | 2 |
| 8 | 53730 | BOLT, 5/16-18 X 2-1/2 HH GR5 ZN | 4 |
| 9 | 31315 | BELT, DRIVE L4 POWER RATED | 1 |
| 10 | 3178 | PULLEY, SINGLE GROOVE ENGINE | 1 |
| 11 | 802 | BOLT, 5/16-24 X 3/4 HH GR5 ZN | 3 |
| 12 | 53622 | WELDMENT, CABLE PULL PLATE RT, 12/05 | 1 |
| 13 | 742 | SPACER, DRIVE PULLEY .550" | 1 |
| 14a | 31320 | ENGINE, 6.5 HP VIPER HORZ | 1 |
| 14b | 3364 | KEY | 1 |
| 15 | 1501 | BOLT, 5/16-18 X 3/4 SFHH GR5 ZN | 13 |
| 16 | 53618 | CLIP, BELT GUARD TILLERS, 12/05 | 2 |
| 17 | 8655 | BOLT, 5/16-18 X 1-3/4 HH | 4 |
| 18 | 31306 | TAB, BELT GUARD SUPPORT SMALL REARTINE | 1 |
| 19 | 60G5NY | NUT, 5/16-18 NYLOC | 10 |
| 20 | 482508 | BOLT, 1/4-20 X 1-3/4 HHCS GR5 BLK ZN | 1 |
| 21 | 48261B | WASHER, 1/4 BLK ZNC | 6 |
| 22 | 53633 | GUIDE, BELT REAR TINE 12/05 | 1 |
| 23 | 67538 | NUT, 1/4-20 HNYLK ZN | 5 |
| 24 | 48240 | BOLT, 1/4-20 X 1-1/2 HHCS GR5 ZN | 4 |
| 25 | 31302 | PAN, LOWER | 1 |
| 26 | 31301 | PLATE, TRANNY COVER/HOOD MOUNT | 1 |
| 27 | 53413 | DIPSTICK | 1 |
| 28 | 31305 | WELDMENT, ENGINE/HANDLE MOUNT | 1 |
| 29 | 1662 | NUT, 3/8-16 NYLOCK | 4 |
| 30 | WF38 | WASHER, FLAT 3/8 STANDARD ZINC | 4 |
| 31 | 48144B | BOLT, 3/8-16 X 2 HHCS GR5 ZN | 1 |
| 32 | 53596B | YOKE, ZINC PLATED CLEVIS | 1 |
| 33 | 53617 | ARM, FORWARD REAR TINE, 12/05 | 1 |
| 34 | 1416 | PIN CLEVIS | 1 |
| 35 | 1408 | PULLEY, IDLER FORWARD | 1 |
| 36 | 2104 | NUT, 3/8-16 HLKBW ZN | 3 |
| 37 | 53637 | BUSHING, FORWARD ARM REAR TINE, 12/05 | 1 |
| 38 | 739 | BELT GUIDE, REVERSE | 1 |

CRT TINES & HOOD PARTS

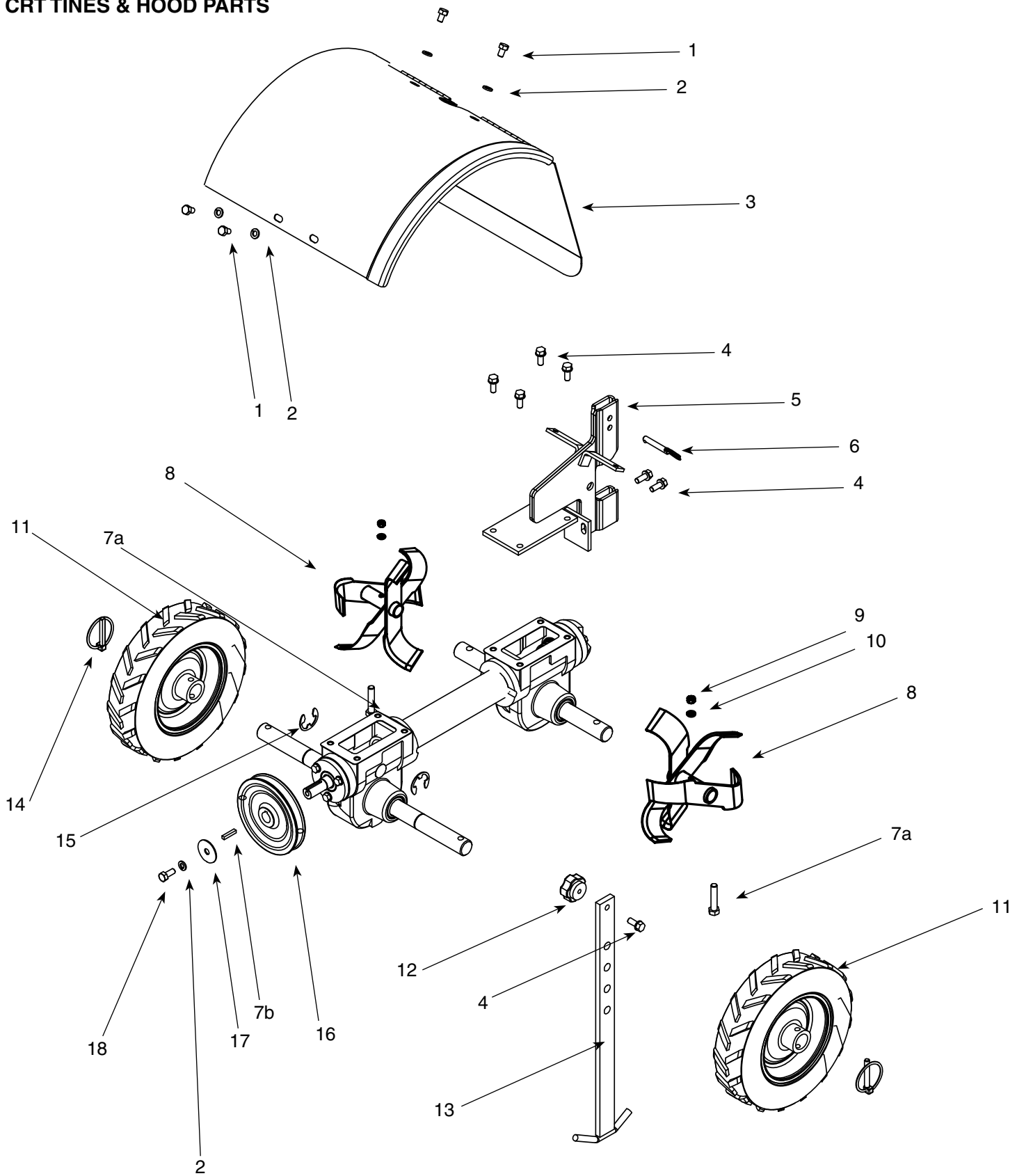

CRT TINES & HOOD PARTS LIST

| REF. NO. | PART # | DESCRIPTION | QTY. |
|----------|----------|--|------|
| 1 | 417 | BOLT, 5/16-18 X 1/2 HH GR5 | 4 |
| 2 | 504 | LOCKWASHER, SPRING 5/16" | 9 |
| 3 | 31311 | HOOD, ASSEMBLY TINE W/HINGE NARROW | 1 |
| 4 | 1501 | BOLT, 5/16-18 X 3/4 HH GR5 ZN | 13 |
| 5 | 53660 | WELDMENT, TAIL MOUNT REAR TINE, 12/05 | 1 |
| 6 | 69170 | DETENT, PIN 5/16 X 2 ZN | 1 |
| 7a | 2001 | BOLT, 3/8-16 X 1-3/4 HH GR5 ZN | 6 |
| 7b | 3364 | KEY | 1 |
| 8 | 1900LCRT | ASSEMBLY, BOLT TOGETHER TINE SET (LEFT) | 1 |
| - | 1900RCRT | ASSEMBLY, BOLT TOGETHER TINE SET (RIGHT) | 1 |
| 9 | 719 | WASHER, 3/8" SPRING LOCK ZINC | 2 |
| 10 | 2104 | NUT, 3/8-16 HLKBW ZN | 3 |
| 11 | 31307 | TIRE, SOLID W/WHEEL DUAL DIRECTION | 2 |
| 12 | 48406 | KNOB, 5/15-18, BLACK FIVE STAR | 1 |
| 13 | 53655 | WELDMENT, DRAG STAKE CRT TILLER, 12/05 | 1 |
| 14 | 1103 | LOCK PIN, 5/16 X 1-3/4 LYNCH PIN 1010 MA | 2 |
| 15 | 1710 | SNAP RING, EXTERNAL RET. | 2 |
| 16 | 31314 | PULLY, TRANSMISSION SMALL REAR TINE | 1 |
| 17 | 803 | WASHER, 5/16"ID X 1-1/2"OD FLAT 16 GA. | 2 |
| 18 | 802 | BOLT, 5/16-24 X 3/4 HH GR5 ZN | 3 |

CRT WHEEL & TILLER SHAFT PARTS & PARTS LIST

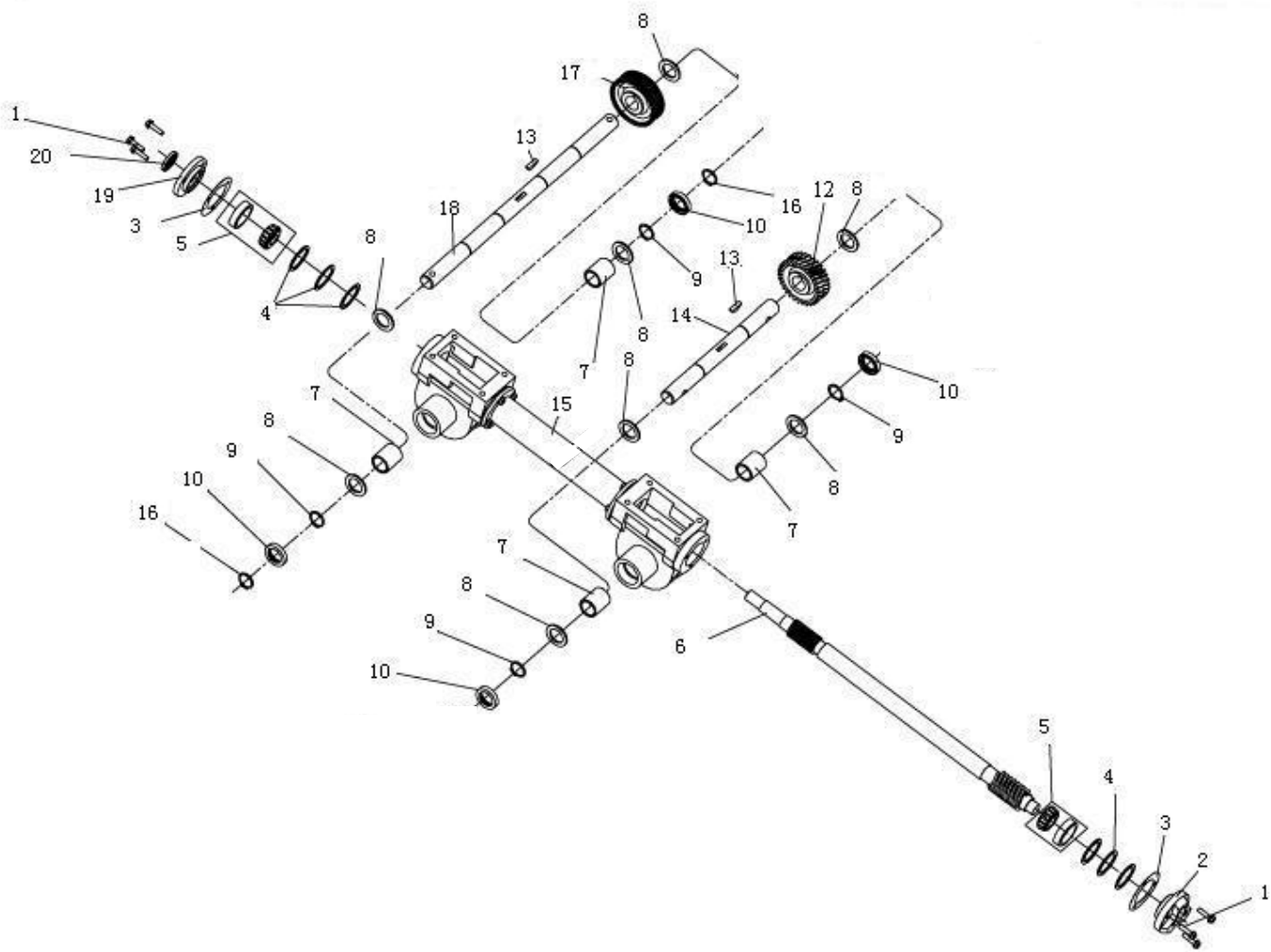

| REF. NO. | PART # | DESCRIPTION | QTY. |
|----------|----------|---|------|
| 1 | 1500P101 | BOLT, M6 X 25MM | 6 |
| 2 | 1500P102 | COVER, REAR TRANSMISSION | 1 |
| 3 | 1500P103 | GASKET, FRONT & REAR TRANSMISSION COVER | 2 |
| 4 | 1500P104 | SHIM, DRIVE SHAFT | 6 |
| 5 | 1500P105 | BEARING, TAPPERED ROLLER | 2 |
| 6 | 1500P606 | SHAFT, DRIVE CRT | 1 |
| 7 | 1500P107 | BUSHING, TINE & WHEEL SHAFT | 4 |
| 8 | 1500P108 | SHIM, TINE & WHEEL SHAFT | 8 |
| 9 | 1500P109 | RING, RETAINER INTERNAL | 4 |
| 10 | 1500P110 | SEAL, GREASE TINE & WHEEL SHAFT | 4 |
| 12 | 1500P512 | GEAR, WORM TINE CRT | 1 |

| REF. NO. | PART # | DESCRIPTION | QTY. |
|----------|----------|---------------------------|------|
| 13 | 1500P113 | KEY, WOODRUFF | 2 |
| 14 | 1500P114 | SHAFT, TINE | 1 |
| 15 | 1500P615 | HOUSING, TRANSMISSION | 1 |
| 16 | 1500P116 | RING, RETAINER EXTERNAL | 2 |
| 17 | 1500P517 | GEAR, WORM WHEEL CRT | 1 |
| 18 | 1500P618 | SHAFT, WHEEL | 1 |
| 19 | 1500P119 | COVER, FRONT TRANSMISSION | 1 |
| 20 | 1500P120 | SEAL, GREASE INPUT | 1 |

Earthquake®

6014V CRT ROTOTILLER

1-YEAR LIMITED WARRANTY

Terms and Conditions

Ardisam, Inc., a manufacturing company, warrants this **EARTHQUAKE® CRT ROTOTILLER** to be free from defects in the material or workmanship for a period of one year from the date of purchase. During the one year warranty of this product, Ardisam will furnish 100% parts and labor to correct any defect caused by faulty material or workmanship. Items subject to normal wear and tear, such as belts, batteries, tines, shear bolts and tires, due to the nature of their function are not covered under this warranty. Any unit used in a commercial application is covered for a period of 90 days after purchase. The engine is covered under a separate warranty issued by the engine manufacturer as stated in the engine manual.

If warranty work needs to be done, contact your place of purchase or Ardisam, Inc. for an authorized service center in your area. Ardisam will make the necessary repairs if a service center is not available. **To obtain warranty service and/or replacement instructions, you must have prior approval from Ardisam before shipping your package to us by calling our customer service department at 800-345-6007 for a return material authorization number (RMA#).** All items must be shipped prepaid. Ardisam, Inc. will at no charge, repair or replace, at their discretion, any defective part which falls under the conditions stated above.

Ardisam retains the right to change models, specifications and price without notice. This product if used as intended, will give you years of trouble free service. We hope you will enjoy the quality of our products for years to come.

For replacement parts, phone 800-345-6007 or go online to www.GetEarthquake.com.

This warranty applies to the original owner with a proof of purchase and is not transferable. It supersedes all other warranties either expressed or implied and all other obligations to liabilities on our part. Ardisam, Inc. does not assume, and does not authorize any other person to assume for us, any liability in connection with the sale of our products.

The warranty applies only to products which have not been subjected to negligent use, misuse, alteration, accident or repairs made by anyone not certified by Ardisam, Inc. This guarantee is void unless the warranty card is properly filled out and received by Ardisam, Inc., within 30 days of purchase or go to www.GetEarthquake.com for online registration.



EARTHQUAKE
A Division of Ardisam, Inc.
1360 First Avenue; P.O. Box 666
Cumberland, Wisconsin 54829
800-345-6007 · Fax (715) 822-4180
E-mail: info@ardisam.com



Visit www.ardisam.com and discover more innovations that will benefit you throughout the year.

Earthquake[®]

Earthquake, Division of Ardisam, Inc.
1360 First Avenue; P.O. Box 666
Cumberland, Wisconsin 54829
800-345-6007 · Fax (715) 822-2223
E-mail: info@ardisam.com



GetEarthquake.com