



Instruction Manual

To ensure maximum performance and safety, please follow this manual. Please retain the manual for future reference after installation

Model: BlackAir 10, 12 & 15

OWNERS MANUAL

Model: BlackAir 10, 12 & 15

Congratulations on purchasing your VIBE Blackair subwoofer. Please read this manual in order to fully understand how to get the best results from your subwoofer and ensure that all advice on how to look after the Subwoofer is followed. Thank you for buying VIBE. We hope you enjoy listening to your product as much as we enjoyed creating it.

VIBE R&D Division

Features

- Surround - VIBE's unique specially formed HighRoll™ rubber edge allows increased cone excursion whilst the narrow design retains stronger lateral control of the cone.
- Tinsel wires - Heavy gauge tinsel wires run more freely to the voice coil via a newly formed flange. The heavier gauge maximises full power delivery from your chosen speaker wire directly to the voice coil.
- Cone - Specially moulded absorbing PP cone – incorporates specially formed plastic shroud to firmly attach voice coil to the cone.
- Magnet - Magnet increased in quality, power and size. With additional increase in the magnetic gap allowing bigger performance and better voice coil cooling.
- Rubber boot - Protects the oversized magnet and integrates the basket with magnet in a more streamline fashion for reverse mounting styling.
- T-Yoke - Extended bumped t-yoke for higher cone travel with large vented pole to greatly aid voice coil cooling.
- Dual Voice coil - Fast cooling vented aluminium formers using multilayered dual voice coils with increased 3rd generation windings for bigger true sub bass.
- Spider - Dual flat progressive, long life conex spiders used to keep cone movement 100% lateral, even when under the highest pressures.
- Basket - Specially designed for absolute rigidity, the VIBE angular torsion™ basket has five vented powerful arms that cradle the cone and allow the coil to breath cool air.
- Terminals - Improved terminal for better stronger and bigger cable feeds.
- Alloy gasket - Alloy gasket executes the outer edge of the subwoofer in true VIBE style, with a carefully placed alloy CNC VIBE badge on the cone for final sign off.

Specification

Specifications*	BlackAir 10	BlackAir 12	BlackAir 15
Speaker Size	10" (274mm)	12" (323mm)	15" (392mm)
RMS Power	450w	550w	650w
Peak Power	1300w	1600w	2000w
Sensitivity	87dB	89dB	90dB
Frequency Response	30 - 1500Hz	25 - 1200Hz	20 - 1000Hz
Impedance	Dual 2 ohm	Dual 2 ohm	Dual 2 ohm
Mounting Depth	137mm	155mm	178mm
Mounting Diameter	235mm	285mm	350mm
Displacement	0.13Cu.Ft.	0.21Cu.Ft.	0.35Cu.Ft.
Recommended Amp	SLICK A7 BlackBox BASS 2 /4	SLICK A7 BlackBox BASS 2 /4	SLICK A7 BlackBox BASS 2 /4

Run in procedure

VIBE recommends that you follow the run in procedure for the subwoofer detailed below.

When your Subwoofer is used for the first time, like most brand new items it is naturally very stiff and rigid. It will take time for the moving parts of this Subwoofer to loosen up before the Subwoofer will be ready to deliver its full potential.

For the first 30 hours it is recommended that you play the Subwoofer initially at low to medium volumes, gradually increasing the volume level as time progresses.

As a guide, if you listen to your Subwoofer for 1 hour every day it will take a month for the subwoofer to run in properly.

You will notice a big change in the sound of the Subwoofer over this period. As the spider and surround begin to run in the sound will get deeper and harder, also the output of the Subwoofer will increase as the suspension loosens up.

The Subwoofer is like your car's engine, it needs a few thousand miles before you can drive it to its full potential. Driving it into the redline from the first day will mean engine damage is certain and will not be covered by warranty.

Failure to follow this simple procedure is the most common reason for a Subwoofer to fail after a very short period of time.

Wiring options

The Blackair subwoofer has a dual 2 ohm voice coil. Below are a few different wiring examples, please check with your amplifier manufacturer as to which wiring method is most suitable.

single woofer configuration

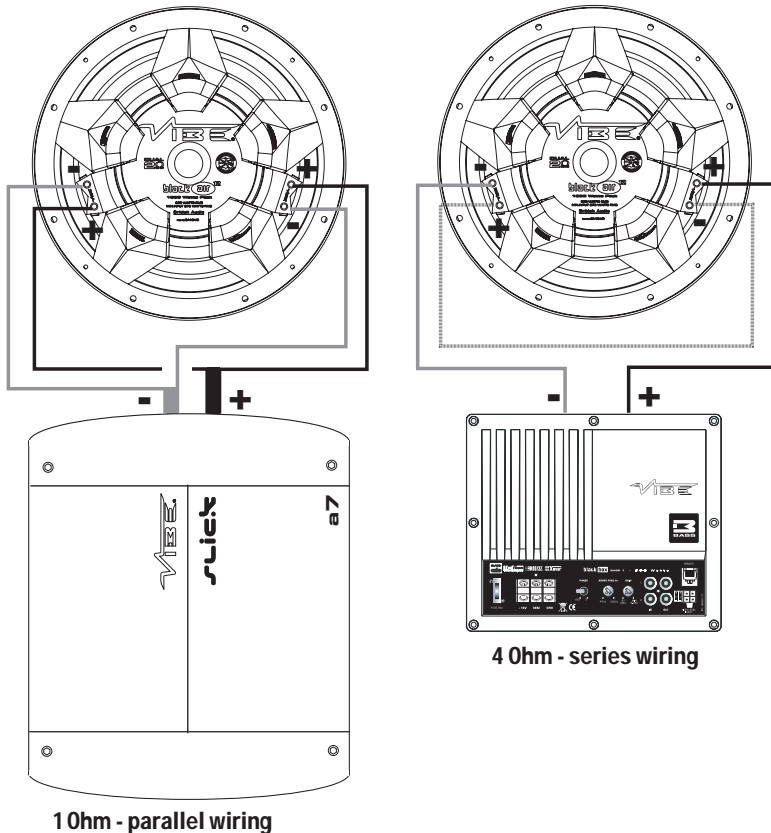

Twin woofer configuration

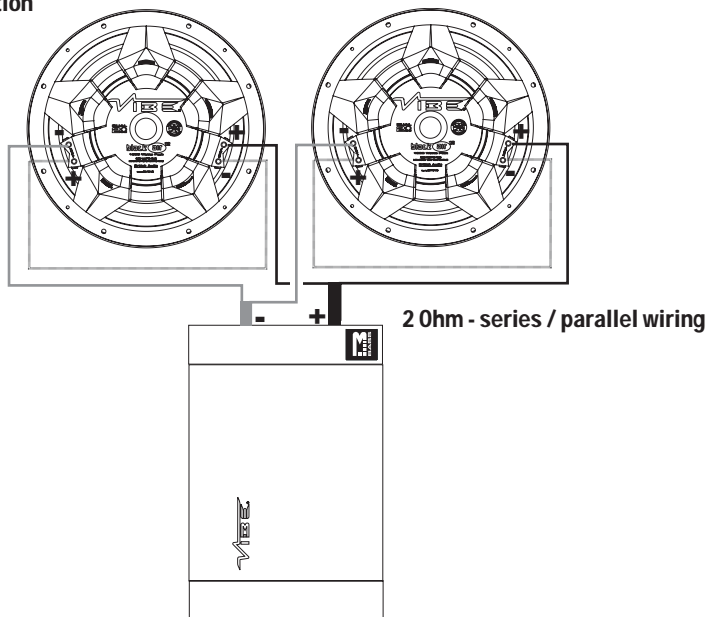

Installation

The Blackair subwoofer can be installed in a variety of different ways, the most suitable will depend upon your application.

Free-air installation

The VIBE Blackair Subwoofer can be mounted free-air, but this does not mean that the woofer can work without any form of enclosure. What it does mean is that the enclosure can be very large and therefore the subwoofer can utilise the vehicles boot as an enclosure.

The Subwoofer needs to be mounted to a rigid panel as excess vibration will result in poor sound quality. The panel or baffle, should also seal the output from the front of the Subwoofer from the output from the rear otherwise poor sound quality, known as phase error, will occur. This simply means that the output from the rear of the woofer will cancel out the output from the front resulting in a loss of bass.

As the enclosure in free-air applications is so large it is worth noting that the power handling of the Subwoofer is reduced to half that of the same woofer in a measured enclosure. Please take this into account when choosing your amplifier.

The sound quality of a free-air mounted Subwoofer will not match that of the same subwoofer mounted in a measured enclosure. However in applications where building a traditional enclosure is impossible, free-air mounting will add increased bass response to your system.

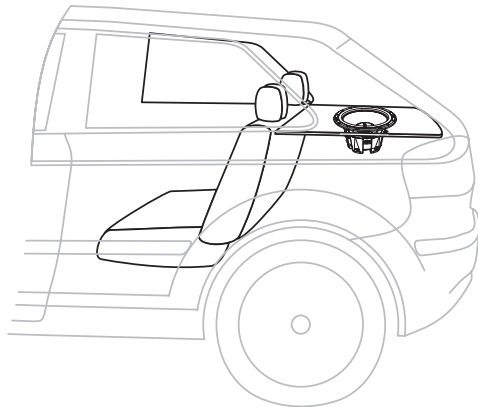

Sealed enclosure installation

The most basic and simple of all speaker enclosures is the sealed enclosure otherwise referred to as an acoustic suspension design. They are called acoustic suspension enclosures because the air inside the box acts like a brake to control the woofer. The sealed enclosure is the easiest design to build and tune, as long as you work within the minimum and maximum recommended volumes you cannot get it wrong. The smaller enclosures produce a tighter punchy bass, the larger enclosures produce a deeper bass. Sealed enclosures offer high power handling, tight response and smooth low end roll off and cone motion is better controlled at all frequencies because of the constant pressure on the back of the woofer. Sealed enclosures are ideally suited to rock, jazz and live music.

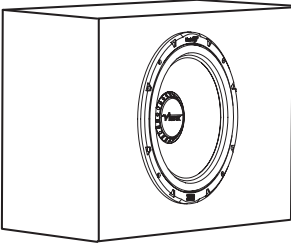

PRODUCT	TIGHT BASS	DEEP BASS
Black air 10	1.0 cu.ft	1.5 cu.ft
Black air 12	1.5 cu.ft	2.0 cu.ft
Black air 15	1.75 cu.ft	2.5 cu.ft

For twin enclosures simply double the volume. E.G. 2 x Blackair 10 in deep bass enclosure will be 3.00cuft

Ported enclosure installation

A ported or vented enclosure is not much more complex than a sealed design. It consists of a box with a hole in it. The vented enclosure has to be correctly designed in order to function correctly. The vent in the enclosure interacts with the air in the cabinet and the woofer to increase output and reduce cone excursion at and around the tuning frequency. At the tuning frequency of the enclosure almost all of the bass is being produced by the vent, not the woofer. It is more difficult to achieve good performance as the enclosure volume and port volume are critical but the results are worth it as the ported box is up to 3 times as loud as the same woofer in a sealed box. It is also possible with the correct tuning to add a "bump" in the response of the enclosure to boost bass at a preferred frequency. Vented enclosures are best suited to dance, R&B, electronically produced music and high SPL applications.

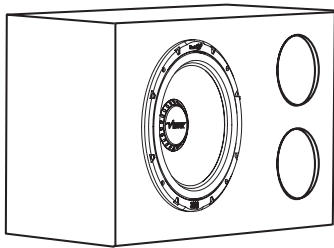

PRODUCT	VOLUME	PORT
Black air 10	1.0 cu.ft	1 x 4" port, 10" length
Black air 12	1.5 cu.ft	2 x 3" ports, 6" length
Black air 15	2.0cuft	2 x 3" ports, 10" length

For twin enclosures simply double both the volume and the porting. E.G. for 2 x Blackair 10 the enclosure will be 2cuft with 2 x 4" ports
Many other ported options exist, please contact VIBE for more information

Enclosure construction

Use at least 3/4 inch MDF (medium density fibreboard) or Birch ply to construct your enclosure and at least 1 inch is recommended for the baffle. It is recommended that the panels are glued, screwed and braced with sections of the same material you have used to build the enclosure from. The BlackAir woofer is capable of producing internal pressures that can literally blow apart badly made enclosures, so great care needs to be taken with the construction and bracing of your enclosure. It is also worth sealing the joints with a silicone sealer once the glue has dried to make a perfect airtight seal.

NOTE- Do not screw the Subwoofer into the enclosure within 24 hours of applying silicone sealer to the joints. The gases given off as the silicone cures can perish the surround of the Subwoofer causing a non warranty failure.

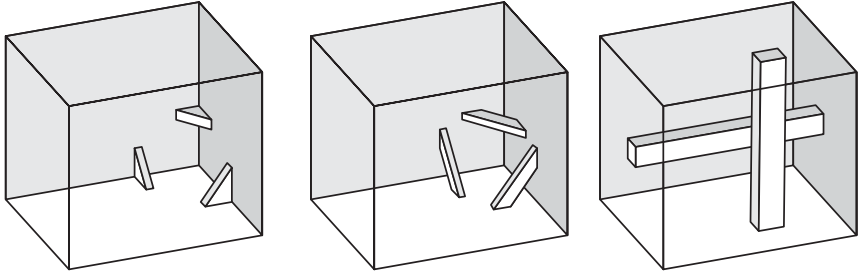

Enclosure Volume

To work out the volume required for your enclosure please refer to recommended enclosure volumes specified for your Subwoofer. These are listed in cubic feet. To convert cubic feet to litres multiply the cubic feet by 28.3. If you use this formula calculating your enclosure size will be easy .1 cubic foot is expressed as 12" x 12" x 12" = 1728 cubic inches

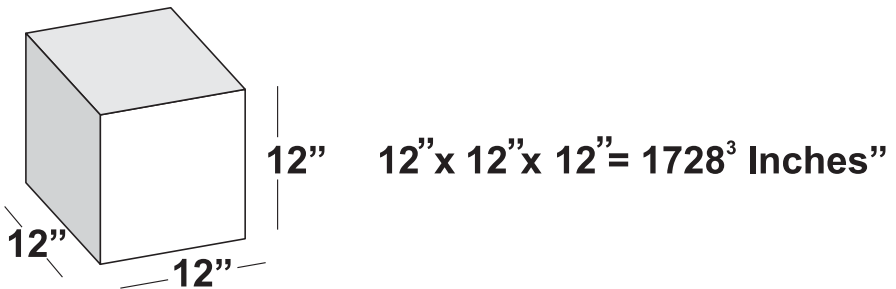

If we require a volume of 2.5cuft then we multiply this by 1728 $2.5 \times 1728 = 4320$ cubic inches.

We now take 2 known enclosure dimensions that we will use, e.g height and width and divide this figure by them which will give us the depth, for example our height is 15", our width is 20".

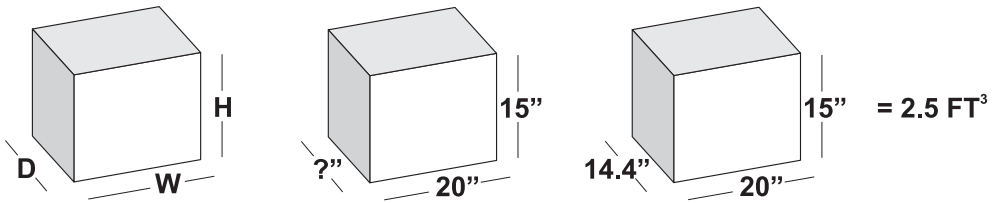

So our depth is 14.4" for this enclosure.

Note : this formula is for the INTERNAL dimensions, please add the thickness of the material used to construct the enclosure to the formula to give you the outside dimensions.

So assuming we are using 1 inch material we need to add 2 thicknesses to each internal dimension to allow for material top and bottom, so the external dimensions for this enclosure would be 17 x 22 x 16.4 inches.

The displacement of the woofer and the displacement of the port must also be added to the required volume before you calculate the required sizes needed to build your enclosure.

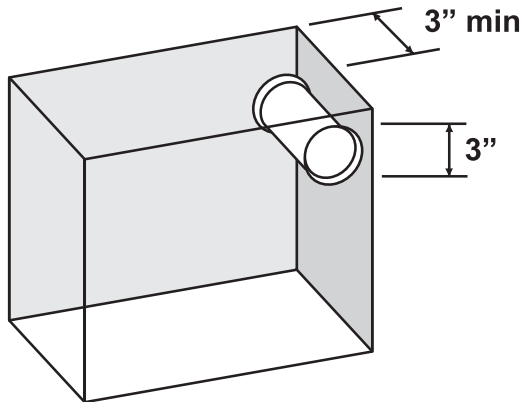

NOTE- When using a port you must leave a gap at least equal to the shortest measurement of the port between the rear of the enclosure and the port.

Limited Warranty

All VIBE products carry a full twelve months warranty period, valid from the date of the original receipt and proof of purchase. In order to validate this warranty, the warranty card should be returned to VIBE within seven days of the original purchase date. The original receipt and packaging are should also be retained for this twelve month period.

If at any stage during the warranty period you have a problem with the product then it should be returned to the point of purchase, in its original packaging, complete with no items missing.

If the store is unable to fix the product it may have to be returned to VIBE This process takes around 7 working days and no costs will be occurred.

A full description of VIBE's warranty information can be found on our website:

www.vibeaudio.co.uk/warranty

A written version can also be obtained from
VIBE warranty Dept.

What is not covered.

- Damage to product due to improper installation
- Subsequent damage to other components
- Damage caused by exposure to moisture, excessive heat, chemical cleaners and/or UV radiation
- Damage through negligence, misuse, accident or abuse, repeated returns for the same fault may be considered abuse
- Any cost or expense related to the cost of removal or re-installation of the product
- Damage caused by amplifier clipping or distortion
- Items repaired or modified by any unauthorized repair facility
- Return shipping on non defective items
- Products returned without a returns authorization number
- Damage to product due to the use of sealant

International warranty

Contact your international Vibe audio dealer or distributor concerning specific procedures for your country's warranty policies

Warning

Vibe subwoofers are capable of sound pressure levels that can cause permanent damage to your hearing and those around you, please use common sense when listening to your car audio system and Practice safe sound.

Copyright

All content included in this manual such as text, graphics, logos, icons, images and data, are the property of VIBE Technologies Limited (herein referred to as "VIBE", "us" or "we") and its affiliate or their content and technology providers, and are protected by United Kingdom and International copyright laws. All rights reserved.

VIBE Turbo Port, Vibe TurboVent, Pressure Board, Super Driver, VIBE Pulse, VIBE Power, VIBE Digital, VIBE MAG Plugs, Ferrite Loaded, VIBE Solid Core, VIBE OCC, VIBE FLAT, BlackAir, BlackBox, Space, MonoBox, SA-K, SR, QB69, ICC, Bass Enhance, Bass Enhance+, QBass, SpeedBass, PowerBass and all stylised representations of product names, or the abbreviations of product names, as logos are all trademarks of VIBE. Graphics and logos are trademarks or trade dress of VIBE Technologies Ltd or its subsidiaries.

VIBE's trademarks and trade dress may not be used in connection with any product or service that is not VIBE's, in any manner that is likely to cause confusion among customers or in any manner that disparages or discredits VIBE. All other trademarks not owned by VIBE or its subsidiaries that appear in this manual are the property of their respective owners, who may or may not be affiliated with, connected to, or sponsored by VIBE or its subsidiaries.

TO THE FULLEST EXTENT PERMITTED AT LAW, VIBE IS PROVIDING THIS MANUAL AND ITS CONTENT ON AN "AS IS" BASIS AND MAKES NO (AND EXPRESSLY DISCLAIMS ALL) REPRESENTATIONS OR WARRANTIES OF ANY KIND, EXPRESS OR IMPLIED, WITH RESPECT TO THIS MANUAL OR THE INFORMATION, CONTENT, MATERIALS OR PRODUCTS INCLUDED IN THIS MANUAL INCLUDING, WITHOUT LIMITATION, WARRANTIES OF MERCHANTABILITY AND FITNESS FOR A PARTICULAR PURPOSE.

IN ADDITION, VIBE DOES NOT REPRESENT OR WARRANT THAT THE INFORMATION CONTAINED IN THIS MANUAL IS COMPLETE OR CURRENT, AND THAT ALL SPECIFICATIONS AND INFORMATION CONTAINED WITHIN THIS MANUAL ARE SUBJECT TO CHANGE WITHOUT NOTICE. VIBE RECOMMEND CAUTION WHEN LISTENING TO MUSIC REPRODUCED THROUGH VIBE EQUIPMENT. VIBE EQUIPMENT IS CAPABLE OF PRODUCING SOUND AND SOUND PRESSURE LEVELS THAT CAN PERMANENTLY DAMAGE HEARING OF YOU AND THAT OF OTHERS. FOR SAFE AND ENJOYABLE LISTENING, THE SOUND SHOULD BE CLEAR WITHOUT DISTORTION AT A COMFORTABLE VOLUME.

BY USING ANY VIBE EQUIPMENT, YOU AGREE TO TAKE FULL RESPONSIBILITY FOR YOUR OWN SAFETY AND THE SAFETY OF OTHERS WHEN LISTENING TO MUSIC AT HIGH VOLUMES THROUGH EQUIPMENT YOU HAVE PURCHASED. USE OF ANY VIBE EQUIPMENT CONSTITUTES AGREEMENT TO THIS DISCLAIMER.

Except as specifically stated in this manual, to the fullest extent permitted at law, neither VIBE nor any of its affiliates, directors, employees or other representatives will be liable for damages arising out of or in connection with the use of this manual or the information, content, materials or products included.

This is a comprehensive limitation of liability that applies to all damages of any kind, including (without limitation) compensatory, direct, indirect or consequential damages, loss of data, income or profit, loss of or damage to property and claims of third parties. For the avoidance of doubt, VIBE does not limit its liability for death or personal injury to the extent only that it arises as a result of negligence of VIBE, its affiliates, directors, employees or other representatives.

Parameters for BlackAir Subwoofers

	BlackAir 10	BlackAir 12	BlackAir 15
RMS power	450	550	650
Peak power	1300	1600	2000
Min. Input wattage	225	275	325
Diameter in inches	10"	12"	15"
Z- Nominal Impedance in Ohms	Dual 2 Ohm	Dual 2 Ohm	Dual 2 Ohm
Revc = DC voice coil resistance in Ohms	3.6	3.6	3.6
Fo = Free air resonance frequency in Hz	40.959	34.995	32.371
Sd = Piston area in square meters	34.600	53.000	85.000
Vas = Equivalent acoustic volume in cubic litres	15.386	46.311	119.250
Cms = Mechanical suspension compliance	90.152	116.102	116.234
Mmd = Diaphragm mass in grams	117.997	144.112	193.713
Mms = Mechanical mass of cone and free air load in grams	121.677	151.128	207.962
BL = The magnetic strength of the motor structure	15.111	15.37	17.796
Qms = Mechanical Q factor of driver	1.171	1.952	1.992
Qes = Electrical Q factor of driver	0.578	0.550	0.501
Qts = the system's Q at resonance (Fc)	0.437	0.429	0.417
n0 = The reference efficiency of the system in %	0.284	0.447	0.800
SPL = Speaker's SPL 1 watt at 1meter in dB:	86.55	88.521	90.122
Voice Coil Diameter in inches	2	2	2.5
Mounting Depth in mm	128	141	168
Mounting Diameter in mm	240	285	355
Magnet weight in oz	40	60	75



In order to protect your purchase and aid your warranty please fill in the following form and keep it safe for your future reference:

Model Number:

Serial Number:

Purchased From:

Date of Purchase:

KEEP IT SAFE
Staple your receipt here:

**FLATBASS™ 13 SPK Bass speaker cable**

There are many powerful bass amplifiers on today's market – the ever increasing power is putting huge strains on speaker wire – VIBE present a new breed of speaker cable specially developed for BASS applications – the VIBE FLATBASS speaker cable offers SolidCore™ that can handle and sustain considerably more power than conventional speaker cable.

Model: FlatBass 13 SPK – 13 gauge SolidCore™ flat BASS speaker cable

**VIBE 140 amp circuit breaker**

Big systems require big protection – The VIBE circuit breaker is rated at a massive 140 amps and offers critical protection to your system – if the system over powers or short circuits the breaker will cut in and save your equipment. No need to replace expensive fuses, system is reset via a simple switch – also offers safe and instant system shutdown.

Model: CB140 – 140 amp circuit breaker

**FLAT Y 2M / FLAT Y 2F RCA Y leads**

Our professional quality full range OFC Yinterconnect guarantees a pure and strong signal. With a flat design and ferrite loaded gold plated plugs interference is greatly reduced. The FLAT-Y Interconnect is available in 1 male – 2 female FLAT Y 2F and 2 male – 1 female FLAT Y 2M configurations.

Model: FLAT Y 2f – 1 pair RCA Y lead 1male to 2 female
Model: FLAT Y 2m – 1 pair RCA Y lead 2male to 1female

**VIBE BC10 level controller**

The VIBE BC10 gain level controller is a perfect addition to any subwoofer system, the BC10 allows the level of the amplifier to be controlled from the driver's seat giving the user easy adjustment of gain level. Particularly useful for adjusting the gain level for amplifiers controlling subwoofers. The BC10 controller is RCA input and output making it compatible with any system allowing gain level adjustment of any amplifier it is connected to. It can also be used with full range amplifiers.

Model: BC10 – RCA Gain level control

**Slick level remote**

A new addition to the Slick range of amplifiers is the Slick level control which allows level adjustment of the amplifier from the front of the car - Simply plug the supplied cable into the Slick remote level port on the end panel of the amplifier and remotes gain control is yours, it is that easy.

Model: SLR1 – optional remote for use with all Slick amplifiers

**VIBE PortPlug™**

The VIBE PortPlug allows easy tuning of the VIBE CBR bass enclosures. The PortPlug™ is used to tightly seal the VIBE TurboPort™ in the enclosure to either create a sealed enclosure for better transient response or in the case of a multi ported enclosure re-tune the enclosure using only 1 PortPlug™

Model: PP25 – PortPlug™ for 2.5" TurboPort™
Model: PP30 – PortPlug™ for 3" TurboPort™

**VIBE official Merchandise**

MPS – VIBE polo shirt with embroidered VIBE logo on front and rear
MTS – VIBE T-shirt with small VIBE printed logo on front.
MCD – VIBE CD, containing exclusive VIBE bass tracks as featured on the Bass Tunnel and VIBE Dredd.
MCC – VIBE CD case, metallic silver CD case with VIBE logo.
VFL – VIBE fleece with embroidered logo on the front and large on back.
VTD – VIBE tax disc holder, stylish silver tax disc holder featuring VIBE logo.

**VIBE SD4/5 subwoofer defender grill**

The new VIBE subwoofer defender not only provides protection for your sub but also adds style with its metallic badge and black rubberised steel construction allow it to integrate perfectly with the VIBE EVO enclosures

Model: SD4 – sub grill fits both 10" and 12" subwoofers
Model: SD5 – sub grill fits 15" subwoofers

**VIBE GB41 banana plug**

The VIBE GB41 banana plugs are the easy and convenient way to quickly remove your bass enclosure without having to constantly re-tune your speaker cable into the box terminal, simply attach the speaker cable to the VIBE GB41 banana plug and you have a reliable quick release solution. Designed for optimum use with the IP-2 and GP-4 terminal, our professional gold plated 4mm banana plugs are polarity marked and feature rubber shrouds.

Model: GB41 – Gold Banana plug

**VIBE DB6 non fused distribution block**

The VIBE DB6 non fused distribution block is a professional non fused distribution block which gives easy connection for up to 5 amplifiers. The VIBE DB6 has 2 x 4AWG input and 4 x 8AWG outputs which can be used for power distribution or ground distribution giving a common grounding point for all system components eliminating the risk of ground loop interference.

Model: DB6 non fused distribution block

**VIBE FD4 fused distribution block**

The VIBE FD4 fused distribution block is a professional AGU fused distribution block which gives easy connection for up to 4 amplifiers. The VIBE FD4 has 1 x 4AWG input and 4 x 8AWG outputs each individually fused up to a maximum of 80 amps (AGU fuses available separately)

Model: FD4 – 4 way AGU fused distribution block, 1 x 4 gauge input, 4 x 8 gauge outputs

**VIBE CT0 / CT4 compression fit ring terminal**

The VIBE CT range of gold plated ring terminals are professional compression fit designed for maximum conductivity when connecting power cable to the vehicle battery. The VIBE RT compression fit terminals are the best way to connect heavy gauge power cable to the vehicles battery.

Model: CT0 – 0 gauge compression fit ring terminal
Model: CT4 – 4 gauge compression fit ring terminal

**VIBE RT4 / RT8 crimp on ring terminal**

The professional range of VIBE RT gold plated ring terminals for connecting power cable to the vehicle battery. Packed in pairs and include red and black rubber over boots with an easy crimp design.

Model: RT8 – 1 pair of 8 gauge crimp on ring terminals with PVC overboots
Model: RT4 – 1 pair of 4 gauge crimp on ring terminals with PVC overboots

**VIBE AGU30, AGU60, AGU80 fuses**

The VIBE AGU fuse series are the perfect companion to the VIBE FD4 fused distribution block and the Active and stereo system wiring kits.

Model: AGU30 – 1 pair 30 amp AGU fuses to fit all AGU fuse holders
Model: AGU60 – 1 pair 60 amp AGU fuses to fit all AGU fuse holders
Model: AGU80 – 1 pair 80 AGU fuses to fit all AGU fuse holders

All Accessories are available direct, for next day delivery call 0870 765 8423 or visit www.vibeshop.co.uk (UK ONLY)

For more product info see www.vibeaudio.co.uk



The CriticalLink™ range of FLAT series cabling from VIBE

The VIBE CriticalLink range of cabling has been developed to achieve the critical link between source (headunit), amplifier and speakers - VIBE audio equipment is high quality, using anything less than the VIBE CriticalLink™ range of cables will severely compromise your equipment and will not allow it to perform to its maximum potential.

NOTE: Your audio equipment will only ever be as good as the cables you use to connect it. The link between your audio equipment is critical for a bigger cleaner sound.

VIBE cabling and interconnects can enhance your system power and sound quality by more than 20% over other brand cable.

All Accessories are available direct, for next day delivery call 0870 765 8423 or visit www.vibeshop.co.uk [UK ONLY]
For more product info see www.vibeaudio.co.uk



BASS SYSTEM KIT

The VIBE 3000watt BASS KIT is specifically designed to gain maximum output from high power Bass systems. Featuring the best BASS specific cables from the VIBE CriticalLink™ Range.

Contents of this Kit:
 FLATLINES™ 4AWG PWR Power and Ground cable
 VIBE FLATSTERED™ RCA SolidCore™ Interconnect
 FLATBASS™ 13 SPK Bass speaker cable
 FLATLINES™ remote 18
 VIBE 140 amp circuit breaker

All cable is terminated with crimped terminal rings in place and accessory fitting kit

COMPATIBILITY

This kit is compatible with the majority of amplifiers on the market - VIBE recommends this kit for all VIBE BASS monoblock amplifiers new, current and old models.

Model: Bass Kit - Bass specific amplifier wiring kit



STEREO SYSTEM KIT

The VIBE 1500 watt STEREO KIT is specifically designed to gain maximum output from high power full range systems. Combining the best full range cables from the VIBE CriticalLink™ range.

Contents of this Kit:
 FLATLINES™ 8AWG PWR Power and Ground cable
 VIBE FLATSTERED™ RCA - OFC high definition full range interconnect
 FLATLINES™ remote 18
 FLATSTERED™ speaker cable
 AGU Fuse Holder

All cable is terminated with crimped terminal rings in place and accessory fitting kit

COMPATIBILITY

This kit is compatible with the majority of amplifiers on the market - VIBE recommends this kit for all VIBE full range STEREO amplifiers new, current and old models. FLATLINES™ B PWR Power

Model: Stereo Kit - full range stereo amplifier wiring kit



ACTIVE SYSTEM KIT

The VIBE 1500watt ACTIVE BASS KIT is specifically designed to gain maximum output from high power Active Bass systems (Bass Boxes). Featuring BASS specific components from the VIBE CriticalLink™ range.

Contents of this Kit:
 FLATLINES™ 8AWG PWR Power and Ground cable
 VIBE FLATSTERED™ RCA SolidCore™ Interconnect
 FLATLINES™ remote 18
 AGU Fuse Holder
 FastPlug™

COMPATIBILITY

This kit is compatible with the majority of amplifiers on the market - VIBE recommends this kit for all VIBE active bass enclosures new, current and old models.

Model: Active Kit - Bass specific active enclosure wiring kit



PC 15
 1.5 farad
 power capacitor

The VIBE 1.5 farad power capacitor is a must for any high performance audio system. VIBE's 1.5 farad power capacitor bridges the gap between the vehicles battery and the amplifiers ensuring rapid smooth current flow resulting in louder tighter bass and clean crisp midrange and treble. The built in digital voltage display constantly and accurately displays the systems DC voltage. An all new VIBE power distribution block is built into the top of the capacitor to allow easy wiring into the system and will also allow 3 amplifiers to be wired directly to the capacitor for maximum current flow to the amplifiers.

Model: PC15



The DeltaBox line driver is the ideal solution for those looking to install multiple amplifiers from a single RCA source. Most people use RCA "Y" splitters for this task unaware of the signal degradation caused. The DeltaBox not only divides the signal but also isolates and boosts the signal up to a maximum of 9 volts independently for each of the 3 output channels giving much cleaner sound and excellent signal to noise ratio. For SPL competition the DeltaBox is an essential tool as each of the outputs can be split 4 times giving control of 12 amplifiers from a single gain enabling precise adjustment of the system without having to reset every amplifier individually. Additionally, if your headunit has a weak preout or you wish to run multiple amps but only have one output the DeltaBox™ is your ideal solution. Model: DELTABOX

The VIBE FastPlug™ (pat. pending), is a product long overdue. Designed and developed by VIBE Engineers the plug offers safe, fast removal of your active bass enclosure (bass box) or amplifier. You may wish to remove your system for security reasons, or for the full use of your boot space, whatever the reason the VIBE FastPlug makes it easy and safe.

The plug is a heavy duty connector that connects positive, negative and remote wires. It is made up of 2 parts - one end to connect to your equipment and the other to your power source - made from high quality ABS plastic the device is tough and hard wearing. Model: FASTPLUG



FLATLINES™ Power and Ground Cable

VIBE FlatLines™ power cable has been developed to maximise voltage transfer from battery to amplifier - The cable has 2 main lines running side by side which are made up of fine copper strands - This design makes the cable flat allowing us to make very slim heavy duty power cable which is highly flexible easing installation.

Available in: system kits, by the roll or by the metre
 Model: FLATLINES B PWR - 8gauge red power cable Model: FLATLINES B GND - 8gauge black power cable
 Model: FLATLINES 4 PWR - 4gauge red power cable Model: FLATLINES 4 PWR - 4gauge red power cable
 Model: FLATLINES 0 PWR - 0gauge red power cable Model: FLATLINES 0 GND - 0gauge black power cable



FLATSTERED™ High Definition full range Interconnect

The VIBE FLATSTERED RCA is an OFC high definition full range interconnect - delivering the fullest signal possible from source to amplifier - the cable make up has been developed to run flat with left and right cables running parallel both with individual screening but sharing an outer FLAT jacket easing installations.

Available in:
 Model: FlatStereo RCA 1m - 1 metre full range interconnect
 Model: FlatStereo RCA 5m - 5 metre full range interconnect



FLATBASS™ - SolidCore™ Bass interconnect

The VIBE FLATBASS™ interconnect has been specifically developed for use in BASS SYSTEMS - the cable make up has a unique super FLAT™ design easing installation - Its trick ingredient is oversized SolidCore™ OFC signal wires - allowing a heavier voltage to be passed down the cable. This is the central wire that carries the main signal from source to amplifier.

Available in:
 Model: FlatBass RCA 1m - 1 metre BASS interconnect
 Model: FlatBass RCA 5m - 5 metre BASS interconnect



FLATFLEX™ High Definition speaker cable

The delivery of power and signal to the speaker is the final CriticalLink™ in any audio system - VIBES FlatFlex OFC high definition speaker cable is produced from super fine OFC copper strands collectively picking up all the detail in your music - the multi strands are aligned in a row making the cable super FLAT™ which can be run invisibly under carpets.

Available in:
 Model: FlatFlex 16 SPK - 16 gauge High definition flat flexible speaker cable
 Model: FlatFlex 12 SPK - 12 gauge High definition flat flexible speaker cable