

# atmoCRAFT



VK 654/9 - 1654/9



For the heating engineer

Installation and maintenance instructions  
**atmoCRAFT**

Gas heating boiler

VK 654/9 - 1654/9

## Contents

<b>1</b>	<b>Notes on the documentation</b> .....	<b>3</b>	6.2	Checking the gas setting .....	26
1.1	Storage of the documents .....	3	6.2.1	Default setting .....	26
1.2	Symbols used .....	3	6.2.2	Checking the connection pressure (gas flow pressure) .....	26
<b>2</b>	<b>Description of the appliance</b> .....	<b>3</b>	6.2.3	Setting the gas in accordance with the nozzle pressure method .....	27
2.1	Identification plate .....	3	6.2.4	Gas setting tables .....	28
2.2	CE label .....	4	6.2.5	Function check .....	29
2.3	Intended use .....	4	6.2.6	Changeover from natural gas to liquid gas P..	29
2.4	Structure of atmoCRAFT .....	4	6.2.7	Changeover from liquid gas P to natural gas..	30
2.5	Scope of delivery and accessories .....	4	6.2.8	Checking the exhaust gas installation .....	30
2.6	Type overview .....	5	6.3	Training the operator .....	30
2.7	Functional and operating elements .....	6	6.4	Vaillant warranty .....	31
<b>3</b>	<b>Safety instructions and regulations</b> .....	<b>7</b>	<b>7</b>	<b>Adapting the appliance to the heating system</b> .....	<b>31</b>
3.1	Safety instructions .....	7	7.1	Selection and setting the parameters .....	31
3.2	General requirements .....	8	7.2	Overview of the adjustable installation parameters .....	32
3.2.1	Preliminary remarks for room sealed appliances .....	8	<b>8</b>	<b>Inspection and maintenance</b> .....	<b>33</b>
3.2.2	Related documents .....	8	8.1	Notes for maintenance .....	33
<b>4</b>	<b>Assembly</b> .....	<b>9</b>	8.2	Safety instructions .....	33
4.1	Installation site .....	9	8.3	Overview of the maintenance tasks .....	33
4.1.1	Regulations concerning installation site .....	9	8.3.1	Checking the safety temperature limiter .....	34
4.1.2	Notes concerning the heating system and the installation site .....	9	8.3.2	Automatic gas firing system .....	34
4.2	Dimensions .....	10	8.3.3	Sealing .....	34
4.3	Recommended minimum distance for installation .....	12	8.3.4	Checking the combustion air and exhaust air ..	34
4.4	Boiler block, pre-assembled .....	13	8.3.5	Checking the exhaust gas installation .....	34
4.4.1	Scope of supply, boiler block, pre-assembled ..	13	8.3.6	Checking the gas setting .....	34
4.4.2	Scope of supply, cladding .....	14	8.3.7	Exhaust gas losses and combustion quality ..	34
4.4.3	Scope of supply, flow safety device .....	14	8.4	Maintenance tasks .....	35
4.4.4	Aligning the boiler block .....	15	8.4.1	Cleaning the burner .....	35
4.5	Installation of ancillary components .....	15	8.4.2	Cleaning the heat exchanger .....	36
4.6	Fitting the burners .....	17	8.4.3	Checking the gas setting .....	36
4.7	Connection of the electrical cable .....	18	8.4.4	Performing the exhaust gas measurement and checking the combustion quality .....	36
4.8	Completing the boiler .....	18	<b>9</b>	<b>Troubleshooting</b> .....	<b>37</b>
<b>5</b>	<b>Installation</b> .....	<b>20</b>	9.1	Error codes .....	37
5.1	General instructions for heating system .....	20	9.2	Resetting the interlock after switch-off by the safety temperature limiter (STL) .....	38
5.2	Gas connection .....	20	9.3	Status codes .....	38
5.3	Heating side connection .....	20	9.4	Diagnosis codes .....	38
5.4	Electrical installation .....	20	<b>10</b>	<b>Vaillant Service</b> .....	<b>40</b>
5.4.1	Notes for electrical installation .....	20	<b>11</b>	<b>Recycling and disposal</b> .....	<b>40</b>
5.4.2	Connecting the mains feed .....	21	11.1	Appliance .....	40
5.4.3	Connecting the sensors and setting motors .....	21	11.2	Packaging .....	40
5.4.4	Electrical connection plan with system Pro E..	22	<b>12</b>	<b>Technical data</b> .....	<b>41</b>
5.4.5	Connection of external accessories and control units .....	24			
5.4.6	Connecting external sensors, control units (accessories) .....	25			
<b>6</b>	<b>Start-up</b> .....	<b>25</b>			
6.1	Filling the installation .....	25			
6.1.1	Water preparation in heating installations .....	25			
6.1.2	Preparing for operation .....	26			

## 1 Notes on the documentation

The following information is intended to help you throughout the entire documentation. Further documents apply in combination with this installation and maintenance manual.

**We accept no liability for a damage caused by failure to observe these instructions.**

### Documents which are also valid and auxiliary service equipment

#### For the owner of the system:

Operating manual no. 838364

The manuals for any accessories and controllers used also apply.

### Auxiliary service equipment:

The following test and measuring equipment are required for inspection and maintenance:

- CO<sub>2</sub>-measuring instrument
- Pressure gauge

### 1.1 Storage of the documents





The short-form instructions are glued onto the top section of the control field cover. You can enter the individual capacity data of the boiler and your address next to this.

Please pass on this operating and installation manual and all other valid documents to the owner of the installation in order for him or her to store it so that it is available whenever it is required.

### 1.2 Symbols used

Please observe the safety instructions in this installation manual for the installation of the appliance.

The symbols used in the manual are explained below:

-  **Danger!**  
**Danger of death by electrocution!**
-  **Danger!**  
**Immediate risk of serious injury or death**
-  **Caution!**  
**Potentially dangerous situation for the product and environment.**
-  **Note!**  
**Useful information and instructions**

- Symbol for a necessary task

## 2 Description of the appliance

### 2.1 Identification plate

The identification plate is mounted on the back of the electronic box.

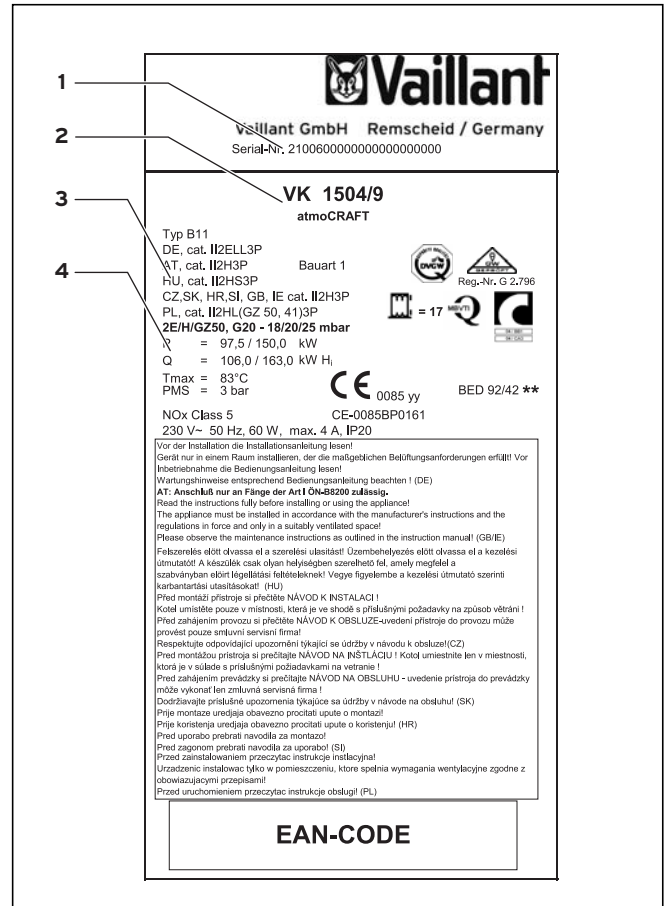

Fig. 2.1 Identification plate

The following information can be taken from the identification plate:

- 1 Manufacturing number
- 2 Type name
- 3 Designation of the type approval
- 4 Technical data

## 2 Description of the appliance

### 2.2 CE label

CE labelling shows that the appliances comply with the basic requirements of the following directives:

- Gas appliances directive (90/396/EEC)
- Electromagnetic compatibility directive with threshold class B (89/336/EEC)
- Low voltage directive (73/23/EEC)

The appliances meet the basic requirements of the efficiency requirements directive (Council Directive 92/42/EEC) as low temperature boilers.

Just for Germany:

In accordance with the requirements in accordance with § 7 of the Regulations for Small Combustion Installations dated 07.08.1996 (1. BImSchV), the above equipment emits less than 80 mg/kWh nitrogen dioxide (NO<sub>x</sub>) when operating with natural gas.

### 2.3 Intended use

The Vaillant atmoCRAFT boilers are state-of-the-art appliances which have been constructed in accordance with recognised safety regulations. Nevertheless, danger to the life and limb of the user or third parties can still occur or the appliance or other material assets be impaired in the event of improper use.

The appliance is designed to generate heat for closed hot water central heating systems and for central hot water supply. Any other use or extended use is considered to be improper. The manufacturer or supplier is not liable for any resulting damage. The user alone bears the risk.

Intended use includes the observance of the operating and installation manual and the adherence to the inspection and maintenance conditions.



#### **Caution!**

**Any improper use is forbidden.**

The appliances must be installed by a heating engineer, who is responsible for adhering to the existing regulations, rules and guidelines.

### 2.4 Structure of atmoCRAFT

The Vaillant atmoCRAFT gas boilers are used generate heat for hot water central heating systems and for central hot water supply.

They are suitable for operation in new installations and for modernisation of existing heating installations in single and multi-occupancy houses and in business units. The atmoCRAFT boiler type is a low temperature boiler and is operated in combination with a VRC heating controller with floating reduced boiler water temperature.

The structure and operational behaviour of the boilers complies with the requirements of DIN EN 656. They are tested from a heating technology point of view and have the CE mark on the identification plate.

### 2.5 Scope of delivery and accessories

The Vaillant atmoCRAFT gas boilers are pre-assembled and delivered on two pallets.

Check the delivery for completeness using the following table.

Amount	Description
Pallet 1	Cladding components, flow safety device, electronic box cladding
Pallet 2	Baseplate, heat exchanger, burners, exhaust manifold, electronic box, insulation, small items (completely assembled), cleaning brush

**Table 2.1 Scope of supply pre-assembled**

The exact scope of supply of the individual packaging units on the pallets is listed in the individual sections. Check the scope of supply for completeness using the tables given in these locations.

The following accessories are required for the installation of the unit:

- Exhaust gas accessories; see the installation instructions for further information concerning planning and installation
- Controller
- Gas ball-cock with fire protection unit
- Safety valve, heating side
- Expansion vessel
- Pressure gauge

## 2.6 Type overview

The Vaillant atmOCRAFT gas boilers are supplied with the following capacities:

Appliance type	Nominal heat capacity P (kW)	Designated country (designation in accordance with ISO 3166)	Approval category	Type of gas
VK 654/9	65.0 (80/60 °C)	GB (Great-Britain)	II <sub>2H3P</sub>	G20 (natural gas H) G31 (liquid gas)
VK 754/9	75.0 (80/60 °C)			
VK 854/9	85.0 (80/60 °C)			
VK 1054/9	105.0 (80/60 °C)			
VK 1154/9	115.0 (80/60 °C)			
VK 1304/9	130.0 (80/60 °C)			
VK 1504/9	150.0 (80/60 °C)			
VK 1654/9	165.0 (80/60 °C)			

**Table 2.3** Type overview

## 2 Description of the appliance

### 2.7 Functional and operating elements

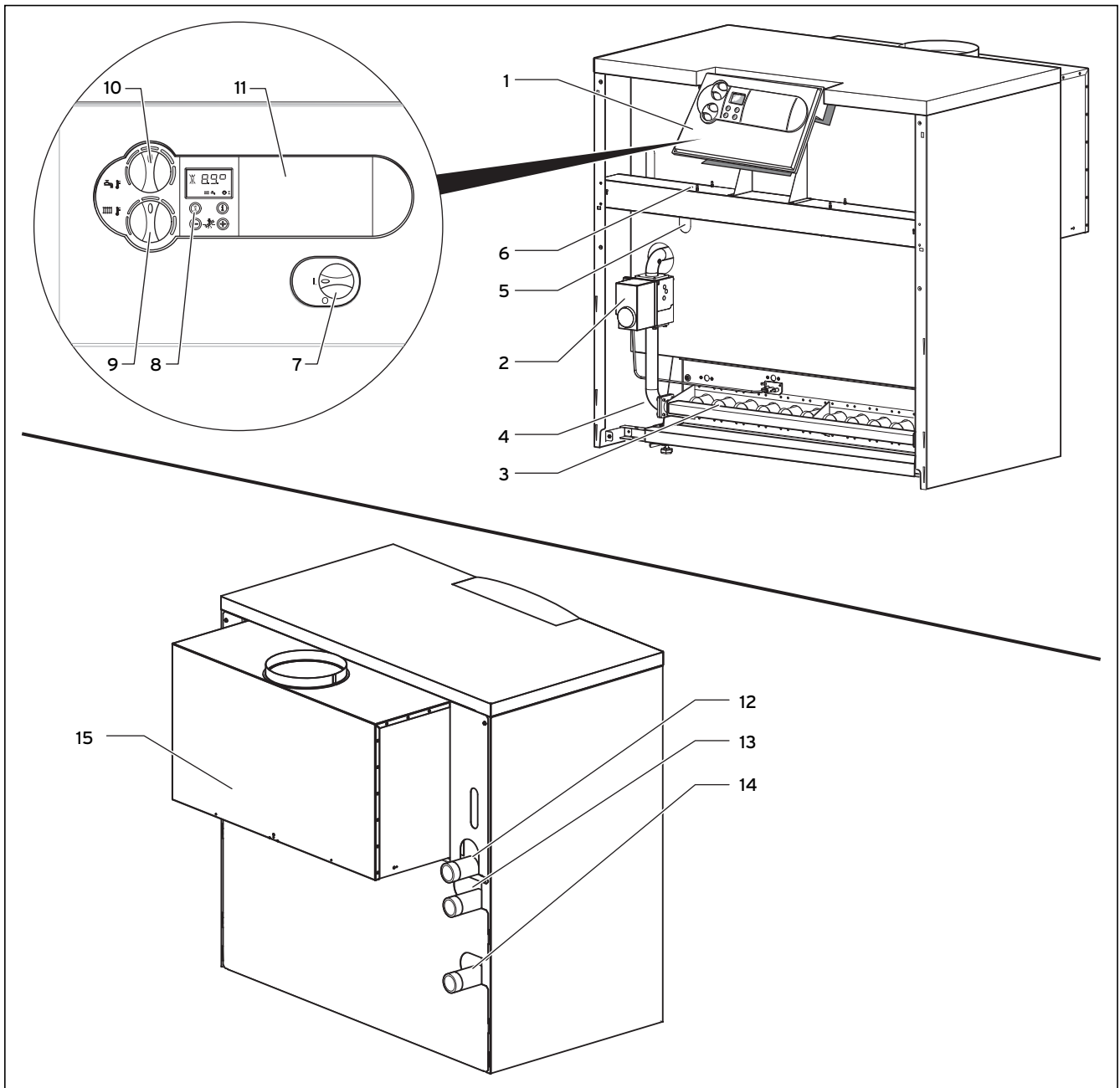

Fig. 2.1 Overview of the functional elements

**Key:**

- 1 Electronic box
- 2 Gas fitting
- 3 Burner
- 4 Boiler filling and drain cock
- 5 Immersion sleeve
- 6 Safety temperature limiter STL

**Operating elements of the control box:**

- 7 Main ON/OFF switch
- 8 Digital information and analysis system with display
- 9 Feed temperature controller
- 10 Storage tank temperature controller
- 11 Mounting positions for Vaillant control units

**Connections on the back of the boiler:**

- 12 Heating feed connection (HVL)
- 13 Gas connection
- 14 Heating return connection (HRL)
- 15 Flow cutout



### 3 Safety instructions and regulations

#### 3.1 Safety instructions

##### Assembly

The combustion air fed to the unit must be free of chemicals which contain, e.g. fluorine, chlorine or sulphur. Sprays, solvents or cleaning agents, paints and adhesives can contain such materials which can, in certain circumstances, lead to corrosion when operating the unit, including the exhaust gas installation.

In business premises such as hairdressing salons, painting or carpentry workshops, cleaning businesses etc., also when operating in room-air independent mode, a separate room must always be used for the installation which will ensure that the supply of combustion air is technically free from chemicals.

It is not necessary to keep a clearance between the appliance and combustible materials or components, as at the rated heating power of the appliance, the temperature here is always lower than the permitted temperature of 85 °C.

Clearances in accordance with Section 4.3 must be maintained for maintenance purposes.

##### Note concerning flue design:

The double stage system of the boiler with combustion air matching produces high values of combustion technological effectivity. This requires technical evidence of the suitability of the flue in according with the relevant standards.

##### Installation

Before the installation of the boiler, the comments of the gas supply company and the district chimney sweep must be obtained.

The boiler may only be installed by a suitably qualified heating engineer, who also assumes the responsibility for installing the appliance properly and putting it into service for the first time.

Flush the heating system thoroughly before connecting the appliance! By doing that, residue such as welds, cinder, hemp, putty, rust, rough dust and similar substances are removed from the pipes. Otherwise such substances can be deposited in the appliance and cause damage.

Make sure that the connection and gas pipes are not under stress when installed to avoid leakage in the heating installation or in the gas connection!

To tighten or loosen bolts, only use suitable open-ended spanners (do not use pliers or extensions etc.). Improper use or unsuitable tools can cause damage, such as gas or water leaks.

On closed heating installations, a type-approved safety valve corresponding to the heat capacity must be fitted. The gas regulating block may be tested for leakage only with a maximum pressure of 50 mbar! Higher testing pressures can damage the gas fitting.

The electrical installation may only be performed by a heating engineer.

There is a danger to life by electrocution from current-carrying components! The supply terminals in the terminal box of the device are under voltage even if the mains switch is off. Before working on the appliance, turn off the power supply and secure against restart.

##### Important instructions for propane appliances

Bleeding the liquid gas tank when installing the system: before installing the device, make sure that the gas tank has been bled. The liquid gas supplier is responsible for the proper bleeding of the tank. Ignition problems can be caused if the tank is not bled properly. In such cases, first contact the person in charge of filling the tank.

##### Affix tank sticker:

Affix the enclosed tank sticker (propane quality) on the tank where it is clearly visible, if possible close to the filler nozzle.

##### Start-up

Do not add frost or corrosion preventative to the heating water! If frost or corrosion preventative is added to the heating water this can cause changes in the seals and can cause noises to be created during the heating process. Vaillant assumes no liability for this and such consequential damages. Please inform the user of the procedure for frost protection. If the heating water hardness is above 3,6 mol/m<sup>3</sup> (20 °dH) it should be softened. To do this you can use the ion-exchanger, Vaillant spare part number 990 349. Please observe the enclosed operating instructions.

##### For natural gas:

If the connected pressure is outside the range 17 to 25 mbar, the unit must not be operated!

##### For liquid gas: (37 mbar)

If the connected pressure is outside the range 35 to 45 mbar, the unit must not be operated!

##### Inspection and maintenance

Inspection, maintenance and repair work should only be undertaken by an approved heating installation company. Inspections / Maintenance work not carried out can result in damage to property and personal injury.

Risk of fatal electric shock from touching live connections! The supply terminals in the terminal box of the device are under voltage even if the mains switch is off. Before working on the appliance, turn off the power supply and secure against restart.

Protect the switch box from water splashes.

Danger of explosion through gas leakage! The mixer tube between the gas control unit and burner must not be opened. It can only be guaranteed that this component is gas-proof after it has been checked at the factory.

## 3 Safety instructions and regulations

There is danger of being injured or scalded by the boiler and by all components carrying water. Only carry out work on these components once they have cooled down.

### Troubleshooting

Disconnect the unit from the mains before starting to work. Close the gas valve and the maintenance valves. Empty the appliance if you want to replace water-bearing components of the appliance!

Risk of fatal electric shock from touching live connections! The supply terminals in the terminal box of the device are under voltage even if the mains switch is off. Before working on the appliance, turn off the power supply and secure against restart.

Make sure that no water drips onto live components (e.g. electronic box etc.)!

Use only new gaskets and O-rings!

Once you have finished this work run a test.

### 3.2 General requirements

#### 3.2.1 Preliminary remarks for room sealed appliances

This appliance should only be installed in conjunction with either a Vaillant flue system or an alternative approved system (details of flue approval categories can be found in the technical section of the installation manual).

Install the flue system as detailed in the separate flue installation instructions supplied with this boiler.

#### 3.2.2 Related documents

The installation of the boiler must be in accordance with the relevant requirements of Gas Safety (Installation and Use) Regulations 1998, Health and Safety Document No. 635 (The Electricity at Work Regulations 1989), BS7671 (IEE Wiring Regulations) and the Water Supply (Water Fitting) Regulations 1999, or The Water Bylaws 2000 (Scotland). It should also be in accordance with the relevant requirements of the Local Authority, Building Regulations, The Building Regulations (Scotland), The Building Regulations (Northern Ireland) and the relevant recommendations of the following British Standards:

- BS 6700: Services supplying water for domestic use within buildings and their curtilages.
- BS 6798: Specification for installation of gas fired boilers not exceeding 60kW input.
- BS 6891: Specification for installation of low pressure gas pipework up to 28 mm (R1) in domestic premises (2nd family gas).
- BS 7593: Treatment of water in domestic hot water central heating systems.
- Institute of Gas Engineers Publication IGE/UP/7/1998: "Guide for gas installations in timber framed housing"
- BS. 5482 Pt. 1: Domestic butane and propane gas burning installations.
- IGE/UP1: Soundness testing and purging of industrial and commercial gas installation.
- IGE/UP2: Gas installation pipework, boosters and

- compressors on industrial and commercial premises.
- IGE/UP10: Installation of gas appliances in industrial and commercial premises.
- BS. 6644: Installation of gas fired hot water boilers of rated inputs between 60kW and 2MW (2nd and 3rd family gases).
- BS. 5449: Forced circulation hot water central heating systems for domestic premises. Note: only up to 45kW.
- BS. 6880: Low temperature hot water heating systems of output greater than 45kW.
  - Part 1: Fundamental and design considerations.
  - Part 2: Selection of equipment.
  - Part 3: Installation, commissioning and maintenance.
- BS. 4814: Specification for: Expansion vessels using an internal diaphragm, for sealed hot water heating systems.
- BS. 5440: Installation and maintenance of flues and ventilation for gas appliances of rated input not exceeding 70kW net (1st, 2nd and 3rd family gases).
  - Part 1: Specification for installation of flues.
  - Part 2: Specification for installation and maintenance of ventilation for gas appliances.

## 4 Assembly

### 4.1 Installation site

#### 4.1.1 Regulations concerning installation site

The approval of the relevant building regulations authority must be obtained for the selection of the installation site and for the characteristics of the ventilation and exhaust gas handling systems of the installation room.

The combustion air fed to the unit must be technically free of chemicals which contain, e.g. fluorine, chlorine or sulphur. Sprays, paints, solvents and cleaning materials and adhesives contain such substances, which can, during operation of the unit, lead to corrosion under certain conditions, including in the exhaust gas installation. If the installation is to take place at the site of erection, a water pressure test at a test pressure of 5,2 bar should be performed. The equipment manufacturer must, in this case, issue a certificate to say that the water pressure test has been performed. Separation of the unit from structural components of flammable material by a specified distance is not required. Since, at nominal heating output of the unit, temperatures in excess of the permissible temperature of 85 °C are not created, we recommend the clearances shown in Section 4.3.

Clearances in accordance with Section 4.1 to 4.3 must be maintained for maintenance purposes.

If the boiler is to be installed on a flammable floor (e.g. wood, PVC or similar), the boiler must be placed on an underlay of non-flammable material.

#### 4.1.2 Notes concerning the heating system and the installation site

- From the blow-off line of the safety valve, there must be a drain pipe with inlet funnel and syphon fitted by the user to a suitable drain (connection to the waste water system) within the installation room. The drain must be visible!
- The safety temperature limiter fitted to the boiler also serves as a shortage of water safety device.
- The switch-off temperature of the boiler in the event of a malfunction is ca. 110 °C.  
A suitable thermostat must be mounted in the heating feed line by the user if plastic pipes are used in the installation. This is required to protect the heating installation from temperature-related damage. The thermostat can be wired electrically into the plug location for the plant thermostat of the Pro E system.
- In the case of installation volumes in excess of 15 l/kW heating capacity, suitable hydraulic protection switching must be installed.
- The boiler should be installed in a frost-protected room in the vicinity of the exhaust gas chimney. The permissible ambient temperature for operation of the boiler is between + 3 °C and + 45 °C.

- When selecting the installation location, the weight of the boiler, including the water contained within it, shown in the table "Technical Data" and the type of chimney construction must be taken into account.

## 4 Assembly

### 4.2 Dimensions

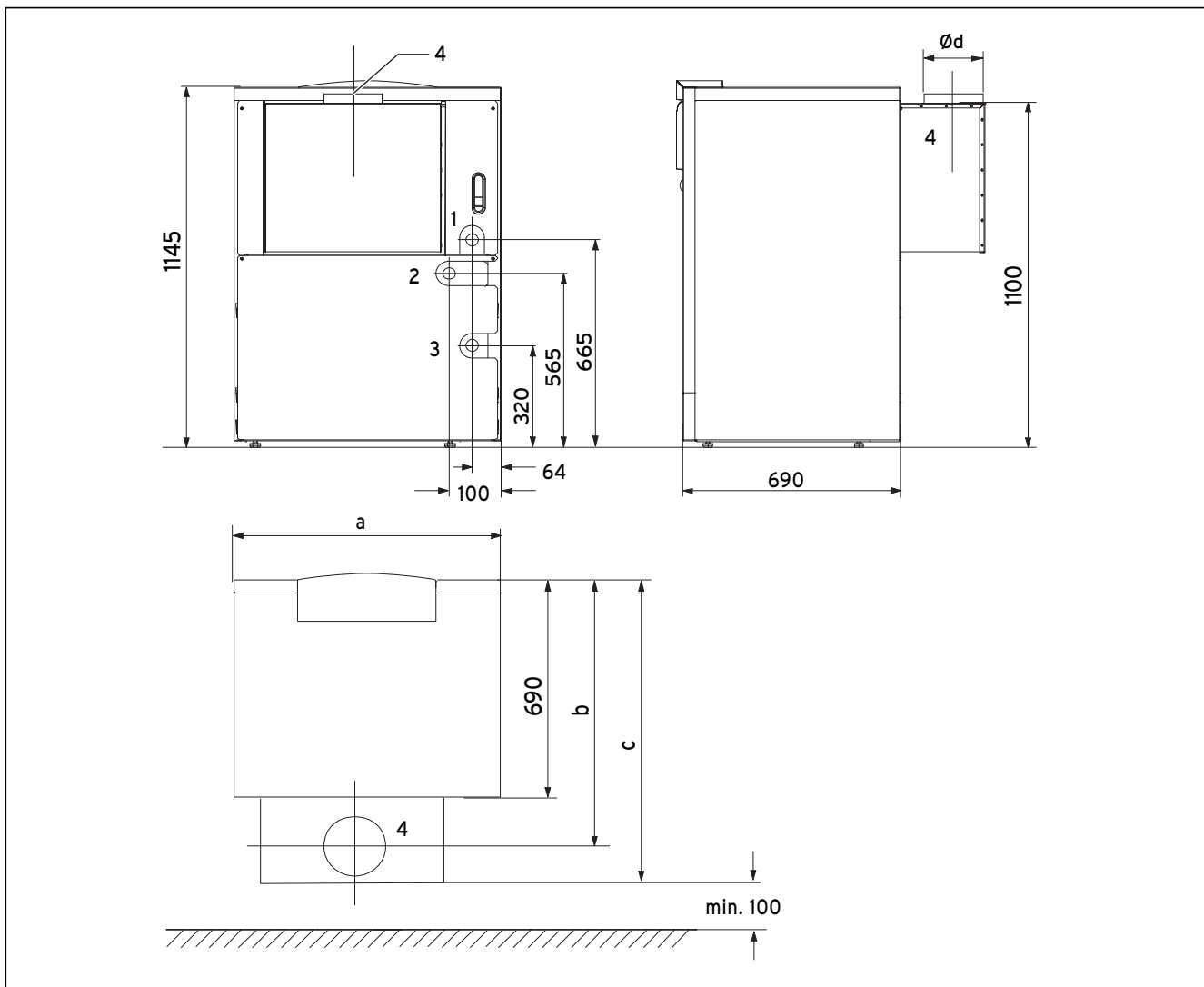

Fig. 4.1 Dimensions for VK in mm

**Key:**

- 1 Heating feed
- 2 Gas connection
- 3 Heating return
- 4 Flue gas connection

Boiler Type	A	B	C	$\varnothing d$	Heating feed/ Heating return	Gas connection
65 kW	850	860	960	180	R 1 1/2	R 1
75 kW	930	850	960	200	R 1 1/2	R 1
85 kW	1010	850	960	200	R 1 1/2	R 1
105 kW	1170	838	960	225	R 1 1/2	R 1
115 kW	1250	838	960	225	R 1 1/2	R 1
130 kW	1410	825	960	250	R 1 1/2	R 1 1/4
150 kW	1570	825	960	250	R 1 1/2	R 1 1/4
165 kW	1730	852	1012	300	R 1 1/2	R 1 1/4

Table 4.1 Dimensions (measurements in mm)

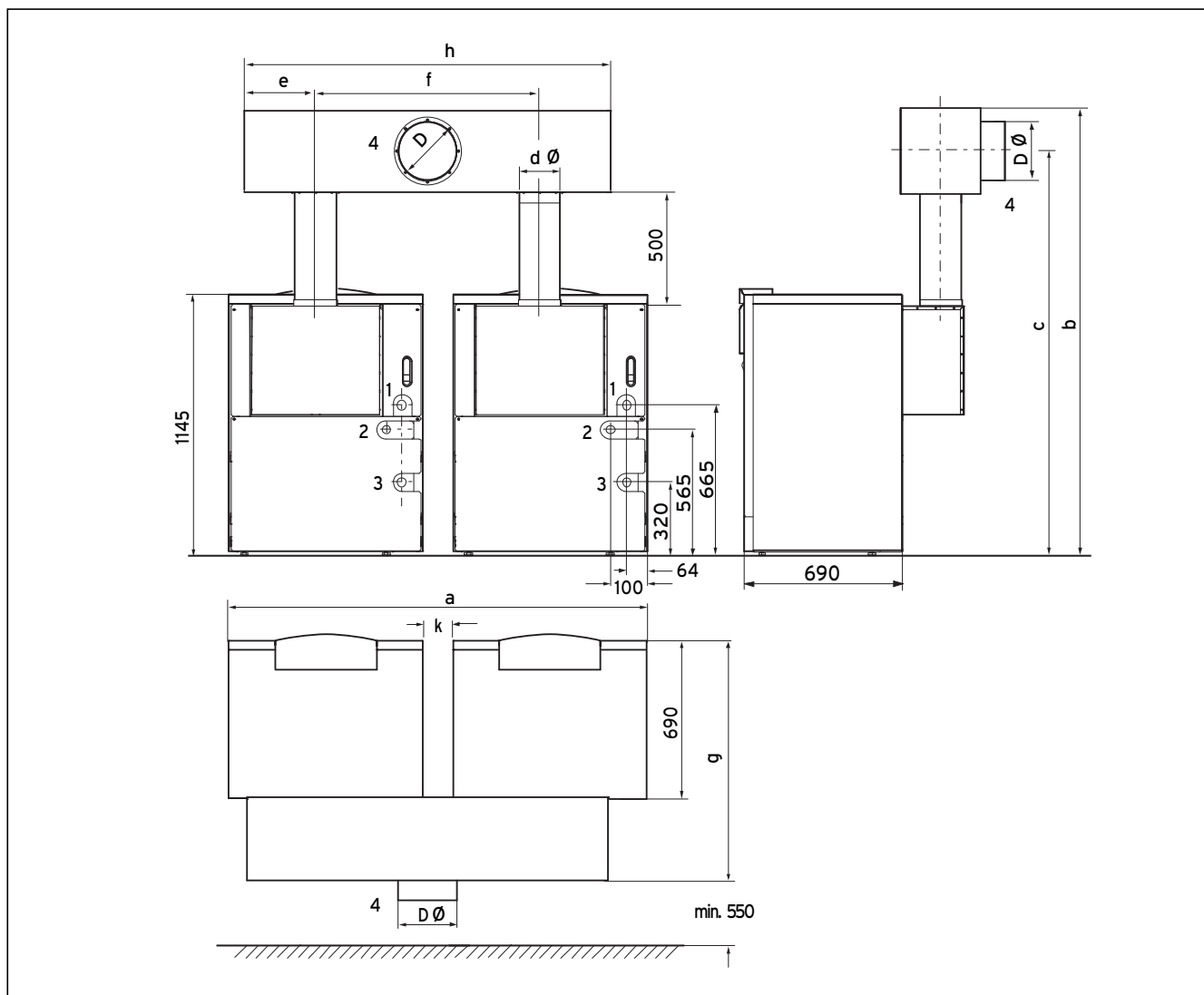

Fig. 4.2 Dimensions for VKM in mm

**Key:**

- 1 Heating feed
- 2 Gas connection
- 3 Heating return
- 4 Flue gas connection

Boiler Type	A	B	C	$\varnothing d$	$\varnothing d$	A	F	g	h	R	Exhaust manifold: Size designation	Exhaust manifold: Length in mm
VKM 1304	1830	1950	1773	180	250	310	980	1048	1600	130	I	1600
VKM 1504	1990	1950	1773	200	280	270	1060	1038	1600	130	I	1600
VKM 1704	2070	1950	1773	200	280	270	1060	1038	1600	50	I	1600
VKM 2104	2470	1986	1791	225	325	260	1300	1043	1820	130	II	1820
VKM 2304	2550	1986	1791	225	325	260	1300	1043	1820	50	II	1820
VKM 2604	3030	2026	1811	250	350	260	1620	1050	2140	210	III	2140
VKM 3004	3190	2026	1811	250	350	260	1620	1050	2140	50	III	2140
VKM 3304	3510	2026	1811	300	400	180	1780	1077	2140	50	III	2140

Table 4.2 Dimensions (measurements in mm)

## 4 Assembly

### 4.3 Recommended minimum distance for installation

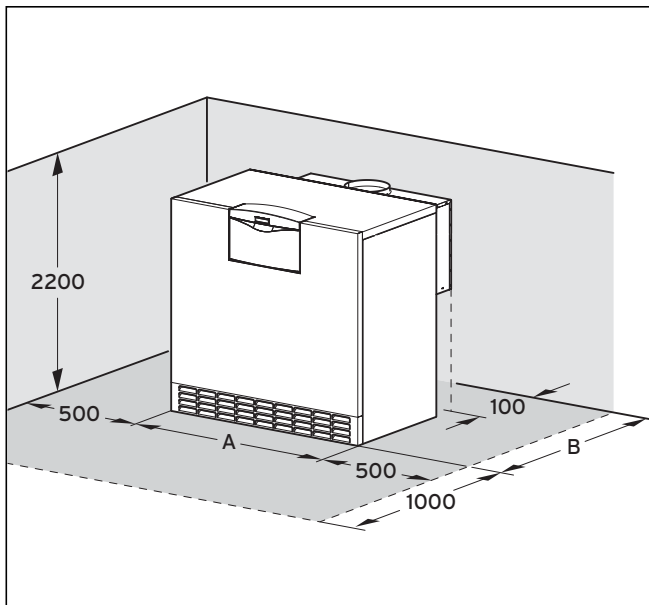

**Fig. 4.3 Minimum clearances**

When installing the boiler, the minimum clearances shown in Fig. 4.3 must be maintained to ensure unhindered access to the boiler.

The height of the boiler room should be at least 2200 mm (also with VKM). The side clearances and the clearance in front of the unit shown in the drawing are for maintenance purposes.



**Note!**

**Please bear in mind that, when installing a free-standing boiler, there is adequate free space on both sides (min. 500 mm) for the installation process.**

Boiler Type	A	B
65 kW	850	1060
75 kW	930	
85 kW	1010	
105 kW	1170	
115 kW	1250	
130 kW	1410	
150 kW	1570	1112
165 kW	1730	

**Table 4.3 Dimensions (measurements in mm)**

#### 4.4 Boiler block, pre-assembled

**Note!**  
 Here you will find the scope of supply of the pre-assembled boiler block. For additional installation see Chapter 4.5.

##### 4.4.1 Scope of supply, boiler block, pre-assembled

Check the scope of supply in accordance with the adjacent illustration and table for completeness and lack of damage.

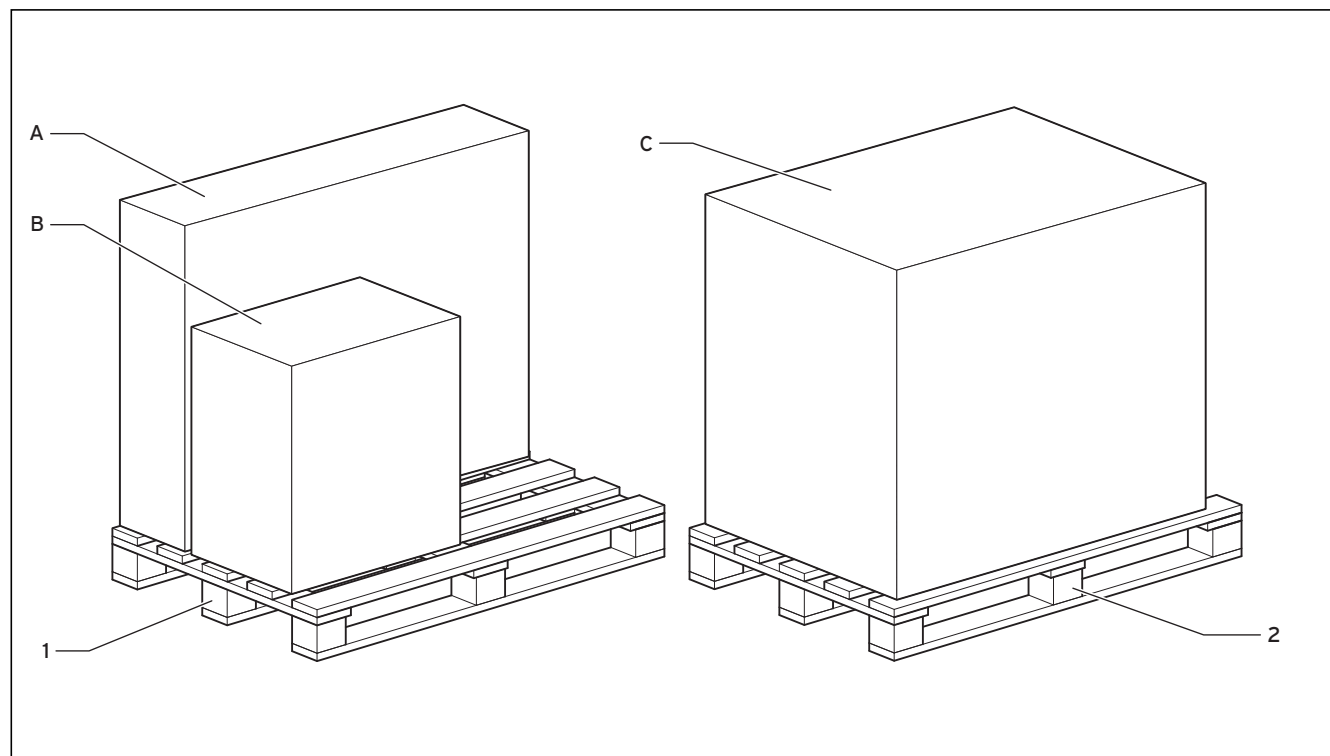

Fig. 4.4 Scope of supply boiler block, pre-assembled

Pallet	Description	Unit
1	Cladding	A
	Flow safety device, hood electronic box	B
2	Exhaust gas manifold and Burners and Insulation and Heat exchanger, complete pre-assembled on the baseplate	C
	Electronic box (packed loose)	
	Small items	
	Cleaning brush	

Table 4.4 Scope of supply, boiler block, pre-assembled

## 4 Assembly

### 4.4.2 Scope of supply, cladding

Check the scope of supply in accordance with the adjacent illustration and table for completeness and lack of damage.

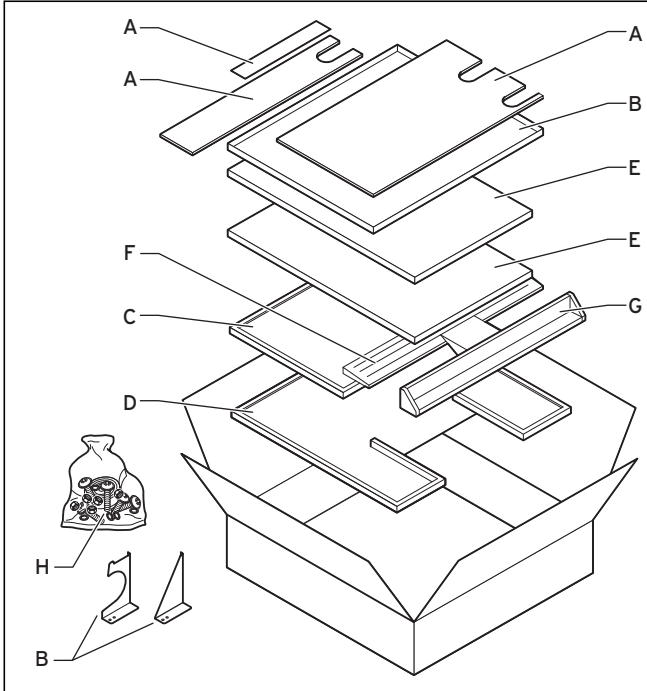

Fig. 4.5 Scope of supply cladding

Description	
Back wall plates (1 x large, 2 x small)	A
Intermediate plate and 2 brackets (left and right)	B
White cover	C
White front plate	D
2 x white side parts	A
1 x white ventilation grating	F
Cross-beam with electronic box holder	G
Loose items (bolts/fixing elements)	H

Table 4.5 Scope of supply, cladding

### 4.4.3 Scope of supply, flow safety device

Check the scope of supply in accordance with the adjacent illustration and table for completeness and lack of damage.

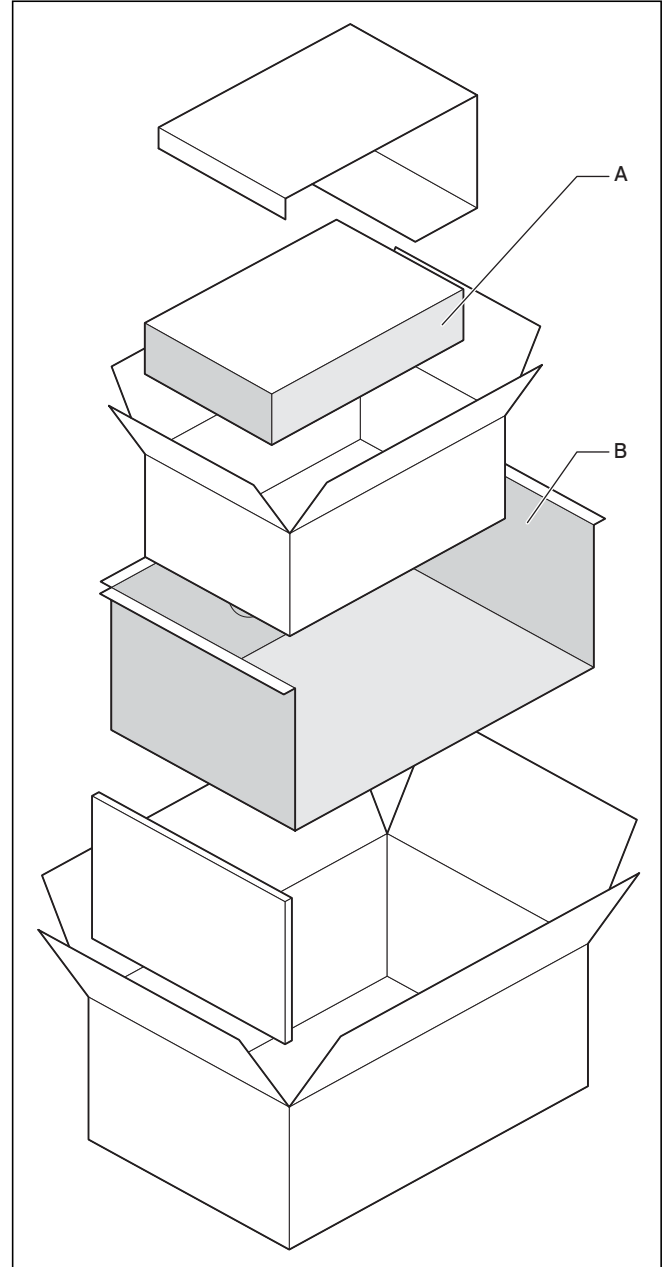

Fig. 4.6 Scope of supply flow safety device

Description	
Hood electronic box	A
Flow cutout	B

Table 4.6 Scope of supply, flow safety device



#### 4.4.4 Aligning the boiler block

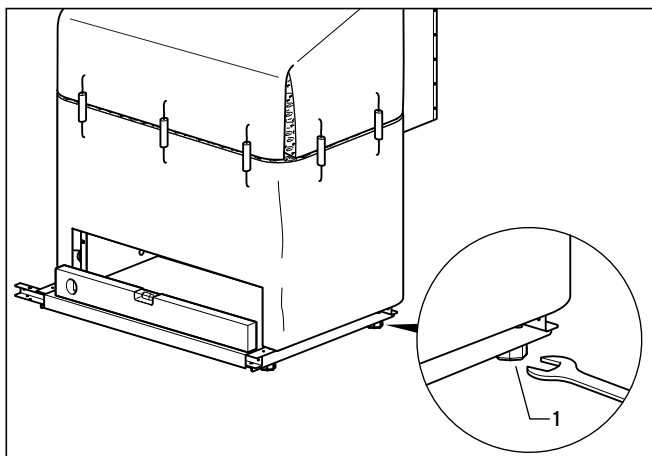

Fig. 4.7 Aligning boiler block

The boiler block must be level.

**Note!**  
Under no circumstances should there be an incline to the side of the plug in the upper boss, otherwise air bubbles could form in the boiler block.

- Level the boiler block using the adjustable boiler feet (1, SW 30) on the baseplate at the site of installation.
- Completely connect the boiler to the water supply and check for leaks at an excess pressure of **maximum 6 bar**. Use a calibrated pressure gauge since the mains water pressure can be considerably higher.

#### 4.5 Installation of ancillary components

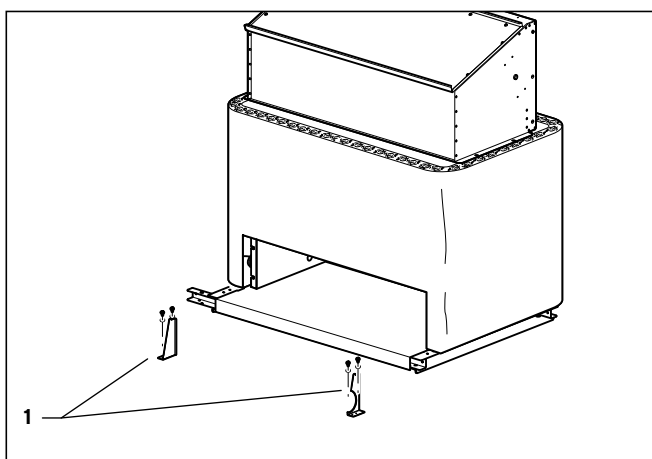

Fig. 4.8 Fitting the brackets

- Bolt the two brackets (1) right and left to the baseframe.

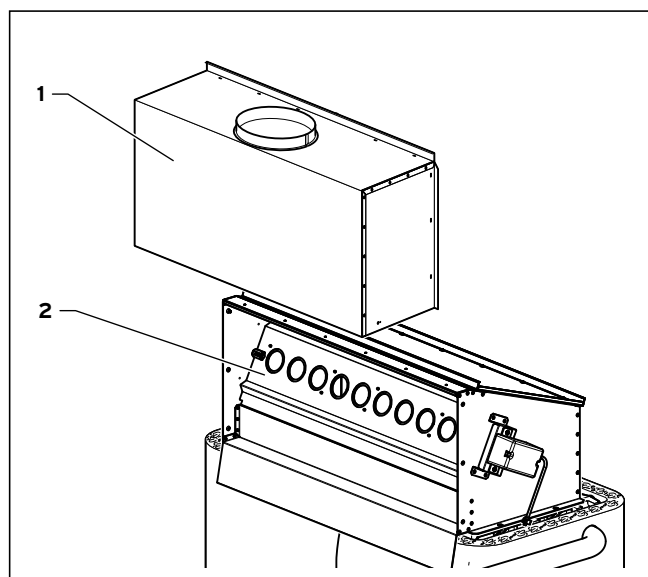

Fig. 4.9 Fitting the flow safety device

- Place the flow safety device (1) onto the exhaust gas manifold (2).
- Screw the flow safety device at the top, right and left, to the exhaust gas manifold using self-tapping screws.
- Check for leaks from the flow safety device on the exhaust gas manifold. It should be located flat and properly sealed.

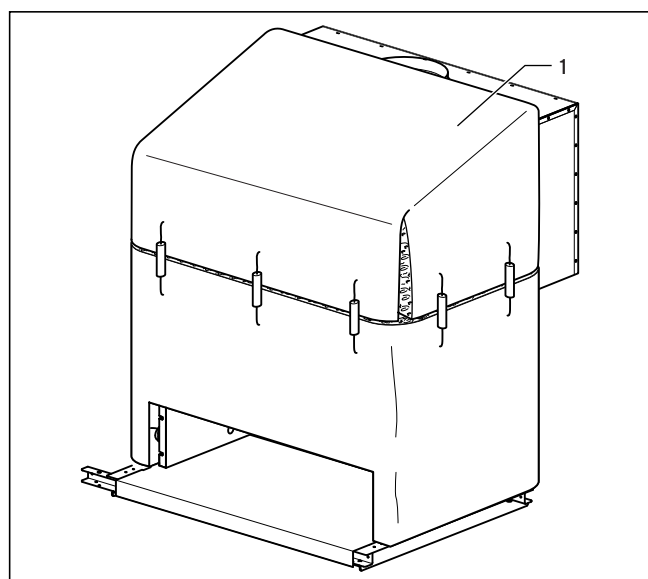
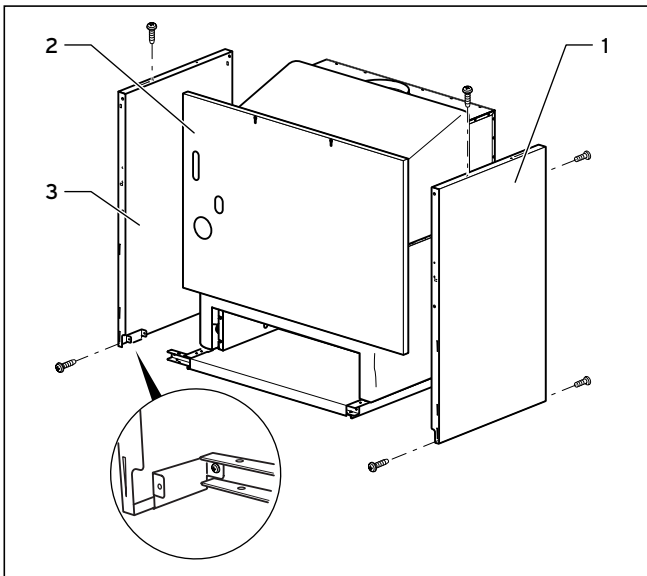

Fig. 4.10 Insulating the exhaust gas manifold

- Apply the insulation (1) to the exhaust gas manifold. When doing this, make sure that the insulation fits snugly round the exhaust gas manifold.
- Fix the insulation to the insulation of the boiler block using the clamping springs provided.

## 4 Assembly



**Fig. 4.11 Fitting the intermediate plate and side plates**

- Fix one side plate (1) to the baseframe front and back with two screws.
- Screw the intermediate plate (2) in front of the boiler. The intermediate plate is placed on the brackets and screwed in position in the lower area with four screws.
- Fix the other side plate (3) to the baseframe front and back with two screws.
- Fix the side plates to the intermediate plate at the top with screws.

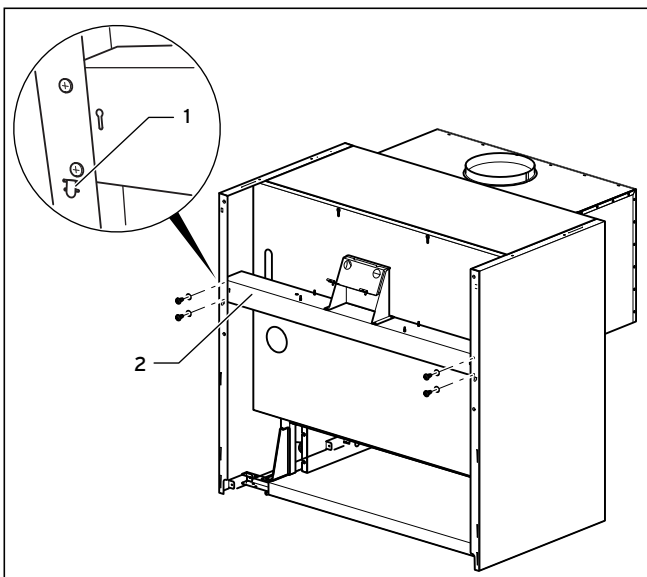

**Fig. 4.12 Fitting the cross-beam**

- Insert the projections (1) on the cross-beam (2) into the openings in the side plates and screw the cross-beam to the side plates left and right using two self-tapping screws on each.

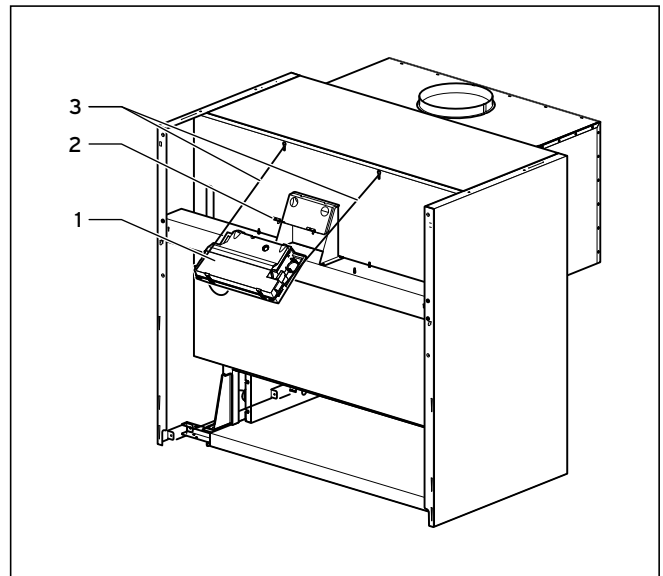

**Fig. 4.13 Mounting the electronic box**

- Now fit the electronic box (1).
- Push the box onto the holders (2) on the beam and fix the box with the retaining straps (3).

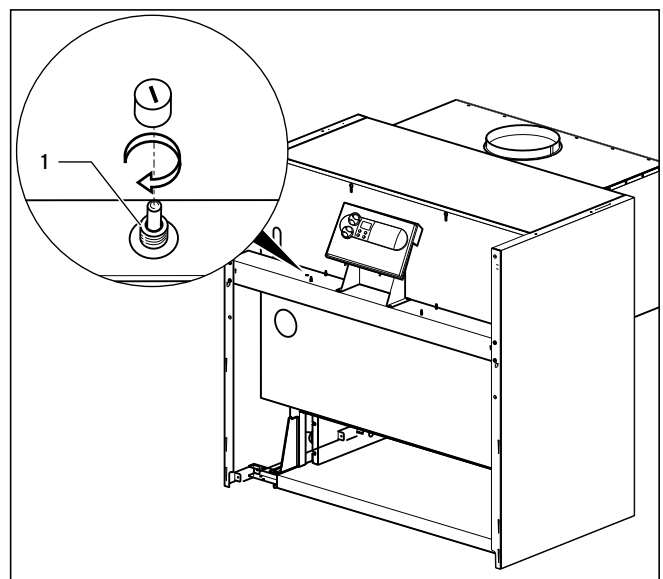

**Fig. 4.14 Fitting the STL**

- Fit the safety temperature limiter (STL) (1) onto the cross-beam on the left next to the electronic box.
- Connect the STL to the plug sockets provided in the electronic box.

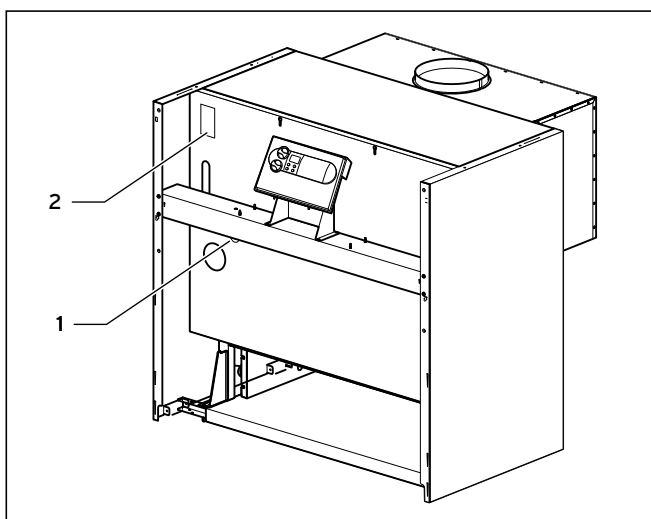

**Fig. 4.15** Inserting the temperature sensor into the immersion sleeve

- Insert the temperature sensor into the lower immersion sleeve (1) on the left of the boiler.
- Stick the enclosed identification plate (2) to the top left of the intermediate wall.

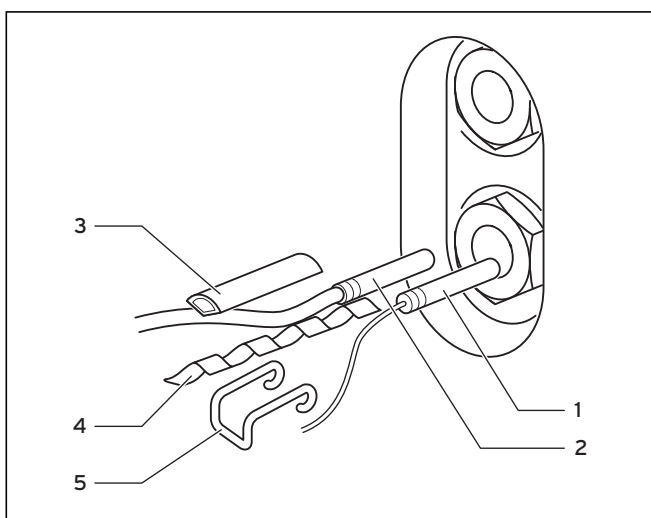

**Fig. 4.16** Inserting the temperature sensors into the immersion sleeves

- To do this you must insert the immersion sensor for STL (1, with capillary tube) and the temperature sensor (2, connect red plug to the electronic box) and the empty sleeve (3) into the bottom immersion sleeve.
- Place the clamping spring (4) between the immersion sensors and push them, together with the sensors into the immersion sleeve up to the stop.
- Lock everything in position using the clamping spring (5).

#### 4.6 Fitting the burners

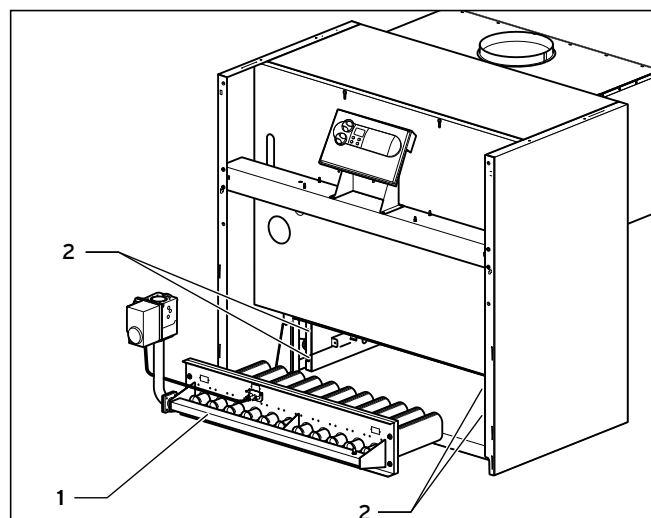

**Fig. 4.17** Inserting the burners

- Insert four screws in the pockets in the end links.
- Place the burner (1) onto the screws (2).
- **Make sure that no items are lying on top of the burner!**
- Loosely screw the burner onto the screws using the washers and hex nuts.

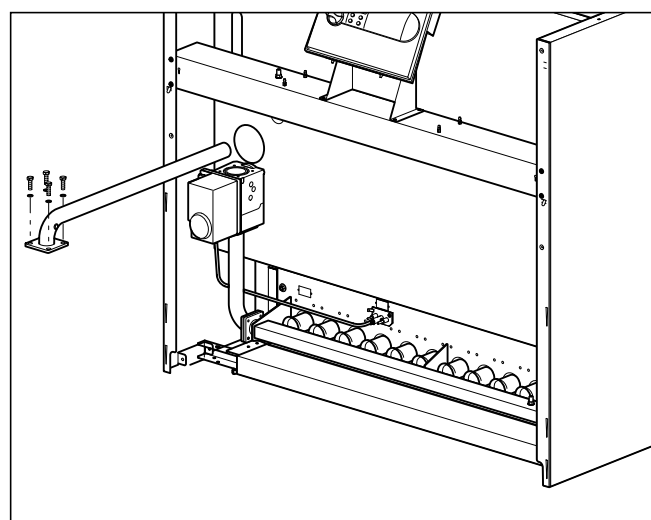

**Fig. 4.18** Fitting the gas connection line

- Remove the dust protection from the gas fitting.
- Check that the O-ring for sealing the gas connection line is securely located in the gas fitting.
- Push the pipe through to the back next to the boiler and screw the connection flange to the gas fitting. Above 130 kW the gas pipe must be pre-assembled from the two pipes supplied.

## 4 Assembly

### 4.7 Connection of the electrical cable

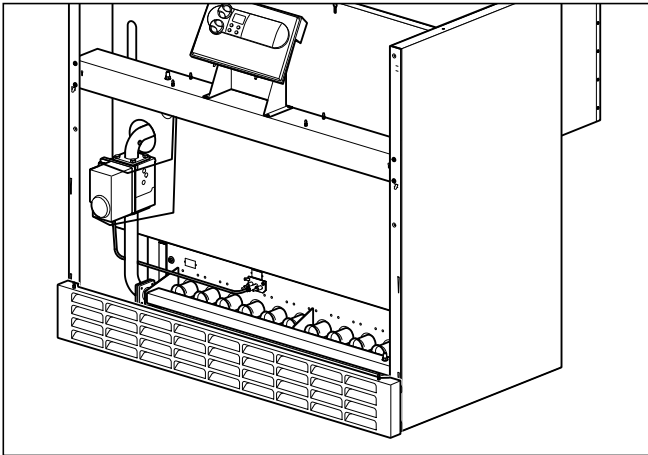

Fig. 4.19 Connecting the gas valves and the STL

- Connect the connection cable to the electronic box as shown in the electrical schematic drawing, see 5.4.3 and 5.4.4.

### 4.8 Completing the boiler

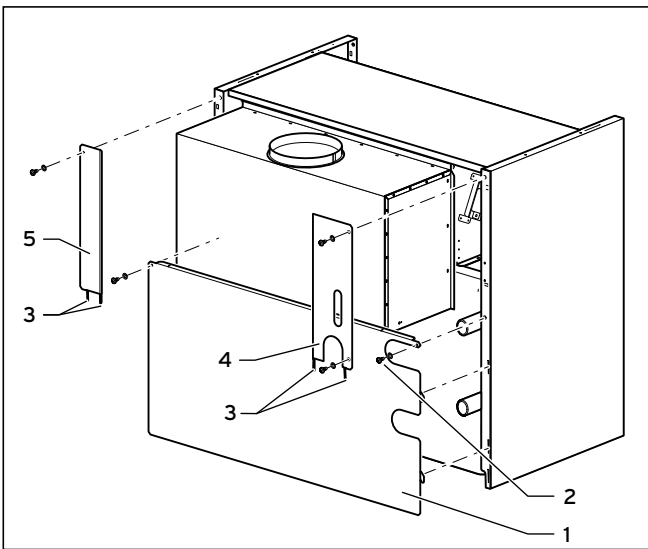

Fig. 4.20 Fitting the back wall plate

- Hang the back wall plate (1) into the receptacle in the side plates and secure it with one self-tapping screw (2) on the left and right hand sides.
- Insert the braces (3) of the additional back wall plates (4) and (5) into the back wall and screw both plates in position.



#### Note!

Make sure that all the plates are securely screwed together.

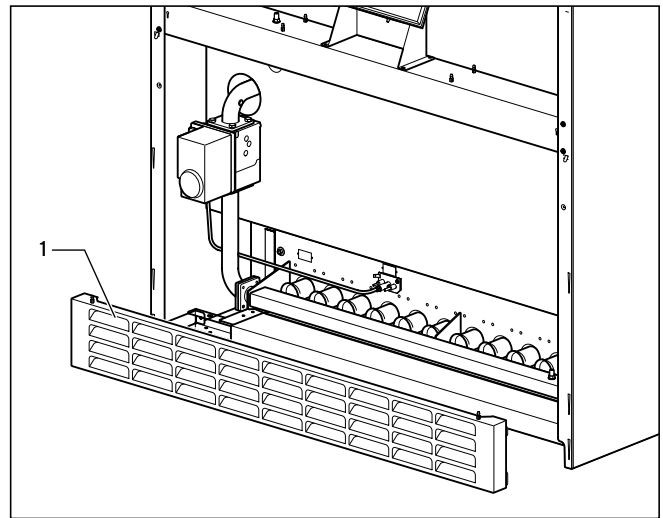

Fig. 4.21 Fitting the plinth adaptor

- Hang the plinth adaptor (1) into the lateral receptacles in the side pieces.

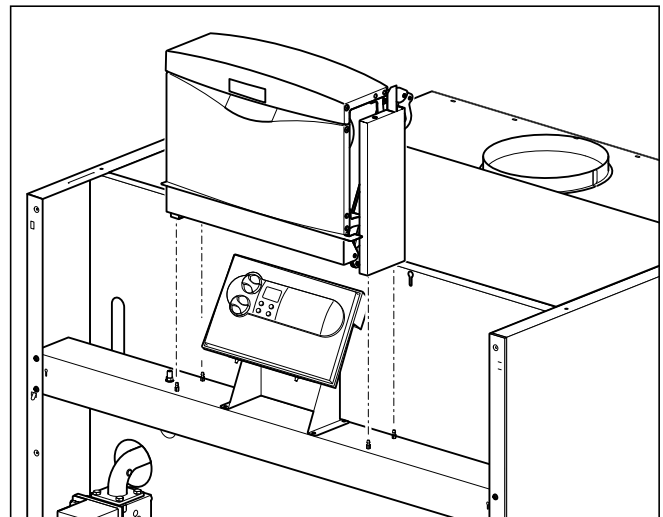

Fig. 4.22 Placing the cover of the electronic box in position

- Push the cover over the electronic box so that it clicks into place on the projection on the cross-beam.

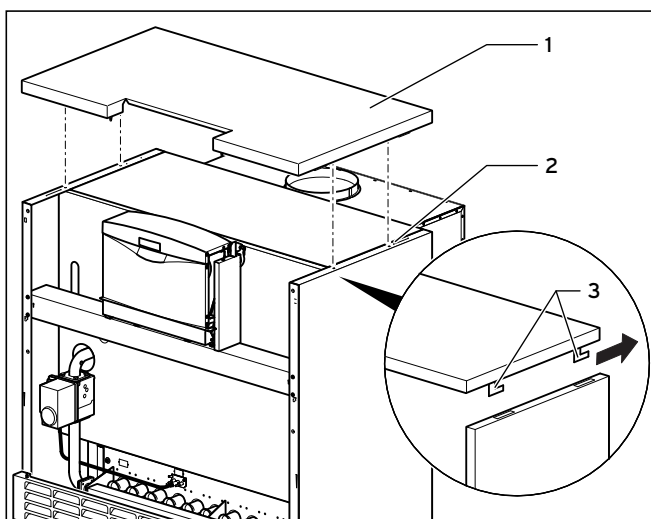

Fig. 4.23 Fitting the cover plate

- Place the cover plate (1) in position. The braces (3) of the cover plate should be inserted into the slots in the side plates (2). Then push the cover plate back until the front edge of the cover plate is in line with the side plates.

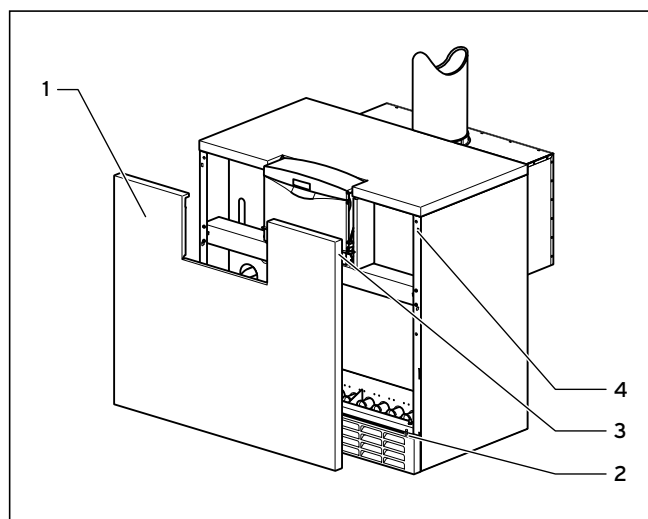

Fig. 4.25 Inserting the front plate

- Place the front plate (1) onto the pins (2) on the plinth rail.
- Push the front plate (1) using the two pins (3) into the retaining springs (4).

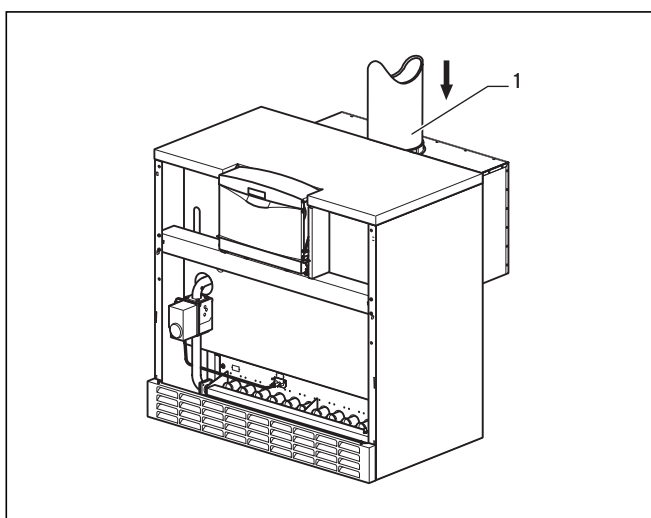

Fig. 4.24 Fitting the exhaust gas pipe

- Push the exhaust gas pipe (to be provided by the customer) (1) onto the flow safety device.



**Note!**

**Make sure that the exhaust gas pipe (1) is located tightly within the pipe connection of the flow safety device.**

# 5 Installation

## 5 Installation

### 5.1 General instructions for heating system



#### Caution!

**Flush the heating system thoroughly before connecting the appliance!**  
**By doing that, residue such as welds, cinder, hemp, putty, rust, rough dust and similar substances are removed from the pipes. Otherwise such substances can be deposited in the appliance and cause damage.**

### 5.2 Gas connection

The gas installation may only be established by an authorised engineer. The legal directives and the local regulations for gas supply companies must be observed. The gas infeed line must be laid out in according with local regulations, see Section 3.2.



#### Caution!

**Make sure that the connection and gas pipes are not under stress when installed to avoid leakage in the heating installation or in the gas connection!**

- A gas ball valve with fire protection device should be installed in the gas feed pipe to the unit. This must be located in an easily accessible position.
- Bolt the gas pipe to the gas connection flange (2) with a flat seal, see Figure 4.1. Insert a flat sealing nipple into the gas pipe to provide a seal.



#### Caution!

**The gas regulating block may be tested for leakage only with a maximum pressure of 50 mbar!**  
**Higher testing pressures can damage the gas fitting.**

- Check the gas connection with leak indicator spray for leakage.

### 5.3 Heating side connection

- Connect the heating feed to the heating feed connection (1), see Figure 4.1.
- Connect the heating return to the heating return connection (3), see Figure 4.1.
- Fit the required isolation devices between the heating installation and the boiler and fit the relevant safety devices.

### 5.4 Electrical installation

#### 5.4.1 Notes for electrical installation



#### Danger!

**Risk of fatal electric shock from touching live connections!**  
**Before working on the appliance, turn off the power supply and secure against restart.**

The electrical connection must be done by a suitably qualified heating engineer who is responsible for complying with the existing standards and guidelines. We specifically draw your attention to VDE Regulation 0100 and the regulations of the relevant EVU. Vaillant gas boilers are fitted with ProE System connection plugs for ease of wiring and are wired ready for connection. The mains infeed and all other connection cables (e.g. from the heating pump) can be connected to the ProE System plugs provided for the purpose (see Fig. 5.1 and 5.2). Mains and small voltage cable (e.g. sensor feed) must be physically separated and laid.

### 5.4.2 Connecting the mains feed

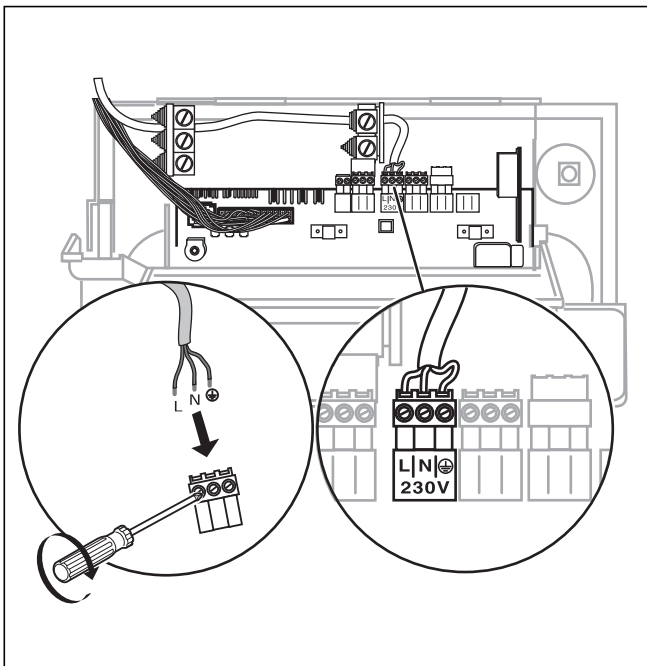

Fig. 5.1 Connecting the mains supply

The nominal voltage of the mains must be 230 V; if the mains voltage is more than 253 V and below 190 V functional impairment is possible.



#### Caution!

**The electronics can be destroyed by connecting the mains infeed to the wrong terminal plugs on the ProE System.**

**Only connect the mains infeed to the terminals marked for the purpose!**

The mains feed must be connected via a fixed connection and a separating device having a minimum contact opening of 3 mm (e.g. fuses, power switch). In the sub-distribution you must fit a 16 A fuse.

- Run the mains infeed cable to the connection level System Pro E in the boiler.
- Connect the mains feed securely to the ProE plug (see Fig. 5.1).

### 5.4.3 Connecting the sensors and setting motors

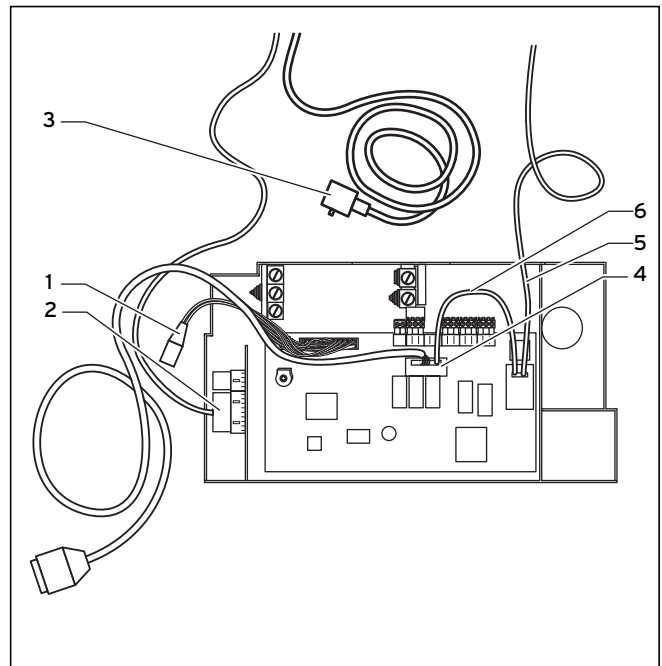

Fig 5.2 Connecting the sensors and setting motors

- Connect the connecting cable to the STL with the plugs (1, two flat plugs).
- Connect the connecting cable of the setting motor to plug (2) on the electronic box. The plug and the socket carry the same markings.
- Connect the other connecting cable of the setting motor to plug (3) on the gas fitting.
- Connect the connecting cable of the gas valve to plug (4) on the electronic box.



#### Note!

**The seals then need to be fitted to the pre-assembled electrical connections on the gas fitting. The seals are located in a plastic envelope which is fixed to the connection line with adhesive.**

- Connect the cable from the ignition electrode (5) to the ignition transformer.
- Connect the earth cable (6) to the ignition transformer.

# 5 Installation

## 5.4.4 Electrical connection plan with system Pro E

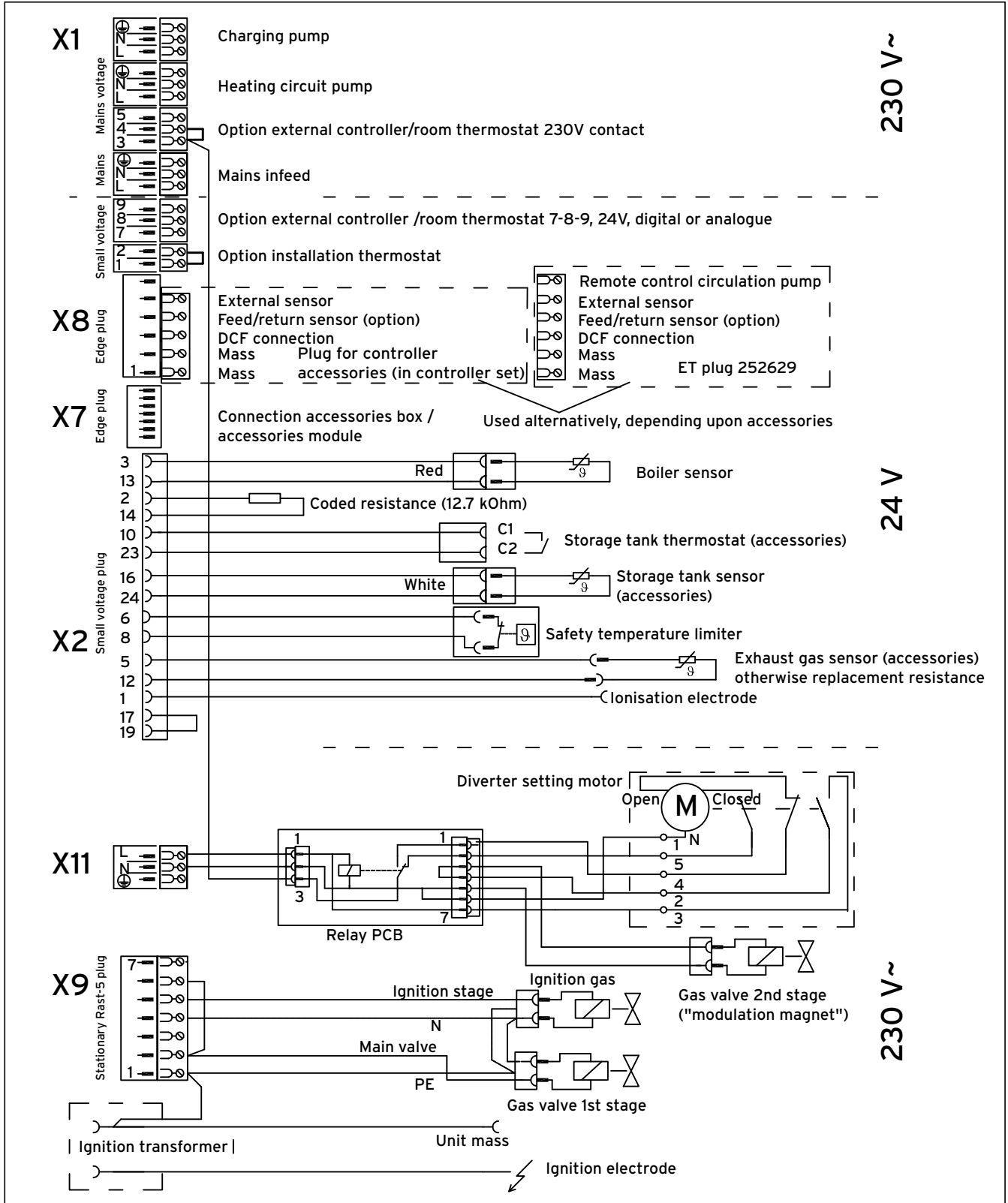

Fig. 5.3 Electrical connections atmoCRAFT up to 115 kW



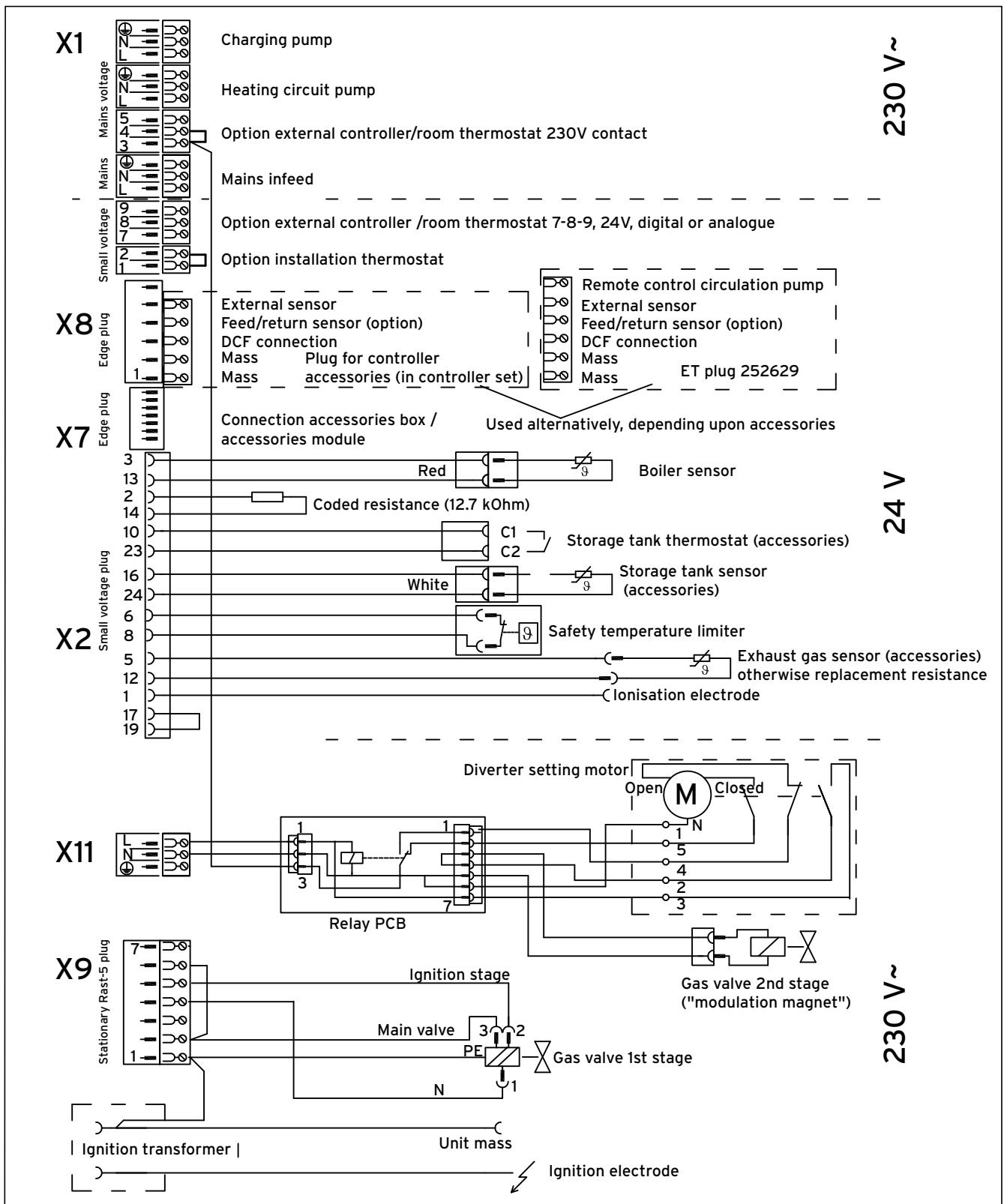

Fig. 5.4 Electrical connections atmoCRAFT above 130 kW

## 5 Installation

### 5.4.5 Connection of external accessories and control units

When connecting accessories, the existing bridge on the relevant plug must be removed.

Take especial care that the bridge is removed when incorporating an installation thermostat.

Controller	Connection
VRC 410s (1-circuit controller)	Insert into the operating aperture
VRC 420s (2-circuit controller)	Operating component: Insert into the operating aperture mixer module: electronic box ProE plug
auroMATIC 620	Terminal X1/7-8-9
calorMATIC 630	Terminal X1/7-8-9
VRT 40	Electronics box ProE plug
VRT 390	Terminal X1/7-8-9
VRT 320	Terminal X1/7-8-9
VRT 330	Terminal X1/7-8-9
VRT 340f	Receiver Insert into the operating aperture
VR 30/2	Plug X6/telephone jack (next to X2)
VR 80	to eBUS of controller calorMATIC 630 or auroMATIC 620
VR 90	
Mixer module VR 60	

**Table 5.1 Overview of the controllers which can be used**

Accessories and external installation components	Connection
External sensor VRC-DCF (from control set 410/420, see above)	Electronic box plug socket X 8
Maximum thermostat	Electronic box ProE plug "Installation thermostat"
Control fume extraction hood <b>and</b> Control external gas solenoid valve <b>and</b> Fault signal display <b>and</b> External heating pump <b>and</b> Control circulation pump <b>and</b> Control of an external exhaust gas diverter	The accessories are and ancillary connection box which contains the functions referred to. It is connected to the control box for control of the components: plug socket X 7
Control of external solenoid valve <b>or</b> Operating and fault signal display <b>or</b> Control external heating pump <b>or</b> Control circulation pump	The accessories can be used for <b>two</b> of the functions referred to - the setting of the required function is undertaken on the accessories. It is connected to the control box for control of the components: plug socket X 7
Flue gas sensor	Plugs are incorporated in the wiring harness, connection instead of standard replacement resistance fitted
Gas pressure monitor	Connection to ProE plug: Installation thermostat, plug socket X 1

**Table 5.2 Accessories and external installation components**



#### Note!

**For the gas pressure monitor, several switches having safety functions can be connected to the small voltage input of the installation thermostat (in series).**

The water shortage safety device, external controllers and similar items must be connected via potential-free contacts.

The controllers shown in Table 5.1 can be used for the control of the Vaillant atmoCRAFT and the heating system. The installation should be undertaken in accordance with the individual operating instruction manuals.

#### 5.4.6 Connecting external sensors, control units (accessories)

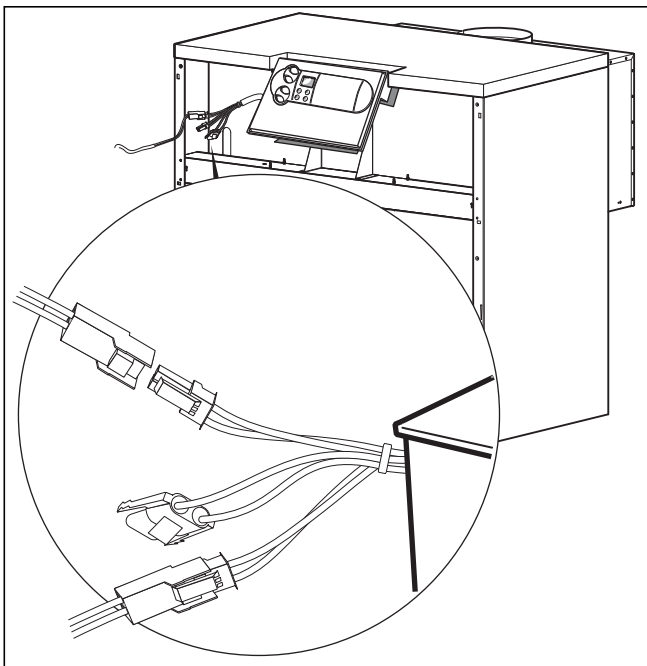

Fig. 5.5 Connecting the sensors

- Push the sensor for water storage tank onto the plug (white plug) on the sensor wiring harness.
- Connect the outer sensor to the edge plug X8 (when using a VRC 410 or 420).
- Connect the water shortage safety device or GDW potential-free to the "installation thermostat" (Pro E) and the exhaust gas diverter to the accessories.

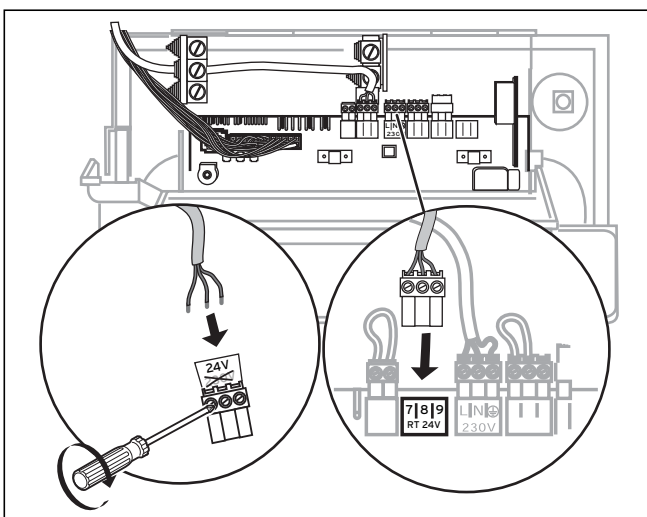

Fig. 5.6 Connecting controller to 7-8-9

#### Connectable accessories with Pro E system

Information concerning the electrical connection of the following accessories can be taken from the individual accessories instructions:

- Hot water storage tank
- Heating pump for the pipe groups
- Controllers

## 6 Start-up

Initial start-up and operation of the appliance, and instruction for the user, must be performed by a heating engineer.

For subsequent start-up/operation, see section 4.3 of the operating manual.

**Caution!**  
Before start-up, and after inspection, maintenance and repair work, the gas unit must be checked for leaks!

### 6.1 Filling the installation

#### 6.1.1 Water preparation in heating installations

Requirements for the quality of the filling and top-up water in accordance with VDI-2035:

Heat generators with output up to 100 kW:

Water having a carbon hardness of up to 3.0 mol/m<sup>3</sup> (16.8° dH) can be used for filling.

In the case of hard water, to avoid the build-up of deposits, hardness complexing or softening must be performed (see VDI 2035; Section 8.1.1 and 8.1.2 (**only in Germany**)).

Heating water (circulating water):

In the case of open heating systems with two safety lines, in which the heating water circulates through the expansion vessel, one must add oxygen-binding substances (VDI 2035, Section 8.2.2 for the German market and Ö-Standard H 5195), whereby an adequate excess in the return line is ensured by regular monitoring.

In the case of all other installations of this group measures for monitoring the composition of the heating water are not required.

**Caution!**  
In order to avoid operating faults caused by calcium deposits, on open installations in accordance with DIN 4751, Sheet 1 and in the case of a total hardness of the filling and top-up water in excess of 3 mol/m<sup>3</sup> (16.8° dH), water softening is to be recommended. The corresponding instructions for use provided by the individual manufacturers of these softening agents are to be observed.



### Caution!

**Do not add frost or corrosion preventative to the heating water!**

**If frost or corrosion preventative is added to the heating water this can cause changes in the seals and can cause noises to be created during the heating process.**

**Vaillant assumes no liability for this and such consequential damages.**

**Please inform the user of the procedure for frost protection.**

**If the heating water hardness is above 3,6 mol/m<sup>3</sup> (20 °dH) it should be softened. To do this you can use the ion-exchanger, Vaillant spare part number 990 349. Please observe the enclosed operating instructions.**

### 6.1.2 Preparing for operation

Proceed as follows to prepare the installation for operation:

- Fill the heating system to the required water level (at least 1.0 bar in closed systems) and bleed the air.
- Open the gas-cock in the gas line.
- Turn the main switch on.
- Check the gas connection pressure.
- Check the set gas volume.
- Perform an exhaust gas loss measurement to set the optimum combustion technology efficiency.
- If an indirectly heated hot water storage tank is incorporated, start it up. Observe the relevant installation and operating instructions.
- Check all the control, regulation and monitoring devices for correct operation and correct adjustment.
- Make the customer acquainted with the operation of the unit and hand over the instruction manual associated with the unit for suitable storage.
- Recommend a maintenance contract to the customer.

## 6.2 Checking the gas setting

### 6.2.1 Default setting

The boilers are set in the factory for natural gas 2E/2H (G20 - 20 mbar; Wobbe value 15.0 kWh/m<sup>3</sup>). Burner setting for natural gas 2E and 2H is not required. The gas pressure regulator on the gas fitting is sealed.



### Caution!

**Before start-up of the unit compare the details concerning the set type of gas on the identification plate with the type of gas supply and gas family at the installation site.**

If the unit version does **not** correspond to the local **gas family**:

- The boiler must be changed over to the relevant gas family before start-up.

The changeover must only be carried out by a heating engineer using the original changeover sets available from the factory to accommodate a different gas family. Observe the changeover instructions included with the changeover set.

### 6.2.2 Checking the connection pressure (gas flow pressure)

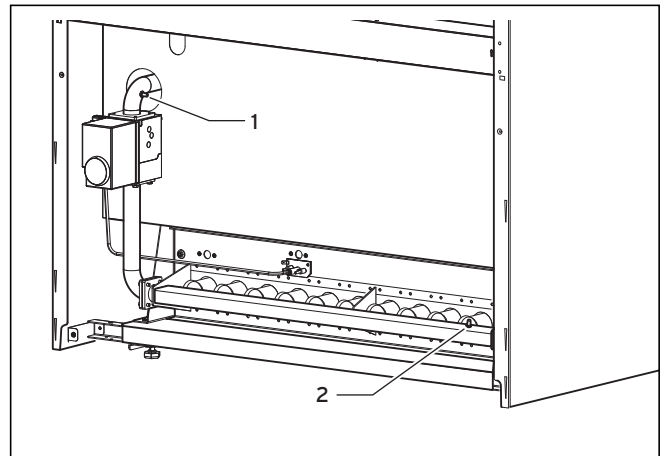

**Fig. 6.1 Connection pressure measuring connection**

Proceed as follows to check the connection pressure:

- Turn the boiler off.
- Close the gas-cock in the main gas infeed line to the boiler.
- Remove the screw on the connection pressure measuring connection (1) and connect a suitable pressure gauge.
- Start the boiler up in accordance with Chapter 6.
- Measure the connection flow pressure on the pressure gauge.

### The permissible range for the connection flow pressure is:

- 17.0 to 25.0 mbar - 2nd gas family (natural gases)
- 35.0 to 45.0 mbar - 3rd gas family (liquid gases)



#### Caution!

**If the connection pressure is outside the quoted range, the cause of the deviation should be found and the fault should be rectified. If no fault can be found no adjustments should be made and the boiler must not be started up and the responsible office of the gas supply company must be informed.**

- Turn the boiler off.
- Remove the pressure gauge and close the connection pressure measuring connection (1) with the sealing screw.

### 6.2.3 Setting the gas in accordance with the nozzle pressure method

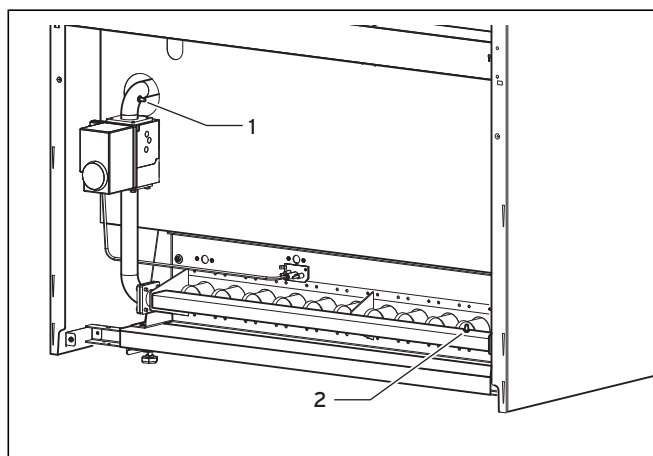

Fig. 6.2 Setting the nozzle pressure

Adjustment of the gas is only required after changing over to liquid gas (B/P). The cover cap over the setting screws must be removed for setting.

- Close the gas-cock in the main gas infeed line to the boiler.
- Release the closing screw in the nozzle pressure measuring connection (2), and connect a gas pressure measuring instrument with a resolution of 0.1 mbar to the nozzle pressure measuring on the gas distributor pipe.
- Open the gas shut-off cock again.
- Start the boiler up in accordance with Chapter 6.

### Setting the 1st. stage

- Change the boiler over via the diagnosis point d.00 to operation of the 1st stage.
- Adjust the nozzle pressure for part output 65% (1st stage) using a screwdriver on the slotted screw. Turning to the right (+) = nozzle pressure higher - more gas  
Turning to the left (-) = nozzle pressure lower - less gas

### Setting the 2nd. stage

- Change the boiler over, if necessary, via the diagnosis point d.00 to operation of the 2nd stage (full output).
- Compare the nozzle pressure with the value in the table in Chapter 6.2.4.



#### Note!

**Turn only up to the set burner pressure. Turning too far can lead to destruction of the pressure regulator.**

- First set the nozzle pressure for the nominal output (2nd. stage) using an open-ended spanner SW 8 on the hex nut (1). The setting screw (2) should be held stationary with a screwdriver whilst doing this. Turning to the right (+) = nozzle pressure higher - more gas  
Turning to the left (-) = nozzle pressure lower - less gas
- Turn the boiler off.
- Close the gas-cock in the main gas infeed line to the boiler.
- Remove the gas pressure measuring instrument.
- Turn the screw tightly in the nozzle pressure measuring connection on the gas distribution pipe.
- Change the boiler back over via the diagnosis point d.00 to automatic operation.

## 6 Start-up

### 6.2.4 Gas setting tables

Type of gas	Nozzle designation corresponds to the nozzle pressure diameter Ø in 1/100 mm	Nozzle pressure	
		Nominal output (2nd stage)	Partial output (1st. stage and starting gas pressure)
Natural gas 2E, 2H Ws = 15.0 kWh/m <sup>3</sup>	260	13.0	5.6
Propane 3P Ws = 22.5 kWh/m <sup>3</sup>	165	29	13.2

**Table 6.1 Nozzle pressure setting table**

Nozzle size and nozzle pressures for nominal output/partial output; Nozzle pressure in mbar at 15°C, 1013 mbar, dry.

	VK 654/9		VK 754/9		VK 854/9		VK 1054/9		VK 1154/9	
<b>Nominal output/partial output<sup>2)</sup></b>	65	42.2	75	48.7	85	55.2	105	68.2	115	74.7
<b>Gas flow <sup>1)</sup> [l/min] with natural gas 2E, 2H Ws = 15.0 kWh/m<sup>3</sup></b>	123	81	141	93	161	105	198	130	216	143
	VK 1304/9		VK 1504/9		VK 1654/9					
<b>Nominal output/partial output<sup>2)</sup></b>	130	84.5	150	97.5	165	107.5				
<b>Gas flow <sup>1)</sup> [l/min] with natural gas 2E, 2H Ws = 15.0 kWh/m<sup>3</sup></b>	248	161	283	186	313	205				

**Table 6.2 Gas flow setting table**

1) Gas flow in l/min at 15°C, 1013 mbar, dry

2) QNL in kW

(heat output; left column = nominal output, right column = partial output  
(65%))

### 6.2.5 Function check

To complete the gas setting it is necessary to carry out a function check as follows:

- Open the gas-cock and start up the boiler as shown in Chapter 6.
- Check the boiler and heating system for tightness.

**Caution!**  
Also make sure that all the gas pressure measuring nipples are tightly closed.

- Check the correct exhaust gas removal on the flow safety device.
- Check the over-ignition and consistent flame structure of the main burner.

### 6.2.6 Changeover from natural gas to liquid gas P

#### Changing the nozzles

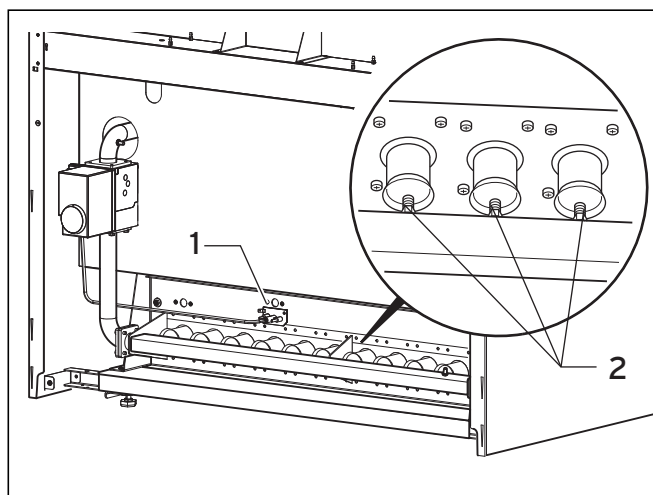

Fig. 6.3 Changing the nozzles

- Turn the boiler off.
- Replace the ignition burner nozzle for natural gas (1) by the nozzle for liquid gas P (1x24).
- Unscrew the burner nozzles for natural gas (2) and screw in the burner nozzles for liquid gas P (165) gas-tight.

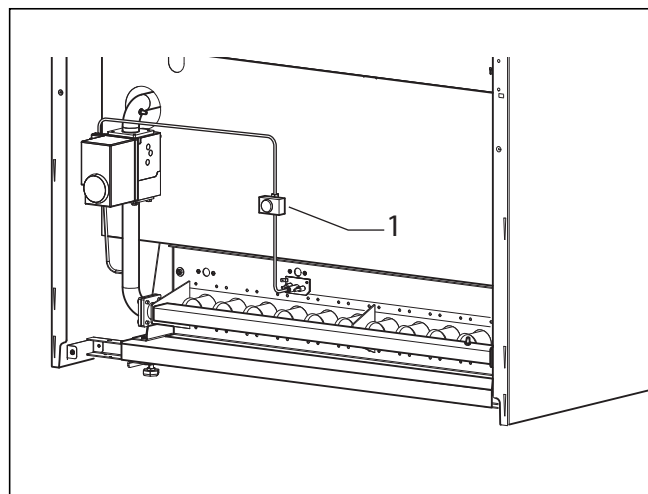

Fig. 6.4 Pipe connection with stop-cock

- Fit the pipe connection with stop-cock (1) onto the gas fitting.
- Connect the supplied cable connection in accordance with the circuit diagram.

#### Start-up and setting

**Caution!**  
Observe the instructions for gas connection in Chapter 6.2 in the installation instructions.

- Start the boiler up in accordance with Chapter 6 of the installation instructions.
- Re-set the nozzle pressure in accordance with Chapter 6.2.3 of the installation instructions.
- Check all the screwed connections which have been released and tightened again during the changeover for tightness using leak testing spray.
- Stick the enclosed sticker "changed over to liquid gas" onto the gas distributor pipe.

**Note!**  
Keep the components removed during the changeover and this fitting instruction for possible future refitting.

## 6 Start-up

### 6.2.7 Changeover from liquid gas P to natural gas

#### Changing the nozzles

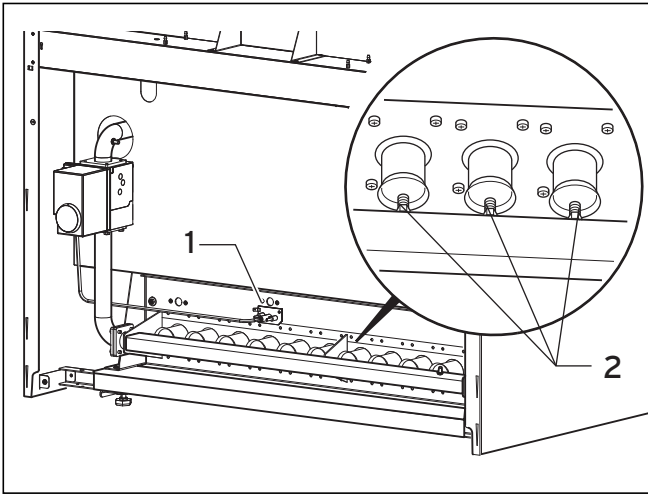

Fig. 6.5 Changing the nozzles

- Turn the boiler off.
- Replace the ignition burner nozzle (1x24) (1) by the nozzle for natural gas E(H) (2x27).
- Unscrew the burner nozzles for liquid gas P (165) (2) and screw in the burner nozzles for natural gas E(H) (260) gas-tight.

#### Start-up and setting

**Caution!** Observe the instructions for gas connection in Chapter 6.2 in the installation instructions.

- Start the boiler up in accordance with Chapter 6 of the installation instructions.
- Re-set the nozzle pressure in accordance with Chapter 6.2.3 of the installation instructions.
- Check all the screwed connections which have been released and tightened again during the changeover for tightness using leak testing spray.
- Remove the sticker "changed over to liquid gas" from the gas distributor pipe.

**Note!** Keep the components removed during the changeover and this fitting instruction for possible future refitting.

### 6.2.8 Checking the exhaust gas installation

**Note!** The position of the exhaust gas connection can be taken from the figure 4.22. Take particular care that the exhaust gas pipe runs upwards towards the chimney.

The checking of the exhaust gas installation for correct exhaust gas removal must be undertaken under the following operating conditions:

- The windows and doors in the installation room must be closed.
- The specified ventilation devices must not be closed off, obstructed or retracted.
- The recommended chimney draught must be at least 0.03 mbar and must not exceed 0.09 mbar.

**Note!** The lower the chimney draught within the permissible range, the higher is the combustion technology efficiency of the gas combustion location.

**Caution!** The lower value of the chimney draught must not be reduced further because of the requirement for correct exhaust gas removal. The upper value of the chimney draught must not be exceeded in order to achieve a gut degree of efficiency. At a chimney draught of less than 0.03 mbar or more than 0.09 mbar, the unit must not be started up.

**Note!** In the event of the chimney draught being more than 0.09 mbar or less than 0.03 mbar, consult the district chimney sweep (or smoke capture cleaner) for assistance.

- The exhaust gas loss measurement in accordance with BImSchV must also be performed under the above operating conditions.

### 6.3 Training the operator

The operator of the heating installation must be instructed in the handling and functions of his heating installation. The following measures need to be specially taken into account:

- Hand all instructions and installation papers over to the operator for storage. Tell the owner to keep the manuals nearby the unit.

**Caution!** When you have finished the installation, attach the sticker supplied (835 593) to the appliance in the user's language.

- Tell the owner about any measures taken to ensure the combustion air supply and flue gas extraction, making it very clear that they may not be altered.
- Explain to the user how to check the required water level/filling pressure of the plant as well as measures for refilling and bleeding the heating system if needed.



- Point out to the user the correct (economical) settings for temperatures, regulators and thermostat valves.
- Instruct the owner on the need for regular inspection and maintenance of the system.

Recommend a inspection/maintenance contract to the customer.

## 6.4 Vaillant warranty

Vaillant provide a full parts and labour warranty for this appliance.

The appliance must be installed by a suitably competent person in accordance with the Gas Safety (Installation and Use) Regulations 1998, and the manufacturer's instructions. In the UK 'CORGI' registered installers undertake the work in compliance with safe and satisfactory standards.

All unvented domestic hot water cylinders must be installed by a competent person to the prevailing building regulations at the time of installation (G3).

Terms and conditions apply to the warranty, details of which can be found on the warranty registration card included with this appliance.

Failure to install and commission this appliance in compliance with the manufacturer's instructions may invalidate the warranty (this does not affect the customer's statutory rights).

## 7 Adapting the appliance to the heating system

The atmoCRAFT units are fitted with a digital information and analysis system (DIA system).

### 7.1 Selection and setting the parameters

In the diagnosis mode you can change various parameters in order to match the boiler to the heating system.

In the Table 7.1 the diagnosis points shown are the only ones where you can make alterations. All the other diagnosis points are required for the diagnosis and fault rectification (see Chapter 8).

The display shows the relevant diagnosis information.

- Keep the buttons "i" and "+" depressed for approx. 5 seconds until "d.0" appears in the display.
- You can move backwards and forwards between the parameters by pushing the buttons "+" or "-".
- Push the button "i" in order to open the menu of the selected parameter.
- If necessary, use the "+" or "-" buttons to change the value (display flashes).
- Save the new value by holding down the "i" button for approx. 5 seconds until the display no longer flashes.

You can end the diagnosis mode as follows:

- Simultaneously push the buttons "i" and "+" or do not push any buttons for about 4 minutes.

The current heating flow temperature appears in the display again.

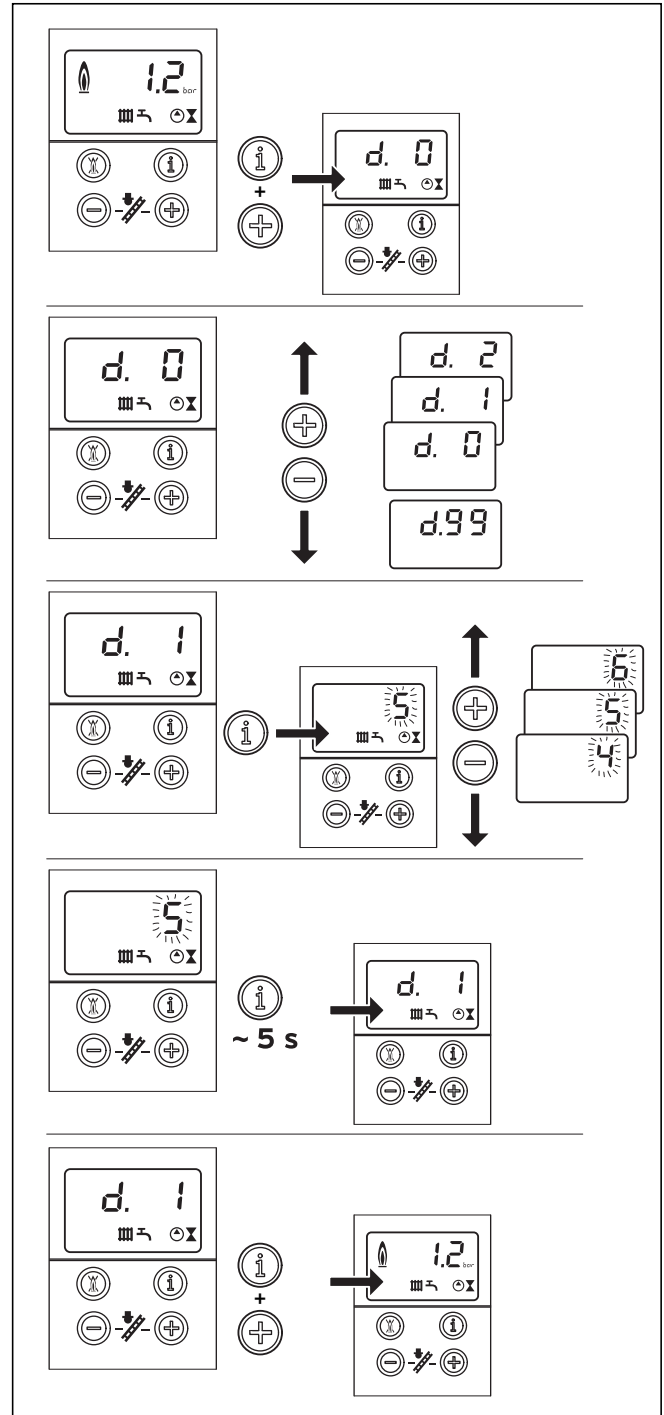



Fig. 7.1 Setting the parameters in the DIA system

## 7 Adapting the appliance to the heating system

### 7.2 Overview of the adjustable installation parameters

The following parameters can be adjusted to match the unit to the heating system and to the requirements of the customer:

 **Note!**  
In the last column you can enter your settings after you have set the installation-specific parameters.

Display	Meaning	Adjustable values	Factory setting	Installation-specific adjustment
d.00	Test operation on 1st burner stage for gas setting (only for 2-stage boilers)	0 - Normal operation (both stages) 1 - After start changes back to 1st stage 2 - Full capacity (2nd stage)	0	
d.01	Heating pump overrun Starts after ending of heat demand	5 - 60 min "- " for through flowing	5 mins	
d.02	Burner locking time Starts after ending of heating operation	2 - 60 min	2 min	
d.05	Supply temperature target value	Display in °C	-	
d.16	Changeover external pump/solar pump	2 = Normal mode	2	
d.46	External temperature correction value For correction of external heat effects on the sensor	- 10 ... 10 K	0 K	
d.50	Switch-off hysteresis of feed controller Switch-off temperature above the calculated target value	0 ... 10 K	6 K	
d.51	Switch-on hysteresis of feed controller Switch-on temperature below the calculated target value	0 ... 10 K	2 K	
d.71	Maximum feed temperature for heating operation	40 °C ... 85 °C	75 °C	
d.72	Pump overrun time after storage tank charging	0, 10, 20, ... 600 s	300 s	
d.75	Maximum storage tank charging time of a storage tank without its own controller	20, 21, 22 ... 90 min	30 min	
d.78	Feed target temperature in storage tank operation (Limiting of storage tank charging temperature)	60 °C ... 90 °C	90 °C	
d.84	Number of hours to the next maintenance or "Off" 0	0 ... 300 x 10 h or "- " (Off)	"-" (Off)	
d.85	Minimum feed target temperature	30 °C ... 50 °C	35 °C	

Table 7.1 Adjustable parameters of the DIA system

## 8 Inspection and maintenance

### 8.1 Notes for maintenance

Permanent operational readiness, safety, reliability and a long service life require inspections and maintenance work to be carried out regularly every year by a heating engineer.



**Danger!**

**Inspection, maintenance and repair work should only be undertaken by an approved heating installation company. Inspections / Maintenance work not carried out can result in damage to property and personal injury.**

Only genuine Vaillant spare parts may be used for inspections, maintenance and repair work to ensure the perfect long-term working order of all functions of your Vaillant appliance and to prevent the allowed series condition from being changed.

Any spare parts which might be required are listed in the relevant current spare parts catalogues. Information can be obtained from Vaillant Customer Service Centres.

### 8.2 Safety instructions

Always perform the following steps prior to inspection work:

- Switch off the mains switch.
- Close the gas shut-off valve.
- Close the heating feed and return.



**Danger!**

**Risk of fatal electric shock from touching live connections! The supply terminals in the terminal box of the device are under voltage even if the mains switch is off. Protect the switch box from water splashes. Before working on the appliance, turn off the power supply and secure against restart!**

Always perform the following steps after completing any inspection tasks:

- Close the heating feed and return.
- If necessary, refill the device with hot water up to a pressure of approx 1.5 bar and evacuate the heating system.
- Open the gas shut-off cock.
- Turn on the power supply and the main switch.
- Check the appliance for gas and water leaks.
- If necessary, refill and re-bleed the heating system.



**Note!**

**If it is necessary to keep the main switch on for certain inspection and maintenance, this is indicated in the description of the maintenance task.**

### 8.3 Overview of the maintenance tasks

The following steps must be taken during maintenance of the unit:

No.	Step	to be performed:	
		1 x annually	as required
1	Isolate unit from electrical mains and close gas-cock	X	
2	Close maintenance cocks; Release pressure on heating and hot water circuits, or drain if necessary		X
3	Check the safety temperature limiter STL	X	
4	Automatic gas firing system	X	
5	Check gas pressure monitor (option)	X	
6	Check the unit for leaks	X	
7	Visual check of exhaust gas system, heat exchanger, burners, exhaust gas diverter of flow safety device	X	
8	Checking the gas setting	X	
9	Perform exhaust gas measurements	X	
10	Check the function of the exhaust gas diverter	X	
11	Cleaning the burner	X	
12	Change the seals	X	
13	Cleaning the heat exchanger		X
14	Checking the control and safety devices	X	
15	Checking the gas setting	X	
16	Perform exhaust gas measurements	X	
17	Checking the control devices, re-setting if required	X	
18	Recording the maintenance tasks and exhaust gas measurements made	X	

**Table 8.1 Maintenance steps**

## 8 Inspection and maintenance

### 8.3.1 Checking the safety temperature limiter



Abb. 8.1 Release button, button fault reset

#### Key

- 1 STL release button with cover cap
- 2 Button fault reset

- Switch on the mains switch.
- Turn the heating circuit off.
- Set the unit to maximum feed temperature and heat the unit up to switch-off by the controller.
- After waiting for two minutes (temperature balancing) start the test programme **P.5**.  
By starting the test programme **P.5** the boiler remains in operation until the safety temperature limiter responds.  
The test programme **P.5** is called up by switching "Mains on" whilst simultaneously holding the button "+" down for 5 seconds. By pushing the "Info" button the test programme is started and the boiler is started for the STL test.

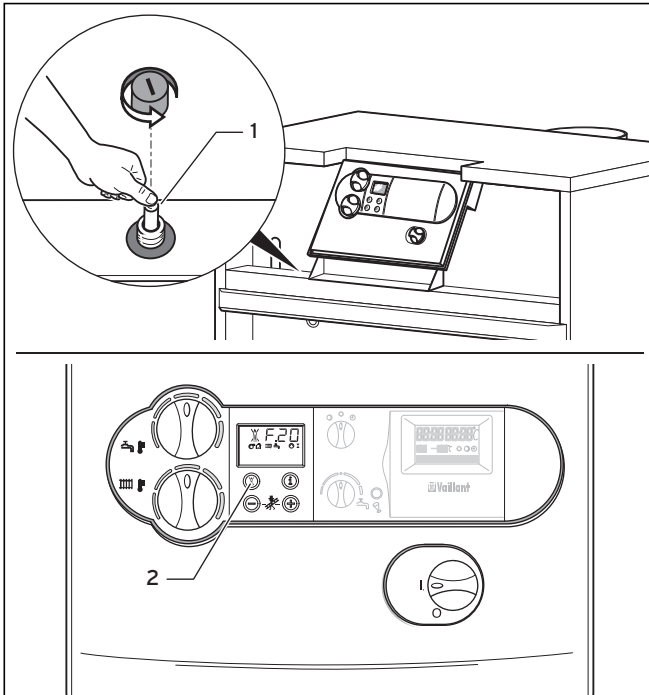

#### Note!

**The internal heating pump is not switched off for control technological reasons. The isolation units in the heating circuits should therefore remain closed during the STL test.**

- The boiler must switch off at 110 °C.
- Unlock after the boiler has cooled down (see Section 9.3).



#### Note!

**The test programme is automatically exited after 15 minutes. The test must be performed within this time period.**

### 8.3.2 Automatic gas firing system

- Remove the plug of the ionisation cable during operation.

The burner flames must go out immediately.

The automatic gas combustion unit starts again after approx. 30 seconds. After the third unsuccessful ignition attempt the automatic gas combustion unit switches to fault. The error message "**F.29**" appears in the display.

- Re-insert the plug of the ionisation cable.

The boiler can be unlocked after approx. five seconds (see Section 9.3).

### 8.3.3 Sealing

- Check the unit, the exhaust gas installation and the water lines for leaks.

### 8.3.4 Checking the combustion air and exhaust air

- Perform a visual check of the combustion air and exhaust air lines.
- Check that the existing combustion air and exhaust air grids are clean and in order.
- Check that the existing combustion air and exhaust air ducts are free and not blocked.

### 8.3.5 Checking the exhaust gas installation

Perform a visual check of the following components:

- Exhaust gas installation
- Heat exchanger
- Burner
- Exhaust gas diverter for flow safety device (1st stage = exhaust gas diverter closed, 2nd. stage = exhaust gas diverter open)

### 8.3.6 Checking the gas setting

- Check the gas setting by comparison of the gas flow on the gas meter with the value in the table values in the gas through-flow table (see Table 6.2 gas through-flow setting table).

### 8.3.7 Exhaust gas losses and combustion quality

In order to determine the exhaust gas losses,  $t_{he}$  CO<sub>2</sub> content in the exhaust gas, the exhaust gas temperature and the room air temperature must be measured.

Modern electronic exhaust gas analysis instruments allow several measuring parameters to be determined or calculated at the same time.

- CO<sub>2</sub> content (or O<sub>2</sub> content)
- Exhaust temperature
- Room air temperature
- CO content
- Chimney draught
- Exhaust gas losses (automatically calculated)
- Perform the required measurements.

## 8.4 Maintenance tasks

### 8.4.1 Cleaning the burner



**Caution!**

If possible, do not use any chemical cleaning agents, otherwise deposits could build up on the monitoring and ignition electrodes. The unit may switch to fault condition.

If you do use chemical cleaning agents, make sure that the electrodes are thoroughly cleaned afterwards.

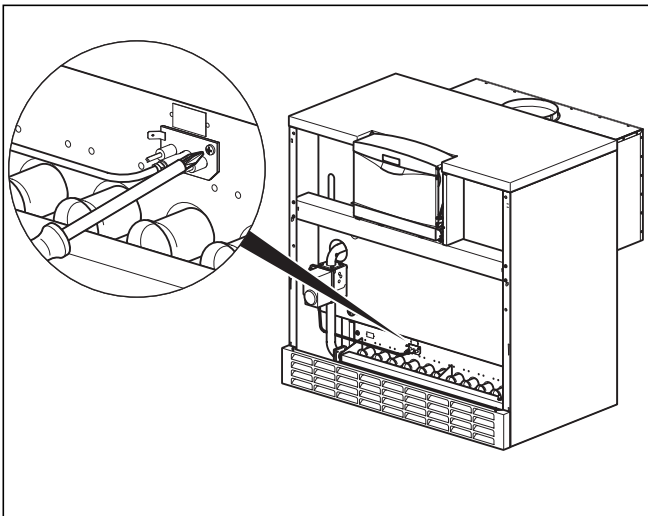

**Fig. 8.2 Dismantling the ignition electrode**

For maintenance of the burner and the heat exchanger, first remove the burner. Proceed as follows:

- Remove the front cover.
- Release the connection screws on the gas inlet line.



**Caution!**

Always replace the seals by new original ones when assembling.

- Remove the ignition cable connection from the electronic box.
- Remove the earthing cable connection.
- Release the nuts on the burner bracket.
- Pull out the plug from the gas fitting.
- Separate the ionisation cable at the plug connection.

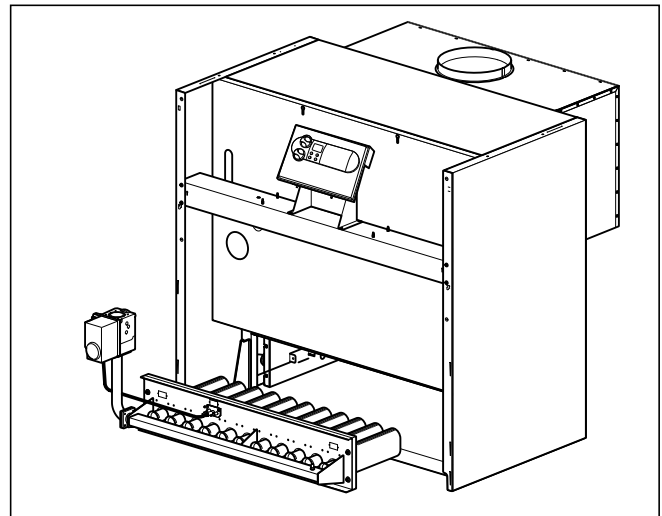

**Fig. 8.3 Burner removal**

- Pull the burner out.

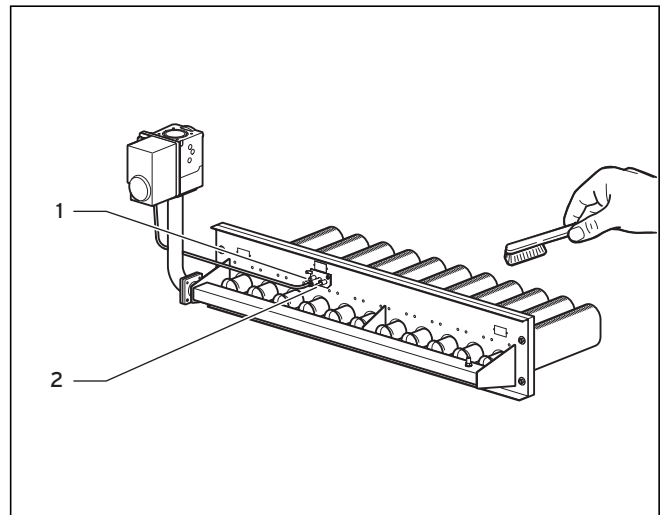

**Fig. 8.4 Cleaning the burner**

- Clean the burner lances in the area of primary air intake and the outlet openings using a paint brush and a brush (not a wire brush!).
- Clean the main burner nozzles, the ignition electrode (1), the monitoring electrode (2) and the ignition burner.
- Thoroughly clean the baseplate.

## 8 Inspection and maintenance

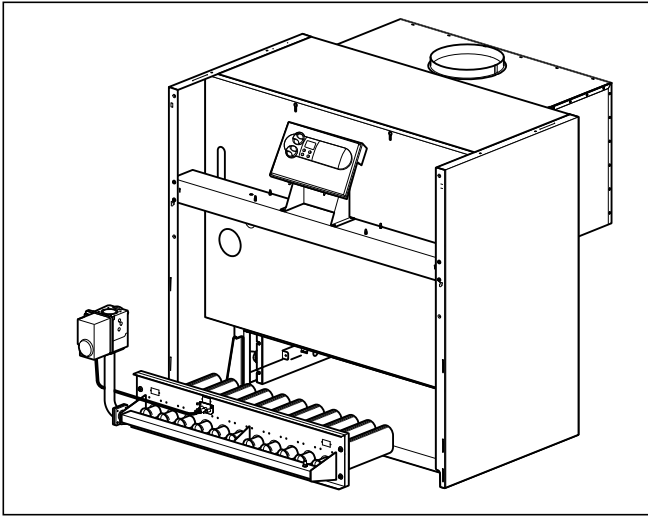

Fig. 8.5 Fitting the burner

If it is necessary to also clean the heat exchanger, proceed as per Section 8.4.2. Cleaning the heat exchanger.

Otherwise re-fit the burner.

Proceed as follows:

- Replace all the seals with original new ones.
- Slide the burner back in.
- Connect the gas connection pipe.
- Replace all the electrical connections previously removed.
  - Perform a function test on the control and safety devices (see Section 8.3).
  - Check the boiler, exhaust gas installation and gas connection for tightness.
  - Fit the cladding.

### 8.4.2 Cleaning the heat exchanger

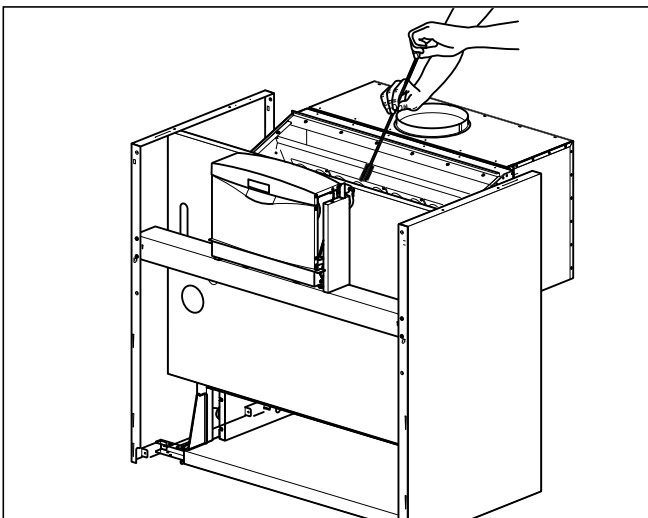

Fig. 8.6 Brushing the exhaust gas ducts

- Remove the cladding and the insulation.
  - Remove the burner as described in Section 8.4.1
- Cleaning the burner.
- Clean the exhaust gas ducts (1) thoroughly using the cleaning brush supplied (2). You can access the exhaust gas ducts through the cleaning aperture in the exhaust gas manifold.
  - Re-fit the burner again (see Section 8.4.1).



#### Caution!

**After cleaning, the gas and exhaust gas routes must be checked for tightness.**

- **Perform a function test on the control and safety devices (see Section 8.3).**

### 8.4.3 Checking the gas setting

- Check the gas setting by comparison of the gas flow on the gas meter with the values in Table 6.2.

### 8.4.4 Performing the exhaust gas measurement and checking the combustion quality

In order to determine the exhaust gas losses,  $t_{he}$  CO<sub>2</sub> content in the exhaust gas, the exhaust gas temperature and the room air temperature must be measured.

Modern electronic exhaust gas analysis instruments allow several measuring parameters to be determined or calculated at the same time.

- CO<sub>2</sub> content (or O<sub>2</sub> content)
  - Exhaust temperature
  - Room air temperature
  - CO content
  - Chimney draught
  - Exhaust gas losses (automatically calculated)
- Perform the required measurements.

## 9 Troubleshooting

### 9.1 Error codes

For fault finding and fault rectification, the fault signal facility of the DIA system is normally adequate. The following fault codes are shown in the display and help with the localisation and rectification of a fault.

Code	Meaning	Cause
F.00	Interruption - forward flow NTC	NTC-connector not plugged in or loose, NTC defective or earth connection loose/not plugged in
F.05	Interruption - exhaust gas sensor (accessories)	Exhaust gas sensor faulty or not plugged in Replacement resistance not properly plugged in
F.10	Short circuit feed sensor	NTC plug faulty, mass short/short circuit in wiring harness
F.13	Short circuit storage tank sensor	NTC plug faulty, mass short/short circuit in wiring harness
F.15	Short circuit exhaust gas sensor (accessories)	Sensor faulty, short circuit in wiring harness, mass short
F.20	Safety temperature limiter has responded Manual release on the STL	Feed NTC not thermally connected in Unit will not switch off
F.27	External light: ionisation signal reports a flame in spite of gas valve being turned off	Gas solenoid valve defective, flame detector defective
F.28	Fault in unit start-up: Ignition attempts during start-up unsuccessful, the unit does not go into operation	Faults in the gas supply such as: - Gas meter or gas pressure monitor faulty - Air in gas - Gas flow pressure too low Fire protection cock has responded Fault in gas fitting: Main gas magnet or Operator faulty Incorrect gas setting
F.29	Fault in continuous operation: Flame goes off during operation and subsequent ignition attempts failed	Gas supply temporarily stopped, ignition transformer has spark failure, faulty earthing of appliance
F.36	Exhaust gas escape sensed by exhaust gas sensor	Exhaust gas route blocked or chimney draught too low (e.g. chimney too cold)(if an exhaust gas sensor is fitted)
F.42	No valid value for appliance variant	Short-circuit in cable harness
F.43	No valid value for appliance variant	Interruption in cable harness
F.60- 67	Irreversible electronics fault	Defective electronics
F.61	Electronics faulty or gas valve not connected correctly	Coil faulty, plug loose
F.64	Irreversible electronics fault	Electronics is faulty or short-circuit on feed sensor

**Table 9.1 Error codes**

If you need to make measurements on the unit electronics during fault rectification, observe the following instructions.



**Danger!**

**Danger of death by electrocution!**  
**If the switchgear box is swung down and the back wall of the switchgear box is completely removed, the mains transformer lies directly in the easily accessible range of the hands. For this reason, all measurements on the electronics must only be undertaken with the switchgear box back-wall in position. Just open the cover over the connection area, all measuring points are accessible from here.**

**Error memory**

The last ten errors are saved in the appliance error memory.

- Press the “i” and “-” buttons simultaneously.
  - Scroll back in the error memory with the “+” button. You can exit the error memory display as follows:
  - Press the “i” button or
  - Do not press any button for about 4 minutes.
- The current heating flow temperature appears in the display again.

## 9 Troubleshooting

### 9.2 Resetting the interlock after switch-off by the safety temperature limiter (STL)

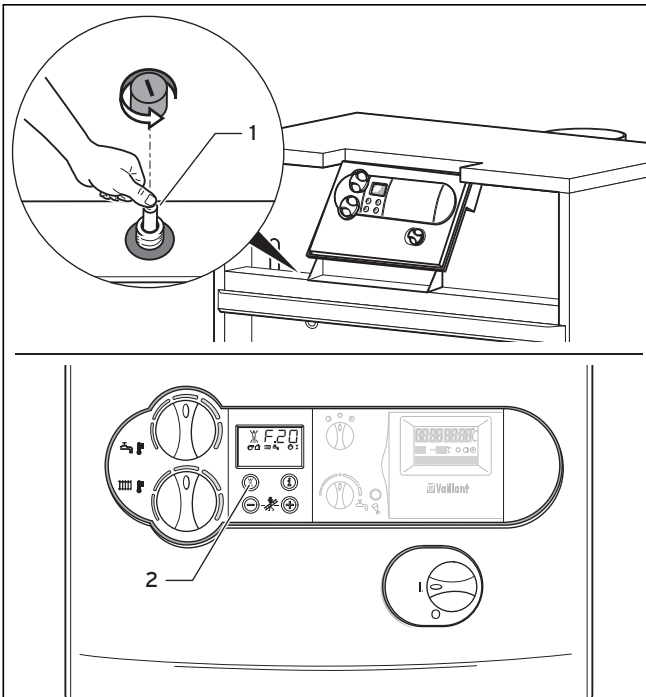

**Fig. 9.1** Resetting the interlock after switch-off by the STL

If the fault code “**F.20**” is displayed, the safety temperature limiter (STL) has automatically switched the boiler off because the temperature is too high. Proceed as follows to reset it:

- Remove the front cover.
- Remove interlock on STL by pressing the pin (1).
- Reset the electronics by pushing the “Fault reset” button (2).

Every time the STL responds you need to perform a fault-finding exercise and remove the fault.

### 9.3 Status codes

The status codes that you can see on the display of the DIA provide information about the current operating condition of the appliance.

If several operating conditions arise at the same time, the most important status code is always displayed.

The display of the status codes can be viewed as follows:

- Press the “i” button.  
The display shows the status code, e.g. **S.04** for “Burner mode - Heating”.

The display of the status codes can be ended as follows:

- Press the “i” button or
- Do not press any button for about 4 minutes.  
The current heating flow temperature appears in the display again.

Display	Meaning
	<b>Displays during heating operation</b>
S.00	No heat required
S.02	Heating pump supply
S.03	Heating ignition
S.04	Heating burner on
S.07	Heating pump run-out
S.08	Burner lock after heating mode
	<b>Displays during storage tank charging</b>
Page 20	Storage cycle mode active
S.23	Storage tank charging ignition
S.24	Storage tank charging burner
S.27	Storage tank charging pump overrun
S.28	Burner blockage after storage tank charging
	<b>Displays of system conditions</b>
S.30	No heat requirement controller from 2-point controller
S.31	Summer mode active
S.34	Heating frost protection active
S.36	No heat requirement controller from continuous controller
S.39	Switch on terminal “Installation thermostat” has interrupted
S.42	Exhaust gas diverter contact on accessories open
S.51	Unit has sensed exhaust gas escape and is within the 55 second tolerance time period
S.52	Unit is within the 20 minute waiting period because of exhaust gas escape (atmospheric units)

**Table 9.2** Status codes

### 9.4 Diagnosis codes

In the diagnosis mode, you can change certain parameters or display more information see Table 9.3. The parameters which can be changed are in bold type. The setting of these parameters is also described in Chapter 7.1.

- Press the “i” and “+” buttons simultaneously.  
The display shows “d.00”.

- Scroll to the desired diagnosis number with the “+” or “-” buttons.
- Press the “i” button.  
The display shows the relevant diagnosis information.

- If necessary, use the “+” or “-” buttons to change the value (display flashes).
- Save the new value by holding down the “i” button for approx. 5 seconds until the display no longer flashes.

You can end the diagnosis mode as follows:

- Press the “i” and “+” buttons simultaneously or
- Do not press any button for about 4 minutes.

The current heating flow temperature appears in the display again.



Display	Meaning	Display value/adjustable value
<b>d.00</b>	Test operation on 1st burner stage for gas setting (only for 2-stage boilers)	0 = Normal operation (both stages) 1 = After starting switching back to the 1st stage 2 = Full output (2nd stage)
d.01	Heating pump overrun Starts after ending of heat demand	5 .. 60 min, "-" for continuous
<b>d.02</b>	Burner locking time Starts after ending of heat demand	2 .. 60 min
d.04	Measured value of storage temperature	in °C
d.05	Flow temperature target value	in °C
d.07	Display of storage tank target temperature	Adjustable from 40 - 70 °C (15 °C -signifies frost protection)
d.08	Room thermostat at terminal 3-4	1 = closed (heat mode) 0 = opened (no heat mode)
d.09	Supply target temperature from external controller to terminal 7-8-9	in °C (continuous control)
d.10	Heating pump	1 = on, 0 = off
d.11	Heating pump (via accessories)	1 = on, 0 = off
d.12	Cylinder charging pump	1 = on, 0 = off
d.13	Circulation pump	1 = on, 0 = off
d.16	Changeover external pump/solar pump	2 = Normal mode
d.22	Demand for storage tank charging via contact C1/C2	1 = yes, 0 = no
d.23	Operating mode Summer /winter function	1 = Heating on, 0 = Heating off
d.25	Release for storage tank charging from external controller	1 = yes, 0 = no
d.30	Heat demand from electronics	1 = yes, 0 = no
d.40	Feed temperature actual value	in °C
<b>d.46</b>	External temperature correction value	Setting range -10 ... +10 (factory setting: 0)
d.47	External temperature actual value	in °C
d.48	Exhaust gas sensor actual temperature value	in °C
<b>d.50</b>	Switch-off hysteresis of feed controller	Setting range 0 ... +10 (factory setting: 6)
<b>d.51</b>	Switch-on hysteresis of feed controller	Setting range 0 ... +10 (factory setting: -2)
d.60	Number of temperature limiting shutdowns	Amount
d.61	Number of fuel automatic system faults = Number of successful ignitions in the last attempt	Amount
d.68	Number of unsuccessful ignitions in the first attempt	Amount
d.69	Number of unsuccessful ignitions in the second attempt	Amount
<b>d.71</b>	Maximum heating feed temperature	Setting range 50 °C ... 87 °C (factory setting: 82 °C)
<b>d.72</b>	Pump overrun time storage tank charging	Setting range 0, 10, 20, ... 600 s (factory setting: 180 s)
<b>d.75</b>	Maximum charging time for a storage without own controller	Setting range 75 °C ... 90 °C (factory setting: 85 °C)
d.76	Appliance variants	15
<b>d.78</b>	Limiting of storage tank charging temperature	Setting range 75 °C ... 90 °C (factory setting: 85 °C)
d.79	Legionella protection (display only with controller connected)	1 = active, 0 = off
d.80	Number of heating operating hours <sup>1)</sup>	u xx 1.000 + xxx (in h)
d.81	Number of storage tank operating hours <sup>1)</sup>	u xx 1.000 + xxx (in h)
d.82	Number of burner starts heating <sup>1)</sup>	u xx 100.000 + xxx 100 (number)
d.83	Number of burner starts hot water operation <sup>1)</sup>	u xx 100.000 + xxx 100 (number)
<b>d.84</b>	Number of hours until the next maintenance	Setting range 0 ... 300 and "-" (factory setting: "-")
<b>d.85</b>	Minimum feed target temperature	Setting range 0 °C ... 60 °C
d.90	Digital controller	1 = detected, 0 = not detected
d.91	Status DCF	0 = no reception, 1 = reception, 2 = synchronised, 3 = valid

**Table 9.3 Diagnosis codes**

1) The first two displayed numbers must be multiplied by a factor of 1000 (or 100,000). By pushing the "i" button again the hours (or the number x 100) are displayed in three figures.

## 10 Vaillant service

### 11 Recycling and disposal

#### 10 Vaillant Service

To ensure efficient and reliable operation of your boiler it is recommended that regular servicing is carried out by your service provider.

Vaillant Applied System Sales  
Vaillant Ltd., Unit D1 Lowfields Business Park, Elland.  
West Yorkshire. HX5 9DG

Training  
Telephone 01634 292370  
Fax 01634 292354  
email training@vaillant.co.uk

Commercial Service  
Telephone 0870 850 3072  
Mon - Fri 8.30 - 17.30  
Fax 01773 525 946  
email aftersales@vaillant.co.uk

#### 11 Recycling and disposal

Recycling and disposal are already taken into account during the development of all Vaillant products. Vaillant's standards lay down strict requirements. The recyclability, demountability and separability of materials and components are taken into account for the selection of materials in the same way as environmental hazards and health risks during recycling and the disposal of unavoidable remains of unusable residue.

##### 11.1 Appliance

The Vaillant boiler consists of 92% metallic materials which can be melted down again at iron and steel works and therefore can be recycled almost any number of times. The EPS (Styropor)<sup>®</sup> EPP used to isolate the storage and other components is recyclable and CFC-free. The plastic materials used are labelled, and thus are already prepared for sorting for subsequent recycling.

##### 11.2 Packaging

Vaillant has reduced the transport packaging of the appliances to a minimum. The strict selection of packaging materials is based on their recyclability. The high-quality cardboard types are secondary raw materials which have been in demand in the cardboard and paper industry for a long time. EPS and EPP (polystyrene)<sup>®</sup> are used to protect the products during transport. EPS is recyclable and CFC-free. Even the films and tightening bands are made of recyclable plastic.

## 12 Technical data

Technical data	Unit	VK 654/9	VK 754/9	VK 854/9	VK 1054/9	VK 1154/9	VK 1304/9	VK 1504/9	VK 1654/9
Nominal heat output	kW	65	75	85	105	115	130	150	165
Nominal heat loading	kW	70.7	81.5	92.4	114	125	141.3	163	179.3
Minimum heat output	kW	42.2	48.7	55.2	68.2	74.7	84.5	97.5	107.5
Minimum thermal load	kW	46	53	60	74.1	81.3	91.8	106	116.3
Number of elements		8	9	10	12	13	15	17	19
Required feed pressure <sup>1)</sup>	Pa	3	3	3	3	3	3	3	3
Exhaust gas temperature only at nominal output <sup>1)</sup>	°C	115	115	115	115	118	120	123	123
Exhaust gas temperature at minimum output <sup>1)</sup>	°C	80	80	80	80	80	80	80	80
Exhaust gas mass flow at nominal output <sup>1)</sup>	kg/h	162	180	205	252	270	317	360	403
Exhaust gas mass flow at minimum output <sup>1)</sup>	kg/h	144	166	187	234	256	288	335	367
CO <sub>2</sub> - content at nominal output <sup>1)</sup>	%	6.5	6.5	6.5	6.5	6.6	6.6	6.6	6.6
CO <sub>2</sub> - content at minimum output <sup>1)</sup>	%	4.5	4.5	4.5	4.5	4.5	4.5	4.5	4.5
Water side resistance at $\Delta T = 20$ K	mbar	18	25	32	44	46	52	60	68
Water side resistance at $\Delta T = 10$ K	mbar	76	110	130	200	180	220	250	280
Permissible operating overpressure	bar	3	3	3	3	3	3	3	3
Nominal efficiency at 75/60 °C)	%	92.5	92.5	92.5	92.5	92.5	92.5	92.5	92.5
Feed temperature adjustable	°C	35 - 83	35 - 83	35 - 83	35 - 83	35 - 83	35 - 83	35 - 83	35 - 83
Connection values:									
Natural gas E, H <sub>i</sub> = 9.5 kWh/m <sup>3</sup>	m <sup>3</sup> /h	7.4	8.5	9.7	11.9	13	14.9	17	18.8
Liquid gas P, H <sub>i</sub> = 12,8 kWh/kg <sup>2)</sup>	kg/h	5.5	6.3	7.2	8.8	9.7	11	12.7	14
Gas connection pressure:									
Gas connection pressure natural gas	mbar	20	20	20	20	20	20	20	20
Gas connection pressure liquid gas <sup>2)</sup>	mbar	37	37	37	37	37	37	37	37
Electrical connection	V/Hz	230/50	230/50	230/50	230/50	230/50	230/50	230/50	230/50
Electrical power consumption, max.	W	< 60	< 60	< 60	< 60	< 60	< 60	< 60	< 60
Feed and return connection	R <sub>p</sub>	R 1 1/2"	R 1 1/2"	R 1 1/2"	R 1 1/2"	R 1 1/2"	R 1 1/2"	R 1 1/2"	R 1 1/2"
Gas connection	R <sub>p</sub>	R 1"	R 1"	R 1"	R 1"	R 1"	R 1 1/4"	R 1 1/4"	R 1 1/4"
Flue gas connection	Ø mm	180	200	200	225	225	250	250	300
device dimensions:									
Height	mm	1.145	1.145	1.145	1.145	1.145	1.145	1.145	1.145
Width	mm	850	930	1.010	1.170	1.250	1.410	1.570	1.730
Depth	mm	960	960	960	960	960	960	960	1.012
Weight	kg	317	343	369	421	447	499	550	601
Water content:	kg	28	31	34	41	44	51	57	73
Operating weight	kg	345	374	403	462	491	550	607	674
Category	-	EN: II <sub>2ELL3P</sub> ; AT: II <sub>2H3P</sub> ; GB: II <sub>2H3P</sub>							

**Table 12.1 Technical data**

- 1) With reference to thermal value H<sub>i</sub>
- 2) Determined in accordance with DIN 4702 Part 8
- 3) Calculated value for dimensioning the chimney in accordance with DIN 4705
- 4) With reference to 15 °C and 1013 mbar
- 5) Hamburger feed model is fulfilled
- 6) Determined in accordance with DIN 4708 Part 3
- 7) With equipment connection piece Order No. 303 907

**Vaillant Ltd**

Vaillant House ■ Medway City Estate ■ Trident Close ■ Rochester ■ Kent ME2 4EZ  
Telephone 01634 292300 ■ Fax 01634 290166 ■ [www.vaillant.co.uk](http://www.vaillant.co.uk) ■ [info@vaillant.co.uk](mailto:info@vaillant.co.uk)

**Vaillant Austria GmbH**

Forchheimergasse 7 ■ A-1230 Wien ■ Telefon 05/7050-0  
Telefax 05/7050-1199 ■ [www.vaillant.at](http://www.vaillant.at) ■ [info@vaillant.at](mailto:info@vaillant.at)

**Vaillant GmbH**

Berghauser Str. 40 ■ 42859 Remscheid ■ Telefon 0 21 91/18-0  
Telefax 0 21 91/18-28 10 ■ [www.vaillant.de](http://www.vaillant.de) ■ [info@vaillant.de](mailto:info@vaillant.de)