

IDC 2XX WITH COLD CARBONATION

Service Manual



Release Date: October 2, 2007

Publication Number: 621057403SER

Revision Date: August 3, 2010

Revision: A

Visit the IMI Cornelius web site at www.cornelius.com for all your Literature needs.

The products, technical information, and instructions contained in this manual are subject to change without notice. These instructions are not intended to cover all details or variations of the equipment, nor to provide for every possible contingency in the installation, operation or maintenance of this equipment. This manual assumes that the person(s) working on the equipment have been trained and are skilled in working with electrical, plumbing, pneumatic, and mechanical equipment. It is assumed that appropriate safety precautions are taken and that all local safety and construction requirements are being met, in addition to the information contained in this manual.

This Product is warranted only as provided in Cornelius' Commercial Warranty applicable to this Product and is subject to all of the restrictions and limitations contained in the Commercial Warranty.

Cornelius will not be responsible for any repair, replacement or other service required by or loss or damage resulting from any of the following occurrences, including but not limited to, (1) other than normal and proper use and normal service conditions with respect to the Product, (2) improper voltage, (3) inadequate wiring, (4) abuse, (5) accident, (6) alteration, (7) misuse, (8) neglect, (9) unauthorized repair or the failure to utilize suitably qualified and trained persons to perform service and/or repair of the Product, (10) improper cleaning, (11) failure to follow installation, operating, cleaning or maintenance instructions, (12) use of "non-authorized" parts (i.e., parts that are not 100% compatible with the Product) which use voids the entire warranty, (13) Product parts in contact with water or the product dispensed which are adversely impacted by changes in liquid scale or chemical composition.

Contact Information:

To inquire about current revisions of this and other documentation or for assistance with any Cornelius product contact:

www.cornelius.com

800-238-3600

Trademarks and Copyrights:

This document contains proprietary information and it may not be reproduced in any way without permission from Cornelius.

Printed in U.S.A.



TABLE OF CONTENTS

Safety Instructions	1
Read and Follow all Safety Instructions	1
Recognize Safety Alerts	1
Different Types of Alerts	1
Safety Tips	1
Qualified Service Personnel	1
Safety Precautions	2
Shipping And Storage	2
CO2 (Carbon Dioxide) Warning	2
Mounting in or on a Counter	2
Introduction	3
Description	3
Theory of Operation	3
Specification	3
Flow Diagrams - Eight Flavor Unit	4
Flow Diagrams - Ten Flavor Unit	5
E – Board Off Cycle Agitation Adjustments	6
Wiring Diagram	7
Schematic	8
Cleaning and Maintenance Instructions	9
Daily Cleaning	9
Daily Maintenance	9
Weekly Cleaning	9
Monthly Cleaning	10
Yearly Maintenance	10
Cold Plate (Yearly Maintenance)	10
Dispensing Valve (Daily Cleaning)	10
Product Tubing (Monthly Cleaning)	10
Sanitize Pre-Mix and Post Mix tank System	10
Sanitize Syrup Lines	11
Replenishing CO ₂ Supply (As Required)	11
Maintenance	12
Daily (or as required)	12
Checking CO ₂ Supply	12
Checking for CO ₂ and water leak	12
Monthly	12
Yearly	12
Water Pump Maintenance (or after water system disruption)	12
Cleaning CO ₂ Gas Check Valve	12
Change-out Procedures	13
Carbonated Water/Non Carbonated Water Change-out	13
Motor Replacement	14
Gearbox Replacement	15
Troubleshooting	16
Diagnostics Guide for the Main Control Board	19
Troubleshooting	20
Beverage Not Dispensing	20
Flat Drinks	21
No Carbonated Water	22

SAFETY INSTRUCTIONS

READ AND FOLLOW ALL SAFETY INSTRUCTIONS

Safety Overview

- Read and follow **ALL SAFETY INSTRUCTIONS** in this manual and any warning/caution labels on the unit (decals, labels or laminated cards).
- Read and understand ALL applicable OSHA (Occupational Safety and Health Administration) safety regulations before operating this unit.

Recognition

<i>Recognize Safety Alerts</i>
 <p><i>This is the safety alert symbol. When you see it in this manual or on the unit, be alert to the potential of personal injury or damage to the unit.</i></p>

DIFFERENT TYPES OF ALERTS

DANGER:

Indicates an immediate hazardous situation which if not avoided **WILL** result in serious injury, death or equipment damage.

WARNING:

Indicates a potentially hazardous situation which, if not avoided, **COULD** result in serious injury, death, or equipment damage.

CAUTION:

Indicates a potentially hazardous situation which, if not avoided, **MAY** result in minor or moderate injury or equipment damage.

SAFETY TIPS

- Carefully read and follow all safety messages in this manual and safety signs on the unit.
- Keep safety signs in good condition and replace missing or damaged items.
- Learn how to operate the unit and how to use the controls properly.
- **Do not** let anyone operate the unit without proper training. This appliance is **not** intended for use by very young children or infirm persons without supervision. Young children should be supervised to ensure that they do not play with the appliance.
- Keep your unit in proper working condition and do not allow unauthorized modifications to the unit.

QUALIFIED SERVICE PERSONNEL

WARNING:

Only trained and certified electrical, plumbing and refrigeration technicians should service this unit. **ALL WIRING AND PLUMBING MUST CONFORM TO NATIONAL AND LOCAL CODES. FAILURE TO COMPLY COULD RESULT IN SERIOUS INJURY, DEATH OR EQUIPMENT DAMAGE.**

SAFETY PRECAUTIONS

This unit has been specifically designed to provide protection against personal injury. To ensure continued protection observe the following:



WARNING:

Disconnect power to the unit before servicing following all lock out/tag out procedures established by the user. Verify all of the power is off to the unit before any work is performed.

Failure to disconnect the power could result in serious injury, death or equipment damage.



CAUTION:

Always be sure to keep area around the unit clean and free of clutter. Failure to keep this area clean may result in injury or equipment damage.

SHIPPING AND STORAGE



CAUTION:

Before shipping, storing, or relocating the unit, the unit must be sanitized and all sanitizing solution must be drained from the system. A freezing ambient environment will cause residual sanitizing solution or water remaining inside the unit to freeze resulting in damage to internal components.

CO₂ (CARBON DIOXIDE) WARNING



DANGER:

CO₂ displaces oxygen. Strict attention **MUST** be observed in the prevention of CO₂ gas leaks in the entire CO₂ and soft drink system. If a CO₂ gas leak is suspected, particularly in a small area, **IMMEDIATELY** ventilate the contaminated area before attempting to repair the leak. Personnel exposed to high concentrations of CO₂ gas experience tremors which are followed rapidly by loss of consciousness and **DEATH**.

MOUNTING IN OR ON A COUNTER



WARNING:

When installing the unit in or on a counter top, the counter must be able to support a weight in excess of **600 lbs.** to insure adequate support for the unit. **FAILURE TO COMPLY COULD RESULT IN SERIOUS INJURY, DEATH OR EQUIPMENT DAMAGE.**

NOTE: Many units incorporate the use of additional equipment such as icemakers. When any addition equipment is used you must check with the equipment manufacturer to determine the additional weight the counter will need to support to ensure a safe installation.

INTRODUCTION

DESCRIPTION

The IDC series of ice dispensers solves your ice and beverage service needs in a sanitary, space saving, economical way. Designed to be automatically filled with ice from a top mounted ice machine or manually filled with ice from any remote ice-making source, these dispensers will dispense cubes (up to 1-1/4 inch in size), cubelets, and compressed or extruded style ice. In addition, the units include beverage faucets, a cold plate, an internal carbonator tank and an external pump for the carbonator, and are designed to be supplied direct from syrup tanks with no additional cooling required.

THEORY OF OPERATION

The rate of CO₂ solubility increases with cold water. IDC System provides pre-chilled cold water from the cold plate and mix with CO₂ in the carbonator tank. The water is introduced into the tank with a high volume 125gph Procon pump and high torque motor.

The amount of carbonated water reserve is controlled by a probe mounted in the tank. The probe is called a "liquid level probe". The liquid level probe senses the water level in the tank. Probe controls the pump "ON" and "OFF" cycle through the "liquid level board" located on the main control board.

NOTE: The probe works on a 5 mVDC current that continually reverses direction to prevent probe corrosion.

SPECIFICATION

Model Descriptions:	IDC 215 B=Beverage C=Coldplate H=Internal Carb Z=No Drip Tray	IDC 255 B=Beverage C=Coldplate H=Internal Carb Z=No Drip Tray
Ice Storage:	215 Pounds	255 Pounds
Maximum Number of Faucets Available:	10	10
Built-in Cold Plate:	Yes	Yes
Electrical:	120/1/60, 9.3 Amps of Total Unit Draw 220/1/50, 4.7 Amps of Total Unit Draw	
Dimensions:	Width Depth Height	Width Depth Height
CO ₂ Operating Pressure	75-psig (max)	75-psig (max)

FLOW DIAGRAMS

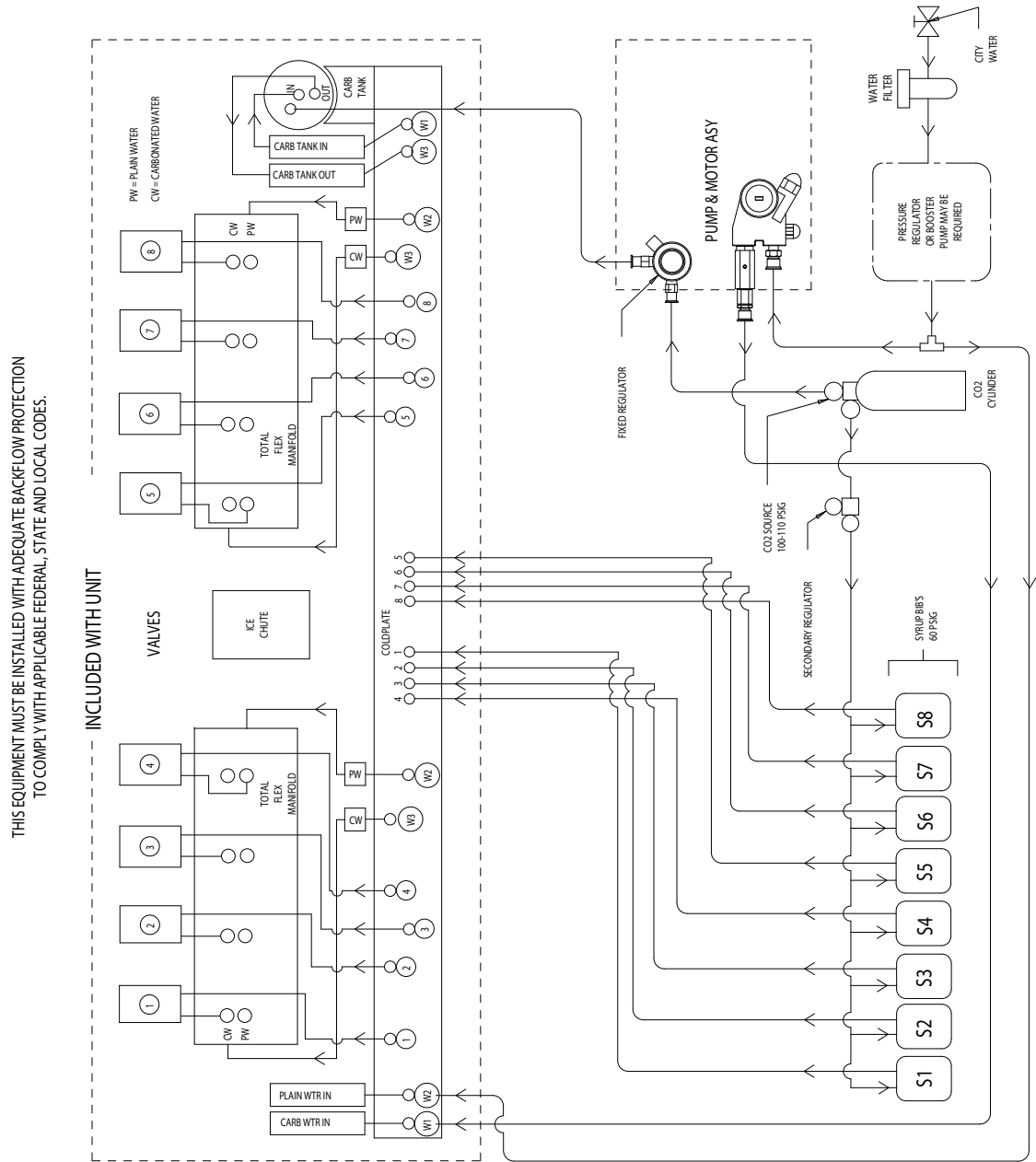

Figure 1. Flow Diagram - Eight Flavor Unit

THIS EQUIPMENT MUST BE INSTALLED WITH ADEQUATE BACKFLOW PROTECTION TO COMPLY WITH APPLICABLE FEDERAL, STATE AND LOCAL CODES.

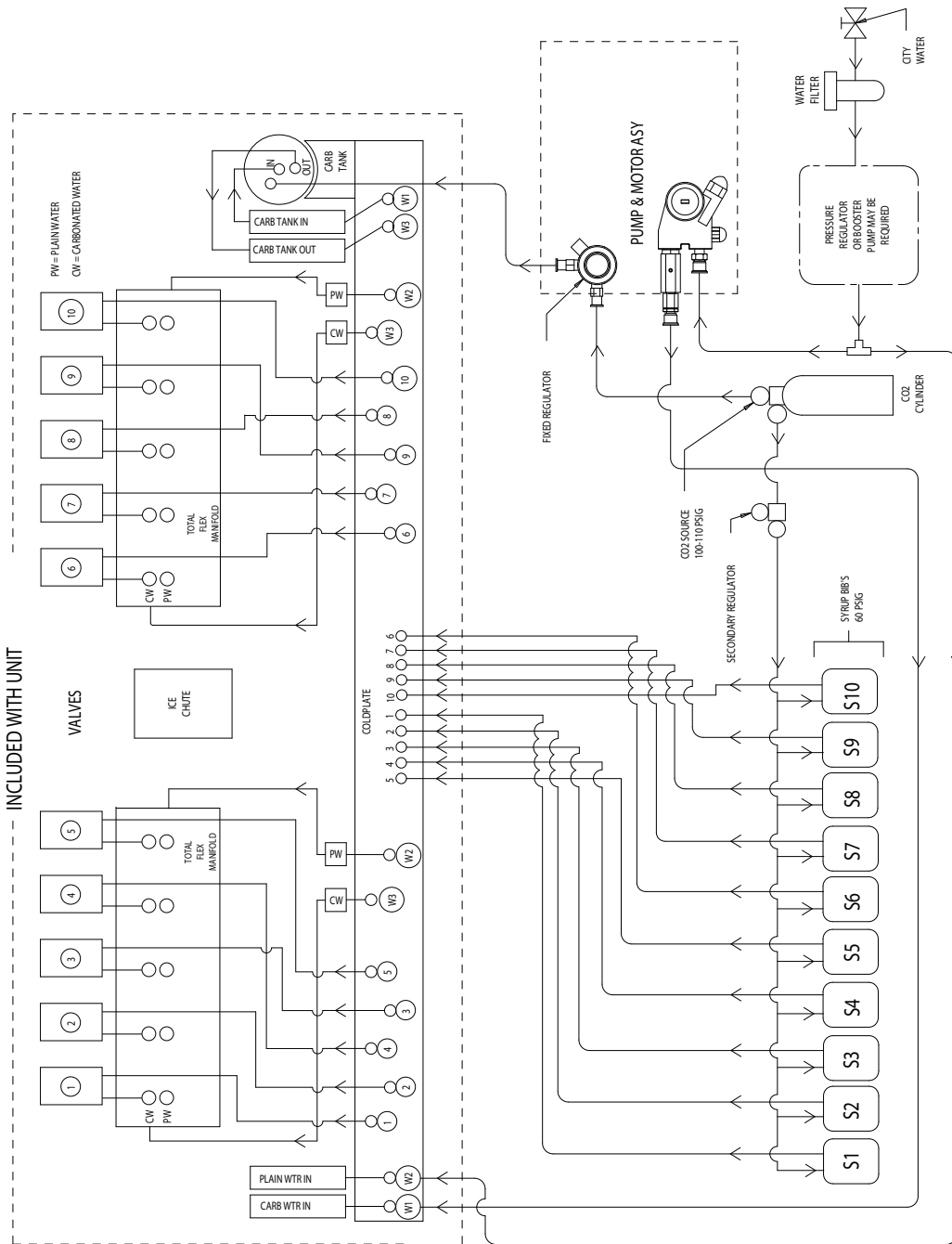

Figure 2. Flow Diagram - Ten Flavor Unit

E – BOARD OFF CYCLE AGITATION ADJUSTMENTS

When Ice is not being dispensed from the machine such as during off hours it is essential to move or agitate the ice to keep it from clumping and to replenish the ice in the cold plate. The amount of time the agitator runs and the time between the agitation cycles can be adjusted depending on ice type or application. The settings for this function are located on the E-Board found in the E-BOX. Using a screwdriver follow the diagram below and set the agitator for the desired settings.

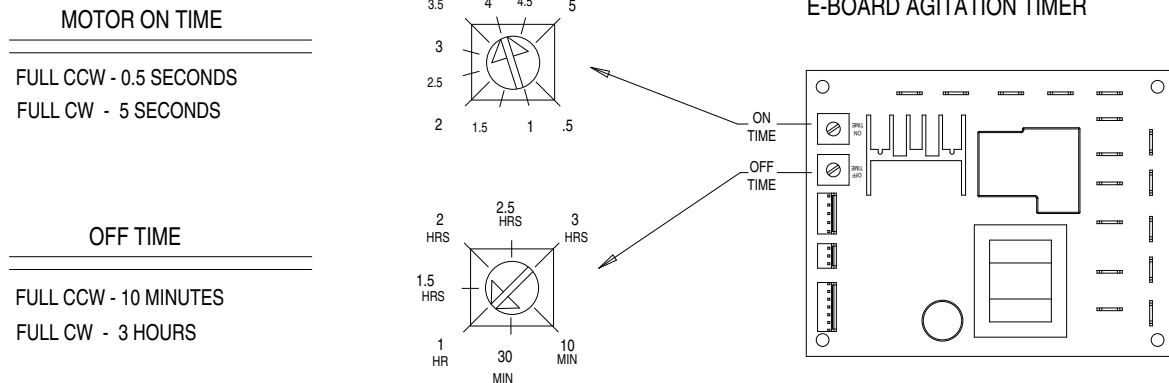
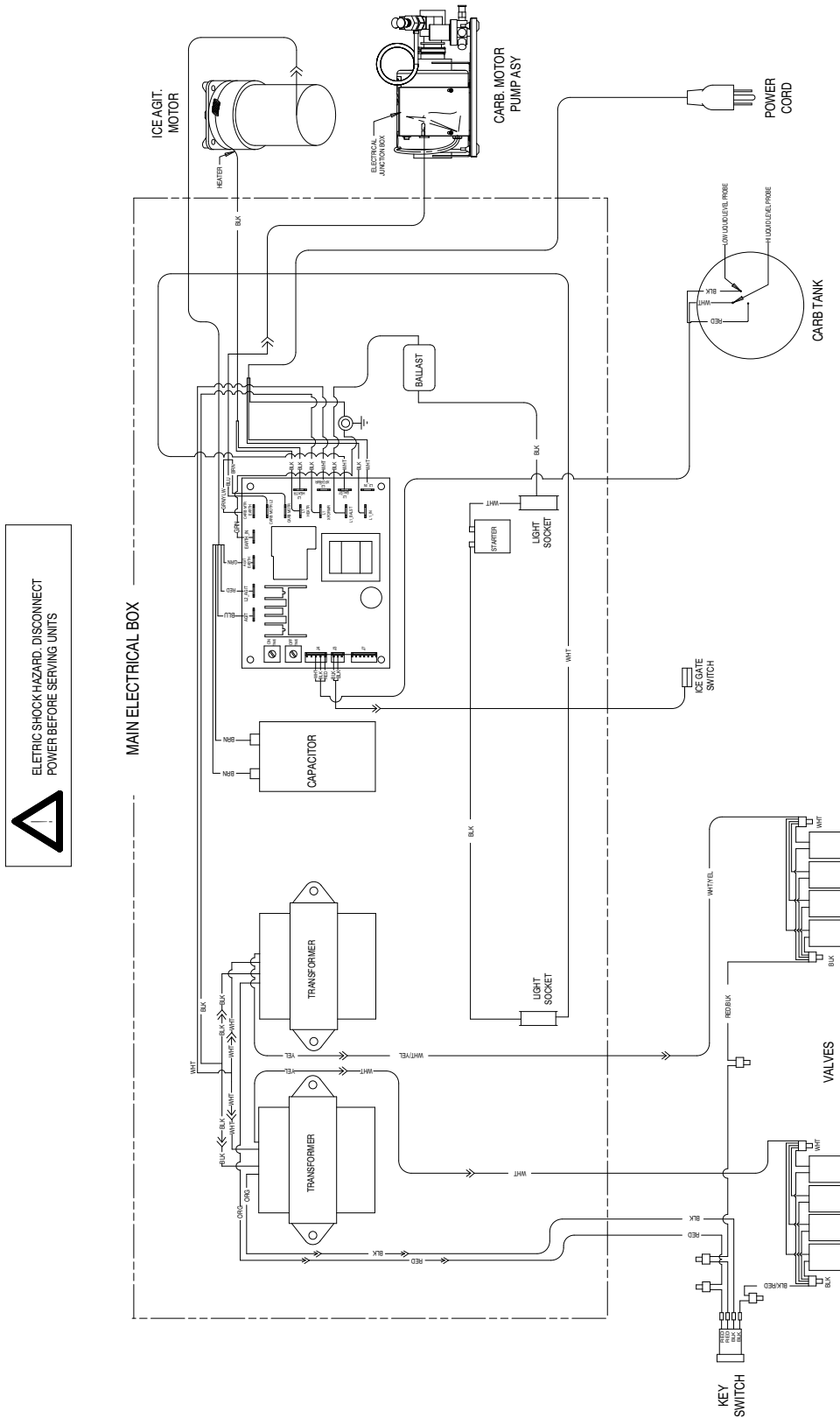

Figure 3

Manufacturer Recommended Agitation Settings			
Model	Ice Fill/Ice Type	Motor ON Time	Motor OFF time
175, 215, &255, 300, B, BC	Manual/Hard Ice (Cube)	4 Seconds	1 Hour
	Automatic (Top-Mount Ice Maker/ Hard Ice (Cube)	0.5 Seconds	20 Minutes
	Manual & Automatic/Cornelius Chunklet, Scotsman & Hoshizaki Compressed Ice	0.5 Seconds	3 Hours
B - Beverage C-Coldplate		*NO FLAKED ICE*	

WIRING DIAGRAM



⚠
ELECTRIC SHOCK HAZARD. DISCONNECT
POWER BEFORE SERVING UNITS

Wiring Diagram

SCHEMATIC

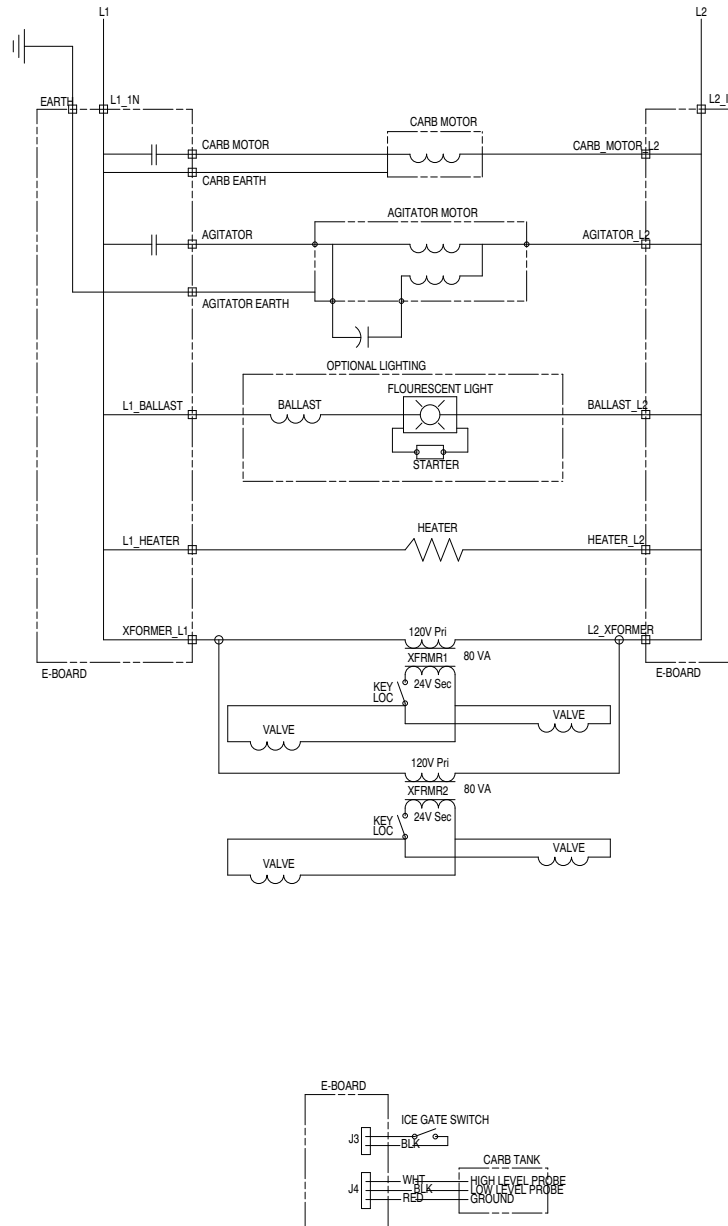

FIGURE 5. Wiring Schematic

CLEANING AND MAINTENANCE INSTRUCTIONS

These instructions are used on all Cornelius ice drink dispensers.
Some models may have additional cleaning requirements.
Those models will have addition procedures listed later in the manual.

WARNING:

Disconnect power to the unit before cleaning or servicing following all lock out / tag out procedures established by the user. Verify all of the power is off to the unit before performing any work.

Failure to comply could result in serious injury, death or damage to the equipment.

CAUTION:

Do not use metal scrapers, sharp objects or abrasives on the ice storage hopper, top cover, agitator disc or exterior surfaces as damage to the unit may result. Do not use solvents or other cleaning agents as they may attack the material resulting in damage to the unit.

Soap solution – Use a mixture of mild detergent and warm (100° F) potable water.

Sanitizing Solution – Dissolve 2 packets (4 oz) of Stera Sheen Green Label into 2 gallons of warm (80 – 100° F) potable water to ensure 200 ppm of chlorine.

Daily Cleaning:

1. Remove cup rest from drip tray and clean with warm soapy water, rinse with clean water and allow to air dry.
2. Wipe down the exterior of the unit with warm soapy water, rinse with clean water and allow to air dry.
3. Remove valve nozzles and diffusers and wash in warm soapy water, rinse in clean water and allow to air dry.
4. Clean the interior of the ice chute using the brush provided with the unit with warm soapy water, rinse with clean water and allow to air dry.
5. Spray the ice chute inside and out with sanitizer and allow to air dry.
6. Pour warm soapy water down the drains to keep them clean and flowing smoothly.
7. Spray the nozzles and diffusers inside and outside with approved sanitizing solution, reinstall them on the valves and allow to air dry.
8. Reinstall the cup rest into the drip tray.
9. Pour all remaining sanitizer solution down the drains to help keep the drain clear.

Daily Maintenance:

1. Check the temperature, smell and taste of the product.
2. Check the water pressure coming to the unit using the pressure gauges on the back room package.
3. Check carbonation of the drink
4. Check level of CO2 supply to the system.
5. Check the date on all of the BIB's (bags in boxes).

Weekly Cleaning: (In addition to daily procedures)

Remove the ice chute cover and clean it along with the back half with warm soapy using the brush provided with the unit. Rinse with clean water and reinstall on the unit. Spray the ice chute assembly with approved sanitizer allowing it to air dry.

Monthly Cleaning: (In addition to daily and weekly procedures)

1. Flush and sanitize all syrup lines as well as all of the syrup connectors. (See the sanitize syrup lines section shown later in this manual).
2. Remove ice from hopper and clean and sanitize the hopper. (See the Cleaning the interior surfaces section shown later in this manual).
3. While cleaning the hopper use the brush provided with the unit to clean the cold plate surface. To accomplish this, the brush needs to be extended through the opening in the bottom of the hopper.

Yearly Maintenance:

Have the water pump and check valve inspected and cleaned by a qualified service technician.

Have the CO₂ gas check valve inspected and cleaned by a qualified service technician.

Remove the unit's splash and cold plate cover to clean and sanitize the cold plate surface. (See the cleaning the cold plate section shown later in this manual).

Cold Plate (Yearly Maintenance)

1. Remove splash panel.
2. Remove or move the plastic cold plate cover to expose the cold plate.
3. Locate and remove any debris from the drain trough. Check that the drain holes are not clogged.
4. Pour small amount of soap solution through cold plate openings in hopper.
5. Using a cloth, wash down the surfaces of the cold plate and plastic cover with soap solution.
6. Install and properly position the access covers on the cold plate.
7. Install the splash panel in the reverse order it was removed.
8. Rinse cold plate surface by pouring potable water through hopper openings.

Dispensing Valves: (Daily Cleaning)

Refer to addendum supplied with the unit that is applicable to the manufacturer of the valves installed on the unit.

Product Tubing (Monthly Cleaning)

IMPORTANT: Only trained and qualified persons should perform these cleaning and sanitizing procedures.

Sanitize Pre-Mix And Post-Mix tank System

1. Remove all the quick disconnects from all the tanks. Fill a suitable pail or bucket with soap solution.
2. Submerge all disconnects (gas and liquid) in the soap solution and then clean them using a nylon bristle brush. (**Do not use a wire brush**). Rinse with clean water.
3. Prepare sanitizing solution and using a mechanical spray bottle, spray the disconnects. Allow to air dry.
4. Using a clean, empty tank, prepare five (5) gallons of the sanitizing solution. Rinse the tank disconnects with approximately 9 oz. of the sanitizing solution. Close the tank.
5. Prepare cleaning tank by filling clean five (5) gallon tank with a mixture of mild detergent and potable water (120°F).
6. Connect a gas disconnect to the tank and then apply one of the product tubes to the cleaning tank. Operate the appropriate valve until liquid dispensed is free of any syrup.
7. Disconnect cleaning tank and hook up sanitizing tank to syrup line and CO₂ system.
8. Energize beverage faucet until chlorine sanitizing solution is dispensed through the faucet. Flush at least two (2) cups of liquid to ensure that the sanitizing solution has filled the entire length of the syrup tubing.

9. Allow sanitizer to remain in lines for fifteen (15) minutes.
10. Repeat the step above, applying a different product tube each time until all tubes are filled with the sanitizing solution.
11. Remove the nozzle and syrup diffuser and clean them in a mild soap solution. Rinse with clean water and reassemble the nozzle and syrup diffuser on the valve.
12. Rinse the parts in clean water, reassemble the valve and reconnect it to the dispenser.
13. Discard the tank of sanitizing solution and reconnect the product syrup tanks. Operate the valves until all sanitizer has been flushed from the system and only product syrup is flowing.

Sanitize syrup lines, B-I-B Systems

1. Remove all the quick disconnects from all the B-I-B containers.
2. Fill a suitable pail or bucket with soap solution.
3. Submerge all disconnects (gas and liquid) in the soap solution and then clean them using a nylon bristle brush. (Do not use a wire brush). Rinse with clean water.
4. Using a plastic pail, prepare approximately five (5) gallons of sanitizing solution.
5. Rinse the B-I-B disconnects in the sanitizing solution.
6. Sanitizing fittings must be attached to each B-I-B disconnect. If these fittings are not available, the fittings from empty B-I-B bags can be cut from the bags and used. These fittings open the disconnect so the sanitizing solution can be drawn through the disconnect.
7. Place all the B-I-B disconnects into the pail of sanitizing solution. Operate all the valves until the sanitizing solution is flowing from the valve. Allow sanitizer to remain in lines for fifteen (15) minutes.
8. Remove the nozzle and syrup diffuser from each valve and clean them in a soap solution. Rinse with clean water and reassemble the nozzle and syrup diffuser to the valve.
9. Remove the sanitizing fittings from the B-I-B disconnects and connect the disconnects to the appropriate B-I-B container. Operate the valves until all sanitizer has been flushed from the system and syrup is flowing freely.

Replenishing CO₂ Supply (As Required)

NOTE: When indicator on the 1800-psi gage is in the shaded (“change CO₂ cylinder”) portion of the dial, CO₂ cylinder is almost empty and should be changed.

1. Fully close (clockwise) the CO₂ cylinder valve.
2. Slowly loosen the CO₂ regulator assembly coupling nut allowing CO₂ pressure to escape, then remove the regulator assembly from the empty CO₂ cylinder.
3. Unfasten safety chain and remove the empty CO₂ cylinder.

WARNING:

To avoid personnel injury and/or property damage, always secure the CO₂ cylinder with a safety chain to prevent it from falling over. Should the valve become accidentally damaged or broken off, a CO₂ regulator can cause serious personnel injury or death could occur.

4. Position the full CO₂ cylinder and secure with a safety chain.
5. Make sure gasket is in place inside the CO₂ regulator assembly coupling nut, then install the regulator assembly on the CO₂ cylinder.
6. Open (counterclockwise) the CO₂ cylinder valve slightly to allow the lines to slowly fill with gas, then open the valve fully to back-seat the valve (back-seating the valve prevents gas leakage around the valve shaft). Check CO₂ connections for leaks. Tighten any loose connections.

MAINTENANCE

The following dispenser maintenance should be performed at the intervals indicated:

DAILY (OR AS REQUIRED)

Remove foreign material from vending area drip tray to prevent drain blockage.

Clean vending area. Check for proper water drainage from the vending area drip tray.

Checking CO₂ Supply

Make sure CO₂ cylinder regulator assembly 1800-psi gage indicator is not in shaded (“change CO₂ cylinder”) portion of the dial. If so, the CO₂ cylinder is almost empty and must be replaced.

Checking for CO₂ and water leak

Check the Unit for CO₂ and water leaks and if found, call a qualified Service Person to repair as necessary.

MONTHLY

Clean and sanitize the hopper interior and beverage system, if applicable (see CLEANING INSTRUCTIONS).

YEARLY

Water Pump Maintenance (or after water system disruption)

The water pump water strainer screen and the liquid dual check valve must be inspected and cleaned at least once a year under normal circumstances and after any water system disruption (plumbing work, earthquake, etc.). Call a qualified Service Person to inspect and clean the strainer screen and the liquid dual check valve.

Cleaning CO₂ Gas Check Valve

The CO₂ gas check valve, located on the carbonated water tank, must be inspected and serviced at least once a year under normal conditions and after any CO₂ system servicing disruption. Call a qualified Service Person to inspect and clean the CO₂ gas check valve.

NOTE: If the power cord is damaged, it must be replaced by the manufacturer, its service agent or similar qualified persons in order to avoid a hazardous situation.

CHANGE-OUT PROCEDURES

CARBONATED WATER/NON CARBONATED WATER CHANGE-OUT

1. Depressurize the system.
IMPORTANT: Both the syrup and water must be depressurized.
2. Push the valve lock down on the valve that needs the water type change and pull the valve off the back block.
3. Remove the 4 screws holding the back block in place and remove the back block.

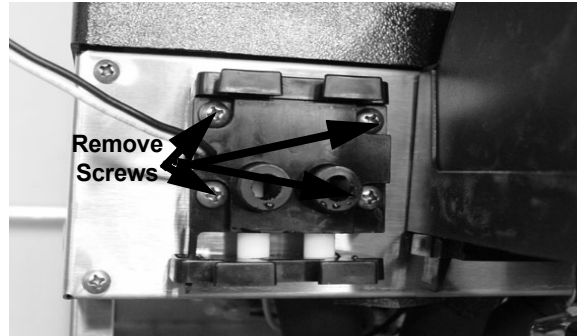

4. Pull the Y-fitting out by moving it from side to side until it releases.

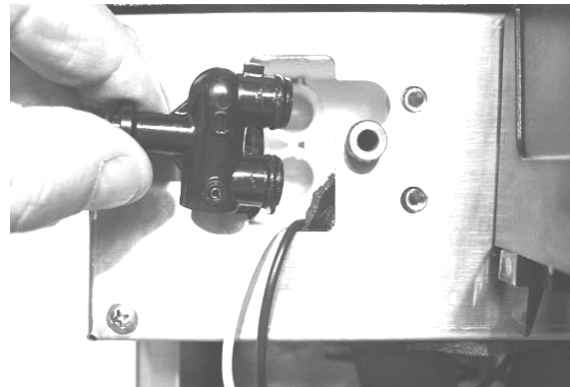
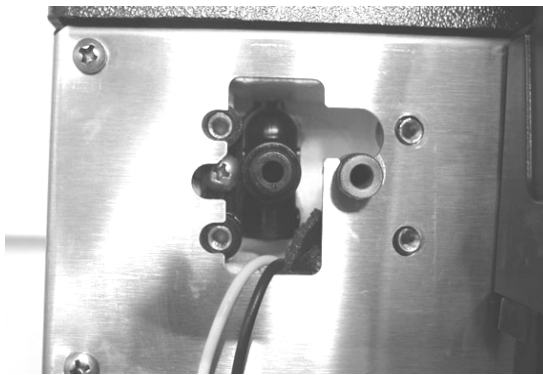

5. Insert the Carbonated or Non-carbonated Y-fitting into the manifold.

NOTE: There is a tab on the top of the fittings to assist in proper installation.

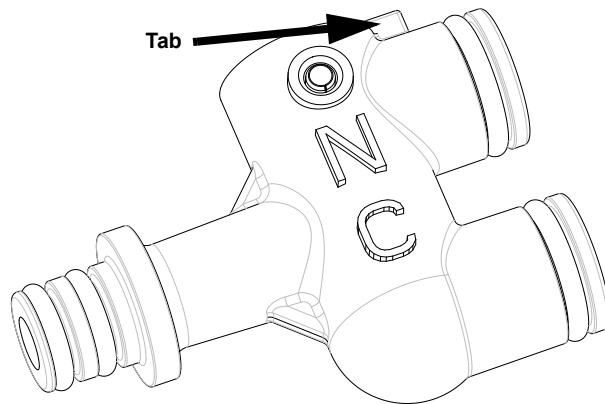
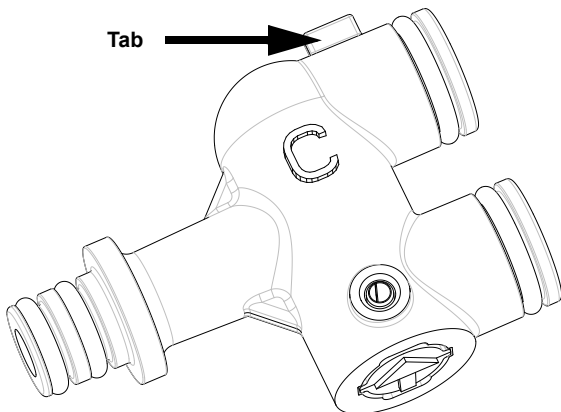

6. Replace the back block and screw it in place.
7. Place the valve on the back block and lock in place.
8. Repeat for remaining valves, if necessary.
9. Reinststate pressure to syrup and water systems.
10. Proceed with valve set up.

MOTOR REPLACEMENT

1. Remove the 4 screws with a 1/4" socket to separate the agitator motor from the gear box.

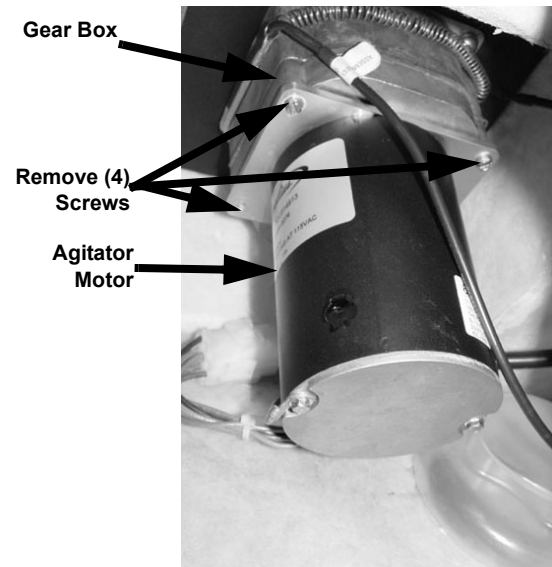

2. Remove the agitator motor.
3. Install the new agitator motor and replace the screws removed in step 1 with a 1/4" socket.



GEARBOX REPLACEMENT

1. Remove the 4 screws with a 1/4" socket to separate the agitator motor from the gear box.
2. Remove the 4 screws holding the gear box in place with a 3/16 hex wrench.

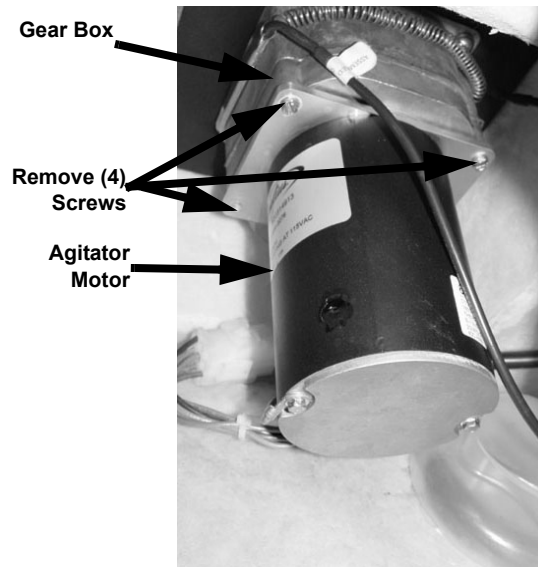

3. Pull the gear box, seal, and gasket off the machine.
4. Install the new gear box, seal, and gasket. Screw it in place with the 4 screws removed in step 4 using a 3/16 hex wrench.
5. Replace the motor with the 2 screws removed in step 1 using a 1/4" socket.

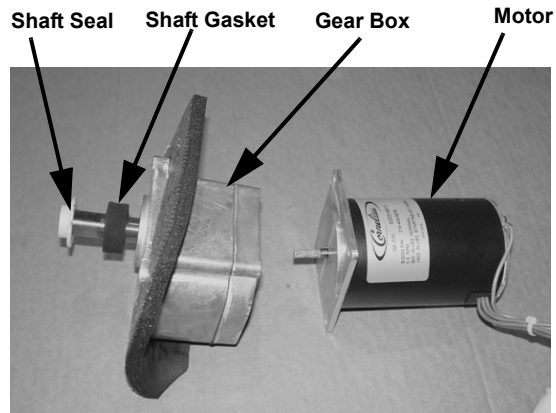

TROUBLESHOOTING

IMPORTANT: Only qualified personnel should service internal components or electrical wiring.



WARNING: If repairs are to be made to a product system, remove quick disconnects from the applicable product tank, then relieve the system pressure before proceeding. If repairs are to be made to the CO₂ system, stop dispensing, shut off the CO₂ supply, then relieve the system pressure before proceeding. If repairs are to be made to the refrigeration system, make sure electrical power is disconnected from the unit.

Should your unit fail to operate properly, check that there is power to the unit and that the hopper contains ice. If the unit does not dispense, check the following chart under the appropriate symptoms to aid in locating the defect.

Dispenser Troubleshooting		
Symptom	Cause	Remedy
Blown fuse or circuit breaker	Short circuit in electrical wiring	Repair Wiring
	Inoperable agitator motor (shorted motor)	Replace gear motor
Agitator does not turn	No power	Restore power or plug in unit
	Improperly installed upper ice chute assembly (Reed switch is not being activated)	Check the upper ice chute assembly for proper assembly and operation
	Inoperable reed switch	Replace reed switch
	Electrical board driver circuit is defective	Replace main control board
	Gear motor has open circuit	Replace gear motor
	Reed switch is not activated Improper assembly of upper ice chute to lower chute.	Check to make sure tongue of upper chute engages into the back of the lower chute, ensure upper chute engages outside the lower chute, and snap front of chute into place.
	Broken wire in the 2-wire harness leading to the reed switch	Repair or replace 2-wire harness
Ice dispenses continuously	Bad connection at main control board, J3, pins 2 & 3	Repair connection or replace 2-wire harness
	Ice gate mechanism is stuck in open position	Inspect gasket for proper position. Examine gate plate to see if it slides freely behind the lower ice chute.
	Stuck or bent ice lever (does not allow gate to close and open reed switch)	Examine ice dispense lever to see if it is bent.

Slushy ice or water in hopper	Blocked drains in cold plate	Remove access covers in cold plate cover & inspect/clean drains
	Poor ice quality due to water quality or ice maker problems	Correct water quality or repair ice maker
Beverage does not dispense	No 24VAC to valves	Restore 24 VAC to valves
	No CO ₂ pressure	Restore CO ₂ pressure
Beverage is too sweet	Valve brix requires adjustment	Adjust valve brix
	Carbonator is not operating	Repair carbonator
	No CO ₂ in carbonator	Restore CO ₂ pressure in carbonator
	City water pressure supply low or inconsistent	Booster pump must be used if dynamic water pressure drops below 40 psig.
Unit will not dispense carbonated drinks. Dispenses syrup only.	CO ₂ pressure in carbonator tank is too high.	Check CO ₂ pressure regulator setting. 75 psig recommended. Relieve pressure from carbonator tank.
	Water valve will not open	Check electrical connection to water valve. Check resistance of coil (should be 9 ohms). Check for voltage at coil when brand button is depressed.
Unit will not dispense carbonated drinks. Spurts CO ₂ and syrup only.	Carbonator tank is empty, because tank was emptied while power was applied to unit. 5 minute time-out of carbonator pump/motor occurred, and carbonator pump is locked off.	Unplug the unit and reconnect the unit. Main control board will reset, ice agitation will occur, and carbonator tank will refill to normal level.
	Note that this can occur while the water filter system is serviced or water supply is shutoff. If drinks are drawn from the dispenser while water pressure is shutoff, the carbonator pump starts and runs continuously, then shuts off on the 5 minute timeout.	1) low water pressure switch deactivates carbonator pump, 2) after 5 minutes reset and retry carbonator pump. If water supply is restored, the 5 minute timeout will not occur. Repeat reset a second time, but on a third time, then lockout carbonator pump, which will generate a service call.
Carbonated drinks are flat (low on carbonation)	CO ₂ is out	Replace CO ₂
	Carbonator tank is 100% filled because the city water pressure exceeds the carbonator tank CO ₂ pressure regulator setting.	CO ₂ setting for the carbonator tank is 75 psig, max water pressure is 60 psig. If necessary, install a water pressure regulating valve.



Low water pressure	Could be caused by excessively long runs (over 40 ft.) of 3/8" water supply line.	Increase line size to 1/2"
	Low water pressure	Add water pressure booster pump
	Plugged water filter.	Change water filter
	Water booster bladder has burst	Replace water booster tank/bladder
No Syrup or Watered down drink dispensed	Syrup supply is empty	Replace BIB
	BIB pump not working	Replace BIB pump
	No CO ₂ or compressed air supply to BIB pump, or not enough pressure	Check CO ₂ pressure regulator setting. 65 psig recommended. Replace CO ₂ tank or fix compressor.

Carbonator Troubleshooting

Symptom	Cause	Remedy
Carbonator pump does not start to fill tank	Power cord for the carbonator pump motor is not connected.	Carbonator pump is powered off the main control board inside the electrical box of the unit. Check that the umbilical cord is connected from the unit to the pump motor terminal box.
Power cord is connected but carbonator pump does not run.	Carbonator pump motor is disabled.	Check the enable/disable switch on the carbonator pump terminal box and enable it, if necessary.
	Probes were dry, unit was powered up, water was not turned on, and carbonator did not fill.	This results in a 5 minute timeout. Unplugging the unit and plugging it in will reset the unit and start the carbonator pump.
	Water service was interrupted for more than 5 minutes.	Unplugging the unit and plugging it in will reset the unit and start the carbonator pump.
Carbonator pump is short cycling with every drink drawn	Lower liquid level probe reads "dry" while upper probe reads "wet"	Check color of leads going to probes. Black should go to bottom probe and white to top probe. Reverse if incorrect.
Carbonator tank overfills, overflows through relief valve, and pump shuts off after 5 minutes.	A. Poor electrical connections between carbonator tank and main control board	A. Check connections at carbonator tank and at connector J4 on the main control board.
	B. Broken wires between carbonator tank and main control board	B. Replace wire harness
	C. Defective liquid level probes	C. Replace both liquid level probes

Contact your local syrup or beverage equipment distributor for additional information and troubleshooting of beverage system.

DIAGNOSTICS GUIDE FOR THE MAIN CONTROL BOARD

State	Observed State of Red LED	Sensor Input	Control Response	Service Remedy
0	Flash rate 3 seconds	Both probes read "wet"	Standby mode. Pump = OFF	No service required
1	Flash rate 1/2 second	Pump is OFF and HIGH probe reads "dry" and LOW probe reads "wet"	Waiting for level to drop below LOW probe. Pump = OFF	No service required
2	Flash rate 1/2 second	Both HIGH and LOW probes read "dry"	Normal mode. Pump = ON	No service required
3	Flash rate 1/2 second	Entered when HIGH probe does not detect liquid, and LOW probe does detect liquid, and pump is ON	Normal mode. Pump = ON	No service required
4	Flash rate 1 second	Entered when HIGH probe reads "wet" and LOW probe reads "dry"	THIS IS AN ERROR CONDITION.	<ul style="list-style-type: none"> - Check electrical connections at the carbonator tank, and at connector J4 on the main control board - Black wire should be connected to the LOW probe and also to Pin 4 of Connector J4 - Reverse the connections if incorrect - Replace harness if necessary
5	ON continuously, but "flickers" every 3 seconds	Poor signal connection to the carbonator tank. May result in short cycling of the carbonator pump.	Able to continue to function but carbonator pump short-cycles. Pump will come on each time a drink is drawn. THIS SITUATION SHOULD BE CORRECTED.	Check the harness connections of the red signal wire at both ends: 1) at the carbonator ring terminal and 2) at Pin 5 of the J4 connector at the main control board
6	ON continuously	Entered when pump has run continuously for 5 minutes	THIS IS AN ERROR CONDITION.	Unplug the unit and plug it back in. This will reset the unit's main control board and restart the carbonator pump.

TROUBLESHOOTING

Beverage Not Dispensing

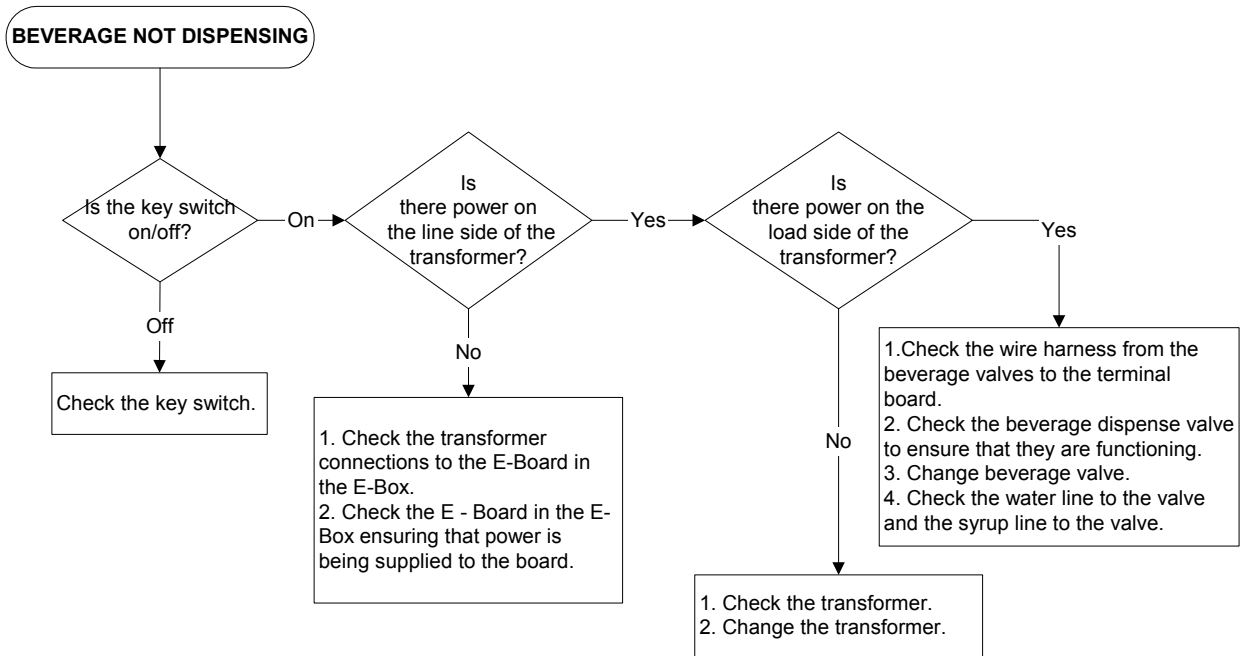

Flat Drinks

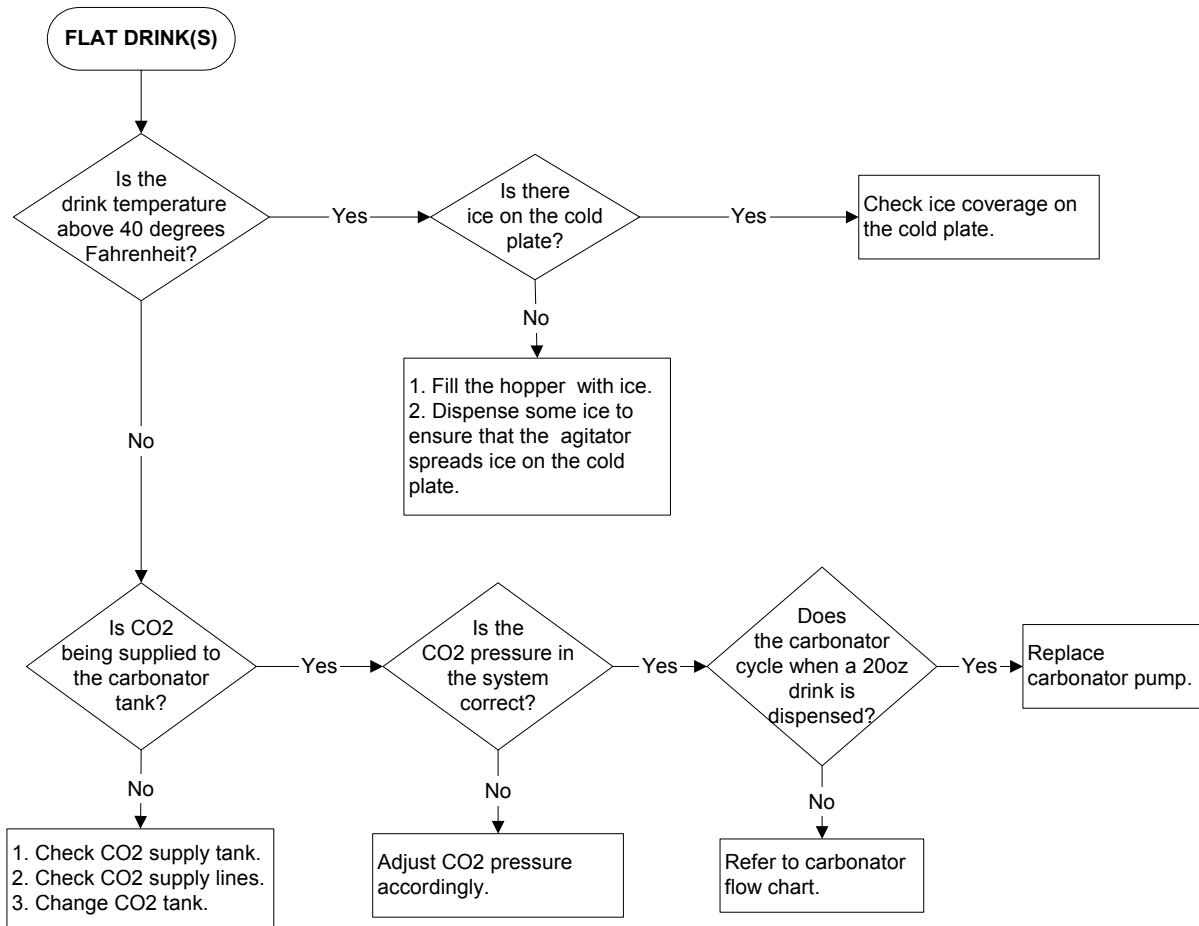

No Carbonated Water

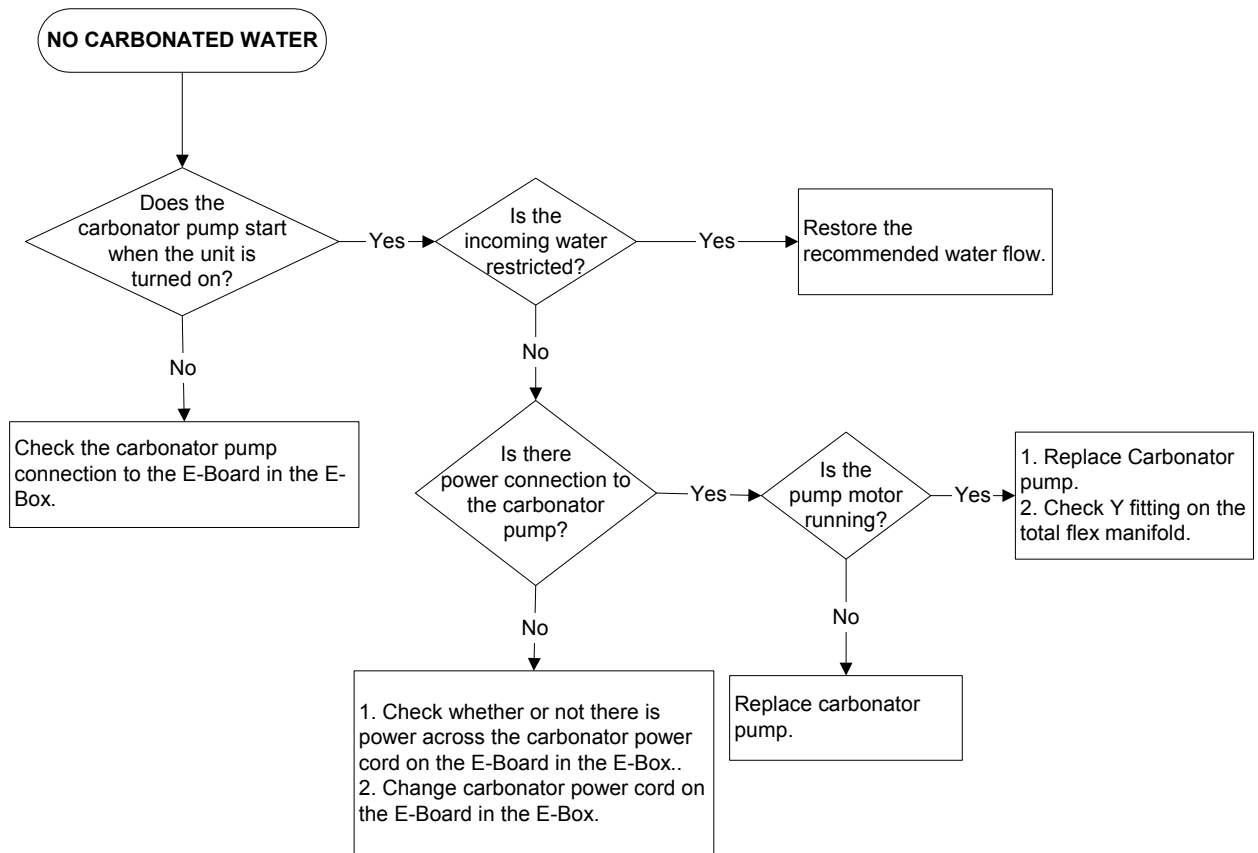



IMI Cornelius Inc.
www.cornelius.com