

Service Manual

LCD Monitor E1709W

Service Manual Versions and Revision

No.	Version	Release Date	Revision
1	1.0	2008/08/25	Initial Release

Copyright

Copyright 2007 InnoLux Display. Corp. Ltd

All Rights Reserved

This manual may not, in whole or in part, be copied, Photocopied, reproduced, translated, or converted to any electronic or machine readable form without prior written permission of Foxconn Tech. Corp. Ltd.

Dell E1709W Service Manual

Table of Contents

CHAPTER 1- PRECAUTIONS & SAFETY NOTICES	3
1. SAFETY PRECAUTIONS	3
2. PRODUCT SAFETY NOTICE	3
3. SERVICE NOTES	3
CHAPTER 2- SERVICE TOOLS & EQUIPMENT REQUIRED	4
CHAPTER 3- CIRCUIT THEORY.....	5
1. BLOCK DIAGRAM	5
2. ELECTRONIC CIRCUIT THEORY	7
3. FACTORY PRESET TIMING TABLE.....	13
4. POWER ON/OFF SEQUENCY.....	13
5. D-SUB CONNECTOR PIN ASSIGNMENT	14
6. AC OUTLET PIN ASSIGNMENT	14
7. INNER CONNECTOR PIN ASSIGNMENT.....	14
8. KEY PARTS PIN ASSIGNMENTS.....	16
CHAPTER 4- DISASSEMBLY & ASSEMBLY	21
1. EXPLODED DIAGRAM	21
2. E1709WFPF DISASSEMBLY BLOCK.....	22
3. ASSEMBLY BLOCK	23
CHAPTER 5- TEST AND ADJUSTMENT	24
1. FUNCTION KEY DEFINITIONS	24
2. OSD CONTROL.....	24
3. FACTORY MODE INTRODUCTION.....	26
4. BURN-IN PATTERN.....	27
5. AUTO COLOR BALANCE (AUTOMATICALLY CALIBRATE CHIP ADC PARAMETER BY USING CHIP INTERNAL DAC.).....	27
6. UPLOAD FIRMWARE TO MCU VIA VGA CABLE	26
7. AFTER REPAIR, TO ENSURE THE QUALITY YOU SHOULD DO THE FOLLOWING TEST AND ADJUSTMENT.....	27
CHAPTER 6- TROUBLE SHOOTING.....	30
1. COMMON ACKNOWLEDGE.....	30
2. NO POWER LED OFF	30
3. POWER NORMAL LED AMBER	31
4. BACKLIGHT CAN'T BE TURNED ON	32
5. NO PICTURE BACKLIGHT ON.....	33
6. AT 32-GRAY SCALE PATTERN, COLOR LOST IN SOME SCALE.....	34
CHAPTER 7- RECOMMENDED PART LIST.....	35
ATTACHMENT 1- BILL OF MATERIAL	37
ATTACHMENT 2- SCHEMATIC	47
ATTACHMENT 3- PCB LAYOUT	52

Chapter 1- PRECAUTIONS & SAFETY NOTICES

SAFETY PRECAUTIONS

This monitor is manufactured and tested on a ground principle that a user's safety comes first. However, improper used or installation may cause damage to the monitor as well as to the user.

WARNINGS:

- This monitor should be operated only at the correct power sources indicated on the rating label on the rear cover of the monitor. If you're unsure the power supply in your residence, consult your local dealer or Power Company.
- Use only the specified power cord that comes with this monitor.
- Do not try to repair the monitor by yourself, as it contains no user-serviceable parts. This monitor should only be repaired by a qualified technician.
- Do not remove the monitor cabinet. There is high-voltage parts inside that may cause electric shock to human bodies.
- Stop using the monitor if the cabinet is damaged. Have it checked by a service technician.
- Put your monitor only in a lean, cool, dry environment. If it gets wet, unplug the power cable immediately and consult your closed dealer.
- Always unplug the monitor before cleaning it. Clean the cabinet with a clean, dry cloth. Apply non-ammonia based cleaner onto the cloth, not directly onto the class screen.
- Do not place heavy objects on the monitor or power cord.

PRODUCT SAFETY NOTICE

Many electrical and mechanical parts in this chassis have special safety visual inspections and the protection afforded by them cannot necessarily be obtained by using replacement components rated for higher voltage, wattage, etc. Before replacing any of these components read the parts list in this manual carefully. The use of substitute replacement parts, which do not have the same safety characteristics as specified in the parts list, may create shock, fire, or other hazards.

SERVICE NOTES

- When replacing parts on circuit boards, clamp the solder wires around terminals before soldering.
- Keep wires away from high voltage, high temperature components and sharp edges.
- Keep wires in their original position so as to reduce interference.
- Adjustment of this product please refers to the user' manual.
- Use Pb free solder wire for circuit board preparation.

Chapter 2- SERVICE TOOLS & EQUIPMENT REQUIRED

1. SIGNAL GENERATOR
2. MULTIMETER
3. SCREW DRIVER
4. OSCILLOSCOPE
5. Soldering IRON
6. SOLDER (Lead free, RoHS compliance)
7. Color Analyzer
8. Fox_VISP_Programmer
9. Fox_VEDID_Programmer

Chapter 3- CIRCUIT THEORY

Block Diagram

There are 2pcs PCBA in this monitor, one is power& inverter board which is a single layer board, and one is interface board& keypad which is OSD control. The system function block diagram as below

This PWA is included switching power supplier, inverter for CCFL and interface board.(fig.1)

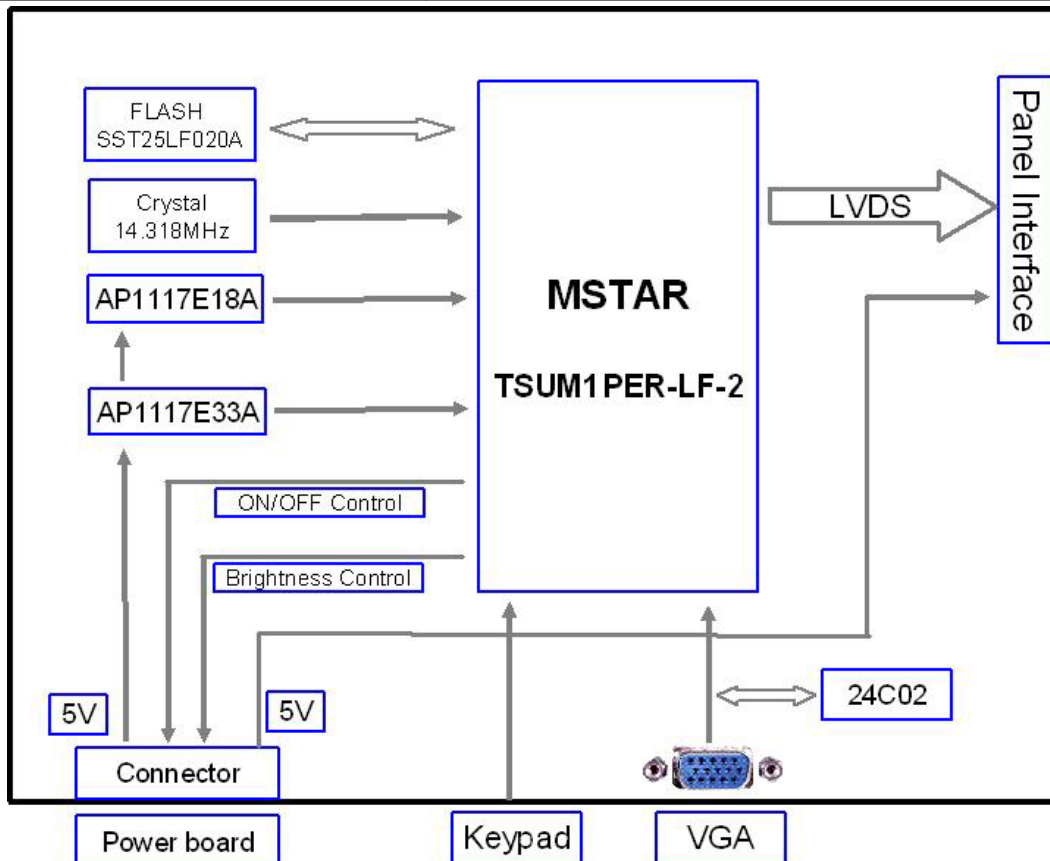
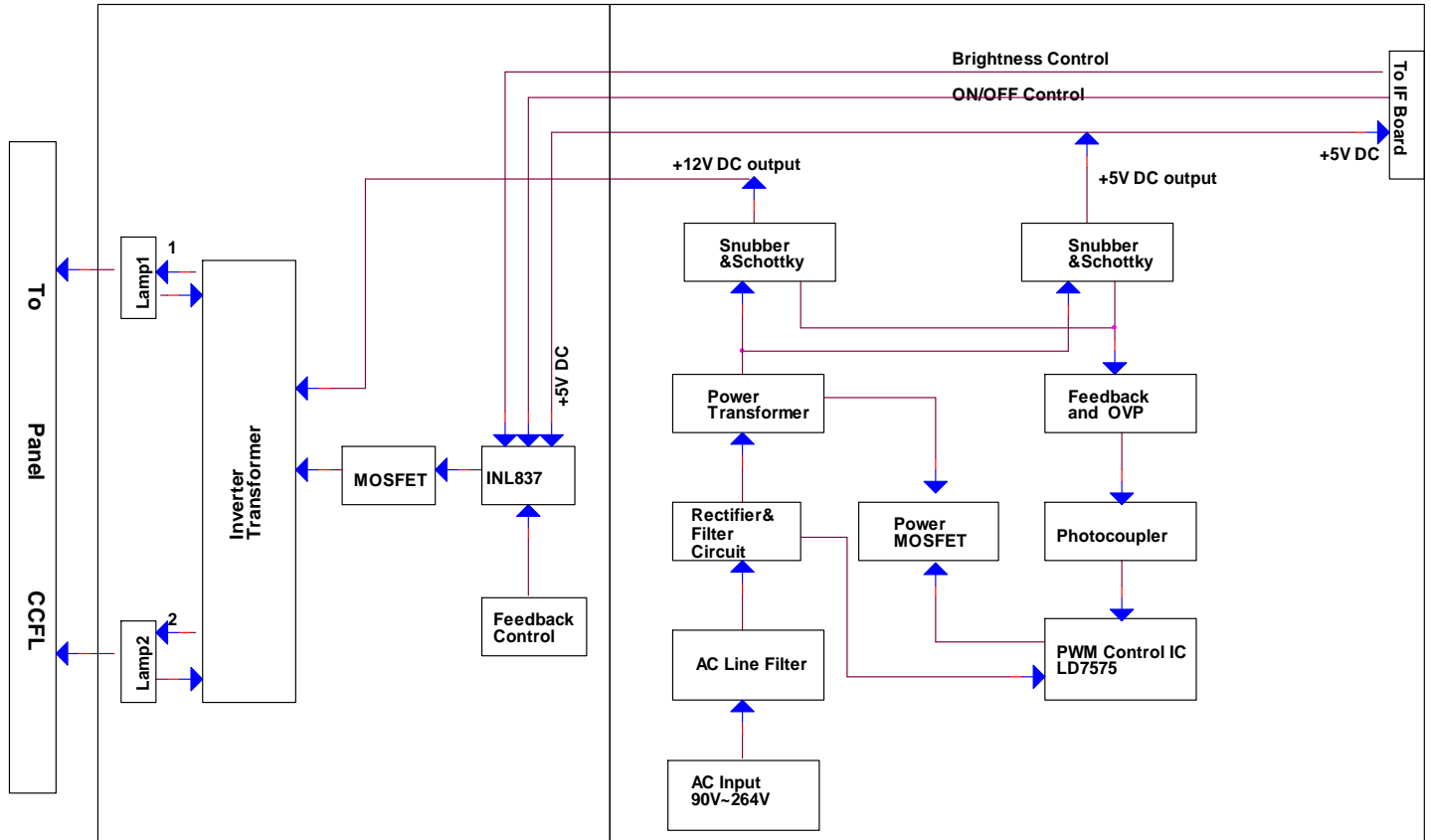

Fig.1

a DC voltage to PID (pin5).

The striking frequency is determined by R12 and C9 connected to Pin 13(CT) and R6 connected to RSTR (Pin6). The operating frequency is determined by R12 and C9 connected to Pin 13(CT) and R7 connected to RT (pin7).

DRV1 and DRV2 of U1 are used to drive U2. DRV1 and DRV2 are controlled by build-in PWM IC. U2 is switch which has two build-in IGBTs.

2.1.2) Output Circuit and Protection Circuit :(fig.3)

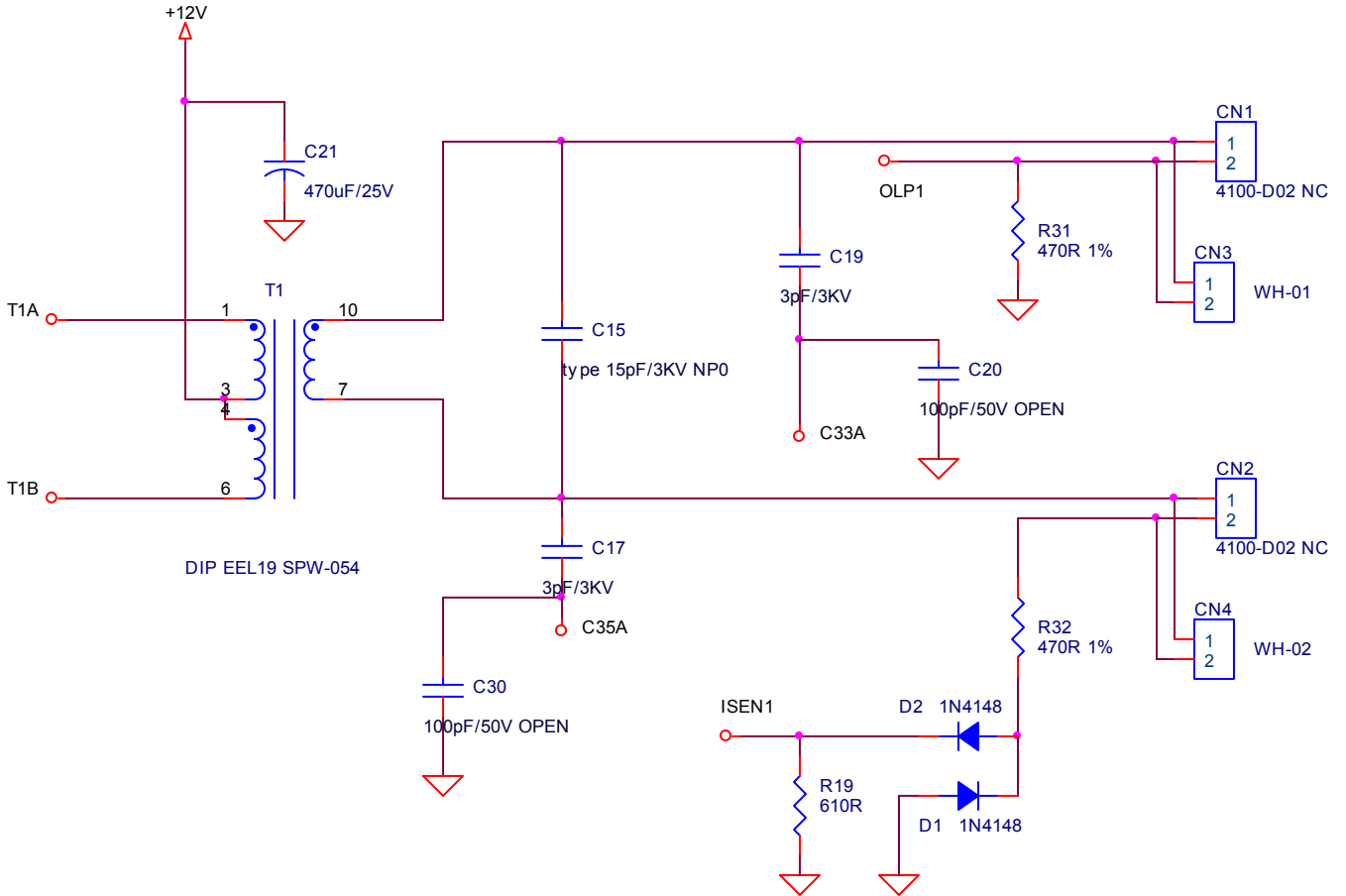

fig.3

The transformer (T1) secondary winding leakage inductance and output capacitance (C15) forms a lower pass filter, which converts the square-wave driving signal into a sinusoidal output voltage signal for CCFL.

The over-voltage protection feature is implemented by using an external capacitor divider (C17/C19) to sense the output voltage. The divide-down voltage signal is sent to the IC Pin9 (VSEN), thus regulating the output voltage.

The voltage signal on negative pole of D2 sensed through R19 comes to Pin4 of U1 (ISEN). The CCFL current detected at resistor R19 is converted to a voltage level and input to the ISEN pin. C6 is used to dump noise. Once the CCFLs are ignited and current is sensed through resistor R19, capacitor C6 performs the loop compensation function. The voltage at IC pin12 (SSTCMP) controls the drive duty cycle of the power MOSFETs to regulate the CCFL current.

If a CCFL is removed, fails or damaged during normal operation, CCFL current is no longer sensed and the voltage on ISEN pin drops. Once the voltage at the ISEN pin is less than the lamp "on" threshold, the shutdown timer is activated. The IC maintains the output voltage for approximately 2-3seconds and once the timer expires, the IC will shutdown. To restart the IC, either toggle the SST_CMP pin or recycle the power on the VDDA pin.

2.2 Power PWM circuit

2.2.1) Block diagram :(fig.4)

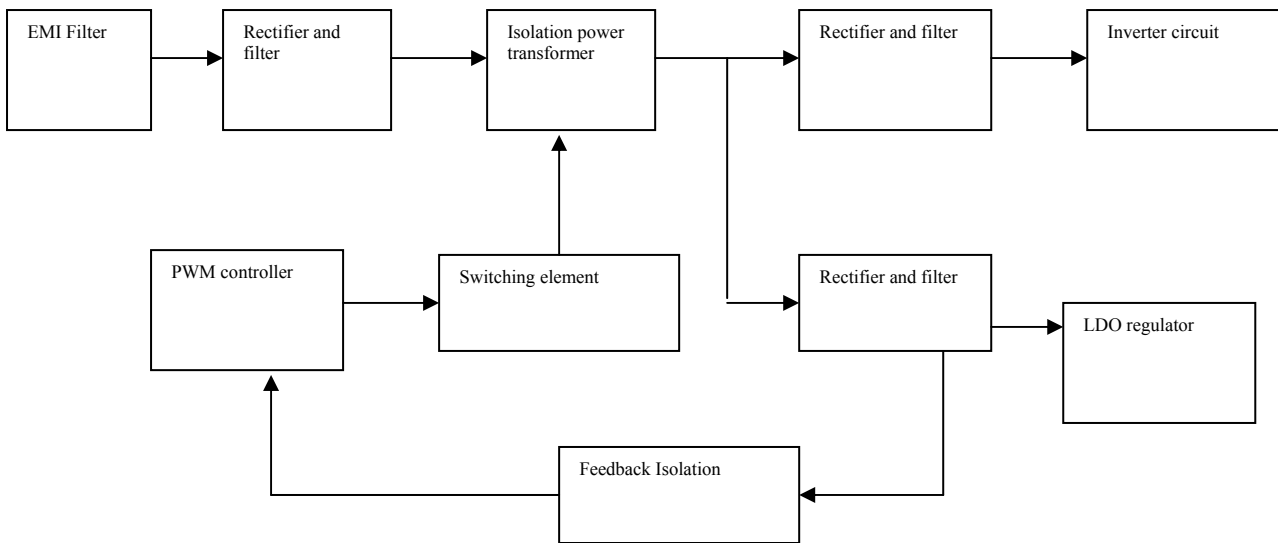

Fig.4

2.2.2) AC Input and EMI Filter :(fig.5)

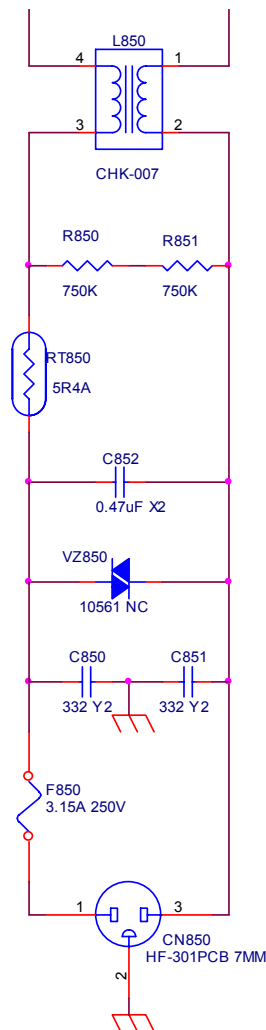

fig.5

CN850 is a connector for connecting AC Power. F850 is a fuse to protect all the circuit AC. Input voltage is from 90V to 264V. R850 and R851 are joined between two inputting main circuit to prevent man from shock. L850 is used to clear up low frequency wave. C850 and C851 are

used to discharge the waves that L850 produced. High frequency waves are damped by C852.

2.2.3) High Voltage to Low Voltage Control Circuit :(fig.6)

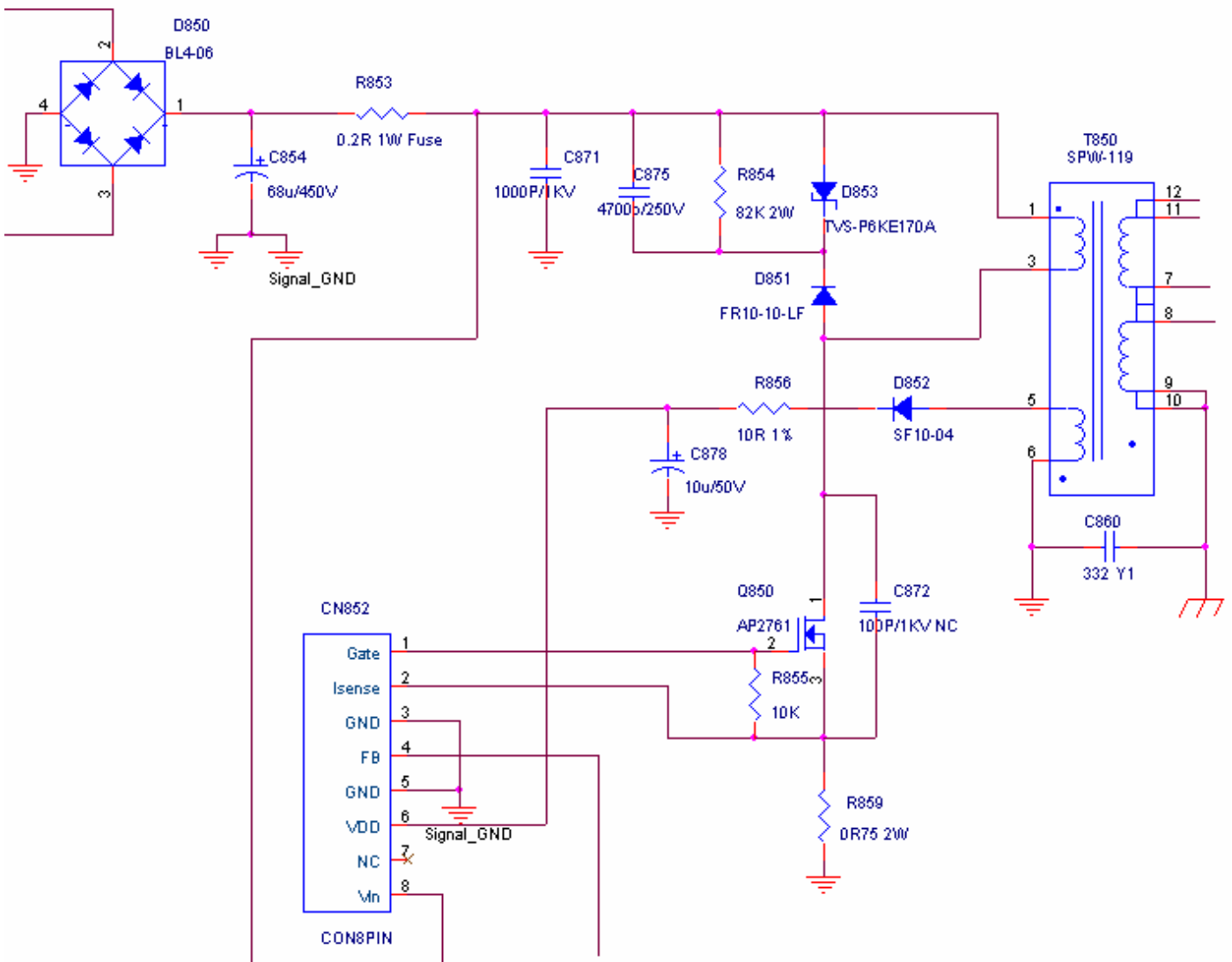

fig.6

D850 is a rectifier in which there are 4 build-in diodes, inverting AC to DC.

C854 is used to smooth the wave from rectifier. R853 is a fuse resistor to protect the following circuit when inrush current is too large. U850 is a highly integrated PWM controller. During the startup, a high-voltage current source sinks current from the bulk capacitor to provide the startup current as well as charge the Vcc capacitor C878, during the startup transient, the Vcc is lower than the UVLO threshold thus the current source is on to supply a current with 1mA. Meanwhile, the Vcc supply current is as low as 100uA thus most of the HV current is utilized to charge the Vcc capacitor.

Whenever the Vcc voltage is higher than UVLO (on) to power on the LD7575 and further to deliver the gate driver signal, the high-voltage current source is off and the supply current is provided from the auxiliary winding of the transformer (T850). Pin8 (GATE) of U850 will output square wave to drive Q850, and then the main current flow HV to GND by passing through T850, Q850. Because of the change of current flow, wires in the other side of T850 will induct current.

When the sense voltage across the sense resistor R859, reaches the threshold voltage around 0.85V, the output GATE drive will be turned off. Every time when the output of power supply is shorted or over loaded, the FB voltage will increase, the build-in PWM output will then be turned off. Both will prevent the power supply from being overheated under over loading condition. The PWM duty cycle is determined by this current sense signal and VFB, the feedback voltage. When the voltage on sense pin reaches $V_{comp} = (V_{FB}-1.0)/3$, a switch cycle will be terminated immediately. Vcomp is internally clamped to a variable voltage around 0.85 V for output power limit.

When Q850 are turned off, the main current flow will be consumed through D851, C875, R854 and D853. This will prevent Q850 from being damaged under large current impulse and voltage spike.

2.2.4) DC 12V and 5V Output Circuit and Feedback circuit :(fig.7)

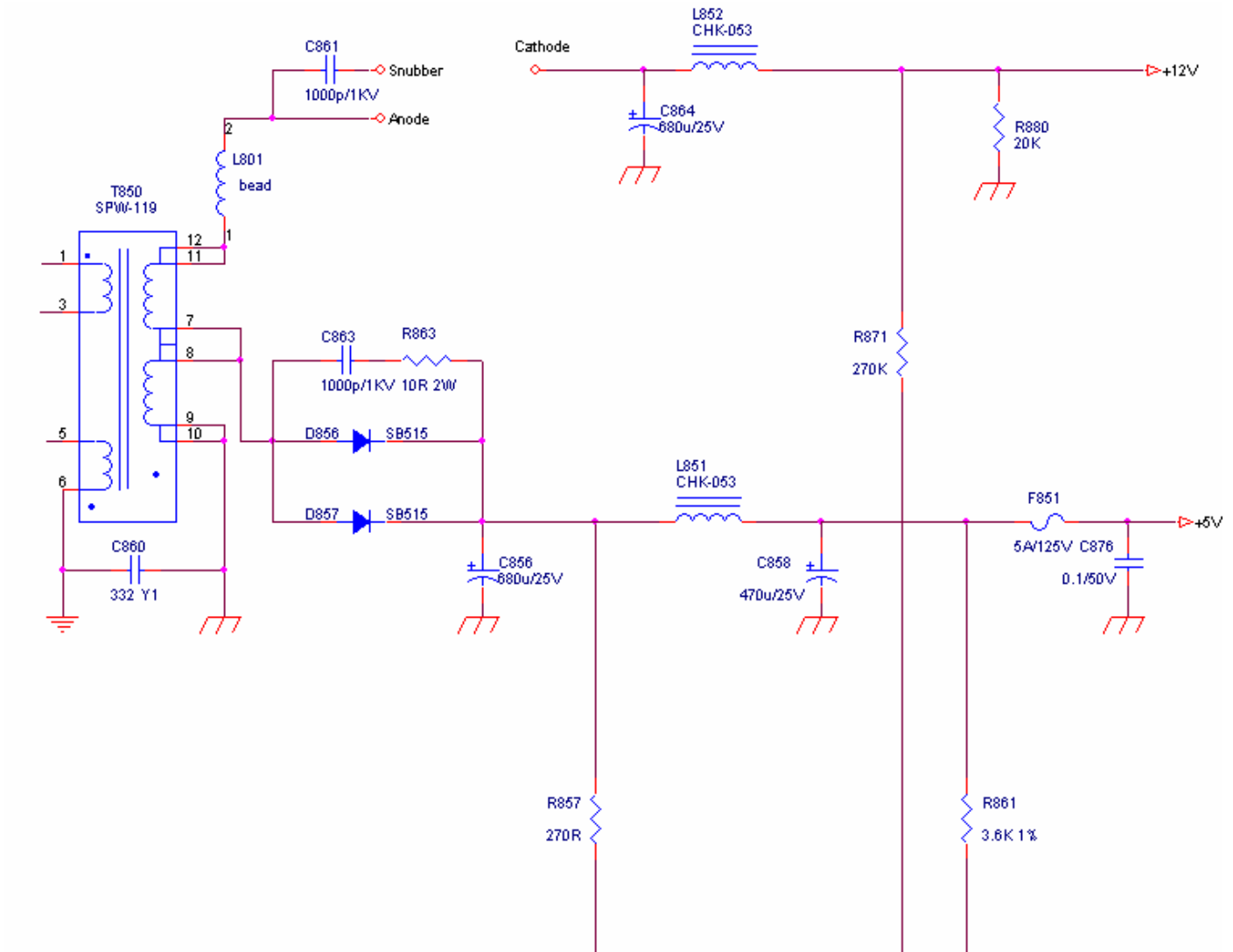

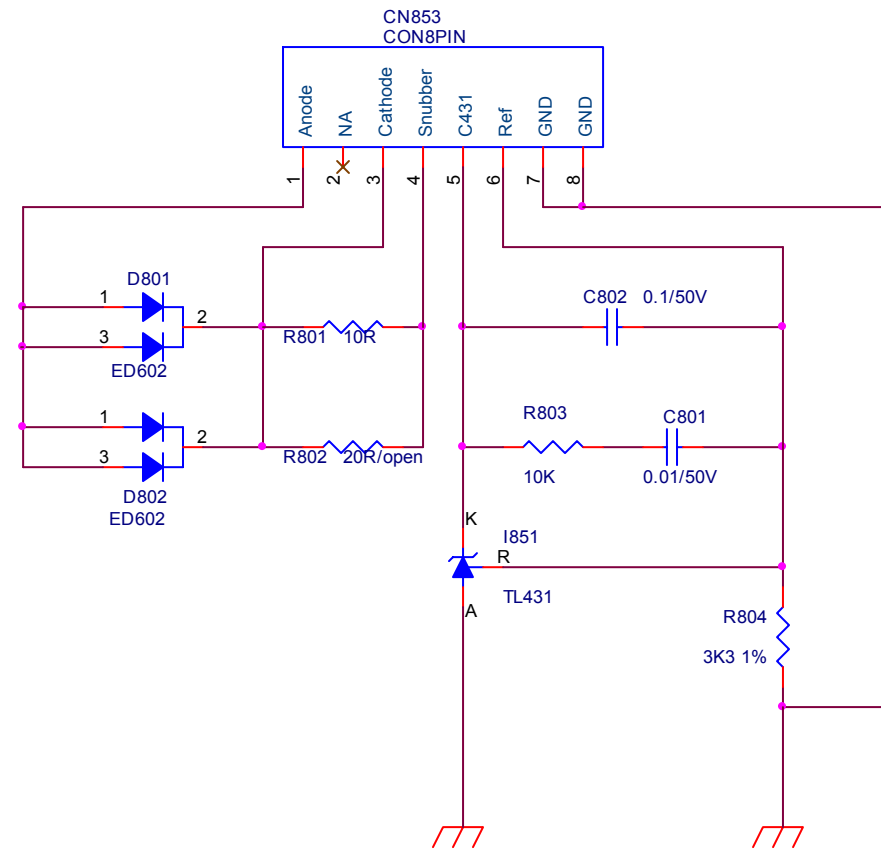

fig.7

D801 is used to rectify the inducted current. R801 and C861 are used to store energy when current is reversed. The parts including C864 and L852 are used to smooth the current waves that are from D801, and then 12V voltage is supplied.

D856 is used to rectify the inducted current. R863 and C863 are used to store energy when current is reversed. The parts including C856, C858, C876 and L851 are used to smooth the current waves that are from D856, and then 5V voltage is supplied.

12V and 5V supply voltage feed back to PWM controller U850 via R861, R871, R804 and I850. R803, C801 and C802 used to control respond time.

2.3 I/F Board Circuit (see the Attachment 2- Schematic)

2.3.1 RGB CAPTURE

- Signal RED, GREEN, BLUE input through CN102 #1, #2, #3, Stop DC via C113, C114 and C115, and then enter into U105 (TSUM1PER-LF-2) analog input PIN #13, #10, #8, and then TSUM1PER-LF-2 deals with signal internally. D103, D104, D105 are ESD protector to prevent U105 from ESD.
- Signal DDC_SCL (series clock) inputs via CN102#15, and then passes through ZD106 for ESD protection, goes into EDID EEPROM IC U103 #6.
- Signal DDC_SDA (series data) inputs via CN102#12, and then passes through ZD103 for ESD protection, goes into EDID EEPROM IC U103 #5.
- Signal TTL vertical sync. (Vsync) inputs via CN102 #14, and then clamped by ZD105 Zener, passes through R134, and then goes into IC U105 (TSUM1PER-LF-2) #17.
- Signal TTL horizontal sync. (Hsync) inputs via CN102 #13, and then clamped by ZD104 Zener, passes through FB101 & R133, and then goes into IC U105 (TSUM1PER-LF-2) #16.
- CN102#5 is defined as cable detect pin, this detector realize via R121 and U105#64, and D102 is ESD protector.
- U103 +5V is supplied by PC via CN102#9 with D106 and ZD102 for ESD protection, or supplied by Monitor self via D104.
- U103 is an EEPROM IC which is memory and EDID data saved in it.

2.3.2 Buttons Control

- Button “Power” on front bezel connects to U105 (TSUM1PER-LF-2) #58 through CN104 #1, U105 #58 is defined as power on/off.
- Button “(” on front bezel connects to U105 (TSUM1PER-LF-2) #57 through CN104 #5, U105#57 Voltage is defined as “Plus”.
- Button “)” on front bezel connects to U105 (TSUM1PER-LF-2) #57 through CN104 #5, U105 #57 Voltage is defined as “Minus”.
- Button “Menu” on front bezel connects to U105 (TSUM1PER-LF-2) #63 through CN104 #6; U105 #63 Voltages is defined as “Menu”.
- Button “ENTER” on front bezel connects to U105 (TSUM1PER-LF-2) #59 through CN104 #4, U105 #59 Voltage is defined as “ENTER”.
- LED Indicator on Front Bezel
 - a. When press button “power”, U105 (TSUM1PER-LF-2) #60 be send in low Voltage, make Q107#3 sends out high Voltage , and then to CN104#3 on keypad, LED Blue on.
 - b. When in “Suspend” mode, U105 (TSUM1PER-LF-2) #61 sends out a low Voltage, make Q108#3 sends out high Voltage and then to CN104 #2 on keypad, LED Amber ON.

2.3.3 MATAR CHIP U105 (TSUM1PER-LF-2)

- U105 (TSUM1PER-LF-2) #33~#40 output 8 bit even and #41~#50 output 8 bit odd LVDS digital data to panel control circuit through CN106.
- U105 (TSUM1PER-LF-2) #28 output PPWR ”H” potential to make Q104 conducted, and then make Q101 conducted, +5V flow to CN103#1~#3 as Panel Vdd .
- U105 (TSUM1PER-LF-2) #55 output CCFL_ ON/OFF”L” potential to control Inverter on/off.
- U105 (TSUM1PER-LF-2) #56 outputs Brightness “PWM” signals to control CCFL brightness.
- TCLK by Crystal 14.318MHz input to U105 (TSUM1PER-LF-2) #2.
- U105 (TSUM1PER-LF-2) #54 is RESET signals input pin

Please refer to TSUM1PER-LF-2 Pin Assignments table in page

2.3.4 Regulator Circuit

- +5V is from switching mode power supply for panel
- +3.3V is generated from Regulator U101 which is supplied by+5V through C104 filtering, C102 is 3.3V output filter ,the output 3.3V supplies toU105, U108,U106, U102.
- +1.8V is generated from Regulator U102 which is supplied byU101-3.3V through C106 filtering.The1.8V via FB105 supplies to U105.

3. FACTORY PRESET TIMING TABLE

Standard	Resolution	Horizontal Frequency (KHz)	Vertical Frequency (Hz)
VESA	640 x 480	31.469	59.940
	640 x 480	37.500	75.000
	800 x 600	37.879	60.317
	800 x 600	46.875	75.000
	1024 x 768	48.363	60.004
	1024 x 768	60.023	75.029
	1152x864	67.500	75.000
	1280x1024	48.483	60.042
	1280x1024	60.087	75.034
1440x900	55.935	59.887	
IBM DOS	720 x 400	31.469	70.087

4. Power On/Off Sequency

Hardware power On/Off

When power cord plug into AC socket, Power provides 16V and DC_5V.

DC_5V is main voltage for panel and Regulator U101.

DC_3.3V is coming from Regulator U101; DC_3.3v is main voltage for U105. When DC_3.3V input to U105 and U105 reset circuit active, U105 all registers will be set to default, that means finish hardware power on.

When pull out power cord from AC socket, the system shut down instantly for no supply

Software power On/Off

- When press power key, U105 #58 receives low pulse, then (TSM1PER-LF-2) U105 will be wake up and send control signals(at 55,28pin) to on CCFL and switch 5.0v to panel module, at the same time,U105 make the VGAcable input signal source display normal on panel if the VGAcable input signal is active
- If power ON, U105 #60 (LED_Blue) will send out low potential, and then LED Blue on.
- If power saveing, U105 #61 (LED_Amber) will send out low potential, and then LED Amber on.
- If power ON or power saving, when press power key, U105 #55 receives low pulse, then U105 will be sleeping and turn off backlight, at the same time, the panel will lose +5V.

The Panel_Vcc, Backlight_En, CLK/DATA output to panel will follow the following sequency.

Power supply for panel+5V V_{DD}

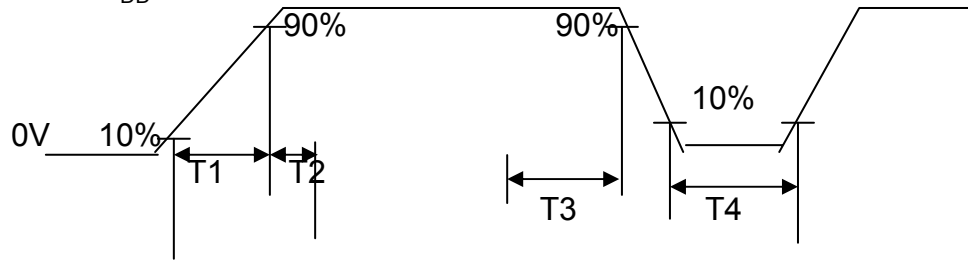

Signals
(Digital RGB, HS, VS, DE, CLOCK)

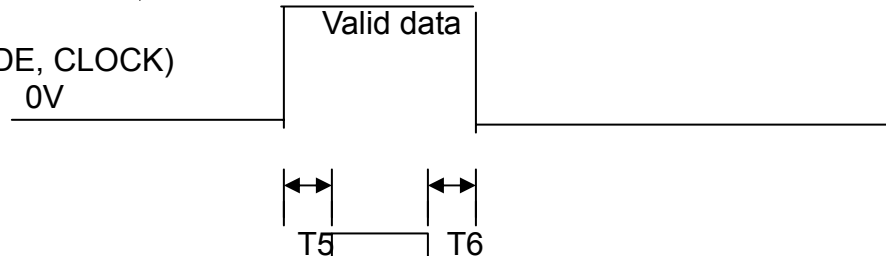

Power supply for backlight

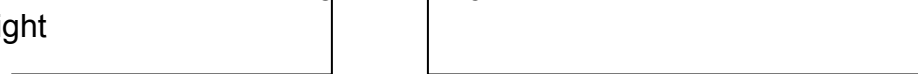

	T1 (ms)	T2 (ms)	T3 (ms)	T4 (ms)	T5 (ms)	T6 (ms)
SPEC (HSD)	0.5~10	0~50	0~50	>200	>200	>200
SPEC (LPL)	0.5~10	0.01~50	0.01~50	>500	>500	>200

5. D-SUB Connector Pin Assignment

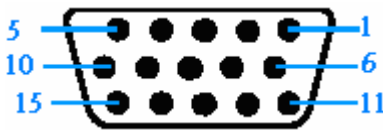

Pin	Symbol	Pin	Symbol	Pin	Symbol
1	Red	6	Red_GND	11	GND
2	Green	7	Green_GND	12	DDC_SDA
3	Blue	8	Blue_GND	13	Hsync
4	GND	9	PC+5V	14	Vsync
5	Cable Detect	10	GND	15	DDC_SCL

6. AC input connector Pin Assignment

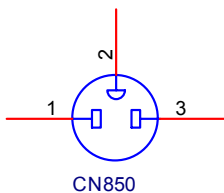

Pin	Symbol	Description
1	Line	AC Line(V _{in} =100 to 240 V _{rms} ,50/60Hz)
2	GND	GND
3	Neutral	AC Line(V _{in} =100 to 240 V _{rms} ,50/60Hz)

7. Inner Connector Pin Assignment

7.1 CN103 (Connect M/B to Panel,)

Pin	Symbol	Description
1	Panel_Vcc	Panel power supply (typ.5.0V)
2	Panel_Vcc	Panel power supply (typ. 5.0V)
3	Panel_Vcc	Panel power supply (typ. 5.0V)
4	NC	
5	NC	

6	NC	
7	GND_LVDS	LVDS Ground
8	RXE3+	LVDS signal of even channel 3(-)
9	RXE3-	LVDS signal of even channel 3(+)
10	RXEC+	LVDS signal of even channel clock (+)
11	RXEC-	LVDS signal of even channel clock (-)
12	RXE2+	LVDS signal of even channel 2(+)
13	RXE2-	LVDS signal of even channel 2(-)
14	GND_LVDS	LVDS Ground
15	RXE1+	LVDS signal of even channel 1(+)
16	RXE1-	LVDS signal of even channel 1(-)
17	GND_LVDS	LVDS Ground
18	RXE0+	LVDS signal of odd channel 0(+)
19	RXE0-	LVDS signal of odd channel 0(-)
20	RXO3+	LVDS signal of odd channel 3(+)
21	RXO3-	LVDS signal of odd channel 3(-)
22	RXOC+	LVDS signal of even channel clock (+)
23	RXOC-	LVDS signal of even channel clock (-)
24	GND_LVDS	LVDS Ground
25	RXO2+	LVDS signal of even channel 2(+)
26	RXO2-	LVDS signal of even channel 2(-)
27	RXO1+	LVDS signal of even channel 1(+)
28	RXO1-	LVDS signal of even channel 1(-)
29	RXO0+	LVDS signal of odd channel 0(+)
30	RXO0-	LVDS signal of odd channel 0(-)

7.2 CN1, CN2, CN3, CN4 (Connect to Panel Backlight,)

Pin	Symbol	Description
1	HV	High voltage for lamp
2	LV	Low voltage for lamp

7.3 CN104 (Connect to keypad, WAFER2*4P or compatible connector)

Pin	Symbol	Description
1	POWER	OSD "POWER" control
2	LED Amber	LED amber on/off control
3	LED Blue	LED Blue on/off control
4	ENTER	OSD "ENTER" control
5	PLUS/MINUS	OSD "+/-" control and "AUTO/Brightness" adjustable hot key
6	MENU	OSD "MENU" control
7	GND	Ground
8	GND	Ground

8. Key Parts Pin Assignments

8.1 U105(TSUM1PER-LF-2)

Analog Interface

Pin Name	Pin Type	Function	Pin
HSYNC0	Schmitt Trigger Input w/ 5V-tolerant	Analog HSYNC Input	16
VSYNC0	Schmitt Trigger Input w/ 5V-tolerant	Analog VSYNC Input	17
REFP		Internal ADC Top De-Coupling Pin	15
REFM		Internal ADC Bottom De-Coupling Pin	14
RIN0P	Analog Input	Analog Red Input	13
RIN0M	Analog Input	Reference Ground for Analog Red Input	12
SOGIN0	Analog Input	Sync-On-Green Input	11
GIN0P	Analog Input	Analog Green Input	10
GIN0M	Analog Input	Reference Ground for Analog Green Input	9
BIN0P	Analog Input	Analog Blue Input	8
BIN0M	Analog Input	Reference Ground for Analog Blue Input	7
REXT		External Resistor 390 ohm to AVDD_33	4

Serial Flash Interface

Pin Name	Pin Type	Function	Pin
SDO	Input w/ 5V-tolerant	SPI Flash Serial Data Output	21
CSZ	Output	SPI Flash Chip Select	22
SCK	Output	SPI Flash Serial Clock	23
SDI	Output	SPI Flash Serial Data Input	24

LVDS Interface

Pin Name	Pin Type	Function	Pin
LVA0M	Output	LVDS A-Link Channel 0 Negative Data Output	40
LVA0P	Output	LVDS A-Link Channel 0 Positive Data Output	39
LVA1M	Output	LVDS A-Link Channel 1 Negative Data Output	38
LVA1P	Output	LVDS A-Link Channel 1 Positive Data Output	37
LVA2M	Output	LVDS A-Link Channel 2 Negative Data Output	36
LVA2P	Output	LVDS A-Link Channel 2 Positive Data Output	35
LVA3M	Output	LVDS A-Link Channel 3 Negative Data Output	34
LVA3P	Output	LVDS A-Link Channel 3 Positive Data Output	33
LVB0M	Output	LVDS B-Link Channel 0 Negative Data Output	50

Pin Name	Pin Type	Function	Pin
LVB0P	Output	LVDS B-Link Channel 0 Positive Data Output	49
LVB1M	Output	LVDS B-Link Channel 1 Negative Data Output	48
LVB1P	Output	LVDS B-Link Channel 1 Positive Data Output	47
LVB2M	Output	LVDS B-Link Channel 2 Negative Data Output	46
LVB2P	Output	LVDS B-Link Channel 2 Positive Data Output	45
LVB3M	Output	LVDS B-Link Channel 3 Negative Data Output	42
LVB3P	Output	LVDS B-Link Channel 3 Positive Data Output	41
LVBCKM	Output	LVDS B-Link Negative Clock Output	44
LVBCKP	Output	LVDS B-Link Positive Clock Output	43

GPIO Interface

Pin Name	Pin Type	Function	Pin
GPIO_P22 / PWM0	I/O w/ 5V-tolerant	General Purpose Input/Output / Pulse Width Modulation Output; 4mA driving strength	20
GPIO_P24 / PWM2	I/O w/ 5V-tolerant	General Purpose Input/Output / Pulse Width Modulation Output; 4mA driving strength	27
GPIO_P45 / PWM1	I/O w/ 5V-tolerant	General Purpose Input/Output / Pulse Width Modulation Output; 4mA driving strength	28
GPIO_P25	I/O w/ 5V-tolerant	General Purpose Input/Output; 4mA driving strength	55
GPIO_P27 / PWM3	I/O w/ 5V-tolerant	General Purpose Input/Output / Pulse Width Modulation Output; 4mA driving strength	56
GPIO_P00 / SAR0	I/O w/ 5V-tolerant	General Purpose Input/Output / SAR ADC Input; 4mA driving strength	57
GPIO_P01 / SAR1	I/O w/ 5V-tolerant	General Purpose Input/Output / SAR ADC Input; 4mA driving strength	58
GPIO_P02 / SAR2	I/O w/ 5V-tolerant	General Purpose Input/Output / SAR ADC Input; 4mA driving strength	59
GPIO_P07	I/O w/ 5V-tolerant	General Purpose Input/Output; 6/12mA programmable driving strength	60
GPIO_P15	I/O w/ 5V-tolerant	General Purpose Input/Output; 6/12mA programmable driving strength	61
GPIO_P16 / PWM1	I/O w/ 5V-tolerant	General Purpose Input/Output / Pulse Width Modulation Output; 4mA driving strength	62
GPIO_P12	I/O w/ 5V-tolerant	General Purpose Input/Output; 4mA driving strength	63
GPIO_P13	I/O w/ 5V-tolerant	General Purpose Input/Output; 4mA driving strength	64

Misc. Interface

Pin Name	Pin Type	Function	Pin
VCTRL	Output	Regulator Control	52
RST	Input w/ 5V-tolerant	Chip Reset; High Reset	54
MODE	Input	Chip Configuration Input; 10K ohm pull-low for normal operation	32
DDCA_SDA / RS232_TX	I/O w/ 5V-tolerant	DDC Data for Analog Interface / UART Transmitter / General Purpose Input/Output; 4mA driving strength	18
DDCA_SCL / RS232_RX	I/O w/ 5V-tolerant	DDC Clock for Analog Interface / UART Receiver / General Purpose Input/Output; 4mA driving strength	19
I2C_MDA / GPIO_P11	I/O w/ 5V-tolerant	I2C Master Data / General Purpose Input/Output ; 4mA driving strength	25
I2C_MCL / GPIO_P10	I/O w/ 5V-tolerant	I2C Master Clock / General Purpose Input/Output; 4mA driving strength	26
XIN	Crystal Oscillator Input	Xin	2
XOUT	Crystal Oscillator Output	Xout	1

Power Pins

Pin Name	Pin Type	Function	Pin
AVDD_33	3.3V Power	Analog Power	6
VDDP	3.3V Power	Digital Output Power	51
VDDC	1.8V Power	Digital Core Power	30, 53
GND	Ground	Ground	3, 5, 29

8.2U108 (Serial Flash)

Pin	Symbol	I/O	Description
1	CE#	I	The device is enabled by a high to low transition on CE#. CE# must remain low for the duration of any command sequence.
2	SO	I/O	To transfer commands, addresses, or data serially into the device.
3	WP#	I/O	The write protect (WP#) pin is used to enable/disable BPL bit in the status register.
4	VSS	G	Connect ground
5	SI	I/O	To transfer commands, addresses, or data serially into the device input are latched on the rising edge of the serial clock.
6	SCK	I/O	To provide the timing of serial interface. Commands, addresses, or input data are latched on the rising edge of the clock input, while output data is shifted out on the Falling edge of the clock input.
7	HOLD	I/O	To temporarily stop serial communication with SPI flash memory without resetting the device.

8	VDD	P	To provide power supply.
---	-----	---	--------------------------

8.3 U850 (LD7575, PWM Power Controller)

Pin	Symbol	I/O	Description
1	RT		To program the switching frequency. By connecting a resistor to set the switching frequency.
2	COMP	I	Voltage feedback pin. The PWM duty cycle is controlled by COMP.
3	CS	I	Current sense for over current protection
4	GND		Ground
5	OUT	O	PWM output
6	VCC	I	Power supply
7	NC		Unconnected
8	HV	I	To provide the startup current for the controller.

8.4 U1 (INL837, CCFL Inverter controller IC)

Pin	Symbol	I/O	Description
1	DRV1	O	Drive output1
2	VDDA	I	Supply voltage input
3	DIM	I	Internal LPWM dimming or external PWM pulse input for dimming function
4	ISEN	I	Current sense feedback
5	PID	I	Analog dim input
6	RSTR	I	Resistor to set striking frequency
7	RT	I	Resistor to set operating frequency compensation range
8	ENA	I	ON/OFF control of IC
9	VSEN	I	Voltage sense
10	OVPT	I	Over-voltage/over-current protecting threshold setting
11	LCT	I	Timing capacitor to set internal PWM dimming frequency
12	SSTCMP	I	Capacitor for soft start time and loop compensation
13	CT	I	Timing resistor and capacitor for operation and striking frequency
14	TIMER	I	Timing capacitor to set striking time and shutdown delay time
15	GNDA	I	Ground
16	DRV2	O	Drive output2

Chapter 4- Disassembly & Assembly

1. Exploded Diagram

8

7

6

5

4

3

2

1

A

B

C

D

E

F

MODIFY HISTORY			
ZONE	REV	DESCRIPTION	DATE APPROVED

NO.	Designation	Identification NO. (QTY)	Remark	Designation	Identification NO. (QTY)	Remark
1-1	FRONT BEZEL LE17M6	5010102200R	1			
1-2	SUB-BUTTON LE17M6	7500202000R	1			
1-3	POWER BUTTON LE17M6	50112011010R	1			
1-4	POWER BUTTON LE17M6	50112011010R	1			
1-5	CHASSIS-MAT LE17M6	5050421000R	1			
1-6	CHASSIS-MAT LE17M6	5050421000R	1			
1-7	TYPE ACE 86x20mm LE17M6	50503001700R	1			
2	ASST. BACK COVER LE17M6	7140302100R	1			
2-1	BACK COVER LE17M6	5010202600R	1			
2-2	RESISTOR LE17M6	5022101000R	1			
3	CHASSIS FOR LCD PANEL LE17M6	5010010400R	1			
3-1	CHASSIS FOR LCD PANEL LE17M6	5010010400R	1			
3-2	SHIELD BHT	5020014000R	2			
3-3	ASST. CHASSIS FOR LCD PANEL LE17M6	5010010400R	1			
3-4	CHASSIS FOR LCD PANEL LE17M6	5010010400R	1			
3-5	SHIELD BHT	5020014000R	2			

ITEM	PART NO.	MATERIAL (THICKNESS/COLOR)	FINISH	REMARK
	NAME	DATE		
	Steve Meng	2008.07.18		
	DESIGNAL	TITLE		
		LE17M6 Exploded Drawing		
REV.	A	MATERIAL		
		LE17M6		
APPROVED		SCALE		
		1:1		
		UNITS: mm		
		SHEET 1 of 1		
		FORM NO.		
		LMR04544018G		

2. E1709W Disassembly Block

LE19D5 DISASSEMBLY BLOCK

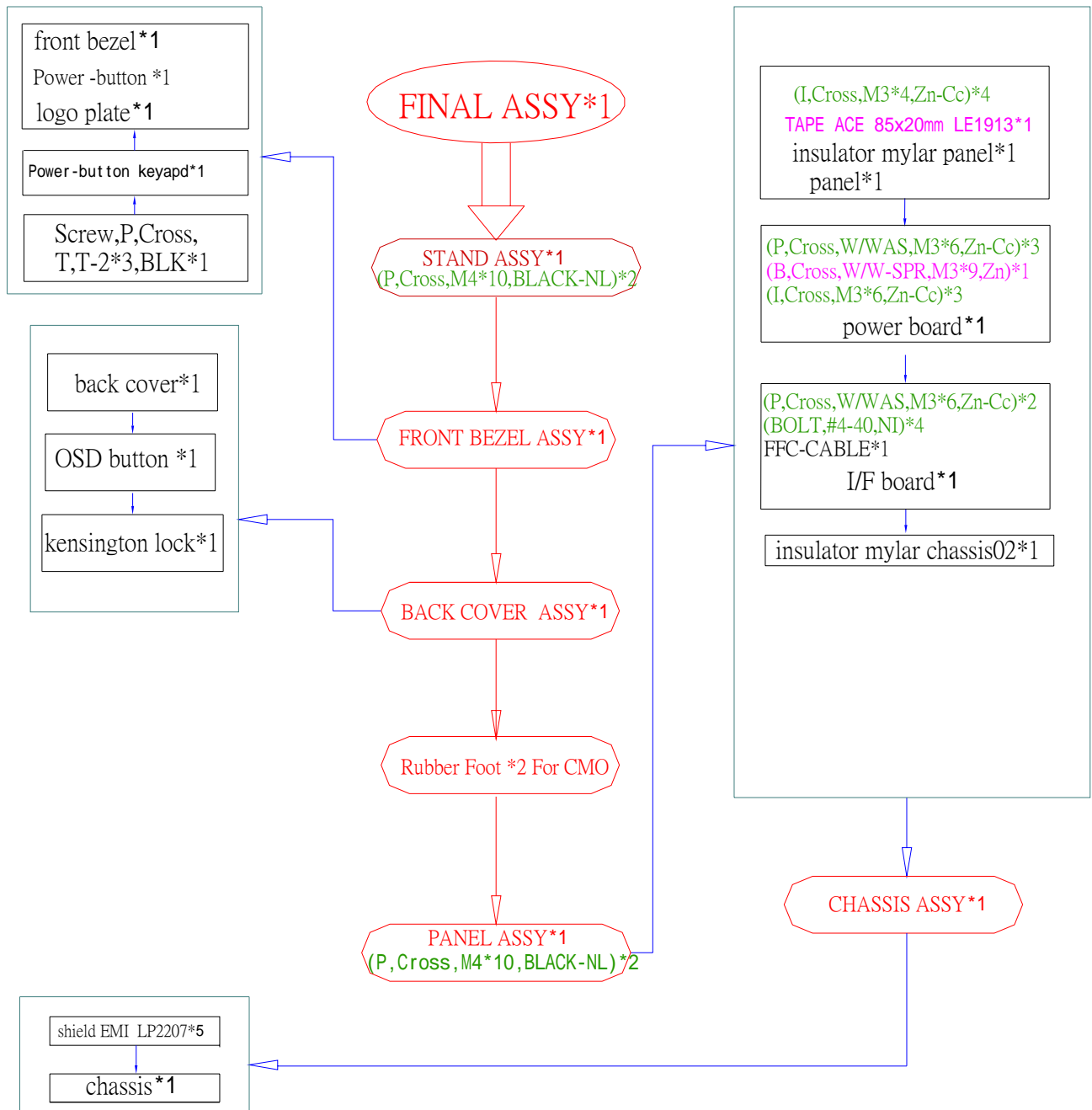

Note: 1. The arrows point out the direction of disassembly.

3. E1709W Assembly Block

LE17M6 ASSEMBLY BLOCK

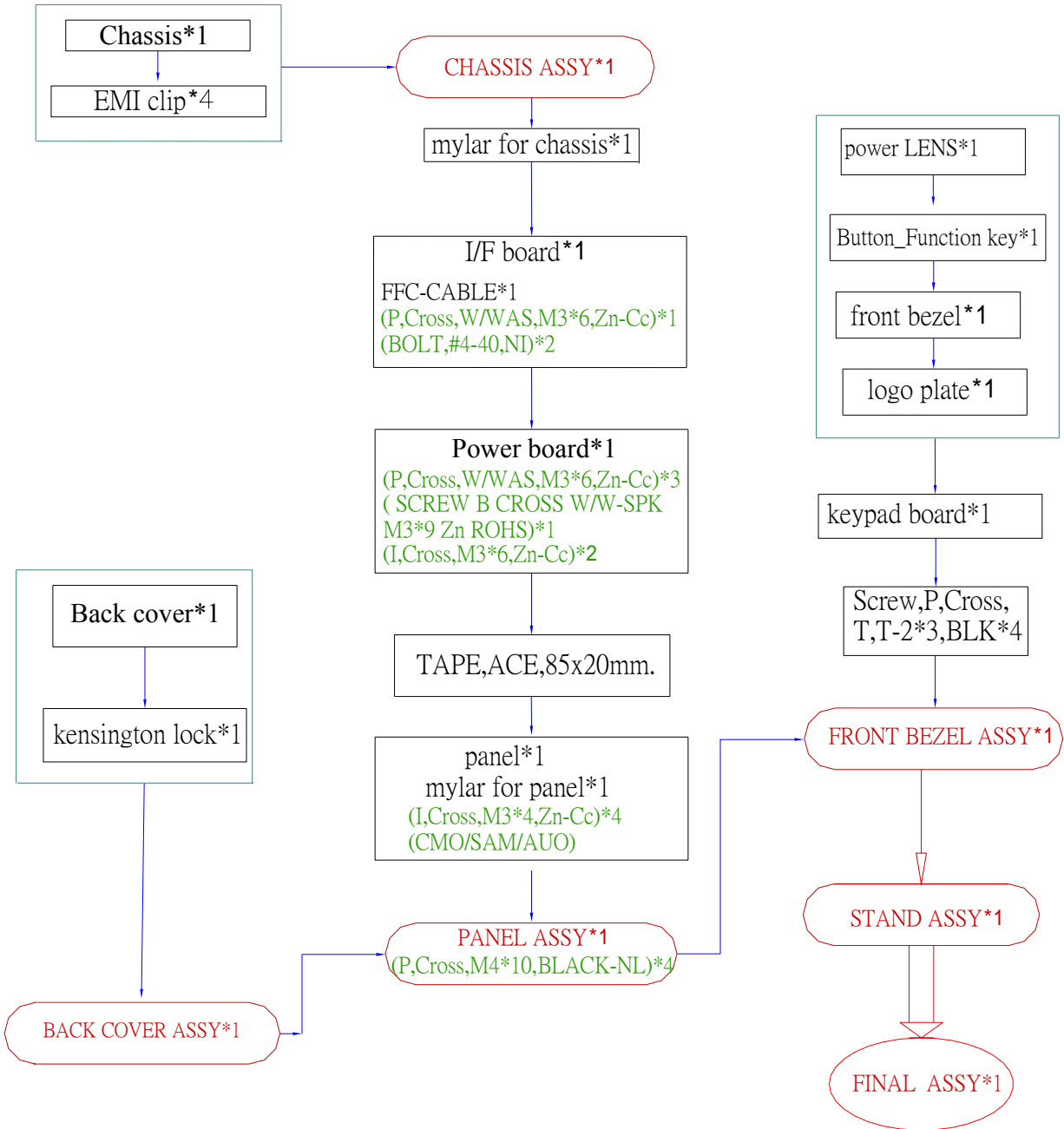

Note: 1. The arrows point out the direction of assembly

Chapter 5- TEST AND ADJUSTMENT

1. Function key Definitions

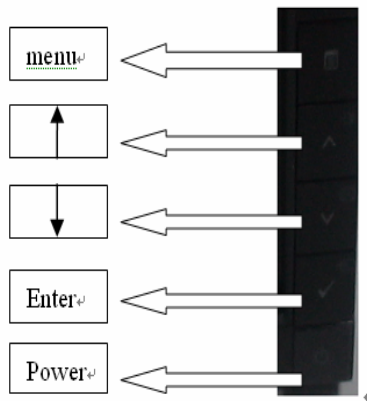

Hot Key Operation

FUNCTION	HOT KEY OPERATION					DESCRIPTION
	MENU	↑	↓	ENTER	POWER	
FACTORY MODE	•	•			ON	Press [↑] & [MENU] at the same time, and then press [POWER] for DC power on. Press the ↑ key to enter factory menu
Brightness& Contrast		•				To show the Brightness& Contrast menu
AUTO ADJUST			•			Execute the AUTO ADJUST function

Power Switch with power LED indicator	Power: On/Off, includes power indicator and Power ICON Blue- Active On Amber- DPMS
Front Panel Controls	1.Menu: Call out OSD Menu and choose 2. (↑): symbol molded into button, calls out brightness/Contrast, move down the highlight bar. 3. (↓)symbol molded into button, move up the highlight bar
Hot Key Function	Automatic adjust: Directly press “↓” Brightness/Contrast Icon: Directly press “↑”
Factory Modes Keys Function	Auto Color Balance Purpose: Automatically calibrate chip ADC parameter by using chip internal DAC. Process: If we want to do “Auto Color Balance” again, please confirm the following steps. 1) Connect the VGA cable with the standard video pattern generator and display the pattern with blackest and whitest colors. 2) Press “Power Key”, to power off the monitor. 3) Press “Menu Key” and “↑” simultaneously, and then press “Power Key” to power on the monitor. 4) Press “↑” to enter factory menu 5) Execute Auto Color item. 6) After the “Auto Color Balance” process finished, go back to Main Menu, and Enter Factory Reset Menu, Then press “Factory Reset” to exit Factory Menu.

OSD Control

First	Second	Third	Default	VGA Input
Brightness	Brightness		75	Yes
	Contrast		75	Yes
Auto Adjust	Press v to adjust the screen automatically			Yes
Color Settings	Input Color Format	RGB	RGB	Yes
		YPbPr		
	Mode Selection	Graphics	Graphics	
		Video		
	Present Modes	Standard	Standard	
		Multimedia		
		Game		
		Warm		
		Cool		
Reset Color Settings				
Display Settings	Horizontal Position		50	Yes
	Vertical Position		50	Yes
	Sharpness		50	Yes
	Pixel Clock		50	Yes
	Phase		50	Yes
	Reset Display Settings			Yes
Other Settings	Language	English		Yes
		Espanol		
		Francais		
		Deutsch		
		Portugues(Brasil)		
		简体中文		
		日本語		
	Menu Transparency		20	
	Menu Timer		20	
	Menu Lock	Unlock		
		Lock		
	DDC/CI	Enable		
		Disable		
LCD Conditioning	Enable			
	Disable			
Factory Reset	Reset All Settings			

In OSD dialog box, should show current input video signal current model resolution @ Ver. Freq., optimum resolution.

OSD Message

After disconnecting the cable, Self Test message should show as below:



After disabling the sync output for VGA, DPMS message should show as below for 3s:

“WARING MESSAGE

Entering Power Save”

Press the “↓” or “↑” key and the DPMS message should show as below:

“WARING MESSAGE

There is no signal coming from you computer

Press any key on the keyboard or mouse to wake it”

Factory Mode Introduction

With signal input, press “Power” button to turn off the monitor. Press “Menu” and “Brightness /Plus” buttons together, and then press “Power” button to turn on the monitor. After power on, press “Brightness /Plus” button to enter Factory mode (Fig.10).

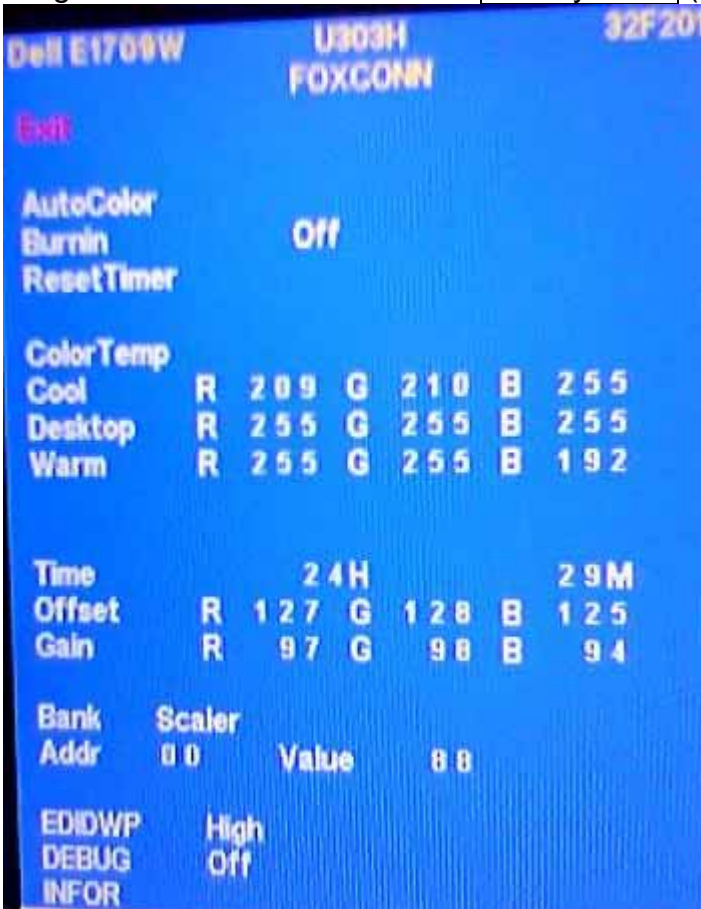

Fig10

Back: Exit from Factory mode and back to NO OSD Status.

Panel: The current-setting panel is highlighted.

Auto Color: Automatically calibrate chip ADC parameters by using internal DAC.

Burn In: Enable or disable the Burn-in mode by choosing ON or OFF.

Reset Timer: Reset the “Turn-on time” of the panel to 0H0M.

Color Temp: The R, G, B of Blue Preset (9300K), Red Preset (5700K) and Normal Preset (6500K) are generated from scaling chip’s back-end white-balance program.

Time: Turn-on time of the panel.

DEBUG: Debug tool of scale IC U105.

Dell panel P/N

LCD supplier	Panel	Supplier P/N	Dell P/N
HSD	17"W	170MGW1	U303H
LPL	17"W	LM171WX3	J666G

Burn-in pattern

Burn-in pattern will self-generate automatically without VGA cable plugged in when the monitor set at Burn-in on mode and burn-in pattern will not be stopped until plugging in the VGA cable. Exit Burn-in mode method as follow: plugging in the VGA cable, press "Menu" button to call out OSD Main Menu, Press "Plus Key" to select "Other Settings Menu" then pop submenu and choose Factory reset.

Auto Color Balance (Automatically calibrate chip ADC parameter by using chip internal DAC.)

- 5.1 If it is a new-built set, press "Auto/Plus" button to execute "Auto Color" at standard video pattern 5-MOSAIC pattern
- 5.2 Please confirm the following steps to perform "Auto Color Balance":
 - Connect the VGA cable with the standard video pattern generator and display 5-MOSAIC pattern on the monitor.
 - Press "Power" button to power off the monitor.
 - Press "Menu" and "Auto/Plus" buttons simultaneously; then press "Power" button to power on the monitor.
 - Press "Plus Key", select "Other Settings Menu", then Press "Plus Key" and choose factory at bottom
 - Set BurnIn Mode item to ON, then execute Auto Color item.
 - After the "Auto Color Balance" process finished, go back to "Other Settings Menu", and press "Factory Reset" to exit Factory mode

Upgrade Firmware to Serial via Flash Cable by ISP_Tool V4.100.exe

7.1 Connect the monitor and PC follow Fig 11



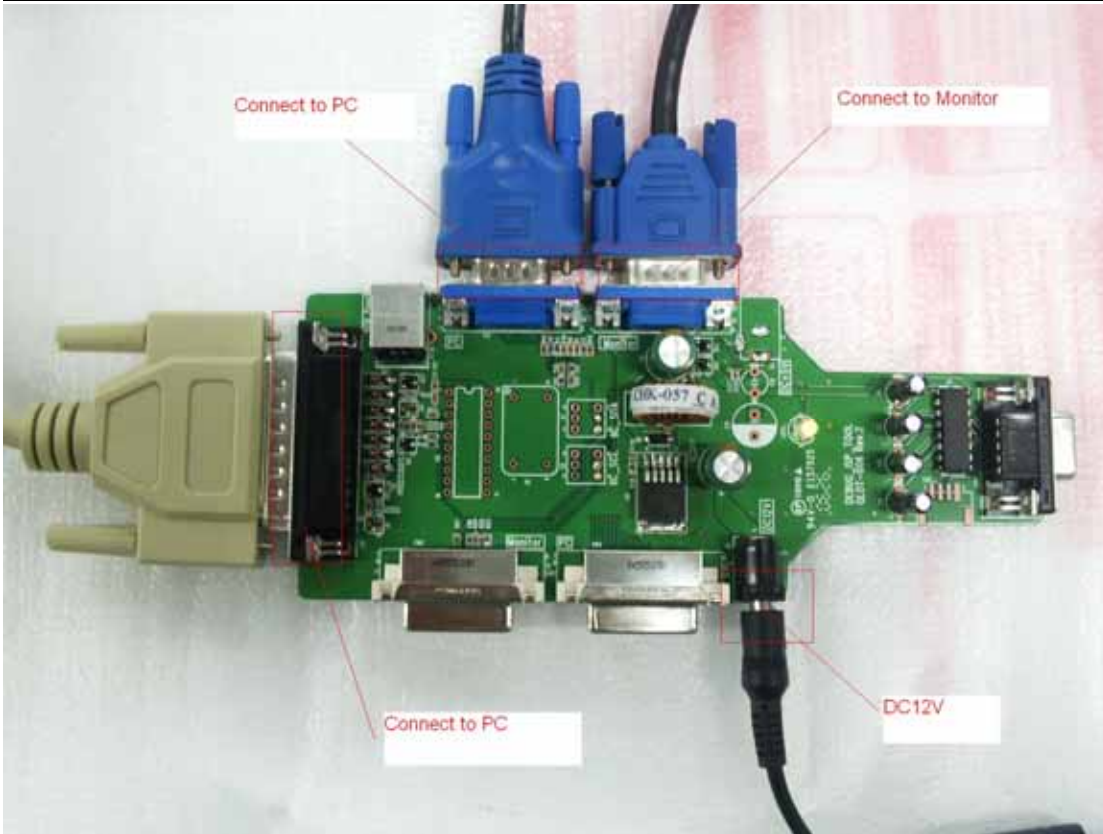

Fig 11

The detailed reprogramming procedures will be described in ISP User's Guide.



Edid 8.4.rar



Edid.rar



ISP User's Guide_20070312.rar



ISP_Tool V4.100.rar

After repair, to ensure the quality you should do the following test and adjustment.

Item	Content	Equipment												
Test OSD function	1.Signal is set as 1440×900@60Hz under General-1 2. LCM button are from left to right, checking whether each single function key and compound function key can be worked.	Chroma Signal Generator												
Contrast Check	1. Set input mode to 1440×900@60Hz 2. Set to 32gray scale pattern 3. Set contrast to the maximum. At most 6 bars cannot be distinguished.	Chroma Signal Generator												
Color Temperature	1. Do “Auto color Balance” at 1440×900@60Hz, 32gray scale pattern 2. Measure color temperature, check if it complies with the following temperature : Warm $x=0.328 \pm 0.03, y=0.344 \pm 0.03$ Desktop $x= 0.313 \pm 0.03, y=0.329 \pm 0.03$ Cool $x= 0.283 \pm 0.03, y=0.298 \pm 0.03$	Chroma Signal Generator and color analyzer												
Modes switching check	1. Use Chroma Pattern Generator to make sequence. VESA (640x480 800x600 1024x768 1152x864 1280x1024 1440×900@60Hz), the detail supported modes (see table 1) and power saving signal. 2. Confirm the above timing modes must be full screen and the picture must be normal. 3. LED is amber at power saving mode.	Chroma Signal Generator												
VGA cable detector	When select VGA model and VGA cable is not plugged out, self-test OSD will be floated.	Visual check												
Y measurement at default setting	1. Set brightness and contrast to default value 75 at 6500K 2. With full white pattern, Y shall be $200 \pm 20 \text{ cd/m}^2$	Chroma Signal Generator and Color Analyzer												
OSD Lock Test 	Soft Lock: When OSD is locked, this icon should appear for only 2 seconds with all buttons pressed, except for the “Menu” and “Power” ones. Hard Lock: Press “Menu” button for 15 seconds enables the “locked” icon to be displayed, which will lock All buttons expect for the “Power”. Press “Menu” button for another 15 seconds enables the “unlock” icon to be shown.	Visual Inspection												
Panel Flicker check	1. Mode:1440×900@60Hz 2. Set Brightness& Contrast to default value (75%) 3. Do “Auto Adjustment” 4. Shut down PC to check whether there’s flicker on the center of the picture.	Equipment:: Chroma Signal Generator & PC												
Power saving	1.Mode:1440×900@60Hz 2.Pattern: full Black 3.Brightness: Max. 4.Contrast: Default 5.Check power consumption at each modes	Chroma signal generator and Power meter AC input:230V/50Hz												
	<table border="1" data-bbox="368 1899 1174 2094"> <thead> <tr> <th>State</th> <th>Power Consumption</th> <th>LED color</th> </tr> </thead> <tbody> <tr> <td>Normal</td> <td><25W</td> <td>Blue</td> </tr> <tr> <td>Stand By</td> <td>< 2W</td> <td>Amber</td> </tr> <tr> <td>Power Key Off</td> <td>< 1W</td> <td>No display</td> </tr> </tbody> </table>		State	Power Consumption	LED color	Normal	<25W	Blue	Stand By	< 2W	Amber	Power Key Off	< 1W	No display
	State		Power Consumption	LED color										
	Normal		<25W	Blue										
	Stand By		< 2W	Amber										
Power Key Off	< 1W	No display												

Chapter 6- TROUBLE SHOOTING

Common Acknowledge

- If you change the M/B, be sure that the U103 and U108 these three components also changed to the new M/B because there was program inside. If not, please re-write EDID or upload firmware into serial flash (U108) via VGA Cable. How to do please refer to the Page 19.
- If you adjust clock and phase, please do it at condition of Windows shut down pattern.
- Please confirm the R/G/B color under 32gray scale pattern.
- This LCM is analog interface. So if the entire screen is an abnormal color that means the problem happen in the analog circuit part, if only some scale appears abnormal color that stand the problem happen in the digital circuit part.
- If you check the H/V position, please use the crosshatch pattern.
- This LCM support 10 timing modes, if the input timing mode is out of specification, "Cannot Display this Video Mode" will be displayed on the screen.
- If brightness uneven, repairs Inverter circuit or change a new panel.
- If you find the vertical line or horizontal line lost on the screen, please change panel.
- If the self-test pattern is moving on the screen, please check whether VGA Cable is plugged in the Monitor or PC
- No Power and LED Off

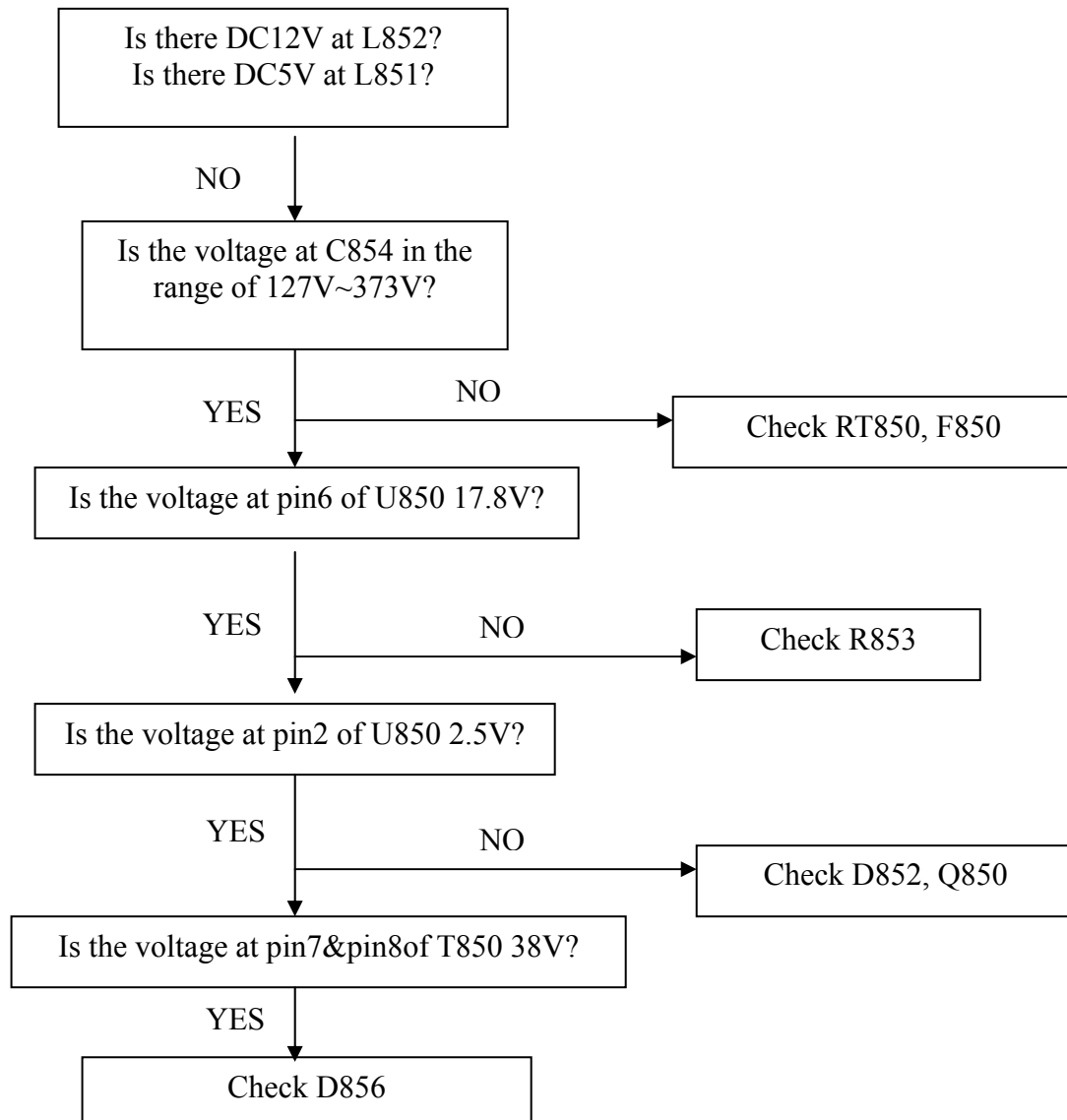

Power (include IF +5V and +3.3V) supply normal but LED off and no display

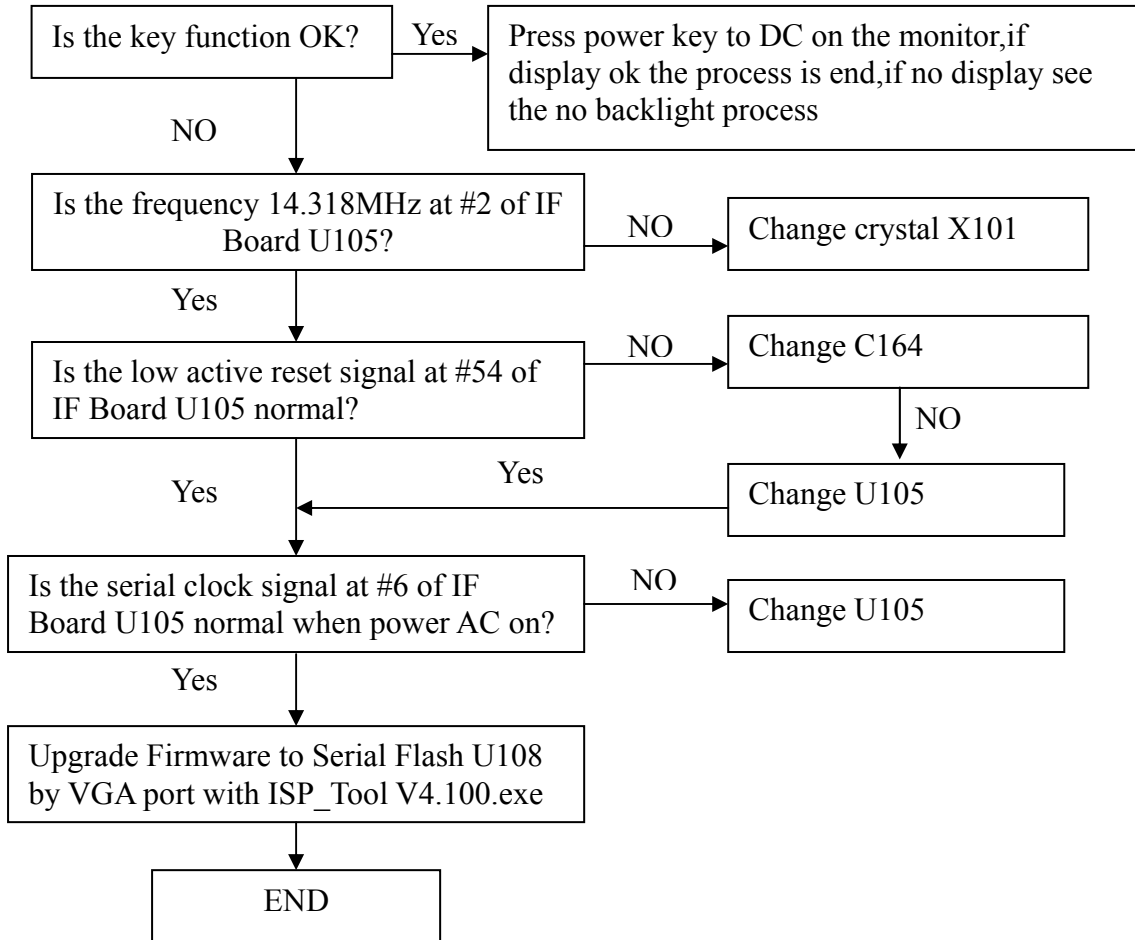

Power (include IF +5V and +3.3V) supply and display normal only LED off

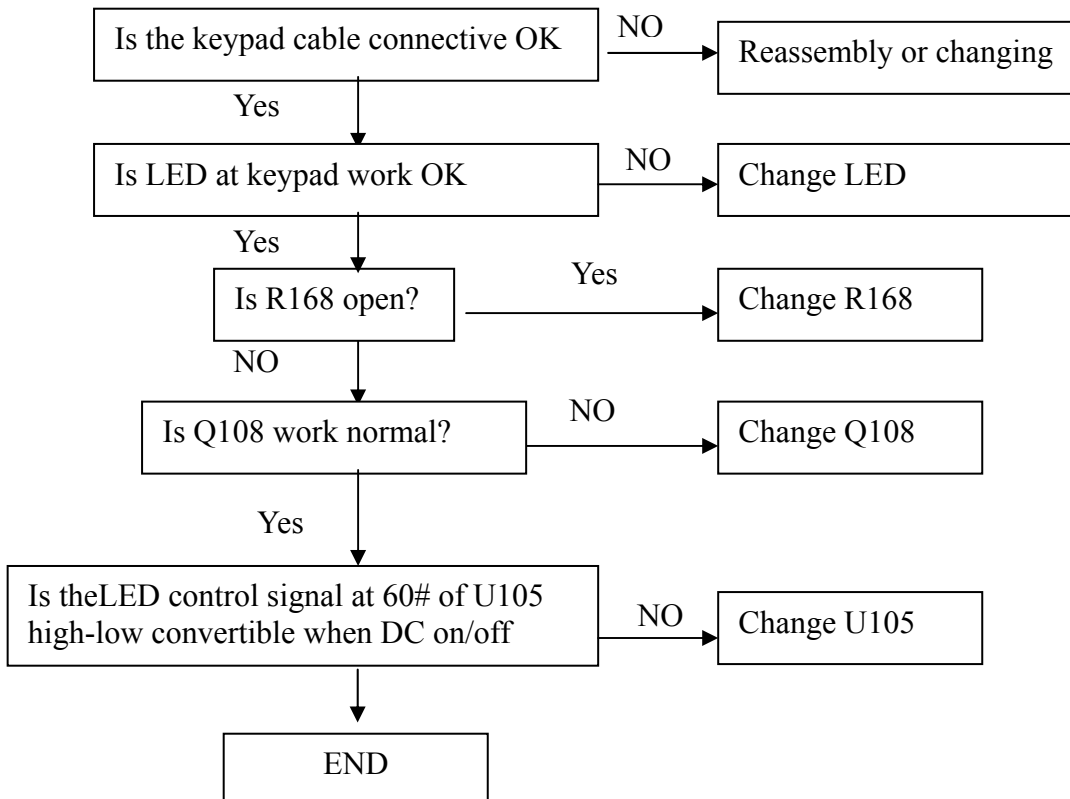

Power (include IF +5V and +3.3V) supply and display normal but LED Amber

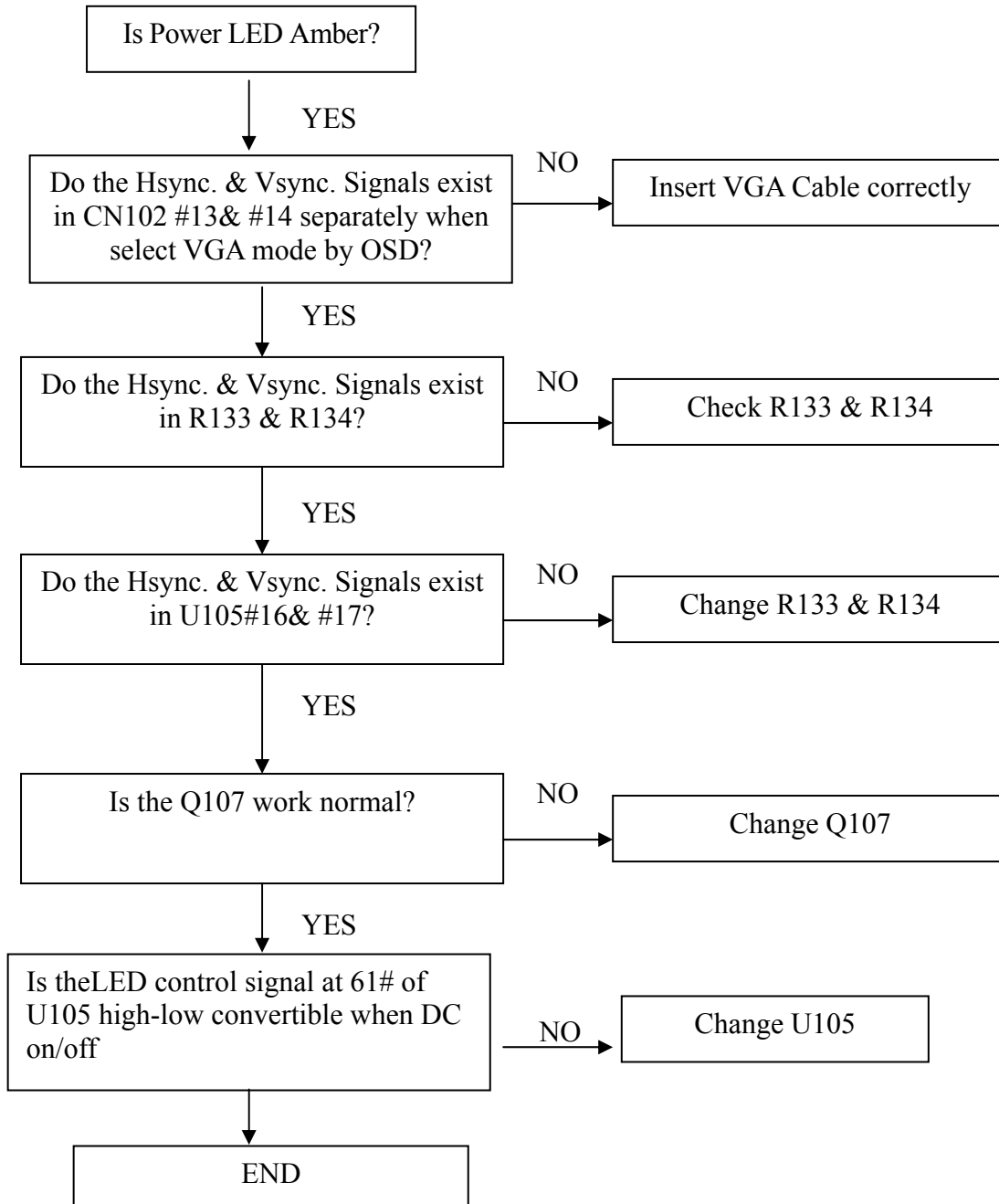

Power (include IF +5V and +3.3V) supply normal, key function OK, but backlight can't be turned on

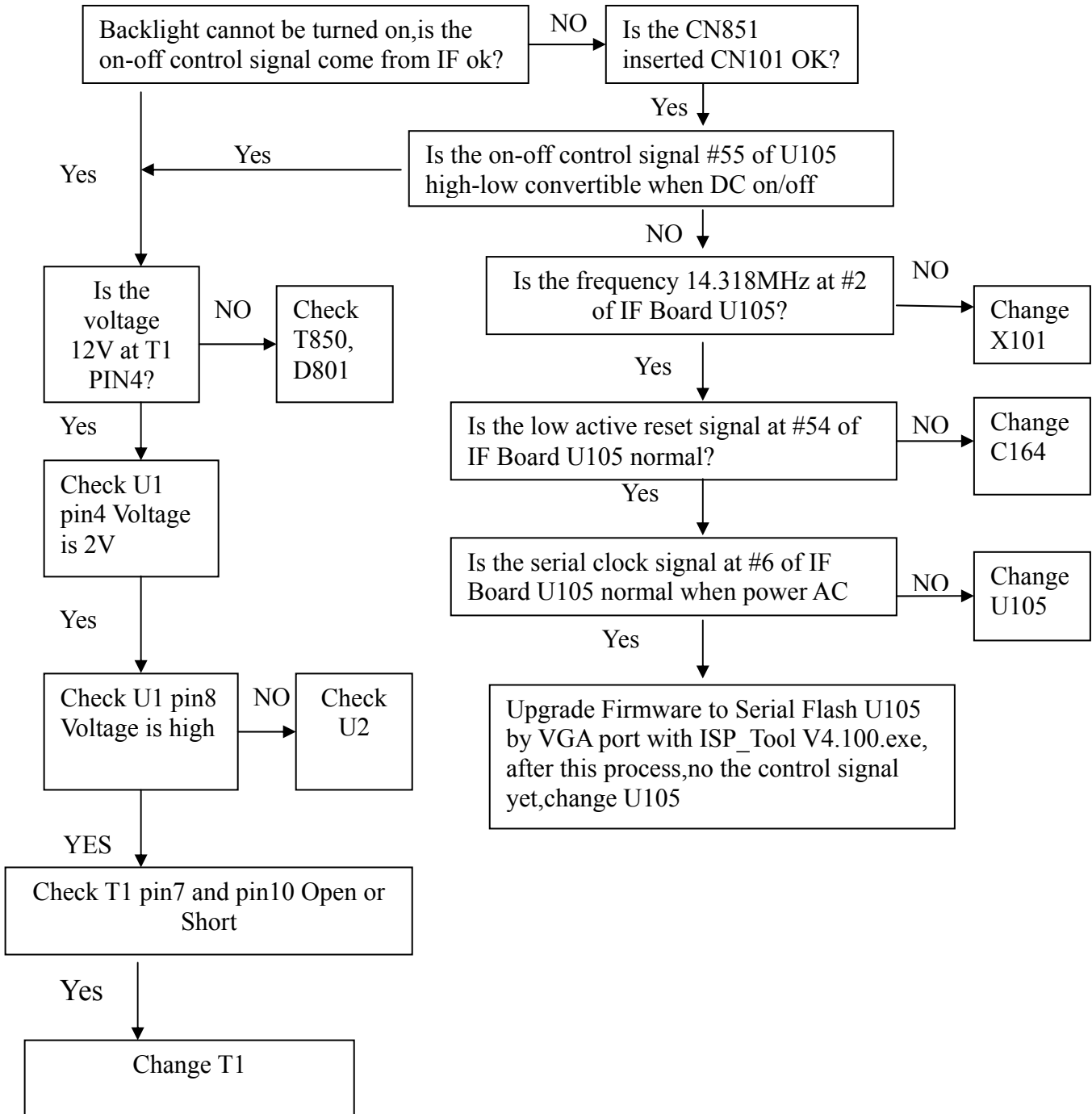

Backlight on, key function and LED accurate indication ok but no picture

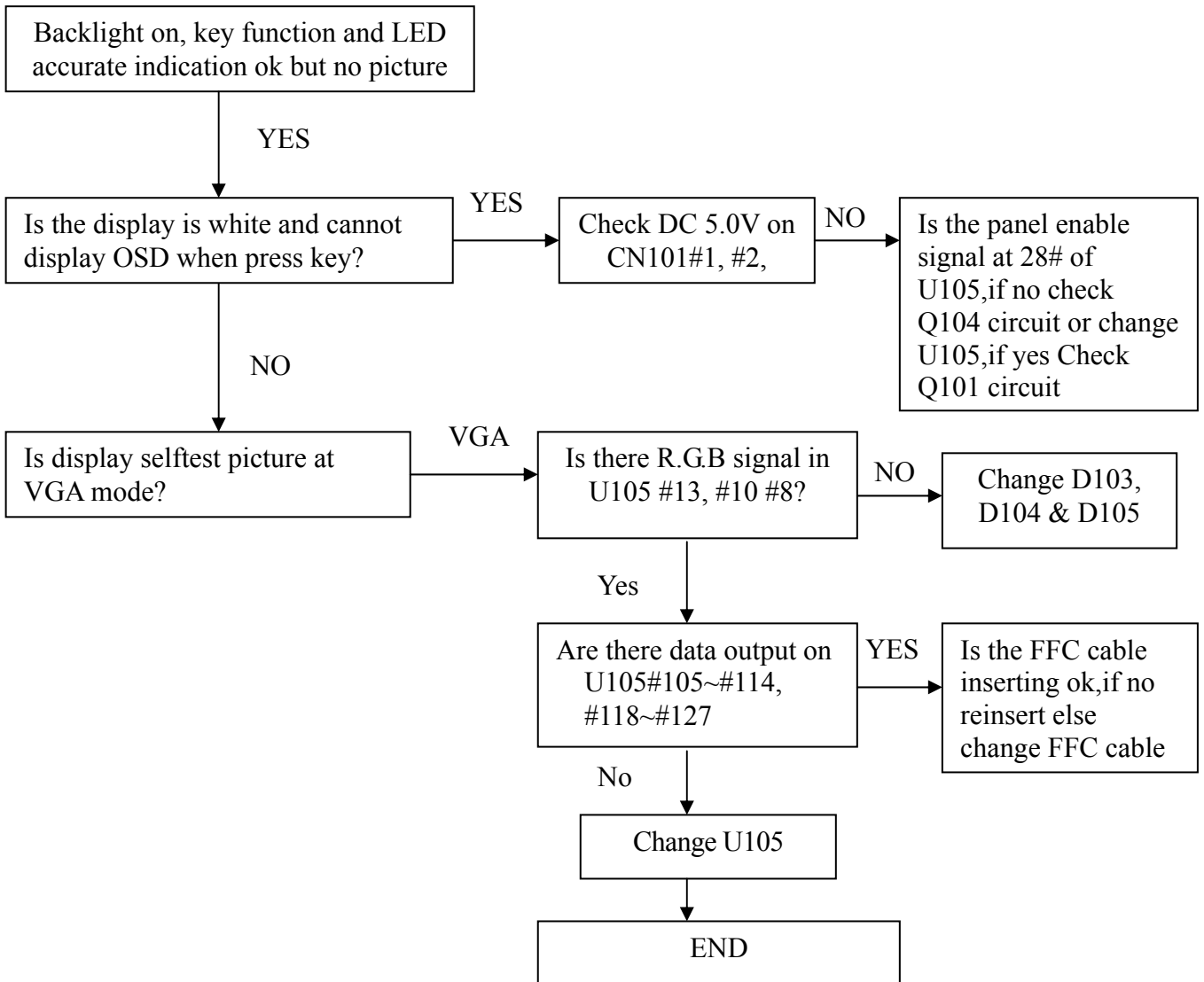

At 32-gray scale pattern, color lost in some scale

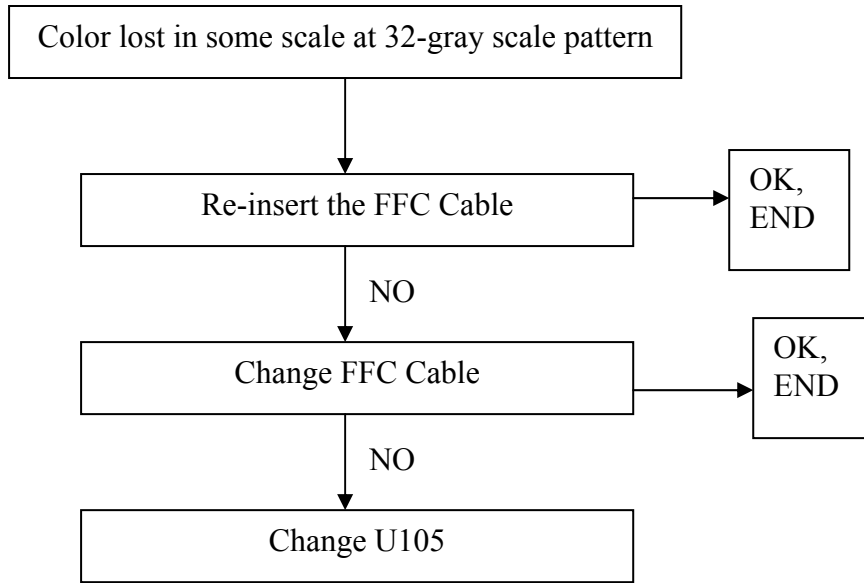

Chapter 7- RECOMMENDED PART LIST

	Item No.	Description	Q'ty	Vendor	Location Remark
1	412000453820R	IC LD7575PS SOP8(LEADTREND) RoHS	1	LEADTREND	U850
2	412000636630R	IC INL837GN SOP16(O2 MICRO) ROHS	1	O2	U1
3	410500070290R	XSTR AP9971GM,N-CH,SO8(APEC) RoHS	1	APEC,	U2
	410050071380R	XSTR AM9945N-T1-PF N-CH,SO8(AP)RoHS	0	AP,	
	410500060271R	XSTR AO4826 DUAL N-CH SOIC8(AOS)RoHS	0	AOS,	
4	426000090540R	XFMR SW 955MH,SPW-054,ROHS	1	FOXCONN	T1
			0	DARFON	
			0	FRONTIE	
			0	LI SHIN	
			0	HUALON	
5	426000091190R	XFMR SW DIP ER28 TP4 920uH SPW-119 ROHS	1	FRONTIER,	T850
			0	FOXCONN	
			0	LI SHIN	
			0	MEIKAI	
6	420436804580R	CAP SEK 68uF/450V M,105°C CF 18x35 RoHS	1	SAMXON	C854
			0	SU'SCON	
			0	ELITE	
7	412000480990R	IC CAT24C02WI-TE13 SOIC-8(CATALYST)RoHS	1	CATALYST	U103
	412000480280R	IC M24C02-WMN6TP SO8 2K (ST)	0	ST	
	412000435481R	IC AT24C02BN-SH-T 2K SOIC8(ATMEL)RoHS	0	ATMEL	
8	412000279480R	IC AT24C04N-10SU-2.7 SOP8 4K(A TMEL)RoHS	1	ATMEL	U106
	412000279280R	IC M24C04-WMN6TP4K SOP8 (ST) RoHS	0	ST	
	412000479990R	IC CAT24C04WI-TE13 SOIC-8(CATALYST)RoHS	0	CATALYST	
10	412000372020R	IC LD1117AL-3.3V-A SOT-223(UTC RoHS	1	UTC,	U101
	412000372830R	IC AS1117L-3.3TR-LF,SOT223(A1S EMI)RoHS	0	A1SEMI,	
	412000372070R	IC AZ1117H-3.3 SOT-223(AAC)RoHS	0	BCD,	
	412000598990H	IC EC50117KBG 3.3V SOT223(E-CMOS)	0	E-CMOS,	
11	412000330130R	IC AP1117E18LA 1.8V (ANACHIP)	1	ANACHIP	U102
	412000330020R	IC LD1117AL-1.8V-A SOT223(UTC)	0	UTC	
	412000599990H	IC EC50117BBG 1.8V SOT223(E-CMOS)	0	E-CMOS,	
	412000330550R	IC AME1117ECGTZ 1.8V,SOT223(AME)	0	AME	
12	412000661620R	IC MX25L2025MC-12G (MXIC)RoH	1	MXIC,	U108
	412000494310R	IC PM25LV020-100SCE SOIC8(PMC)RoHS	0	PMC	
13	412000693060R	IC TSUM1PER-LF-2 PQFP64(MSTAR)	1	MSTAR	U105
14	444099030040R	CON, SMD 1.0MM 30PIN with lock RoHS	1	CVILUX	CN103
			0	P-TWO	
16	491921500000R	PCB,K/P ,2/ENIG/FR4 /08,LE17M6ROHS	1	EXPRESS	
			0	TOPFAITH	
17	491921300100R	PCB,/F BOARD,E1709W ROHS	1	EXPRESS	
			0	TOPFAITH	
18	491911400100R	PCB, P/I ,1/OSP /CEM1/16,LE17M6 RoHS	1	HUIHO	
			0	TATCHUN	

ATTACHMENT 1- Bill of Material

1. Interface board BOM

20080710

ITEM	P/N	Description	Supplier	Usage	Un	Location
	792211300400R	PCBA,I/F BOARD,W/O SPK,LE17M6-410 ROHS				
10	629030022800R	PROGRAM,W/O SPK,LE17M6-410 ROHS		1	PC	
20	792211320400R	PCBA,I/F BOARD,W/O SPK,MI,LE17M6-410 ROH		1	PC	
30	792211340400R	PCBA,I/F BOARD,W/O SPK,SMT,LE17M6-410 RO		1	PC	
40	511130001200R	SOLDER BAR,Sn96.5/Ag3.0/Cu0.5/Ni0.06/Ge0	TOMAS,	0.56	G	

20080710

ITEM	P/N	Description	Supplier	Usage	Un	Location
	792211320400R	PCBA,I/F BOARD,W/O SPK,MI,LE17M6-410 ROH				
10	420421010420R	CAP SD 100uF 16V M,105 S,5x11,RoHS	SAMXON,SU'SCON,	2	PC	C102,C109,
20	420432200420R	CAP EC 22UF 16V M,105 S, 5X11,ROHS	SAMXON,SU'SCON,	3	PC	C103,C136,C138,
30	430631080210R	WFR 8P 2.0MM 90° W/LOCK ROHS	CVILUX,FOXCONN,	1	PC	CN101,
40	430631080220R	WFR 2X4P 2.0MM 90° W/LOCK ROHS	CVILUX,FOXCONN,	1	PC	CN104,
50	432008010270R	XTAL 14.31818MHZ HC-49US DIP 16pF 30PPM	HARMONY,HUAN MOUN,TXC,	1	PC	X101,
60	440819015030R	CON D-SUB FEM.15P RA W/O SCREW DZ11AA1-H	DLK,FOXCONN,ZJGHI,	1	PC	CN102,

20080710

ITEM	P/N	Description	Supplier	Usage	Un	Location
	792211340400R	PCBA,I/F BOARD,W/O SPK,SMT,LE17M6-410 RO				
10	410500068290R	XSTR AP2305GN P-CH SOT23(APEC) RoHS	APEC,	1	PC	Q101,
10	410060018380R	XSTR AM2321P-T1-PF P-CH SOT23(ANALOG POW	AP,	0	PC	
10	410500075270R	XSTR AO3415 P-CH,SOT23(AOS) RoHS	AOS,	0	PC	
20	410500045210R	XSTR PMBT3904 NPN 200MA,40V SOT23(PHILIP	PHILIPS,	2	PC	Q103,Q104,
20	410500045140R	XSTR MMBT3904LT1G NPN 200MA 40V SOT23(ON	ON SEMI,	0	PC	
20	410500045090R	XSTR MMBT3904 NPN SOT-23(PANJIT)RoHS	PANJIT,	0	PC	
20	410500045130R	XSTR MMBT3904 NPN SOT-23(INFIN EON)RoHS	INFINEON,	0	PC	
30	410500046210R	XSTR PMBT3906 PNP 200MA,40V SOT23(PHILIP	PHILIPS,	2	PC	Q107,Q108,
30	410500046180R	XSTR MMBT3906LT1G PNP 200mA 40V SOT23(ON	ON SEMI,	0	PC	
30	410500046090R	XSTR MMBT3906 PNP SOT-23(PANJIT)RoHS	PANJIT,	0	PC	
30	410500046130R	XSTR MMBT3906 PNP SOT-23(INFIN EON)RoHS	INFINEON,	0	PC	
40	411020026210R	DIO BAV99 350mW 70V SOT-23(PHI RoHS	PHILIPS,	4	PC	D102,D103,D104,D105,
40	411020026090R	DIO BAV99 350mW 75V SOT-23(PEC RoHS	PANJIT,	0	PC	
40	411020026020R	DIO BAV99-LF 350mW 70V SOT-23 (FEC)RoHS	FRONTIER,	0	PC	
40	411020026390R	DIO BAV99,SOT-23(INFINEON)RoHS	INFINEON,	0	PC	
50	411130962950R	ZENER 6.2V MMSZ5234B SOD-123(PANJIT)RoH	PANJIT,	6	PC	ZD103,ZD104,ZD105, ZD106,ZD107,ZD102,
50	411121462950R	ZENER 6.2V BZT52-C6V2 SOD-123(WILLAS)ROH	WILLAS,	0	PC	
50	411131562950R	ZENER 6.2V BZT52C6V2-7-F SOD-123(DIODES)	DIODES,	0	PC	
60	412000372020R	IC LD1117AL-3.3V-A SOT-223(UTC RoHS	UTC,	1	PC	U101,
60	412000372830R	IC AS1117L-3.3TR-LF,SOT223(A1S EMI)RoHS	A1SEMI,	0	PC	
60	412000372070R	IC AZ1117H-3.3 SOT-223(AAC)RoHS	BCD,	0	PC	
60	412000598990H	IC EC50117KBG 3.3V SOT223(E-CMOS)	E-CMOS,	0	PC	

70	412000330020R	IC LD1117AL-1.8V-A SOT223(UTC) RoHS	UTC,	1	PC	U102,
70	412000330130R	IC AP1117E18LA 1.8V (ANACHIP) SOT223-3L	ANACHIP,	0	PC	
70	412000330550R	IC AME1117ECGTZ 1.8V,SOT223(AM E)RoHS	AME,	0	PC	
70	412000599990H	IC EC50117BBG 1.8V SOT223(E-CMOS)	E-CMOS,	0	PC	
90	412000693060R	IC TSUM1PER-LF-2 LQFP64 (MSTAR) RoHS	MSTAR,	1	PC	U105,
100	412000494310R	IC PM25LV020-100SCE SOIC8(PMC)RoHS	PMC,	1	PC	U108,
100	412000661620R	IC MX25LV020-12G (MXIC)RoH	MXIC,	0	PC	
110	414918000050R	RES SMD (0402) 0Ω J,RT,RoHS	TA-I,UNIOHM,WALSIN,YAGEO,	3	PC	R137,R138,R121,
120	414916000050R	RES SMD (0603) 0Ω J,RT RoHS	TA-I,UNIOHM,WALSIN,YAGEO,	3	PC	RB101,RB102,RB103,
130	414918010150R	RES SMD (0402) 100Ω J,RT,RoHS	TA-I,UNIOHM,WALSIN,YAGEO,	4	PC	R132,R131,R157,R158,
140	414918010250R	RES SMD (0402) 1KΩ J,RT,RoHS	TA-I,UNIOHM,WALSIN,YAGEO,	10	PC	R133,R134,R141,R154, R155,R156,R159,R160, R171,R191, R102,R103,R106,R129, R140,R142,R143,R144, R146,R147,R148,R163, R166,R169,R176,R177, R190,R192,
150	414918010350R	RES SMD (0402) 10KΩ J,RT,RoHS	TA-I,UNIOHM,WALSIN,YAGEO,	18	PC	R107,R109,R153,
160	414918010450R	RES SMD (0402)100KΩ J,RT,RoHS	TA-I,UNIOHM,WALSIN,YAGEO,	3	PC	R135,R136,
170	414918022250R	RES SMD (0402) 2.2KΩ J,RT,RoHS	TA-I,UNIOHM,WALSIN,YAGEO,	2	PC	R168,
180	414916033150R	RES SMD (0603) 330Ω J,RT RoHS	TA-I,UNIOHM,WALSIN,YAGEO,	1	PC	R125,
190	414918039150R	RES SMD (0402) 390Ω J,RT,RoHS	TA-I,UNIOHM,WALSIN,YAGEO,	1	PC	R114,R115,R116,
200	414918470910R	RES SMD (0402) 47Ω F,RT,RoHS	TA-I,UNIOHM,WALSIN,YAGEO,	3	PC	R172,
210	414918047150R	RES SMD (0402) 470Ω J,RT,RoHS	TA-I,UNIOHM,WALSIN,YAGEO,	1	PC	R105,R110,R127,R128, R161,R162,
220	414918047250R	RES SMD (0402) 4.7KΩ J,RT,RoHS	TA-I,UNIOHM,WALSIN,YAGEO,	6	PC	R108,
230	414918047350R	RES SMD (0402) 47KΩ J,RT,RoHS	TA-I,UNIOHM,WALSIN,YAGEO,	1	PC	R117,R118,R119,
240	414918750910R	RES SMD (0402) 75Ω F,RT,RoHS	TA-I,UNIOHM,WALSIN,YAGEO,	3	PC	R122,R123,R124,
250	414918845910R	RES SMD (0402) 84.5Ω F,RT,RoHS	TA-I,UNIOHM,WALSIN,YAGEO,	3	PC	R165,
260	414916056150R	RES SMD (0603) 560Ω J,RT RoHS REV:A	TA-I,UNIOHM,WALSIN,YAGEO,	1	PC	C104,C105,C106,C108, C110,C111,C113,C114, C115,C119,C120,C121, C122,C123,C124,C125, C126,C128,C134,C135, C137,C139,C165,C167, C169,C170,C171,C172, C173,C174,
270	419351044010R	C SMD(0402) X5R 0.1uF/16V K,RoHS	DARFON,TDK,WALSIN,YAGEO,	30	PC	C112,C140,C164,
280	419311054070R	C SMD(0805) X7R 1uF/16V K RoHS REV:A	DARFON,MURATA,TDK, WALSIN,YAGEO,	3	PC	C158,C157,
290	419301000510R	C SMD(0402) NPO 10PF/50V J,RoHS	DARFON,MURATA,TDK, WALSIN,YAGEO,	2	PC	C130,C129,
300	419302200510R	C SMD(0402) NPO 22PF/50V J,RoHS	DARFON,MURATA,TDK, WALSIN,YAGEO,	2	PC	C143,
310	419314734010R	C SMD(0402) X7R 0.047uF/16V K,RoHS	DARFON,TDK,WALSIN,YAGEO,	1	PC	EP101,EP102,
320	432002500020R	ESD SMD(0603) 5P/35V(INPAQ) OSC-03-09-03	INPAQ,	2	PC	
320	432009500080R	VARIST ESD SMD(0603) 5P/62V(LTR) LVSL161	LTR,	0	PC	
330	432002312144R	BEAD CORE SMD(0603)120Ω 300mA SBK160808	CHILISIN,TAI-TECH,	1	PC	FB101,
340	432002360140R	BEAD CORE SMD(0603)60Ω 600mA, GBK160808	CHILISIN,TAI-TECH,	3	PC	FB104,FB103,FB102,
350	444099030040R	CON, SMD 1.0MM 30PIN with lock RoHS	CVILUX,P-TWO,	1	PC	CN103,
360	411090005451R	SCHTKY SSM24APT 40V/2A SMA-S(CHENMKO)RoH	CHENMKO,	1	PC	D101,
360	411090005311R	SCHTKY B240A 40V/2A SMA(DIODES RoHS	DIODES,	0	PC	
360	411090005460R	SCHTKY SM240A-LF 40V/2A DO-214AC(SECOS)	SECOS,	0	PC	
370	412000435481R	IC AT24C02BN-SH-T 2K SOIC8(ATMEL)RoHS	ATMEL,	1	PC	U103,
370	412000480280R	IC M24C02-RMN6TP SO8(ST)RoHS	ST,	0	PC	
370	412000480990R	IC CAT24C02WI-TE13 SOIC-8(CATALYST)RoHS	CATALYST,	0	PC	

380	411020047210R	DIO BAV70 85V SOT23 (PHILIPS) RoHS	PHILIPS,	1	PC	D106,
380	411020047020R	DIO BAV70-LF, 70V SOT-23(FEC) ROHS	FRONTIER,	0	PC	
380	411020047090R	DIO BAV70, 70V SOT-23(PEC) ROHS	PANJIT,	0	PC	
390	419311020010R	C SMD(0402) X7R 1000PF/50V K,RoHS	DARFON,WALSIN,YAGEO,	1	PC	C175,
400	412000279480R	IC AT24C04N-10SU-2.7 SOP8 4K(A TMEL)RoHS	ATMEL,	1	PC	U106,
400	412000279280R	IC M24C04-WMN6TP4K SOP8 (ST) RoHS	ST,	0	PC	
400	412000479990R	IC CAT24C04WI-TE13 SOIC-8(CATALYST)RoHS	CATALYST,	0	PC	
410	491921300100R	PCB,I/F, 2/OSP /FR4 /16,LE17M6 ROHS	EXPRESS, TOP FAITH,	1	PC	

2. Power board BOM

ITEM	P/N	Revision	Description	Supplier	Usage	Location
	792211400400R	AA	PCBA,P/I BOARD,W/O SPK,LE17M6-410 ROHS			
10	792211410400R	AA	PCBA,P/I BOARD,W/O SPK,AI,LE17M6-410 ROH			1
20	792211420400R	AA	PCBA,P/I BOARD,W/O SPK,MI,LE17M6-410 ROH			1
30	791112100000R	AA	PCBA,CONTROL/B(PWR LD7575),LE1996 RoHS			1
40	792212100000R	AA	PCBA,CONTROL/B(PWR DIODE),LE17M6 RoHS			1
50	792212200000R	AA	PCBA,CONTROL/B(INV.),LE17M6 RoHS			1
60	735110009900R	A	ASSY,H/S,Q850, LE17M6,ROHS			1
70	511130001200R	A	SOLDER BAR,Sn96.5/Ag3.0/Cu0.5/Ni0.06/Ge0	TOMAS,		8.6
80	511110000103R	A	HOT-MELT ADHESIVES,UB-618	U-BOND,		2
80	511110000101R	A	HOT-MELT ADHESIVES (#526)	EXCELSTAR,		0
90	511110000501R	A	SILICONE RTV RUBBER,UB-511(EURO)	EURO,		0.45

ITEM	P/N	Revision	Description	Supplier	Usage	Location
	735110009900R	A	ASSY,H/S,Q850, LE17M6,ROHS			
10	410500059290R	A	XSTR AP2761I-A N-CH TO-220CFM ADVANCED P	APEC,		1 Q850,
10	410050103050R	A	XSTR FMA09N65GX N-CH TO-220F(FUJI) RoHS	FUJI,		0
10	410050057280R	A	XSTR STP8NK80ZFP N-CH TO220FP (ST)	ST,		0
40	507300003400R	A	HEATSINK,"-", LE1513	DMC,K-ENERGY, ORIENTAL POWER, TOP RICH,		1
50	509146306200R	A	SCREW,P,CROSS,W/WAS,M3*6,Zn-Cc	GAOYI,LIQUAN,YIJIE,		1

ITEM	P/N	Revision	Description	Supplier	Usage	Location
	791112100000R	AA	PCBA,CONTROL/B(PWR LD7575),LE1996 RoHS			
10	430632080020R	A	WFR. 8P 2.54mm 90°,HEADER,W/O PIN2,RoHS	CIVILUX,FOXCONN,JOWLE,		1 CN852,
20	791112140000R	AA	PCBA,CONTROL/B(PWR LD7575),SMD,LE1996 RO			1
30	511130001200R	A	SOLDER BAR,Sn96.5/Ag3.0/Cu0.5/Ni0.06/Ge0	TOMAS,		0.5

ITEM	P/N	Revision	Description	Supplier	Usage	Location
	792211410400R	AA	PCBA,P/I BOARD,W/O SPK,AI,LE17M6-410 ROH			
10	792211450400R	AA	PCBA,P/I BOARD,W/O SPK,AI/A,LE17M6-410 R			1
20	792211460400R	AA	PCBA,P/I BOARD,W/O SPK,AI/R,LE17M6-410 R			1

ITEM	P/N	Revision	Description	Supplier	Usage	Location
	792211420400R	AA	PCBA,P/I BOARD,W/O SPK,MI,LE17M6-410 ROH			

10	430631020090R A	WFR 2 CIRCUIT/2P(8MM) R/A W/L ROHS	FCN,CVILUX,	2	CN1,CN2,
20	440149000400R A	SKT AC 10A/250V U/C/V,CDJ-3(E4)-BT3.6-0	DLK,TECX,	1	CN850,
30	430300802030R A	HRN ASS'Y 8P 100mm UL1007#26AWG LOCK	FOXCONN,JVE,RISE,	1	CN851,
40	418115051520R A	CAP CD NPO 15pF 3KV J,S7.5 RoHS	JNC,SUCCESS(SEC),	1	C15,
50	416203323620R A	CAP MEY 3300pF 250V M Y2 Y5V P=10mm,W/O	JNC,POE,SUCCESS(SEC),	2	C850,C851,
60	416194743011R A	CAP MEX 0.47uF 275V K X2,F15 RoHS	ARCOTRONIC, EUROPTRONIC,HJC,SCC,	1	C852,
70	420436804580R A	CAP SEK 68uF/450V M,105°C CF 18x35 RoHS	ELITE,SAMXON,SU'SCON,	1	C854,
80	416213323620R A	CAP MEY 3300pF 250V M Y1,F10mm W/O FORMI	JNC,POE,SUCCESS(SEC),	1	C860,
90	416304723510R A	CAP PP 0.0047uF 250V J,F7.5 RoHS	EUROPTRONIC,HJC,SCC,	1	C875,
100	415350823550R A	RES MOF 2W 82KΩ J,MINI,HK15 RoHS	FUTABA,TZAI YUAN,	1	R854,
110	415502758551R A	RES NKNP 2W 0.75Ω J, MINI,HK15,ROHS	FUTABA,TZAI YUAN,	1	R859,
120	415350100550R A	RES MOF 2W 10Ω J,MINI,HK15, RoHS	FUTABA,TZAI YUAN,	1	R863,
130	432009400701R A	NTC 5Ω 4A 10φ P=5mm, F RoHS	THINKING,UPPERMOST,	1	RT850,
140	426000050070R A	CHOKE L-FILTER 12mH LIN-007 ET-20,RoHS	DARFON,FOXCONN, LISHIN,MEIKAI,	1	L850,
150	425000010530R A	COIL CHK 5uH 7.8X10 CHK-053 0 181085R0L	CHILISIN,DARFON, FOXCONN,FRONTIER,TAICHANG,	2	L851,L852,
160	411050012010R A	DIO BRDG GBU405 600V/4A(TSC)RoHS	TSC,	1	D850,
160	411050012020R A	DIO BRDG GBU4-06-BF52 600V/4A(FEC)RoHS	FRONTIER,	0	
170	411090050090R A	SCHTKY SB5150F98 150V/5A DO-201AD (PANJI	PANJIT,	1	D856,
170	411090050020R A	SCHTKY SR515F69-LF 150V/5A DO-201AD (FEC	FRONTIER,	0	
170	411090050450R A	SCHTKY SR5150PT-F 150V/5A DO-201AD (CHEN	CHENMKO,	0	
180	426000090540R A	XFMR SW 955mH,SPW-054,RoHS	DARFON,FOXCONN, FRONTIER,LISHIN,	1	T1,
190	426000091190R A	XFMR SW DIP ER28 TP4 920uH SPW-119 ROHS	FOXCONN,FRONTIER, LISHIN,MEIKAI,	1	T850,
200	412140002380R A	IC LTV817M-PR VDE (LITE-ON) P=10mm RoHS	LITEON,	1	I850,
210	418103051920R A	CAP CD NPO 3pF 3KV D,S7.5, RoHS	JNC,SUCCESS(SEC),	2	C17,C19,

ITEM	P/N	Revision	Description	Supplier	Usage	Location
	792212100000R AA		PCBA,CONTROL/B(PWR DIODE),LE17M6 RoHS			
10	430632080020R A		WFR. 8P 2.54mm 90°,HEADER,W/O PIN2,RoHS	CVILUX,FOXCONN,JOWLE,	1	CN853,
20	792212140000R AA		PCBA,CONTROL/B(PWR DIODE),SMT,LE17M6 Ro		1	
30	511130001200R A		SOLDER BAR,Sn96.5/Ag3.0/Cu0.5/Ni0.06/Ge0	TOMAS,	0.5	

ITEM	P/N	Revision	Description	Supplier	Usage	Location
	792212200000R AA		PCBA,CONTROL/B(INV.),LE17M6 RoHS			
10	430632200010R A		WFR. 20P 2.54mm 90°,HEADER,RoHS	CVILUX,FOXCONN,	1	CN5,
20	792212240000R AA		PCBA,CONTROL/B(INV.),SMD,LE17M6 RoHS		1	
30	511130001200R A		SOLDER BAR,Sn96.5/Ag3.0/Cu0.5/Ni0.06/Ge0	TOMAS,	0.5	

ITEM	P/N	Revision	Description	Supplier	Usage	Location
	791112140000R AA		PCBA,CONTROL/B(PWR LD7575),SMD,LE1996 RO			
10	419312210060R A		C SMD(0603) X7R 220PF/50V K RoHS	DARFON,TDK,WALSIN,YAGEO,	1	C846,
20	419311040060R A		C SMD(0603) X7R 0.1uF/50V K RoHS	DARFON,TDK,WALSIN,YAGEO,	1	C848,
30	419311020060R A		C SMD(0603) X7R 1000PF/50V K RoHS	DARFON,TDK,WALSIN,YAGEO,	1	C849,
40	414916010350R A		RES SMD (0603) 10KΩ J,RT RoHS	TA-I,WALSIN,YAGEO,	1	R841,

50	414904020350R	A	RES SMD (1206) 20K Ω J,RT RoHS	TA-I,WALSIN,YAGEO,	2 R843,R842,
60	414916010410R	A	RES SMD (0603) 100K F,RT RoHS	TA-I,WALSIN,YAGEO,	1 R846,
70	414916200910R	A	RES SMD (0603) 20 Ω F,RT,RoHS	TA-I,WALSIN,YAGEO,	1 R848,
80	414916022150R	A	RES SMD (0603) 220 Ω J,RT RoHS REV:A	TA-I,WALSIN,YAGEO,	1 R849,
90	412000453820R	A	IC LD7575PS SOP8(LEADTREND) RoHS	LEADTREND,	1 U850,
110	490712100200R	A	PCB,CONTROL(PWR LD7575),LE1521	GOODWELL,SHENG HUA,WELFARE,	1
120	511130002200R	A	SOLDER PASTE,S _n 96.5-Ag3.0-Cu0.5 ROHS	TOMAS,	0.1
120	511130002201R	A	SOLDER PASTE,S _n 96.5%Ag3.0%Cu0.5%	TOMAS,	0
120	511130002202R	A	SOLDER PASTE,S _n 95.5%Ag3.9%Cu0.6%	TAMURA,	0

ITEM	P/N	Revision	Description	Supplier	Usage Location
	792211450400R	AA	PCBA,P/I BOARD,W/O SPK,AI/A,LE17M6-410 R		
10	411022003020R	A	DIO 1N4148-LF 75V/0.15A AT (FEC)RoHS	FRONTIER,	2 D1,D2,
10	411022003210R	A	DIO 1N4148 75V/0.2A AT (PHIL) RoHS	PHILIPS,	0
10	411020048090R	A	DIO 1N4148-35 75V/0.15A,DO35(P EC)RoHS	PANJIT,	0
20	411032006020R	A	DIO FR10-10-LF 1000V/1A AT(FRO NTIER)RoH	FRONTIER,	1 D851,
20	411032006040R	A	DIO FR107 1000V/1A DO-41(MOSPE C)RoHS	MOSPEC,	0
20	411020053090R	A	DIO PS1010R 1000V/1A DO-41(PAN JIT)RoHS	PANJIT,	0
30	411020064090R	A	DIO ER104 400V/1A DO-41(PANJIT RoHS)	PANJIT,	1 D852,
30	411032001020R	A	DIO SF10-04-LF 400V/1A DO-41(F RONTIER)R	FRONTIER,	0
40	411020080090R	A	DIO P6KE170A 600W/100A DO-15 (PANJIT)	PANJIT,	1 D853,
40	411020080460R	A	DIO P6KE170A 600W/100A DO-15 (SECOS)	SECOS,	0
40	411020080020R	A	DIO P6KE170A-LF 600W/100A DO-15(FEC)	FRONTIER,	0
50	415216040140R	A	RES MF 1/8W 604 Ω F,AT,ROHS	TZAI YUAN,UNIOHM,	1 R19,
60	415110471540R	A	RES CF 1/8W 470 Ω J,AT,RoHS	TZAI YUAN,UNIOHM,	2 R31,R32,
70	415237503140R	A	RES MF 1/2W 750K Ω F AT MINI,ROHS	TZAI YUAN,UNIOHM,	2 R850,R851,
80	414040208540R	A	RES FSM 1W 0.2 Ω J,AT MINI RoHS	FUTABA,TZAI YUAN,	1 R853,
90	415211002140R	A	RES MF 1/8W 10K Ω F,AT RoHS	TZAI YUAN,UNIOHM,	1 R855,
100	415320100540R	A	RES MOF 1/4W 10 Ω J,AT MINI RoHS	FUTABA,TZAI YUAN,	1 R856,
110	415222700140R	A	RES MF 1/4W 270 Ω F,AT,MINI,RoHS	TZAI YUAN,UNIOHM,	1 R857,
120	415215101140R	A	RES MF 1/8W 5.1K Ω F,AT,RoHS	TZAI YUAN,UNIOHM,	1 R858,
130	415213601140R	A	RES MF 1/8W 3.6K Ω F,AT ,ROHS	TZAI YUAN,UNIOHM,	1 R861,
140	415212703140R	A	RES MF 1/8W 270K Ω F,AT,RoHS	TZAI YUAN,UNIOHM,	1 R871,
150	415212002140R	A	RES MF 1/8W 20K Ω F,AT ,ROHS	TZAI YUAN,UNIOHM,	1 R880,
160	430613050100R	A	FUSE SLOW PICO II 5A/125V U/C,AT,ROHS	LITTELFUSE,	1 F851,
160	430613050101R	A	FUSE SLOW 5A/125V U/C,AT,ROHS	WALTER,	0
170	432002200190R	A	FERR BEAD 3.5x9x0.65,VT,RoHS,RH03509ST-B	CHILISIN,TAICHANG,	1 L801,
180	491911400100R	A	PCB, P/I ,1/OSP /CEM1/16,LE17M6 RoHS	HUIHO,TATCHUN,	1
190	430405000000R	A	JMPR ROLL/KG D=0.6mm,AT,RoHS 7.5MM	HOTRON,YUANYE,	100 J3,J4,
190	430405000000R	A	JMPR ROLL/KG D=0.6mm,AT,RoHS 7.5MM	HOTRON,YUANYE,	0
200	430405000000R	A	JMPR ROLL/KG D=0.6mm,AT,RoHS 12.5MM	HOTRON,YUANYE,	50 J1,
200	430405000000R	A	JMPR ROLL/KG D=0.6mm,AT,RoHS 12.5MM	HOTRON,YUANYE,	0
210	430405000000R	A	JMPR ROLL/KG D=0.6mm,AT,RoHS 15MM	HOTRON,YUANYE,	50 J2,
210	430405000000R	A	JMPR ROLL/KG D=0.6mm,AT,RoHS 15MM	HOTRON,YUANYE,	0

220	430405000000R	A	JMPR ROLL/KG D=0.6mm,AT,RoHS 20MM	HOTRON,YUANYE,	50 J5,
220	430405000000R	A	JMPR ROLL/KG D=0.6mm,AT,RoHS 20MM	HOTRON,YUANYE,	0
230	430405000000R	A	JMPR ROLL/KG D=0.6mm,AT,RoHS 10MM	HOTRON,YUANYE,	50 J6,
230	430405000000R	A	JMPR ROLL/KG D=0.6mm,AT,RoHS 10MM	HOTRON,YUANYE,	0
240	506140005700R	A	LABEL,BARCODE,BLANK,33x7mm, ROHS,FOR PCB	HENGMINGDA,JIAYINMEI,KAIDA,	1

ITEM	P/N	Revision	Description	Supplier	Usage Location
	792211460400R	AA	PCBA,P/I BOARD,W/O SPK,AI/R,LE17M6-410 R		
10	420426810261R	A	CAP SD 680UF/25V M 105°C ST 10X20 ROHS	LELON,SAMXON,SU'SCON,	2 C856,C864,
20	420424710260R	A	CAP SD 470uF/25V M 105°C ST 10x16,RoHS	LELON,SAMXON,SU'SCON,	2 C858,C21,
30	418210233030R	A	CAP CD X7R 1000pF/1KV K,VT 2X7R102K102K5	JNC,POE,SUCCESS(SEC),WANSHENG,	3 C861,C863,C871,
40	418310413630R	A	CAP CD Y5V 0.1uF 50V Z,VT RoHS	JNC,POE,SUCCESS(SEC),WANSHENG,	1 C876,
50	420421000530R	A	CAP SD 10uF/50V M,VT 105°C 5x11 RoHS	LELON,SAMXON,SU'SCON,	1 C878,
60	430613830290R	A	FUSE TIME LAG 3.15A/250V,RoHS	BELFUSE,CONQUER,LITTELFUSE,WALTER,	1 F850,

ITEM	P/N	Revision	Description	Supplier	Usage Location
	792212140000R	AA	PCBA,CONTROL/B(PWR DIODE),SMT,LE17M6 Ro		
10	419311030070R	A	C SMD(0805) X7R 0.01uF/50V K RoHS	DARFON,TDK,WALSIN,YAGEO,	1 C801,
20	419311040070R	A	C SMD(0805) X7R 0.1uF/50V K RoHS REV:A	DARFON,TDK,WALSIN,YAGEO,	1 C802,
30	414904010050R	A	RES SMD (1206) 10Ω J,RT RoHS	TA-I,UNIOHM,WALSIN,YAGEO,	1 R801,
40	414908100210R	A	RES SMD (0805) 10KΩ F,RT RoHS REV:A	TA-I,UNIOHM,WALSIN,YAGEO,	1 R803,
50	414908330110R	A	RES SMD (0805) 3.3KΩ F,RT RoHS REV:A	TA-I,UNIOHM,WALSIN,YAGEO,	1 R804,
60	411030075090R	A	DIO ED602CS 200V/6A TO-252(PANJIT)	PANJIT,	1 D801,
70	412022002831R	A	IC AS431HM /TR-LF SOT23-3(A1semi)Rohs	A1SEMI,	1 I851,
70	412000715020R	A	IC TL431K-AE3-R SOT23(UTC)	UTC,	0
80	491912100100R	A	PCB,CRL-P,2/OSP /FR4 /16,LE17M6	EXPRESS,TOP FAITH,	1
90	511130002200R	A	SOLDER PASTE,Sn96.5-Ag3.0-Cu0.5 ROHS	TOMAS,	0.1
90	511130002201R	A	SOLDER PASTE,Sn96.5%Ag3.0%Cu0.5%	TOMAS,	0
90	511130002202R	A	SOLDER PASTE,Sn95.5%Ag3.9%Cu0.6%	TAMURA,	0

ITEM	P/N	Revision	Description	Supplier	Usage Location
	792212240000R	AA	PCBA,CONTROL/B(INV.),SMD,LE17M6 RoHS		
10	419312254070R	A	C SMD(0805) X7R 2.2uF 16V K RoHS	DARFON,MURATA,TAIYO,TDK,WALSIN,YAGEO,	3 C1,C10,C5,
20	419311020060R	A	C SMD(0603) X7R 1000PF/50V K RoHS	DARFON,TDK,WALSIN,YAGEO,	1 C2,
40	419311040070R	A	C SMD(0805) X7R 0.1uF/50V K RoHS REV:A	DARFON,TDK,WALSIN,YAGEO,	1 C24,
50	419311033060R	A	C SMD(0603) X7R 0.01uF/25V K RoHS	DARFON,TDK,WALSIN,YAGEO,	4 C13,C14,C3,C7,
60	419312720060R	A	C SMD(0603) X7R 2700PF/50V K RoHS	DARFON,TDK,WALSIN,YAGEO,	2 C25,C26,
70	419313333060R	A	C SMD(0603) X7R 0.033uF/25V K RoHS	DARFON,TDK,WALSIN,YAGEO,	1 C6,
80	419311020070R	A	C SMD(0805) X7R 1000PF/50V K RoHS	DARFON,TDK,WALSIN,YAGEO,	2 C22,C23,
90	419314733060R	A	C SMD(0603) X7R 0.047uF/25V K RoHS	DARFON,TDK,WALSIN,YAGEO,	1 C8,
100	419302710560R	A	C SMD(0603) NPO 270PF/50V J RoHS REV:A	MURATA,TAIYO,TDK,WALSIN,YAGEO,	1 C9,
110	414916100910R	A	RES SMD (0603) 10Ω F,RT,RoHS	TA-I,UNIOHM,WALSIN,YAGEO,	1 R1,
120	414916330410R	A	RES SMD (0603) 3.3M F RT RoHS	TA-I,UNIOHM,WALSIN,YAGEO,	1 R11,
130	414916910210R	A	RES SMD (0603) 91KΩ F,RT RoHS	TA-I,UNIOHM,WALSIN,YAGEO,	1 R12,

140	414916100410R	A	RES SMD (0603) 1M Ω F,RT RoHS	TA-I,UNIOHM,WALSIN,YAGEO,	2	R14,R13,
150	414916470210R	A	RES SMD (0603) 47K Ω F,RT RoHS	TA-I,UNIOHM,WALSIN,YAGEO,	1	R5,
160	414916100310R	A	RES SMD (0603) 100K Ω F,RT RoHS	TA-I,UNIOHM,WALSIN,YAGEO,	6	R16,R6,R2,R20,R21,R9,
170	414916100210R	A	RES SMD (0603) 10K Ω F,RT RoHS	TA-I,UNIOHM,WALSIN,YAGEO,	3	R3,R4,R15,
180	414916000050R	A	RES SMD (0603) 0 Ω J,RT RoHS	TA-I,UNIOHM,WALSIN,YAGEO,	2	R18,R26,
190	414916470110R	A	RES SMD (0603) 4.7K Ω F,RT RoHS	TA-I,UNIOHM,WALSIN,YAGEO,	1	R24,
210	414916330310R	A	RES SMD (0603) 330K Ω F,RT RoHS	TA-I,UNIOHM,WALSIN,YAGEO,	1	R7,
220	414916082450R	A	RES SMD (0603) 820K Ω J,RT,RoHS	TA-I,UNIOHM,WALSIN,YAGEO,	1	R8,
230	414908033050R	A	RES SMD (0805) 33 Ω J,RT RoHS	TA-I,UNIOHM,WALSIN,YAGEO,	2	R29,R30,
240	412000636630R	A	IC INL837GN SOP16(O2 MICRO) ROHS	O2,	1	U1,
250	410500070290R	A	XSTR AP9971GM,N-CH,SO8(APEC) RoHS	APEC,	1	U2,
250	410500060271R	A	XSTR AO4826 DUAL N-CH SOIC8(AOS)RoHS	AOS,	0	
250	410050071380R	A	XSTR AM9945N-T1-PF N-CH,SO8(AP)RoHS	AP,	0	
260	411020046090R	A	DIO 1N4148W 75V/0.15A(PEC)RoHS SOD-123	PANJIT,	1	D10,
260	411023004021R	B	DIO SN4148-LF 75V/0.15A SMD 1206 (FEC)Ro	FRONTIER,	0	
260	411020046310R	A	DIO 1N4148W-F 75V/0.15A(DIODES RoHS,SOD-	DIODES,	0	
270	411020047210R	A	DIO BAV70 85V SOT23 (PHILIPS) RoHS	PHILIPS,	1	ZD3,
270	411020047090R	A	DIO BAV70, 70V SOT-23(PEC) ROHS	PANJIT,	0	
270	411020047020R	A	DIO BAV70-LF, 70V SOT-23(FEC) ROHS	FRONTIER,	0	
290	491872100000R	A	PCB,CRL-I,2/OSP /FR4 /12,LE17L2	EXPRESS, TOP FAITH,	1	
300	511130002200R	A	SOLDER PASTE,Sn96.5-Ag3.0-Cu0.5 ROHS	TOMAS,	0.13	
300	511130002201R	A	SOLDER PASTE,Sn96.5%Ag3.0%Cu0.5%	TOMAS,	0	
300	511130002202R	A	SOLDER PASTE,Sn95.5%Ag3.9%Cu0.6%	TAMURA,	0	

3. PCBA KEYpad BOM

20080702

ITEM	P/N	Revision	Description	Supplier	Usage	Location
	792211500000R	AA	PCBA,KEYPAD BOARD,LE17M6 ROHS			
10	430602680210R	A	SW METAL DOME 180gf 5P ,RoHS	HUA-JIE,	1	
20	430631080190R		WFR 8P 1.25MM 180° W/LOCK ROHS	JOWLE,FOXCONN	1	CN01,
30		AA	PCBA,KEYPAD BOARD,SMT,LE17M6 ROHS			
40	511130002200R	A	SOLDER PASTE,Sn96.5-Ag3.0-Cu0.5 ROHS	TOMAS,	0.08	
40	511130002201R	A	SOLDER PASTE,Sn96.5%Ag3.0%Cu0.5%	TOMAS,	0	
40	511130002202R	A	SOLDER PASTE,Sn95.5%Ag3.9%Cu0.6%	TAMURA,	0	

20080702

ITEM	P/N	Revision	Description	Supplier	Usage	Location
		AA	PCBA,KEYPAD BOARD,SMT,LE19E6 ROHS			
10	411070093500R	A	LED SMD YB KPTB-1612FX151-SZ(Kingbright)	KINGBRIGHT,	1	LED101,
10	411070094500R	A	LED SMD YB HTL-19-22UYUBC/TR8(HongTong)R	HONGTONG,	0	
20	491921500000R	A	PCB,K/P ,2/ENIG/FR4 /08,LE17M6 ROHS	EXPRESS,	1	
30	414916047250R	A	RES SMD (0603) 4.7k Ω J,RT RoHS	TA-I,UNIOHM,WALSIN,YAGEO,	1	R901

5. Assembly BOM

20080829

ITEM	P/N	Description	Supplier	Usage	Un	Revision
	8171M6A1D030R	E1709W/Y662H/LE17M6-A10/LGD/ANZ				
10	453070801160R	PWRCORD 10A/250V BLK 8FT SAA GFC-3R1.0mm	I-SHENG, LONGWELL,	1	PC	A
20	453010100320R	CABLE D-SUB 15P MALE 6FT BLACK/BLUE AB 8	FOXCONN, HOTRON, JVE, 廣宇,	1	PC	B
50	7140727A0000R	ASSY, FIANL(B)W/O SPK, LE17M6-A10(DAO/E170		1	PC	A
60	713100009305R	ASSY, PACKAGE, PACK, ANZ, LE17M6		1	PC	A

20080829

ITEM	P/N	Description	Supplier	Usage	Un	Revision
	713100009305R	ASSY, PACKAGE, PACK, ANZ, LE17M6				A
10	506140006400R	LABEL, BARCODE, LE17M6	高綺, 鍵升,	1	PC	A
20	506250027300R	LABEL, AGENCY, LE17M6	高綺, 鍵升,	1	PC	A
30	506431007000R	FILM, SCREEN, PROTECTION, PRINTED, LE17M6	柏興, 鴻旺,	1	PC	A
40	506380001400R	TAPE 3M-897 12x45000mm	久威, 矽威,	0.00333	ROL	A
50	506280009001R	POSTER, QUICK SETUP, EAST, LE17M6	裕同, 鴻達,	1	PC	A
60	703500009702R	KIT, ACCESSORY, DOC, APCC, LE17M6	裕同, 鴻達,	1	PC	A
70	506120009300R	BAG, PLASTIC, L300xW250mm(PRINTED), LE19D5	柏興, 鴻旺,	1	PC	B
80	506120009310R	BAG, PLASTIC, L550xW550mm(PRINTED), LE19D5	柏興, 鴻旺,	1	PC	A
90	506020029400R	CARTON, DELL(WWW), LE17M6	佳藝, 美盈森,	1	PC	A
100	506060014210R	CUSHION TOP, LE17M6	宜盛, 東揚,	1	PC	A
110	506060014200R	CUSHION BOTTOM, LE17M6	宜盛, 東揚,	1	PC	A
120	506340004700R	LABEL BLANK 101X50mm DELL EMEA CARTON	高綺, 鍵升,	1	PC	A
130	506380002622R	TAPE, WRAPPING TYPE PRINTED(DEL), BLACK	佳普森,	0.00133	ROL	A
140	713010005300R	ASSY PACK, 20STD, LE17M6		1	PC	A
140	713010005301R	ASSY PACK, 40STD, LE17M6		0	PC	A
140	713010005302R	ASSY PACK, 40HQ, LE17M6		0	PC	A
140	713010005303R	ASSY PACK, AIR CARGO(20STD), LE17M6		0	PC	A
140	713010005304R	ASSY PACK, AIR CARGO(40STD), LE17M6		0	PC	A

20080826

ITEM	P/N	Description	Supplier	Usage	Un	Revision
	7140727A0000R	ASSY, FIANL(B)W/O SPK, LE17M6-A10(DAO/E170				A
10	509212103500R	SCREW, F, CROSS, T.T-2*3, BLK	高億,	4	PC	A
20	509116610510R	SCREW, P, CROSS, M4*10, BLACK-NL(NYLOK)	立侑, 高億,	3	PC	A
30	714050020000R	ASSY BACK COVER ,LE17M6, Black	MMP,	1	PC	A
40	714020017100R	ASSY STAND ,LE17M6	富鴻齊,	1	PC	A
50	714030021300R	ASSY, FRONT, BEZEL, LE17M6, Black	MMP,	1	PC	A
60	7140827A0000R	ASSY, PANEL, W/O SPK, LE17M6-A10(E1709W)		1	PC	A

20080826

ITEM	P/N	Description	Supplier	Usage	Un	Revision
	713010005300R	ASSY PACK, 20STD, LE17M6				A
10	506432001900R	SLIP SHEET, L1150xW990xH100mm, LE1911	SUNSTREAM,	0.02009	PC	A
20	506037011000R	CARDBOARD, COVER, L1146xW988xH100xT3mm, LE1	佳藝, 美盈森,	0.04017	PC	A



30	506039008800R	CORNER PAPER 1060x50x50xT3mm LE1963	佳藝,	0.05623	PC	A
40	506039007210R	CORNER PAPER 1200x50x50xT3mm LE1718	佳藝,金惠,	0.0241	PC	A
50	506431000300R	FILM,PE 500mmx900M ROHS	三輝,柏興,	0.00178	ROL	A
60	506120400100R	BAG AIR DUNNAGE 2000x1000mmLE1X03 ROHS	SISUN,	0.00101	PC	A
70	506380002612R	TAPE,WRAPPING TYPE,50Mx82mm	佳普森,	0.00026	ROL	A

20080826

ITEM	P/N	Description	Supplier	Usage	Un	Revision
	713010005301R	ASSY PACK,40STD,LE17M6				A
10	506432001900R	SLIP SHEET,L1150xW990xH100mm, LE1911	SUNSTREAM,	0	PC	A
20	506037011000R	CARDBOARD,COVER,L1146xW988xH100xT3mm,LE1	佳藝,美盈森,	0	PC	A
30	506039008800R	CORNER PAPER 1060x50x50xT3mm LE1963	佳藝,	0	PC	A
40	506039007210R	CORNER PAPER 1200x50x50xT3mm LE1718	佳藝,金惠,	0	PC	A
50	506431000300R	FILM,PE 500mmx900M ROHS	三輝,柏興,	0	ROL	A
60	506380002612R	TAPE,WRAPPING TYPE,50Mx82mm	佳普森,	0	ROL	A

20080826

ITEM	P/N	Description	Supplier	Usage	Un	Revision
	713010005302R	ASSY PACK,40HQ,LE17M6				A
10	506432001900R	SLIP SHEET,L1150xW990xH100mm, LE1911	SUNSTREAM,	0	PC	A
20	506037011000R	CARDBOARD,COVER,L1146xW988xH100xT3mm,LE1	佳藝,美盈森,	0	PC	A
30	506039007210R	CORNER PAPER 1200x50x50xT3mm LE1718	佳藝,金惠,	0	PC	A
40	506039006100R	CORNER PAPER 1250x50x50xT3mm LE963 ROH	佳藝,	0	PC	A
50	506431000300R	FILM,PE 500mmx900M ROHS	三輝,柏興,	0	ROL	A
60	506380002612R	TAPE,WRAPPING TYPE,50Mx82mm	佳普森,	0	ROL	A

20080826

ITEM	P/N	Description	Supplier	Usage	Un	Revision
	713010005303R	ASSY PACK,AIR CARGO(20STD),LE17M6				A
10	506150002620R	PALLET L1150xW990xH120mm LE1911	實習工廠,	0	PC	B
20	506037011000R	CARDBOARD,COVER,L1146xW988xH100xT3mm,LE1	佳藝,美盈森,	0	PC	A
30	506039008700R	CORNER PAPER 900x50x50xT3mm LP1704	金惠,	0	PC	A
40	506039001400R	CORNER PAPER 200x50x50mm ROHS	佳藝,金惠,	0	PC	A
50	506431000300R	FILM,PE 500mmx900M ROHS	三輝,柏興,	0	ROL	A
60	506120400100R	BAG AIR DUNNAGE 2000x1000mmLE1X03 ROHS	SISUN,	0	PC	A
70	506380002612R	TAPE,WRAPPING TYPE,50Mx82mm	佳普森,	0	ROL	A

20080826

ITEM	P/N	Description	Supplier	Usage	Un	Revision
	713010005304R	ASSY PACK,AIR CARGO(40STD),LE17M6				A
10	506150002620R	PALLET L1150xW990xH120mm LE1911	實習工廠,	0	PC	B
20	506037011000R	CARDBOARD,COVER,L1146xW988xH100xT3mm,LE1	佳藝,美盈森,	0	PC	A
30	506039008700R	CORNER PAPER 900x50x50xT3mm LP1704	金惠,	0	PC	A
40	506039001400R	CORNER PAPER 200x50x50mm ROHS	佳藝,金惠,	0	PC	A
50	506431000300R	FILM,PE 500mmx900M ROHS	三輝,柏興,	0	ROL	A
60	506380002612R	TAPE,WRAPPING TYPE,50Mx82mm	佳普森,	0	ROL	A

20080826

ITEM	P/N	Description	Supplier	Usage	Un	Revision
	714020017100R	ASSY STAND ,LE17M6				A
10	501260211500R	STAND-ARM,LE17M6	富鴻齊,	1	PC	A
20	501260211501R	STAND-BASE,LE17M6	富鴻齊,	1	PC	A

20080826

ITEM	P/N	Description	Supplier	Usage	Un	Revision
	714030021300R	ASSY,FRONT,BEZEL,LE17M6,Black				A
10	501010222500R	FRONT,BEZEL,LE17M6,Black		1	PC	A
20	750020200200R	SUB-ASSY,BUTTON,LE17M6		1	PC	A
30	501120110100R	POWER BUTTON LENS, LE17M6, DARK SMOKED		1	PC	A
40	501110100110R	Dell-logo-KW265,LE19E6		1	PC	A

20080826

ITEM	P/N	Description	Supplier	Usage	Un	Revision
	714050020000R	ASSY BACK COVER ,LE17M6,Black				A
10	501020226500R	BACK COVER ,LE17M6,Black		1	PC	A
20	502210100300R	KENSINGTON LOCK LP1703 ROHS		1	PC	A

20080826

ITEM	P/N	Description	Supplier	Usage	Un	Revision
	7140827A0000R	ASSY,PANEL,W/O SPK,LE17M6-A10(E1709W)				A
10	631102072910RD	LCP 17" LM171WX3-TLC2(A)(LPL)ROHS		1	PC	A
20	792211300A00R	PCBA,I/F BOARD,W/O SPK,LE17M6-A10 ROHS		1	PC	AA
30	792211400A00R	PCBA,P/I BOARD,W/O SPK,LE17M6-A10 ROHS		1	PC	AA
40	792211500000R	PCBA,KEYPAD BOARD,LE17M6 ROHS		1	PC	AA
50	430300801920R	HRN ASSY 2x4P to8P 353mm UL1571#28	FOXCONN,JVE,	1	PC	A
60	430303001930R	HRN LVDS FFC 30P 166mm	P-TWO,	1	PC	A
70	509146306202R	SCREW,P,CROSS,W/WAS(7.8),M3*6,Zn-Cc	卓越,高億,	4	PC	A
80	509446309100R	SCREW,B,CROSS,W/W-SPR,M3*9,Zn,ROHS	HUAMAO,卓越,	1	PC	A
90	509016304200R	SCREW,I,CROSS,M3*4,Zn-CcROHS	高億,鴻益進,	4	PC	A
100	509016306200R	SCREW,I,CROSS,M3*6,Zn-Cc	高億,	2	PC	A
110	509000001000R	BOLT,#4-40x12.5,Ni ROHS	高億,	2	PC	A
120	505040210300R	Chassis-Mylar,LE17M6	富准,	1	PC	A
130	701000012401R	ASSY CHASSIS for LG PANEL,LE17M6	MMP,	1	PC	A
140	506380001730R	TAPE ACE 85x20mm LE1913	久威,	1	PC	A

20080826

ITEM	P/N	Description	Supplier	Usage	Un	Revision
	701000012401R	ASSY CHASSIS for LG PANEL,LE17M6				A
10	502090314601R	CHASSIS for LG PANEL,LE17M6		1	PC	A
20	502040400600R	SHIELD EMI LP2207		2	PC	A

20080826

ITEM	P/N	Description	Supplier	Usage	Un	Revision
	750020200200R	SUB-ASSY,BUTTON,LE17M6				A
10	501030212300R	BUTTON,LE17M6		1	PC	A

Attachment 2- Schematic

1. Interface board schematic

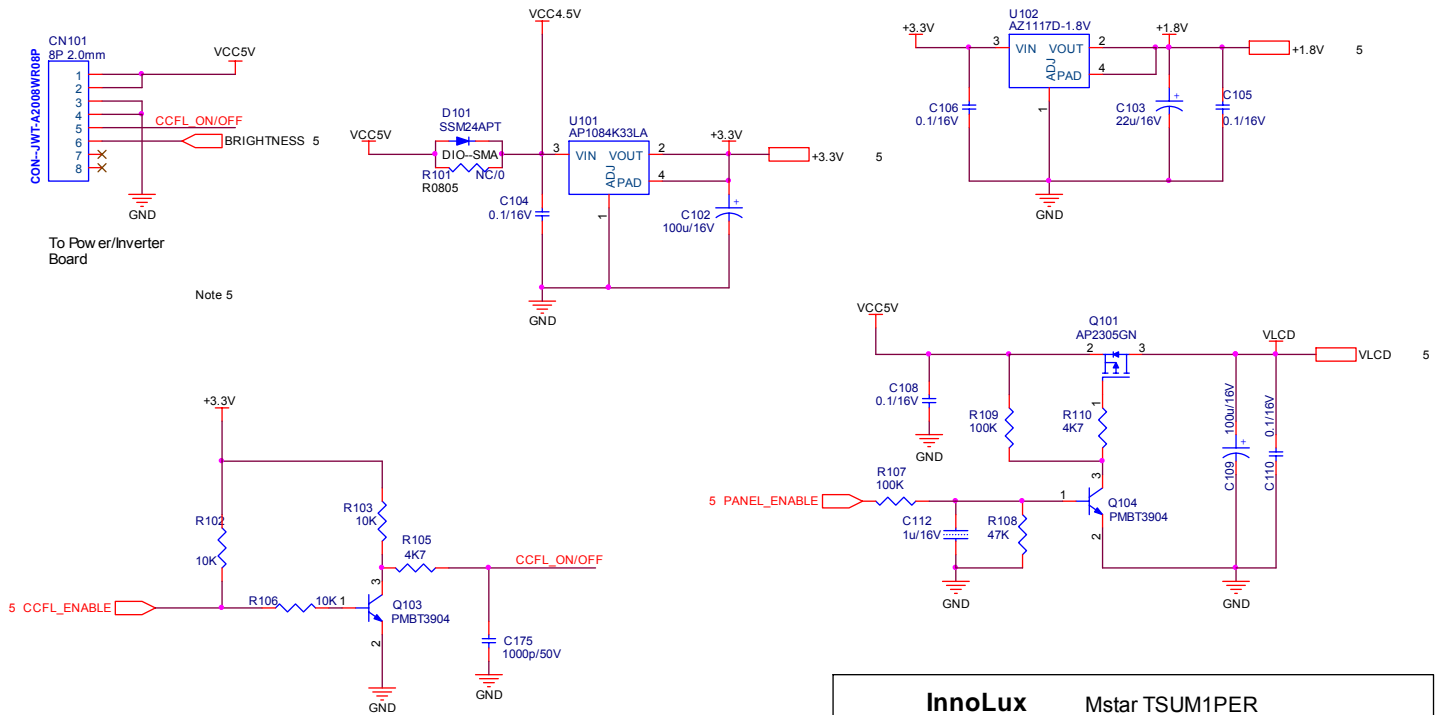

InnoLux		Mstar TSUM1PER	
Document Number :	DELL E1709W	SIZE :	A4
TITLE :	VGA-INPUT		CHECK BY :
DATE :	2008-6-5		DRAWN BY :
SHEET	3 OF 7	Rev :	V02

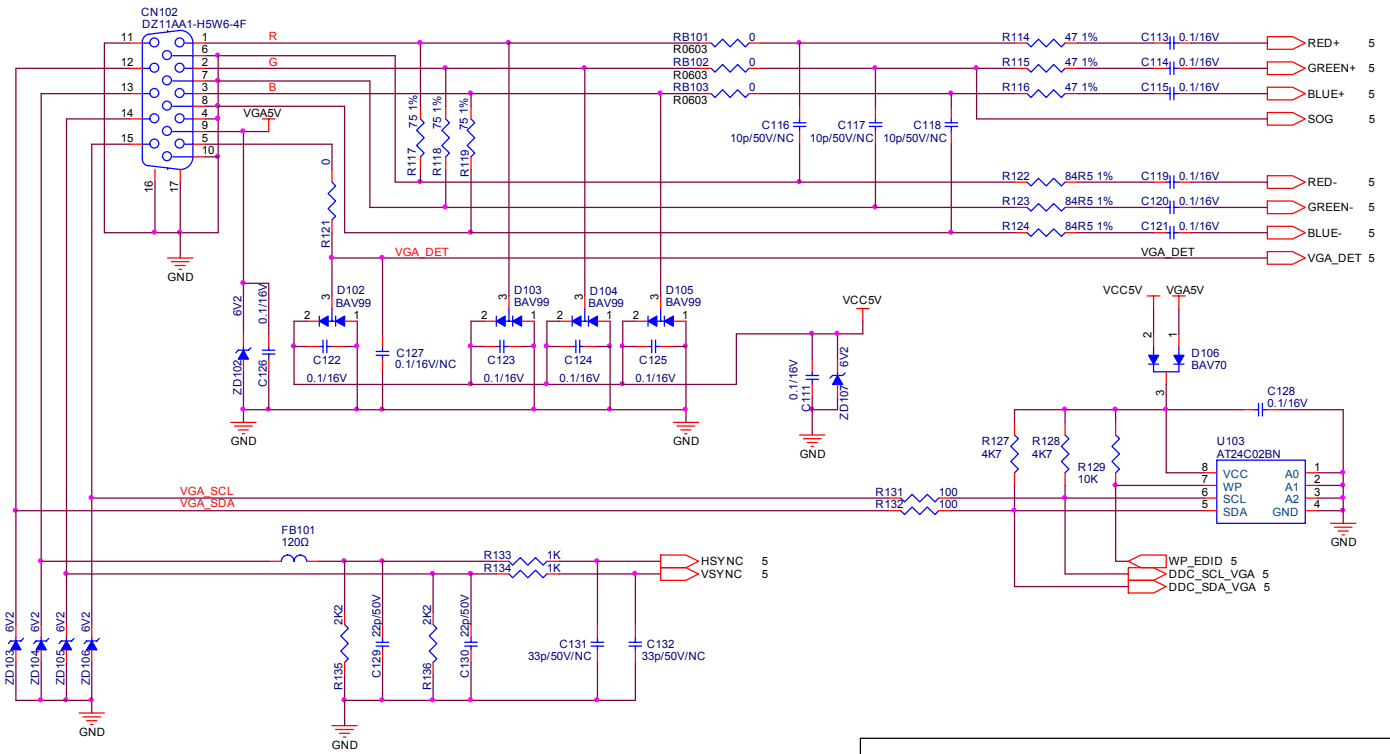

InnoLux		Mstar TSUM1PER	
Document Number :	DELL E1709W	SIZE :	A4
TITLE :	VGA-INPUT	APPRO BY :	
DATE :	2008-6-5	CHECK BY :	
SHEET	4 OF 7	Rev :	V02
		DRAWN BY :	

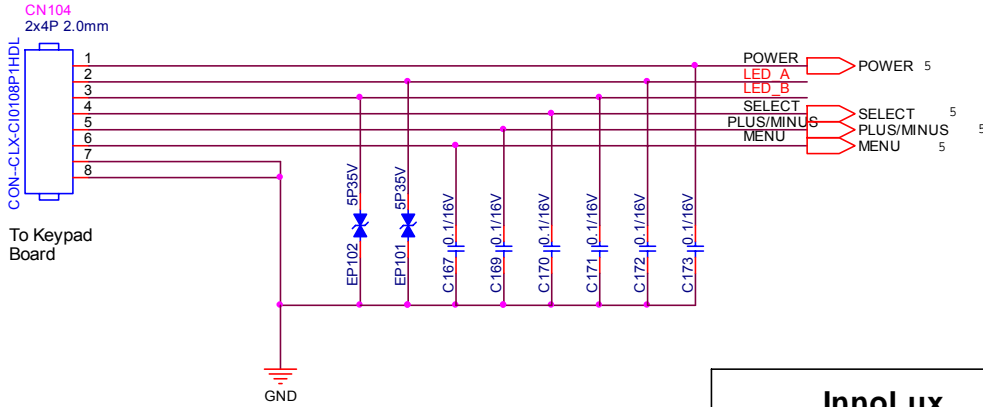
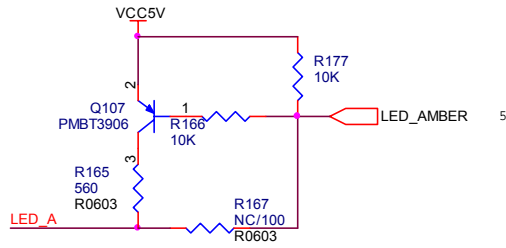
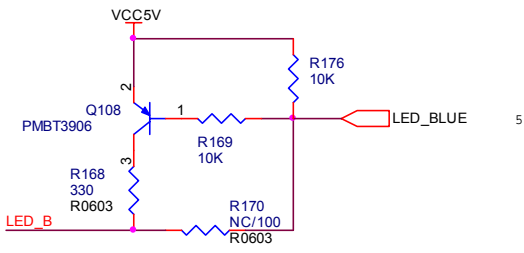

ADC Key	
PLUS	0V
MINUS	1.06V

InnoLux		E1709W	
Document Number : E1709W		SIZE : A	APPRO BY :
TITLE : Keypad			CHECK BY :
DATE : 2008-06-05			DRAWN BY :
SHEET	6	OF	7
			Rev : V02

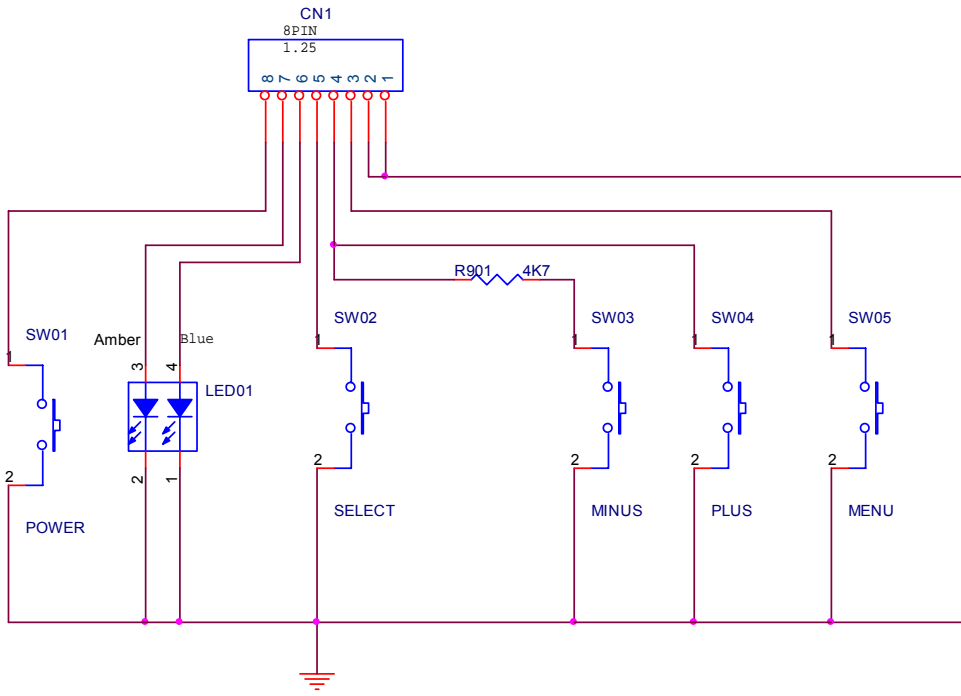

InnoLux		E1709W	
Document Number :	E1709W	SIZE :	A
TITLE :			APPRO BY :
Keypad			CHECK BY :
DATE :	2008-06-05	DRAWN BY :	
SHEET	7 OF 7	Rev :	V01

DELL 1709W Power/Inverter
Schematic Diagram

LP/LHSD PANEL

SCHEMATIC	SHEET
1.0 Contents	1
1.1 Inverter DC to AC BD	2
1.2 Inverter Control BD	3
1.3 Power AC to DC	4
1.4 Power Control BD LD7575	5
1.5 Power 12V Rectifier BD	6

2. Power board schematic

Title		DELL 1709W power&inverter	
Size	Document Number	Rev	
A4	<Doc>	R2	
Date:	Friday, August 29, 2008	Sheet	1 of 6

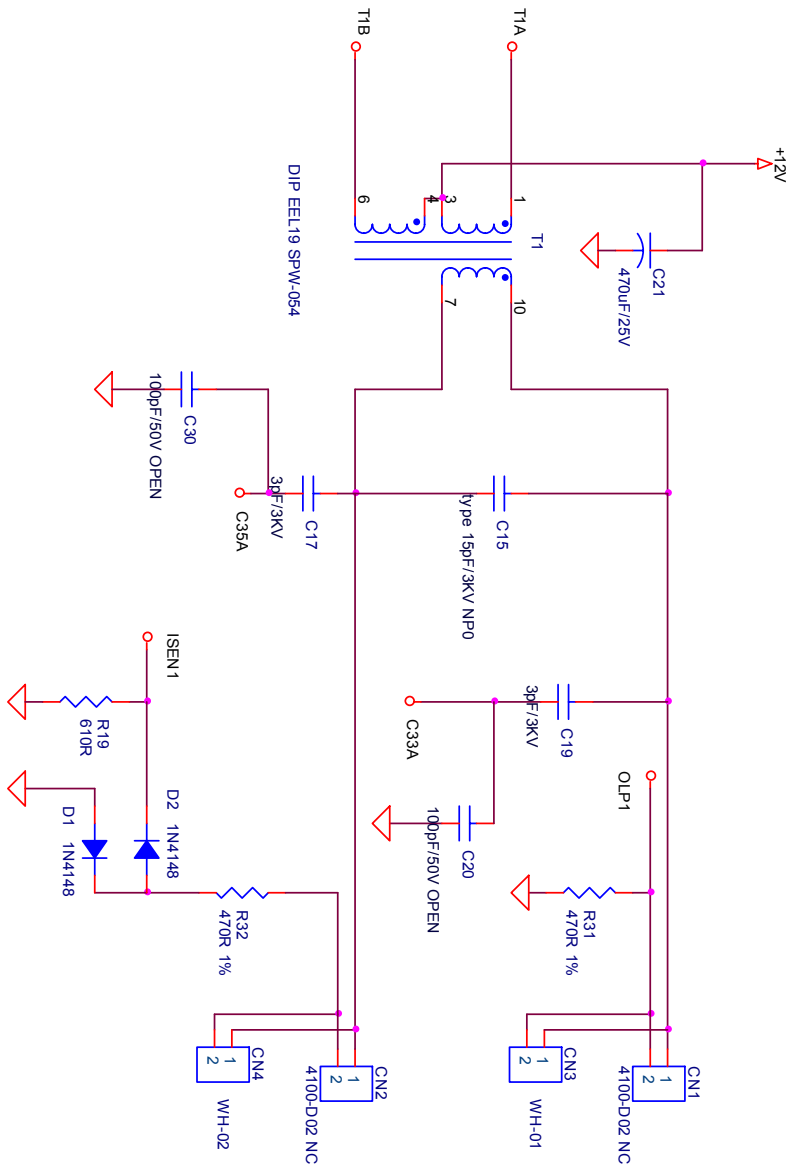
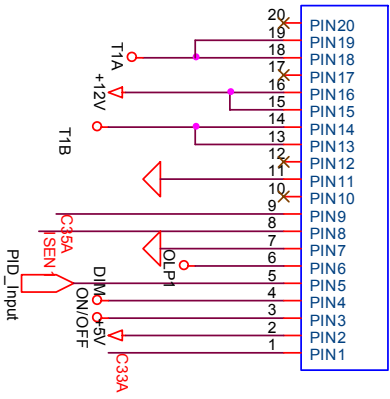
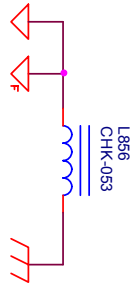
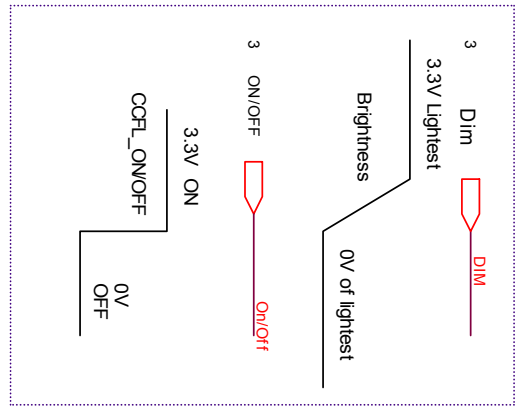

Title		2 CCFL Inverter DC to AC	
Size	Document Number	Rev	
A4		R2	
Date:	Friday, August 29, 2008	Sheet	2 of 6

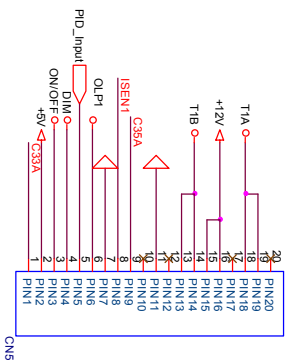
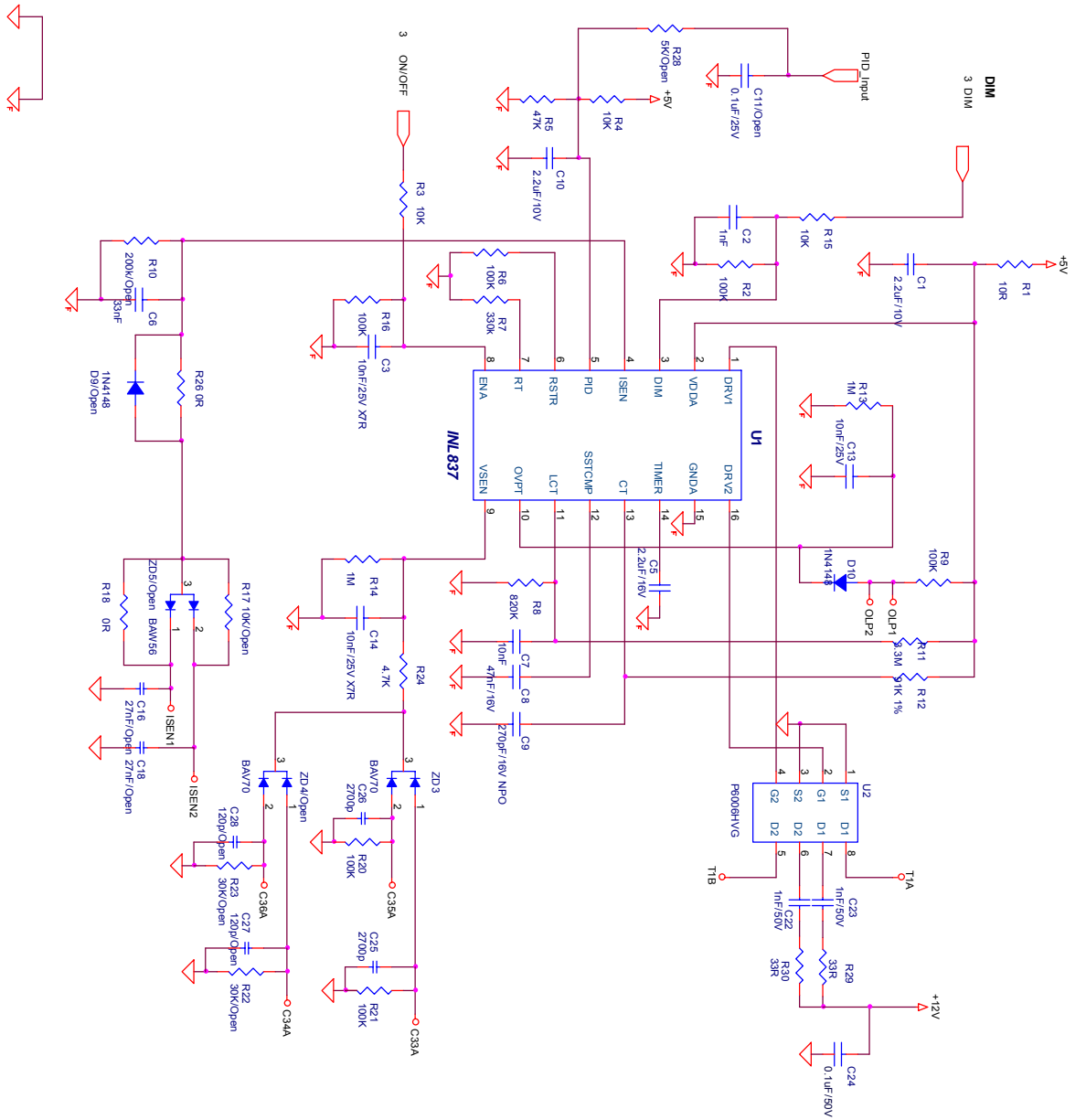

Title		Dell 1709W Inverter control board	
Size	AS	Document Number	Rev
Date	Friday, August 29, 2008	Sheet	3 of 6

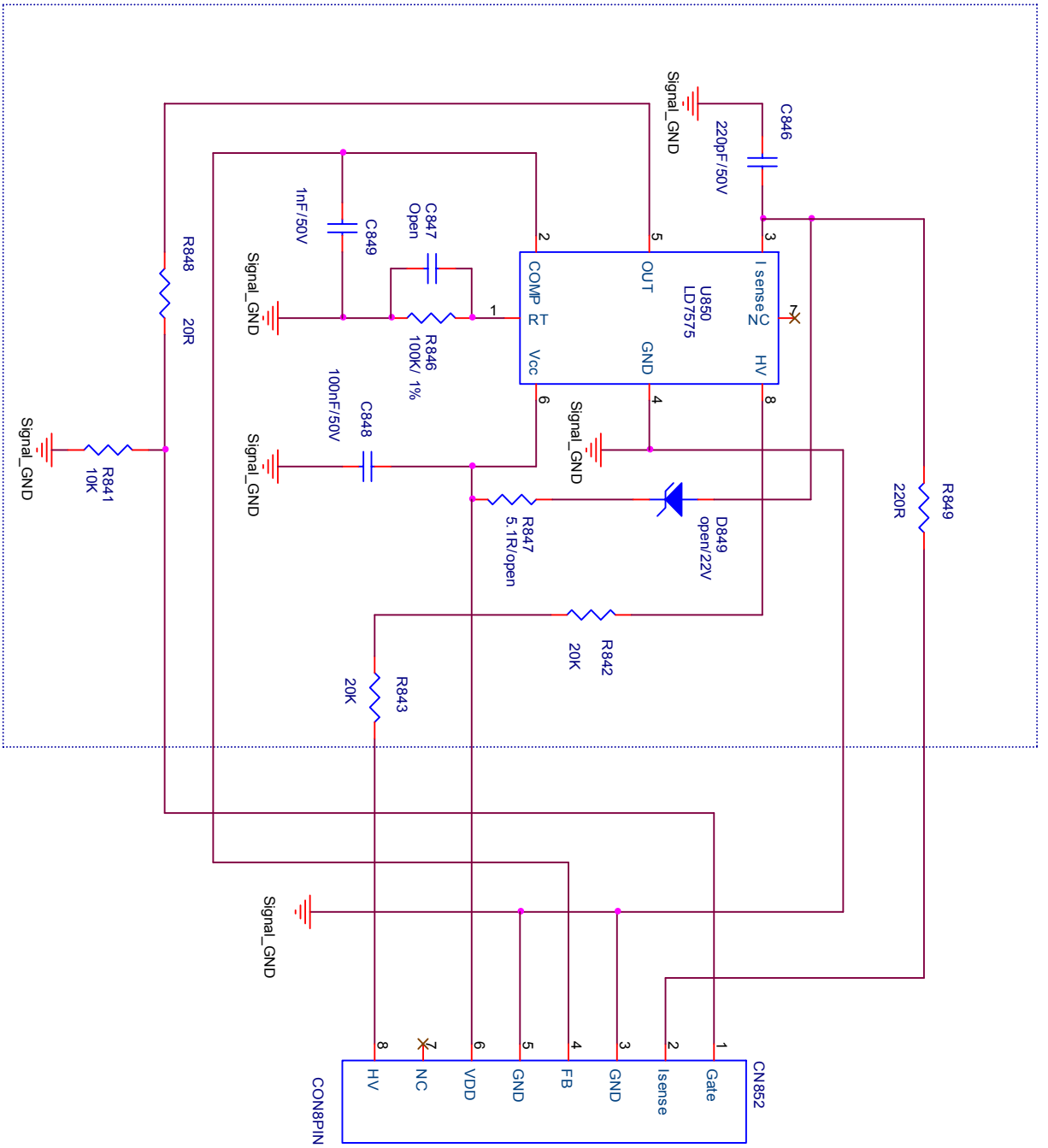

Title		Power control BD LD7575
Size		A4
Date:		Friday, August 29, 2008
Document Number	Sheet	5 of 6
Rev		R2

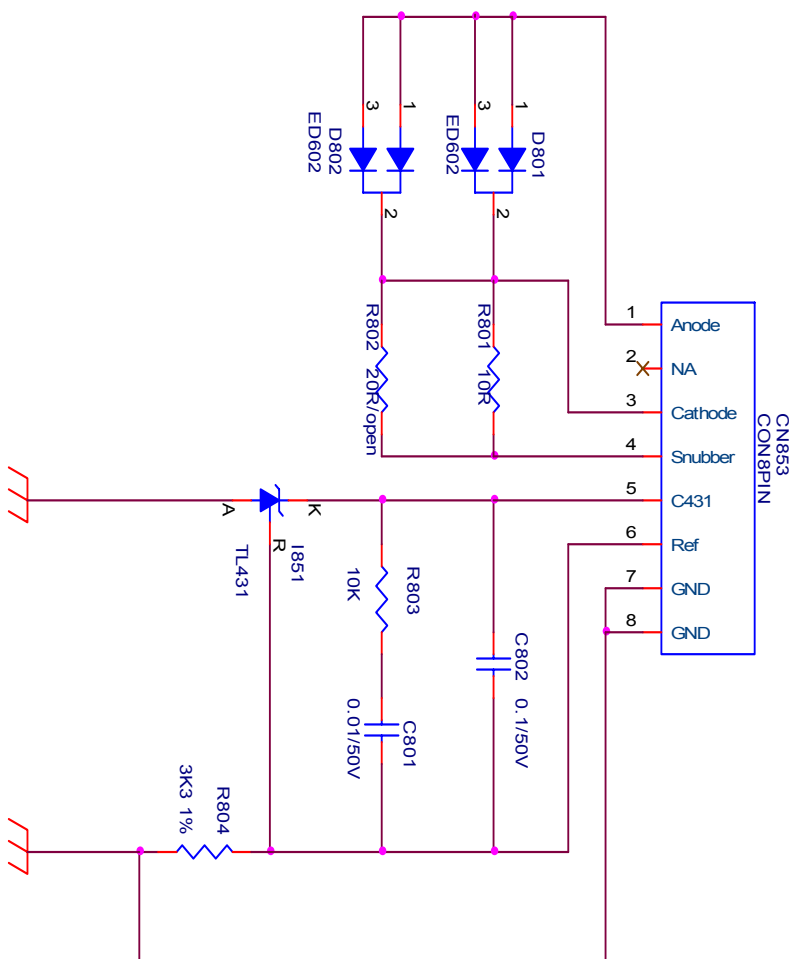

Title		Power 12V Rectifier BD	
Size	Document Number	Rev	
A4	<Doc>	R2	
Date:	Friday, August 29, 2008	Sheet	6 of 6

Attachment 3- PCB Layout power/inverter bd:

Power/inverter bd:

Top Layer

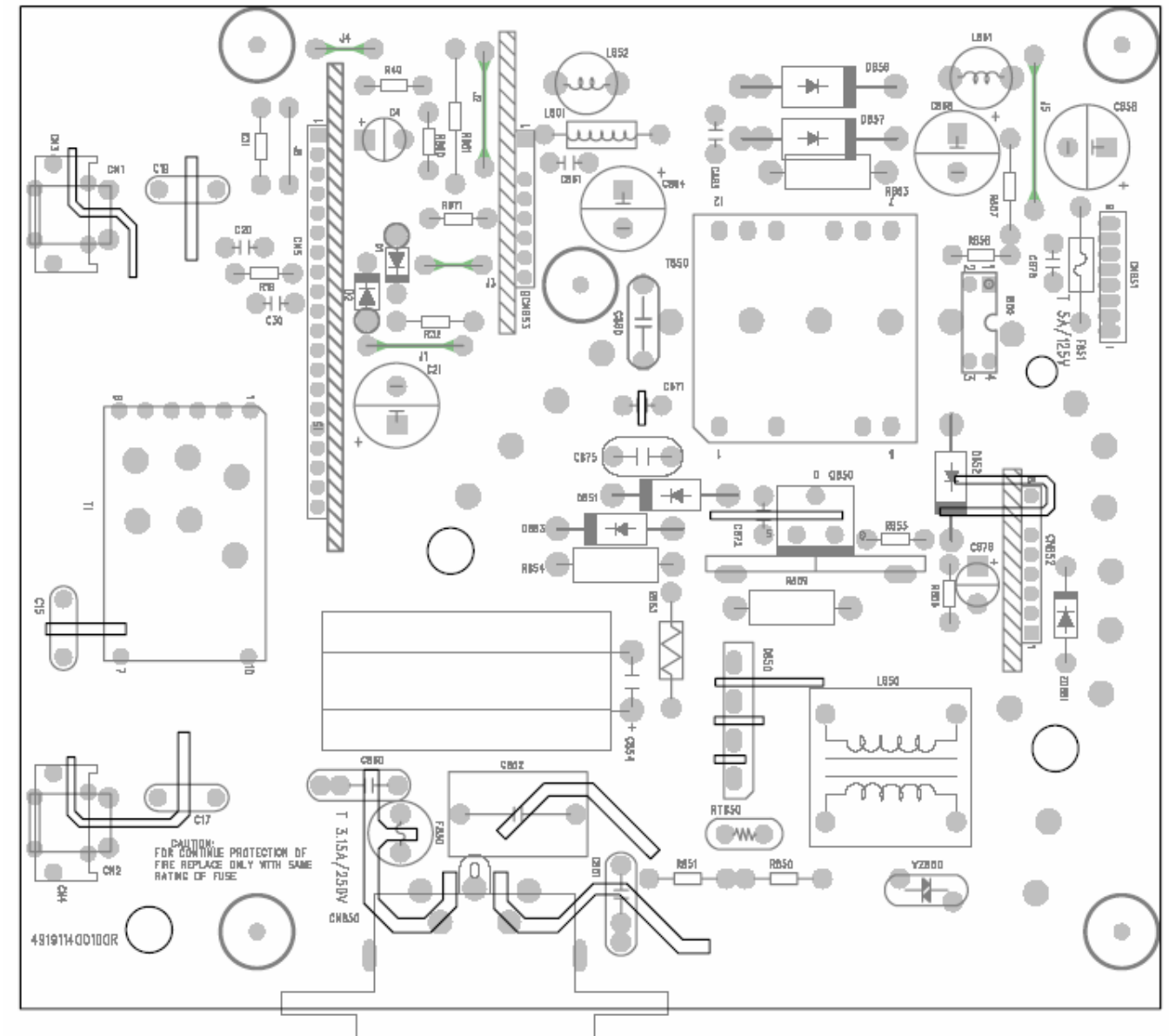

LAYER	DRIFTDRAWING
-------	--------------

Bottom Layer

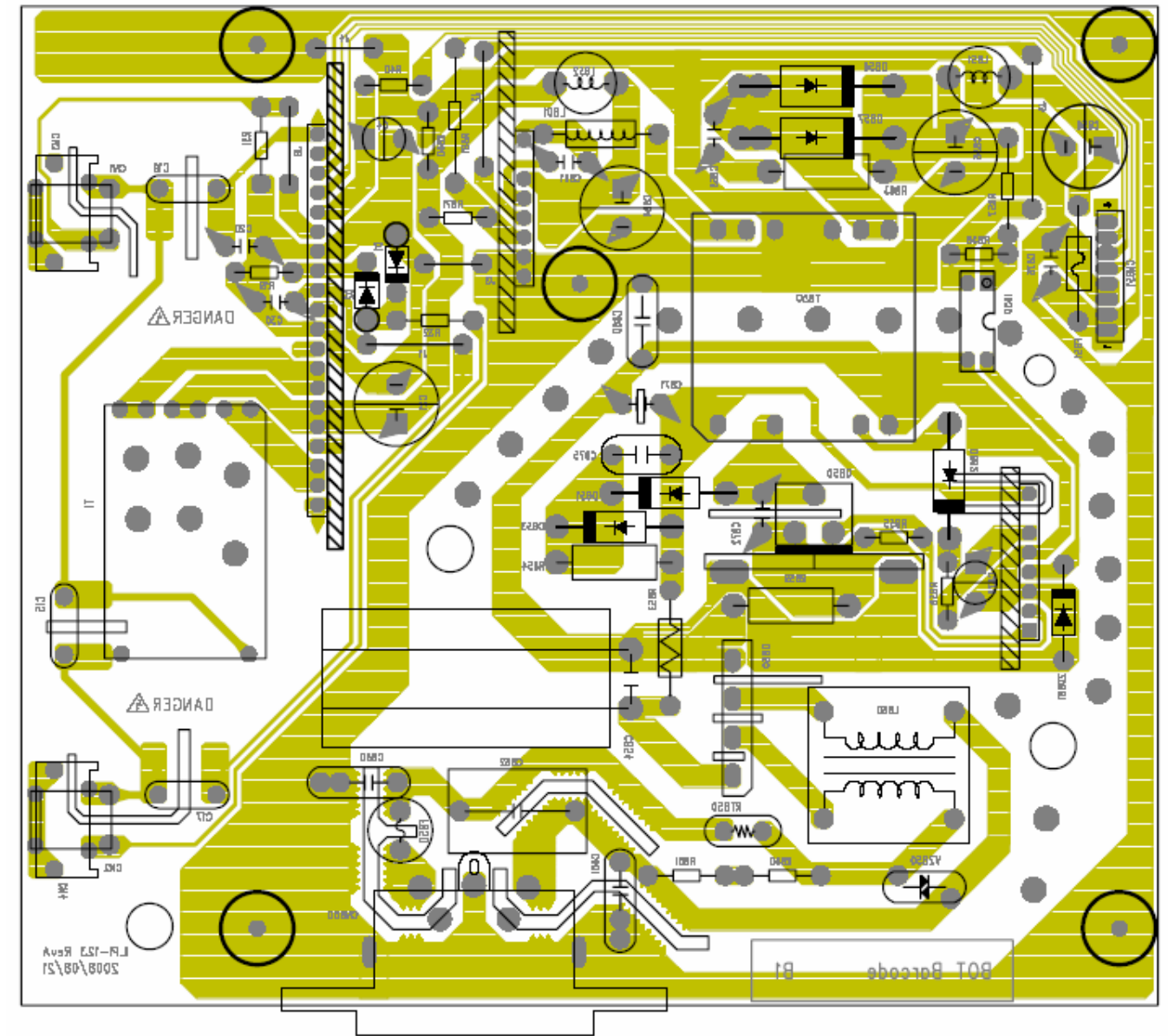

FOXCONN	LAYER	SILKSCREEN BOTTOM			
	PCB NO	491911400100R	REV	A	DESIGNER: Inkai Qiu
	FILE NO	ILPI-123	REMARK	2008/08/21	

**I/F board:
Top Layer**

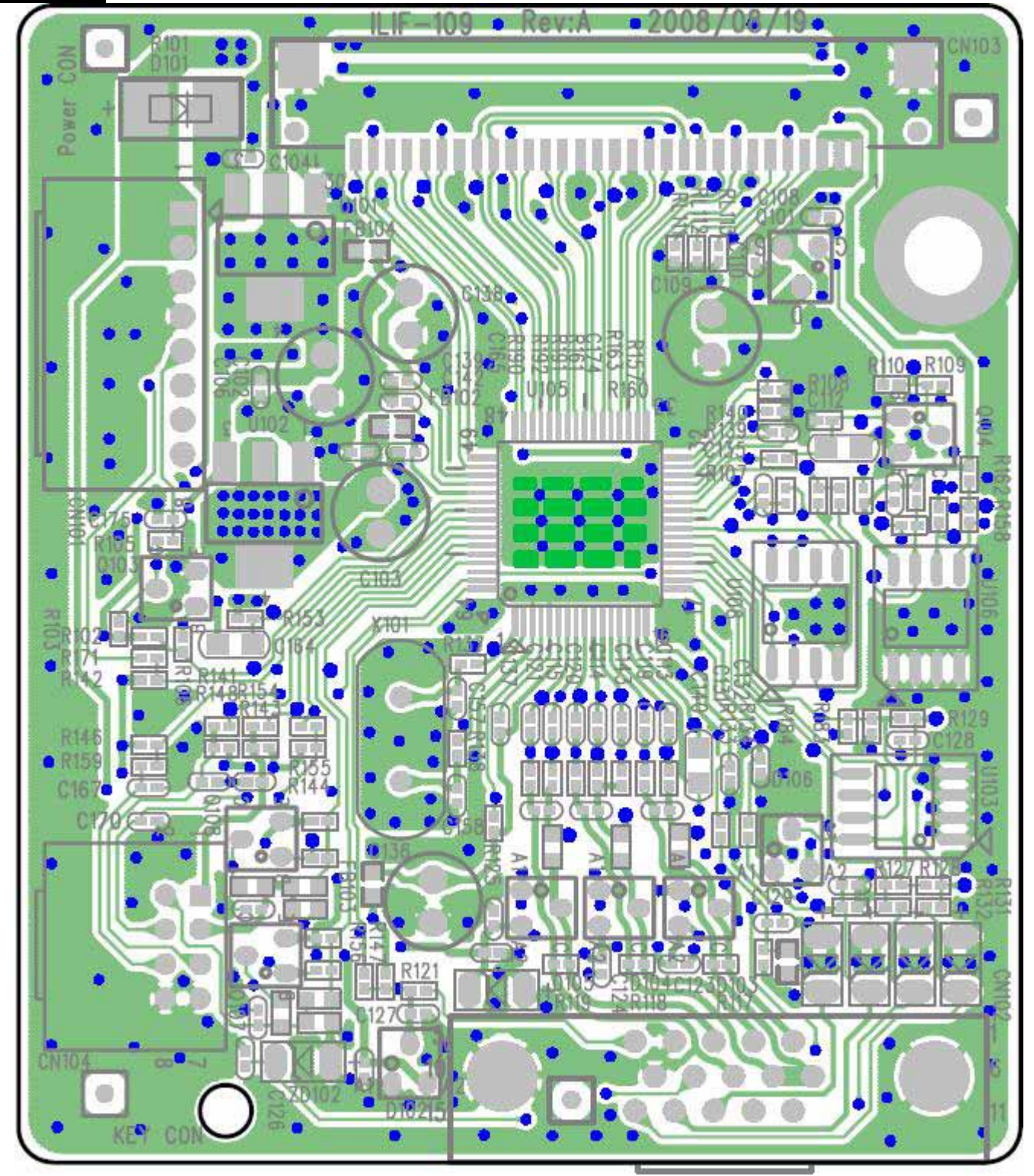

Bottom Layer

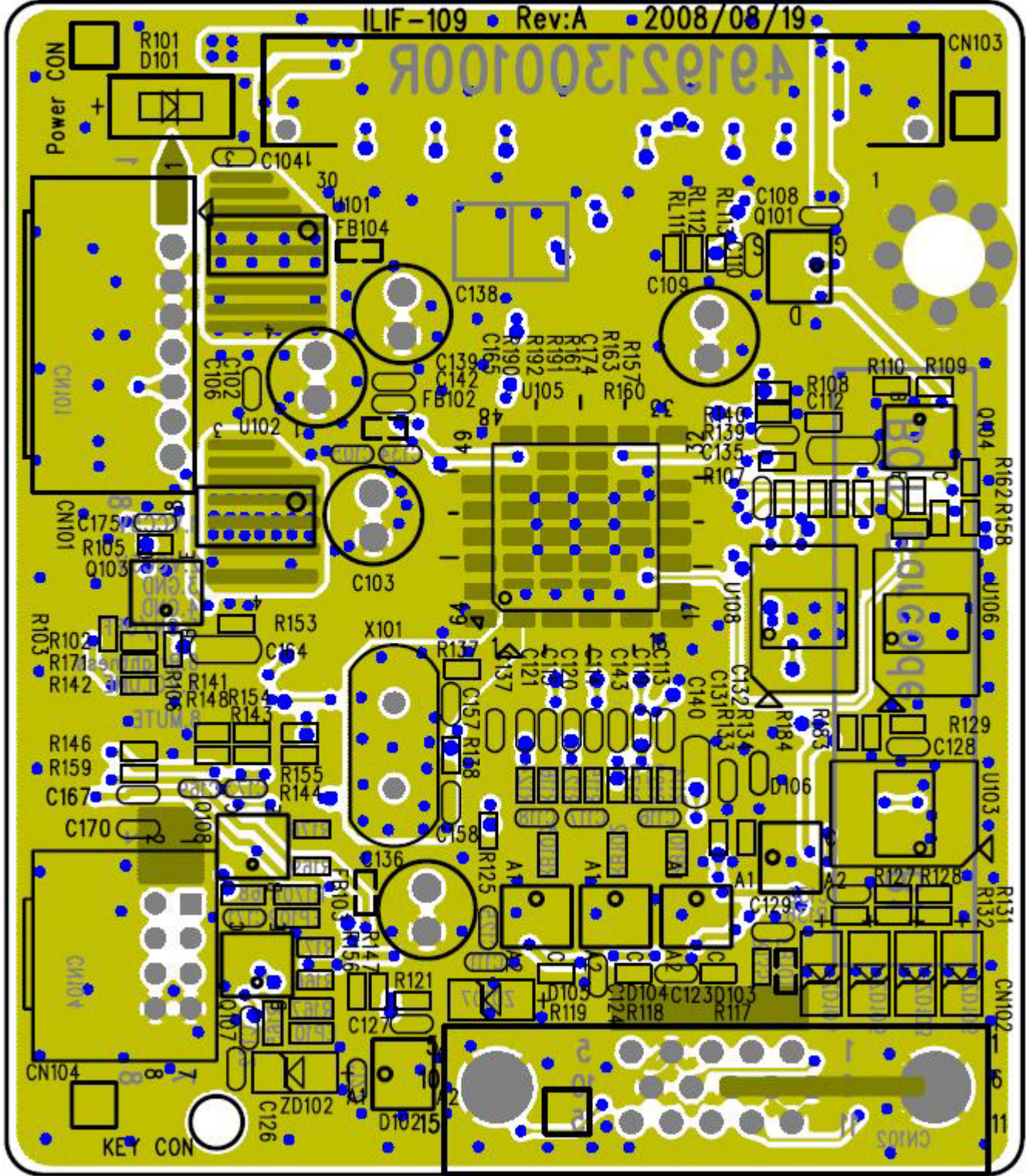

**Keypad:
Top Layer**

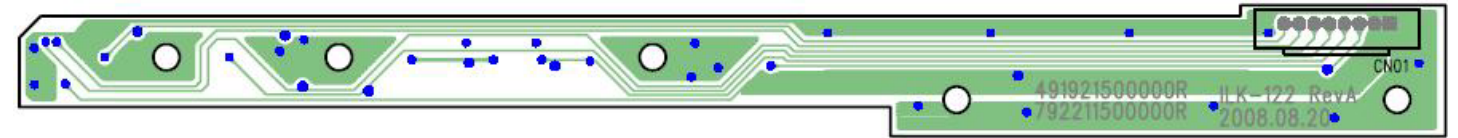

Bottom Layer

