



OPERATOR AND PARTS MANUAL

Hydraulic Snowblower

Model 6025, 7225, 7235, 8425, & 8435

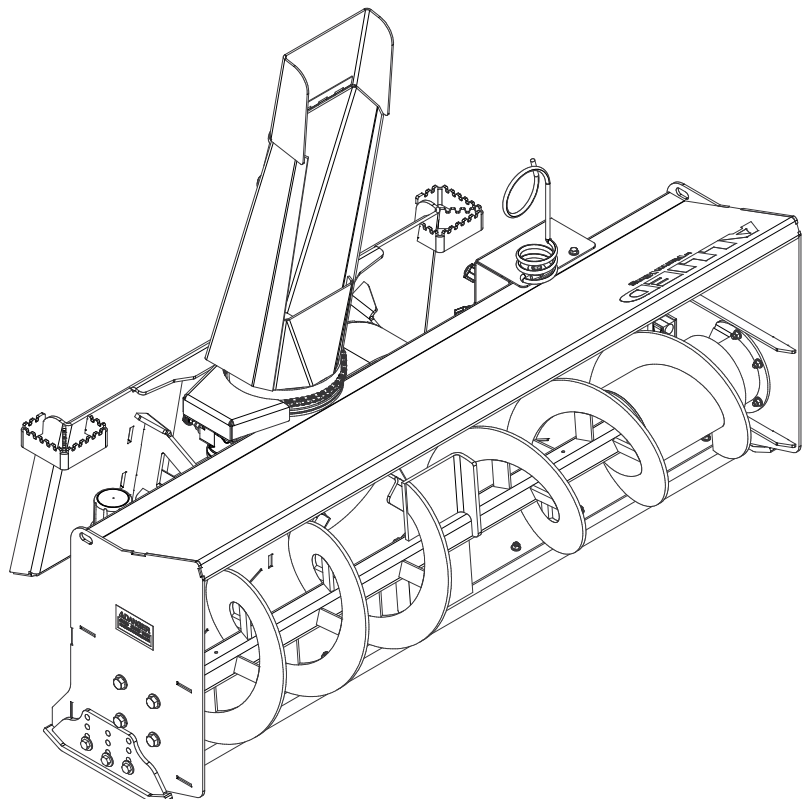

Table of Contents

- Introduction4**
- Safety.....5**
 - Safety5
 - General Safety6
 - Start-up Safety6
 - Operation Safety6
 - Transport Safety7
 - Service and Maintenance Safety7
 - Storage Safety7
 - Safety Signs8
 - Safety Sign Installation8
- Assembly..... 10**
 - Assembly Instructions 10
- Start-up and Operation Instructions..... 12**
 - Theory of Operation 13
- Specifications..... 14**
- Bolt Torque 16**
 - Checking Bolt Torque 16
- Troubleshooting..... 17**
- Parts Drawings..... 18**
 - Hydraulic Snowblower Drawing - All Models 18
 - Hydraulic Snowblower Parts List - All Models20
 - Hose Assembly - Model 60" SF.....22
 - Hose Assembly - Model 72" SF.....23
 - Hose Assembly - Model 72" HF.....24
 - Hose Assembly - Model 84" SF.....25
 - Hose Assembly - Model 84" HF.....26
 - Manifold.....28
- Shipping Kit and Bundle Numbers30**
- Hole Locations for Width Extendor Kits31**
- Maintenance32**
- Hydraulic Snowblower Wiring Schematic 816225 - Optional32
- Pictorial References34**
- Warranty36**

Manufacturer’s statement: for technical reasons Buhler Industries Inc. reserves the right to modify machinery design and specifications provided herein without any preliminary notice. Information provided herein is of descriptive nature. Performance quality may depend on soil fertility, applied agricultural techniques, weather conditions and other factors.

Introduction

For more than a generation, Allied has been building the most popular snowblowers used on farms, airports, and municipalities throughout the North American snow-belt. Now, all that experience brings you the rugged hydraulic snowblowers to handle more demanding snow clearing jobs.

The Allied Hydraulic Snowblower is offered in three main sizes: 60", 72" and 84". The 72" and 84" sizes are also made available in a higher capacity version for use on equipment with high flow hydraulic systems. These models are best suited for the more demanding snow clearing jobs with their increased cutting height, larger diameter auger and fan, and increased throwing capacity. As an option, standard flow (SF) and high flow (HF) width extension kits are offered to increase the cutting width of any model by 6" (15.2 cm).

The rugged design of the Allied Hydraulic Snowblower is meant to provide many years of trouble-free operation. The direct drive auger and fan means there are no drive chains, U-joints, or driveshafts in key areas that need lubrication, adjusting, or replacing. The cutting edge and skid shoes provide for simple bolt on replacements. The hydraulic system is designed for efficient operation without requiring any adjustments, provided that a 20.7 GPM flow rate is supplied at 3300 psi for SF models, and a 37 GPM flow rate is supplied at 3300 psi for HF models. The remote in-cab control with supplied wiring harness allows the operator to conveniently control the snow discharge path during operation.

Keep this manual handy for frequent reference. All new operators or owners must review the manual before using the equipment and at least annually thereafter. Contact your Allied Dealer if you need assistance, information, or additional copies of the manual. Visit our website at www.farm-king.com for a complete list of dealers in your area.

The directions left, right, front and rear, as mentioned throughout this manual, are as seen facing in the direction of travel of the implement.

Safety

Safety Instructions

Remember, YOU are the key to safety. Good safety practices not only protect you, but also the people around you. Make these practices a working part of your safety program. Be certain that everyone operating this equipment is familiar with the recommended operating and maintenance procedures and follows all the safety precautions. Most accidents can be prevented. Do not risk injury or death by ignoring good safety practices.

The alert symbol is used throughout this manual. It indicates attention is required and identifies hazards. Follow the recommended precautions.



The safety alert symbol means...
ATTENTION! BECOME ALERT! YOUR SAFETY IS INVOLVED!



CAUTION

The caution symbol indicates a potentially hazardous situation that, if not avoided, may result in minor or moderate injury. It may also be used to alert against unsafe practices.



WARNING

The Warning Symbol indicates a potentially hazardous situation that, if not avoided, could result in death or serious injury, and includes hazards that are exposed when guards are removed. It may also be used to alert against unsafe practices.



DANGER

The Danger Symbol indicates an imminently hazardous situation that, if not avoided will result in death or serious injury. This signal word is to be limited to the most extreme situations, typically for machine components that, for functional purposes, cannot be guarded.

General Safety Instructions

- Have a first-aid kit available for use and know how to use it.
- Have a fire extinguisher available, stored in a highly visible location, and know how to use it.
- Wear appropriate protective gear. This list may include but is not limited to:
 - hard hat
 - protective shoes with slip resistant soles
 - protective glasses or goggles
 - heavy gloves
 - wet weather gear
 - hearing protection
 - respirator or filter mask
- Read and understand the Operator's Manual and all safety signs before operating, servicing, adjusting, repairing, or unplugging the equipment.
- Do not attempt any unauthorized modifications to your Allied by Farm King product as this could affect function or safety, and could affect the life of the equipment.
- Never start or operate the snowblower except from the operator's station on the power unit.
- Inspect and clean the working area before operating.
- Keep hands, feet, clothing, and hair away from moving parts.
- Ensure bystanders are clear of the area before operating.

Start-Up Safety

- Do not let inexperienced operators or children run this equipment.
- Place all tractor and machine controls in neutral before starting.
- Operate only with ROPS and seatbelt equipped tractors.
- Do not operate inside a building unless there is adequate ventilation.
- Ensure all shields are in place and in good condition before operating.

Operation Safety

- Do not permit riders.
- Do not wear loose fitting clothing during operation.
- Do not allow anyone other than the operator close to the auger when in operation.
- Stay clear of snowblower augers.
- Stay clear of snowblower discharge chute. Rocks or debris can be picked up and thrown.
- Never operate equipment in the raised position.

Transport Safety

- Review Transport Safety instructions in tractor manual before moving.
- Check with local authorities regarding transport on public roads. Obey all applicable laws and regulations.
- Make sure the SMV (Slow Moving Vehicle) emblem and all the lights and reflectors that are required by the local highway and transport authorities are in place, are clean, and can be seen clearly by all overtaking and oncoming traffic.
- Never have the equipment in operation during transport.
- Always travel at a safe speed.

Service and Maintenance Safety

- Stop engine, set brake, remove ignition key, and wait for all moving parts to stop before servicing, adjusting, repairing, or unplugging.
- Support the equipment with blocks or safety stands before working beneath it.
- Follow good shop practices including:
 - keep service area clean and dry
 - be sure electrical outlets and tools are properly grounded
 - use adequate light for the job.
- Use only tools, jacks, and hoists of sufficient capacity for the job.
- Replace and secure all shields removed during servicing before operating.
- Use heavy leather gloves to handle sharp objects.
- Check hydraulics regularly for leaks. Use cardboard to look for leaks, and use hand and eye protection.
- Relieve pressure on hydraulic system before repairing or adjusting.

Storage Safety

- Store the unit in an area away from human activity.
- Do not permit children to play on or around the stored machine.
- Support the frame on stands and blocks to provide a secure base.

Safety Signs

- The following illustration shows the approximate location and detail of safety signs.
- Keep all safety signs clean and legible and replace any that are damaged or missing.
- When original parts are replaced, any safety signs affixed to those parts should be replaced as well. Replacement safety signs are available from your local dealer using part number shown in the corner of the sign.

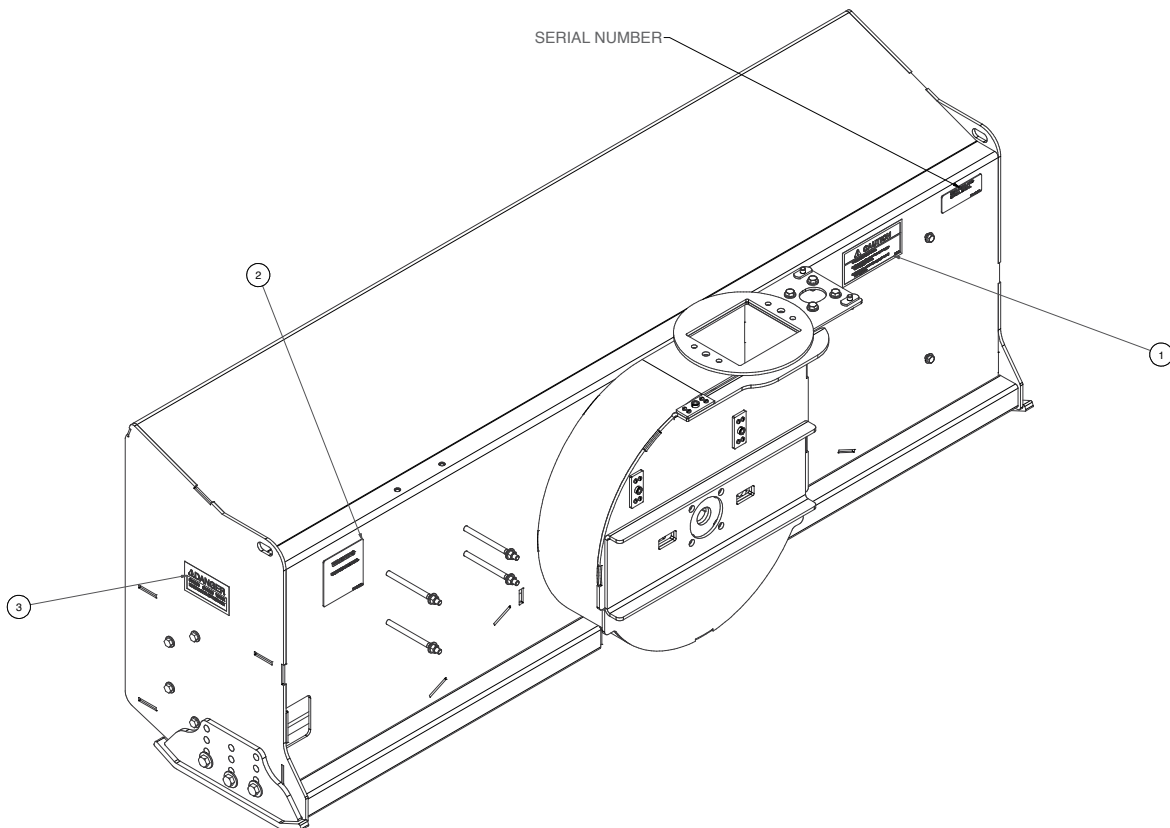

 **CAUTION**

1. Keep all shields in place.
2. Disengage all power when servicing or unplugging machine.
3. Keep hands and clothing away from all moving parts.

963206

1

WARNING

HIGH PRESSURE FLUID HAZARD

P/N: 813635

2

 **DANGER**

STAND CLEAR WHEN
MACHINE IN OPERATION

102893

3

Assembly Instructions

1. Unpack all components and remove from shipping material. Verify quantities provided with parts listing.

NOTE: Depending on your shipping/assembly configuration, steps 2-3 may already be completed.

2. Begin with spout to snowblower assembly:

- Place UHMV spout ring (815503) on top of spout base plate of snowblower fan housing.
- Assemble spout retainer components (815506, 815507, 812364, 84048, 811791, 812363, 81570, 815508, 811795) to left hand set of holes according to the assembly views and tighten all three bolts.

NOTE: Ensure bolts are placed facing upwards so that nuts and washers are on top or damage to the snowblower will result.

NOTE: Avoid over tightening spout hardware. UHMW spout ring will deform/compress from over torqued hardware (see Bolt Torque page) and cause binding in spout rotation.

- Slip spout base into assembled spout retainer and align so that right hand set can be assembled using similar technique. Ensure spout rotates freely once hardware is tightened.
- Remove spout chain shield (815499) and install rotator chain (815496). Rotator motor mounting holes are slotted to allow for installation and tightening of chain once connected. Adjust position of sprocket (815497) on motor shaft so that sprocket is in line with chain tab of spout. Adjust chain tightness and reattach chain shield.

3. Final hydraulic assembly

- Attach deflector cylinder (24930M) to spout in direction shown in photo 10 and install adaptors into ports of cylinder as well as deflector ports of hydraulic manifold. Attach deflector hoses as shown in photo 10, ensuring bottom port of cylinder attached to bottom port of manifold. Install hose retaining hardware and tighten hoses and hardware once suitable routing is established. Spout may need to be rotated part way to the left during hose routing and tightening so that hoses do not become excessively twisted during CCW spout travel.
- Install and tighten remaining two adaptors onto manifold.
- Install and tighten male and female quick couplers to the straight ends of supply hoses and connect elbow ends to adaptors just installed. The top port is system input and male-tipped hose should be connected to this port for most applications. Orientate elbow ends to the right, ensuring hose routings are free from points where damage may occur and tighten.

NOTE: Hoses will be looped rearwards at a later time as shown in photo 2.

4. Universal Wiring Harness Installation (Optional): A three piece universal wiring harness (816225) is provided to allow for quick and easy disconnects and hookups. The snowblower segment is to be left permanently installed to snowblower and has a coupling that can be connected/disconnected conveniently with main hydraulics. The cab harness segment is also easily detachable so the spout control unit can be removed from the skid steer cab when not needed. The main harness segment is designed to stay installed in skid steer while allowing normal use and maintenance of skid steer.

If snowblower is to be operated between two or more skid steer units, extra main harness segments (816220, 816221) can be ordered and installed in each allowing quick change outs between units.

Beginning at the engine compartment of the skid steer, identify a pathway where both branches of the main harness can be safely routed. The snowblower harness branch should usually follow the hydraulic lines running along the lift arm and a coupler should be located next to main hydraulic disconnects. The cab control harness branch should usually follow the routing of the skid steer main electrical harness and enter the cab in a suitable location (usually in same area main harness enters cab). The coupler should be located in a convenient, but out of the way, location somewhere within the cab.

NOTE: Skid steer cab will most likely need to be lifted into maintenance position to perform this routing. Consult appropriate service personnel before proceeding.

When routing harness, keep all portions of harness away from points of wear, excessive heat, and pinching areas. Use cable ties where required to keep harness secured to existing lines, harnesses, or other retaining points. See photos 2 to 9 for a typical routing example. Coil up any excess length of harness and secure in a suitable location in engine compartment (next to battery for example, see photo 7). With battery ground terminal disconnected, connect positive ring terminal of harness (end of fuse) to a switched or unswitched power source. Typical examples may include battery post, auxiliary terminal post (if equipped) or hot terminal of starter solenoid.

NOTE: Contact appropriate service personnel before making such connection.

Connect other ring terminal to a suitable ground location and reconnect battery ground strap. Inside cab, place control box in a convenient location out of the way of other controls and connect other end to coupling previously located inside cab from main harness. Coil up any excess length in an out of the way location after routing harness appropriately.

On snowblower, remove manifold shield and connect snowblower harness segment in arrangement shown in photo 1. Replace shield, making sure that harness exits freely through recess in shield. Harness should then be cable tied to one of the main supply hoses for its entire length. Install hose retainer loop onto one of shield retaining bolt locations using 3/8" x 1-1/4" bolt and 1-1/2" washer. Route supply hoses through it towards skid steer as shown in photo 2. Arrangement may be changed to suit other applications.

NOTE: Spout controls may behave erratically until hydraulic system is primed.

Start-up and Operation Instructions

The hydraulic system of the snowblower is configured so that the fan motor is prevented from stalling in a snow overload condition. A significant increase in fan loading increases the hydraulic pressure drop across the fan motor, which in turn diverts flow away from the auger motor, thereby reducing/stopping further fan loading and simultaneously providing more power to clear the fan. When the fan clears and pressure returns to normal, flow returns to auger so normal operation can proceed. The fan should not require unclogging, other than a situation where a rock or other hard material becomes jammed in it.

Depth of cut at ground level can be controlled both by tilting the snowblower forward/rearward and by using one of the three desired height sets of the skids. If it is preferred that the skids not be used to control cut depth, a fourth set of holes are provided (skid in highest position) but use is not recommended due to the premature cutting edge wear that may result. Snowblower should not be operated with skids completely removed as damage to housing may result.

Each season, the chute rotator chain should be lubricated and checked for excess slack (chain can be tightened by taking advantage of the mounting motor slots). Also, the right hand auger bearing should be greased each season and every 10 hours of use thereafter. Run the snowblower at low RPM to check all operation before blowing snow. Periodically check bolt tightnesses, particularly the fan motor and auger motor housing bolts.

Always disengage hydraulics and shut off the power unit before doing any servicing or unplugging. When replacing bearings or tightening a loose bearing collar, always tighten collar in the direction of shaft rotation using a center punch or a similar tool.

If the fan should need to be removed, use an appropriate two jaw puller using the slots provided in the fan and fan housing backplate. Prior to reassembly, tapered surfaces need to be completely clean (no paint or rust) with a coating of anti-seize compound applied. Castle nut must be torqued to at least 140 ft-lbs and aligned such that the nut can then be retained with new cotter-pin.

If auger motor is removed from auger, its surfaces should also be cleaned and coated with anti-seize compound before re-assembly.



CAUTION

The locking pins must extend through the holes in the attachment when mounting the snowblower to an implement. Levers must be fully down and locked. Failure to secure pins can allow attachment to come off and cause injury or death.

Theory of Operation

Fan Blade Rotation

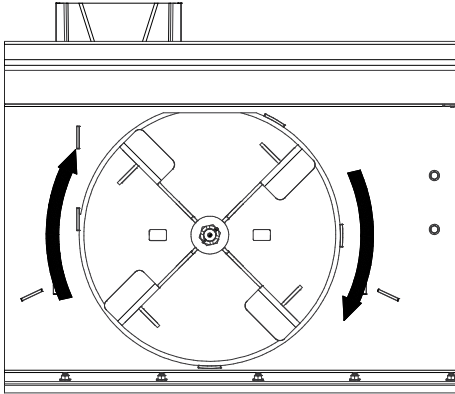

Rotate Spout Left or Right

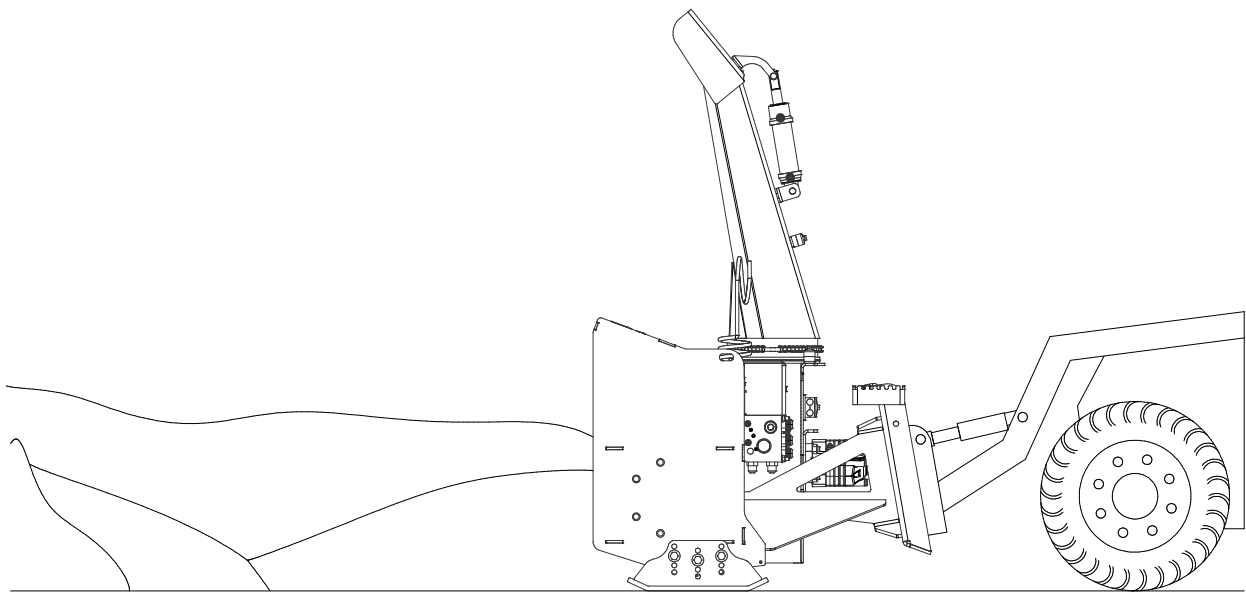
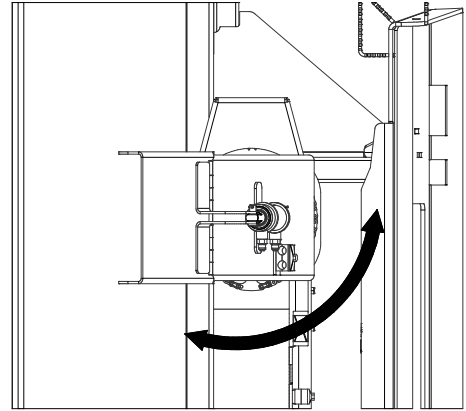

↑
Uncleared Snow

↑
Cleared Snow

Specifications





Model	6025	7225	7235	8425	8435
Width, overall	62" (1575 mm)	74" (1880 mm)	74" (1880 mm)	86" (2184 mm)	86" (2184 mm)
Height, overall	62" (1575 mm)	62" (1575 mm)	67" (1702 mm)	62" (1575 mm)	67" (1702 mm)
Depth	36" (914 mm)	36" (914 mm)	36" (914 mm)	36" (914 mm)	36" (914 mm)
Height, intake	25" (635 mm)	25" (635 mm)	35" (889 mm)	25" (635 mm)	35" (889 mm)
Width, intake	60" (1524 mm)	72" (1829 mm)	72" (1829 mm)	84" (2134 mm)	84" (2134 mm)
Fan Depth, in (mm)	6" (152 mm)	6" (152 mm)	6" (152 mm)	6" (152 mm)	6" (152 mm)
Fan Diameter	20" (508 mm)	20" (508 mm)	24" (607 mm)	20" (508 mm)	24" (607 mm)
Throwing Distance	40' (12.2 m)	40' (12.2 m)	40' (12.2 m)	40' (12.2 m)	40' (12.2 m)
Fan Tip Speed	60 mph (96 kph)	60 mph (96 kph)	71 mph (114 kph)	60 mph (96 kph)	71 mph (114 kph)
Auger Diameter	14" (356 mm)	14" (356 mm)	18" (457 mm)	14" (356 mm)	18" (457 mm)
Auger to Housing Clearance	1" (25 mm)	1" (25 mm)	1" (25 mm)	1" (25 mm)	1" (25 mm)
Flighting Pitch	10" (254 mm)	10" (254 mm)	10" (254 mm)	10" (254 mm)	10" (254 mm)
Chute Rotation Range	270°	270°	270°	270°	270°
Chute Rotation	Hydraulic Motor	Hydraulic Motor	Hydraulic Motor	Hydraulic Motor	Hydraulic Motor
Deflector Control Range	16° below grade to 73° above grade	16° below grade to 73° above grade	16° below grade to 73° above grade	16° below grade to 73° above grade	16° below grade to 73° above grade
Deflector Control	Hydraulic Cylinder	Hydraulic Cylinder	Hydraulic Cylinder	Hydraulic Cylinder	Hydraulic Cylinder
Hydraulic Type	Standard Flow	Standard Flow	High Flow	Standard Flow	High Flow
Hydraulic Flow	20-23 GPM (76 LPM)	20-23 GPM (76 LPM)	20-40 GPM (76 LPM)	20-23 GPM (76 LPM)	20-40 GPM (76 LPM)

Model	6025	7225	7235	8425	8435
Maximum Flow	23 GPM (88 LPM)	23 GPM (88 LPM)	40 GPM (153 LPM)	23 GPM (88 LPM)	40 GPM (153 LPM)
Side Plate Thickness	.25" (6 mm)	.25" (6 mm)	.25" (6 mm)	.25" (6 mm)	.25" (6 mm)
Main Body Thickness	.179" (5 mm)	.179" (5 mm)	.179" (5 mm)	.179" (5 mm)	.179" (5 mm)
Cutting Edge Location	Below center of auger	Below center of auger	Below center of auger	Below center of auger	Below center of auger
Cutting Edge, bolt on	1/2" x 4" (13 x 102 mm)	1/2" x 4" (13 x 102 mm)	1/2" x 4" (13 x 102 mm)	1/2" x 4" (13 x 102 mm)	1/2" x 4" (13 x 102 mm)
Skid Shoes	Adjustable/ Replaceable	Adjustable/ Replaceable	Adjustable/ Replaceable	Adjustable/ Replaceable	Adjustable/ Replaceable
Auger Tube	Square Tubing	Square Tubing	Square Tubing	Square Tubing	Square Tubing
Weight	828 lb (376 kg)	923 lb (419 kg)	1084 lb (491 kg)	951 lb (431 kg)	1108 lb (503 kg)

Bolt Torque

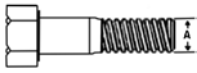
Checking Bolt Torque

The tables shown below give correct torque values for various bolts and hex bolts. Tighten all bolts to the torques specified in chart unless otherwise noted. Check tightness of bolts periodically, using bolt torque chart as a guide. Replace hardware with the same strength bolt.

Bolt Torque*						
						
Bolt Diameter	Grade 2 Bolts		Grade 5 Bolts		Grade 8 Bolts	
(inches)	SAE 2		SAE 5		SAE 8	
"A"	(lb-ft)	(N.m)	(lb-ft)	(N.m)	(lb-ft)	(N.m)
0.25 (1/4)	6	8	9	12	12	17
0.313 (5/16)	10	13	19	25	27	36
0.375 (3/8)	20	27	33	45	45	63
0.438 (7/16)	30	42	53	72	75	100
0.5 (1/2)	45	61	80	110	115	155
0.563 (9/16)	70	95	115	155	165	220
0.625 (5/8)	95	128	160	215	220	305
.75 (3/4)	165	225	290	390	400	540
0.875 (7/8)	170	230	420	570	650	880
1	225	345	630	850	970	1320

Torque figures indicated above are valid for non-greased or non-oiled threads and heads unless otherwise specified. Therefore, do not grease or oil bolts or hex bolts unless otherwise specified in this manual. When using locking elements, increase torque values by 5%.

*Torque value for bolts and hex bolts are identified by their head markings.

Troubleshooting

Symptom	Probable Cause	Remedy
Nothing works	<ul style="list-style-type: none"> Hydraulic valve not engaged One or more quick couplers not completely engaged Incorrect flow direction Defective quick coupler Hydraulic pump low on fluid 	<ul style="list-style-type: none"> Engage to full detent Fully engage all couplers Switch flow direction using controls or swapping hose ends Replace defective quick couplers Top up fluid level
Fan turns too slow	<ul style="list-style-type: none"> Inadequate hydraulic flow for snowblower 	<ul style="list-style-type: none"> Check the gpm of your system, ensure auxilliary pumps is engaged on power unit for high flow models
Fan and auger work but chute controls do not work properly	<ul style="list-style-type: none"> Electrical connections to battery Fuse blown Connector from switches to harness not connecting Air in hydraulic system Insufficient hydraulic power 	<ul style="list-style-type: none"> Ensure that the clamps are making proper connection Replace fuse Ensure the connector is fully engaged. Check for broken wires. Check fluid level of power unit, purge air Check specifications and flow setting
Chute rotation seems to lack power to turn.	<ul style="list-style-type: none"> Broken/disconnected chain Debris/ice caught in chain Chute retainer hardware too tight 	<ul style="list-style-type: none"> Check chain condition Clear chute and chain of obstructions Loosen hardware so that chute can be turned by hand with chain disconnected
Fan stops/slows when raising or turning skid steer	<ul style="list-style-type: none"> Insufficient hydraulic power 	<ul style="list-style-type: none"> Check that operating at full engine RPM Check flow rate and PSI w/ requirements
Skid steer unable to lift snowblower	<ul style="list-style-type: none"> Size mismatch of snowblower vs. skid steer 	<ul style="list-style-type: none"> Match lifting capacity of skid steer with weight of snowblower plus snow load
Chute controls operate backwards	<ul style="list-style-type: none"> Control box mounted in wrong orientation Wiring connected improperly on valve manifold 	<ul style="list-style-type: none"> Mount in appropriate orientation (if not possible, connections may be swapped underneath manifold cover)
One control switch operates two different chute functions	<ul style="list-style-type: none"> Wires connected improperly on valve manifold 	<ul style="list-style-type: none"> Connect wires in proper arrangement

Hydraulic Snowblower - All Models

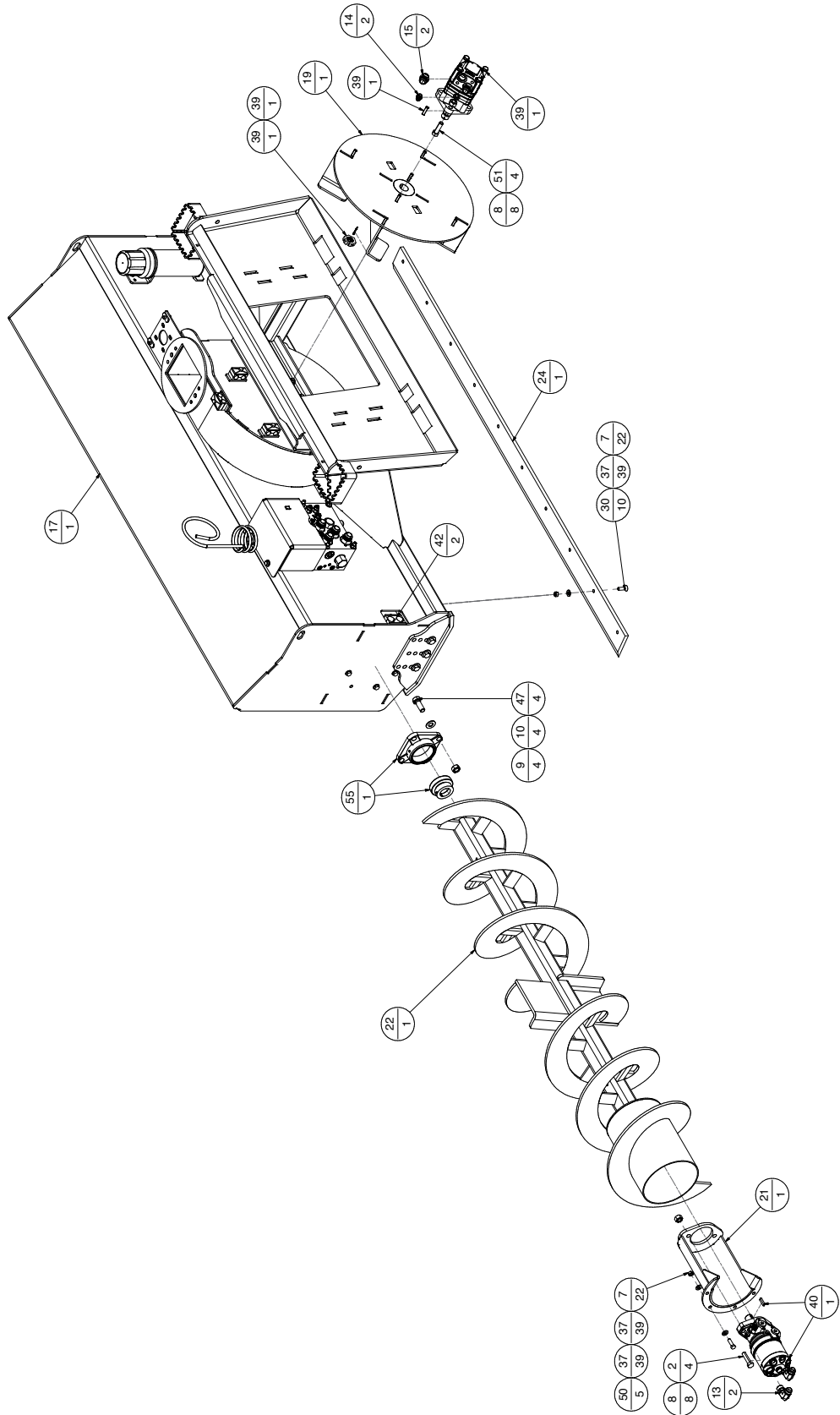

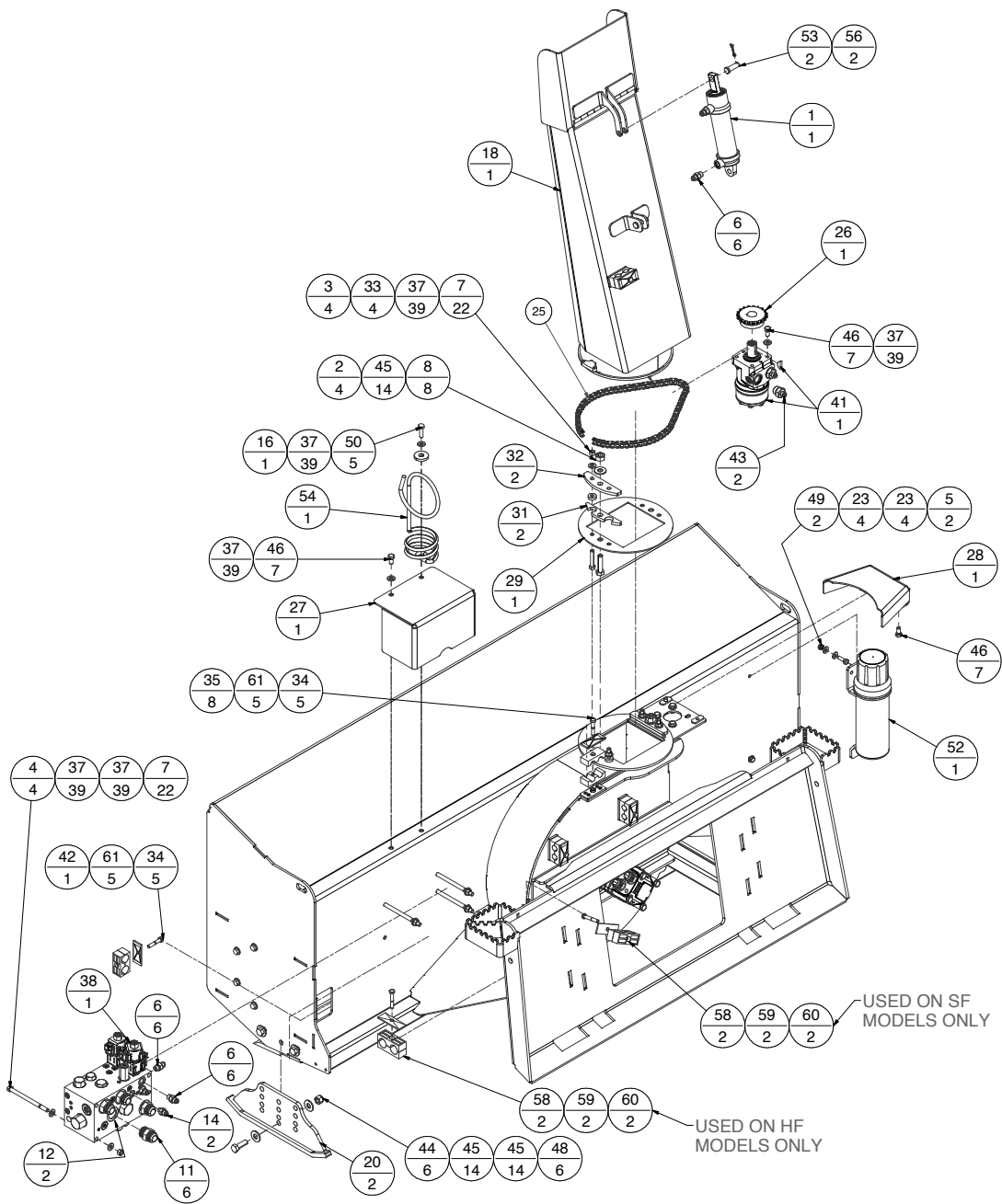

When Ordering Parts

Always give your dealer the Model, Color and Serial Number of your machine to assist them in ordering and obtaining the correct parts. Use the exploded view and tabular listing of the area of interest to exactly identify the required part.

Item	Part Number	Description	Qty
1	24930M	Cyl 1.75 Dia x 5.0 9/16 Orb	1
2	811791	Bolt Hex 0.500Nc x 2.0 Gr5 (PI)	4
3	811795	Bolt Hex 0.375Nc x 2.00 Gr5 (PI)	4
4	812259	Bolt Hex 0.375Nc x 5.50 Gr5 (PI)	4
5	812026	5/16" x 1" Hex Bolt (PI)	2
6	812086	Adaptor Str 9/16 Morb x 9/16 Mjic	6
7	812363	Nut Lock (Steel) 0.375 Grb (PI)	22
8	812364	Nut Lock (Steel) 0.500Nc Grb (PI)	8
9	812482	Nut Lock (Steel) 0.625Nc Grb (PI)	4
10	812639	Washer 0.625 SAE Flat Bs (PI)	4
11	812661	Adaptor Str 1-1/16 Morb x 1-1/6 Mjic	6
12	812723	Adaptor Str 7/8 Mjic x 7/8 Morb	2
13	812734	Elbow 90 7/8 Morb x 7/8 Mjic	2
14	812838	Adaptor Str 7/16 Morb x 9/16 Mjic	2
15	813208	Adaptor Str 1-1/16 Mjic x 7/8 Morb	2
16	813581	Washer Flat 1.5 x 0.531 x 0.25 (PI)	1
17	815538	60" SF Hyd Sb Main Housing Weldt	1
	815438	72" SF Hyd Sb Main Housing Weldt	1
	815963	72" HF Hyd Sb Main Housing Weldt	1
	815942	84" SF Hyd Sb Main Housing Weldt	1
	815953	84" HF Hyd Sb Main Housing Weldt	1
18	815439	Hyd SB Spout Weldt	1
19	815440	Hydraulic SB Fan Weldt - SF Models	1
	815527	Hydraulic SB Fan Weldt - HF Models	1
20	815441	Hyd SB Skid Shoe Weldt	2
21	815444	Hyd SB Auger Motor Mount	1
22	815541	60" Hyd SB Auger Weldt	1
	815445	72" SF Hyd SB Auger Weldt	1
	815530	72" HF Hyd SB Auger Weldt	1
	815946	84" SF Hyd SB Auger Weldt	1
	815957	84" HF Hyd SB Auger Weldt	1
23	81546	Washer 0.313 Flat Std Hs (PI)	4
24	815939	60" Snowblower Cutting Edge	1
	815495	72" Snowblower Cutting Edge	1
	815951	84" Snowblower Cutting Edge	1
25	815496	Hyd SB Spout Chain	1

Item	Part Number	Description	Qty
26	815497	19T 1/2" Pitch Spout Rotation Sprocket	1
27	815498	Hydraulic Manifold - Shield	1
28	815499	Spout Rotation Motor - Shield	1
29	815503	UHMW Spout Ring	1
30	815505	Flat Head Socket Cap 3/8-16 x 1.25	10
31	815506	Snowblower Spout Spacer	2
32	815507	Snowblower Spout Clamp	2
33	815508	Spout Bushing	4
34	81925	Hex Bolt 5/16" x 1-3/4" (PI)	5
35	815608	Block Polypropelene 3/8 Pair	4
37	81570	Washer 0.375 Flat St Hs (PI)	39
38	816041	Hyd SB SF Manifold (Comatrol)	1
	816376	Hyd SB HF Manifold (Comatrol)	1
39	816042	Hydraulic Snowblower - SF Fan Motor	1
	816043	Hydraulic Snowblower - HF Fan Motor	1
40	816044	Hyd SB SF/HF Auger Motor	1
41	816045	Hyd SB SF/HF Spout Motor	1
42	816054	5/8" Block Polypropelene Pair	1
43	816057	Adaptor Str 10 Morb x 6 Mjic	2
44	81966	Nut Lock (Nylon) 0.500Nc (PI)	6
45	84048	Washer 0.500 Flat SAE Bs (PI)	14
46	84072	3/8" x 3/4" Hex Bolt (PI)	7
47	84270	Bolt Hex 0.625 x 1.75 Gr5 (PI)	4
48	84277	Bolt Hex 0.500Nc x 1.50 Gr5 (PI)	6
49	84541	Lock Nut (Nylon) 0.313 Nc	2
50	86171	Bolt Hex 0.375 Nc x 1.25	5
51	87553	Bolt Hex 0.500Nc x 1.75 Gr5 (PI)	4
52	909277	Manual Holder 3.5" Dia.	1
53	961876	1/2" x 1-1/2" Clev Pin (PI)	2
54	966314	Hydraulic Hose Holder	1
55	968632	Housing w/ Brg 4-Bolt Ti F208	1
56	9812430	Cotter Pin 0.125 x 1.00 (PI)	2
57	981309	1/8" x 1-1/4" Cotter Pin (Br)	1
58	816052	3/4 Block Polypropelene Pair	1
59	816051	3/4 Hose Clamp Cover Plate	1
60	810640	Hex Bolt 0.313 Unc x 2.00	1
61	29256	Cover Plate	1

Hose Assembly - Model 60" SF

Part Number	Description
816191	Hose 3/8 x 66 9/16 Fjic x 9/16 F90
816206	Hose 3/4 x 23.8 1-16 Fjic Jic 45
816207	Hose 3/4 x 27.3 1-1/16 Fjic x 45
816208	Hose 5/8 x 25 7/8 Fjic x 7/8 Jic 45
816209	Hose 3/8 x 23-9/16 Fjic x Jic 45
816212	Hose 3/8 x 39 9/16 Fjic 90
816452	Hyd SB Main Return Hose
816189	1/2" Body, Male FF Coupler
816453	Hose 3/4 x 91.3 1-1/16 Morb x Jic
816454	Hyd Main Pressure Hose
816190	1/2" Body, Female FF Coupler
816453	Hose 3/4 x 91.3 1-1/16 Morb x Jic

Hose Assembly - Model 72" SF

Part Number	Description
816191	Hose 3/8 x 66 9/16 Fjic x 9/16 F90
816206	Hose 3/4 x 23.8 1-16 Fjic Jic 45
816207	Hose 3/4 x 27.3 1-1/16 Fjic x 45
816209	Hose 3/8 x 23 9/16 Fjic x Jic 45
816211	Hose 5/8 x 29.5 7/8 Swfjic 45
816212	Hose 3/8 x 39-9/16 Fjic 90
816452	Hyd SB Main Return Hose
816189	1/2" Body, Male FF Coupler
816453	Hose 3/4 x 91.3 1-1/16 Morb x Jic
816454	Hyd Main Pressure Hose
816190	1/2" Body, Female FF Coupler
816453	Hose 3/4 x 91.3 1-1/16 Morb x Jic

Hose Assembly - Model 72" HF

Part Number	Description
816059	Hose 3/8 x 43.4 9/16 Fjic 45
816060	Hose 5/8 x 32 7/8 Fjic x 7/8 Jic 45
816061	Hose 3/8 x 27.7 9/16 Fjic x Jic 45
816191	Hose 3/8 x 66 9/16 Fjic x 9/16 F90
816214	Hyd SB Main Return Hose
816189	1/2" Body, Male FF Coupler
816210	Hose 3/4 x 87 1-1/16 Morb x Jic 45
816215	Hose 3/4 x 30.5 1-1/16 Morb x Jic 45
816216	Hose 3/4 x 31.5 1-1/16 Morb x Jic 45
816219	Hyd Main Pressure Hose
816190	1/2" Body, Female FF Coupler
816210	Hose 3/4 x 87 1-1/16 Morb x Jic 45

Hose Assembly - Model 84" SF

Part Number	Description
816191	Hose 3/8 x 66 9/16 Fjic x 9/16 F90
816206	Hose 3/4 x 23.8 1-16 Fjic Jic 45
816207	Hose 3/4 x 27.3 1-1/16 Fjic x 45
816209	Hose 3/8 x 23 9/16 Fjic x Jic 45
816212	Hose 3/8 x 39 9/16 Fjic 90
816213	Hose 5/8 x 33.5 7/8 Swfjic 45
816452	Hyd SB Main Return Hose
816189	1/2" Body, Male FF Coupler
816453	Hose 3/4 x 91.3 1-1/16 Morb x Jic
816454	Hyd Main Pressure Hose
816190	1/2" Body, Female FF Coupler
816453	Hose 3/4 x 91.3 1-1/16 Morb x Jic

Hose Assembly - Model 84" HF

Part Number	Description
816059	Hose 3/8 x 43.4 9/16 Fjic 45
816061	Hose 3/8 x 27.7 9/16 Fjic x Jic 45
816191	Hose 3/8 x 66 9/16 Fjic x 9/16 F90
816214	Hyd SB Main Return Hose
816189	1/2" Body, Male FF Coupler
816210	Hose 3/4 x 87 1-1/16 Morb x Jic 45
816215	Hose 3/4 x 30.5 1-1/16 Morb x Jic 45
816216	Hose 3/4 x 31.5 1-1/16 Morb x Jic 45
816217	Hose 5/8 x 37 7/8 Swfjic 45
816219	Hyd Main Pressure Hose
816190	1/2" Body, Female FF Coupler
816210	Hose 3/4 x 87 1-1/16 Morb x Jic 45

Manifold

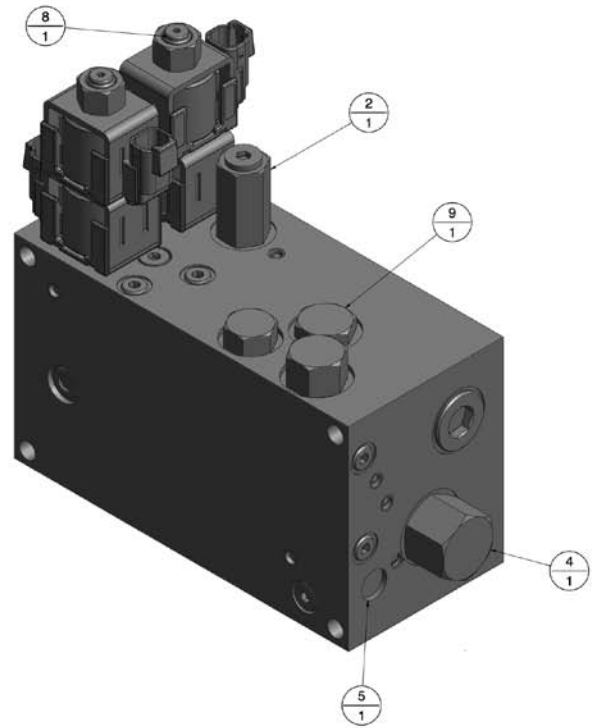
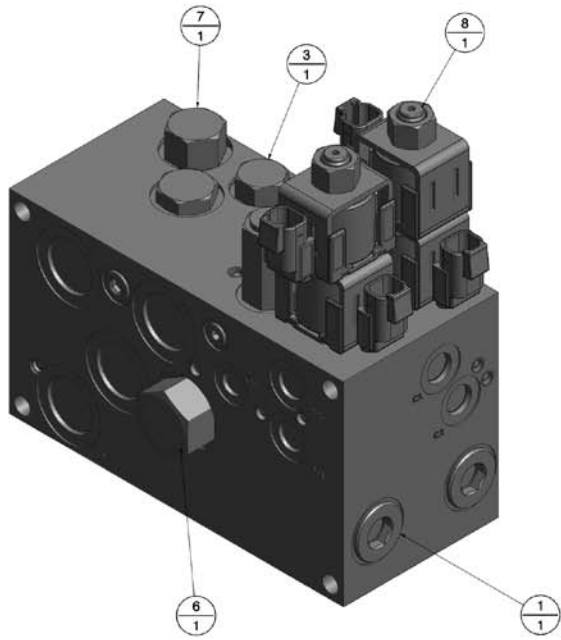

Item	Part Number	Description
1	816420	Plug - Right
	X3929	Seal Kit
2	816421	Relief Valve - High Flow
	816534	Relief Valve - Standard Flow
	X3930	Seal Kit
3	816422	Plug - Top Right
	X3930	Seal Kit
4	816423	Plug - Left Front
	X3932	Seal Kit
5	816424	Plug - Left Rear
	X3933	Seal Kit
6	816425	Plug - Front
	X3932	Seal Kit
7	816426	Plug - Top Left
	X3935	Seal Kit
8	816427	Solenoid
	X3934	Seal Kit
	816428	Coil
	816429	Coil Nut
9	816430	Plug - Top Front
	X3931	Seal Kit

Shipping Kit and Bundle Numbers

Bundle Number Description		Qty
60" Standard Flow - Hydraulic Snowblower (HSB6025SF)		
F1534	Full Assembly w/ Hoses	1
72" Standard Flow - Hydraulic Snowblower (HSB7225SF)		
F1535	Full Assembly w/ Hoses	1
84" Standard Flow - Hydraulic Snowblower (HSB8425SF)		
F1537	Full Assembly w/ Hoses	1
72" High Flow - Hydraulic Snowblower (HSB7235HF)		
F1536	Full Assembly w/ Hoses	1
84" High Flow - Hydraulic Snowblower (HSB8435HF)		
F1538	Full Assembly w/ Hoses	1

Optional Bundle Numbers

The following is a list of options available for the Kits listed above.

Part Number	Description	Qty
X3926	SF Width Extender Kit	1
X3927	HF Width Extender Kit	1
816225	Universal Skid Steer Wiring Harness	1
816464	Bobcat 14 Pin Wire Harness	1
816465	John Deere 14 Pin Wire Harness	1
816466	CAT "B" Series and "C" Series 8 Pin Wire Harness	1
816479	Case "Alpha" Series 14 Pin Wire Harness	1
816513	CAT "B" Series 14 Pin SF Wire Harness	1
816514	CAT "B" Series 14 Pin HF Wire Harness	1

Hole Locations for Width Extendor Kits

HIGH FLOW WIDTH

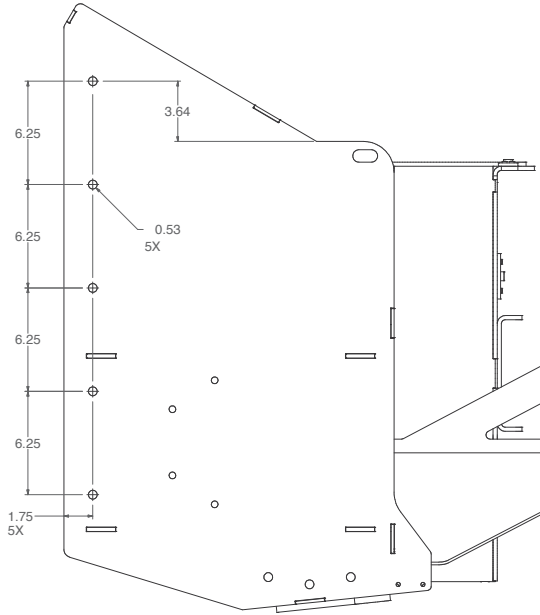

STANDARD FLOW WIDTH

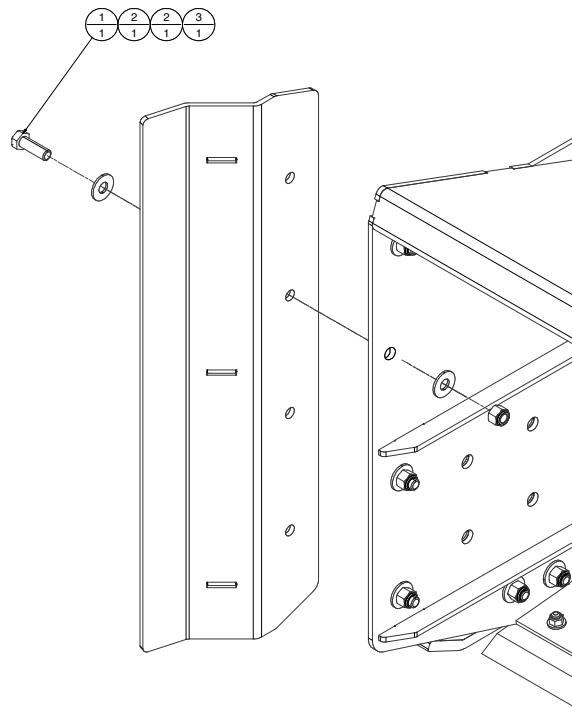
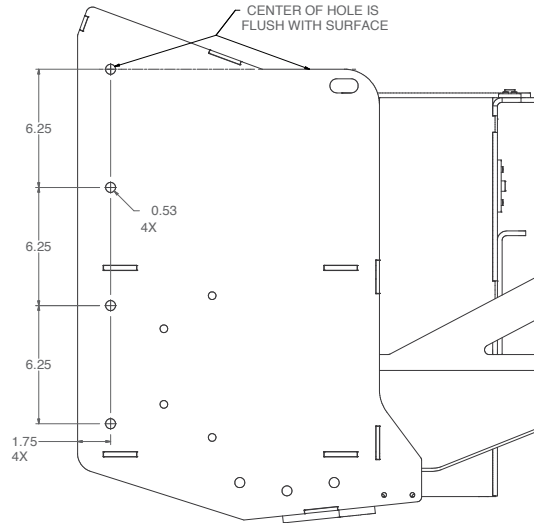

Item	Part Number	Description
1	84277	Bolt Hex 0.500 Nc x 1.50 Gr5 (PI)
2	84048	Washer 0.500 Flat SAE Bs (PI)
3	81966	Nut Lock (Nylon) 0.500 Nc (PI)

Maintenance

Hydraulic Snowblower Wiring Schematic 816225

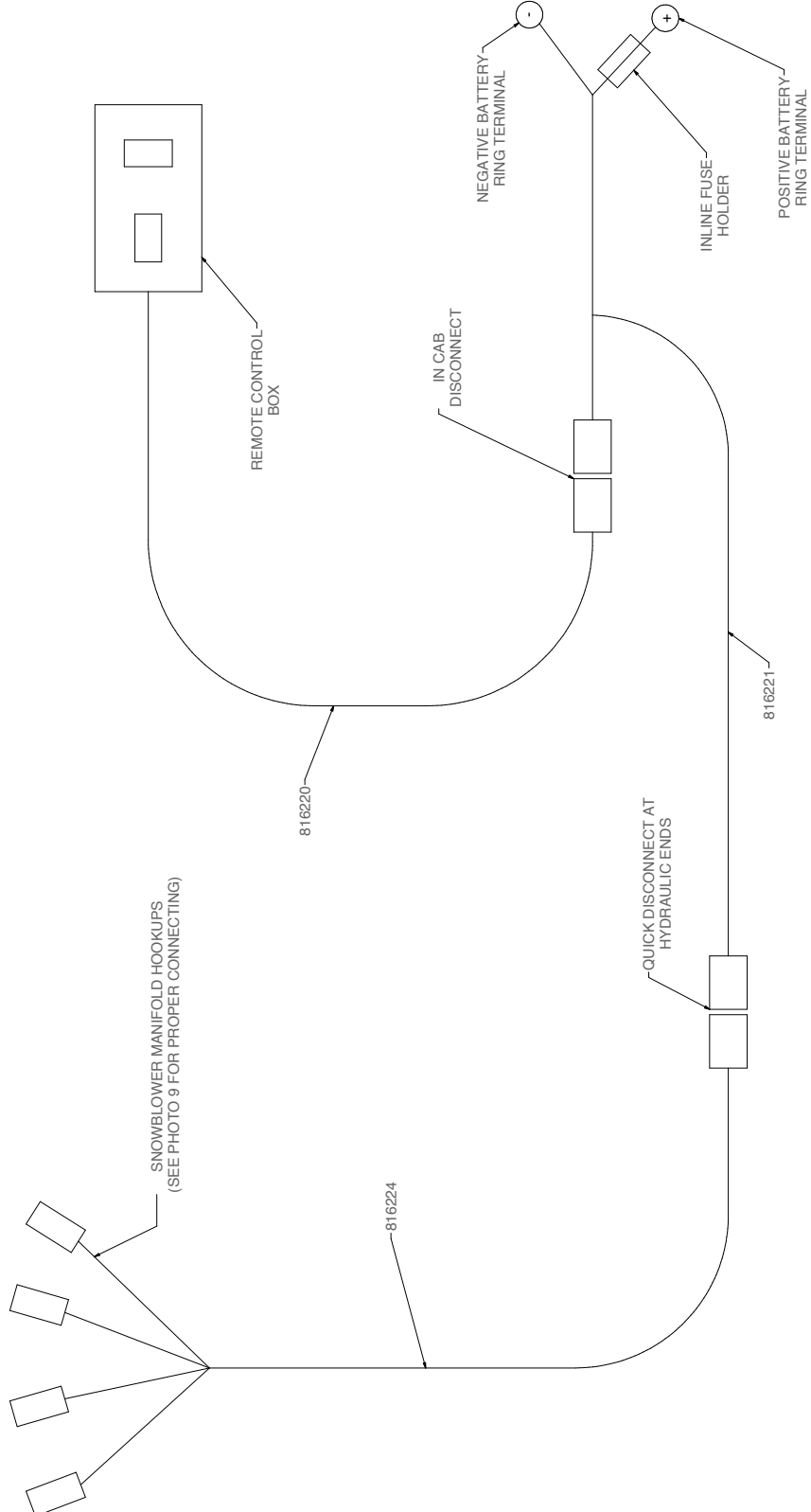

Part Number	Description
816049	Electric Switch Housing - Base
816050	Electric Switch Housing - Top
816220	Hyd SB Harness, Cab
816221	Hyd SB Harness, Battery
816222	Hyd SB Harness, Valve
816223	Eaton Switch - Left & Right
816224	Eaton Switch - Up & Down
816226	3-3/16" Steel Encased Magnet

Pictorial References



Manifold Hookups



Harness secured to hydraulic hose

Top view of snowblower connections

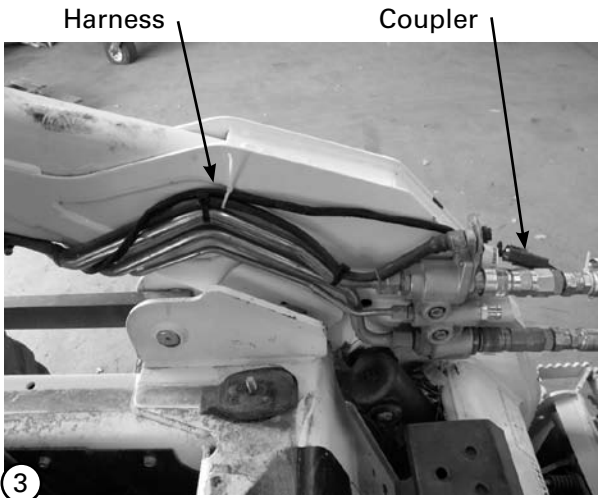

Harness

Coupler

Main harness routing

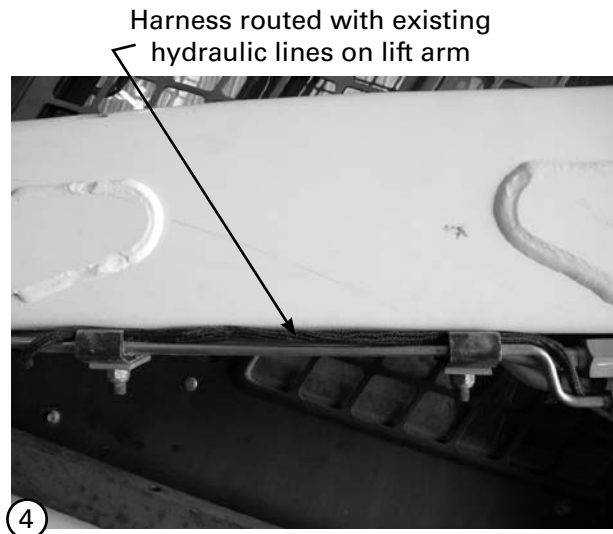

Harness routed with existing hydraulic lines on lift arm

Main harness routing

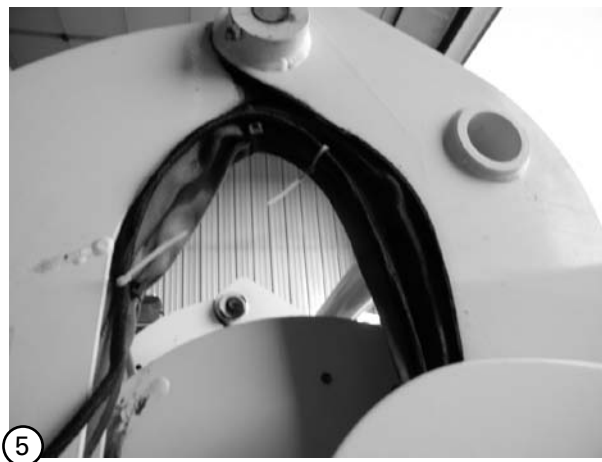

Main harness routing

Main harness routing (cab lifted)



6

Harness follows existing cab harness

Negative Positive Extra length coiled

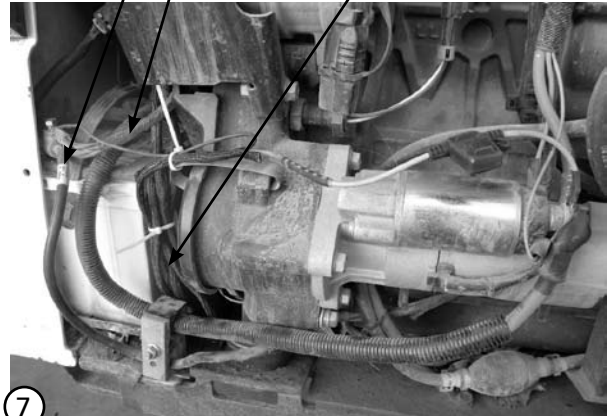

7

Main Harness power connections

Coupler located behind operator station

Coupler from main harness Extra length coiled



8

In-cab harness routing

Control Box



9

In-cab harness routing



10

Chute hydraulic hook-ups

Allied by Farm King Limited Warranty

This document limits your warranty rights.

Base Limited Warranty

Buhler Industries Inc. provides this warranty only to original retail purchasers of its product. Buhler Industries Inc. warrants to such purchasers that all Buhler Industries Inc. manufactured parts and components used and serviced as provided for in the Operator's Manual shall be free from defects in materials and workmanship for a period following delivery to the original retail purchaser of 12 months (80 days for commercial applications). This limited warranty applies only to those parts and components manufactured by Buhler Industries Inc. Parts and components manufactured by others are subject to their manufacturer's warranties, if any.

Buhler Industries Inc. will fulfill this limited warranty by, at its option, repairing or replacing any covered part that is defective or is the result of improper workmanship, provided that the part is returned to Buhler Industries Inc. within thirty (30) days of the date that such defect or improper workmanship is, or should have been, discovered. Buhler Industries Inc. reserves the right to either inspect the product at the buyer's location or have it returned to the factory for inspection. Parts must be returned through the selling representative and the buyer must prepay transportation charges.

Buhler Industries Inc. will not be responsible for repairs or replacements that are necessitated, in whole or part, by the use of parts not manufactured by or obtained from Buhler Industries Inc. Under no circumstances are component parts warranted against normal wear and tear. There is no warranty on product pump seals, product pump bearings, rubber product hoses, pressure gauges, or other components that require replacement as part of normal maintenance. Also: Buckets and Bucket Tines carry no warranty, Bent Spears carry no warranty, Snowblower Fan Shafts carry no warranty, Mower Blades carry no warranty, Portable Auger Parts Have Two (2) Year Warranty, Loader Parts Have Two (2) Year Warranty. The purchaser is solely responsible for determining suitability of goods sold. This warranty is expressly in lieu of all other warranties expressed or implied. Buhler Industries Inc. will in no event be liable for any incidental or consequential damages whatsoever. Nor for any sum in excess of the price received for the goods for which liability is claimed.

Repair Parts Limited Warranty

Buhler Industries Inc. warrants Farm King replacement parts purchased after the expiration of the Buhler Industries Inc. Limited Warranty, and used and serviced as provided for in the Operator's Manual, to be free from defects in materials or workmanship for a period of thirty (30) days from the invoice date for the parts. Buhler Industries Inc. will fulfill this limited warranty by, at its option, repairing or replacing any covered part that is defective or is the result of improper workmanship, provided that the part is returned to Buhler Industries Inc. within thirty (30) days of the date that such defect or improper workmanship is, or should have been, discovered. Such parts must be shipped to Buhler Industries Inc. at the purchaser's expense.

What is Not Covered

Under no circumstances does this limited warranty cover any components or parts that have been subject to the following: negligence; alteration or modification not approved by Buhler Industries Inc.; misuse; improper storage; lack of reasonable and proper maintenance, service, or repair; normal wear; damage from failure to follow operating instructions; accident; and/or repairs that have been made with parts other than those manufactured, supplied, and or authorized by Buhler Industries Inc.

Authorized Dealer and Labor Costs

Repairs eligible for labor under this limited warranty must be made by Buhler Industries Inc. or an authorized Farm King dealer. Buhler Industries Inc. retains the exclusive discretion to determine whether it will pay labor costs for warranty repairs or replacements, and the amount of such costs that it will pay and the time in which the repairs will be made. If Buhler Industries Inc. determines that it will pay labor costs for warranty work, it will do so by issuing a credit to the dealer's or distributor's account. Buhler Industries Inc. will not approve or pay invoices sent for repairs that Buhler Industries Inc. has not previously approved. Warranty service does not extend the original term of this limited warranty.

Warranty Requirements

To be covered by warranty, each Farm King new product must be registered with Buhler Industries Inc. within thirty (30) days of delivery to original retail purchaser. If the customer decides to purchase replacement components before the warranty disposition of such components is determined, Buhler Industries Inc. will bill the customer for such components and then credit the replacement invoice for those components later determined to be covered by this limited warranty. Any such replacement components that are determined not be covered by this limited warranty will be subject to the terms of the invoice and shall be paid for by the purchaser.

Warranty Claims:

Warranty requests must be prepared on Buhler Industries Inc. Warranty Claim Forms with all requested information properly completed. Warranty Claims must be submitted within a thirty (30) day period from date of failure repair.

Warranty Labor:

Any labor subject to warranty must be authorized by Buhler Industries Inc. The labor rate for replacing defective parts, where applicable, will be credited at 100% of the dealer's posted shop rate.

Exclusive Effect of Warranty and Limitation of Liability

TO THE EXTENT PERMITTED BY LAW, BUHLER INDUSTRIES INC. DISCLAIMS ANY WARRANTIES, REPRESENTATIONS, OR PROMISES, EXPRESS OR IMPLIED, AS TO THE QUALITY, PERFORMANCE, OR FREEDOM FROM DEFECT OF THE COMPONENTS AND PARTS COVERED BY THIS WARRANTY AND NOT SPECIFICALLY PROVIDED FOR HEREIN.

TO THE EXTENT PERMITTED BY LAW, BUHLER INDUSTRIES INC. DISCLAIMS ANY IMPLIED WARRANTIES OF MERCHANTABILITY AND FITNESS FOR A PARTICULAR PURPOSE ON ITS PRODUCTS COVERED HEREIN, AND DISCLAIMS ANY RELIANCE BY THE PURCHASER ON BUHLER INDUSTRIES INC.'S SKILL OR JUDGMENT TO SELECT OR FURNISH GOODS FOR ANY PARTICULAR PURPOSE. THE PURCHASER'S ONLY AND EXCLUSIVE REMEDIES IN CONNECTION WITH THE BREACH OR PERFORMANCE OF ANY WARRANTY ON PRODUCTS MANUFACTURED BY BUHLER INDUSTRIES INC. ARE THOSE SET FORTH HEREIN. IN NO EVENT SHALL BUHLER INDUSTRIES INC. BE LIABLE FOR INCIDENTAL OR CONSEQUENTIAL DAMAGES (INCLUDING, BY WAY OF EXAMPLE ONLY AND NOT LIMITATION, LOSS OF CROPS, LOSS OF PROFITS OR REVENUE, OTHER COMMERCIAL LOSSES, INCONVENIENCE, OR COST OF REPLACEMENT OF RENTAL EQUIPMENT). IN NO EVENT SHALL FARM KING'S CONTRACT OR WARRANTY LIABILITY EXCEED THE PURCHASE PRICE OF THE PRODUCT.

(Note that some provinces or states do not allow limitations on how long an implied warranty lasts or the exclusion or limitation of incidental or consequential damages, so the above limitations and exclusion may not apply to you.) This warranty gives you specific legal rights and you may also have other rights, which vary from province to province or state to state.

Buhler Industries Inc. neither assumes nor authorizes any person or entity, including its selling representatives, to assume any other obligations or liability in connections with the sale of covered equipment, or to make any other warranties, representations, or promises, express or implied, as to the quality, performance, or freedom from defect of the components and parts covered herein. No one is authorized to alter, modify, or enlarge this limited warranty, or its exclusions, limitations and reservations.

Corrections of defects and improper workmanship in the manner, and for the applicable time periods, provided for herein shall constitute fulfillment of all responsibilities of Buhler Industries Inc. to the purchaser, and Buhler Industries Inc. shall not be liable in negligence, contract, or on any other basis with respect to the subject equipment.

This limited warranty is subject to any existing conditions of supply which may directly affect Buhler Industries Inc.'s ability to obtain materials or manufacture replacement parts.

Buhler Industries Inc. reserves the right to make improvements in design or changes in specifications to its products at anytime, without incurring any obligation to owners of units previously sold.

Government Legislation:

Warranty terms and conditions are subject to provincial or state legislation.

Important Note: This warranty does not apply to rentals.

www.farm-king.com



1330 43rd Street NW
Fargo, ND USA 58102
Ph.: 701.282.7014 | Fax: 701.282.5865
Toll Free: 888.524.1004
E-mail: info@buhler.com
www.farm-king.com

Equipment shown is subject to change without notice.
©2013 Buhler Trading Inc. Printed in USA. TSX:BUI

bühler | a division of Buhler Industries Inc.