

Rider's Manual

G 450 X



BMW Motorrad



The Ultimate
Riding Machine

Motorcycle data/dealership details

Motorcycle data

Model

Vehicle identification number

Colour code

Date of first registration

Registration number

Dealership details

Person to contact in Service department

Ms/Mr

Phone number

Dealership address/phone number (company stamp)

Details described or illustrated in this booklet may differ from the motorcycle's actual specification as purchased, the accessories fitted or the national-market specification. No claims will be entertained as a result of such discrepancies.

Dimensions, weights, fuel consumption and performance data are quoted to the customary tolerances.

The right to modify designs, equipment and accessories is reserved.

Errors and omissions excepted.

© 2008 BMW Motorrad

Not to be reproduced either wholly or in part without written permission from BMW Motorrad, After Sales.

Printed in Germany.

The most important data for a filling-station stop can be found in the following chart:

Fuel	
Recommended fuel grade	95 ROZ/RON, Super unleaded
Usable fuel capacity	approx. 8 l
Reserve fuel	≥0.75 l
Tyre pressures	
Tyre pressure, front	1.2 bar, one-up, tyre cold
Tyre pressure, rear	1.2 bar, one-up, tyre cold
Tyre pressure for sport riding	1.0 bar

BMW recommends 

Order No.: 01 41 7 714 581
09.2008, 2nd edition

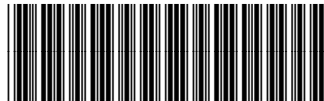

Welcome to BMW

We congratulate you on your choice of a motorcycle from BMW and welcome you to the community of BMW riders.

Familiarise yourself with your new motorcycle so that you can ride it safely and confidently in all traffic situations.

Please read this Rider's Manual carefully before starting to use your new BMW motorcycle. It contains important information on how to operate the controls and how to make the best possible use of all your BMW's technical features.

In addition, it contains information on maintenance and care to help you maintain your motorcycle's reliability and safety, as well as its value.

If you have questions concerning your motorcycle, your authorised

BMW Motorrad dealer will gladly provide advice and assistance.

We hope that you will enjoy riding your BMW and that all your journeys will be pleasant and safe.

BMW Motorrad.

Table of Contents

You can also consult the index at the end of this Rider's Manual if you want to find a particular topic or item of information.

1 General instructions 5

Overview	6
Abbreviations and symbols	6
Definition of use	7
Technical data	8
Currency	8

2 General views 9

General view, left side	11
General view, right side	13
Handlebar fitting, left	14
Handlebar fitting, right	15
Instrument panel	16

3 Status indicators 17

Status indicators	18
Warnings	18

4 Operation..... 21

Ignition and steering lock....	22
Instrument panel	23
Lights	31
Turn indicators	32
Mirrors	32
Handlebars	33
Spring preload	36
Damping	39
Headlight	41
Seat	42

5 Riding..... 45

Engine revs	46
Safety instructions	46
Checklist	48
Starting engine	48
Running in	49
Riding off-road	50
Increasing engine power	50
Possible ratios.....	51
Brakes	52
Park your motorcycle.....	53
Refuelling	54

Securing motorcycle for transportation	56
--	----

6 Accessories 59

General instructions	60
----------------------------	----

7 Maintenance 61

General instructions	62
Regular maintenance	62
Maintenance for off-road- ing	63
Toolkit.....	64
Engine oil	65
Brake system	66
Brake pads	67
Brake fluid.....	69
Coolant.....	71
Clutch.....	72
Tyres.....	72
Rims	73
Chain.....	73
Telescopic forks.....	74
Spring strut	75
Bulbs.....	75
Fuses	79

Battery	81	Riding specifications	98
Instrument panel	82	10 Service	99
8 Care	85	BMW Motorrad service....	100
Care products	86	BMW Motorrad service	
Washing motorcycle.....	86	quality	100
Cleaning easily damaged		BMW Motorrad Service	
components.....	86	Card: on-the-spot break-	
Laying up motorcycle	87	down assistance	100
Restoring motorcycle to		BMW Motorrad service	
use	87	network	101
9 Technical data	89	Maintenance work.....	101
Threaded fasteners	90	Confirmation of mainten-	
Engine	91	ance work	102
Fuel	92	Confirmation of service....	107
Engine oil	92		
Clutch	93		
Transmission	93		
Rear-wheel drive	94		
Running gear	94		
Brakes	95		
Wheels and tyres.....	95		
Electrics	96		
Frame	97		
Dimensions	97		
Weights	98		

General instructions

Overview	6
Abbreviations and symbols	6
Definition of use	7
Technical data	8
Currency.....	8

Overview

Chapter 2 of this Rider's Manual will provide you with an initial overview of your motorcycle. All maintenance and servicing work on the motorcycle is documented in Chapter 10. This record of the maintenance work you have had performed on your motorcycle is a precondition for generous treatment of goodwill claims.

When the time comes to sell your BMW, please remember to hand over this Rider's Manual; it is an important part of the motorcycle.

Abbreviations and symbols



Indicates warnings that you must comply with for reasons of your safety and the safety of others, and to protect your motorcycle against damage.



Specific instructions on how to operate, control, adjust or look after items of equipment on the motorcycle.



Indicates the end of an item of information.



Instruction.



Result of an activity.



Reference to a page with more detailed information.



Indicates the end of a passage relating to specific accessories or items of equipment.



Tightening torque.



Item of technical data.

OA

Optional accessory
You can obtain optional accessories through your authorised BMW Motorrad dealer; optional accessories have to be retrofitted to the motorcycle.

AS

Alternative standard equipment
Component supplied with the motorcycle and usable instead of an installed component. Always comply with the applicable instructions for installation.

Definition of use

This motorcycle is designed to withstand the normal stresses and strains of off-road riding.

However, it is not suitable for use under the following conditions:

- Prolonged periods of riding at steady high speed
- Riding at constant full throttle
- Trips with passenger and/or luggage
- Riding for extended periods with engine revving at speeds in excess of 8000 rpm

Technical data

All dimensions, weights and power ratings stated in the Rider's Manual are quoted to the standards and comply with the tolerance requirements of the Deutsche Institut für Normung e.V. (DIN). Versions for individual countries may differ.

Currency

The high safety and quality standards of BMW motorcycles are maintained by constant development work on designs, equipment and accessories. Because of this, your motorcycle may differ from the information supplied in the Rider's Manual. Nor can BMW Motorrad entirely rule out errors and omissions. We hope you will appreciate that no claims can be entertained on the basis of the data, illustrations or descriptions in this manual.

General views

General view, left side.....	11
General view, right side	13
Handlebar fitting, left.....	14
Handlebar fitting, right	15
Instrument panel.....	16



General view, left side

- 1** Adjuster for headlight beam throw (underneath the instrument panel) (→ 42)
- 2** Adjuster for damping characteristic, front suspension (rebound stage) (→ 39)
- 3** Secondary fuses (→ 79)
- 4** Main fuse (behind side panel) (→ 80)
- 5** Fuel filler neck (→ 54)
- 6** Adjuster for damping characteristic, front suspension (compression stage) (→ 39)
- 7** Battery



General view, right side

- 1** Adjuster for damping characteristic, rear suspension (compression stage) (➡ 39)
- 2** Brake-fluid reservoir, front (➡ 69)
- 3** Coolant filler neck (behind side panel) (➡ 71)
- 4** Engine-oil filler neck (➡ 66)
- 5** Engine oil level indicator (➡ 65)
- 6** Brake-fluid reservoir, rear (➡ 70)
- 7** Adjuster for damping characteristic, rear suspension (rebound stage) (➡ 39)

Handlebar fitting, left

- 1 Operation of the headlight flasher (→ 31)
- 2 Horn
- 3 Operation of the flashing turn indicators (→ 32)
- 4 High-beam headlight switch (→ 31)

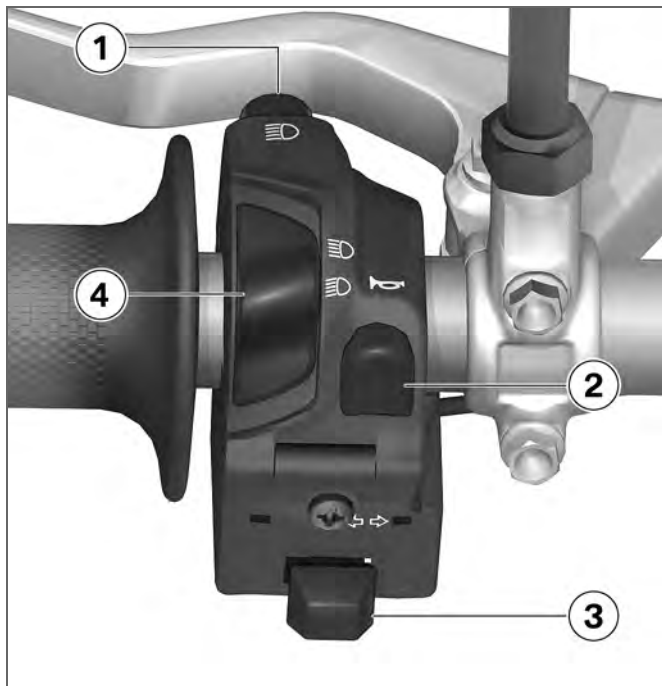

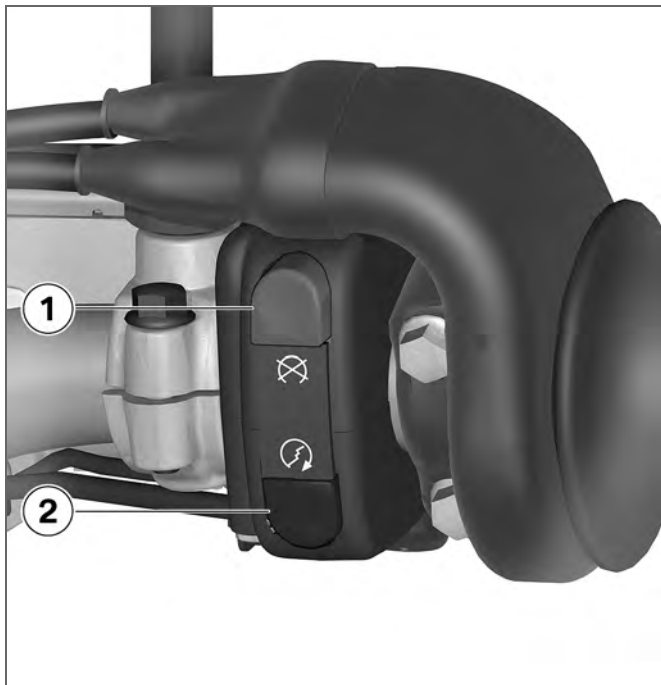

Handlebar fitting, right

- 1 Engine OFF button
(➡ 48)
- 2 Starter button (➡ 48)

Instrument panel

- 1 Operating the multifunction display (➔ 23)
- 2 Telltale lights (➔ 18)
- 3 Multifunction display (➔ 18)

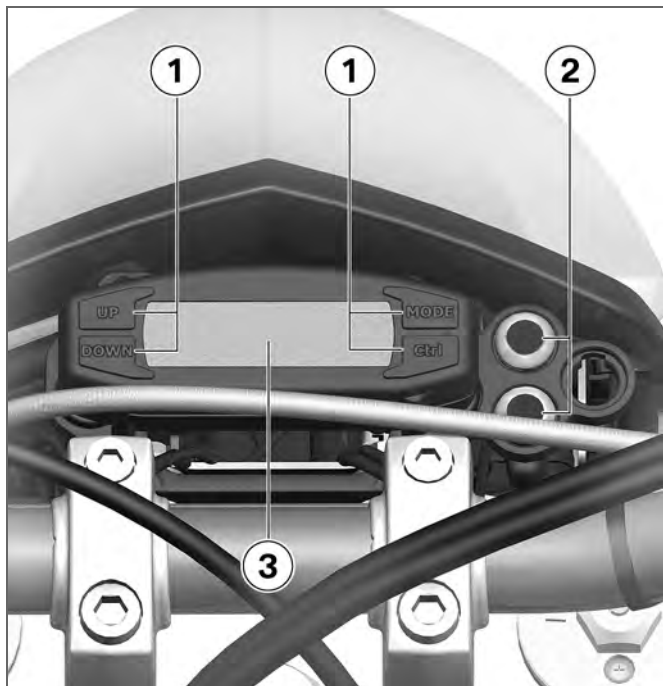

Status indicators

Status indicators	18
Warnings	18

Status indicators

Multifunction display



- 1 Display depends on the mode selected; this view shows the odometer reading (➔ 23)
- 2 Speedometer

Telltale lights

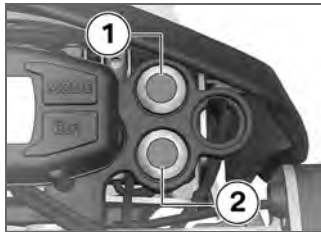

- 1 High-beam headlight
- 2 Turn indicators

Warnings

Fuel down to reserve



– FUEL appears on the display.



The fuel-pump symbol appears on the display.



Lack of fuel can result in the engine misfiring and cutting out unexpectedly. Misfiring can damage the catalytic converter; a hazardous situation can result if the engine cuts out unexpectedly.

Do not run the fuel tank dry.◀

Possible cause:

The fuel tank contains no more than the reserve quantity of fuel.

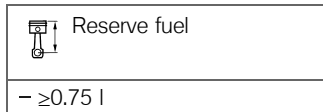

- Refuelling (➡ 54).

Engine rpm too high



- SPEED MAX appears on the display.
- The display flashes.



Prolonged riding with the engine revving at speeds in excess of 8000 rpm can lead to engine damage.

Avoid revving the engine to speeds in excess of 8000 rpm.◀

The motorcycle is not designed for extended periods of revving at engine speeds in excess of 8000 rpm. The registered speed indicates that the engine was revved above the critical rpm threshold.

Possible cause:

Speed in excess of 110 km/h maintained for excessive period of time.

- Reduce speed to below 110 km/h.
- Read the in-depth explanations on durability and warranty on (➡ 46).

Operation

Ignition and steering lock	22
Instrument panel	23
Lights	31
Turn indicators	32
Mirrors	32
Handlebars	33
Spring preload	36
Damping	39
Headlight	41
Seat	42

Ignition and steering lock

Keys

This motorcycle does not have an ignition switch. You receive two keys for the steering lock.

Switching on ignition



- Push full-beam switch **1** up and then operate headlight-flasher button **2**.

 The instrument panel is activated automatically as soon as the motorcycle moves away from rest. ◀

- » High-beam headlight and all function circuits switched on.
- Push full-beam headlight switch **1** down.
- » High-beam headlight switched off.



- Alternatively: Briefly press starter button **2**.
- » Low-beam headlight and all function circuits switched on.
- » The engine will start if the starter button is not released after being pressed only briefly.

Switch off the ignition

The ignition switches off automatically shortly after the motor-cycle is brought to a standstill.

Locking handlebars

- Turn the handlebars all the way to the left



- Pivot cover **1** aside.
- Use key **2** to turn the steering lock clockwise, while moving the handlebars slightly.
- » Handlebars locked.
- Remove the key and pivot the cover into position over the lock.

Instrument panel

Activating instrument panel



- Press MODE button **1**.

▶ The instrument panel is activated automatically as soon as the motorcycle moves away from rest. ◀

- » All the segments of the display light up briefly.
- » The tyre-size setting shows briefly.
- » The instrument panel is ON.

» The instrument panel switches itself off shortly after the ignition has been switched off.

Function selection

In the motorcycle's as-delivered condition only the operating hours counter (H) and the odometer (ODO) are active.

The following functions can be activated in addition:

- Trip recorder TR1
- Trip recorder TR2: Reading can be altered manually, for example to match a roadbook
- Stopwatch S1: Always active when the motorcycle is on the move
- Stopwatch S2: Operated manually
- Average speed A1: Calculated from TR1 and S1
- Average speed A2: Calculated from TR2 and S2
- Clock CLK
- Lap-timer LAP

– Top speed MAX

Activating and deactivating functions

- Bring the motorcycle to a standstill.



- Repeatedly press MODE button **1** until operating-hours counter H appears in the left half of the multifunction display.
- Press and hold down the MODE button.
- » The instrument panel switches to set mode and all active functions are displayed.

- » The first selectable function (trip recorder TR1) starts flashing.
- » The operating hours counter H and the odometer ODO cannot be deactivated.



- Press MODE button **1**.
- » No change is made to the function and the next selectable function starts flashing.
- Press UP button **2**.
- » The function is activated and the next selectable function starts flashing.
- Press DOWN button **3**.

- » The function is deactivated and the next selectable function starts flashing.
- » Once the desired functions have been selected you can choose between miles per hour (mph) and kilometres per hour (km/h).

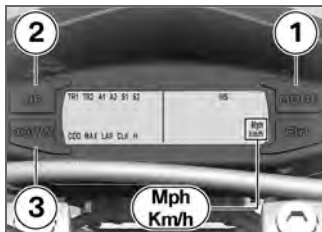

- Press UP button **2**.
- » The kilometres per hour (km/h) display mode is activated.
- Press DOWN button **3**.
- » The miles per hour (mph) display mode is activated.
- Press MODE button **1** twice.

▶ The tyre size is set before the motorcycle leaves the factory and should not be changed.◀

- » The tyre size can be set within the first operating hour.
- Press MODE button **1** twice.
- » The first selectable function (trip recorder TR1) starts flashing again.
- Either press and hold down MODE button **1** or wait without pressing any button.
- » The current settings are accepted.

Selecting readings



- Press MODE button **1**.

Each time the button is pressed, starting at the current reading the display steps through the activated functions in the following sequence:

- Trip recorder TR1
- Trip recorder TR2
- Average speed A1
- Average speed A2
- Stopwatch S1
- Stopwatch S2
- Operating-hours counter H
- Clock CLK

- Lap timer LAP
- Lap-time memory (only when LAP timer is activated)
- Top speed MAX
- Odometer ODO

Resetting trip recorder TR1



- Repeatedly press MODE button **1** until trip recorder TR1 appears in the left half of the multifunction display.
- Press and hold down the MODE button.
- » Trip recorder TR1 is reset.

- » Average speed A1 and stopwatch S1 are also reset.

Operating trip recorder TR2



- Repeatedly press MODE button **1** until trip recorder TR2 appears in the left half of the multifunction display.



- Press UP button **2**.
 - » The reading of the trip recorder increases.
- Press DOWN button **3**.
 - » The reading of the trip recorder decreases.
- Pressing UP or DOWN button changes the speed at which the trip-recorder reading changes.
 - » A change in the reading of trip recorder TR2 causes average speed A2 to change accordingly.
- Press and hold down MODE button **1**.

- » The trip recorder is reset.
- » Average speed A2 is also reset.

Resetting average speed A1



- Repeatedly press MODE button **1** until average speed A1 appears in the left half of the multifunction display.
- Press and hold down the MODE button.
 - » Average speed is reset to zero.
 - » Trip recorder TR1 and stopwatch S1 are also reset.

Resetting average speed A2

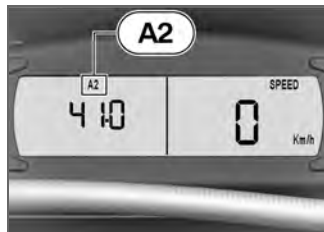

Average speed A2 is reset automatically when stopwatch S2 or trip recorder TR2 is reset.

Resetting stopwatch S1



- Repeatedly press MODE button **1** until stopwatch S1 appears in the left half of the multifunction display.
- Press and hold down the MODE button.
 - » The stopwatch is reset to zero.
 - » Trip recorder TR1 and average speed A1 are also reset.

Operating stopwatch S2



- Repeatedly press MODE button **1** until stopwatch S2 appears in the left half of the multifunction display.



- Press UP button **2** while the stopwatch is not running.
 - » The stopwatch begins timing in seconds from the time originally shown.
 - » S2 flashes on the display if some other function is selected while the stopwatch is running.
 - » The stopwatch runs on even if the instrument panel switches itself off.
- Press the UP button while the stopwatch is running.
 - » The stopwatch shows the stopped time.

- Press and hold down MODE button **1** when the stopwatch is not running.
 - » The stopwatch is reset to zero.
 - » Average speed A2 is also reset.

Operating-hours counter H



The operating hours H counted represent the time logged by the motorcycle in operation. The operating-hours counter cannot be reset and can be viewed only when the motorcycle is at a standstill.

Setting clock CLK

- Switch on the instrument panel or bring the motorcycle to a stop, as applicable.



- Repeatedly press MODE button **1** until clock CLK appears in the left half of the multifunction display.



- Press and hold down MODE button **1**.
 - » The hours reading flashes.
- Use UP button **2** and DOWN button **3** to set the hour.
 - Press the MODE button.
 - » The minutes reading flashes.
- Use the UP button and the DOWN button to set the minutes.
 - Press the MODE button.
 - » The seconds reading flashes.
- Press the UP button or the DOWN button.
 - » The seconds are set to zero.



- Press MODE button **1**.
 - » 0-24 for 24-hour clock or 0-12 for 12-hour clock.
- Press UP button **2** or DOWN button **3**.
 - » The display mode toggles each time a button is pressed.
- Either press and hold down the MODE button or wait without pressing any button.
 - » The settings are accepted.

Operating lap timer LAP



- Repeatedly press MODE button **1** until lap timer LAP appears in the left half of the multifunction display.



- With the LAP timer stopped, press UP button **2**.
 - » The LAP timer counts in seconds, starting at the time shown on the display.
 - » LAP flashes on the display if some other function is selected while the lap timer is running.
 - » The lap timer runs on even if the instrument panel switches itself off.
- With the lap timer running, press the UP button.
 - » The lap timer shows the time elapsed.

- With the LAP timer running, press DOWN button **3**.
 - » The reading is saved, timing starts again at zero.
 - » A maximum of ten readings can be saved. Once the ten slots in memory are full, there is no reaction when the DOWN button is pressed.
- With the LAP timer stopped, press and hold down MODE button **1**.
 - » The lap timer is reset.
 - » The readings saved beforehand are deleted.

Viewing lap times saved in memory

- Bring the motorcycle to a standstill.



- Repeatedly press MODE button **1** until LAP appears in the left half of the multifunction display.
 - » The left side of the multifunction display shows the time registered by the stopwatch for the lap shown on the right.



- Press UP button **2**.
 - » The next lap time appears on the display.

Selecting display colour

- Switch on the ignition and the instrument panel or bring the motorcycle to a standstill, as applicable.



- Press and hold down Ctrl button **4**.
- » The display colour can be varied in shades of red and yellow.
- Press UP button **2**.
- » This increases the proportion of red in the colour of the display.
- Press DOWN button **3**.
- » This increases the proportion of yellow in the colour of the display.
- Either press and hold down Ctrl button **4** or wait without pressing any button.

- » The setting for the display colour is accepted.

Lights

Position lights and low-beam headlight

The position lights and the low-beam headlight are switched on automatically with the ignition.

High-beam headlight



- Push full-beam headlight switch **1** up.
- » High-beam headlight switched on.

- Push full-beam headlight switch **1** down.
- » High-beam headlight switched off.

Headlight flasher



- Press button **1**.
- » The high-beam headlight is switched on until you release the button (headlight flasher).

Turn indicators

Operating flashing turn indicators



- Push turn-indicator button **1** to the left.
 - » Left-hand turn indicators switched on.
 - » The turn indicator telltale light flashes.
- Push the turn-indicator button to the right.
 - » Right-hand turn indicators switched on.
 - » The turn indicator telltale light flashes.

- Centre the turn-indicator switch.
 - » Flashing turn indicators switched off.
 - » The turn indicator telltale light goes out.

Mirrors

Adjusting mirrors



- Turn the mirror to the correct position.

Adjusting mirror arm



- Slacken nut **1**.
- Turn the mirror arm to the appropriate position.
- Tighten the nut to the specified tightening torque, while holding the mirror arm to ensure that it does not move out of position.



Mirror to handlebar

– 20 Nm

Handlebars

Adjusting handlebar reach

 If not correctly installed, the handlebar clamping blocks can work loose from the fork bridge.

Install the handlebar clamping blocks only in the positions described below. ◀

- Make sure the ground is level and firm and place the motorcycle on its stand.

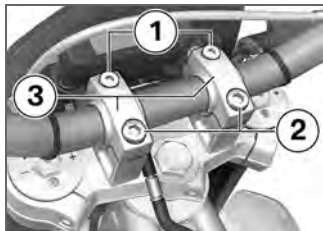

- Remove small screws **1**.

- While holding the handlebars, remove large screws **2**.
- Remove top clamping blocks **3**.
- Lift the handlebars clear of the bottom clamping blocks.

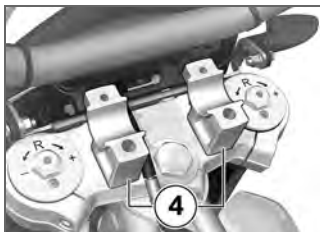

- Remove bottom handlebar clamping blocks **4**.



- Position of the bottom handlebar clamping blocks for minimum reach.



- Position of the bottom handlebar clamping blocks for medium reach.

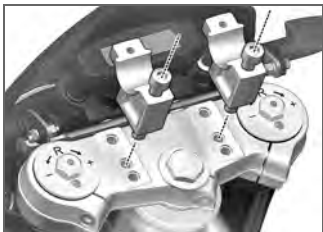

- Position of the bottom handlebar clamping blocks for maximum reach.

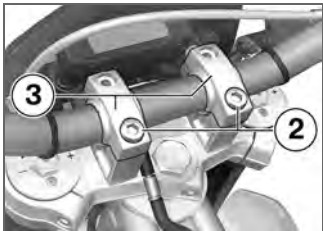

- Position the handlebars and top handlebar clamping blocks **3** on the bottom

handlebar clamping blocks, and hold the handlebars in position.

- Install large screws **2**, but do not tighten.

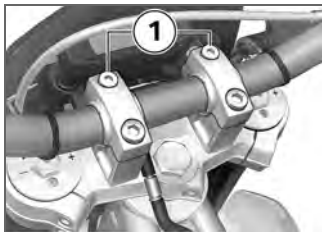

- Install small screws **1**, but do not tighten.
- Adjust the handlebar tilt (→ 35).

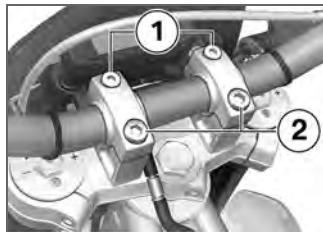

- Tighten large screws **2** to the specified tightening torque.



Handlebar clamping block with handlebars to fork bridge

– 38 Nm

- » Make sure that there is no gap between the handlebar clamping blocks on the side where the large screws are located.
- If necessary, slacken small screws **1** and retighten large screws **2** to the specified tightening torque.

- Tighten small screws **1** to the specified tightening torque.



Handlebar clamping block

– 19 Nm

- » A gap remains between the handlebar clamping blocks on the side where the small screws are located.

Adjusting handlebar tilt

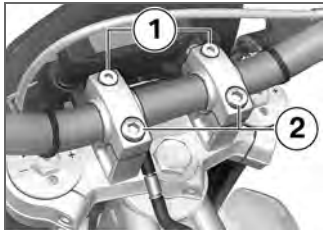

- Slacken small screws **1**.
- Slacken large screws **2**.

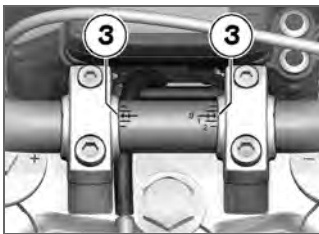

- Align the mark for the appropriate angle of tilt with notches **3**.



- Tighten large screws **2** to the specified tightening torque.



Handlebar clamping block with handlebars to fork bridge

– 38 Nm

- » Make sure that there is no gap between the handlebar clamping blocks on the side where the large screws are located.
- If necessary, slacken screws **1** and retighten screws **2** to the specified tightening torque.
- Tighten small screws **1** to the specified tightening torque.



Handlebar clamping block

– 19 Nm

- » A gap remains between the handlebar clamping blocks on the side where the small screws are located.

Spring preload

Adjustment for rear suspension

Rear spring preload must be adjusted to suit the weight of the rider. The factory setting is intended for a rider's weight of 85 kg. Minor deviations from this standard weight can be compensated for by adjusting spring preload; if the deviation is more significant a different spring has to be installed.

Adjusting static sag

- Remove all load from the motorcycle's rear suspension, so that the rear wheel is clear of the ground (e.g. with the aid of an auxiliary stand).

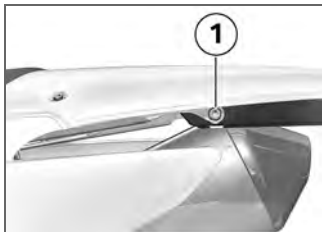

- In order to ensure that the reference point for measurement is correct, always centre the measuring tape over screw **1** and read off the distance at the centre of the screw head.

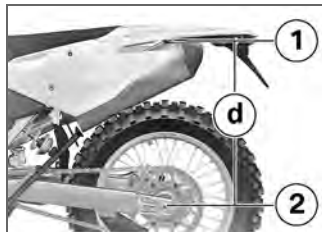

- Measure distance **d** between screw **1** in the tail section and top of axle tube **2**.
- Remove the auxiliary stand and, with the assistance of another person, hold the motorcycle upright.
- Measure distance **d** between points **1** and **2** again and calculate the difference between the two measured values.



Static sag of the spring strut

– Negative spring displacement of rear wheel

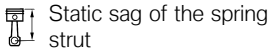

Static sag of the spring strut

– 35...40 mm (with fuel and lubricants, unladen)

If the calculated value is outside the specified range:

- Adjust spring preload until static sag is inside the specified range.
- Adjust the spring preload for rear wheel (➡ 38).

Checking weighted sag

- Adjust the static sag (➡ 36).
- Make a note of the measured distance for the rear wheel with no weight applied to the suspension.

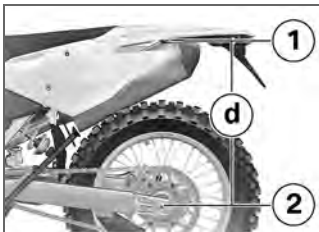

- With the assistance of another person, hold the motorcycle with rider, wearing full protective gear, mounted on the motorcycle and seated in the normal riding position. Rock the suspension up and down a few times.
- With the assistance of another person, measure distance **d** between points **1** and **2**. Calculate the difference between this value and the value noted beforehand for the distance with no weight on the rear wheel.



Load-dependent adjustment of spring preload

– Negative spring displacement of rear wheel

– 105...110 mm (Full load of fuel, with rider 85 kg)

If the calculated value is slightly outside the specified range:

- Adjust spring preload until weighted sag is inside the specified range.
- Adjust the spring preload for rear wheel (➡ 38).

If the calculated value is well outside the specified range:

- A spring matched to the weight of the rider has to be installed. Consult a specialist workshop, preferably an authorised Öhlins dealer (www.ohlins.com).

Adjusting spring preload for rear wheel

- Make sure the ground is level and firm and place the motorcycle on its stand.

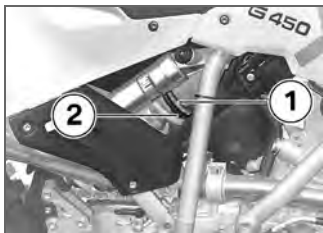

- Use adjusting rings **1** and **2** to adjust spring preload.

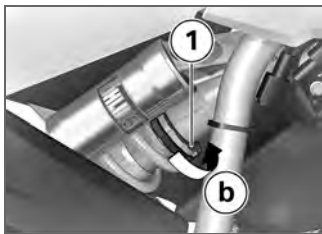

- Release the lock by turning adjusting ring **1** in direction **b** with the tool from the toolkit.

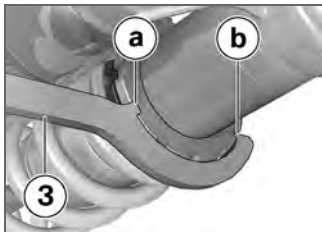

- To turn the adjusting rings, engage tools **3** in such a way that

hook **a** or hook **b** securely engages a groove.

▷ The adjusting rings can be turned in either direction without turning the tool over: simply engage the appropriate hook in a groove.◀

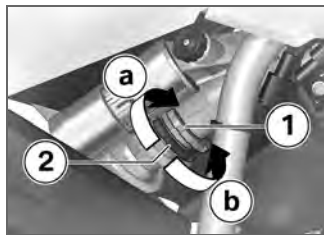

- If you want to increase spring preload, turn adjusting ring **2** in direction **a**.
- If you want to reduce spring preload, turn adjusting ring **2** in direction **b**.
- Tighten the lock by turning adjusting ring **1** in direction **a** with the tool from the toolkit.

 Locknut for spring basic setting at top spring retainer

– 5 Nm

- Adjust the damping characteristic to suit spring preload.

Damping Setting

Damping must be adapted to suit the surface on which the motorcycle is ridden and to suit spring preload.

- An uneven surface requires softer damping than a smooth surface.
- An increase in spring preload requires firmer damping, a reduction in spring preload requires softer damping.

Adjusting front rebound stage

- Make sure the ground is level and firm and place the motorcycle on its stand.



- Use adjusting screws **1** on left and right to adjust the rebound stage. Make sure that the settings are identical on left and right.

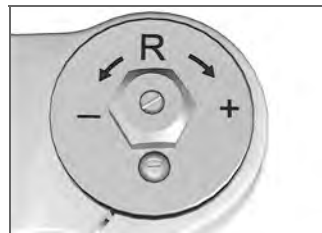

- If you want to increase damping, use a screwdriver to turn the adjusting screws on left and right in the + direction.
- If you want to reduce damping, use a screwdriver to turn the adjusting screws on left and right in the - direction.

 Rebound stage, basic setting, front

- Turn top adjusting screw as far as it will go in the "+" direction, then back it off 12 clicks in the "-" direction.

Adjusting front compression stage

- Make sure the ground is level and firm and place the motor-cycle on its stand.

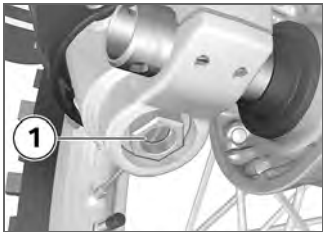

- Adjust the compression stage by turning adjusting screws **1** at the underside of the front forks, left and right. Make sure that the settings are identical.
- If you want to increase damping, use a screwdriver to turn the adjusting screws on left and right in the clockwise direction.

- If you want to reduce damping, use a screwdriver to turn the adjusting screws on left and right in the counter-clockwise direction.



Compression stage, basic setting, front

- Turn bottom adjusting screw as far as it will go in the clockwise direction, then back it off 10 clicks in the counter-clockwise direction.

Adjusting rear rebound stage

- Make sure the ground is level and firm and place the motor-cycle on its stand.



- Adjust the rebound stage by turning adjusting ring **1**.

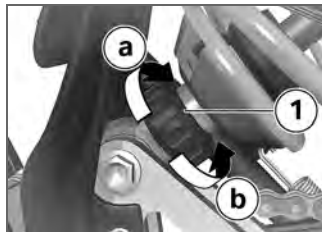

- If you want to reduce the rebound stage, turn adjusting ring **1** in direction **a**.

- If you want to increase the rebound stage, turn adjusting ring **1** in direction **b**.

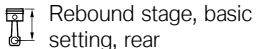

Rebound stage, basic setting, rear

- Turn bottom knob clockwise to limit stop, then back it off 20 clicks. (Full load of fuel, with rider 85 kg)



- Adjust the compression stage by turning adjusting ring **1**.

- If you want to reduce the compression stage, turn adjusting ring **1** in the S direction.

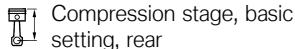

Compression stage, basic setting, rear

- Turn top knob clockwise to limit stop, then back it off 12 clicks. (Full load of fuel, with rider 85 kg)

Adjusting rear compression stage

- Make sure the ground is level and firm and place the motorcycle on its stand.

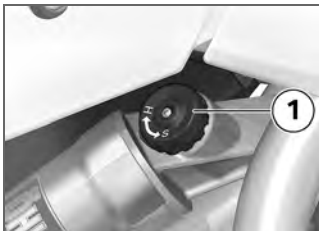

- If you want to increase the compression stage, turn adjusting ring **1** in the H direction.

Headlight

Headlight beam throw and spring preload

Headlight beam throw is generally kept constant when spring preload is adjusted to suit load. Spring preload adjustment might not suffice only if the motorcycle is very heavily loaded. Under these circumstances, headlight beam throw has to be adjusted to suit the weight carried by the motorcycle.

▶ Consult a specialist workshop, preferably an authorised BMW Motorrad dealer, if you are unsure whether the headlight basic setting is correct. ◀

Headlight beam-throw adjustment



- 1** Headlight beam-throw adjustment

Spring preload adjustment might not suffice if the motorcycle is very heavily loaded. Moving the adjuster adjusts headlight beam

throw so as not to dazzle oncoming traffic.

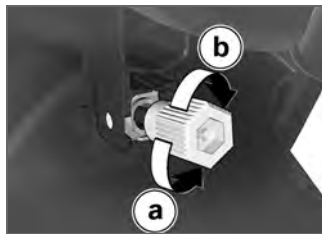

- a** Increasing beam throw
b Reducing beam throw

Seat

Removing seat

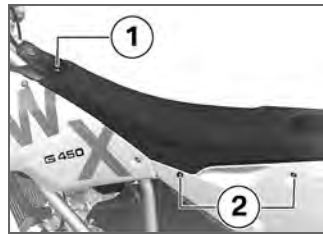

- Remove screw **1**.
- Remove screws **2** on left and right.



- Work the seat to the rear to remove, by raising centre trim panel **3** at the rear and working the seat clear at position **4**.

Installing seat



- Lift centre trim panel **3** at the rear and work the seat into position at **4**.

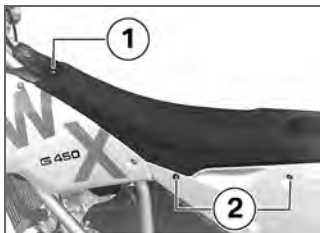

- Install screws **2** on left and right.

- Install screw **1** while pressing down on the centre trim panel.

Riding

Engine revs	46
Safety instructions	46
Checklist	48
Starting engine	48
Running in	49
Riding off-road	50
Increasing engine power	50
Possible ratios	51
Brakes	52
Park your motorcycle	53
Refuelling	54
Securing motorcycle for transportation	56

Engine revs



Prolonged riding with the engine revving at speeds in excess of 8000 rpm can lead to engine damage.

Avoid revving the engine to speeds in excess of 8000 rpm. ◀

Your motorcycle is not designed for extended periods of revving at engine speeds in excess of 8000 rpm. Riding with the engine revving at speeds in excess of 8000 rpm can result in damage and engine-revolution excursions above this limit are logged in the control unit's memory.

BMW Motorrad refuses to accept liability for engine damage if engine-revolution excursions above this limit are stored in the control unit's memory.

The instrument panel displays a warning as a visual indicator of critical engine speed if the motorcycle is ridden at a speed in

excess of 110 km/h for an extended period of time.

Gear-to-speed table for 8000 rpm and standard final-drive transmission ratio:

- 1st gear: 40 km/h
- 2nd gear: 60 km/h
- 3rd gear: 85 km/h
- 4th gear: 105 km/h
- 5th gear: 125 km/h

Safety instructions

Rider's equipment

Do not ride without the correct clothing. Always wear:

- Helmet
- Motorcycling jacket and trousers
- Gloves
- Boots

This applies even to short journeys, and to every season of the year. Your authorised BMW Motorrad dealer will be glad to

advise you on the correct clothing for every purpose.

Speed

If you ride at high speed, always bear in mind that various boundary conditions can adversely affect the handling of your motorcycle:

- Settings of the spring-strut and shock-absorber system
- Imbalanced load
- Loose clothing
- Insufficient tyre pressure
- Poor tyre tread
- Etc.

Maximum speeds for tyres



The motorcycle's top speed might be higher than the maximum speed permitted for the tyres. Excessive speeds can damage the tyres and this could cause accidents.

Comply with the tyre-specific speed restrictions. ◀

Correct loading

 Overloading and imbalanced loads can adversely affect the motorcycle's handling. Do not exceed the permissible gross weight and be sure to comply with the instructions on loading.◀

Alcohol and drugs

 Even small amounts of alcohol or drugs will adversely affect your perception and your ability to assess situations and make decisions, and slow down your reflexes. Medication can exacerbate these effects.

Do not ride your motorcycle after consuming alcohol, drugs and/or medication.◀

Risk of poisoning

Exhaust fumes contain carbon monoxide, which is colourless and odourless but highly toxic.

 Inhaling the exhaust fumes therefore represents a health hazard and can even cause loss of consciousness with fatal consequences.

Do not inhale exhaust fumes.

Do not run the engine in an enclosed space.◀

High voltage

 Touching live parts of the ignition system with the engine running can cause electric shock.

Do not touch parts of the ignition system when the engine is running.◀

Catalytic converter

If misfiring causes unburned fuel to enter the catalytic converter, there is a danger of overheating and damage.

For this reason, observe the following points:

- Do not run the fuel tank dry.
- Stop the engine immediately if it misfires.
- Use only unleaded fuel.
- Comply with all specified maintenance intervals.

 Unburned fuel will destroy the catalytic converter. Note the points listed for protection of the catalytic converter.◀

Risk of fire

Temperatures at the exhaust are high.

 Flammable materials (e.g. hay, leaves, grass, clothing and luggage, etc.) could ignite

if allowed to come into contact with the hot exhaust pipe.

Do not permit flammable materials to come into contact with the hot exhaust system. ◀

⚠ Cooling would be inadequate if the engine were allowed to idle for a lengthy period with the motorcycle at a standstill: overheating would result. In extreme cases, the motorcycle could catch fire. Do not allow the engine to idle unnecessarily. Ride away immediately after starting the engine. ◀

Tampering to increase engine power

Tampering with the motorcycle in such a way as to tune it for increased engine power can render the motorcycle non-compliant with the regulations governing its use on public roads and void insurance cover. Claims for con-

sequential damage will not be accepted.

⚠ Tampering with the motorcycle in such a way as to tune it for increased engine power can cause damage to the motorcycle and lead to accidents involving injury to persons. Do not tamper with the motorcycle in any way that could result in tuned performance. ◀

Checklist

Use the following checklist to check important functions, settings and wear limits before you ride off.

- Brakes
- Brake-fluid levels, front and rear
- Clutch
- Clutch-lever play
- Damping-characteristic setting and spring preload

- Tyre-tread depth and tyre pressures

At regular intervals:

- Engine oil level (every operating hour)
- Brake-pad wear (every third refuelling stop)

Starting engine

- Retract and secure the side stand.
- Select neutral or, if a gear is engaged, pull the clutch lever.



- Press starter button **2**.

▶ If ambient temperatures are very low, you might find it necessary to open the throttle slightly when starting the engine. At ambient temperatures below 0 °C, disengage the clutch after switching on the ignition.◀

» The engine starts.



• Press engine OFF button 1.

» The engine switches off.

Running in

The first five hours

- While running in the motor-cycle, vary the throttle opening and engine-speed range frequently.
- Avoid maintaining constant engine speeds over lengthy periods and accelerating to the rpm limit.

	Maximum speeds during running-in period
---	---

– ≤110 km/h (in 5th gear)

- Have the first inspection performed after two operating hours.

Brake pads

New brake pads have to bed down before they can achieve their optimum friction levels. You can compensate for this initial reduction in braking efficiency by

exerting greater pressure on the levers.



New brake pads can extend stopping distance by a significant margin.

Apply the brakes in good time.◀

Tyres

New tyres have a smooth surface. This must be roughened by riding in a restrained manner at various heel angles until the tyres are run in. This running in procedure is essential if the tyres are to achieve maximum grip.



Tyres do not have their full grip when new and there is a risk of accidents at extreme angles of heel.

Avoid extreme angles of heel.◀

Riding off-road

Tyre pressure

! Tyre pressures reduced for off-road riding impair the motorcycle's handling characteristics on surfaced roads and can lead to accidents.

Always check that the tyre pressures are correct. ◀

Wheel rims for riding off-road

BMW Motorrad recommends checking the rims for damage after off-riding.

Dirt or mud on brakes

! When riding on loose surfaces or muddy roads, the brakes may fail to take effect immediately because of dirt or moisture on the discs or brake pads.

Apply the brakes in good time

until the brakes have been cleaned. ◀

! The brake pads will wear more rapidly if you ride frequently on unsurfaced tracks or poor roads.

Check the thickness of the brake pads more frequently and replace the brake pads in good time. ◀

Spring preload and shock-absorber settings

! The off-road settings for spring preload and shock absorber damping characteristic will impair the motorcycle's handling characteristics on surfaced roads.

If you have been off-riding, remember to correct spring preload and shock-absorber damping characteristics before you return to surfaced roads. ◀

Increasing engine power

– with coded plug^{AS}



- Remove screws **1** and remove the right side panel.

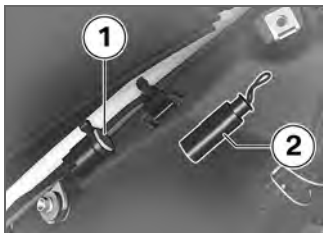

- Remove the cable tie from cap **1**.

! With its built-in coded plug, the motorcycle is no longer approved for use on public roads. Do not ride on public roads with built-in coded plugs.◀

- Activate increased engine power by installing coded plug **2** instead of cap **1**.



Engine power rating

– 30 kW (without coded plug)

– 38 kW (with coded plug)

- Before riding the motorcycle on public roads, remove the coded plug and install the cap.
- Secure the plug with cable ties.



- Hold the right side panel in position and install screws **1**.

Possible ratios

The motorcycle comes complete with a second pinion that can be used to change the final-drive gear ratio. Your authorised BMW Motorrad dealer stocks other pinions as spare parts. Always bear in mind that the length of the chain might have to be altered,

depending on the transmission ratio selected.



With the final-drive transmission ratio altered the motorcycle is no longer compliant with the regulations governing use on public roads.

Do not attempt to ride the motorcycle on public roads with any final-drive transmission ratio other than the ex-works ratio.◀

The procedure for replacing the pinion is described in the Repair Manual on RepROM.

Before taking the motorcycle onto a public road, always check that the final-drive transmission ratio corresponds to the ex-works condition (see the section entitled "Technical Data").

Brakes

How can stopping distance be minimised?

Each time the brakes are applied, a load distribution shift takes place with the load shifting forward from the rear to the front wheel. The sharper the motorcycle decelerates, the more load is shifted to the front wheel. The higher the wheel load, the more braking force can be transmitted without the wheel locking.

To optimise stopping distance, apply the front brakes rapidly and keep on increasing the force you apply to the brake lever. This makes the best possible use of the dynamic increase in load at the front wheel. Remember to pull the clutch at the same time. In the "panic braking situations" that are trained so frequently braking force is applied as rapidly as possible and with the

rider's full force applied to the brake levers; under these circumstances the dynamic shift in load distribution cannot keep pace with the increase in deceleration and the tyres cannot transmit the full braking force to the surface of the road. Under these circumstances the front wheel can lock up.

Descending mountain passes

 There is a danger of the brakes fading if you use only the rear brakes when descending mountain passes. Under extreme conditions, the brakes could overheat and suffer severe damage.

Use both front and rear brakes, and make use of the engine's braking effect as well.◀

Wet brakes

 After the motorcycle has been washed, ridden through water or ridden in the rain, the brake discs and pads might be wet and the brakes might not take effect immediately.

Apply the brakes in good time until the brakes have dried out.◀

Salt on brakes

 The brakes may fail to take effect immediately if the motorcycle was ridden on salt-covered roads and the brakes were not applied for some time. Apply the brakes in good time until the salt layer on the brake discs and brake pads has been removed.◀

Oil or grease on brakes

! Oil and grease on the brake discs and pads considerably diminish braking efficiency.

Especially after repair and maintenance work, make sure that the brake discs and brake pads are free of oil and grease.◀

Dirt or mud on brakes

! When riding on loose surfaces or muddy roads, the brakes may fail to take effect immediately because of dirt or moisture on the discs or brake pads.

Apply the brakes in good time until the brakes have been cleaned.◀

! The brake pads will wear more rapidly if you ride frequently on unsurfaced tracks or poor roads.

Check the thickness of the brake

pads more frequently and replace the brake pads in good time.◀

Park your motorcycle Placing motorcycle on side stand

! If the ground is soft or uneven, there is no guarantee that the motorcycle will rest firmly on the stand.

Always check that the ground under the stand is level and firm.◀

- Switch off the engine.
- Pull the handbrake lever.
- Dismount to the left.

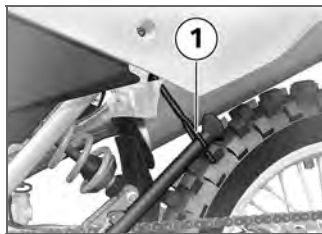

- Hold the motorcycle upright with your left hand and use your right hand to release rubber retainer **1**.

! If the side stand is not kept in the extended position until it is supporting the weight of the motorcycle it will automatically retract and the motorcycle will topple.

Keep the side stand firmly in the fully extended position until the motorcycle is resting securely on it.◀

- Use your right foot to extend the side stand to the limit of its

travel and keep it in this position.



The side stand is designed to support only the weight of the motorcycle.

Do not lean or sit on the motorcycle with the side stand extended.◀

- Slowly lean the motorcycle onto its side stand.



If the motorcycle is on the side stand, the surface of the ground will determine whether it is better to turn the handlebars to the left or right. However, the motorcycle is more stable on a level surface with the handlebars turned to the left than with the handlebars turned to the right.

On level ground, always turn the handlebars to the left to set the steering lock.◀

- Turn the handlebars to full left or right lock.
- Check that the motorcycle is standing firmly.



On a gradient, the motorcycle should always face uphill; select 1st gear.◀

- Lock the steering lock.

Removing motorcycle from side stand

- Unlock the steering lock.
- Lift the motorcycle to the upright position.
- » The side stand retracts automatically.



- Secure the side stand in the retracted position with rubber retainer **1**.
- Take a firm grip of the handlebars with both hands.
- Pull the handbrake lever.
- Swing your right leg over the motorcycle and lower your weight onto the seat.

Refuelling





Fuel is highly flammable. A naked flame close to the fuel tank can cause a fire or explosion.

Do not smoke. Never bring a naked flame near the fuel tank.◀

 Fuel expands when hot. Fuel escaping from an overfilled tank could make its way onto the rear tyre. This could cause a fall.

Do not fill the tank past the bottom edge of the filler neck.◀

 Fuel attacks plastics, which become dull or unsightly. Wipe off plastic parts immediately if they come into contact with fuel.◀

 Leaded fuel will destroy the catalytic converter. Use only unleaded fuel.◀

• Make sure the ground is level and firm and place the motorcycle on its stand.

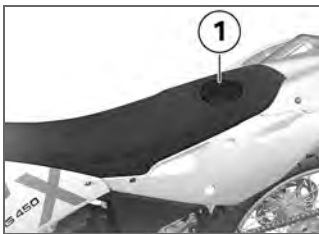

- Remove fuel-cap cover **1**.

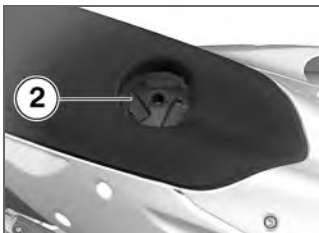

- Turn fuel cap **2** counter-clockwise to open.
- Refuel with fuel of the grade stated below.

 Recommended fuel grade

– 95 ROZ/RON (Super unleaded)

 Usable fuel capacity

– approx. 8 l

 Reserve fuel

– ≥ 0.75 l

- Turn the cap of the fuel tank clockwise to close.

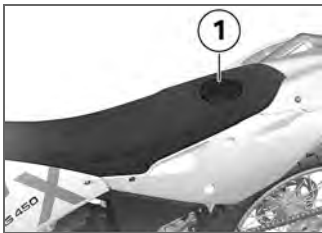

- Install fuel-cap cover **1**.

Securing motorcycle for transportation

- Make sure that all components that might come into contact with straps used to secure the motorcycle are adequately protected against scratching. Use adhesive tape or soft cloths, for example, for this purpose.



! The motorcycle can topple and fall on its side.

Make sure that the motorcycle cannot topple sideways.◀

- Push the motorcycle onto the transportation flat and hold it in position: do not place it on the side stand or centre stand.



! Risk of damaging components.

Take care not to trap components such as brake lines or wires.◀

- At the front, secure the straps to the bottom fork bridge on both sides and tighten the straps.

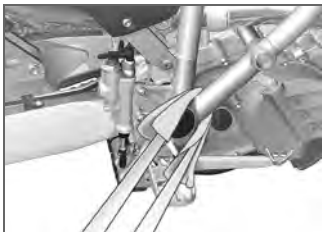

- At the rear, secure the straps to the frame on both sides and tighten the straps.
- Tighten all the straps uniformly; the motorcycle's suspension should be compressed as tightly as possible front and rear.

Accessories

General instructions..... 60

General instructions

BMW Motorrad recommends the use of parts and accessories for your motorcycle that are approved by BMW for this purpose. Genuine BMW parts and accessories and other products which BMW has approved can be obtained from your authorised BMW Motorrad dealer, together with expert advice on their installation and use.

These parts and products have been tested by BMW for safety, function and suitability. BMW accepts product liability for them. Conversely, BMW is unable to accept any liability whatsoever for parts and accessories which it has not approved.



BMW Motorrad cannot assess each non-BMW product to determine whether it can be used on or in connection with BMW motorcycles

without constituting a safety hazard. Country-specific official authorisation does not suffice as assurance. Tests conducted by these instances cannot make provision for all operating conditions experienced by BMW motorcycles and, consequently, they are not sufficient in some circumstances.

Use only parts and accessories approved by BMW for your motorcycle. ◀

Whenever you are planning modifications, comply with all the legal requirements. Make sure that the motorcycle does not infringe national road-vehicle construction and use regulations.

Maintenance

General instructions.....	62	Bulbs	75
Regular maintenance	62	Fuses	79
Maintenance for off-roading	63	Battery.....	81
Toolkit	64	Instrument panel.....	82
Engine oil	65		
Brake system	66		
Brake pads	67		
Brake fluid	69		
Coolant	71		
Clutch	72		
Tyres	72		
Rims	73		
Chain	73		
Telescopic forks	74		
Spring strut	75		

General instructions

The Maintenance chapter describes straightforward procedures for checking and replacing certain wear parts.

Special tightening torques are listed as applicable. The tightening torques for the threaded fasteners on your motorcycle are listed in the section entitled "Technical data".

Below you will find an overview of all the maintenance tasks that have to be carried out as soon as the motorcycle has logged certain operating hours. The overview also includes descriptions of the tasks that have to be carried out before and after each off-road ride.

You will find information on more extensive maintenance and repair work in the Repair Manual

(RepROM) that also accompanies your motorcycle.

Some of the work calls for special tools and a thorough knowledge of motorcycle technology. If you are in doubt consult a specialist workshop, preferably your authorised BMW Motorrad dealer.

Regular maintenance

Running-in check

The running-in check must be performed after two hours' operation and must be entrusted to a specialist workshop, preferably an authorised BMW Motorrad dealer. See the "Inspection instructions" in the Repair Manual (RepROM) for detailed descriptions.

Work to be performed

- Read out fault memory
- Check air-filter element

- Check for dirt in the clean-side chamber of the intake air silencer
- Check the fuel system
- Check the exhaust system
- Check the security of the threaded fasteners for frame, side stand and trim panels
- Check the cooling system
- Check the front and rear brake pads and brake discs for wear
- Visually inspect the brake pipes, brake hoses and connections
- Check the brake fluid level, front and rear
- Check the security of the spring strut and check for leaks
- Check the steering-head bearing
- Check and vent the telescopic forks
- Check the rear wheel swinging arm and the swinging-arm pivot bearings

- Lubricate the swinging-arm shaft
- Check the drive chain, chain guide, sprocket and pinion
- Check chain tension
- Check the tyres and wheels
- Check the freedom of movement of the throttle cable, check for kinks and chafing and check play

Basic service every 10 operating hours

A basic service is necessary after every ten operating hours. Consult a specialist workshop, preferably an authorised BMW Motorrad dealer. See the "Inspection instructions" in the Repair Manual (RepROM) for detailed descriptions.

Work to be performed

- Everything involved in the running-in check, plus:

- Change the engine oil and the oil filter
- Replace the air-filter element
- Check valve clearances (after the first ten operating hours, then every twenty 20 additional operating hours)
- Check the spark plug
- Check the clutch cable and clutch-lever play

Extended service every 70 operating hours

An extended service is necessary after every seventy operating hours. Consult a specialist workshop, preferably your authorised BMW Motorrad dealer. See the "Inspection instructions" in the Repair Manual (RepROM) for detailed descriptions.

Work to be performed

- Everything involved in the basic service, plus:
- Service the engine

- Change the brake fluid in all systems
- Service the front forks
- Service the spring strut

Maintenance for off-roading

High requirements

The requirements that off-road riding places on the motorcycle are high. In order to ensure trouble-free operation and prevent premature wear, it is essential to have all service work and cleaning carried out in accordance with the instructions issued by BMW Motorrad. Extreme operating conditions (e.g. wet and mud) can result in above-average wear, rendering constant checking of the wear parts necessary. In particular, the chain, spring strut and telescopic forks should be cleaned after every ride.

Always before off-riding

- Check the engine oil level (⇒ 65).
- Check the spark plug
- Check for dirt in the clean-side chamber of the intake air silencer
- Check the fuel system
- Check the exhaust system
- Check the security of the spring strut and check for leaks
- Check and vent the telescopic forks
- Check the drive chain, chain guide, sprocket and pinion
- Checking chain tension (⇒ 73).
- Check the tyres and wheels
- Check the spokes (⇒ 73).
- Check the freedom of movement of the throttle cable, check for kinks and chafing and check play

Always after off-riding

- Clean the motorcycle, in particular:
- Cleaning slider tubes (⇒ 74).
- Clean the spring strut (⇒ 75).
- Lubricate the chain (⇒ 73).
- Using plenty of clean water (garden hose), rinse off dirt and foreign matter from the brake calipers and the brake pads, front and rear.

Toolkit



- 1** Ring spanner
Width across flats 27/30
- 2** T-bar handle
Adapter for sockets
- 3** Sockets for Allen-head screws
Width across flats 8 and 10
- 4** Hook wrench
For adjusting spring pre-load
- 5** Open-ended spanner
Width across flats 10/13

- 6 Reversible-blade screwdriver with star-head and plain tips
- 7 Small screwdriver with plain tip
- 8 Spare fuses with puller tool
Miniature fuses, 7.5 A and 10 A

Engine oil

Checking engine oil level

- Check the engine oil once every hour, if possible.

 The engine can seize if the oil level is low, and this can lead to accidents.

Always make sure that the oil level is correct.◀

 The oil level varies with the temperature of the oil. The higher the temperature, the higher the level of oil in the sump. Checking the oil level with the engine cold or after no more than a short ride will lead to misinter-

pretation; this in turn, means that the engine will be operated with the incorrect quantity of oil. In order to ensure that the engine oil level is read correctly, check the oil level only after a lengthy trip.◀

- Allow the engine to idle until the fan starts up, then allow it to idle one minute longer.
- Switch off the engine.
- Make sure the engine is at operating temperature and hold the motorcycle upright.

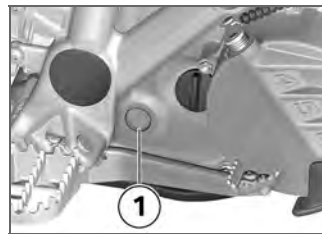

- Check the oil level in oil-level indicator **1**.

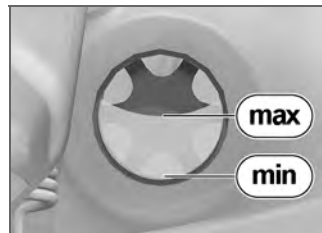

Engine oil, specified level

– Between MIN and MAX marks (Motorcycle is upright)

If the oil level is below the specified minimum:

- Top up the engine oil (➔ 66).

If the oil level is above the specified maximum:

- Have the oil level corrected by a specialist workshop, preferably an authorised BMW Motorrad dealer.

Topping up engine oil

- Make sure the ground is level and firm and place the motorcycle on its stand.

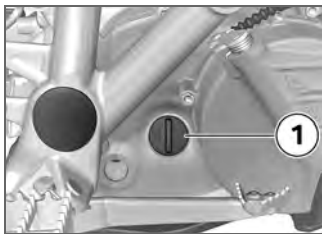

- Wipe the area around the filler neck clean.
- Remove cap **1** of the engine-oil filler neck by turning it counter-clockwise.

 Damage to the engine can result if it is operated without enough oil, but the same also applies if the oil level is too high.

Always make sure that the oil level is correct. ◀

- Top up the engine oil to the specified level.
- Check the engine oil level (➔ 65).

- Install the cap of the oil filler neck and turn it clockwise to close.

Brake system

Dependability of the brake system

A fully functional brake system is a basic requirement for the road safety of your motorcycle.

Do not ride the motorcycle if you have any doubts about the dependability of the brake system.

Under these circumstances have the brake system checked by a specialist workshop, preferably an authorised BMW Motorrad dealer.

 Incorrect working practices endanger the reliability of the brakes.

Have all work on the brake system performed by a specialist

workshop, preferably an authorised BMW Motorrad dealer. ◀

Checking operation of brakes

- Pull the handbrake lever.
 - » The pressure point must be clearly perceptible.
- Press the footbrake lever.
 - » The pressure point must be clearly perceptible.

No clearly perceptible pressure point:

- Bleed the brake circuit and check the brake system for damage.

Brake pads

Checking front brake pad thickness

 Brake pads worn past the minimum permissible thickness can cause a reduction in braking efficiency and under certain circumstances they can

cause damage to the brake system. In order to ensure the dependability of the brake system, do not permit the brake pads to wear past the minimum permissible thickness. ◀

- Make sure the ground is level and firm and place the motorcycle on its stand.

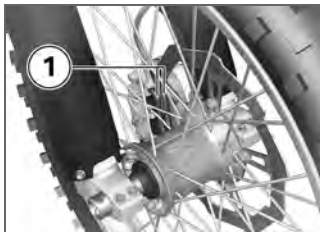

- Visually inspect brake pads **1** to ascertain their thickness. Viewing direction: Above the wheel axle through the fork tubes toward the brake caliper. If necessary, turn the front

wheel until the outboard brake pad is visible through the brake disc.

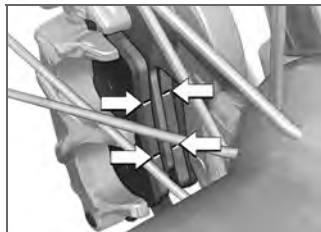

 Brake-pad wear limit, front

– min 1.0 mm (Friction pad only, without backing plate. The wear indicators (grooves) must be clearly visible.)

If the wear indicating mark is no longer clearly visible:

- Have the brake pads replaced by a specialist workshop,

preferably an authorised BMW Motorrad dealer.

Checking brake pad thickness, rear brakes



Brake pads worn past the minimum permissible thickness can cause a reduction in braking efficiency and under certain circumstances they can cause damage to the brake system.

In order to ensure the dependability of the brake system, do not permit the brake pads to wear past the minimum permissible thickness. ◀

- Make sure the ground is level and firm and place the motorcycle on its stand.

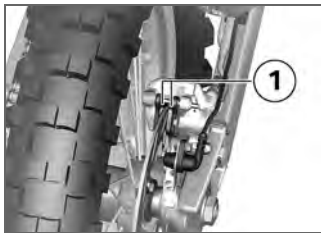

- Visually inspect brake pads **1** to ascertain their thickness.

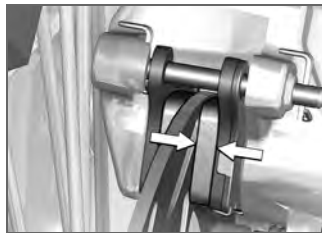

Brake-pad wear limit, rear

– min 1.0 mm (Friction pad only, without backing plate)

If the brake pads are worn:

- Have the brake pads replaced by a specialist workshop, preferably an authorised BMW Motorrad dealer.

Brake fluid

Checking brake-fluid level, front brakes



A low fluid level in the brake reservoir can allow air to penetrate the brake system. This significantly reduces braking efficiency.

Check the brake-fluid level at regular intervals.◀

- Make sure the ground is level and firm and hold the motorcycle upright.
- Move the handlebars to the straight-ahead position.

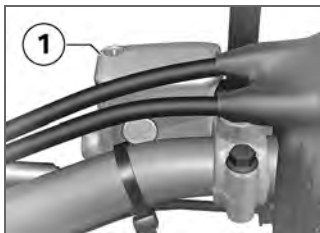

- Check the brake fluid level in front reservoir **1**.

▶ The brake fluid level in the brake fluid reservoir drops as the brake pads wear.◀



Brake fluid level, front (visual inspection)

– DOT4 brake fluid

– It is impermissible for the brake fluid level to drop below the MIN mark. (Brake-fluid reservoir horizontal)

If the brake fluid level drops below the permitted level:

- Have the defect rectified as quickly as possible by a specialist workshop, preferably an authorised BMW Motorrad dealer.

Checking brake-fluid level, rear brakes



A low fluid level in the brake reservoir can allow air to penetrate the brake system. This significantly reduces braking efficiency.

Check the brake-fluid level at regular intervals.◀

- Make sure the ground is level and firm and hold the motorcycle upright.

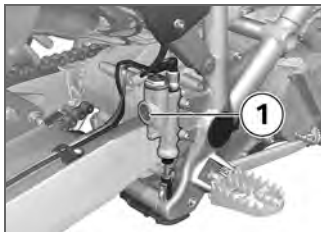

- Check the brake fluid level in reservoir **1**.

▶ Wear of the brake pads causes the brake fluid level in the reservoir to sink.◀



 Brake fluid level, rear (visual inspection)

– DOT4 brake fluid

– It is impermissible for an air bubble to be visible in the sight glass. (Motorcycle is upright)

If the brake fluid level drops below the permitted level:

- Have the defect rectified as quickly as possible by a specialist workshop, preferably an authorised BMW Motorrad dealer.

Coolant

Checking coolant level

- Make sure the ground is level and firm and hold the motor-cycle upright.

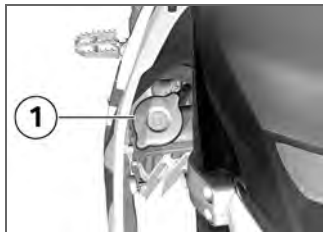

 Risk of burns from escaping coolant.

The hot cooling system is pressurised. Allow the coolant to cool down before opening the radiator cap. ◀

- Once the radiator has cooled, remove cap **1** by turning it counter-clockwise.

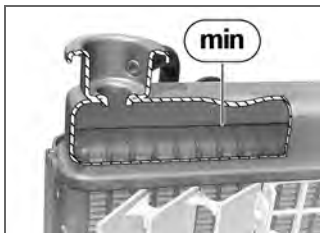

Coolant, specified level

- Antifreeze
- Top plates just covered by coolant (MIN level)
- 4 mm (MAX level, covering the top plates)

If the coolant level is too low:

- Top up the coolant.
- Install the radiator cap and turn it clockwise to close.

Topping up coolant

- Make sure the ground is level and firm and place the motor-cycle on its stand.

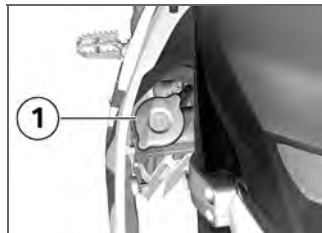

 Risk of burns from escaping coolant.

The hot cooling system is pressurised. Allow the coolant to cool down before opening the radiator cap. ◀

- Once the radiator has cooled, remove cap **1** by turning it counter-clockwise.

- Using a suitable funnel, top up with coolant until the level is correct.
- Check the coolant level (→ 71).
- Install the radiator cap and turn it clockwise to close.

Clutch

Checking operation of clutch

- Pull the clutch lever.
- » The pressure point must be clearly perceptible.

If the pressure point is not clearly perceptible:

- Have the clutch checked by a specialist workshop, preferably an authorised BMW Motorrad dealer.

Checking clutch-lever play

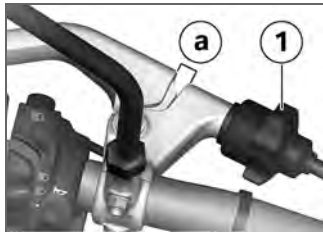

- Pull the clutch lever until resistance is perceptible.
- Measure clutch-lever play **a**.



Clutch-lever play

– 1 mm (Handlebars in straight-ahead position, between handlebar fitting and clutch lever)

Clutch-lever play is out of tolerance:

- Turn adjusting screw **1** to set clutch-lever play.

Tyres

Checking tyre tread depth



Your motorcycle's handling and grip can be impaired even before the tyres wear to the minimum tyre tread depth permitted by law.

Have the tyres changed in good time before they wear to the minimum permissible tread depth.◀

- Make sure the ground is level and firm and place the motorcycle on its stand.
- Measure the tyre tread depth in the main tread grooves with wear marks.



Tyres have wear indicators integrated into the main tread grooves. The tyre is worn out when the tyre tread has worn down to the level of the marks. The locations of the marks are indicated on the edge of the tyre,

e.g. by the letters TI, TWI or by an arrow.◀

If the tyre tread is worn to minimum:

- Replace tyre or tyres, as applicable.

Rims

Checking rims

- Make sure the ground is level and firm and place the motorcycle on its stand.
- Visually inspect the rims for defects.
- Have damaged rims checked and, if necessary, replaced by a specialist workshop, preferably an authorised BMW Motorrad dealer.

Checking spokes

- Make sure the ground is level and firm and place the motorcycle on its stand.

- Draw the handle of a screwdriver or a similar instrument across the spokes and listen to the notes of the individual spokes.

If the notes vary:

- Have the spokes checked by a specialist workshop, preferably an authorised BMW Motorrad dealer.

Chain

Lubricating chain



Dirt, dust and inadequate lubrication will result in accelerated wear and significantly shorten the drive chain's useful life.

Clean and lubricate the drive chain at regular intervals.◀

- Lubricate the drive chain every five operating hours at the latest. Lubricate the chain more frequently if the motor-

cycle is ridden in wet, dusty or dirty conditions.

- Switch the ignition off and select neutral.
- Clean the drive chain with a suitable cleaning product, dry it and apply chain lubricant.
- Wipe off excess lubricant.

Checking chain tension

- Make sure the ground is level and firm and place the motorcycle on its stand.
- Turn the rear wheel until it reaches the position with the lowest amount of chain sag.

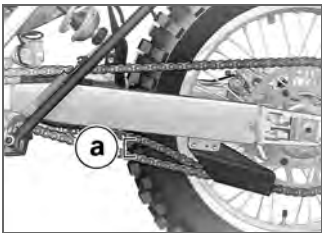

! If the chain is slack there will be more chain noise and the chain will wear more rapidly.

The design of the motorcycle permits it to be ridden with slight chain sag. It is important to ensure that chain sag is to specification. ◀

- Use a screwdriver to push the chain up and down and measure difference **a**.



Chain deflection

- 5 mm

If measured value is outside permitted tolerance:

- Adjust chain tension as described on the RepROM supplied with the motorcycle.

Checking chain wear

- Make sure the ground is level and firm and place the motorcycle on its stand.

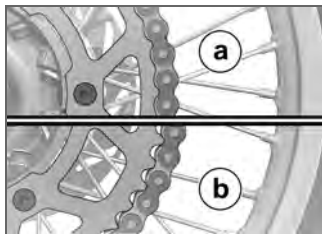

- Pull the chain back at the rear-most point of the sprocket.
- » The top of the teeth are still between the chain links (**a**): the chain is OK.

- » The chain is being pulled out over the top of the teeth (**b**): contact a specialist workshop, preferably an authorised BMW Motorrad dealer.

Telescopic forks

Cleaning slider tubes

- Make sure the ground is level and firm and place the motorcycle on its stand.



- Use plenty of water to wash out the space between the fork protectors and the slider tubes.

- In particular, be sure to remove dried dirt from bottom part **1** of the slider tubes. If necessary for better access, remove screws **2** and remove the fork protectors.
- Use a damp cloth to wipe clean the right and left slider tubes. In this process, be sure to pull the cloth through between the fork protector and the slider tube at the front.
- Use a dry cloth to wipe dirt off the sealing boots and slider tubes.
- Pack the groove of each sealing boot with grease.
 - Molykote 111
- Slide the sealing boots back up into position.

Spring strut

Cleaning spring strut



- Push left and right sealing boots **1** down.

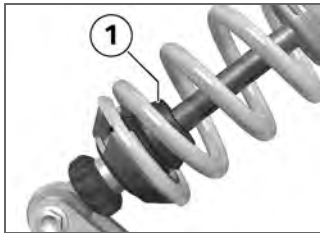



- Use plenty of clean water (garden hose) to rinse off dirt and foreign matter.
- Clean the spring strut with a gentle cleaning agent.

- Push up rubber stop **1** and clean the part of the strut normally covered by the stop.
- After cleaning it, spray the spring strut with oil.
 - Penetrating oil

Bulbs

General instructions

 A defective bulb places your safety at risk because it is easier for other users to oversee the motorcycle. Replace defective bulbs as soon as possible; always carry a complete set of spare bulbs if possible.◀

 The bulb is pressurised and can cause injury if damaged.

Wear protective goggles and gloves when changing bulbs.◀

▷ The types of bulb fitted to your motorcycle are listed in the section entitled "Technical data".◀

▷ Do not touch the glass of new bulbs with your fingers. Use a clean, dry cloth to hold the bulbs when handling them. Dirt deposits, in particular oil and grease, interfere with heat radiation from the bulb. This leads to overheating and shortens the bulb's operating life.◀

Replacing low-beam/high-beam headlight bulb



- Disengage retaining straps **1** of the light-top shield on left and right.
- Pull the light-top shield forward at the top edge.

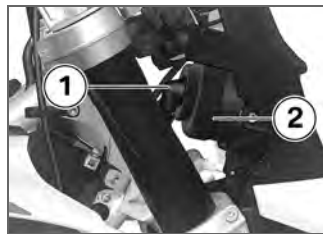

- Disconnect plug **1**.
- Remove rubber cap **2**.

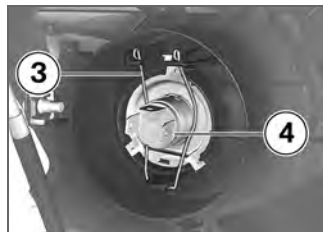

- Release spring clips **3** at top and bottom and swing them aside.
- Remove bulb **4**.

- Replace the defective bulb.

 Bulb for low-beam and high-beam headlight

– HS1 / 12 V / 35 W / 35 W

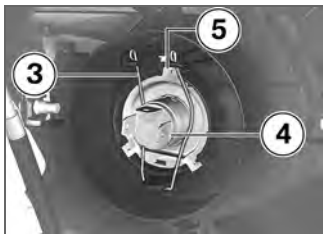

- Install bulb **4**, making sure that tab **5** is correctly positioned.
- Engage spring clip **3** in the catch.



- Install rubber cap **2**.
- Install plug **1**.



- Pull the tensioning straps **1** around the fork tubes and lock.

Replacing parking-light bulb



- Pull bulb socket **1** out of the headlight housing.

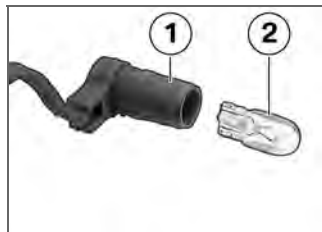

- Pull bulb **2** out of socket **1**.

- Replace the defective bulb.



Bulb for parking light

- W5W / 12 V / 5 W

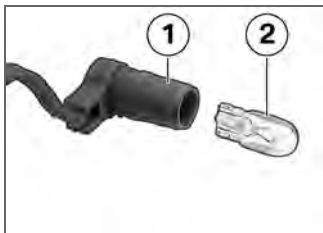

- Push bulb **2** into socket **1**.



- Insert bulb socket **1** into the headlight housing.

Replacing turn indicator bulbs, front and rear



If it is not standing firmly, the motorcycle could topple in the course of the operations described below.

Always make sure that the motorcycle is stable and firmly supported. ◀

- Make sure the ground is level and firm and place the motorcycle on its stand.





- Remove screw **1**.



- Pull the glass out of the reflector housing at the threaded-fastener side.



- Press bulb **2** into its socket and turn it counter-clockwise to remove.
- Replace the defective bulb.

 Bulbs for flashing turn indicators, front

- H6W / 12 V / 6 W



- Press bulb **2** into its socket and turn it clockwise to install.



- Working from the inboard side, insert the glass into the bulb housing and close the housing.



- Install screw **1**.

Fuses

Replacing secondary fuses



- Disconnect plug **1**.



- To do so, squeeze locking clips **2** together at top and bottom and disconnect the plug.



- Replace the defective fuse.



Fuse for lighting system

- 10 A



Fuse for radiator fan

- 7.5 A



- Connect plug **1**.

Replacing main fuse



- Disconnect plug **1**. Open cover **2** of the starter relay.



- To do so, squeeze retaining clips **3** together on left and right and lift the cover.

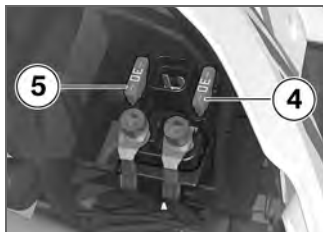

- Replace defective fuse **4**. If necessary, use spare fuse **5**.

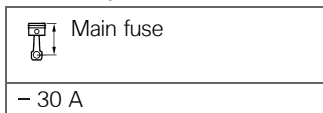

- Hold cover **2** in position. Connect plug **1**.

Battery

Maintenance instructions

Correct care, charging and storage will extend the service life of the battery. Always bear the following points in mind:

- Keep the surface of the battery clean and dry
- Do not open the battery
- Do not top up with water
- Comply with the instructions below for charging the battery

- Do not turn the battery upside down

Recharging battery

- Disconnect the battery from the on-board electrics.
- Charge the battery using a suitable charger.
- Comply with the operating instructions of the charger.
- Once the battery is fully charged, disconnect the charger's terminal clips from the battery terminals.

 The battery has to be recharged at regular intervals in the course of a lengthy period of disuse. See the instructions for caring for your battery. Always fully recharge the battery before restoring it to use◀

Instrument panel

Replacing battery of instrument panel



- Pull bulb socket **1** out of the headlight housing.



- Open retaining straps **2** on left and right.



- Remove screws **3**.



- Disconnect plug **4**.
- Remove the bulb carrier with the front mudguard.

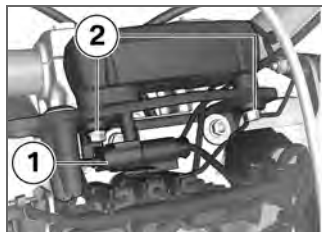

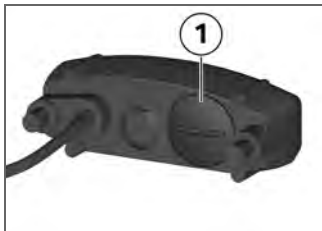

- Disconnect plug **1**.
- Remove screws **2**.

- Pull the instrument panel up and out of the holders.



- Turn battery-compartment cover **1** counter-clockwise to open.
- Remove the battery.
- Replace the spent battery.

 Battery type and rated voltage

- Lithium battery CR 2430
- 3 V



- Hold battery-compartment cover **1** in position and turn it clockwise to close.

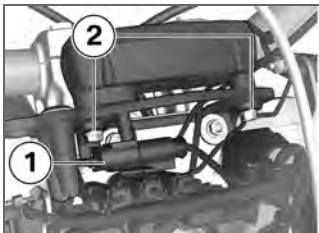

- Introduce the instrument panel into its holders.
- Install screws **2**.
- Connect plug **1**.



- Hold the bulb carrier with the front mudguard in position.
- Connect plug **4**.



- Install screws **3**.



- Pull retaining straps **2** round the fork legs on left and right and secure.

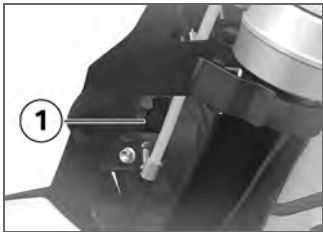

- Insert bulb socket **1** into the headlight housing.

Care

Care products	86
Washing motorcycle	86
Cleaning easily damaged components.....	86
Laying up motorcycle	87
Restoring motorcycle to use	87

Care products

BMW Motorrad recommends that you use the cleaning and care products you can obtain from your authorised BMW Motorrad dealer. The substances in BMW CareProducts have been tested in laboratories and in practice; they provide optimised care and protection for the materials used in your vehicle.



The use of unsuitable cleaning and care products can damage vehicle components. Do not use solvents such as cellulose thinners, cold cleaners, fuel or the like, and do not use cleaning products that contain alcohol.◀

Washing motorcycle

BMW Motorrad recommends that you use BMW insect remover to soften and wash off insects and stubborn dirt on

painted parts prior to washing the motorcycle.

To prevent stains, do not wash the motorcycle immediately after it has been exposed to strong sunlight and do not wash it in the sun.

Make sure that the motorcycle is washed frequently, especially during the winter months.

To remove road salt, clean the motorcycle with cold water immediately after every trip.



After the motorcycle has been washed, ridden through water or ridden in the rain, the brake discs and pads might be wet and the brakes might not take effect immediately.

Apply the brakes in good time until the brakes have dried out.◀



Warm water intensifies the effect of salt.

Use only cold water to wash off road salt.◀



The high pressure of steam cleaners can damage seals, the hydraulic brake system, the electrical system, and the seat. Do not use a steam jet or high-pressure cleaning equipment.◀

Cleaning easily damaged components

Plastics

Clean plastic parts with water and BMW plastic care emulsion. This includes in particular:

- Windscreen and slipstream deflectors
- Headlight lens made of plastic
- Glass cover of the instrument panel
- Black, unpainted parts



If plastic parts are cleaned using unsuitable cleaning

agents, the surfaces can be damaged.

Do not use cleaning agents that contain alcohol, solvents or abrasives to clean plastic parts.

Even fly-remover pads or cleaning pads with hard surfaces can produce scratches.◀

 Soften stubborn dirt and insects by covering the affected areas with a wet cloth.◀

Radiator

Clean the radiator regularly to prevent overheating of the engine due to inadequate cooling. For example, use a garden hose with low water pressure.

 Cooling fins can be bent easily.

Take care not to bend the fins when cleaning the radiator.◀

Rubber

Treat rubber components with water or BMW rubber-care products.

 Using silicone sprays for the care of rubber seals can cause damage.

Do not use silicone sprays or other care products that contain silicon.◀

Laying up motorcycle

- Clean the motorcycle.
- Remove the battery.
- Spray the brake and clutch lever pivots and the main and side stand pivots with a suitable lubricant.
- Coat bright metal and chrome-plated parts with an acid-free grease (e.g. Vaseline).
- Stand the motorcycle in a dry room in such a way that there is no load on either wheel. Authorised BMW Motorrad deal-

ers can provide suitable auxiliary stands.

 Before laying the vehicle up out of use, have the engine oil and the oil filter element changed by a specialist workshop, preferably an authorised BMW Motorrad dealer. Combine work for laying up/restoring to use with a BMW service or inspection.◀

Restoring motorcycle to use

- Remove the protective wax coating.
- Clean the motorcycle.
- Install a charged battery.
- Before starting: work through the checklist.

Technical data

Threaded fasteners	90
Engine	91
Fuel	92
Engine oil	92
Clutch	93
Transmission	93
Rear-wheel drive	94
Running gear	94
Brakes	95
Wheels and tyres	95
Electrics	96
Frame	97
Dimensions	97
Weights	98
Riding specifications	98

Threaded fasteners

Mirror arm	Value	Valid
Mirror to handlebar		
Locknut, M10 x 1.25	20 Nm	
Handlebars	Value	Valid
Handlebar clamping block with handlebars to fork bridge		
M10 x 70	38 Nm	
Handlebar clamping block		
M8 x 30	19 Nm	

Engine

Engine design	Single-cylinder four-stroke, double overhead camshafts, 4 valves, two operated by bucket tappets and two by cam followers, liquid-cooled cylinder and cylinder head, integral coolant pump, 5-speed gearbox.
Displacement	449.5 cm ³
Cylinder bore	98 mm
Piston stroke	59.6 mm
Compression ratio	12 : 1
Nominal output	30 kW, at engine speed: 7000 min ⁻¹
– with coded plug ^{AS}	38 kW, at engine speed: 9000 min ⁻¹
– with power reduction ^{OA}	19 kW, at engine speed: 7500 min ⁻¹
Torque	43 Nm, at engine speed: 6500 min ⁻¹
– with coded plug ^{AS}	44 Nm, at engine speed: 7800 min ⁻¹
– with power reduction ^{OA}	30 Nm, at engine speed: 5750 min ⁻¹
Idle speed	1850...1950 min ⁻¹

Fuel

Recommended fuel grade	95 ROZ/RON, Super unleaded
Usable fuel capacity	approx. 8 l
Reserve fuel	≥0.75 l

Engine oil

Oil consumption	max 0.1 l/h
Engine oil, capacity	max 1.15 l, with filter change
Engine oils, Permissible viscosity classes and products	
Castrol GPS SAE 10W-40	≥-20 °C
Oil grades	Mineral engine oils of API classification SF to SH. BMW Motorrad recommends not using oil additives, because they can have a detrimental effect on clutch operation. Please do not hesitate to contact your authorised BMW Motorrad dealer if you have any questions relating the choice of a suitable engine oil for your motorcycle.

Permissible viscosity classes

SAE 5 W-40	≥-30 °C, Operation at low temperatures
SAE 10 W-40	≥-20 °C, Operation at low temperatures
SAE 15 W-40	≥-10 °C

Clutch

Clutch type	Multiplate clutch running in oil bath
-------------	---------------------------------------

Transmission

Gearbox type	Claw-shift 5-speed gearbox, integrated into engine block
Gearbox transmission ratios	2,618, Primary transmission ratio 2.462 (13:32 teeth), 1st gear 1.706 (17:29 teeth), 2nd gear 1.350 (20:27 teeth), 3rd gear 1.043 (23:24 teeth), 4th gear 0.880 (25:22 teeth), 5th gear

Rear-wheel drive

Type of final drive	Chain drive
Type of rear suspension	Two-arm aluminium swinging arm
Final drive, number of teeth (Pinion / sprocket)	15 / 48

Running gear

Front wheel

Type of front suspension	Upside-down telescopic fork
Spring travel, front	300 mm, At wheel

Rear wheel

Type of rear suspension	Two-arm aluminium swinging arm
Type of rear suspension	Central spring strut with coil spring, adjustable compression- and rebound-stage damping
Spring travel, rear	320 mm, At wheel

Brakes

Type of front brake	Hydraulically actuated disc brake with 2-piston floating caliper
Brake-pad material, front	Sintered metal
Type of rear brake	Hydraulically actuated disc brake with 1-piston floating caliper
Brake-pad material, rear	Sintered metal

Wheels and tyres

Recommended tyre sets	You can obtain an up-to-date list of approved tyres from your authorised BMW Motorrad dealer or on the Internet at " www.bmw-motorrad.com ".
-----------------------	--

Front wheel

Front wheel, type	Spoked wheel
Front wheel rim size	1.60" x 21"
Tyre designation, front	90 / 90 - 21

Rear wheel

Rear wheel type	Spoked wheel
Rear wheel rim size	2.15" x 18"
Tyre designation, rear	140 / 80 - 18

Tyre pressures

Tyre pressure, front	1.2 bar, one-up, tyre cold
Tyre pressure, rear	1.2 bar, one-up, tyre cold
Tyre pressure for sport riding	1.0 bar

Electrics**Fuses**

Main fuse	30 A
Fuse for lighting system	10 A
Fuse for radiator fan	7.5 A

Battery

Battery, manufacturer and designation	Yuasa YTZ 7S
Battery type	AGM (Absorbent Glass Mat) battery
Battery rated voltage	12 V
Battery rated capacity	7 Ah

Spark plugs

Spark plugs, manufacturer and designation	NGK CR 9 EKB
Electrode gap of spark plug	0.8 ^{±0.1} mm, When new

Lighting

Bulb for low-beam and high-beam headlight	HS1 / 12 V / 35 W / 35 W
Bulb for parking light	W5W / 12 V / 5 W
Bulb for tail light/brake light	LED / 12 V
Bulbs for flashing turn indicators, front	H6W / 12 V / 6 W

Frame

Frame type	Bridge-type frame made of high-strength special steel with bolt-on rear frame
VIN location	Steering head, right

Dimensions

Length of motorcycle	2200 mm, Front-wheel to rear-wheel cover
Height of motorcycle	1475 mm, without rider, at DIN unladen weight, across mirrors
Width of motorcycle	806 mm, Across mirrors
Front-seat height	
– with low seat ^{OA}	935 mm, Without rider at unladen weight
	955 mm, Without rider at unladen weight

Weights

Unladen weight	121 kg, DIN unladen weight, ready for road, 90 % load of fuel, without optional extras
Permissible gross weight	280 kg
Maximum payload	159 kg

Riding specifications

Top speed	145 km/h
– with power reduction ^{OA}	117 km/h

Service

BMW Motorrad service	100
BMW Motorrad service quality	100
BMW Motorrad Service Card: on-the-spot breakdown assistance	100
BMW Motorrad service network	101
Maintenance work	101
Confirmation of maintenance work	102
Confirmation of service	107

BMW Motorrad service

Advanced technology requires specially adapted methods of maintenance and repair.



If maintenance and repair work is performed inexpertly, it could result in consequential damage and thus constitute a safety risk.

BMW Motorrad recommends you to have all the associated work on your motorcycle carried out by a specialist workshop, preferably an authorised BMW Motorrad dealer. ◀

Your authorised BMW Motorrad dealer can provide information on BMW services and the work undertaken as part of each service. Have all maintenance and repair work carried out confirmed in the "Service" chapter in this manual. Authorised BMW Motorrad dealers are supplied with the latest technical information and have

the necessary technical know-how. BMW Motorrad recommends that you contact your authorised BMW Motorrad dealer if you have questions regarding your motorcycle.

BMW Motorrad service quality

Along with its reputation for engineering quality and high reliability, BMW Motorrad is a byword for excellent quality of service.

To ensure that your BMW is always in optimum condition, BMW Motorrad recommends that you have the maintenance work required for your motorcycle carried out regularly, preferably by your authorised BMW Motorrad dealer. For generous treatment of claims submitted after the warranty period has expired, evidence of regular maintenance is essential.

Certain signs of wear, moreover, may otherwise not be noticed until it is too late to put them right at moderate cost. Your authorised BMW Motorrad dealer's mechanics know every detail of your motorcycle and can take remedial action if necessary before minor faults develop into serious problems. By having the necessary repairs done properly and in good time, you save time and money in the long run.

BMW Motorrad Service Card: on-the-spot breakdown assistance

In the event of a breakdown, the BMW Motorrad Service Card issued with each new BMW motorcycle enables you to access an extensive range of services such as breakdown assistance, motorcycle transportation etc. (details can differ from country to country). In the event of a break-

down, contact the Mobile Service organisation of BMW Motorrad. The specialists will provide the necessary advice and assistance. You will find important country-specific contact addresses and the after-sales service organisation phone numbers in the "Service Kontakt / Service Contact" brochures, along with information on Mobile Service and the dealership network.

BMW Motorrad service network

BMW Motorrad has an extensive after-sales service network in place to look after you and your motorcycle in more than 100 countries. In Germany alone, you have the best possible access to approximately 200 authorised BMW Motorrad dealers.

All information concerning the international dealership network can be found in the brochure

"Service Contact Europe" or "Service Contact Africa, America, Asia, Australia, Oceania".

Maintenance work

BMW Pre-delivery Check

Your authorised BMW Motorrad dealer conducts the BMW pre-delivery check before handing over the motorcycle to you.

BMW Running-in Check

The BMW running-in check must be performed after two operating hours have been logged.

BMW Service

A BMW service must be performed after every ten operating hours. The scope of the service can vary, depending on the total number of operating hours logged. Your authorised BMW Motorrad dealer confirms that the service work has been carried out and enters the operating hours

at which the next service will be due.

All maintenance work is described on the RepROM that accompanies the motorcycle.

Confirmation of maintenance work

BMW Pre-delivery Check

Completed

on _____

Stamp, signature

BMW Running-in Check

Completed

After op. hours _____

Odometer reading _____

Next service
at the latest

After op. hours _____

Stamp, signature

BMW Service

Completed

After op. hours _____

Odometer reading _____

Next service
at the latest

After op. hours _____

Stamp, signature**BMW Service**

Completed

After op. hours _____

Odometer reading _____

Next service
at the latest

After op. hours _____

Stamp, signature**BMW Service**

Completed

After op. hours _____

Odometer reading _____

Next service
at the latest

After op. hours _____

Stamp, signature

BMW Service

Completed

After op. hours _____

Odometer reading _____

Next service
at the latest

After op. hours _____

Stamp, signature**BMW Service**

Completed

After op. hours _____

Odometer reading _____

Next service
at the latest

After op. hours _____

Stamp, signature**BMW Service**

Completed

After op. hours _____

Odometer reading _____

Next service
at the latest

After op. hours _____

Stamp, signature

BMW Service

Completed

After op. hours _____

Odometer reading _____

Next service
at the latest

After op. hours _____

Stamp, signature**BMW Service**

Completed

After op. hours _____

Odometer reading _____

Next service
at the latest

After op. hours _____

Stamp, signature**BMW Service**

Completed

After op. hours _____

Odometer reading _____

Next service
at the latest

After op. hours _____

Stamp, signature

BMW Service

Completed

After op. hours _____

Odometer reading _____

Next service
at the latest

After op. hours _____

Stamp, signature**BMW Service**

Completed

After op. hours _____

Odometer reading _____

Next service
at the latest

After op. hours _____

Stamp, signature**BMW Service**

Completed

After op. hours _____

Odometer reading _____

Next service
at the latest

After op. hours _____

Stamp, signature

Confirmation of service

The table is intended as a record of maintenance and repair work, the installation of optional accessories and, if appropriate, special campaign (recall) work.

Item	Odometer reading	Date

A

- Abbreviations and symbols, 6
- Accessories
 - General instructions, 60

B

- Battery
 - Maintenance, 81
 - Maintenance instructions, 81
 - Position on the motorcycle, 11

BMW Motorrad service, 100

- BMW Motorrad Service
 - Card, 100

- Brake fluid
 - Checking fluid levels, 69
 - Reservoir, front, 13
 - Reservoir, rear, 13

- Brake pads
 - Checking brake-pad thickness, 67
 - Running in, 49

- Brakes
 - Checking operation, 66
 - Safety instructions, 52
 - Technical data, 95

Bulbs

- General instructions, 75
- Replacing high-beam headlight bulb, 76
- Replacing low-beam headlight bulb, 76
- Replacing parking-light bulb, 77
- Replacing turn indicator bulbs, 78
- Technical data, 97

C

- Chain
 - Checking tension, 73
 - Checking wear, 74
 - Lubricating, 73
- Checklist, 48
- Clutch
 - Checking operation, 72
 - Checking play, 72
 - Technical data, 93
- Confirmation of maintenance work, 102

Coolant

- Checking fill level, 71
 - Filler neck, 13
 - Topping up, 71
- Currency, 8

D

- Damping
 - Adjust the front rebound stage, 39
 - Adjust the rear rebound stage, 40
 - Adjuster, front, 11
 - Adjuster, rear, 11, 13
 - Adjusting, 39
 - Adjusting front compression stage, 40
 - Adjusting rear compression stage, 41
- Dimensions
 - Technical data, 97

E

- Electrics
 - Technical data, 96

E

- Engine
 - Control, 15
 - Increasing power, 50
 - Switching off, 48
 - Switching on, 48
 - Technical data, 91

E

- Engine oil
 - Checking fill level, 65
 - Fill-level indicator, 13
 - Filler neck, 13
 - Technical data, 92
 - Topping up, 66

E

- Engine rpm
 - Restrictions, 46
 - Warning, 19

F

- Frame
 - Technical data, 97

F

- Fuel
 - Filler neck, 11
 - Refuelling, 54
 - Technical data, 92
 - Warning, fuel down to reserve, 18

F

- Fuses, 11, 96
 - Replacing, 79

G

- General views
 - Left handlebar fitting, 14
 - Multifunction display, 18
 - Right handlebar fitting, 15
 - Right side of motorcycle, 13

H

- Handlebar fittings
 - General view, left side, 14
 - General view, right side, 15

H

- Handlebars
 - Adjusting, 33

H

- Headlight
 - Beam throw, 41
 - Headlight beam-throw adjustment, 11

H

- Headlight flasher, 14
- High-beam headlight
 - Control, 14
 - Switching on, 31
 - Telltale light, 18

H**I**

- Ignition
 - Switching on, 22
- Instrument cluster
 - Overview, 16
 - Replacing battery, 82

K

- Keys, 22

L

- Laying up, 87
- Lights
 - Headlight flasher, 31
 - Switch on the high-beam headlight, 31
 - Switching on the low-beam headlight, 31
 - Switching on the position lights, 31
- Low-beam headlight
 - Switching on, 31

M

Maintenance

- For off-roading, 63
- General instructions, 62
- Workshop work, 62

Maintenance intervals, 101

Mirrors

- Adjusting, 32

Motorcycle

- Laying up, 87
- Parking, 53
- Restoring to use, 87

Multifunction display, 16

- Controls, 16
- Operation, 23
- Overview, 18

O

Off-roading, 50

- Additional maintenance, 63

P

Parking, 53

R

Rear-wheel drive

- Changing transmission ratio, 51
- Technical data, 94

Refuelling, 54

Reserve volume

- Warning, 18

Restoring to use, 87

Running gear

- Technical data, 94

Running in, 49

S

Safety instructions

- Brakes, 52
- General, 46

Seat

- Installation, 42
- Removal, 42

Service, 100

Service Card, 100

Side light

- Switching on, 31

Spark plugs

- Technical data, 96

Spring preload

- Adjusting, 36
- Adjusting for rear wheel, 38
- Adjusting static sag, 36
- Adjusting weighted sag, 37

Spring strut

- Cleaning, 75

Starting, 48

Status indicators, 18

- See also warnings, 18

Warnings, 18

Steering lock, 22

T

Technical data

- Brakes, 95
- Bulbs, 97
- Clutch, 93
- Dimensions, 97
- Electrics, 96
- Engine, 91
- Engine oil, 92
- Frame, 97
- Fuel, 92
- Rear-wheel drive, 94

- Running gear, 94
 - Spark plugs, 96
 - Standards, 8
 - Transmission, 93
 - Weights, 98
 - Wheels and tyres, 95
 - Telescopic fork
 - Cleaning, 74
 - Telltale lights, 16
 - Overview, 18
 - Torques, 90
 - Transmission
 - Technical data, 93
 - Transportation
 - Lashing, 56
 - Turn indicators
 - Control, 14
 - Operation, 32
 - Telltale light, 18
 - Tyres
 - Checking tread depth, 72
 - Pressures, 96
 - Running in, 49
 - Technical data, 95
 - Top speed, 46
- V**
- Vehicle
 - General view, left side, 11
- W**
- Warnings, 18
 - Weights
 - Technical data, 98
 - Wheels
 - Checking rims, 73
 - Technical data, 95