

BAXI

User's Operating Instructions



Bioflo

Pellet Central Heating System Boiler

These instructions should be read in conjunction with the
Supplementary Instructions

Please keep these instructions in a safe place.
If you move house, please hand them over to the next occupier.

Baxi Bioflo 12 kW Granite
Baxi Bioflo 12 kW Pearl

© Baxi Heating UK Ltd 2010 All rights reserved. No part of this publication may be reproduced or transmitted in any form or by any means, or stored in any retrieval system of any nature (including in any database), in each case whether electronic, mechanical, recording or otherwise, without the prior written permission of the copyright owner, except for permitted fair dealing under Copyrights, Designs and Patents Act 1988.

Applications for the copyright owner's permission to reproduce or make other use of any part of this publication should be made, giving details of the proposed use, to the following address:

The Company Secretary, Baxi Heating UK Ltd,
Brooks House, Coventry Road, Warwick. CV34 4LL

Full acknowledgement of author and source must be given.

WARNING: Any person who does any unauthorised act in relation to a copyright work may be liable to criminal prosecution and civil claims for damages.

InfoWIN operating unit

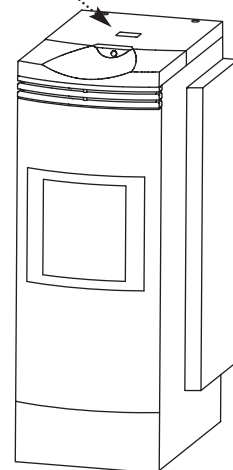

Important information for system operators5

1.1	Safety precautions	5
1.2	Fuel	5
1.3	Start-up and maintenance	6
1.4	Checking the heating water	6
1.5	Operating noises	6
1.6	Filling the pellet store	7
1.7	Sources of danger	8
1.7.1	Fire protection	8
1.7.2	Power failure (or if the blower is not running)	8
1.7.3	Burner pot	8

Operation9

2.1	Functional description, function elements and operating controls	9
2.1.1	BAXI Bioflo	9
2.1.2	Heat shield	10
2.2	Check before initial start-up	11
2.3	Filling the reserve supply container	11
2.3.1	BAXI Bioflo – Manual filling	11
2.4	Info panel	12
2.5	Operating modes	13
2.5.1	OFF mode	13
2.5.2	ON mode, lighting ON, self-test, lighting OFF	13
2.5.3	Pellet feed	14
2.5.5	Manual operation	15
2.5.6	Flue cleaning function	16
2.5.7	Shutdown procedure	16
2.6	Operating phases	17
2.6.1	Standby	17
2.6.2	Purging	17
2.6.3	Ignition phase	17
2.6.4	Flame stabilisation	17
2.6.5	Modulation mode	17
2.6.6	Burnout	17
2.6.7	Burner OFF	17
2.7	Information text	18
2.7.1	Next boiler cleaning	18
2.7.2	Operating hours	18
2.7.3	Pellet consumption total	19
2.7.4	Flue gas temperature	19
2.7.5	Boiler temperature setpoint	19
2.7.6	Current boiler output	19
2.7.7	Display module software version	19
2.7.8	Firing automate software version	19
2.7.9	Boiler model	19
2.8	Menu guide	20
2.8.1	Operator level	22
2.8.2	Service level	28
2.9	Heating system operation	29

Table of contents:

Page

Care, cleaning and maintenance43

3.1	Care of the front window, cladding and keyboard foil	.31
3.2	Cleaning and operating implements	.31
3.3	Overview of intervals between maintenance	.31
3.4	Heating surfaces	.33
3.5	Ash pan, ash on heating surface	.33
3.6	Combustion chamber	.34
3.6.1	Baffle plate, thermocontrol sensor	.34
3.6.2	Burner pot	.35
3.7	BAXI Bioflo reserve supply container	.36
3.8	Top heating surfaces and linkage	.37
3.9	Pressure measuring nipple, rotary feeder, blower wheel, blower box and exhaust pipe	.38
3.9.1	Pressure measuring nipple for combustion chamber pressure switch	.38
3.9.2	Rotary feeder	.38
3.9.3	Blower wheel, blower box and exhaust pipe to flue	.39

Troubleshooting40

4.1	No display on Info panel	.41
4.2	Information messages	.41
4.3	Fault messages	.42
4.4	Alarm messages	.43

Declaration of conformity47

Important information for system operator

1.1 Safety precautions

The boiler and related accessories are state of the art and meet all applicable safety regulations.

Your boiler and all accessories operate using 230 V AC electric current. Improper installation or repair can pose the danger of life-threatening electric shock. Installation may be performed only by appropriately qualified technicians.

Caution symbols

Please take careful note of the following symbols in this Operating Manual.



Ignoring the warnings identified can lead to **personal injury**.



Ignoring the warnings identified can lead to **malfunction of or damage to the boiler or heating system**.

1.2 Fuel

The boilers are designed to burn the following fuels:

Pellets according to ÖNORM M7135 and DIN *plus*.

Significant criteria based on the standards are as follows:

Diameter 6 mm	Length 80% between 15 – 30 mm
Smooth surface	Density at least 1.1 kg/dm ³
Residual moisture content max. 10%	Energy content min. 18 MJ/kg = 5 kWh/kg (in water-free condition)
Ash content max. 0.5%	Abraded particles max. 2.3%
Chemical/synthetic binding agents are strictly prohibited	No impurities from varnish or paint residues, etc.

The pellets must be stored in a dry place so that they can be transported without problems and in order to achieve trouble-free operation with optimum combustion and at maximum efficiency.

Important information for system operators

1.3 Start-up and maintenance

Have Baxi Customer Service or one of our customer service PARTNERS put your new boiler into service. In this way, all functions of the new unit will be thoroughly checked; you will also benefit from the detailed information provided by the system installer. Installation by a qualified technician as well as the maintenance required by the guarantee limitations will guarantee the optimal use and service life of your boiler system. This is the only way to assure the benefits of this technologically advanced boiler and guarantee safe, environmentally friendly and energy-saving system operation.

The following preconditions must be met before you commencing the initial start-up:

- 1.) Boiler installed correctly.
- 2.) System fully wired up electrically.
- 3.) System rinsed, filled and vented – heat consumption must be possible.
- 4.) Hot water tank connected to domestic water and filled.
- 5.) Sufficient quantity of fuel available (pellets, split logs, oil or gas).
- 6.) The customer must be present during start-up.

The initial start-up cannot be carried out if any of these points are neglected. The customer will be charged for any unnecessary costs arising as a result. Start-up and maintenance are part of the guarantee requirements as listed in the enclosed „guarantee limitations“.

Note: During the first few weeks after start-up, condensation can occur in the combustion chamber, on the heating surfaces and in the ash pan. This has no effect on the function and service life of the boiler.

1.4 Checking the heating water

The chemical composition of the heating water must meet the specifications of ÖNORM H 5195 Part 1 or VDI 2035 T1. According to ÖNORM M 5195 Part 1, the condition of the heating water must be checked every 2 years by a heating technician in order to avoid corrosion and sediment accumulation in the heating system.

The check must be performed once every year in heating systems with more than 1500 litres of heating water.

In the event of repair work requiring a change of water in the heating system, the heating water is to be checked within 4 to 6 weeks after such work. Corrosion and sediment resulting from improper heating water are not covered by the guarantee and warranty.

1.5 Operating noises

The BAXI Bioflo is a modern, fully automated pellet central heating boiler for living areas with a high level of convenience in terms of operation and cleaning. This automation means that operating noises may occur during normal operation.

Normal operating noises are:

Flame noises – Natural flame noise can be heard depending on the size of the combustion rate.

Light scratching and scraping noises – Depending on the level of contamination, cleaning noises may occur during automated cleaning or shake-out. If these become louder over time ⇒ Clean the pellet central heating boiler for living areas, especially the burner pot.

Trickling of pellets and vacuum cleaner noise – Fully automated pellet supply involves pellets being sucked from the storage room into the reserve supply container. During filling, the suction turbine generates a „vacuum cleaner noise“ in the storage room and the feed hose, and the trickling of the pellets can be heard in the reserve supply container.

Clicking noises – The relays switch on or off when the control unit is installed.

Liquid noise, gurgling – This is caused by air in the heating water ⇒ Bleed the system.

Air induction noises – Air induction noise occurs at the air supply induction point for combustion (air opening in the device) ⇒ Use air supply pipes to relocate the induction point outside the house or into an adjacent room.

Note: Due to these operating and flame noises, we do not recommend installing the device in bedrooms or quiet rooms – see also the information in the BAXI Bioflo Assembly instruction , „Installation“.

Important information for system operators

1.6 Filling the pellet store



The pellet flue-connected stove must be switched off **correctly** at least 15 minutes before the store is filled – Fig. 2. **Press the ON/OFF button. Never switch off using the emergency OFF switch!**

Pressing one of the six buttons firstly switches just the lighting and display on. The boiler is only switched off when the button is pressed for the 2nd time. Wait until burnout mode has finished (not indicated on the display) and open the combustion chamber doors.

During filling, negative pressure is created in the pellet store and this can cause burn-back in the pellet boiler. Therefore, the boiler must be stopped from operating during the filling procedure.



Fig. 2 Switching off FireWIN

Important information for system operators

1.7 Sources of danger

1.7.1 Fire protection

The entire system must comply with technical fire protection requirements in accordance with the applicable regulations, standards and guidelines.

All flammable materials in the close vicinity of the pellet central heating boiler for living areas must be protected against the effects of heat, in particular in the area of the front window.



Do not drape clothing or other items over the BAXI Bioflo for drying them.



Do not touch the front window – danger of burns.

1.7.2 Power failure (or if the blower is not running)



Do not open the combustion chamber door, there is an increased risk of deflagration when opening the combustion chamber door. A self-test is performed following a power failure during combustion and then operation is continued automatically.

1.7.3 Burner pot



Never fill the burner pot with pellets by hand. Excessive combustion material in the burner pot means that the pellets will not be ignited optimally. Too much low temperature carburisation gas will be generated and this can lead to deflagration.

Operation

2.1 Functional description, function elements and operating controls

The BAXI Bioflo automatically fires when the control system signals a heating requirement. Following „purging“ (safety function), ignition starts and the pellet metering auger switches on. The burner pot is automatically filled with pellets. When flame formation has been detected (by the thermocontrol sensor), the boiler enters flame stabilisation mode and then control mode (modulation mode) and keeps to the specified boiler temperature setpoint (between 60 °C and 75 °C). The boiler enters burnout mode if the output drops below the minimum nominal thermal output or no heating requirement is signalled by the control system. The blower continues to run until the burner pot has cooled down. Therefore, do not switch off the electricity supply to the device too soon.

2.1.1 BAXI Bioflo

The reserve supply container is loaded by hand. The heating surfaces are cleaned manually using the cleaning lever. The cleaning residues from the heating surfaces and the combustion residues from the burner pot drop into the ash pan or ash pan space.

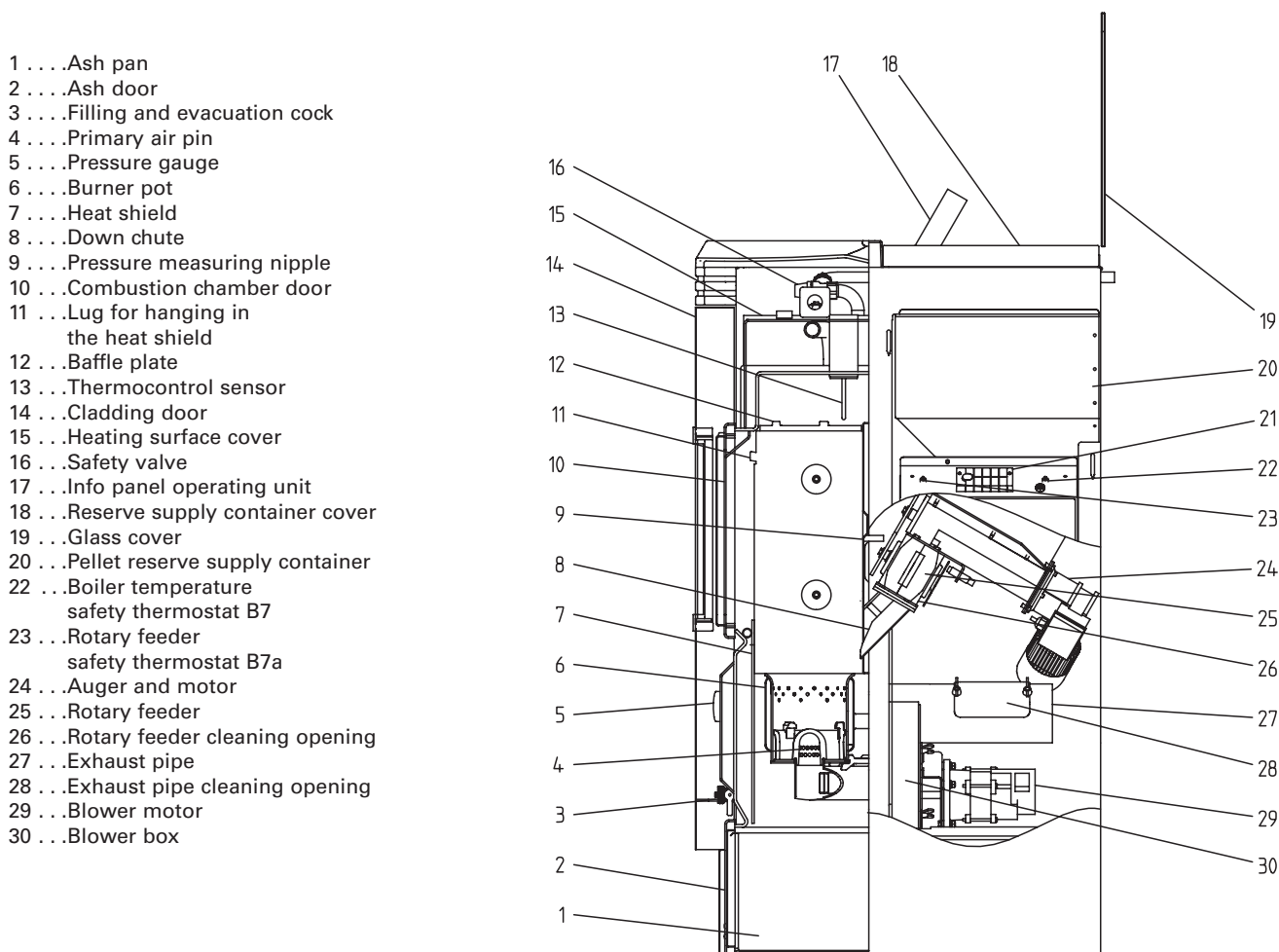

Fig. 3 BAXI Bioflo – view from right

Operation

2.1.4 Heat shield (accessory FIRE 023)

Heat radiated from the front window can lead to unwanted heating of the room where the unit has been set up when domestic hot water is being heated during the summer. If you do not want the room to be heated, you can significantly reduce the amount of heat radiated using the patented heat shield (accessory Fire 023).

The air-to-water ratio without a heat shield is approx. 15 : 85 % and with a raised heat shield approx. 9 : 91 %.

The heat shield is located in the combustion chamber. This can be pulled up using the supplied Allen key and hooked into the lugs on the sides of the combustion chamber cover plates, Figs. 4, 5.



Fig. 4 Hooking in the Allen key



Fig. 5 Pulling up the heat shield and hooking it into the lugs on the sides

Operation

2.2 Check before initial start-up

a) System pressure (heating water pressure):

The system must be filled and vented. With the system cold, pressure should be at least 1.0 bar (maximum 1.8 bar) – Fig. 6 If you have any questions, your installer will gladly answer them.

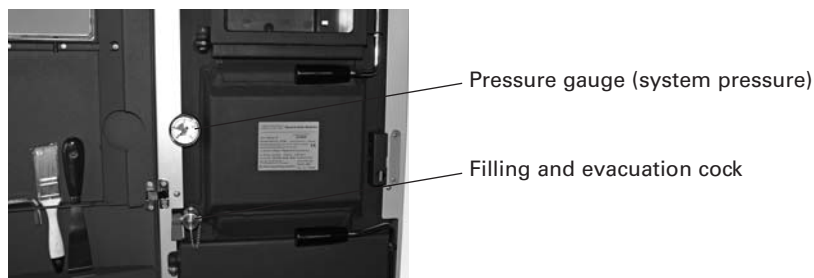

Fig. 6 Filling the system

b) Ventilation:

If you are operating the device with room air, please make sure the room where it is installed is well ventilated. The air supply must be as free of dust as possible.

c) Flue:

Please have the chimney sweep check the flue, and, if necessary, clean it.

2.3 Filling the reserve supply container

2.3.1 BAXI Bioflo – Manual filling

Note: Do not open the reserve supply container cover unless the glass cover is closed, in order to avoid damaging the glass cover.

Fold open the cover of the reserve supply container (Fig. 7) and fill the reserve supply container up to max. 1 cm below the edge. Close the cover.

Tip: The reserve supply container should always be completely filled with pellets. This allows the incoming pellets to drop into the container better, reduces the size of the conical part of the pile and means that the container empties better.



When filling, make sure no extraneous materials (e.g. shreds of the pellet bags resulting from cutting open the bags) enter the reserve supply container – they could block the rotary feeder!



Fig. 7 Folding open the cover

Operation

2.4 Info panel

The Info panel is located at the top under the glass cover. Press the locking button at the front and fold the glass cover open, the Info panel pops up automatically – Figs. 8, 9. It consists of a large full text display, an ON/OFF button with an LED signal lamp indicating Operation (green) or Malfunction (red), a button for manual operation / flue cleaning function as well as four individual menu buttons. The function of each menu button is displayed on the Menu line.



Fig. 8 Press the locking button



Fig. 9 Info panel pops up

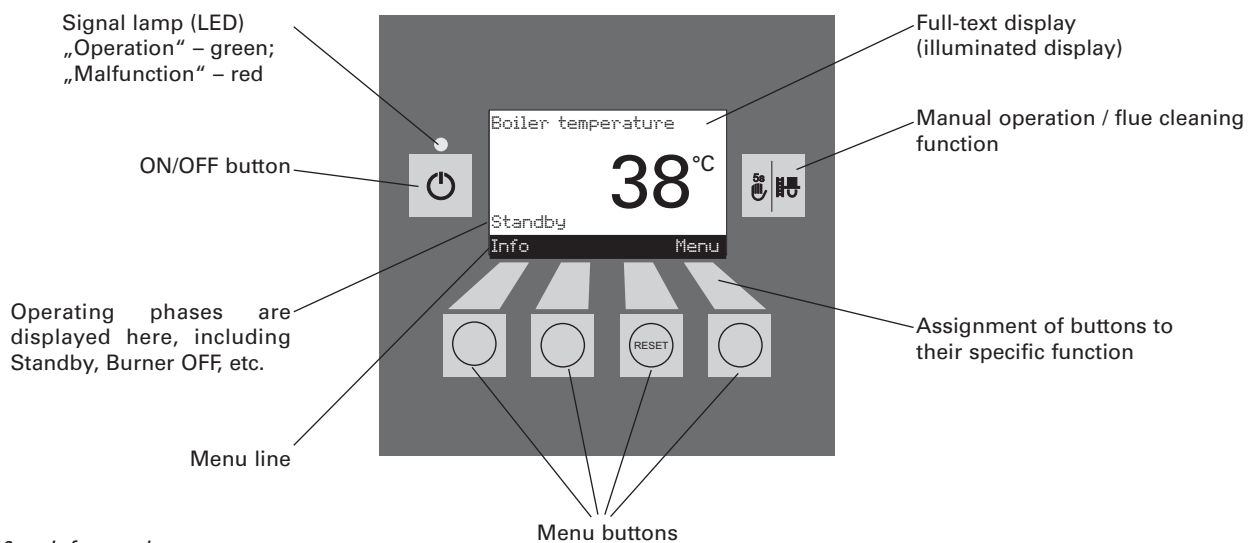

Fig. 10 Info panel

The various operating modes are displayed on Info panel together with the corresponding operating phases.

The following **operating modes** exist:

- OFF
- ON (with self-test, lighting ON, lighting OFF)
- Pellet feed
- Solid fuel / buffer mode
- Manual operation
- Flue cleaning function
- Shutdown procedure



Corresponding **operating phases**:

- Standby
- Purging
- Ignition phase
- Flame stabilisation
- Modulation mode
- Burnout
- Burner OFF
- Switch off heat generator

Operation

2.5 Operating modes

2.5.1 OFF mode

The boiler is switched off when in OFF mode. The display and all buttons, with the exception of the *ON/OFF* button, do not function. The LED on the Info panel is not illuminated – Fig. 11.

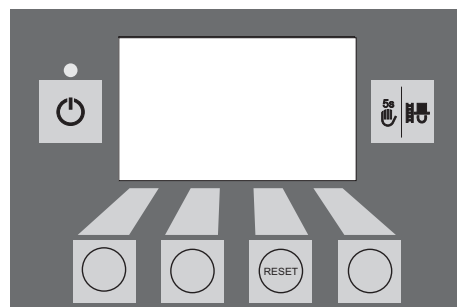

Fig. 11 OFF mode

2.5.2 ON mode, lighting ON, self-test, lighting OFF

Press the *ON/OFF* button, lighting and display are switched on and the self-test starts automatically – Fig. 12.

Self-test:

Sensors, switches and motors are checked during the self-test.

After a successful self-test, the display shows an operating phase and the boiler water temperature (standard display). The LED signal lamp lights green and the desired functions can be selected using the buttons – Fig. 13.

If the self-test was unsuccessful, an information message (e.g. information, fault, alarm) is displayed (see sections 4.3 and 4.4).

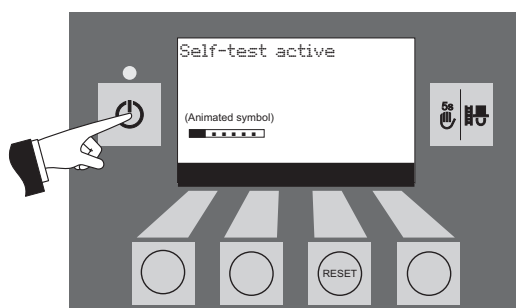

Fig. 12 Self-test

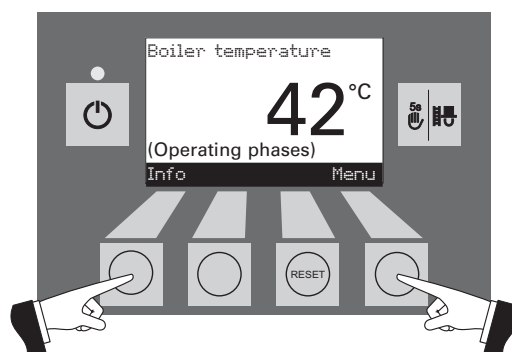

Fig. 13 Standard display

Lighting ON/OFF

The display lighting switches off automatically after 10 min. (Fig. 14). Pressing one of the six buttons switches the lighting on again for 10 min.

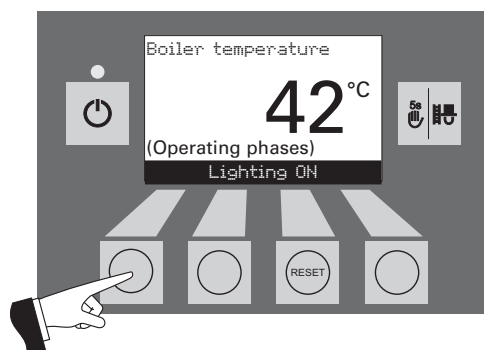

Fig. 14 Display lighting OFF

Info panel identifies and stores the various operating modes and states. Once the system is switched on, other operating modes may also be displayed instead of the standard display, such as manual operation or solid fuel/buffer mode; malfunctions are also displayed. These operating modes and states are described later in these instructions.

Operation

2.5.3 Pellet feed

Pellet feed – Burnout

Pellet feed from the storage room into the reserve supply container has been requested. Combustion is stopped. Pellet transport into the burner pot is stopped, the vacuum fan continues to run until all the remaining pellets have been burned and the burner pot has cooled down. – Fig. 15



Fig. 15

Pellet feed in operation

The pellet feed is in operation. Pellets are supplied from the storage room into the reserve supply container. The burner is locked – Fig. 16.



Fig. 16

Operation

2.5.5 Manual operation

Pressing one of the six buttons switches the lighting and display on. Manual operation starts if the Manual operation / flue cleaning function button is pressed for more than five seconds – Fig. 17. This sets the boiler temperature to the setpoint fixed for manual operation (standard value 60 °C). The control system is not affected by this. The lighting is switched off after the lighting timer has counted down (10 min.); the function or display remains unchanged.

The various operating phases are displayed here, including Burner in operation, Burner OFF, etc.

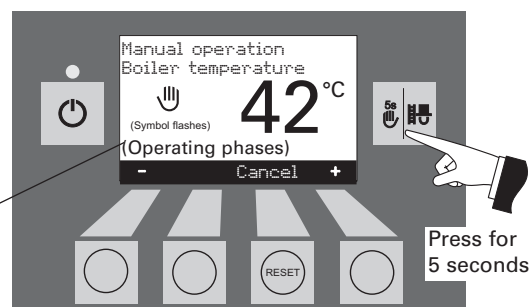

Fig. 17

Pressing the *Cancel* button or the *Manual operation / flue cleaning function* button terminates the function – Fig. 18. The boiler returns to automatic operation.

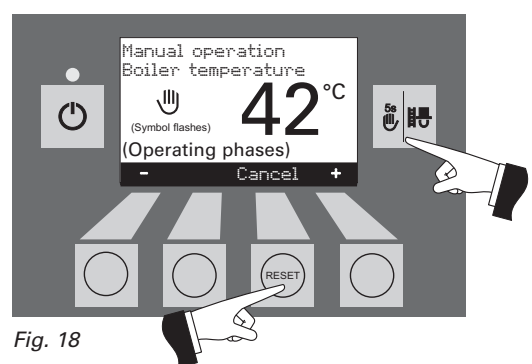

Fig. 18

Setpoint adjustment for manual operation

By pressing the + or – button the display switches to the set temperature adjustment mode – Fig. 19. Use the + or – button to change the setpoint in 1 K steps. The temperature set in this mode is not permanently saved. The original set temperature is used once manual operation ends.

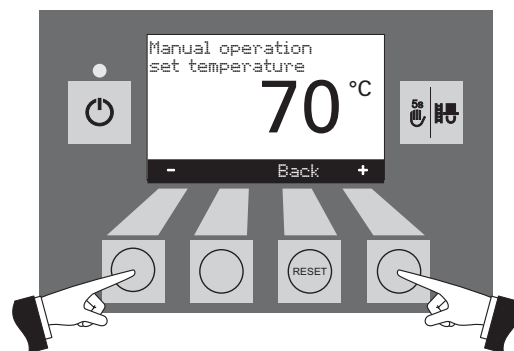

Fig. 19

By pressing the *Back* button (Fig. 20) or after waiting 45 seconds, the screen returns to its previous display.

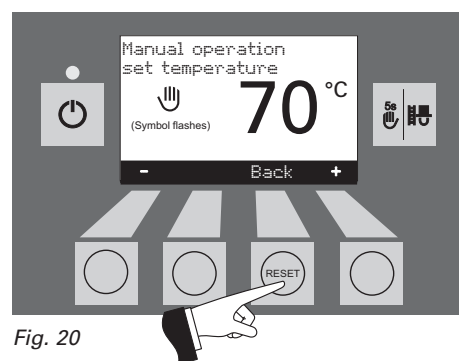

Fig. 20

Operation

2.5.6 Flue cleaning function

This function aids the performance of legally-required emissions testing.

Briefly pressing the *Manual operation / flue cleaning function* button switches on the display illumination. Pressing the button again starts the flue cleaning function – Fig. 21. The boiler temperature is set to approx. 60 °C for 45 min.

The various operating phases are displayed here, including Burner in operation, Burner OFF, etc.

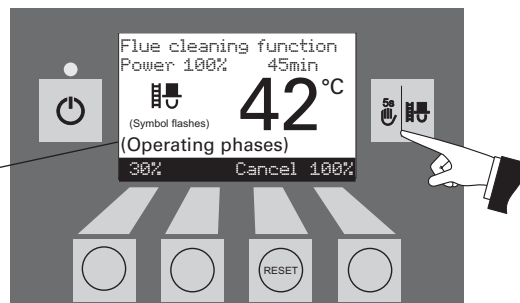

Fig. 21

Pressing the corresponding menu button enables the boiler to be operated with 30 % or 100 % output – Fig. 22. The lighting is switched off after the lighting timer has counted down (10 min); the function or display remains unchanged. When the button is first pressed only the lighting is switched on.

When the *Manual operation / flue cleaning function* button is pressed again the operating time is reset to 45 min.

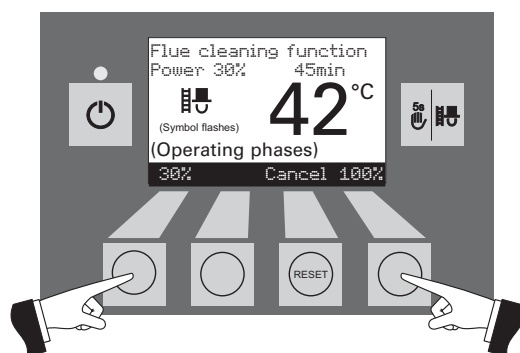

Fig. 22

The flue cleaning function ends

- when the *Cancel* button is pressed – Fig. 23.
- automatically after about 45 minutes.

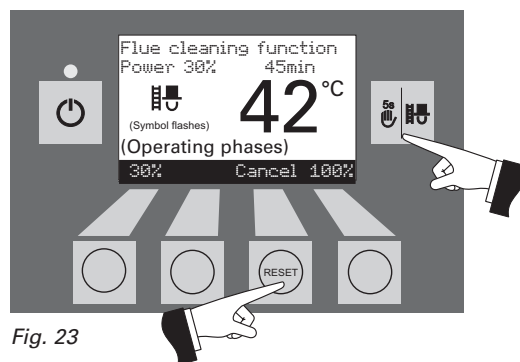

Fig. 23

2.5.7 Shutdown procedure

The boiler is switched off – Fig. 24.

The green LED flashes

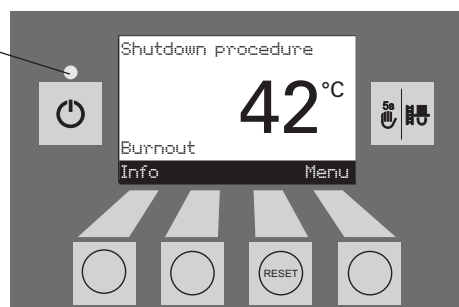

Fig. 24

Operation

2.6 Operating phases

2.6.1 Standby

During this operating phase, the control system does not transmit requests for heat. The burner is switched off and the boiler temperature setpoint is 0 °C – Fig. 25.

After an hour in standby mode, the display is shut down fully and only the green LED is lit up. The display is switched back on by pressing a button or when there is a heating requirement.

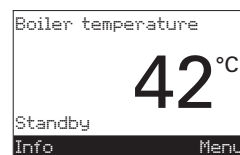

Fig. 25

2.6.2 Purging

The vacuum fan runs, the combustion chamber of the BAXI Bioflo is flushed through with fresh air. This phase can last several minutes before the burner fires – Fig. 26.

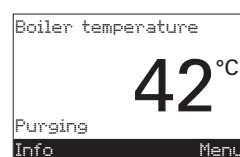

Fig. 26

2.6.3 Ignition phase

The vacuum fan runs, pellets are transported into the burner pot and are ignited. When flame formation is detected, the system switches over to flame stabilisation – Fig. 27.

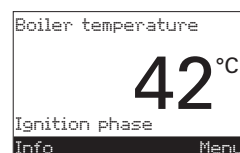

Fig. 27

2.6.4 Flame stabilisation

Following the ignition procedure, uniform combustion is established and then the system switches over to modulation mode – Fig. 28.

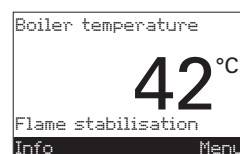

Fig. 28

2.6.5 Modulation mode

The burner is in modulation mode. The output can be infinitely varied between 30 % and 100 % – Fig. 29.

Note: In the modulation mode briefly no flame can be visible during the automatic burner ash removal!

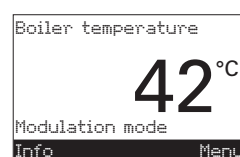

Fig. 29

2.6.6 Burnout

Combustion is stopped. Pellet transport into the burner pot is stopped, the vacuum fan continues to run until all the remaining pellets have been burned and the burner pot has cooled down – Fig. 30.

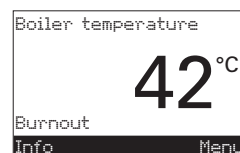

Fig. 30

2.6.7 Burner OFF

There is a heating requirement from the control system, but the boiler temperature (actual value) is higher than the boiler temperature setpoint. This means combustion is stopped and the burner is switched off – Fig. 31.

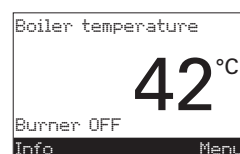

Fig. 31

Operation

2.7 Information text

Pressing the *Info* button calls up the most important BAXI Bioflo information – Fig. 32.

The *arrow* buttons select and display sub-menus – Fig. 33. By pressing the *Back* button (Fig. 34) or waiting 45 seconds, the screen returns to the standard display.

The following **information texts** exist:

- Next boiler cleaning in about[h]
- Operating hours [h]
- Pellet consumption total [t]
- Flue gas temperature [°C]
- Boiler temperature setpoint [°C]
- Current boiler output [%]
- Display module software version
- Firing automate software version
- Boiler model

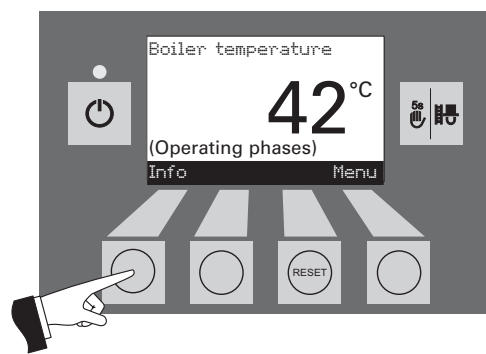

Fig. 32

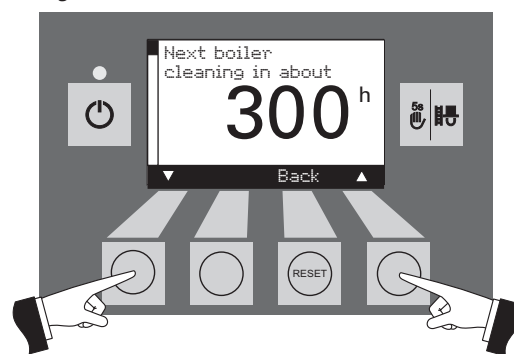

Fig. 33

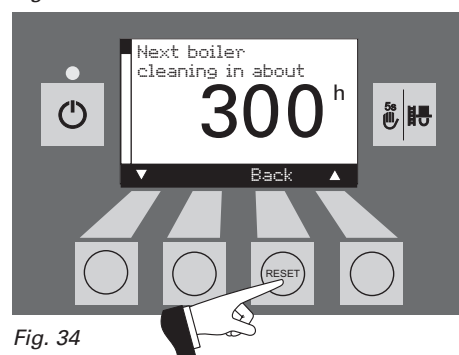

Fig. 34

2.7.1 Next boiler cleaning

Display showing the operating time in hours remaining until the next boiler cleaning – Fig. 35.

Note: The operating time remaining until the next boiler cleaning depends on the operating method and is constantly recalculated. Therefore, there may be deviations from the normal operating hours.



Fig. 35

2.7.2 Operating hours

The total number of burner operating hours is displayed – Fig. 36

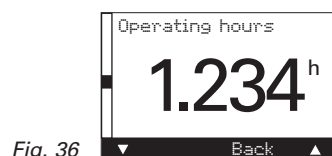

Fig. 36

Operation

2.7.3 Pellet consumption total

The total amount of pellets consumed is displayed in tonnes – Fig. 37.

Note: The „Pellet consumption total“ is a calculated value and can differ from the actual value by $\pm 15\%$.



Fig. 37

2.7.4 Flue gas temperature

If a flue gas temperature sensor (accessory) is connected, this function displays the current flue gas temperature – Fig. 38.

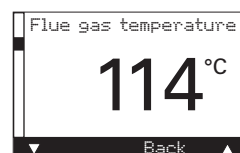

Fig. 38



The flue gas temperature is measured directly on the flue outlet. It may therefore deviate from a standard measurement.

2.7.5 Boiler temperature setpoint

The display indicates the boiler temperature setpoint as calculated by the control system. This setpoint is used to control the burner – Fig. 39.

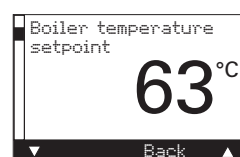

Fig. 39

2.7.6 Current boiler output

The current boiler output is displayed in %. The boiler output (modulation mode) can be set from 30 % to 100 % – Fig. 40.

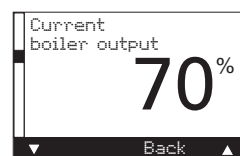

Fig. 40

2.7.7 Display module software version

The current software version of the display module (Info panel) is displayed – Fig. 41.



Fig. 41

2.7.8 Firing automate software version

The current software version of the firing automate (main PCB) is displayed – Fig. 42.



Fig. 42

2.7.9 Boiler model

The boiler model of the BAXI Bioflo is displayed – Fig. 43.



Fig. 43

Operation

2.8 Menu guide

Pressing the *Menu* button changes the menu display to operator level or service level – Fig. 44.

Use the *arrow* buttons to select the operator level or service level (Fig. 45) and confirm with the *Choose* button – Fig. 46.

The menu item or sub-menu item is exited by pressing the *Back* button (Fig. 47) or after a delay of 45 seconds.



Only trained service personnel may perform system modifications in the service level.

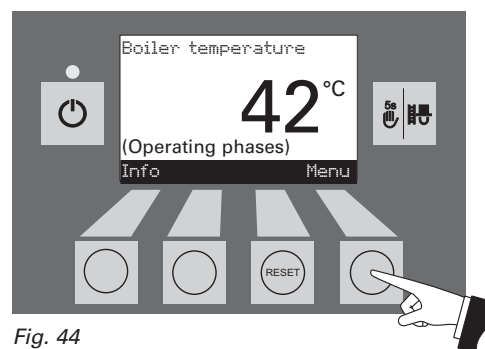

Fig. 44

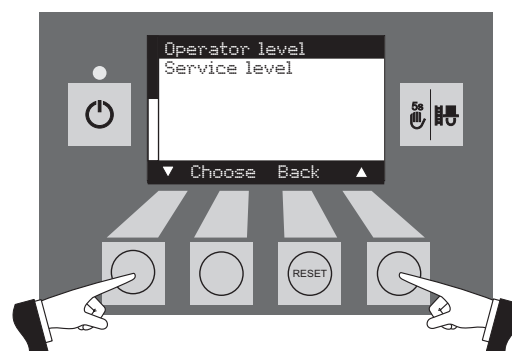

Fig. 45



Fig. 46

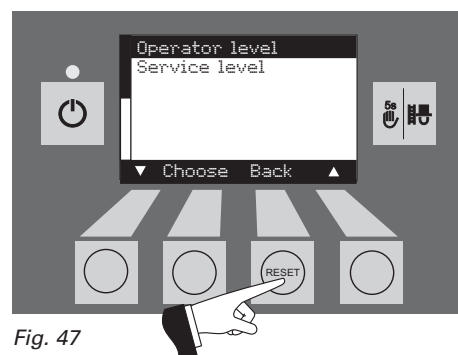
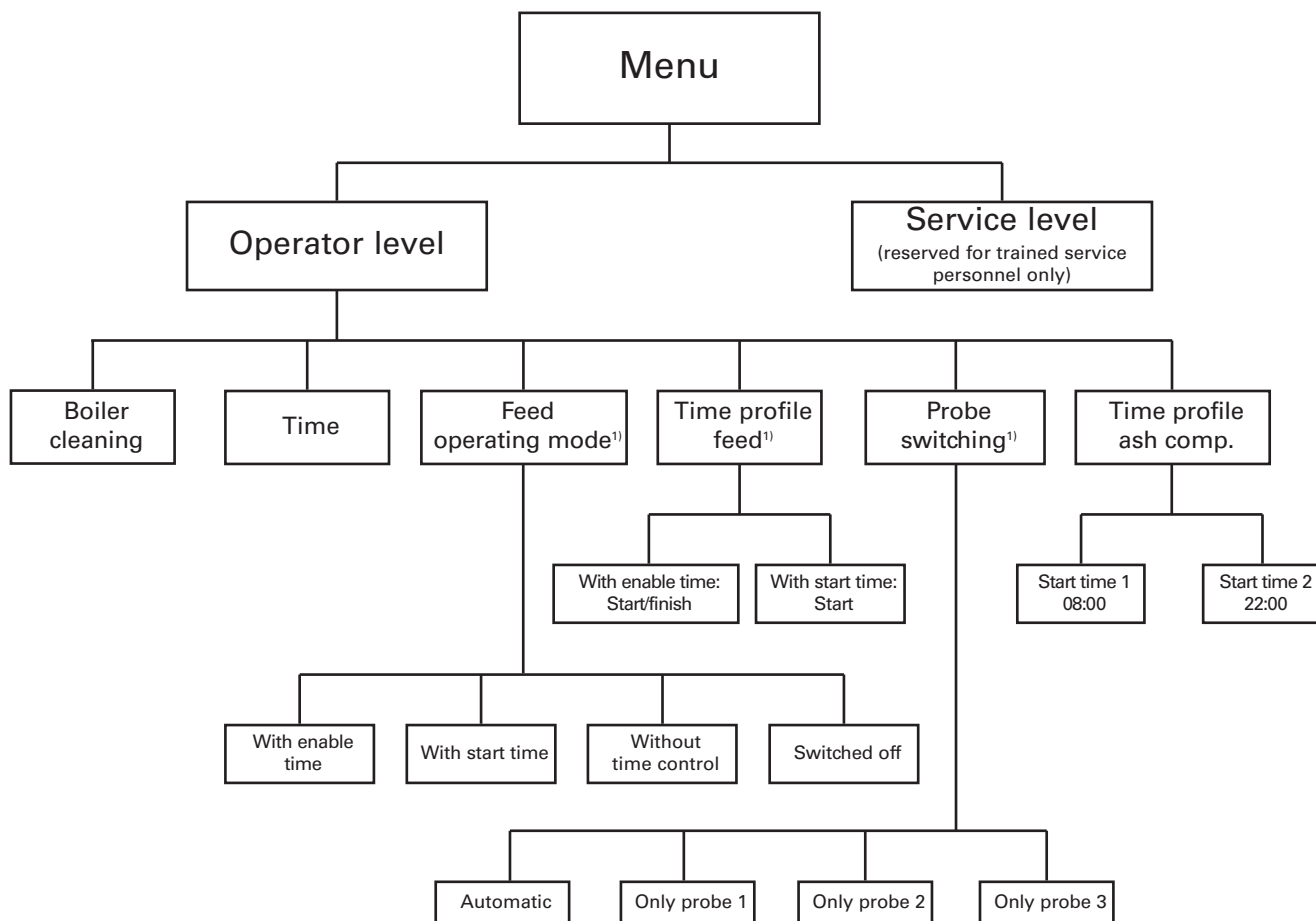

Fig. 47

Operation

Menu structure:



¹⁾ Only displayed if a feed system is present and if this has been adjusted by a trained service technician in the service level.

Operation

2.8.1 Operator level

Pressing the *Menu* button changes to the „Operator level“ and „Service level“ – Fig. 48.

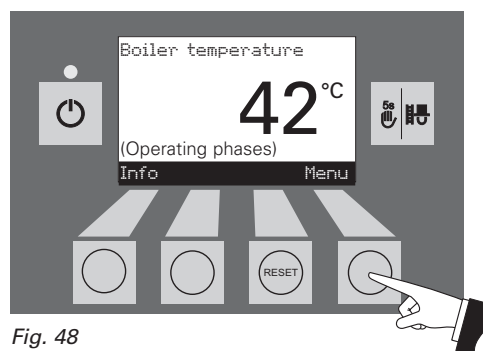

Fig. 48

Use the *arrow* buttons to select „Operator level“ and confirm with the *Choose* button – Fig. 49.

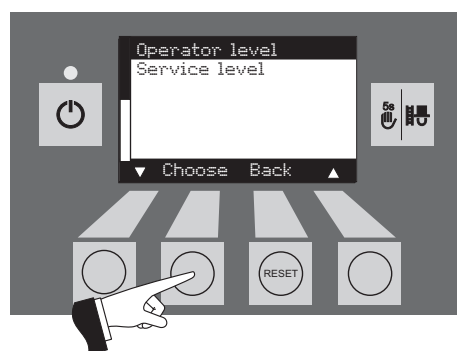

Fig. 49

In the operator level, use the *arrow* buttons to select the required sub-menu (Fig. 50) and confirm with the *Choose* button.

Adjusting the:

Boiler cleaning: 2.8.1.1

Time: see section 2.8.1.2.

Feed operating mode: see section 2.8.1.3.

Time profile feed: see section 2.8.1.4.

Probe switching: see section 2.8.1.5.

Time profile ash compression : see section 2.8.1.6

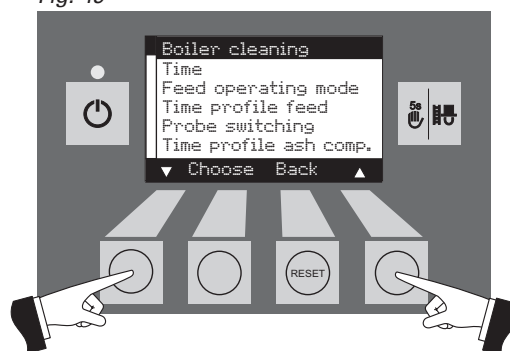

Fig. 50

The menu item or sub-menu item is exited by pressing the *Back* button (Fig. 51) or after a delay of 45 seconds.

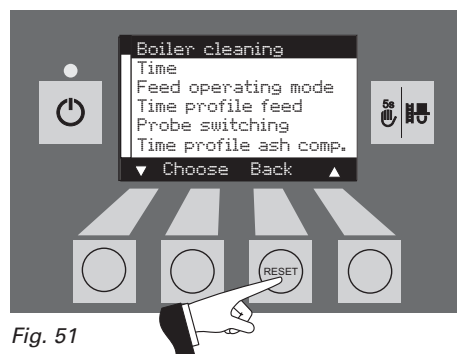

Fig. 51

Operation

2.8.1.1 Boiler cleaning - Resetting the cleaning request

After boiler cleaning has been performed (section 3.1), boiler cleaning must be confirmed so that the operating time until the next boiler cleaning is restarted.

i **Boiler cleaning must not** be reset if cleaning has not been carried out.

Pressing one of the six buttons switches the lighting and display on – Fig. 52.

Press the *Menu* button – Fig. 53.

Confirm the selected menu item „Operator level“ by pressing the *Choose* button – Fig. 54.

Use the *arrow* buttons to select the „Boiler cleaning“ sub-menu item – Fig. 55.

Confirm the selected „Boiler cleaning“ sub-menu item by pressing the *Choose* button – Fig. 56

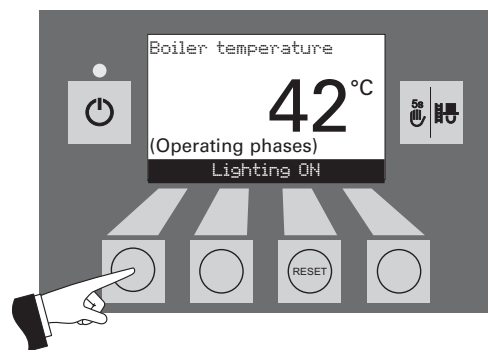

Fig. 52

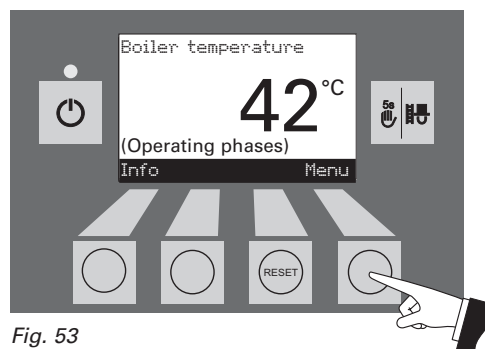

Fig. 53



Fig. 54

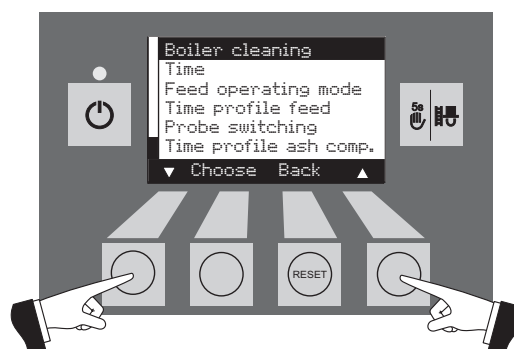

Fig. 55

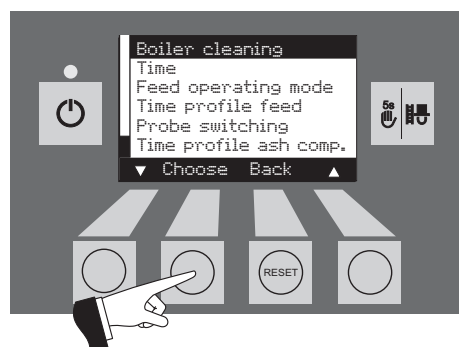

Fig. 56

Operation

Pressing the *Yes* button resets the boiler cleaning – Fig. 57. The display shows „Parameter is saved“ for a few seconds (Fig. 58) and then changes back to the previous level – Fig. 59.

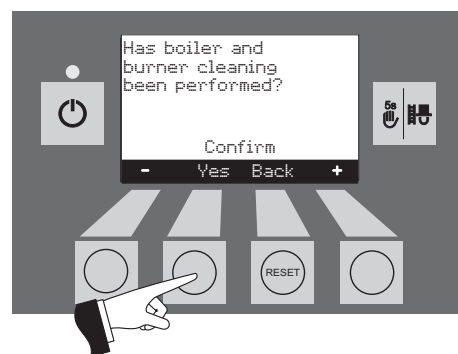

Fig. 57

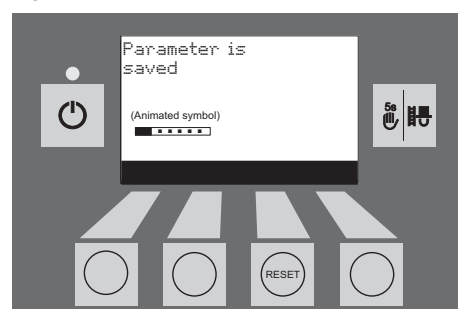

Fig. 58

The menu item or sub-menu item is exited by pressing the *Back* button (Fig. 59) or after a delay of 45 seconds.

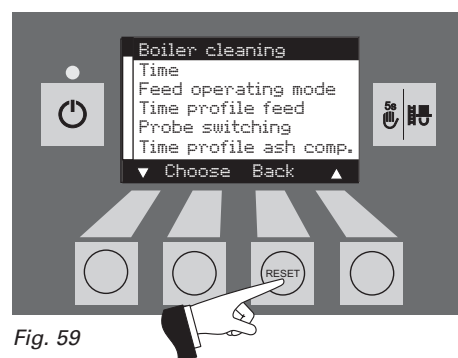

Fig. 59

Operation

2.8.1.2 Time

This time is used for the time control of the pellet feed, automatic heating surface cleaning and automatic ash compression.

Pressing one of the six buttons switches the lighting and display on – Fig. 60.

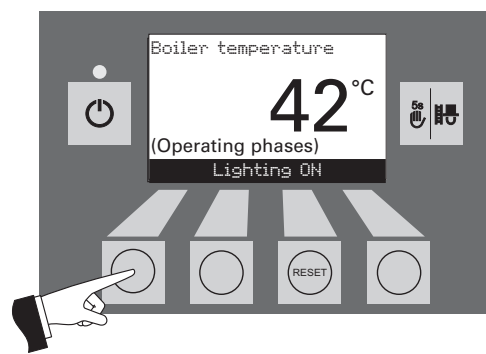

Fig. 60

Press the *Menu* button – Fig. 61.

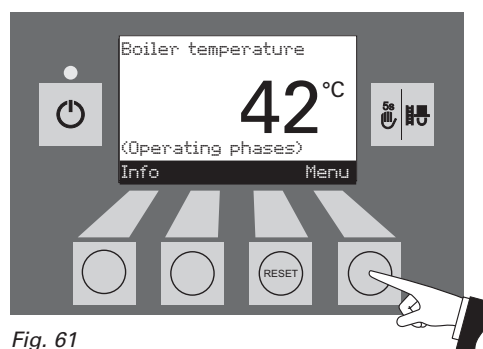

Fig. 61

Confirm the selected menu item „Operator level“ by pressing the *Choose* button – Fig. 62.



Fig. 62

Confirm the selected sub-menu item „Time“ by pressing the *Choose* button – Fig. 63.

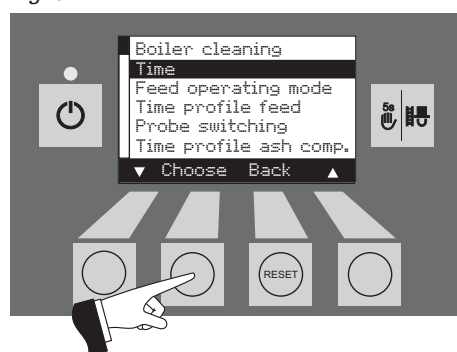

Fig. 63

Use the *arrow* buttons to set the required time – Fig. 64.

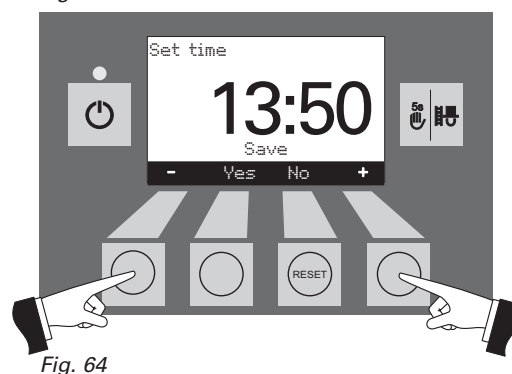

Fig. 64

Operation

Save the changed time by pressing the *Yes* button – Fig. 65. The display shows „Parameter is saved“ for a few seconds (Fig. 66) and then changes back to the previous level – Fig. 67.

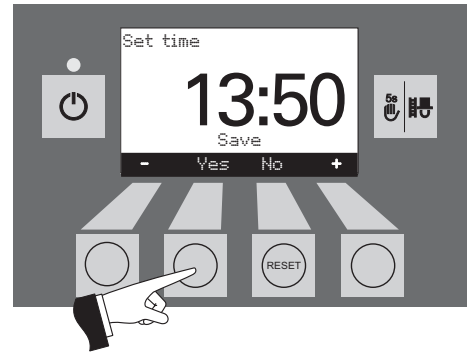

Fig. 65

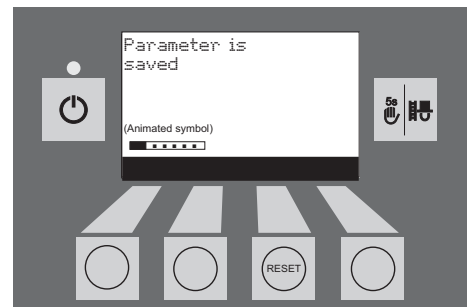

Fig. 66

The menu item or sub-menu item is exited by pressing the *Back* button (Fig. 67) or after a delay of 45 seconds.

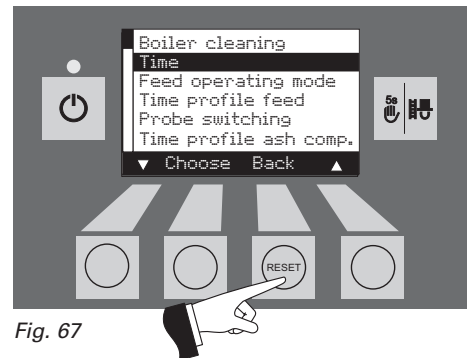

Fig. 67

Operation

2.8.1.3 Feed operating mode¹⁾

This menu item sets:

- whether the feed is switched off, or
- whether the feed should fill the pellet boiler with or without time control.

Pressing one of the six buttons switches the lighting and display on – Fig. 68.

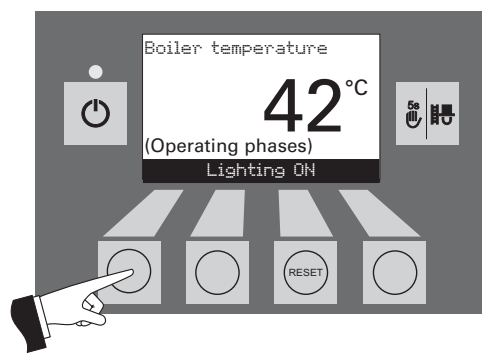

Fig. 68

Press the *Menu* button – Fig. 69.

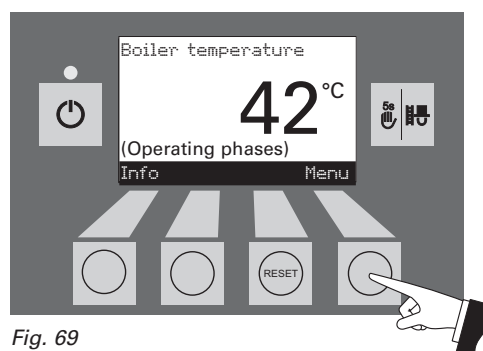

Fig. 69

Confirm the selected menu item „Operator level“ by pressing the *Choose* button – Fig. 70.

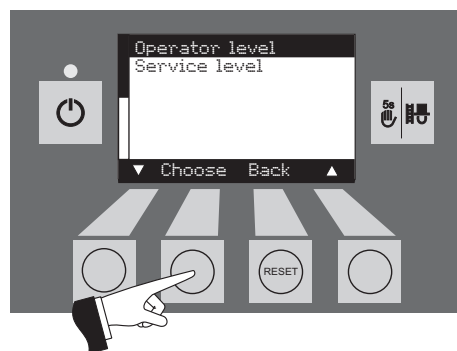

Fig. 70

Use the *arrow* buttons to select the sub-menu item „Feed operating mode“ – Fig. 71.

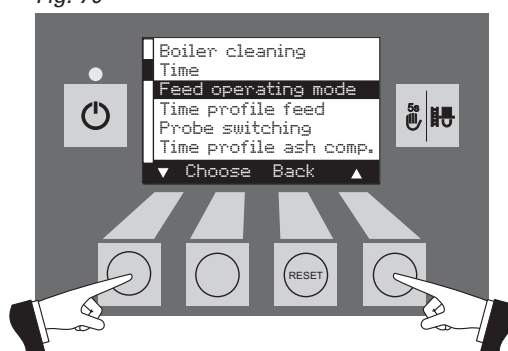

Fig. 71

Confirm the selected sub-menu item „Feed operating mode“ by pressing the *Choose* button – Fig. 72.

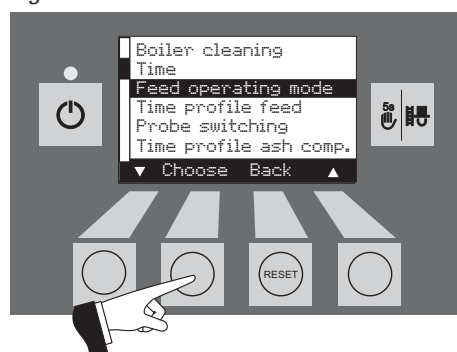

Fig. 72

¹⁾ Only displayed if a feed system is present and if this has been adjusted by a trained service technician in the service level.

Operation

2.8.2 Service level

System parameters, start-up and the actuator test can be displayed, performed and/or modified in the service level.



Changes in the Service level may be performed only by trained service personnel (directions for setting, see the BAXI Bioflo assembly instructions).

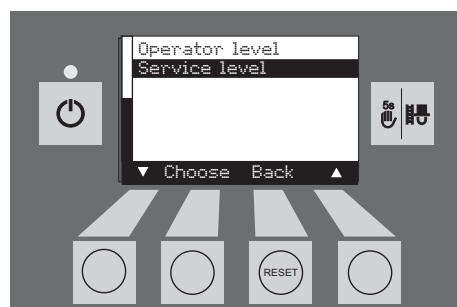

Fig. 73



Fig. 74

The menu item or sub-menu item is exited by pressing the *Back* button (Fig. 75) or after a delay of 45 seconds.

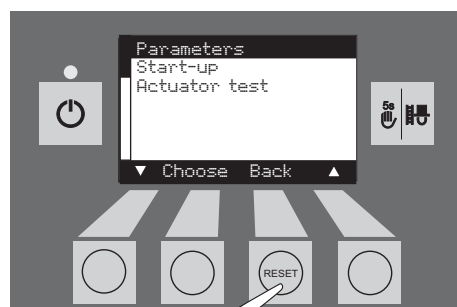





Fig. 75

2.9 Heating system operation





Operation

How to switch to manual operation





Heating emergency operation:

1. There must be power to the boiler. The unit is switched on (otherwise, press the ON/OFF button  on the Info panel unit).
2. Select „Manual operation“  |  on the Info panel unit – see section 2.5.5.
3. Set the manual switch to the „Heating manual operation“ position .
4. Also set the motorised mixing valve to manual operation and select the desired flow temperature. The boiler temperature will be maintained at the selected temperature (60 to 75 °C). **Exercise caution if you have underfloor heating.**

Manual operation of boiler reservoir with feed pump:

1. There must be power to the boiler. The unit is switched on (otherwise, press the ON/OFF button  on the Info panel unit).
2. Select „Manual operation“  |  on the Info panel unit – see section 2.5.5.
3. Set the manual switch to the „Hot water tank manual operation“ position .
4. Once the desired hot water temperature has been reached, set the manual switch to the „Hot water tank automatic operation“ position .

Manual operation of hot water tank loading with charging valve:

1. There must be power to the boiler. The unit is switched on (otherwise, press the ON/OFF button  on the Info panel unit).
2. Select „Manual operation“  |  on the Info panel unit – see section 2.5.5.
3. Set both manual switches  and  to the „Manual operation“ position.

Care, cleaning and maintenance

3.1 Care of the front window, cladding and keyboard foil

The front window is equipped with a special back ventilation. This ensures that the window remains clean for a relatively long time. Nevertheless, light deposits formed by ash constituents will form on the inside of the glass window (inside window). This causes the viewing window to be obscured. This obscuring has **no effect whatsoever on the quality of combustion**. The coating can be removed with the door open using **water and a cleaning cloth when the glass is cold**. If the glass window is very dirty, moisten the cleaning cloth and dip it in the ash first, then clean.

Tip: Position newspaper or the like to protect the floor against fly ash before opening the combustion chamber door.

Also clean the cladding and the keyboard foil with a moist cloth as needed. In the event of heavy soiling, use soapy water or diluted suds (do not use strong cleaners or sharp cleaning instruments).

3.2 Cleaning and operating implements

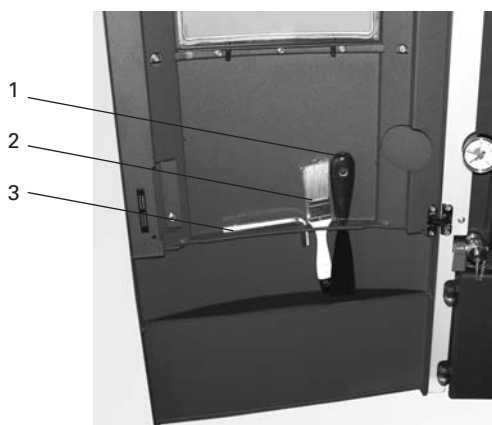

Fig. 76 Cleaning and operating implements in the cladding door

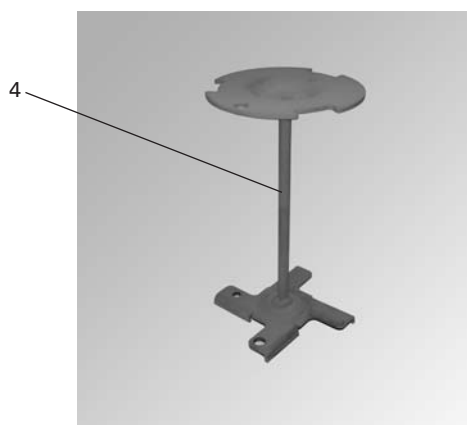

Fig. 77 Cleaning tool or removal device for cone

- 1Spatula
- 2Cleaning brush
- 3Allen key for cleaning heating surfaces
- 4Cleaning tool or removal device for cone

3.3 Overview of intervals between maintenance

A clean boiler saves fuel and protects the environment. Fly ash and combustion residues must be cleaned off the pellet central heating boiler for living areas at regular intervals. Therefore always clean your boiler as required!

Annual maintenance is required in addition to cleaning. This is performed by BAXI Customer Service or the customer service PARTNERS.

The cleaning and ash removal intervals may be reduced or extended depending on the pellets used (e.g. ash proportion), the power consumed by the heating system (frequently switching on and off).

The BAXI Bioflo is equipped with a cleaning interval display. The cleaning request for the combustion chamber and burner pot is displayed on the Info panel and must be reset after cleaning is finished – see section 2.8.1.6.

Care, cleaning and maintenance

Care, cleaning and ash removal intervals	BAXI Bioflo
<p>Depending on pellet consumption Approx. every 37 kg (~ 20 operating hours)</p>	<p>Add pellets to reserve supply container</p>
<p>Depending on pellet consumption Approx. every 400 kg (~ 250 operating hours)</p>	<p>Empty the ash pan(s) Operate the heating surface cleaning lever Frequent use of the lever increases efficiency</p>
<p>Display <i>"Clean boiler and burner"</i> IN 580 FE 390</p>	<p>Clean combustion chamber and burner pot Empty the ash pan(s) Operate the heating surface cleaning lever Frequent use of the lever increases efficiency</p>
<p>At least once per heating season</p>	<p>Clean the top heating surfaces and linkage Clean blower wheel and blower box Clean exhaust pipe to flue Check the reserve supply container, if necessary remove dust</p>

Care, cleaning and maintenance

3.4 Heating surfaces

Optimum efficiency is achieved when the heating surfaces are cleaned as often as possible using the cleaning lever. However, the cleaning lever should be connected on the right side and moved backwards and forwards several times at the latest **before** the ash pan is removed or the ash removed from the heating surfaces — Fig. 78.



Fig. 78 Connect the lever and operate it

3.5 Ash pan, ash on heating surface



Always switch the boiler off first with the ON/OFF button (Fig. 79) and wait until burnout mode has finished. Do not open the combustion chamber and ash door during operation.

Tip: Position newspaper or the like to protect the floor against fly ash before opening the combustion chamber door.

- Open the cladding door and ash door, empty the ash pan under the combustion chamber and the ash pan for the heating surfaces (accessory) or remove the ash from the duct – Fig 80.

Assembly:

- Push in the ash pan(s), close the doors.
- Switch the BAXI Bioflo back on with the ON/OFF button.



Fig. 79 Switching off BAXI Bioflo



Ash pan for heating surfaces (accessories)

Fig. 80 Empty the ash pan(s) or remove the ash from the heating surface duct



When emptying the ash pan(s), remember that there could still be embers in the ash!

Care, cleaning and maintenance

3.6 Combustion chamber

The BAXI Bioflo is equipped with a cleaning interval display. The cleaning request for the combustion chamber and burner pot is displayed on the info panel after 500 operating hours, and must be reset after cleaning has finished – see section 2.8.1.6. „Boiler cleaning – Resetting the cleaning request“.



Do not open the combustion chamber door during operation. Always switch the boiler off first with the ON/OFF button (Fig. 81) and wait until burnout mode has finished. It is essential to let the boiler cool down before cleaning.

3.6.1 Baffle plate, thermocontrol sensor

- Open the combustion chamber door, lift the baffle plate at the right and guide it out at an angle, sloping down to the left – Fig. 82, Removing the baffle plate and fly ash.
- If necessary, remove fly ash from the thermocontrol sensor with a cleaning brush. The thermocontrol sensor is located at the top left of the combustion chamber behind the baffle plate – Fig. 83.

Assembly:

By working through these steps in reverse order.



Fig. 81 Switching off BAXI Bioflo



Fig. 82 Removing and cleaning the baffle plate





Thermocontrol sensor

Fig. 83 Cleaning the thermocontrol sensor (with cleaning brush)

Care, cleaning and maintenance

3.6.2 Burner pot

 Do not open the combustion chamber door during operation. Always switch the boiler off first with the ON/OFF button and wait until burnout mode has finished. It is essential to let the boiler cool down before cleaning.

 Before cleaning with a vacuum cleaner, check that there are no longer any embers in the combustion residue!

Clean the burner pot once the secondary air holes or the holes in the primary air pin are partly blocked or the unit prompts you to clean the burner pot with a fault message.

 The glow ignition is located in the primary air tube so avoid shaking the burner pot violently – risk of breakage!

- Lift out the cone (3) using the cleaning tool (1) – Fig. 84.
- Use the spatula to scrape off the deposits from all sides of the cone (3), but particularly on the underside.
- Vacuum out the burner pot, remove the primary air pin (4) and carefully clean the holes with a small screwdriver or drill bit if necessary (holes must be clear).
- Lift out and remove the grate plate (5) from below through the base of the burner pot. Scrape off ash residues from the grate plate (5) and from the hole in the middle using the spatula to clean it.
Tip: Dampen stubborn residue with water before scraping off.
- Scrape combustion residue off the burner pot base by turning the cleaning tool (1) – Fig. 84. The pipe for the primary air pin serves as a guide for the cleaning tool – see detail. Use the spatula to scrape the edges of the burner pot base clean. All secondary air holes (6) must be clear - clean them with a small screwdriver or drill bit if necessary.
- Remove combustion residue from the burner pot with a vacuum cleaner. Vacuum the ash out of the primary air tube (in the middle of the burner pot).

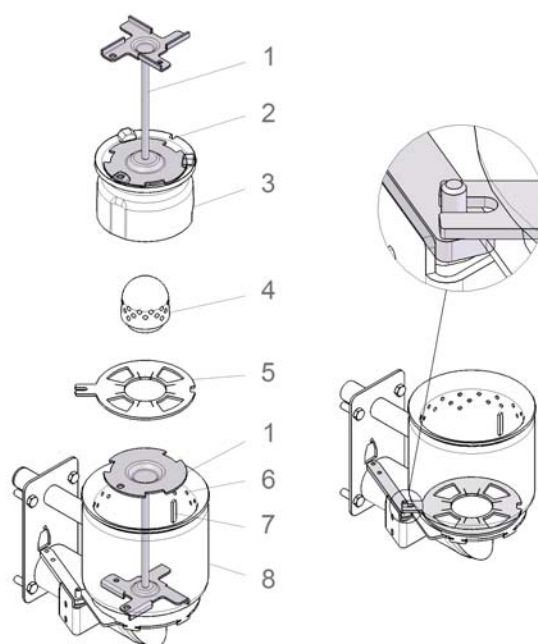
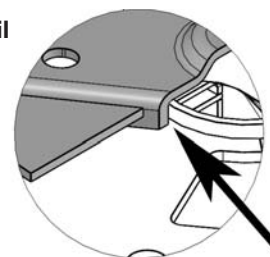

Fig. 84

Fig. 85

- 1 Cleaning tool or removal device for cone
- 2 Guide groove for locking the cone in the burner pot
- 3 Cone
- 4 Primary air pin
- 5 Grate plate
- 6 Secondary air holes
- 7 Lock for cone
- 8 Burner pot

Detail



Assembly:

- Insert the grate plate (5), making sure the projection/opening of the grate plate (5) projects through the driver of the driving rod and rests fully on the bottom grate plate – Fig. 85.
Important: Before inserting the primary air pin (4), once again vacuum out the primary air tube in the middle of the burner pot. Make sure there is no debris in the tube (to avoid damage to the ignition element!).
- Insert the primary air pin (4) (groove must engage with anti-twist device).
- Place the cone (3) into the burner pot using the cleaning tool (1). The guide groove (2) on the cone must engage with the lock (7) – Fig. 84.
- **Note:** After cleaning, the cleaning request for the combustion chamber and burner pot is reset on the Info panel – see Section 2.8.1.1.

Care, cleaning and maintenance

3.7 BAXI Bioflo reserve supply container

It is necessary to clean the reserve supply container if too much dust has collected on the sides or at the opening above the auger, or there are foreign bodies in the reserve supply container. In order to be able to check this, there must not be any pellets in the reserve supply container. Therefore, allow the pellets in the reserve supply container to be consumed or, in the case of BAXI Bioflo with automated feed, switch off the feed on the day before (see section 2.8.1.3 Setting the feed operating mode).

Cleaning

- Switch off the BAXI Bioflo with the ON/OFF button on the Info panel (Fig. 86) and wait until the display has gone out.
- **Close the glass cover – danger of damage** – Fold open the cover of the reserve supply container (Fig. 87) and vacuum out the pellets, dust or foreign bodies through the mesh using a vacuum cleaner.



Fig. 86 Switching off BAXI Bioflo



Fig. 87 Folding open the cover

Care, cleaning and maintenance

3.8 Top heating surfaces and linkage

These parts are automatically checked and cleaned as part of the annual maintenance by heatteam, the service division of BAXI Group

 Always switch the boiler off first with the ON/OFF button (Fig. 88) and wait until burnout mode has finished. It is essential to let the boiler cool down before cleaning.

- Remove the front cover (tip: open the cover of the reserve supply container first) – Fig. 89.



Fig. 88 Switching off FireWIN



Fig. 89 Removing the cover

- Unscrew two wing nuts from the heating surface cover and remove the complete cover – Fig. 90.
- Remove the jet protection plate (tip: vacuum out fly ash first using a vacuum cleaner) – Fig. 91.



Fig. 90 Removing the wing nuts and cover



Fig. 91 Removing the jet protection plate

- Vacuum down the top heating surfaces and linkage or clean with a cleaning brush – Fig. 92.
- Push on the cleaning lever of the heating surfaces at the right side and move it forwards and backwards several times — Fig. 93



Fig. 92 Cleaning top heating surfaces and linkage



Fig. 93 Connecting the lever and operating it several times

- Empty the ash pan for the heating surfaces (accessory) or remove the ash from the duct – Fig. 94.



Fig. 94 Removing the ash pan(s) or removing the ash

Care, cleaning and maintenance

3.9 Pressure measuring nipple, rotary feeder, blower wheel, blower box and exhaust pipe

These parts are automatically checked and cleaned as part of the annual maintenance by heatteam, the service division of Baxi Group.



It is essential to let the boiler cool down before cleaning.

- Unhook the right side panel cladding and disconnect the mains power plug over the control panel – Fig. 95
- Remove the screw under the mains power plug on the control panel (Fig. 95) and swivel open the control panel.

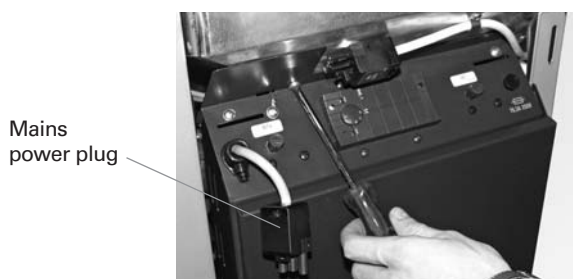

Fig. 95 Removing the power plug and screw

3.9.1 Pressure measuring nipple for combustion chamber pressure switch

The pressure measuring nipple must always be free from fly ash so that the combustion chamber pressure can be monitored.

Cleaning:

- Pull the pressure hose off the pressure measuring nipple (Fig. 96) and clean the induction opening in the pressure measuring nipple, e.g. using a small screwdriver, drill bit or the like – Fig. 97.
- Push the pressure hose back onto the measuring nipple.

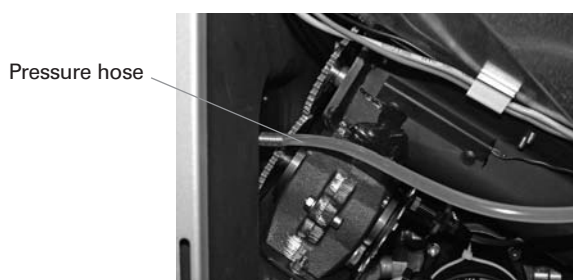

Fig. 96 Pulling off the pressure hose

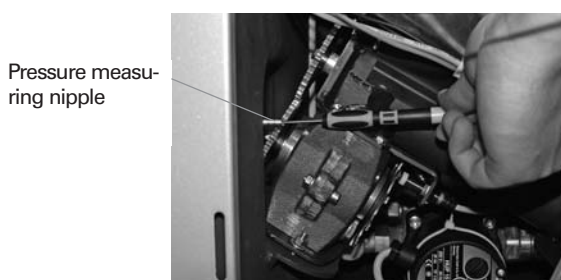

Fig. 97 Cleaning the induction opening with a small screwdriver or the like

3.9.2 Rotary feeder

Cleaning:

- Unscrew the screw plug (WAF 22) from the rotary feeder (Fig. 98) and vacuum pellet dust out of the rotary feeder using a vacuum cleaner.
- Screw the screw plug back in.

Care, cleaning and maintenance

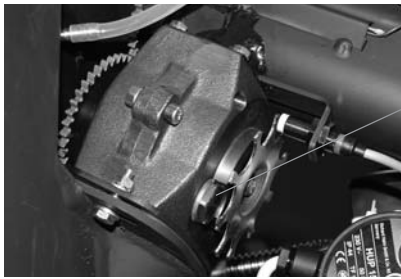

Screw plug

Fig. 98 Removing dust from the rotary feeder

3.9.3 Blower wheel, blower box and exhaust pipe to flue

- Unscrew two wing nuts from the exhaust pipe and remove the cleaning cover (Fig. 99). Clean fly ash out of the exhaust pipe with a vacuum cleaner. Close the cleaning cover again.
- Disconnect the blower plug – Fig. 100.

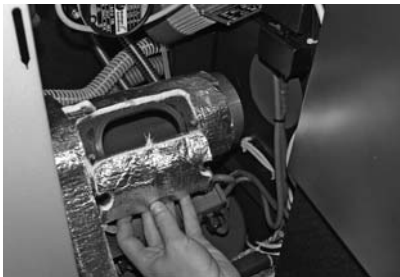

Fig. 99 Removing the wing nuts and cleaning opening – cleaning the exhaust pipe



Fig. 100 Disconnecting the blower plug

- Unscrew two wing nuts from the blower box and remove the complete blower unit – Fig. 101.
- Clean the blower wheel using a spatula and brush – Fig. 102.
- Inside of blower box: Clean fly ash with a vacuum cleaner.



Fig. 101 Removing wing nuts, removing the blower unit



Fig. 102 Cleaning the blower wheel

Assembly:

- Guide the blower unit in at the back using the stay bolts and attach at the front with two wing nuts.
- Reconnect the blower plug.
- Close the control panel, connect the securing mechanism and mains power plug at the top using a screw and hook in the side panel.

Troubleshooting

The BAXI Bioflo pellet boiler is self-monitoring during operation. All deviations from normal operation are displayed on the Info panel by information, fault or alarm messages. If one of these messages appears, the LED lights up red, an information, fault or alarm symbol flashes, and an information code is displayed along with a brief description in full text – Fig. 103.

Pressing the *Info* button (Fig. 103) displays the related information text (Fig. 104). To exit the information text menu, press the *Back* button (Fig. 104) or wait 10 seconds and the information, fault or alarm message is displayed again – Fig. 103

With almost all messages, it is necessary to press the *Reset* button after rectifying the cause of the information, fault or alarm message. In these cases, „Reset“ is displayed in the menu line – Fig. 103.

If „Reset“ is not displayed in the menu line, the boiler starts operating again automatically after the cause of the information, fault or alarm message has been rectified.

Pressing the *Test* button changes to the actuator test immediately – Fig. 105. This function is only intended for trained service personnel (for setting instructions, see the BAXI Bioflo assembly instructions). Pressing the *Back* button (Fig. 106) exits the actuator test.

 All safety functions are deactivated during the actuator test!

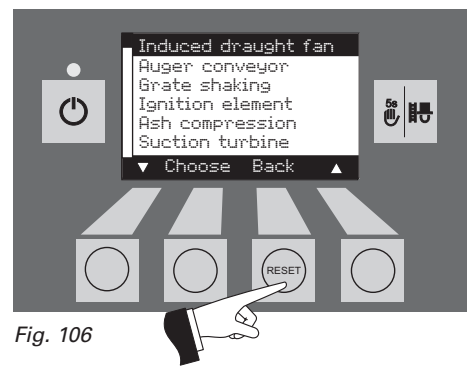
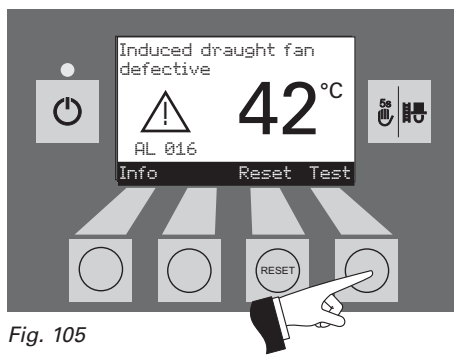
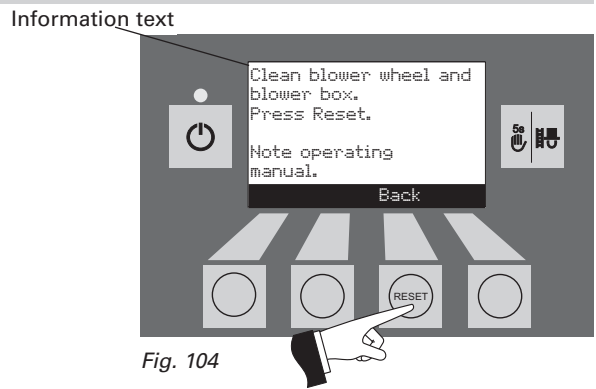
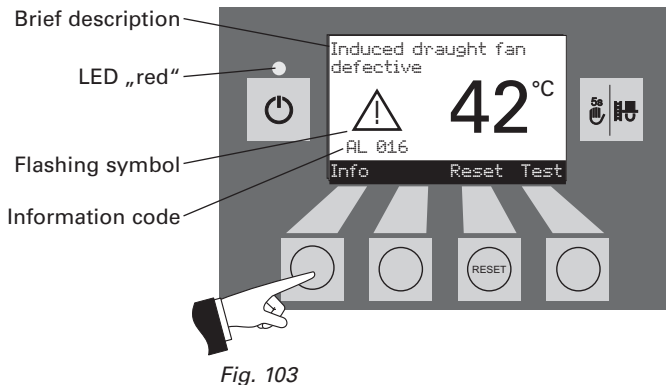

If you wish to call BAXI Customer Service or your customer service PARTNER due to a malfunction, please first make a note of the following data from the rating plate:

- Model
- Factory number
- Year of manufacture

The rating plate is located behind the cladding door between the combustion chamber door and the ash door – Fig. 107

Rating plate



Troubleshooting

4.1 No display on Info panel

Code	Meaning/effect	Cause/remedy
-	<p>No display</p> <p>Boiler is off, cannot be switched on with the ON/OFF button.</p>	<p>a) No electricity, check the cable to the device and the building fuse.</p> <p>b) No electricity, device fuse defective – check and replace if necessary – see page 56, Fig. 109.</p> <p>c) Info panel plug loose or poorly connected together if connected at all during installation – check and connect together firmly if necessary, plug is located on the side at the top behind the right side panel cladding – see installation instructions; Installing the cladding.</p>

4.2 Information messages

Code	Meaning/effect	Cause/remedy
IN 581	<p>Replenish fuel</p> <p>The reserve supply container is almost empty. Top up pellets.</p>	Fill fuel into the fuel container (see section 2.3).
IN 582	<p>Reserve supply container empty</p> <p>The reserve supply container is empty. Top up pellets. Burner is locked.</p>	Fill fuel into the fuel container (see section 2.3).
IN 590	<p>Clean boiler and burner</p> <p>Perform cleaning and confirm in operator level.</p>	<p>Boiler and burner are still operating.</p> <p>Boiler and burner must be cleaned or the <u>both</u> ash pan(s) (see Fig. 162) emptied (see sections 3.4, 3.5 and 3.6). Following cleaning, confirm cleaning on the Info panel operator level (see section 2.8.1.1).</p>
IN 595	<p>Door open</p> <p>Burner locked. Only open the door when the burner is switched off.</p>	<p>Cladding door is open, burner locked.</p> <p>a) Close the cladding door.</p> <p>b) Door switch on cladding door does not switch correctly, adjust – see installation instructions.</p>

Troubleshooting

4.3 Fault messages

Code	Meaning/effect	Cause/remedy
FE 206	Monitoring of the auger conveyor is defective Press Reset.	The boiler is in operation. Press the Reset button. If the fault reoccurs after a reset, inform BAXI Customer Service or a heating technician.
FE 356	Combustion chamber pressure not stable Press Reset.	The boiler is in operation. a) Heating surface cover leaking, check whether this is firmly closed (see section 3.8), press the Reset button. b) Combustion chamber and ash door are leaking – check the seal, replace the seal if necessary, press the reset button. c) Pressure measuring nipple of combustion chamber pressure switch is blocked – clear it (see section 3.9.1), press the reset button. d) Intake air line or induction opening at rear is blocked – clear it and press the reset button. e) Exhaust pipe or flue is blocked, clear it and press the reset button. f) Combustion chamber pressure switch is defective, inform BAXI Customer Service or a heating technician.

Troubleshooting

Code	Meaning/effect	Cause/remedy
FE 382	<p>Fill level switch in reserve supply container defective</p> <p>Check the switch in the reserve supply container. Press Reset.</p>	<p>The boiler does not operate.</p> <p>a) Fill level switch (proximity switch) dirty, remove the dust (see section 3.7), press the Reset button.</p> <p>b) Fill level switch (proximity switch) in the reserve supply container defective – inform BAXI Customer Service or a heating technician.</p>
FE 390	<p>Emergency operation! Clean boiler and burner</p> <p>Perform cleaning and confirm in operator level.</p>	<p>The boiler is in cyclic operation, i.e. has idle times.</p> <p>a) Boiler and burner must be cleaned or the <u>both</u> ash pan(s) (see Fig. 108) emptied (see sections 3.4, 3.5 and 3.6). Following cleaning, confirm cleaning on the Info panel operator level (see section 2.8.1.1).</p> <p>b) Motor or limit switch of ash compactor defective, inform BAXI Customer Service or a heating technician.</p>

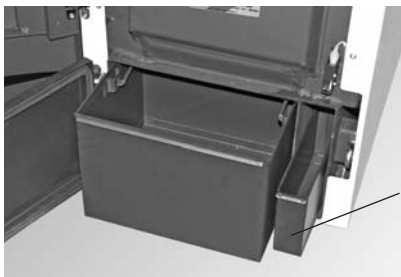

Ash pan for heating surfaces (accessories)

Fig. 108 Empty the ash pan(s) or remove the ash from the heating surface duct

4.4 Alarm messages

Code	Meaning/effect	Cause/remedy
AL 005	<p>Shake-out defective</p> <p>Shake-out defective or sticking. Clean the burner pot. Press Reset.</p>	<p>Shake-out motor no longer moves or no longer reaches the end position, boiler switches to burnout mode.</p> <p>a) Burner contamination; close combustion chamber doors, press reset button; once the alarm message is rectified, clean the burner pot as described in section 3.6.</p> <div style="border: 1px solid black; padding: 5px; margin: 10px 0;">  <p>The glow ignition is located in the primary air tube so avoid shaking the burner pot violently – risk of breakage!</p> </div> <p>If the alarm message remains active, clean the burner pot as described in section 3.6. <u>Note:</u> Grate plate at top can only be raised and removed when closed. If the grate plate is not fully closed, vacuum it out. Close combustion chamber door, press reset button, if the alarm message remains in place, repeat the process or inform Baxi Customer Service or a heating technician.</p> <p>b) Grate plate not inserted correctly or check correct installation position (see section 3.6).</p> <p>c) Motor for shake-out defective, inform BAXI Customer Service or a heating technician.</p> <p>d) Limit switch defective, inform BAXI Customer Service or a heating technician.</p>

Troubleshooting

Code	Meaning/effect	Cause/remedy
AL 006	<p>Auger conveyor motor defective</p> <p>Auger conveyor motor defective. Press Reset.</p>	<p>Boiler enters burnout mode, vacuum fan is stopped immediately.</p> <p>a) Auger conveyor or rotary feeder jammed due to a foreign body, clean the reserve supply container, opening above auger conveyor or rotary feeder (see section 3.9) and remove the foreign body. Press the Reset button. The alarm message AL 171 may light on up to 2 occasions until the boiler starts operating again, press the Reset button.</p> <p>b) Control thermostat defective, inform Baxi Customer Service or a heating technician.</p> <p>c) Press the Reset button. If the malfunction recurs immediately after a short period, or recurs at regular intervals, contact Baxi Customer Service or your heating technician.</p> <p>d) Renew the auger conveyor motor, inform Baxi Customer Service or a heating technician.</p>
AL 016	<p>Vacuum fan defective</p> <p>Clean blower wheel and blower box. Press Reset.</p>	<p>The actual speed is different from the nominal speed. The boiler switches to burnout mode.</p> <p>a) The blower wheel and blower box are dirty, press the Reset button. If the malfunction recurs immediately after a short period, or recurs at regular intervals, contact Baxi Customer Service or your heating technician.</p> <p>b) Replace the vacuum fan motor, inform Baxi Customer Service or a heating technician.</p>
AL 062	<p>Air intake/exhaust flap defective</p> <p>Air intake/exhaust flap defective or not opening. Check flap. Press Reset.</p>	<p>External air choke (optional) does not open.</p> <p>a) Check the air choke, press the Reset button.</p> <p>b) Inform Baxi Customer Service or a heating technician.</p>
AL 071	<p>Safety / emergency switch open</p> <p>Check switch position of safety / emergency switches.</p>	<p>Boiler enters burnout mode but the blower does not run.</p> <p>Switch on emergency heating/OFF switch.</p>
AL 076	<p>Boiler sensor defective</p> <p>Check the boiler sensor and connections. Press Reset.</p>	<p>The boiler switches to burnout mode.</p> <p>a) Press the Reset button. If the malfunction recurs immediately after a short period, or recurs at regular intervals, contact Baxi Customer Service or your heating technician.</p> <p>b) Replace the boiler sensor, inform Baxi Customer Service or a heating technician.</p>
AL 078	<p>Thermocontrol sensor defective</p> <p>Check the thermocontrol sensor and connections. Press Reset.</p>	<p>The boiler switches to burnout mode.</p> <p>a) Thermocontrol sensor is too cold < 0 °C. Sensor warm up.</p> <p>b) Press the Reset button. If the malfunction recurs immediately after a short period, or recurs at regular intervals, contact Baxi Customer Service or your heating technician.</p> <p>c) Replace the thermocontrol sensor, inform Baxi Customer Service or a heating technician.</p>

Troubleshooting

Code	Meaning/effect	Cause/remedy
AL128	<p>No flame formation in control mode</p> <p>Clean boiler and burner. Press Reset.</p>	<p>The flame goes out in modulation mode. The boiler switches to burnout mode.</p> <p>a) Clean the burner and the boiler. Check the exhaust pipe to the flue and clean it if necessary, press the Reset button.</p> <p>b) Auger conveyor or rotary feeder jammed due to a foreign body. Clean the reserve supply container, opening above auger conveyor or rotary feeder (see section 3.7) and remove the foreign body. Press the Reset button. The alarm message AL 171 may light on up to 2 occasions until the boiler starts operating again, press the Reset button.</p> <p>c) Inform Baxi Customer Service or a heating technician.</p>
AL 133	<p>Safety temperature shut-down</p> <p>Check the system and filling pressure. Press Release button on boiler.</p>	<p>Boiler temperature is above 100 °C, boiler enters burnout mode, vacuum fan is switched off immediately.</p> <p>a) Check the water level or pressure in the heating system – refill, bleed the air.</p> <p>b) Air in the heating system – bleed air.</p> <p>c) The heat pump or boiler feed pump is sticking or is defective – start pump manually or have it repaired.</p> <p>Once the boiler water temperature falls below 90 °C, remove the cover, press the Release button of the safety thermostat B7 firmly – Fig. 163.</p> <p>If the malfunction occurs after a short period, or recurs at regular intervals, contact Baxi Customer Service or your heating technician.</p>
AL 135	<p>Excess temperature in the auger tube</p> <p>Check the burner. Press Release button B7a on control panel.</p>	<p>The boiler switches to burnout mode.</p> <p>a) Check the burner, remove all pellets from the burner pot.</p> <p>b) Remove the cover from the safety thermostat auger tube B7a, press the Release button firmly (see Fig. 163). If the ignition does not function first time (AL 171), press the Reset button (pellets in the auger conveyor will have been damaged due to the higher temperature).</p>



Fig. 109 FireWIN control panel, rear right side panel removed

Troubleshooting

Code	Meaning/effect	Cause/remedy
AL 156	<p>No negativ pressure in combustion chamber or sensor defective.</p> <p>Press Reset.</p>	<p>The boiler switches to burnout mode.</p> <p>a) Heating surface cover leaking, check whether this is firmly closed (see section 3.8), press the Reset button.</p> <p>b) Combustion chamber and ash door are leaking – check the seal, replace the seal if necessary, press the reset button.</p> <p>c) Pressure measuring nipple of combustion chamber pressure switch is blocked – clear it (see section 3.9.1), press the reset button.</p> <p>d) Intake air line or induction opening at rear is blocked – clear it and press the reset button.</p> <p>e) Exhaust pipe or flue is blocked, clear it and press the reset button.</p> <p>f) Combustion chamber pressure switch is defective, inform Baxi Customer Service or a heating technician.</p>
AL 171	<p>Maximum heating up time exceeded</p> <p>Clean the burner pot. Press Reset.</p>	<p>a) The reserve supply container is empty. Fill fuel into the fuel container (see section 2.3). Press the Reset button until the boiler starts operating again. The alarm message AL 171 may light on up to 2 occasions, press the Reset button.</p> <p>b) Clean the burner pot (see section 3.6), empty the ash pan .</p> <p>c) Too much dust in the reserve supply container – bridge formation, remove the dust (see section 3.7), press the Reset button.</p> <p>d) Auger conveyor or rotary feeder jammed due to a foreign body, clean the reserve supply container or rotary feeder (see section 3.7) and remove the foreign body, refill the reserve supply container. The alarm message AL 171 may light on up to 2 occasions until the boiler starts operating again, press the Reset button.</p> <p>f) Ignition defective, inform Baxi Customer Service or a heating technician.</p>
AL 187	<p>No communication with main PCB</p> <p>Check connection for main PCB and connections. Press Reset.</p>	<p>The boiler switches to burnout mode.</p> <p>a) Check the connection cable or Info panel plug connection to the main PCB, inform Baxi Customer Service or a heating technician.</p> <p>b) Connect the main PCB, inform Baxi Customer Service or a heating technician.</p>
AL 188	<p>Internal error occurred ErrorCode 188 Current TableID 4</p>	<p>Internal communication error. The boiler switches to burnout mode.</p> <p>A reset is performed automatically after 1 minute if this error occurs.</p> <p>If the malfunction occurs after a short period, or recurs at regular intervals, contact Baxi Customer Service or your heating technician.</p>

Declaration of conformity

Please complete the boxes below

Serial Number

Date of Installation

D	D	M	M	Y	Y

Installer Details (name, address and contact number(s))

All descriptions and illustrations provided in this leaflet have been carefully prepared but we reserve the right to make changes and improvements in our products which may affect the accuracy of the information contained in this leaflet. All goods are sold subject to our standard Conditions of Sale which are available on request.

BAXI
A Trading Division of Baxi Heating UK Ltd (3879156)
Brooks House, Coventry Road, Warwick. CV34 4LL
After Sales Service & Technical Enquiries 0844 871 1568
Website www.baxi.co.uk
e&oe

PART OF BDR THERMEA

Guarantee & Warranty Limitations

The guarantee and warranty limitations require that the boiler and related accessories be properly installed, commissioned and started up by either i) heateam service engineer or ii) a HETAS approved engineer and the HETAS approved number must be logged on the supplied warranty card; otherwise the manufacturer's guarantee will not be honoured.

Malfunctions resulting from improper operation or adjustment as well as use of poor or not recommended fuel types are not covered by the guarantee and warranty. Further, the warranty shall be void if equipment other than those provided by heateam are installed. The special warranty restrictions for your system are available in the "Warranty Conditions" folder supplied with your boiler.

Start-up and regular maintenance following the terms of the "Warranty Conditions" will assure safe, environmentally friendly and economical operation of your system. We recommend that you obtain a maintenance service contract.

The Baxi Bioflo wood pellet sealed central heating system boiler includes a one year parts and labour guarantee. The labour guarantee is subject to a set up and test being completed by a Baxi Engineer or Baxi approved installer (HETAS Qualified).

Baxi offer a free set up and test with this product. Please contact Baxi on 0844 871 1568 to arrange this service.

Open Monday - Friday, 8am - 6pm
Saturdays, 8.30am - 2pm
We are closed on Christmas Day & New Year's Day

Alternatively your HETAS qualified installer must complete the enclosed set up and test checklist and warranty registration card and return to the address below

Warranty Registrations
Baxi Heating UK Ltd
Brooks House
Coventry Road
Warwick
CV34 4LL