



**Owner's Manual**



**Dogtra Company**

22912 Lockness Avenue

Torrance, CA 90501 U.S.A.

Tel) 310.534.0101

Fax) 310.534.9111

Toll free) 1.888.811.9111

Store website) [shop.dogtra.com](http://shop.dogtra.com)

Copyright © 2007 Dogtra Company All rights reserved. (4)

Remote Release Bird Launcher Systems

**dogtra** RR Deluxe

**dogtra** QL/PL



[www.dogtra.com](http://www.dogtra.com)

• OVERVIEW .....	2
• MAIN FEATURES .....	3
• PACKAGE CONTENTS .....	3
• IMPORTANT SAFEGUARDS .....	4
• DESCRIPTION OF TRANSMITTER PARTS.....	5
• DESCRIPTION OF RECEIVER PARTS .....	8
• DESCRIPTION OF LAUNCHER PARTS(QL, PL)	11
• <b>dogtra</b> QL / PL ASSEMBLY AND OPERATION ....	14
• <b>dogtra</b> QL / PL ADJUSTING SPRING STRENGTH SETTINGS .....	21
• CHARGING THE BATTERIES .....	23
• RECEPTION .....	26
• ACCESSORIES .....	27
• BASIC MAINTENANCE .....	28
• WARRANTY AND REPAIR INFORMATION	29

## OVERVIEW

### Thank you for purchasing Dogtra remote release bird launcher systems

Dogtra remote release bird launcher system is an effective tool to train your dogs to hold a point or stop to flush. With a remote release bird launcher system you can train your dogs by yourself.

Dogtra remote release bird launcher system uses a transmitter and a receiver to release the launcher from a remote location. Sound functions on the receiver can be used to train a dog or to find a launcher in heavy cover.

Dogtra remote release bird launcher System allows you to release up to 16 launchers by using left and right jack buttons and turning the transmitter selector dial to the number that corresponds with the bird launcher. Each setting will operate two launchers.

## MAIN FEATURES

**Multiple releasers** : up to 16 launchers controlled from one transmitter

**Multiple sound modes** : a receiver emits a duck call and beep sound

**Range** : effective within one mile

**Scenting** : launcher box and bird cradle are designed for maximum air flow

**Quiet launch** : prevents dogs from being startled by a loud release noise

**Waterproof** : a handheld transmitter is fully waterproof (receiver is water resistant)

**Multi colored LED** : 3 types of LED colors show the remaining battery life

## PACKAGE CONTENTS

- Transmitter and antenna
- Receiver
- Battery charger and cables
- Owner's manual

### IMPORTANT SAFEGUARDS

- DO NOT use the bird launcher until you have read this manual.
- Transport the launcher in a safe position. It should either have the bird cradle open or if it is closed, the safety pin must be inserted to lock the release latch.
- To store for long periods of time, place the bird launcher in the open position to prevent the springs from weakening.
- To avoid danger, keep the bird launcher away from children. Never leave a set bird launcher unattended. The bird cradle can pop open with significant force.
- Do not look down upon it or into it during the launch process because you may be injured as the bird cradle opens up.

#### WARNING

Use caution when using a bird launcher. Keep your head away from the top of the launcher when it is loaded. You could be injured if the dummy or bird is accidentally launched.

### DESCRIPTION OF TRANSMITTER PARTS

#### *dogtra* RR Deluxe Transmitter

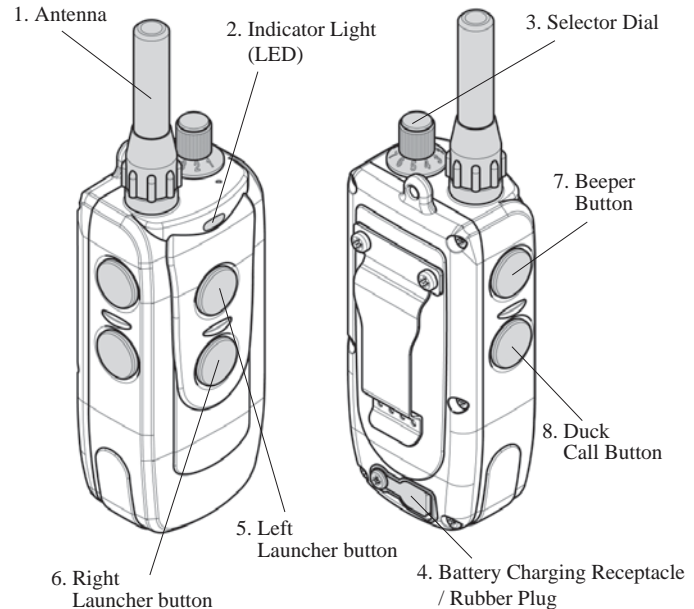

- 1. Antenna** : A 2" Antenna is supplied with Dogtra RR Deluxe transmitter. The antenna must be fastened to the transmitter before using the unit.
- 2. Indicator light(LED)** : The color of the light indicates the status of battery life. (Green = full, Amber = medium, Red = needs charge) The indicator light glows when buttons are pressed as well.
- 3. Selector dial** : By turning the selector dial you can control the desired launchers (one to eight).
- 4. Battery charging receptacle / rubber plug** : Plug the charger cable jack into this receptacle when charging the collar. After charging, make sure the rubber cover is fully seated so that dirt will not enter the receptacle.
- 5. Left launcher button** : Left launcher button releases the launcher connected to the left jack of the receiver.

- 6. Right launcher button** : Right launcher button releases the launcher connected to the right jack of the receiver.
- 7. Beeper button** : Beeper button activates the speaker horn on the receiver to emit a loud beep sound.
- 8. Duck call button** : Duck call button activates the speaker horn on the receiver to emit a series of quacks.

## DESCRIPTION OF RECEIVER PARTS

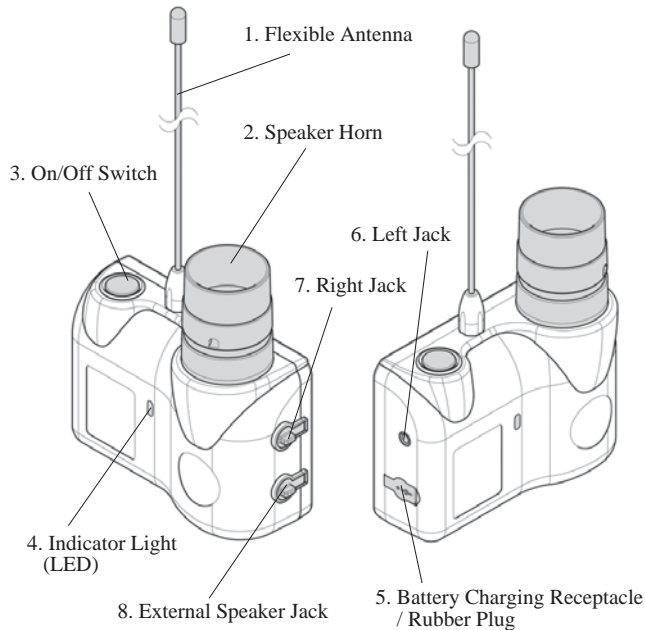
*dogtra RR Deluxe Receiver*

- 1. Flexible antenna** : Flexible antenna is located on the top of the receiver. Please do not bend the antenna forcibly for it can cause serious reduction in range.
- 2. Speaker horn** : Sound horn emits loud beep tone or quacking sound when you press “beeper” or “duck call” button.
- 3. On/off switch** : Press on/off switch to turn on and off the power.
- 4. Indicator light(LED)** : The color of the light indicates the status of battery life. (Green = full, Amber = medium, Red = needs charge) The indicator light glows when buttons from a transmitter are pressed as well.
- 5. Battery charging receptacle / rubber plug** : Plug the charger cable jack into this receptacle when charging the collar. After

charging, make sure the rubber cover is fully seated so that dirt will not enter the receptacle.

- 6. Left jack** : Jack located on the left side where a launcher can be plugged.
- 7. Right jack** : Jack located on the right side where another launcher can be plugged.
- 8. External speaker jack** : Jack for an external loud peaker, which can be purchased separately

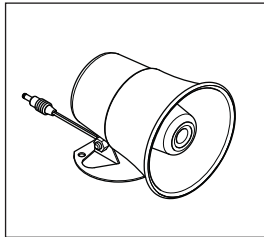

External loud speaker (sold separately)

### DESCRIPTION OF LAUNCHER PARTS (QL, PL)

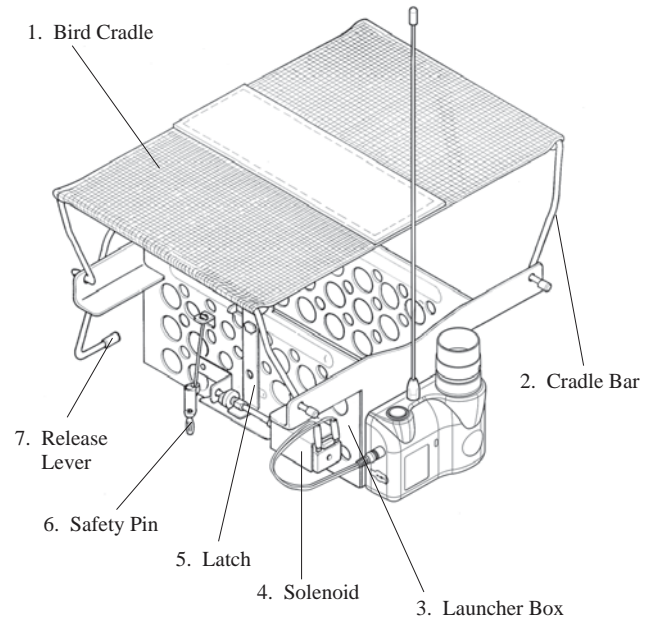

**Launcher size**

***dogtra QL*** (Launcher) - for quail

- 8.6" × 4.5" × 4.3"
- Excellent choice for quail and pigeons

***dogtra PL*** (Launcher) - for pheasant

- 13.2" × 6.9" × 6.9"
- Handles large birds with ease

- 1. Bird cradle** : Bird cradle holds a dummy or bird for launching.
- 2. Cradle bar** : Cradle bar supports a bird cradle.
- 3. Launcher box** : Launcher box contains large holes for maximum air flow and scenting possibilities.
- 4. Solenoid** : Solenoid activates the launcher by pulling the latch when the launcher button is pressed.
- 5. Latch** : Latch holds the bird cradle closed when it is set for launch.
- 6. Safety pin** : Insert safety pin to the hole in the latch to prevent the bird launcher launching accidentally.
- 7. Release lever** : Release lever holds bird cradle when it is set for launch



## *dogtra* QL, PL ASSEMBLY AND OPERATION

### Assembly

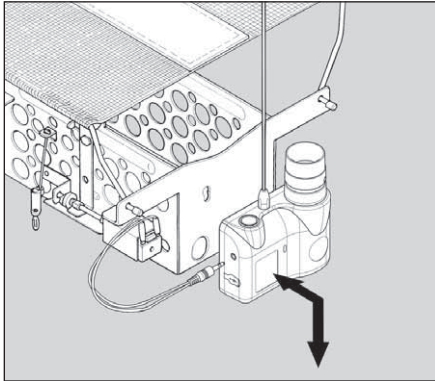

Figure 1. Mounting the receiver

- 1) To mount the receiver, attach the receiver to the launcher box and push down gently so that it locks in place. Check to see whether receiver is attached securely by pulling on the receiver.

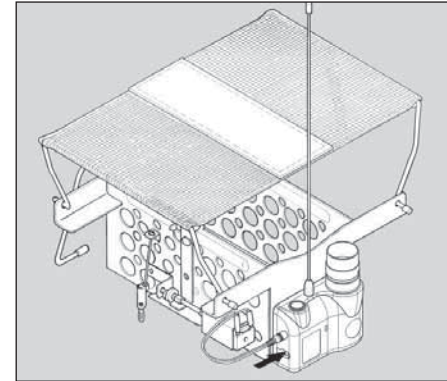

Figure 2. Plugging solenoid cord into the receiver.

- 2) Plug the solenoid cord into the receiver's left jack

### Assembly for two launchers

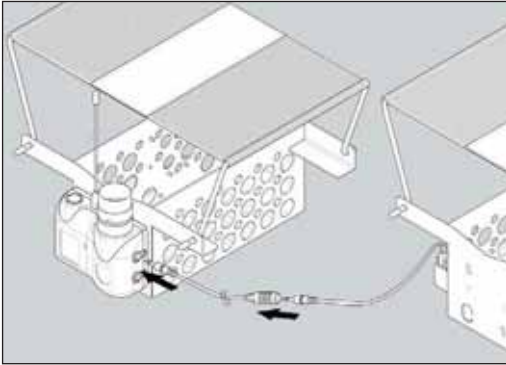

Figure 3. Assembling two launchers in one receiver

- 1) Mount the receiver to the launcher.
- 2) Plug the solenoid cord into receiver's right jack.  
**(A 15 feet extension cable can be purchased separately)**

### How to launch the Dogtra remote release bird launchers

- First, test the launcher without any dummy or bird inside.

#### **WARNING**

Keep your head away from the top of the launcher when it is loaded. You could be injured if the dummy or bird is launched accidentally.

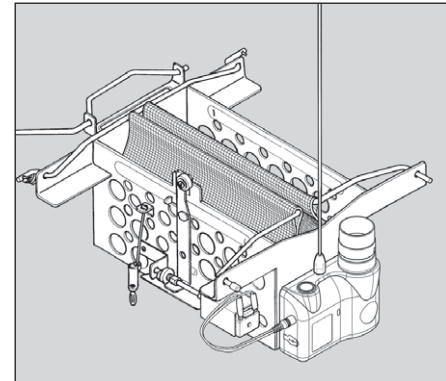

Figure 4. Closing the launcher.

- 1) Close the bird cradle inside the launcher box and hold it in place.

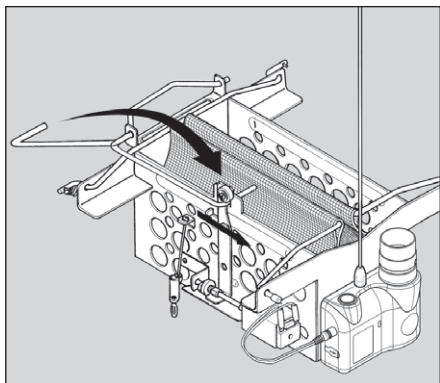

Figure 5. Setting the latch.

- 2) Place the release lever under the latch roller bearing.
- 3) Turn the receiver on. Make sure that the safety pin has been pulled out.

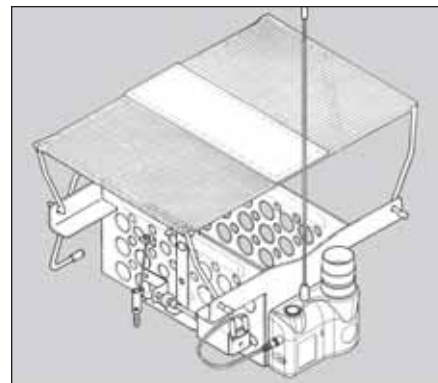

Figure 6. Remote launcher released.

- 4) Press the transmitter's left or right launcher button depending on which jack (left or right) it's connected to. The remote launcher is working properly if the bird cradle pops open like the diagram above.
- 5) Press the transmitter's beeper button or duck call button. You'll know it's working properly if the receiver sound horn emits a loud beep or quacking sound.

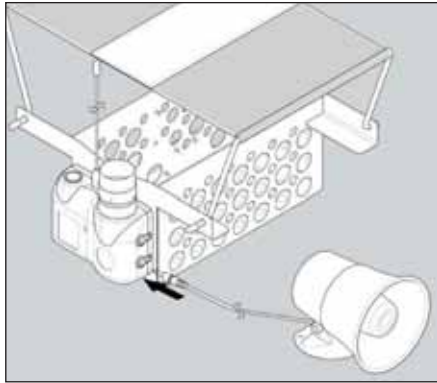

Figure 7. Using the external loud speaker (optional)

- 6) Plug the external speaker cable to the external speaker jack located on the bottom right side of a receiver. External speaker can be purchased separately.
- 7) Press the transmitter's beeper button or duck call button. The external speaker should emit a loud beep or quack sound.

## *dogtrà* QL, PL ADJUSTING SPRING STRENGTH SETTINGS

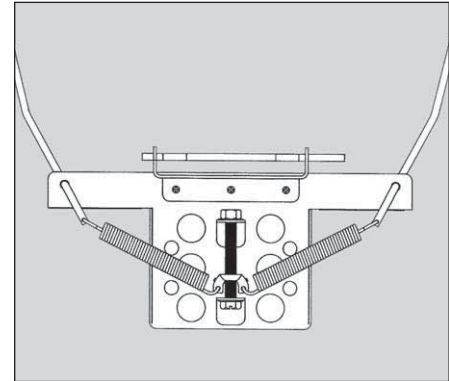

Figure 8. Positioned for high launch

- 1) The bird launcher is shipped with the springs adjusted in the bottom setting. This setting gives you the high launch. Turning clockwise will move the springs down for a higher launch: the very bottom being the highest.

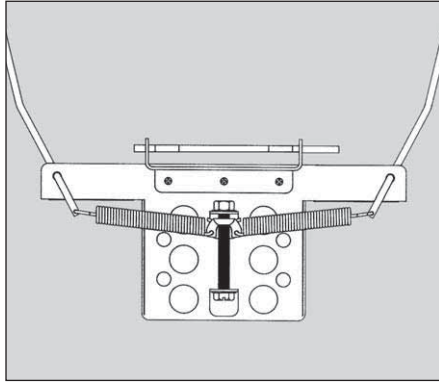
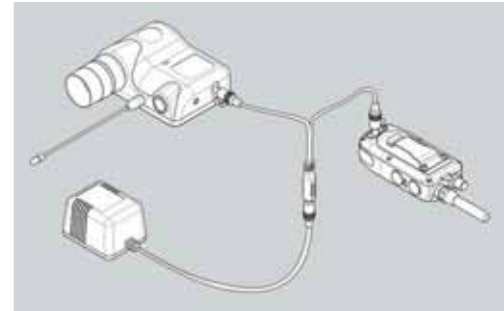

Figure 9. Positioned for low launch

- 2) Turning counter-clockwise will move the springs up for a low and quiet launch: the very top being the lowest.

## CHARGING THE BATTERIES



1. Charge the unit about 10 hours before using the unit for the first time.
2. Do not charge the batteries near any flammable substances.
3. Fully charge your units every 3 months if your units are to be stored away for more than a couple of months or longer.

### Recharge the unit if :

- The indicator light on the transmitter or receiver is emitting a red color.
- The indicator light on the transmitter or receiver will not come on.

### Battery Charging Procedure

**Note :** The unit has a partial charge when it leaves the Dogtra facility, upon receipt of the launcher systems, be sure to give it a full 10-hour initial charge before the first use.

1. Attach the charging cables to both the transmitter and receiver(s), as shown on page 23.
2. Plug the charger into a 120-volt wall outlet. (Use a 230-volt European charger for Europe.) When properly plugged in, all indicator lights should glow red. During the charging process, the unit will shut off. Once the battery cable is unplugged from the unit after a full charge, you will need to turn the unit on again before use.
3. Full charge period for the units is 10 hours. The lights will stay red during the charging process. After 10 hours, unplug the charger. Now the unit is fully charged to use.

4. After charging, cover the battery charging receptacles with the rubber plugs on the transmitter and receiver.

**NOTE : Only use Dogtra-approved batteries, chargers, and accessories for your Dogtra RR Deluxe System. When a charger is not in use, disconnect it from the power source.**

## RECEPTION

The **dogtra RR Deluxe** has a range of 1 mile. Depending on the way you use your transmitter, the transmitter range may vary.

Hold the transmitter away from your body and avoid touching the antenna, to get the greatest range.

For maximum signal strength, keep your unit properly charged.



Maximum Range



Typical Range



Minimum Range

## ACCESSORIES

The following items may be purchased separately by calling our customer service at (888) 811-9111. You may also browse the selection at [shop.dogtra.com](http://shop.dogtra.com).

### Extension Cable

A 15 foot cable allows longer distances between the receiver and the launcher.

### External Loud Speaker

Attaches to the **dogtra RR Deluxe** and gives you increase sound for windy days and extended marks (cord 4 1/2" feet long)

### Field Auto Charger

Designed for use with the 12-volt cigarette lighter in your car.

### European Charger

Designed for use with 230V AC electrical outlets in Europe.

## **BASIC MAINTENANCE**

Be sure that the rubber charging plugs are always secured when the collar is in use. If your plugs break or are ripped, please contact Customer Service at [info@dogtra.com](mailto:info@dogtra.com) or (888) 811-9111 to obtain replacements.

After each session, carefully inspect your unit for any missing parts, or casing damage. Broken casings on either the receiver or transmitter may affect the waterproof guarantee of the unit. The transmitter antenna should be secured and tight for optimum performance. Rinse the unit after each session and clean off any dirt or debris.

### **Storage Maintenance**

Your unit should be fully charged for 10 hours before extended storage. During storage, the unit should be charged every 3 months for 10 hours, and once before the first use.

When traveling, try to store your units in room or slightly warmer temperatures, do not transport the unit exposed in extreme climates.

### **Troubleshooting:**

If you have any questions or concerns, you may direct your inquiries to [info@dogtra.com](mailto:info@dogtra.com) or call (888) 811-9111.

## **WARRANTY AND REPAIR INFORMATION**

### **1-Year Comprehensive Warranty**

Dogtra Company provides the original purchaser with a 1-YEAR WARRANTY for the iQ Series, EF3000Gold, RRDeluxe, YS300, and YS500. The warranty begins from the date of purchase. For the first year, coverage is for Parts, Labor, and Accessories.

After the first year, the cost of Parts, Accessories, Labor fees, and Shipping fees incurred are the customer's responsibility. Labor fees will be variable depending on the extent of the work required.

### **To Qualify for the Dogtra Warranty**

All products must be registered and/or a proof of purchase is required to initiate repair work under warranty. To register your Dogtra product, log onto our website at [www.dogtra.com](http://www.dogtra.com), click on the warranty registration link, and fill out the required information. Registration must be completed within 30 days of purchase. If you do not have access to a computer, you can call our toll free number at 1-888-811-9111, and one of our customer service representatives will register the product for you. If you were unable to register your product within 30 days of purchase, we will accept all products for repair with a proof of purchase. We strongly recommend keeping the original receipt. If your product is not registered and a proof of purchase is not available at the time of service, Dogtra will estimate the age of the unit by the serial number. Serial number estimates can differ from the actual purchase date. A serial number estimate is the only method of determining an approximate date of purchase without product registration or a proof of purchase.

### **Not Covered Under Warranty**

Dogtra DOES NOT offer warranty for products that have been bought secondhand or as a resold product.



Dogtra DOES NOT replace defective units or provide refunds for products purchased from us after 30 days from the date of purchase.

Dogtra DOES NOT cover the cost of shipping outside of the Continental United States.

Issues of replacement and refunds on units purchased less than 30 days from an authorized dealer must be addressed to the dealer directly. If the products purchased from an authorized dealer are after 30 days from the date of purchase, please send the units to Dogtra for service and repair.

Dogtra DOES NOT cover the cost of repairs and replacements due to misuse by the owner or dog, improper maintenance, and/or lost units. Any water damage on the Water Resistant Transmitters of the 175NCP, 180NCP, 200NCP series, 1400NCP Series, 1500NCP Series, and iQ, and the Water Resistant Receivers of the RRS, RRD, and RR Deluxe, will not be covered. All replacement costs for either the transmitter or receiver will be the owner's responsibility.

The warranty is void if the unit has been altered or an unauthorized person has damaged the unit while attempting repair work.

Battery replacement by the customer during the first year of the 1-Year Comprehensive Warranty is not recommended. If the customer chooses to replace the batteries, any damage to the unit during the change-out by the owner will void the warranty.

The removal of serial numbers from any Dogtra products will void the warranty.

Dogtra reserves the right to retain and discard any parts or accessories that have been found damaged upon replacement and repair.

### **Procedure for Repair Work**

If the unit is malfunctioning, please refer to the "Trouble Shooting Guide" in the Owner's Manual and call customer service at 1-888-811-9111, for technical support, before sending it to Dogtra for Service.

The cost of shipping products under warranty back to Dogtra is the customer's responsibility. Dogtra is not responsible for units damaged or lost in transition to Dogtra. Dogtra is not responsible for loss of training time or inconvenience while the unit is in for repair work. Dogtra does not provide loaner units or any form of compensation during the repair period. A copy of the sales receipt showing the purchase date may be required before warranty work is initiated.

Please include a brief explanation outlining the problem and include your name, address, city/state/zip code, daytime phone number, evening phone number, and email address. Or you can visit our website at [www.dogtra.com](http://www.dogtra.com) for a service request form. If the repair costs are not covered under warranty, we will call you for payment information and authorization. For any questions concerning your Dogtra products, call us toll free at 1-888-811-9111, M-F 8:30AM - 4:00PM, Pacific Standard Time, or email us at [repair@dogtra.com](mailto:repair@dogtra.com) for specific repair inquiries.

Send repair units to :

Dogtra Company / Repairs  
22912 Lockness Avenue  
Torrance, CA 90501  
U.S.A.

The diagrams and representations in the manual may differ slightly from the actual product depending on the model type.