



WHITE-RODGERS

1F91-71

Multi-stage Electronic Digital Thermostat
INSTALLATION INSTRUCTIONS

Operator: Save these instructions for future use!

FAILURE TO READ AND FOLLOW ALL INSTRUCTIONS CAREFULLY BEFORE INSTALLING OR OPERATING THIS CONTROL COULD CAUSE PERSONAL INJURY AND/OR PROPERTY DAMAGE.

DESCRIPTION

This wall-mounted, low voltage thermostat maintains room temperature by controlling the operation of multi-stage systems. Use this thermostat for applications requiring up to three stages of heat and up to two stages of cool. Indicator lights show the system status. The user may program up to four time/temperature settings per 24 hour period. The thermostat stores settings for a five-day (weekday) program and a two-day (weekend) program. The thermostat will store both heating and cooling programs simultaneously. A 9 volt Energizer® battery will maintain the stored program for approximately one week, if incoming power should fail. If power failure is extensive and the program is lost, after power restoration, the thermostat will automatically maintain a factory preprogrammed heating temperature of 64°F or a cooling temperature of 82°F.

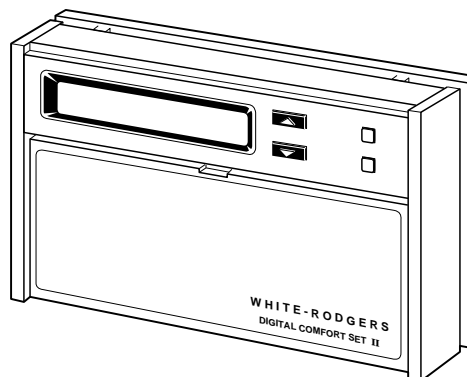

PRECAUTIONS

If in doubt about whether your wiring is millivolt, line, or low voltage, have it inspected by a qualified heating and air conditioning contractor, electrician, or someone familiar with basic electricity and wiring.

All wiring must conform to local and national electrical codes and ordinances.

Do not exceed the specification ratings.

This control is a precision instrument, and should be handled carefully. Rough handling or distorting components could cause the control to malfunction.

CONTENTS

Description	1
Precautions	1
Specifications	2
Installation	2
New Installation	
Select Thermostat Location	
Route Wires to Location	
Replacement Installation	
Remove Old Thermostat	
Attach Subbase to Wall	
Attach Thermostat to Subbase	
Operation	6
System Configuration	
Set Option Switches	
Check Thermostat Operation	
Fan Operation	
Heating System	
Cooling System	
Troubleshooting	

CAUTION

To prevent electrical shock and/or equipment damage, disconnect electric power to system, at main fuse or circuit breaker box, until installation is complete.

WARNING

Do not use on circuits exceeding specified voltage. Higher voltage will damage control and could cause shock or fire hazard.

Do not short out terminals on gas valve or primary control to test. Short or incorrect wiring will burn out thermostat and could cause personal injury and/or property damage.

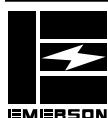

WHITE-RODGERS DIVISION
EMERSON ELECTRIC CO.
9797 REAVIS ROAD
ST. LOUIS, MISSOURI 63123-5398

Printed in U.S.A.

PART NO. 37-4740B
Replaces 37-4740A
9307

SPECIFICATIONS

THIS CONTROL IS DESIGNED FOR USE WHERE BOTH SIDES OF THE TRANSFORMER ARE PRESENT TO THE THERMOSTAT (both the hot and common sides of the 24vAC end of the transformer.)

ELECTRICAL DATA

Electrical Rating:

- 20 to 30v AC 50/60 Hz.
- 0.01 to 1.5 Amps (Load per terminal)
- 2.5 Amps Maximum Total Load** (All terminals combined)

Anticipation:

- Heating 4 to 40
 - Cooling 4 to 40
- } **Reference Values**

STAGING DATA

- Up to 3 heating stages
- Up to 2 cooling stages

THERMAL DATA

Setpoint Temperature Range:

40°F to 99°F (4°C to 37° C)

Operating Ambient Temperature Range:

32°F to 105°F

Operating Humidity Range:

0 to 90% (non-condensing)

Shipping Temperature Range:

-40°F to 150°F

ACCESSORIES

Remote Sense Kit W. R. Part No. F145-1049

Thermostat Guard W. R. Part No. F29-0198 (clear) or F29-0238 (opaque)

INSTALLATION

NEW INSTALLATION

IT IS RECOMMENDED THAT YOU PROGRAM THE THERMOSTAT WITH BATTERY INSTALLED BEFORE ATTACHING ON SUBBASE. SEE OPERATION GUIDE FOR PROGRAMMING INSTRUCTIONS.

SELECT THERMOSTAT LOCATION

Proper location insures that the thermostat will provide a comfortable building temperature. Observe the following general rules when selecting a location:

1. Locate thermostat about 5 ft. above the floor.
2. Install thermostat on a partitioning wall, not on an outside wall.
3. Never expose thermostat to direct light from lamps, sun, fireplaces or any temperature radiating equipment.
4. Avoid locations close to windows, adjoining outside walls, or doors that lead outside.
5. Avoid locations close to air registers or in the direct path of air from them.
6. Make sure there are no pipes or duct work in that part of the wall chosen for the thermostat location.
7. Never locate thermostat in a room that normally warmer or cooler than the rest of the building.
8. Avoid locations with poor air circulation, such as behind doors or in alcoves.

ROUTE WIRES TO LOCATION

All wiring must conform with local and national electrical codes and ordinances.

1. Probe for obstructions in partition before drilling 1/2" hole in wall at selected location. Take up quarter round and drill a small guide hole for sighting (see fig. 1). From basement, drill 3/4" hole in partition floor next to guide hole. In buildings without basements, drill 1/2" hole through ceiling and into partition from above (see fig. 1).
2. Through this hole drop a light chain, or 6" chain attached to a strong cord. Snag cord in basement with hooked wire. In buildings without basements, drop cord through hole in ceiling and down partitioning; snag cord at the thermostat location.
3. Attach thermostat wires to cord and pull wires through hole in wall so that at least 6" of wires protrudes.

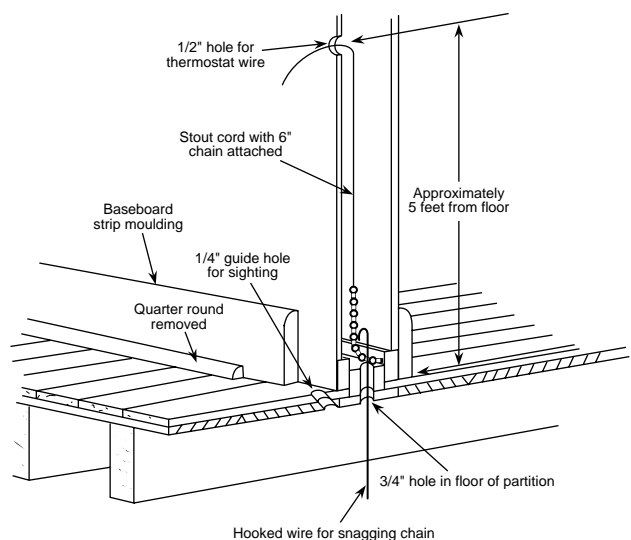

Figure 1. Routing thermostat wires

REPLACEMENT INSTALLATION

REMOVE OLD THERMOSTAT

1. Shut off electricity at the main fuse box until installation is complete. Verify power is off with a voltmeter.
2. Remove the front cover of the old thermostat. **With wires still attached**, remove wall plate from the wall.
3. If the old thermostat has a wall mounting plate, remove the thermostat and the wall mounting plate as an assembly.
4. Use the Cross Reference Guide to find the thermostat type you are replacing.
5. **Identify each wire attached to the old thermostat using the labels enclosed with the new thermostat. Record the identification of the wire on the corresponding blank in Table 2.**
6. Disconnect the wires from old thermostat one at a time. Pull **at least 6 inches** of wire out of the wall. **DO NOT LET WIRES FALL BACK INTO THE WALL.**
7. Install new thermostat using the following procedures.

ATTACH SUBBASE TO WALL

1. Remove the packing material from the thermostat. Place the fingers of one hand on the center top and bottom portion of the thermostat. Grasp the subbase in the other hand on the top and bottom center, and gently pull straight out (see fig. 2). The thermostat has pin and socket connectors. Forcing or prying on the thermostat will cause damage to the unit.

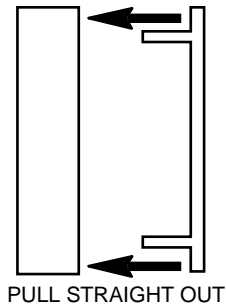

Figure 2. Removing thermostat from subbase

TABLE 1. WIRE IDENTIFICATION LABELS

1 G	2 C	3 L	4 R	5 O	6 B	7 E1	8 E2
G 1	C 2	L 3	R 4	O 5	B 6	E1 7	E2 8
9 Y1	10 Y2	11 W1	12 W2	13 W3	14 S1	15 S2	16 S3
Y1 9	Y2 10	W1 11	W2 12	W3 13	S1 14	S2 15	S3 16

NOTE

THIS THERMOSTAT REQUIRES BOTH THE HOT AND COMMON SIDES OF THE 24vAC TRANSFORMER TO BE PRESENT TO THE THERMOSTAT FOR OPERATION.

TABLE 2. TERMINAL REFERENCE

LABEL NUMBER	1F91-71 TERMINAL DESIGNATION	FUNCTION	OLD THERMOSTAT TERMINAL DESIGNATION
(1)	G	Fan output	_____
(2)	C	Transformer 24vAC common	_____
(3)	—	—	_____
(4)	R	Transformer 24vAC hot	_____
(5)	O	Changeover output (cool)	_____
(6)	B	Changeover output (heat)	_____
(7)	—	—	_____
(8)	—	—	_____
(9)	Y1	Stage 1 cool	_____
(10)	Y2	Stage 2 cool	_____
(11)	W1	Stage 1 heat	_____
(12)	W2	Stage 2 heat	_____
(13)	W3	Stage 3 heat	_____

2. Connect wires beneath terminal screws on subbase using wiring schematic (see figs. 3 through 6).
3. Place subbase over hole in wall and mark mounting hole locations on wall using subbase as a template.
4. Move subbase out of the way. Drill mounting holes.
5. Fasten subbase loosely to wall, as shown in fig. 3, using two mounting screws. Place a level against bottom of subbase, adjust until level, and then tighten screws. (Leveling is for appearance only and will not affect thermostat operation.) If you are using existing mounting holes, or if holes drilled are too large and do not allow you to tighten subbase snugly, use plastic expansion plugs to secure subbase.
6. Push excess wire into wall and plug hole with a fire-resistant material (such as fiberglass insulation) to prevent drafts from affecting thermostat operation.

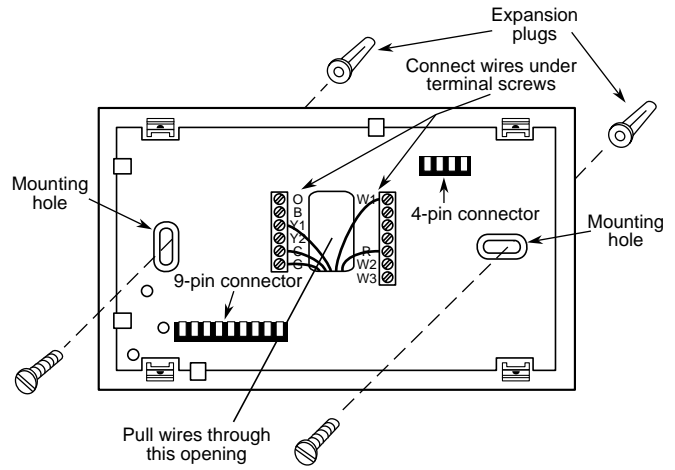

Figure 3. Subbase

⚠ WARNING

DO NOT EXCEED MAXIMUM VOLTAGE OR CURRENT RATINGS. FIRE, PERSONAL INJURY, AND/OR EQUIPMENT DAMAGE COULD RESULT.

⚠ CAUTION

To prevent electrical shock and/or equipment damage, disconnect electrical power at the main fuse box until installation is complete. Verify power is off with a voltmeter.

NOTE

The following wiring diagrams show typical terminal identification and wiring. For proper installation, refer to the original manufacturers' instructions.

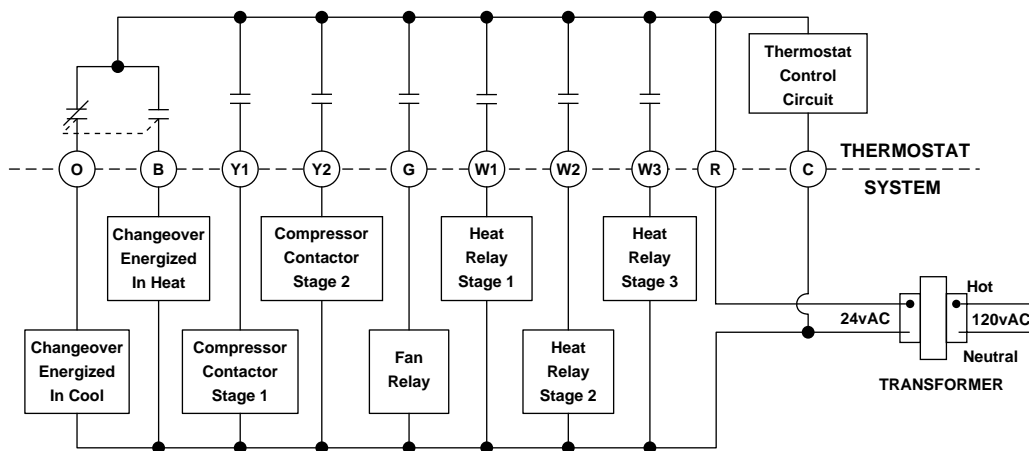

Figure 4. Typical wiring diagram for single transformer systems

NOTE

IF SAFETY CIRCUITS ARE IN ONLY ONE OF THE SYSTEMS, REMOVE THE TRANSFORMER OF THE SYSTEM WITH **NO** SAFETY CIRCUITS.

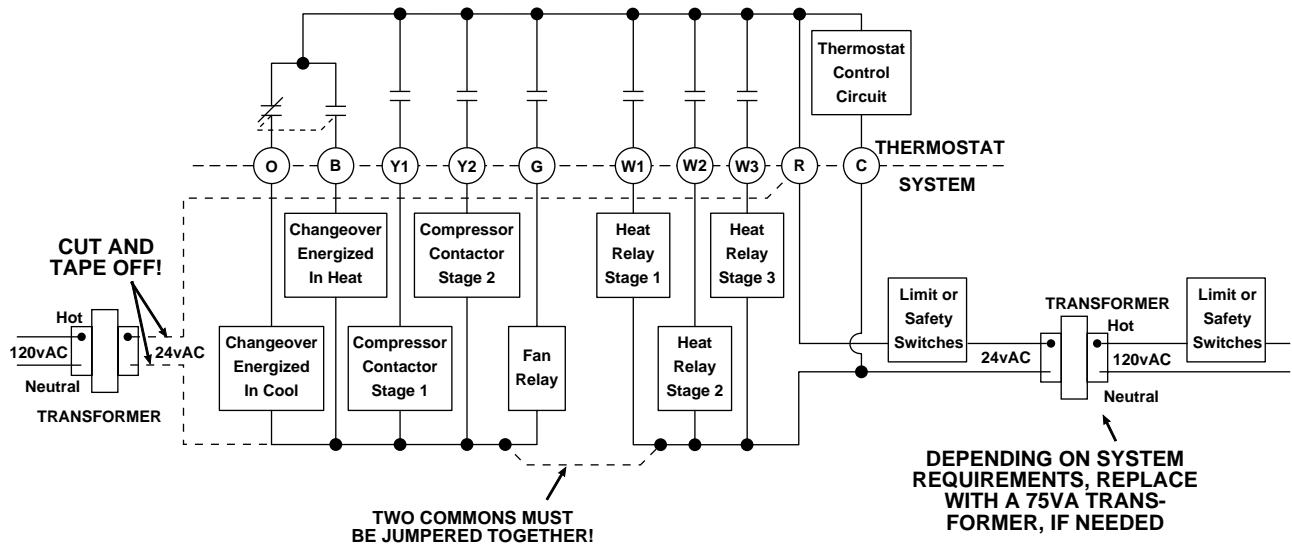

Figure 5. Typical wiring diagram for two-transformer systems with NO safety circuits

NOTE

Relay contacts shown are thermostatically operated. The accessory relay scheme is required when safety circuits exist in both systems.

CAUTION

Polarity must be observed. If the HOT side of the second transformer is jumpered to the COMMON side of the first transformer, a short will be made. Damage to equipment will occur when power is restored.

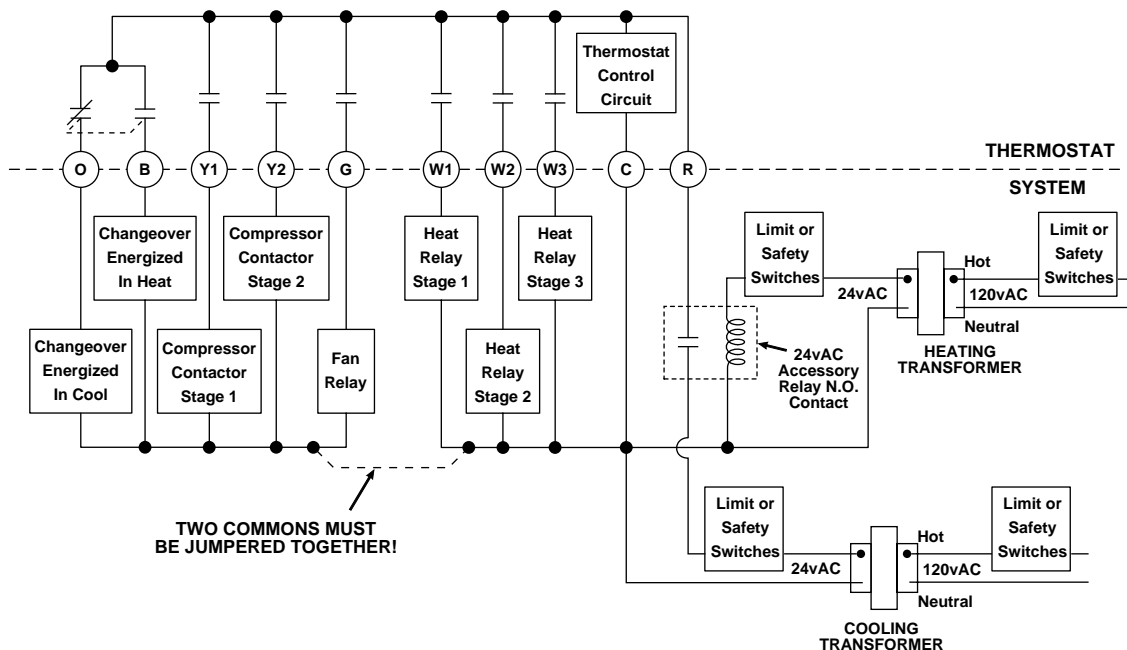

Figure 6. Typical wiring diagram for two-transformer systems with safety circuits in BOTH systems

ATTACH THERMOSTAT TO SUBBASE

IT IS RECOMMENDED THAT YOU SET OPTION SWITCHES TO DESIRED POSITION BEFORE ATTACHING ON SUBBASE (see OPERATION). IT IS ALSO RECOMMENDED THAT YOU PROGRAM THE THERMOSTAT WITH BATTERY INSTALLED BEFORE ATTACHING ON SUBBASE (see OPERATION GUIDE for programming instructions).

POWER TO THERMOSTAT MUST BE OFF BEFORE ATTACHING THERMOSTAT TO WALL. FAILURE TO TURN OFF POWER BEFORE ATTACHING THERMOSTAT MAY CAUSE EQUIPMENT DAMAGE DUE TO RAPID COMPRESSOR CYCLING.

To attach thermostat to subbase, line up the plastic snap guides at the top of the thermostat and the 4 connector pins on the thermostat with the connectors near the top right section of the subbase (when viewed from the front). Gently pivot the thermostat down until the 9-pin connector

and the plastic snaps lock into place (see fig. 7). **Be gentle when attaching thermostat.** If the thermostat does not seem to be attaching to the subbase easily, make sure that the connector pins and plastic snaps are properly aligned, and that excess wire is pushed into the wall. **Damage to the thermostat may occur if force is used.**

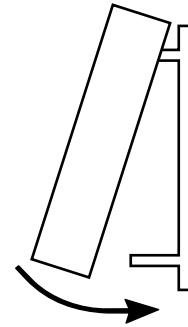

ENGAGE TWO UPPER GUIDES;
PIVOT DOWN

Figure 7. Attaching thermostat to subbase

OPERATION

SYSTEM CONFIGURATION

NOTE

ANY TIME AN OPTION SWITCH IS CHANGED, THE 9 VOLT ENERGIZER® BATTERY MUST BE REMOVED FOR A MINIMUM OF 2 MINUTES.

SET OPTION SWITCHES

1. **Multi-stage Systems** — up to 3 heat stages and 2 cool stages

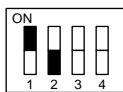

Switch #1 **ON**
Switch #2 **OFF**
Switch #3 (see step 3)
Switch #4 (see step 4)

2. **Electric Heat Systems**

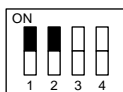

Switch #1 **ON**
Switch #2 **ON**
Switch #3 (see step 3)
Switch #4 (see step 4)

3. **Economizer** — 1st stage cooling

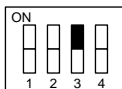

Switch #1 (see steps 1-2)
Switch #2 (see steps 1-2)
Switch #3 **ON**
Switch #4 (see step 4)

4. **Automatic Changeover from Heat to Cool**



Switch #1 (see steps 1-2)
Switch #2 (see steps 1-2)
Switch #3 (see step 3)
Switch #4 **ON**

NOTE

The battery maintains the stored program in the event of a power failure. When attached to the wall with 24v AC power applied, the thermostat will function normally without the battery. However, the program will be lost in the event of a power failure or interruption if the battery is **not** installed. When power is restored, the thermostat will automatically maintain a heating temperature of 64°F or a cooling temperature of 82°F (factory preprogrammed) as needed.

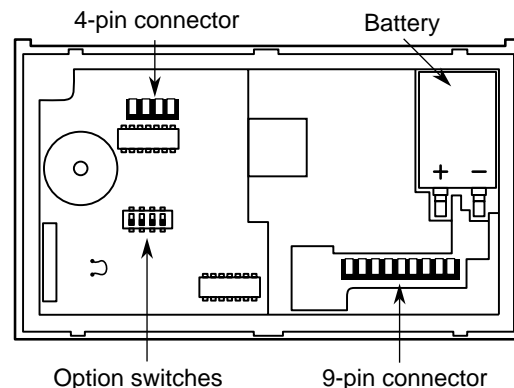



Figure 8. Back of thermostat

CHECK THERMOSTAT OPERATION



FAN OPERATION

1. Turn on power to the system. If the heat source has a standing pilot, be sure to light it.
2. Press  until **FAN ■** is displayed. The blower should begin to operate.
3. Press  until **FAN □** is displayed. The blower should stop operating within approximately one minute.

HEATING SYSTEM

NOTE



When checking thermostat, option switch #4 (for automatic changeover) must be in the **OFF** position, to allow temporary setting of heat setpoints above cool settings. After system checkout, reset option switch #4 to the **ON** position if automatic changeover is desired (see **SYSTEM CONFIGURATION**).

1. Press  until **HEAT** is displayed (it may already be displayed).
2. Press  to adjust thermostat to 99°F. All stages of the heating system should begin to operate within five minutes (if the compressor is not operating, it may be locked out. See **LOCKOUT BYPASS OPTION**).

COOLING SYSTEM

⚠ CAUTION

To prevent compressor and/or property damage, if power to the compressor has been off or interrupted for more than 1 hour and the outdoor temperature is below 50°F, **DO NOT** operate the system for at least the amount of time the compressor was off! This will allow the compressor heaters to warm the compressor oils to avoid damage due to slugging.

1. Press  until **COOL** is displayed.
2. Press  to adjust the thermostat to 40°F. All stages of the cooling system should come on within five minutes (if the compressor is not operating, it may be locked out. See **LOCKOUT BYPASS OPTION**).

After heating and cooling system have been checked and are running properly, determine if automatic changeover is desired (see **SYSTEM CONFIGURATION**).

Refer to the **OPERATION GUIDE** if you need additional information on thermostat operation.

TROUBLESHOOTING

Refer to the **Question & Answer** section of the **OPERATION GUIDE** for information on troubleshooting the thermostat.



LOCKOUT BYPASS OPTION

⚠ CAUTION

FOR QUALIFIED SERVICE TECHNICIANS' USE ONLY. OPERATORS SHOULD NOT USE THIS FEATURE DUE TO POSSIBILITY OF EQUIPMENT OR PROPERTY DAMAGE, OR PERSONAL INJURY.

DO NOT USE THE LOCKOUT BYPASS OPTION UNLESS THE COMPRESSOR OIL HEATERS HAVE BEEN OPERATIONAL FOR 6 HOURS AND THE SYSTEM HAS NOT BEEN OPERATIONAL FOR AT LEAST 5 MINUTES.

COMPRESSOR SHORT TERM CYCLE PROTECTION

This thermostat has a built-in short term (5-minute) time delay. During this 5-minute period, the thermostat will lock out the compressor to allow head pressure to stabilize. If you want to override this feature while testing thermostat operation, simply press  and  buttons at the same time at initial startup.

If you need further information about this product, please write to

White-Rodgers Division, Emerson Electric Co.
9797 Reavis Road
St. Louis, MO 63123-5398
Attention: Technical Service Department

WARRANTY INFORMATION

THIS WARRANTY STATEMENT SUPERSEDES ALL WARRANTY STATEMENTS DATED PRIOR TO OCTOBER 1, 1991.

White-Rodgers Division of Emerson Electric Co. ("Seller") warrants that its products purchased for resale (the "Products") will be free from defects in material and workmanship under normal use and service for a period of twelve (12) months from date of installation. Seller's obligation under this warranty, and Purchaser's exclusive remedy for the breach thereof, shall be limited to, at Seller's option, Seller's replacement of any defective Product F.O.B. Seller's factory (excluding the cost of labor and any other expenses incurred in servicing the unit on which the Product is installed), or Seller's issuance of a credit in the amount of the purchase price of such Product for resale as described below. Seller shall have the option of requiring the return of any defective Product, transportation charges prepaid, before recognizing any claim. This warranty shall not apply to any Product (1) which has been repaired or altered outside Seller's factory by other than Seller in any manner so as, in Seller's judgment, to affect its serviceability or proper operation; (2) which has been subjected by persons other than Seller to improper handling, operation, maintenance, repair or alteration; or (3) which has been subjected to misuse, negligence, or accident.

This warranty extends only to persons or organizations who purchase the Products for resale. THE FOREGOING CONSTITUTES SELLER'S SOLE RESPONSIBILITY UNDER THIS WARRANTY, AND PURCHASER'S EXCLUSIVE REMEDY FOR THE BREACH THEREOF. EXCEPT AS OTHERWISE EXPRESSLY SET FORTH IN THIS AGREEMENT, THERE ARE NO OTHER WARRANTIES, EXPRESS OR IMPLIED, WHETHER OF MERCHANTABILITY, FITNESS FOR A PARTICULAR PURPOSE, OR OTHERWISE. SELLER SHALL NOT BE LIABLE FOR ANY SPECIAL, INDIRECT, INCIDENTAL OR CONSEQUENTIAL DAMAGES OF ANY CHARACTER IN CONNECTION WITH THE SALE, RESALE OR USE OF THE PRODUCTS.

Complete warranty information and instructions for replacing/returning warranty products can be found in the White-Rodgers Product Catalog, or by telephoning or writing to:

White-Rodgers Division
Emerson Electric Co.
9797 Reavis Road
St. Louis, Missouri 63123-5398
(314) 577-1300

WARRANTY INFORMATION FOR CONSUMERS

When you purchase a White-Rodgers Division product, it is typically for replacement of a device which has failed on existing residential or commercial equipment, or a component of new equipment purchased for modernization.

While our warranty does not extend to you, your contractor or dealer is protected by a one-year product warranty from White-Rodgers. Your supplier can rely on a nearby White-Rodgers wholesaler for prompt credit or replacement.