

---

# Clarke®

**Operator's  
Manual**

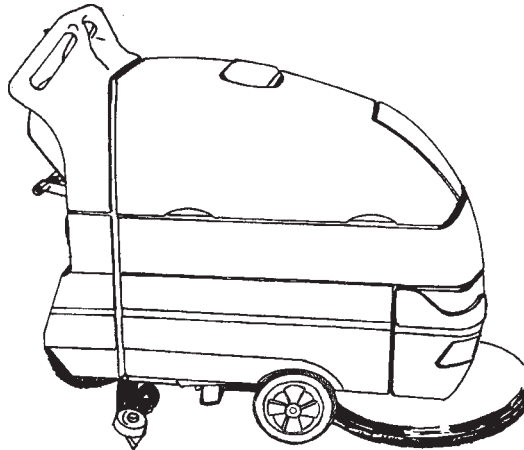

**ENCORE  
S20E**

## **READ THIS BOOK**

This book has important information for the use and safe operation of this machine. Failure to read this book prior to operating or attempting any service or maintenance procedure to your Clarke machine could result in injury to you or to other personnel; damage to the machine or to other property could occur as well. You must have training in the operation of this machine before using it. If you or your operator(s) cannot read English, have this manual explained fully before attempting to operate this machine.

Si Ud. o sus operadores no pueden leer el Inglés, se hagan explicar este manual completamente antes de tratar el manejo o servicio de esta máquina.

All directions given in this book are as seen from the operator's position at the rear of the machine.

For new books write to: Clarke®, 2100 Highway 265, Springdale, Arkansas 72764.

## Table of Contents

Operator Safety Instructions .....	3
Introduction & Machine Specifications .....	5
Procedures for Transporting Machine .....	6
Machine Control Panel .....	8
Machine Controls and Features .....	9
How to Prepare the Machine for Operation .....	10
How to Install a Brush or Pad Driver .....	10
How to Remove a Brush or Pad Driver .....	10
How to Operate the Machine .....	11
How to Operate the Squeegee .....	11
Filling the Solution Tank .....	11
Operating the Machine .....	12
How to Clean a Dirty Floor .....	12

### **SECTION II - Parts and Service Manual**

How to Correct Problems in the Machine .....	14
Maintenance .....	16
Procedures Before Work is Began .....	17
Procedures to Perform at the End of Work .....	18
Procedures to Perform Every Week .....	18
Maintenance for the Squeegee .....	19
How to Adjust the Squeegee .....	19
How to Clean the Solution Line .....	20
Machine Variables and Accessories .....	21
Accessories .....	21
Encore S20E Final Assembly Drawing .....	22
Parts List .....	23
Encore S20E Recovery Drawing .....	24
Parts List .....	25
Solution Tank Assembly Drawing .....	26
Parts List .....	27
Rear Panel Assembly Drawing .....	28
Parts List .....	29
Electrical Cover Assembly Drawing and Parts List .....	30
Squeegee Lift Assembly Drawing and Parts List .....	31
Squeegee Assembly Drawing and Parts List .....	32
Squeegee Assembly Drawing and Parts List .....	33
Encore S20E Frame Assembly Drawing and Parts List .....	34
Brush Lift Assembly Drawing and Parts List .....	35
Brush Housing Assembly Drawing and Parts List .....	36
Optional Brake Assembly Drawing and Parts List .....	37
115V Vacuum Motor Drawing and Parts List .....	38
230V Vacuum Motor Drawing and Parts List .....	39
Gearbox Assembly Drawing and Parts List .....	40
Motor and Gearbox Assembly Drawing and Parts List .....	41
Encore S20E 115V Connection Diagram .....	42
Encore S20E 115V Electrical Schematic .....	43
Encore S20E 230V Connection Diagram .....	44
Encore S20E 230V Electrical Schematic .....	45

# OPERATOR SAFETY INSTRUCTIONS





**WARNING**











**AVERTISSEMENT**



**ADVERTENCIA**

-  **DANGER:** Failure to read and observe all **DANGER** statements could result in severe bodily injury or death. Read and observe all **DANGER** statements found in your Owner's Manual and on your machine.
-  **WARNING:** Failure to read and observe all **WARNING** statements could result in injury to you or to other personnel; property damage could occur as well. Read and observe all **WARNING** statements found in your Owner's Manual and on your machine.
-  **CAUTION:** Failure to read and observe all **CAUTION** statements could result in damage to the machine or to other property. Read and observe all **CAUTION** statements found in our Owner's Manual and on your machine.

-  **DANGER:** Failure to read the Owner's Manual prior to operating or attempting any service or maintenance procedure to your Clarke machine could result in injury to you or to other personnel; damage to the machine or to other property could occur as well. You must have training in the operation of this machine before using it. If you or your operator(s) cannot read English, have this manual explained fully before attempting to operate this machine.
-  **DANGER:** Operating a machine that is not completely or fully assembled could result in injury or property damage. Do not operate this machine until it is completely assembled. Inspect the machine carefully before operation.
-  **DANGER:** Machines can cause an explosion when operated near flammable materials and vapors. Do not use this machine with or near fuels, grain dust, solvents, thinners, or other flammable materials. This machine is not suitable for picking up hazardous dust.
-  **DANGER:** Using a machine with a damaged power cord could result in an electrocution. Do not use the machine if the power cord is damaged. Do not use the electrical cord to move the machine.
-  **DANGER:** Electrocution could occur if maintenance and repairs are performed on a unit that is not disconnected from the power source. Disconnect the power supply before attempting any maintenance or service.
-  **DANGER:** Electrocution or fire could occur if the machine is used on a power circuit that repeatedly trips or is undersized. Have a licensed electrician check the fuse, circuit breaker or power supply, and/or contact your local Clarke distributor for assistance.
-  **WARNING:** Operating this machine from anywhere other than the back of the machine could result in injury or damage. Operate this machine only from the rear.
-  **WARNING:** This machine is heavy. Get assistance before attempting to transport or move it. Use two able persons to move the machine on a ramp or incline. Always move slowly. Do not turn the machine on a ramp. If operating machine on a gradient over 2%, do not stop, turn or park. Read the "Procedures For Transporting" in this manual before transporting as machine might topple over if not strapped..
-  **WARNING:** Machines can topple over if guided over the edges of stairs or loading docks and cause injury or damage. Stop and leave this machine only on a level surface. When you stop the machine, put all switches into their "OFF" position.



**WARNING:** Maintenance and repairs performed by unauthorized personnel could result in damage or injury. Maintenance and repairs must be performed by authorized Clarke personnel only.



**WARNING:** Any alterations or modifications of this machine could result in damage to the machine or injury to the operator or other bystanders. Alterations or modifications not authorized by the manufacturer voids any and all warranties and liabilities.



**WARNING:** Electrical components of this machine can "short-out" if exposed to water or moisture. Keep the electrical components of the machine dry. Wipe the machine down after each use. For storage, keep the machine in a dry building.



**WARNING:** Operating a machine without observing all labels and instructional information could result in injury or damage. Read all machine labels before attempting to operate. Make sure all of the labels and instructional information are attached or fastened to the machine. Get replacement labels and decals from your Clarke distributor.



**WARNING:** Wet floor surfaces can be slippery. Water solutions or cleaning materials used with this type of machine can leave wet areas on the floor surface. These areas can cause a dangerous condition for the operator or other persons. Always put "Caution" signs around/near the area you are cleaning.



**WARNING:** Improper discharge of waste water may damage the environment and be illegal. The United States Environmental Protection Agency has established certain regulations regarding discharge of waste water. Also, city and state regulations regarding this discharge may be in effect in your area. Understand and follow the regulations in your area. Be aware of the environment hazards of chemicals that you dispose.



**CAUTION:** Use of this machine to move other objects or to climb on could result in injury or damage. Do not use this machine as a step or furniture. Do not ride on this machine.



**CAUTION:** Your machine warranty will be voided if anything other than genuine Clarke parts are used on your machine. Always use Clarke parts for replacement.



**CAUTION:** Using an extension cord with this machine will result in a drop in voltage and loss of power. Use of an extension cord is not recommended.

## Introduction & Machine Specifications

### Introduction & Machine Specifications

Clarke's newly designed Encore S20E automatic scrubber is an efficient and superior floor cleaning machine. The Encore uses one brush to scrub a path 20 inches wide. A squeegee wipes the floor while the vacuum motor removes the dirty solution from the floor - all in one pass.

The Encore S20E automatic scrubber comes complete with either a scrub brush or a pad driver, and one operator's manual.

#### SPECIFICATIONS:

Model	Encore S20E - 00900A	Encore S20E 00910A
Model	w/Brake - 00800E	w/Brake - 00910E
Motor, Vac	1 HP two stage tangential discharge	
Power Supply	75' cord	
Solution Tank	14 gallons	
Recovery Tank	14 gallons	
Parabolic Squeegee	32" (81cm) hard width with 34" (86cm) flex blade width	
Motor, Brush	.75 hp PM	
Brush	20 inch	
Brush Speed	250 rpm	
Brush Pressure	Floating	
Speed, Forward	brush assist.	
Drive Wheels	8" x 2" Neoprene thread	
Length	52½"	
Width (over brush housing)	22¼"	
Height	43½"	
Sound Level (DBA)	78	
Cleaning Swath	20 inch	
Weight (Dry)	338 lbs.	153 kg
Shipping Weight	350 lbs.	187 kg
Shipping Dimensions	28" x 65.5" x 46.5"	

## Procedures For Transporting

### How to Put the Machine Into a Van or Truck

 **WARNING:** This machine is heavy. Get assistance before attempting to transport or move it. Use two able persons to move the machine on a ramp or incline. Always move slowly. Do not turn the machine on a ramp. Do not stop and leave the machine on a ramp or incline. The loading ramp must be a minimum of 32" wide.

 **WARNING:** Machines can topple over if guided over the edges of stairs or loading docks and cause injury or damage. Stop and leave this machine only on a level surface. When you stop the machine, put all switches into their "OFF" position.

1. Make sure the loading ramp is at least eight (8) feet long and a minimum of 32" wide, and strong enough to support the machine.
2. Make sure the ramp is clean and dry.
3. Put the ramp in position.
4. Remove squeegee assembly, brush housing and brush or pad driver before loading.
5. Align the machine on a level surface five (5) feet in front of the ramp.
6. Push the machine backwards to the top of the ramp.
7. **Fasten the machine to the vehicle.** Clarke recommends a strap over the top of the machine and a strap to keep the machine from rolling forward or backwards. If this is not done, there is a possibility of the machine toppling over.

## Procedures For Transpoting (cont.)

### How to Remove the Machine From a Van or Truck

1. Make sure there are no obstructions in the area.
2. Make sure the unloading ramp is at least eight (8) feet long and a minimum of 32" wide, and strong enough to support the machine.
3. Make sure the ramp is clean and dry.
4. Put the ramp in position.
5. Unfasten the machine.



**WARNING:** The machine is heavy. Make sure you use two able persons to assist in moving the machine down the ramp.

6. Get two people to pull machine off ramp. It is recommended that the machine be unloaded in the forward position.
7. As the machine begins to travel down the ramp, use two people to maintain a slow downward speed.
8. Replace squeegee assembly, brush housing, and brush or pad driver after machine is unloaded and ready to use.

## Machine Control Panel

### **Main Switch (See Figure 1, Item "A")**

The main switch turns "ON" the power to the control panel. "O" is "OFF" and "I" is "ON".

### **Hour Meter (Optional)**

The hour meter indicates the number of hours the machine has operated. It runs only when the brush motor is on.

### **Circuit Breakers (See Figure 1, Items "B" and "C")**

The circuit breakers reset button are located on the rear cover.

- Item B - Brush Motor (10 amp - 115V)  
(5 amp - 230V)
- Item C - Control Breaker (2.5 A)

If a circuit breaker trips, determine which motor is not operating and turn the main switch "OFF". Wait five minutes and push the reset button back in. Turn the main switch "ON" and try again. An authorized service person should be contacted if the breaker trips again.

### **Control Handles (See Figure 1, Item "D")**

The control handles are located at the rear of the machine. They are used to guide the machine.

### **Solution Control Knob (See Figure 1, Item "E")**

The solution control knob regulates the flow of chemical solution to the floor. To increase the flow, turn knob clockwise. To decrease the flow, turn counter clockwise.

### **Vacuum Motor Switch (See Figure 1, Item "F")**

To activate vacuum motor, lower squeegee handle. Handle has two positions. Lowest position is operating position and the middle position is transport to clear vacuum hose.

### **Brush Motor Switch (See Figure 1, Item "G")**

To activate brush motor, lower handle. Brush Motor and solution flow will activate when the traverse buttons are pushed. To shut brush motor off, raise handle to top position.

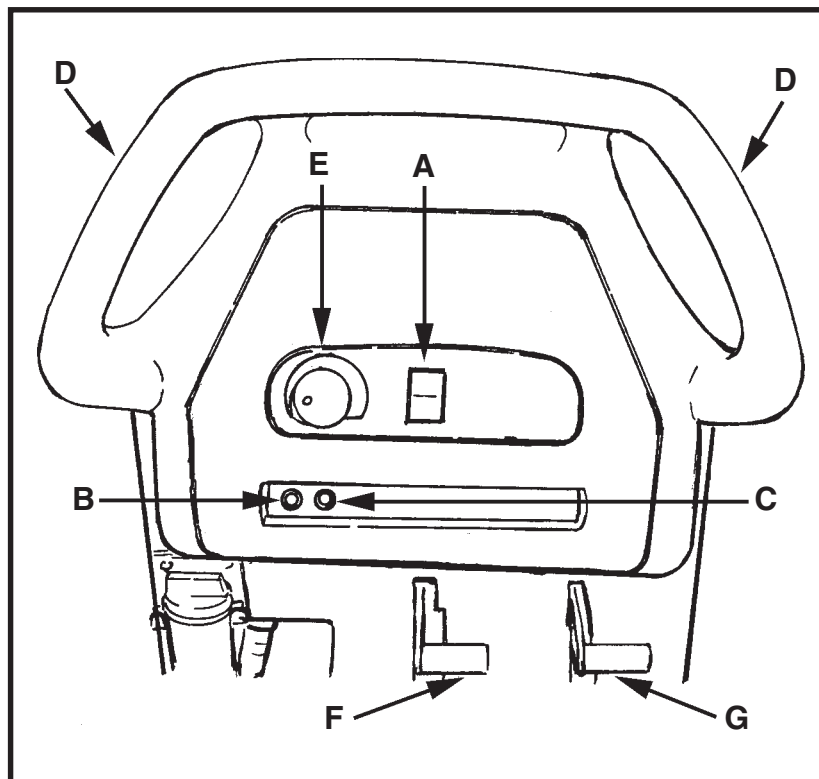

Figure 1



## Machine Controls and Features

### Squeegee Lift Handle, See Figure 2

The squeegee lift handle is located below the control handles in the center. It is used to raise or lower the squeegee. The vac motor is turned on when the handle is lowered to either the first or last position.

**NOTE: Squeegee must be raised to at least the first position when the machine is backed up.**

### Float Shut Off, See Figure 3

The shut-off switch for the vac motor is located in the recovery tank. It automatically turns off the vac motor when the recovery tank is full. **NOTE: If excessive foaming in recovery tank, defoamer must be added. Damage to vacuum motor could result from foam.**

### Parking Brake, See Figures 4a and 4b (Optional)

The parking brake prevents movement of the machine. It is located at the rear lower left side of the machine. To engage the brake, push the pedal down (Figure 4a). To release the brake, lift pedal up (Figure 4b).

**CAUTION:** Do not activate the brake while the machine is moving.

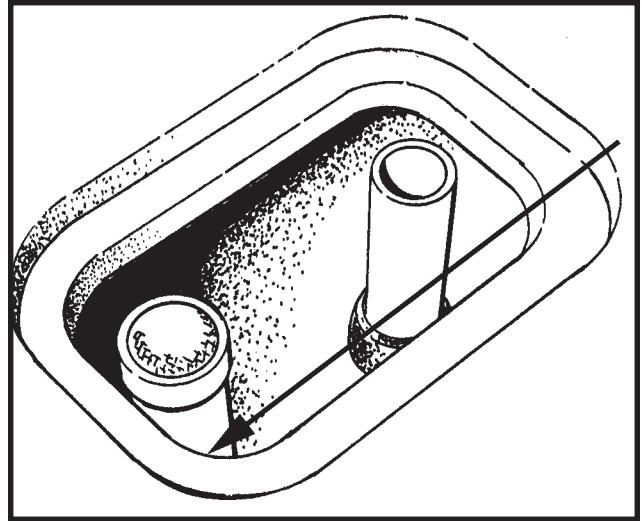

Figure 3

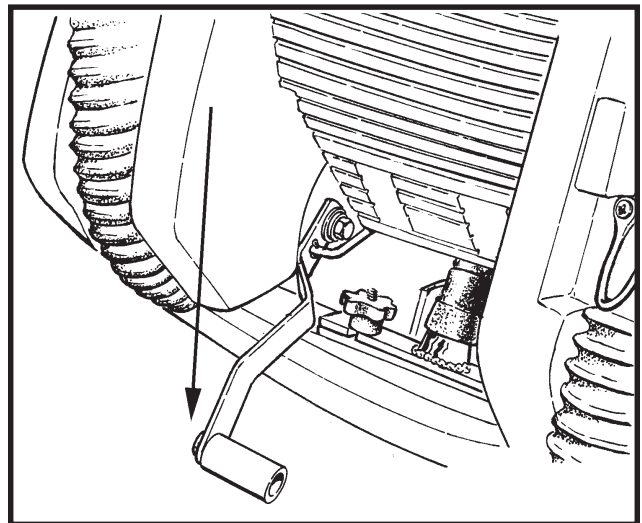

Figure 4a

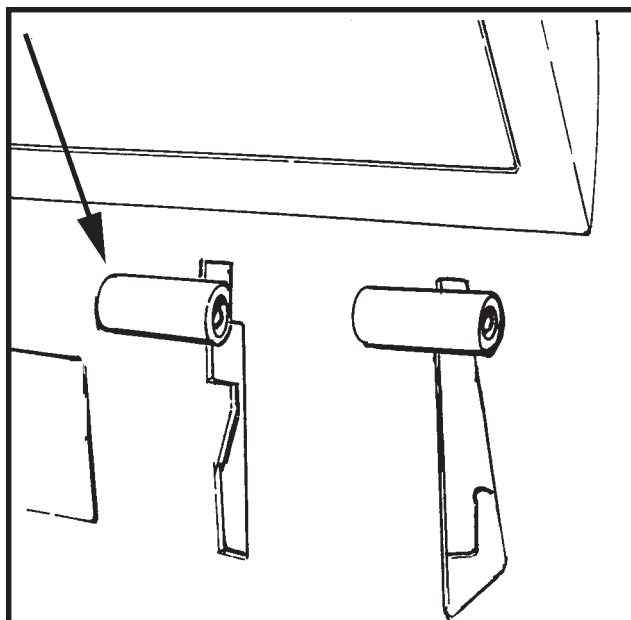

Figure 2

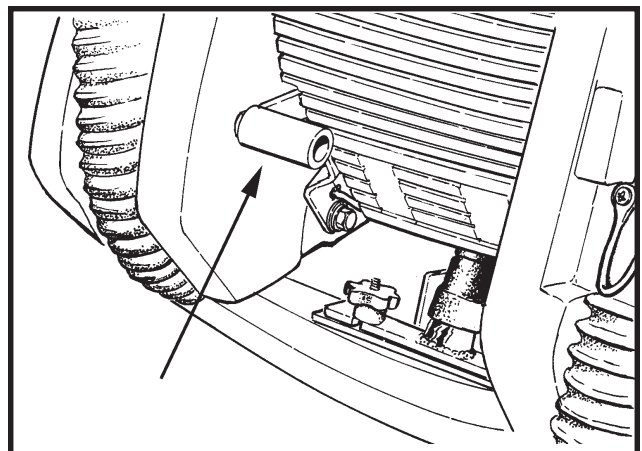

Figure 4b

## How To Prepare the Machine For Operation

### How To Install The Brush Or Pad Driver

To install the brush or pad driver on the machine, follow this procedure:

1. Turn the main switch "OFF".
2. Put the brush lever in the "UP" position.
3. Go to the front of the machine.
4. Using a short Phillips screw driver, loosen the latch screw enough to allow the retainer to be free of the cover. (See figure 5a, 1)
5. Open the brush motor cover and remove the brush housing. See figures 5a and 5b.
6. Put a brush or pad driver under the brush housing. See figure 5c.
7. Align the lugs on the motor with the slots in the brush gimbal.
8. Pull the brush up and rotate counter clockwise until gimbal locks.
9. Replace brush housing and close brush motor cover.
10. Install the brush retainer latch into the brush motor cover. Tighten the retainer screw.

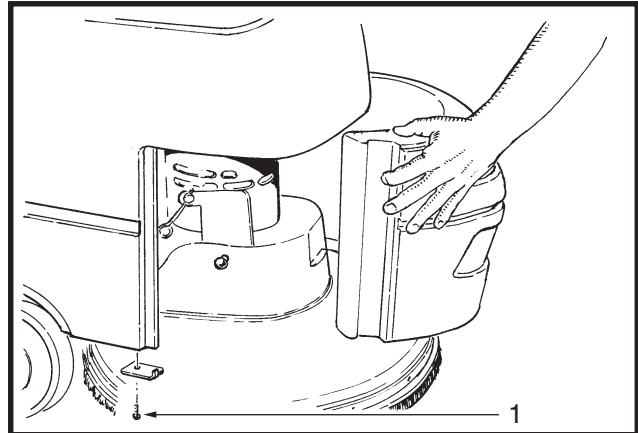

Figure 5a

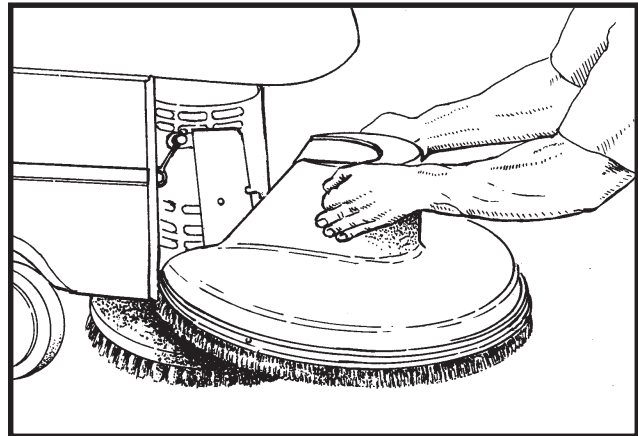

Figure 5b

### How To Remove The Brush or Pad Driver

To remove the brush or pad driver from the machine, follow this procedure:

1. Put the brush lever in the "UP" position.
2. Turn the main switch "OFF".
3. Go to the front of the machine.
4. Open the brush motor cover and remove brush housing. See figures 5a-5c.
5. Rotate brush clockwise with a quick snapping action until brush releases.
6. Replace brush housing and close brush motor cover.

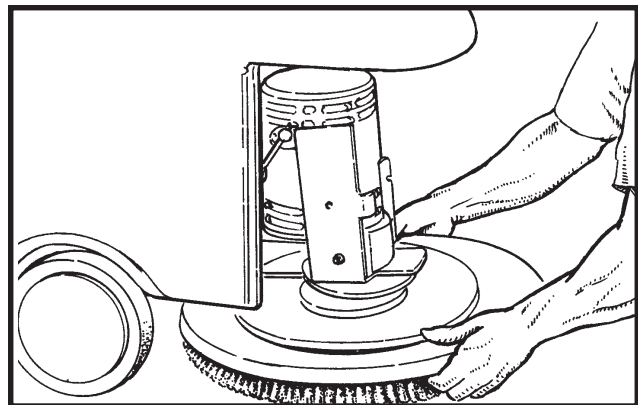

Figure 5c

## How To Operate The Machine

### How To Operate The Squeegee

The squeegee wipes the floor while the vacuum motor removes the dirty solution from the floor. Use your right hand to lower or raise the squeegee handle. To operate the squeegee, follow this procedure:

1. To lower the squeegee and start the vac motor, move the squeegee lever to the right and down. See figure 6.
2. To raise the squeegee, lift the squeegee lever up. See figure 7.

**NOTE:** The center position lets the vac motor continue to run with the squeegee off the floor to avoid drips and also allows you to back up the machine.

### How To Fill The Solution Tank

The solution tank lid is at the front. To fill the solution tank follow this procedure:

1. Raise the solution tank lid.
2. Add a cleaning chemical to the solution tank. For the correct amount of chemical, follow the directions shown on the container.
3. Fill the solution tank with water.
4. Lower the solution tank lid.

**⚠ WARNING:** Water solutions or cleaning materials used with this type of machine can leave wet areas on the floor surface. These areas can cause a dangerous condition for the operator or other persons. Always put CAUTION signs near the area you are cleaning.

**⚠ WARNING:** Machines can ignite flammable materials and vapors. Do not use with or near flammables such as gasoline, grain dust, solvents and thinners. Only use a cleaning concentrate recommended by the chemical manufacturer.

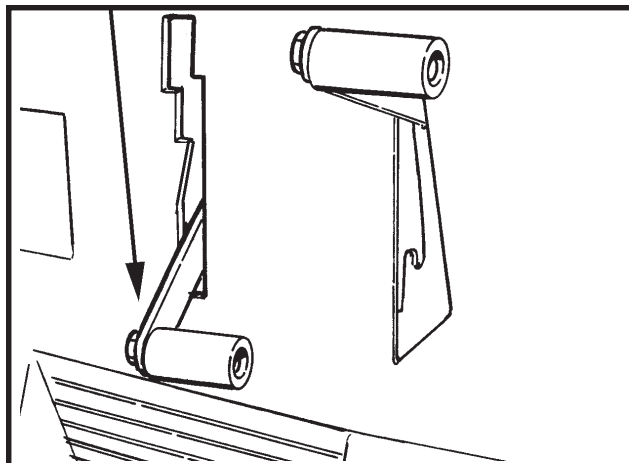

Figure 6

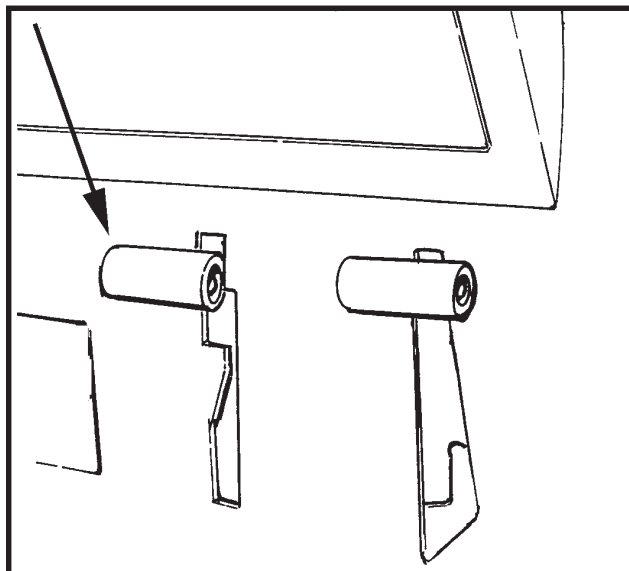

Figure 7

## How To Operate The Machine

### Operating The Machine

1. Move the machine in a straight direction, forward and backward.
2. Stop the machine safely.
3. Turn the machine both left and right and return to a straight direction.

To move the machine, follow this procedure:

1. Release the parking brake (if equipped with machine).
2. Turn the main switch to the "ON" position
3. Raise the brush to the highest setting.
4. Raise the squeegee.
5. Hold the control handle as shown in figure 8.
6. To reverse the machine, pull the machine backwards. **NOTE: Anytime the machine is reversed, the squeegee must be raised to either of the two up positions. This will prevent damage to the squeegee.**
7. To turn the machine, push the rear of the machine to the side.
8. When you stop the machine, turn the main switch "OFF" and set the parking brake (if equipped).

### How To Clean A Floor

**⚠ WARNING:** Water solutions or cleaning materials used with this type of machine can leave wet areas on the floor surfaces. These areas can cause a dangerous condition for the operator or other persons. Always put CAUTION signs near the area you are cleaning.

To clean a floor follow this procedure:

1. Set the parking brake (if equipped with machine.)
2. Put the water and a cleaning chemical in the clean solution tank.
3. Release the parking brake (if equipped with machine.)
4. Turn the main switch "ON".
5. Lower the squeegee.
6. Put the brush lever switch in the floating position.

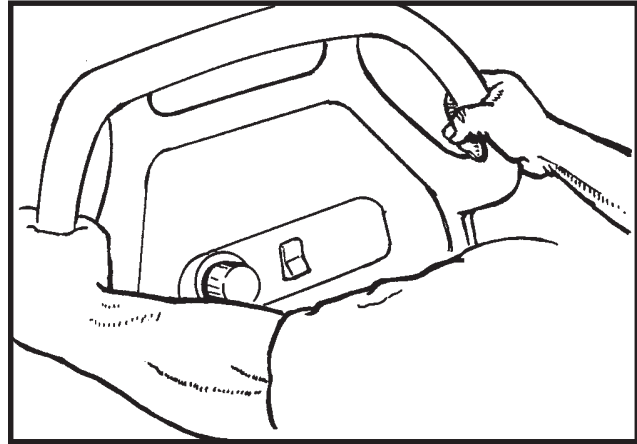

Figure 8

**NOTE:** Keep the machine moving when the brush is rotating on the floor. Pre-wet brush/pad or keep light pressure on brush until solution flow is adequate to keep brush/pad from scratching floor.

7. Turn the solution knob to the right to activate the flow of solution. Adjust the flow of clean solution to the flow desired.
8. Move the machine across the floor in the forward direction.
9. Make a 180° turn.

**NOTE:** When you make more passes across the floor, let the brush clean approximately 2 inches of the area already cleaned by the brush.

**NOTE:** During most cleaning procedures, apply and remove the solution in one operation.

### How To Clean A Very Dirty Floor

To clean a very dirty floor, follow this procedure:

1. Apply solution to the floor.
2. Do not lower the squeegee, which will keep the vacuum motor off.
3. Lower the brush or pad and scrub the floor.
4. Scrub the floor again with additional solution and lower the squeegee.
5. Pick up all the solution with the squeegee.

---

**Clarke<sup>®</sup>**

**ENCORE**

**S20E**

**Section II**

**Parts and Service Manual**









(70658A)

## HOW TO CORRECT PROBLEMS IN THE MACHINE

PROBLEM	CAUSE	ACTION
<b>There is no solution flow.</b>	<p>The solution valve is closed.</p> <p>There is an obstruction in the solution hose or filter.</p> <p>The solution valve or electric wiring is damaged.</p> <p>The solution tank is empty.</p> <p>The solution module is damaged.</p>	<p>Open the solution valve.</p> <p>Remove the obstruction from the hose and the filter.</p> <p>Repair or replace the valve and the electric wiring.</p> <p>Fill the solution tank.</p> <p>Check solution module</p>
<b>The solution flow does not stop.</b>	<p>The solution valve is open or dirty.</p> <p>The solution valve or wiring is damaged.</p> <p>The solution valve is dirty</p> <p>There is a damaged seat and washer in the solution valve.</p> <p>The solution module is damaged.</p>	<p>Close or Clean the solution valve.</p> <p>Repair or replace the valve and the wiring.</p> <p>Clean the solution valve.</p> <p>Replace the seat and washer.</p> <p>Check solution module.</p>
<b>The machine does not remove all the water from the floor.</b>	<p>The squeegee is up</p> <p>The squeegee tilt is not correct.</p> <p>The vacuum tank is full.</p> <p>The screen filter is dirty.</p> <p>There is an obstruction or damage in the squeegee, squeegee hose or standpipe.</p> <p>The vacuum motor is not running.</p> <p>The squeegee hose is disconnected, or damaged</p> <p>The squeegee blade is damaged, worn, or incorrectly installed.</p> <p>The squeegee pressure is not correctly adjusted.</p> <p>The gaskets on the cover of the recovery tank are damaged.</p> <p>The recovery tank lid is on wrong.</p>	<p>Lower the squeegee.</p> <p>(See Figure 11, page 23)</p> <p>Drain the tank.</p> <p>Clean the screen filter.</p> <p>Remove the obstruction or repair the damage.</p> <p>Check for tripped breaker. Have an authorized service person make repairs.</p> <p>Check and connect hose.</p> <p>Turn or replace the squeegee blade. Correctly install the squeegee blade.</p> <p>Adjust the pressure of the squeegee.</p> <p>Replace the gaskets.</p> <p>Rotate lid 180° and replace.</p>

<b>PROBLEM</b>	<b>CAUSE</b>	<b>ACTION</b>
<b>The cleaning is not even.</b>	<p>The scrub brush or pad is worn.</p> <p>There is damage to the brush assembly, caster or the solution valve.</p> <p>The brush motor is not running</p> <p>The solution level is low.</p>	<p>Replace the scrub brush or pad.</p> <p>Have an authorized service person make the needed repairs.</p> <p>Check for tripped breaker. Reset. Check for loose connections.</p> <p>Fill the solution tank.</p> <p>NOTE: If the problem continues consult an authorized service person.</p>
<b>The machine does not run.</b>	<p>The machine loses power</p> <p>Main switch is off.</p> <p>Power cord disconnected.</p> <p>Wall circuit breaker blown.</p>	<p>Reset the circuit breaker.</p> <p>Do not use an extension cord.</p> <p>Turn main switch on.</p> <p>Reconnect power cord.</p> <p>Reset wall circuit breaker.</p>

## MAINTENANCE

-  **DANGER:** Maintenance and repairs performed by unauthorized personnel could result in damage or injury. Maintenance and repairs must be done by authorized Clarke personnel only.
  
-  **DANGER:** Operating a machine that is not completely or fully assembled could result in injury or property damage. Do not operate this machine until it is completely assembled. Inspect the machine carefully before operation. Keep all fasteners tight.
  
-  **DANGER:** Electrocutation could occur if maintenance and repairs are performed on a unit that is not properly disconnected from the power source. Always disconnect the power supply before attempting any maintenance or service.
  
-  **WARNING:** Severe injury could occur to your hands if maintenance or repairs are performed when the machine is on or plugged into power supply. Always turn off power and disconnect machine before attempting any maintenance.
  
-  **WARNING:** SEVERE bodily injury could occur if operator leans body under the tank support to perform maintenance. Always position the tank support all the way over and rest it on the floor before attempting any service and/or maintenance.
  
-  **WARNING:** Moving parts can cause injury to feet and hands. Keep feet and hands clear from under the machine.
  
-  **WARNING:** Attempting maintenance and or repairs to this machine before emptying the solution or recovery tank could result in machine or property damage.
  
-  **WARNING:** Keep all fasteners tight.



## MAINTENANCE

### Do These Procedures When You Begin Your Work Period

**NOTE: Always engage the parking brake (if equipped) before servicing the machine.**

Keep the machine clean. It will need fewer repairs and have a longer life.

1. Connect machine power cord to electrical outlet.
2. Make sure the recovery tank lid is on correctly. See figure 1.
3. Make sure the Screen filter over the vacuum motor is clean and in position. See figure 1 (a)
4. Make sure the valves on the drain hoses are clean. Tightly close the valves.
5. Make sure brush housing and skirt are in position on the brush head.
6. Make sure the brush is in position and installed correctly
7. Check the installation of the squeegee and squeegee hose.

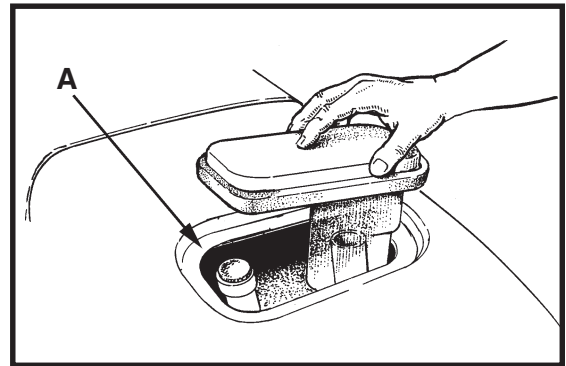

**Figure 1**

## MAINTENANCE

### Do These Procedures When You End Your Work

**NOTE:** Always engage the parking brake (if equipped) before servicing the machine.

1. Drain the solution tank (Figure 2) and the recovery tank (Figure 3). To drain the tanks, follow this procedure:
  - a. Turn the main switch "OFF".
  - b. Remove the drain hose from the back of the machine.
  - c. Put the end of the hose over a drain or bucket.
  - d. Turn the valve handle to the left. Pull the handle out to open the drain. (Figure 4)

**NOTE:** Have the opening in the side of the valve away from you when you open the valve.

- e. To open the valve completely, turn the handle to the right. Pull the handle out of valve. (Figure 5)
2. Flush the tanks. To flush the tanks, put clean water in the tank through the opening on top of the tank.

**CAUTION:** Make sure water or solution does not enter the opening for the vacuum motor. See figure 1, page15.

3. If a tank or drain hose has an obstruction, use a high pressure water hose to flush the tank or hose. Put the water hose into the drain hose.
4. Leave the tanks and the drain valves open to dry in the air.
5. Check the squeegee blade. Use a cloth to clean the squeegee blade. If the squeegee blade is damaged or worn, turn or replace the blade.
6. Check and clean the solution lid gasket. Use a mild cleaning solution and rinse the parts in clean water.

Use a clean cloth and wipe the surface of the machine.

### These Maintenance Procedures Must Be Done Every Week:

**WARNING:** Maintenance and repairs must be done by authorized personnel only. Always empty the solution tank and the recovery tank before doing any maintenance. Keep all fasteners tight.

1. Check the hoses for leaks, obstructions and other damages.

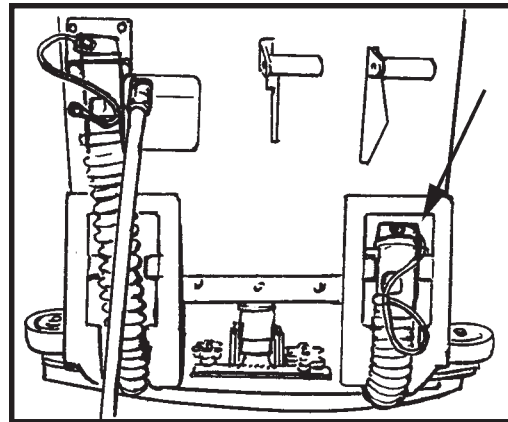

Figure 2

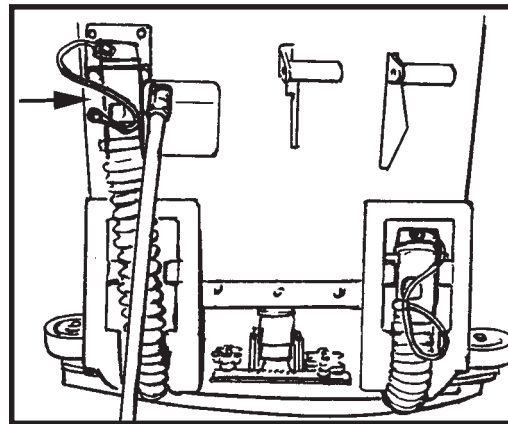

Figure 3

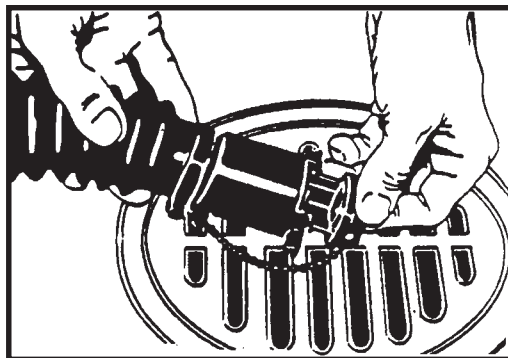

Figure 4

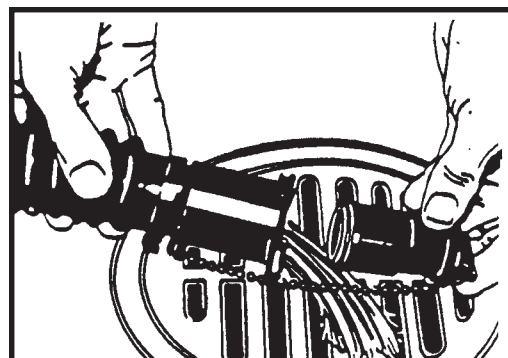

Figure 5

## MAINTENANCE

2. Check and clean the filter screen in the solution hose. To clean the screen, follow this procedure: (See figures 11 and 12 page 18)
  - a. Turn the connector to the left.
  - b. Remove and clean the filter screen.
  - c. Install the filter screen in the hose. Turn the connector to the right to connect the hose.
3. Use a grease gun to lubricate the caster. See figure 6.
4. Check the squeegee and the scrub brush or the pad driver for damage.
5. Check the squeegee and the vacuum hose for damage, leaks and obstructions.

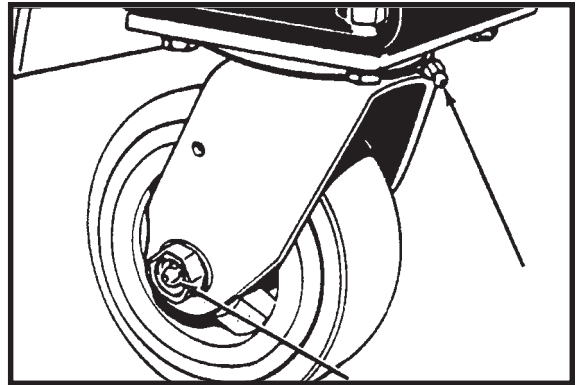

Figure 6

### Maintenance For The Squeegee

To remove the squeegee, follow this procedure:

1. Remove the squeegee assembly by loosening the two knobs that attach the squeegee to the machine. Pull the squeegee assembly off. See figure 7.
2. Inspect the squeegee blade.
3. If the blade is worn, turn the blade so that a new edge is in the wiping position.
4. Reinstall squeegee assembly on the machine.

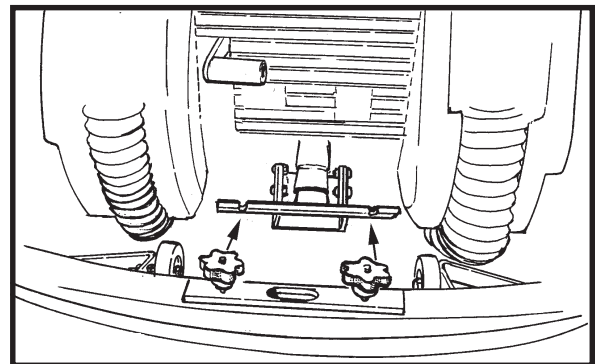

Figure 7

### How To Adjust The Squeegee

The following adjustments are set at the factory, however they may require slight adjustment.

#### **Adjusting Squeegee Pressure:**

To adjust the pressure, refer to Figure 8. Proper adjustment will produce a uniform flare along the rear blade when the machine is moved forward. To increase pressure, loosen bolt and slide squeegee mount down. To decrease the pressure, loosen the bolt and slide squeegee mount up.

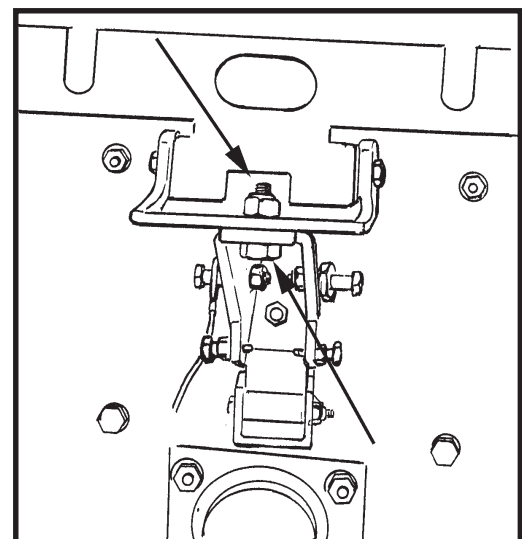

Figure 8

## MAINTENANCE

### How To Adjust The Squeegee cont.

#### **Adjusting Squeegee Tilt:**

The tilt of the squeegee causes the rear blade to raise up in the center or on the ends, depending on which direction the tilt is changed. For tilt adjustment, refer to figure 9. Loosen left and right screw "X". In order to bring the rear blade down in the center, tip "Y" down. To bring both ends down, tip "Y" up. Make very small adjustments and try it until a uniform flare is achieved. Changing the tilt may also require readjusting the squeegee pressure.

#### **Adjusting Squeegee Blades:**

When properly installed the front blade should be approximately .06 above the rear blade. See figure 10.

#### **Adjusting Squeegee Support Wheels:**

The support wheels should be set at .12 above the floor with the rear blade touching the floor. See figure 10.

 **WARNING:** Maintenance and repairs must be done by authorized personnel only .

 **WARNING:** Electrical repairs must be done by authorized personnel only.

Consult your Clarke Authorized Service Person to do the service procedures.

Use only genuine Clarke parts.

#### **NOTE: ONLY AUTHORIZED TRAINED PERSONNEL DO THE FOLLOWING:**

#### **How to replace float switch, check ballast tanks, and vacuum motor. (See Figure 11)**

1. Remove the power cord from wall outlet.
2. Open the recovery tank/solution fill lid.
3. Using a Phillips screw driver, remove the retainer and the screw.
4. Perform the maintenance required.
5. Close recovery tank and reinstall latch and screw.

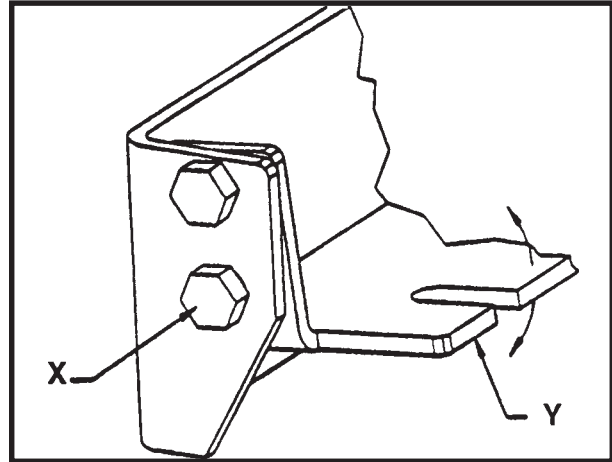

Figure 9

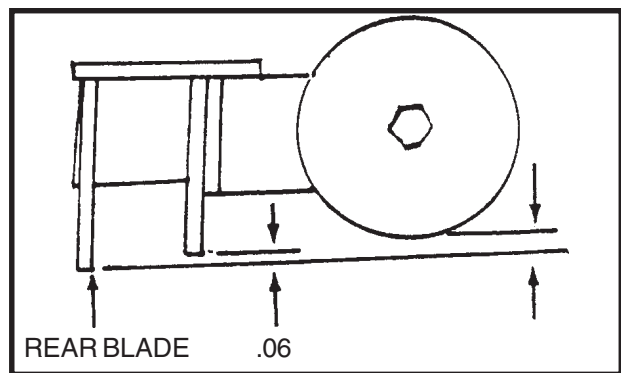

Figure 10

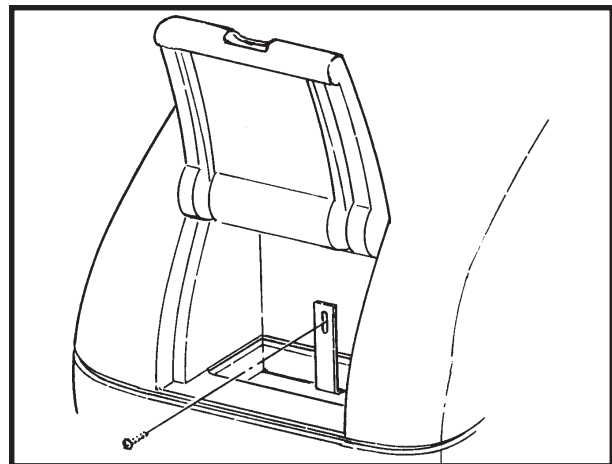

Figure 11

**Encore S20E 7/02**  
**Machine Variables and Accessories**

<b>115 Volt</b>	<b>00901A</b>	<i>Breakdown:</i>	00900A 51447D	Encore S20E 115V Base Machine 20" Polypropylene Brush
	<b>00902A</b>	<i>Breakdown:</i>	00900A 51453D	Encore S20E 115V Base Machine Pad Driver
<b>230 Volt</b>	<b>00911A</b>	<i>Breakdown:</i>	00910A 51447D	Encore S20E 230V Base Machine 20" Polypropylene Brush
	<b>00912A</b>	<i>Breakdown:</i>	00910A 51453D	Encore S20e 230V Base Machine Pad Driver

**Accessories**

<b>Description</b>	<b>Part No.</b>	<b>Pads by Case</b>	
Pad Driver, Dual Direction	51453D	<u>Color</u>	<u>20"</u>
Base	57370A	Yellow (Polish)	979199
Retainer	57369A	White (Polish)	976067
Pad/Brush Clutch Plate	66649A	Red, (Light Scrub)	976068
Spacer	58531A	Green, (Light Scrub)	976169
Clutch Plate Screws	962819	Blue, (Heavy Duty Scrub)	976069
Clutch Plate Nuts	80084A	Brown, (Stripper)	976070
Pad/Brush Clutch Plate Dual	30033A	Black, (Stripper)	976170
Spacer	58530A		
Poly Brush Dual Direction (general scrub)	51447D		
Nylon Brush .016 Dual Direction (general scrub)	51482D		
Clarke Care Kit	14607A		
Hour Meter Kit	10656A		
29" Squeegee Kit	18820A		
32" Squeegee Kit	10129A		
Polydur, Protectant	50478A		
Kit, Grease Gun	55420A		
Brake, Option	10635A		

**Clarke®  
Encore S20E  
Final Assembly Drawing 2/04**

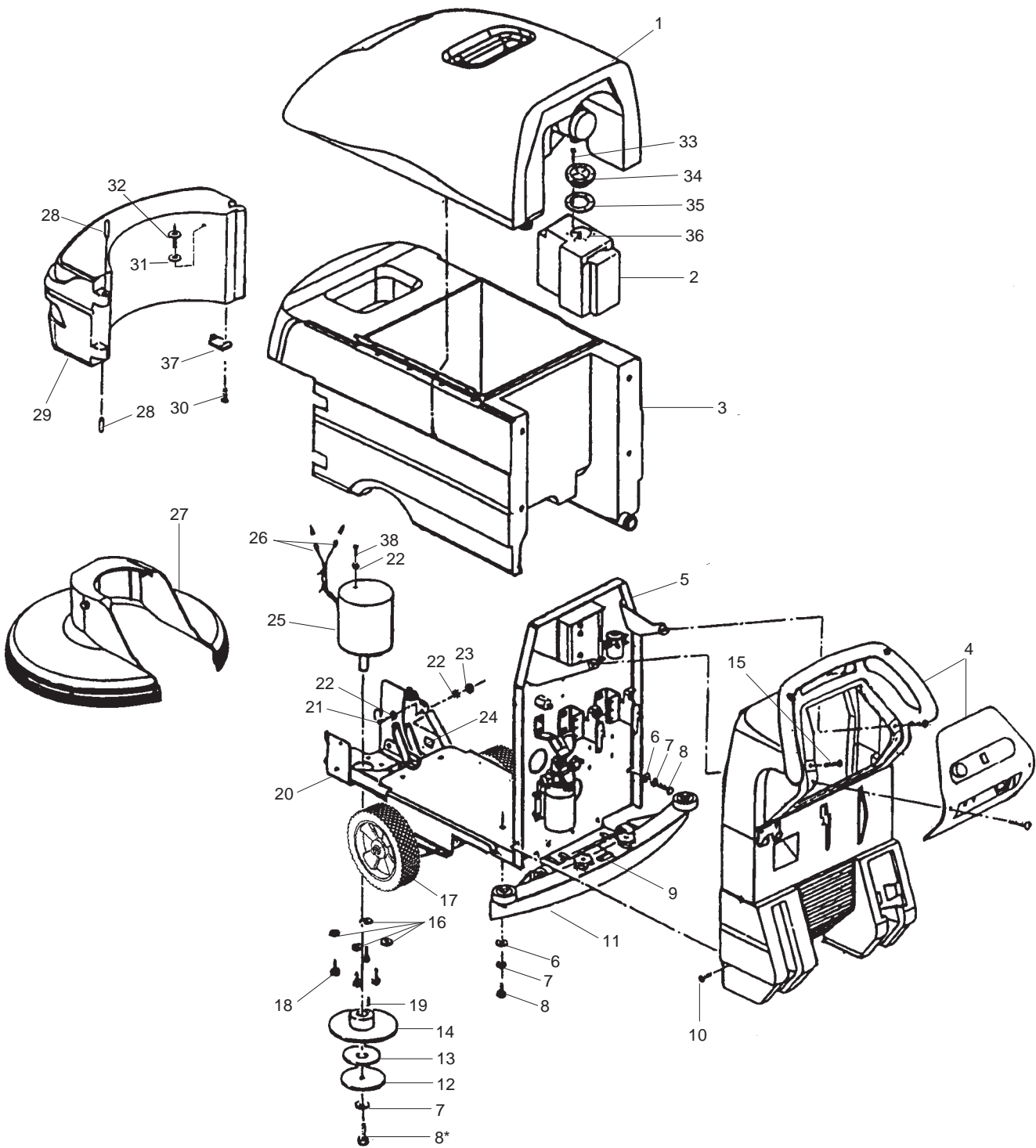

\*Recommended 12 foot pounds torque, also add blue loctite.

**Clarke®**  
**Encore S20E**  
**Final Assembly Parts List 2/04**

Ref #	Part No.	Description	115V Qty.	230V Qty.
1	See Pg 24	Tank Asm., Recovery	Ref.	Ref.
2	38817A	Tank, Ballast	2	2
3	See Pg 26	Tank Asm., Solution	Ref.	Ref.
4	See Pg 30	Cover Asm., Electrical	Ref.	Ref.
5	See Pg 28	Panel Asm., Rear	Ref.	Ref.
6	980651	Washer, Flat, <sup>5</sup> / <sub>16</sub>	8	8
7	980652	Washer, Lock, <sup>5</sup> / <sub>16</sub>	9	9
8	85811A	Screw, <sup>5</sup> / <sub>16</sub> -18 x <sup>3</sup> / <sub>4</sub>	9	9
9	See Pg 31	Lift Asm., Squeegee	Ref.	Ref.
10	85518A	Screw	6	6
11	See Pg 32	Squeegee Asm.	Ref.	Ref.
12	980210	Washer, Impeller	1	1
13	980679	Washer, Spacer, <sup>3</sup> / <sub>16</sub> x 1½ x <sup>1</sup> / <sub>8</sub>	1	1
14	20308A	Adaptor, Motor	1	1
15	85518A	Screw	2	2
16	980638	Washer, Lock, <sup>3</sup> / <sub>8</sub>	4	4
17	See Pg 34	Axle Asm.	Ref.	Ref.
18	85727A	Screw, <sup>3</sup> / <sub>8</sub> -16 x 1.0	4	4
19	80501A	Key, Shaft	1	1
20	See Pg 35	Lift Asm., Brush	Ref.	Ref.
21	962109	Screw	1	2
22	980603	Washer, Star	2	1
23	81110A	Nut	1	-
24	77094A	Label, Ground	1	1
25	44713A	Motor, Brush	1	-
	44711B	Motor, Brush	-	1
26	47710A	Terminal	2	2
27	See Pg 36	Housing Asm., Brush	Ref.	Ref.
28	36902A	Pins, Nylon	2	2
29	32403B	Cover, Front	1	1
30	85398A	Screw, <sup>1</sup> / <sub>4</sub> -20 x <sup>1</sup> / <sub>2</sub>	1	1
31	80255A	Washer, Nylon	1	1
32	80256A	Rivet, Plastic Anchor	1	1
33	84245A	Screw, 8-32 x <sup>3</sup> / <sub>4</sub> Flat	12	12
34	55673A	Lid, Gasket Tank	2	2
35	34291A	Gasket	2	2
36	81109A	Nut, 8-32 ESNA S.S.	12	12
37	65505A	Latch, Motor Cover	1	1
38	85832A	Screw, 10-32 x <sup>3</sup> / <sub>8</sub>	-	1
NI	See Pg 21	Brush or Pad Drivers	1	1
NI	See Pg 37	Parking Brake (Standard on 00900E and on 00910E)	1	1

Clarke®  
 Encore S20E  
 Recovery Tank Assembly Drawing 7/02  
 Drawing

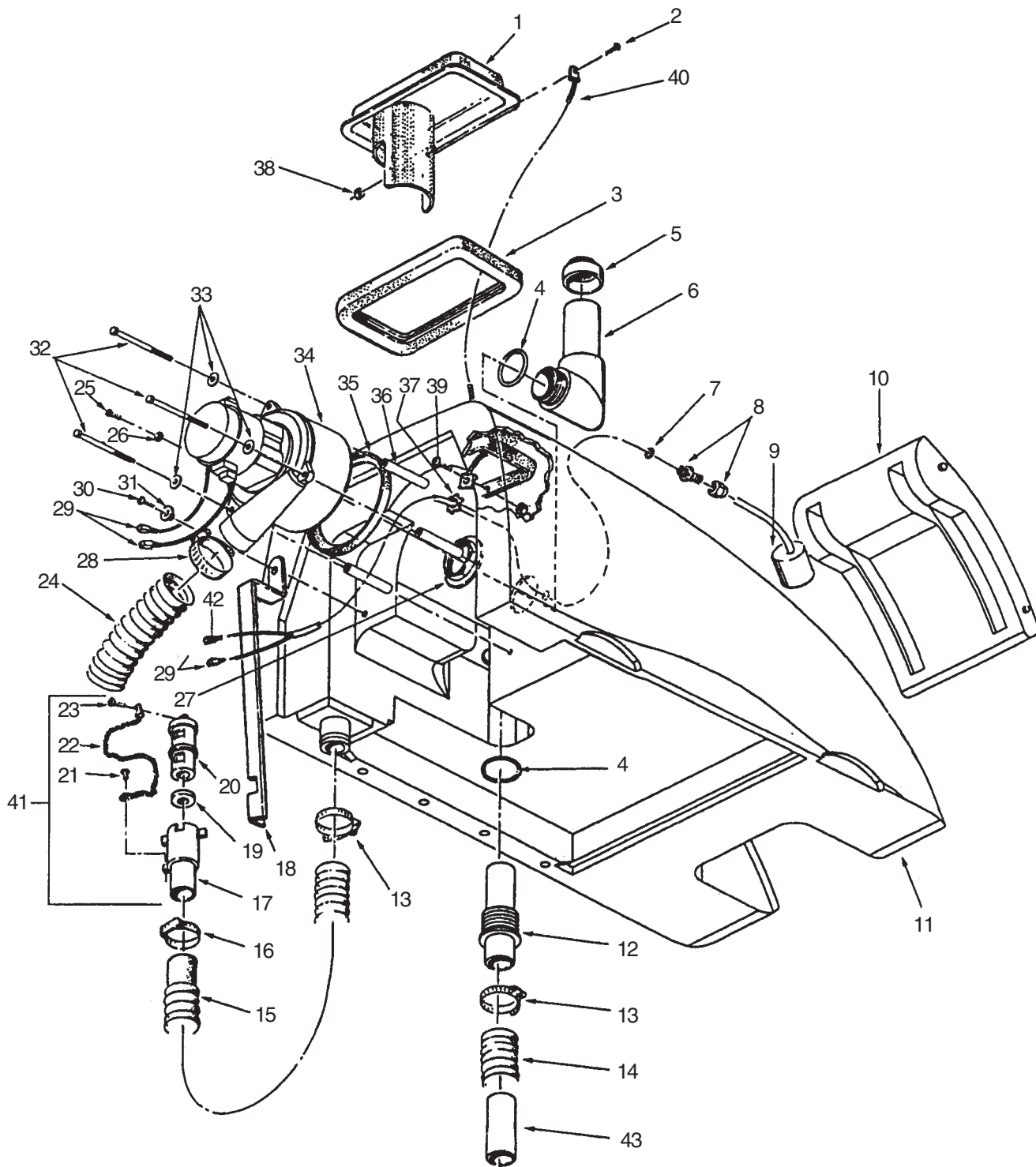



**Clarke®**  
**Encore S20E**  
**Recovery Tank Assembly Parts List 7/02**  
**Drawing #18121A - 115V**  
**Drawing #18122A - 230V**

Ref #	Part No.	Description	115V Qty.	230V Qty.
1	36209A	Lid	1	1
2	962798	Screw, 10-24 x ½ Pan	1	1
3	34256A	Gasket, Lid	1	1
4	837304	O-Ring	2	2
5	58069A	Strainer	1	1
6	39336A	Tube, Stand	1	1
7	59877A	Seal, Washer	1	1
8	56459A	Relief, Strain	1	1
9	47364B	Switch, Float (7,8,29,37 <u>not</u> included)	1	1
10	32401B	Lid, Fill, Solution	1	1
11	30251A	Tank, Recovery	1	1
12	30132A	Tube, Stand	1	1
13	752020	Clamp, Hose	2	2
14	824103	Hose, Squeegee	1	1
15	30443A	Hose, Drain	1	1
16	832002	Clamp	1	1
17	839401	Valve, Drain	1	1
18	65503A	Latch, Recovery	1	1
19	833407	Gasket, Drain	1	1
20	833901	Drain Valve Handle	1	1
21	962943	Screw, 8-18 x ½ PN	1	1
22	52206A	Chain	1	1
23	962987	Screw, 10-24 x ¾ Pan	1	1
24	674110	Hose	1	1
25	962546	Screw 10-24 x ½ Pan	1	1
26	980603	Washer, Star	1	1
27	920797	Nut	1	1
28	872010	Clamp, Hose	1	1
29	47905A	Terminal	3	3
30	962986	Screw, 5/16-18 x ¾	1	1
31	87621A	Washer, Shoulder Nylon	1	1
32	962950	Screw, ¼-20 x 3 Hex	3	3
33	87026A	Washer, Flat, ¼	3	3
34	44906A	Motor, Vac 120V	1	-
	44907A	Motor, Vac 230V	-	1
35	643418	Gasket	1	1
36	58534A	Spacer	3	3
37	82100A	Nut, Lock	1	1
38	81110A	Nut, 10-24 ESNA	1	1
39	85519A	Screw	1	1
40	692409	Chain	1	1
41	839410	Valve Asm. (includes Item#17,19, 20, 21, 22, 23)	1	1
42	47711A	Terminal, ¼ FIFQD 16/14	1	1
43	52337A	Sleeve, Hose	1	1

Clarke®  
Encore S20E  
Solution Tank Assembly Drawing 8/04

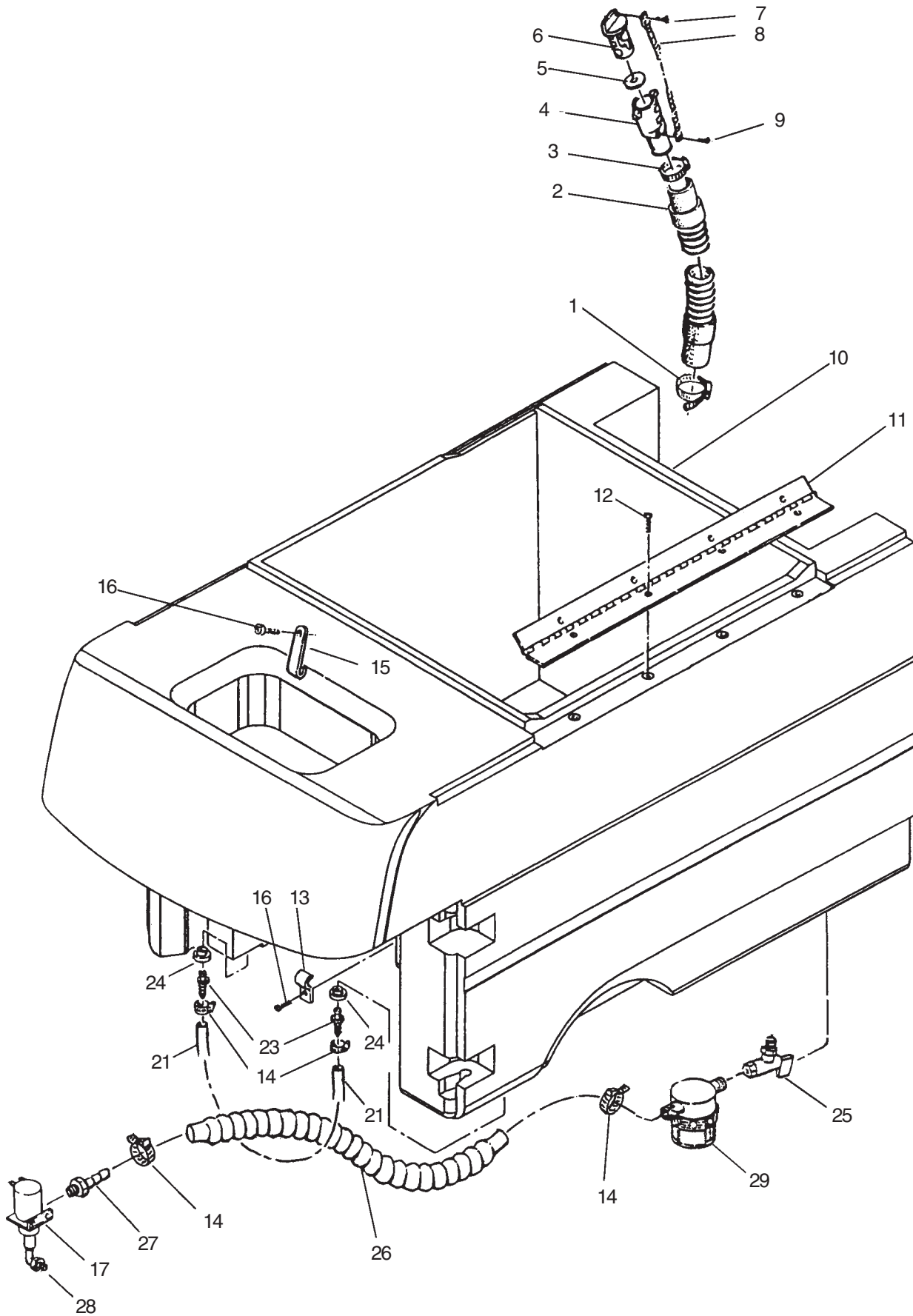

**Clarke®**  
**Encore S20E**  
**Solution Tank Assembly Parts List 8/04**

Ref #	Part No.	Description	Qty.
1	752020	Clamp	1
2	30442A	Hose, Drain	1
3	832002	Clamp	1
4	839401	Valve, Drain	1
5	833407	Gasket, Drain	1
6	833901	Drain Valve Handle	1
7	962987	Screw, 10-24 x <sup>3</sup> / <sub>6</sub>	1
8	52206A	Chain	1
9	962943	Screw, 8-18 x ½ PN	1
10	30250A	Tank, Solution	1
11	64517A	Hinge, Solution/Recovery	1
12	85398A	Screw, ¼-20 x <sup>5</sup> / <sub>8</sub>	4
13	782002	Clamp	1
14	50248A	Clamp, Hose	4
15	66989A	Latch, Retainer	1
16	84237A	Screw, 10-32 x ½	2
17	59610A	Valve, Flow, Electric (includes following)	1
	50389A	Plunger	1
	50390A	Spring	1
	50391A	Diaphragm, PTFE Vitron	1
21	30172A	Hose, Braided, .375 ID x 16½"	2
22	51205A	Adapter, Female	1
23	52414A	Connector Straight Hose/Tank	2
24	51518A	Bushing	2
25◆	51204A	Strainer	1
26	35138A	Hose, Solution	1
27	53619A	<sup>3</sup> / <sub>8</sub> x ¼ NPT Hosebarb	1
28	51526A	Hosebarb Elbow, 3/8 x 3/8	1
29◆	53562A	Filter, Bowl	1
NI	839410	Valve Asm.	-

(includes Item #4, 5, 6, 7, 8, 9)

◆53562A Components		
Clarke P/N	Description	Qty.
50081A	Bowl, Filter	1
53563A	Filter, Screen	1
53564A	Upper Body	1
54369A	Gasket, Bowl	1

NOTE: ◆ indicates a change has been made since the last publication of this manual.

Clarke®  
Encore S20E  
Rear Panel Assembly Drawing 7/02

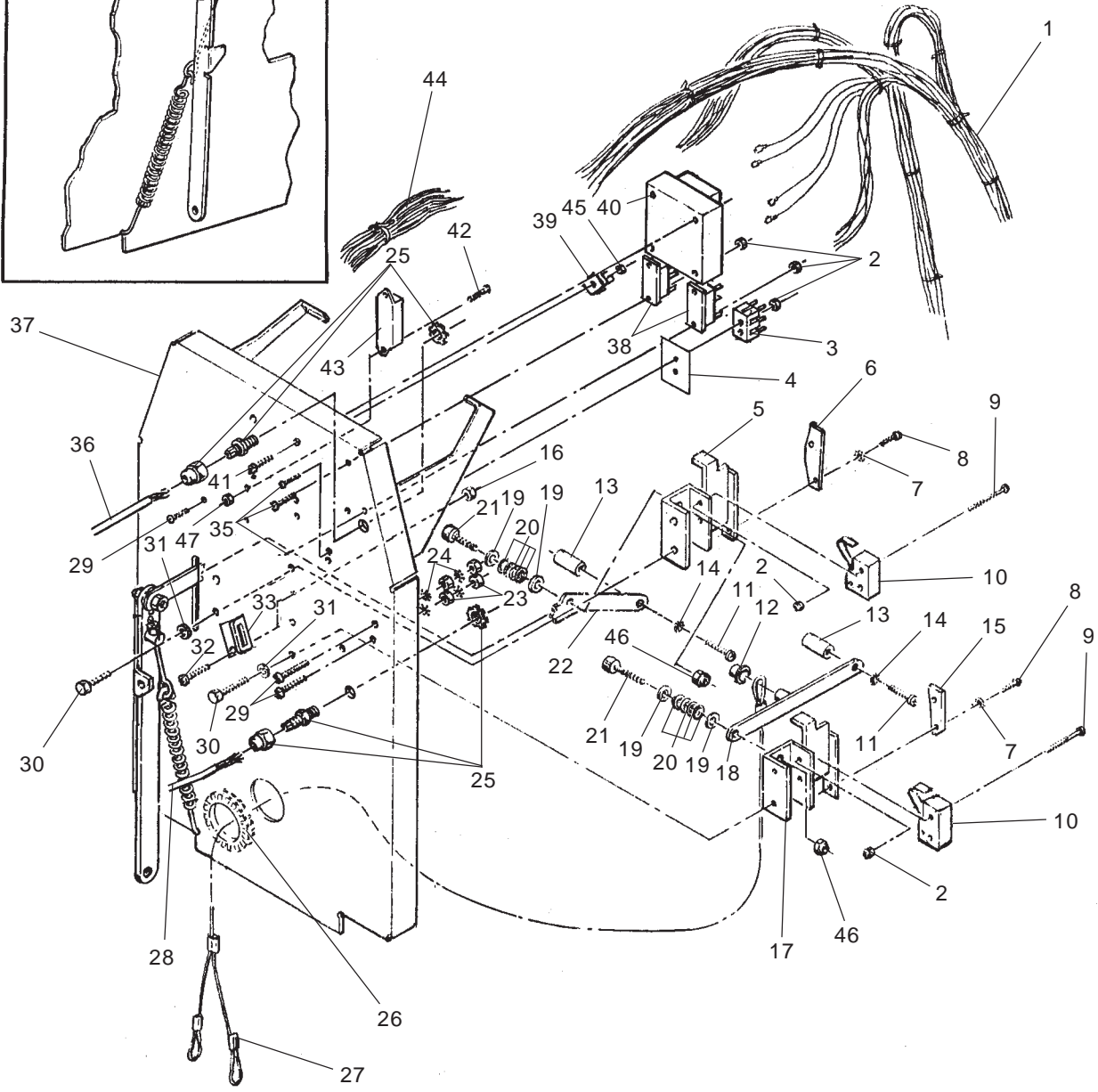
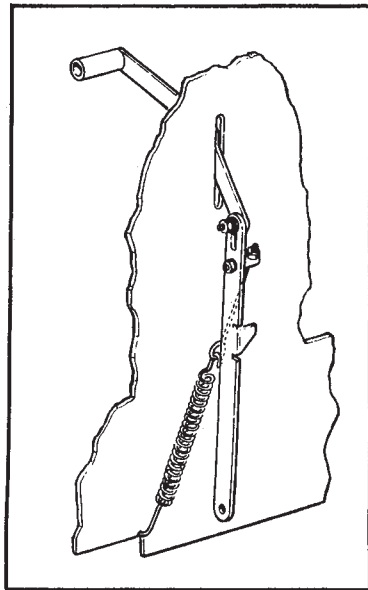

**Clarke®**  
**Encore S20E**  
**Rear Panel Assembly Parts List 7/02**

Ref #	Part No.	Description	115V Qty.	230V Qty.
1	49769A	Harness, Power	1	1
2	920056	Nut, 6-32	10	10
3	912059	Terminal, Block	1	1
4	43604A	Strip, Insulation	1	1
5	68789A	Lift , Brush	1	1
6	64238A	Plate, Wear, Lift, Brush	1	1
7	980603	Washer	4	4
8	962546	Screw, 10-24 x ½	4	4
9	85601A	Screw, 6-32 x 1¼ PN	4	4
10	47388A	Switch	2	2
11	85389A	Screw, ⅜-16 x ⅝	2	2
12	920346	Nut, Pal	1	1
13	64490A	Handle	2	2
14	980666	Washer, Starlock, ⅜	2	2
15	68643A	Plate, Wear, Vac	1	1
16	81104A	Nut, ¼-20	14	14
17	61260A	Squeegee Lift Plate	1	1
18	64901A	Handle, Lift, Squeegee	1	1
19	980692	Washer, Flat, ⅝ SS	4	4
20	438360	Spring	2	2
21	80028A	Bolt, Shoulder, ⅝ <sub>16</sub> x 1.0	2	2
22	64498A	Handle, Lift, Brush	1	1
23	920224	Nut, 10-32 Hex	4	4
24	980603	Washer, Star	4	4
25	53018A	Stain Relief	2	2
26	54606A	Grommet, Slotted, 7.75"	1	1
27	61677A	Cable, Lift, Squeegee	1	1
28	49767A	Cord, Brush/Sol	1	-
	49767B	Cord, Brush/Sol	-	1
29	85383A	Screw, 10-32 x ¾ Pan	3	3
30	170915	Screw, ¼-20 x ¾ Hex	4	4
31	980657	Washer, Lock, ¼	4	4
32	85391A	Screw, ¼-20 x ⅝	2	2
33	69858A	Latch, Tank, Recovery	1	1
35	962212	Screw, 6-32 x ⅞	6	6
36	49768A	Cord, Vac/Float	1	1
37	68790A	Panel, Rear	1	1
38	41816A	Contacto	2	2
39	46106A	Rectifier, Bridge	1	1
40	41148A	Convertor, Power	1	-
	41149A	Convertor, Power	-	1
41	85307A	Screw 10-32 x ⅝	4	4
42	85612A	Screw, 10-24 x ⅝	-	2
43	47201A	Suppressor, RF	-	1
44	49788A	Harness, Suppressor	-	1
45	920722	Nut, 10-32 ESNA	1	1
46	81217A	Nut, ¼-20 x .218 Nylock	2	2
47	81110A	Nut, 10-24 Nylock	-	2
NI	47704A	Terminal, FIMOD	-	2
NI	77094A	Label, Ground	1	1

**Clarke®**  
**Encore S20E**  
**Electrical Cover Assembly Drawing and Parts List 7/02**  
**Drawing #18118A - 115V**  
**Drawing #18120A - 230V**

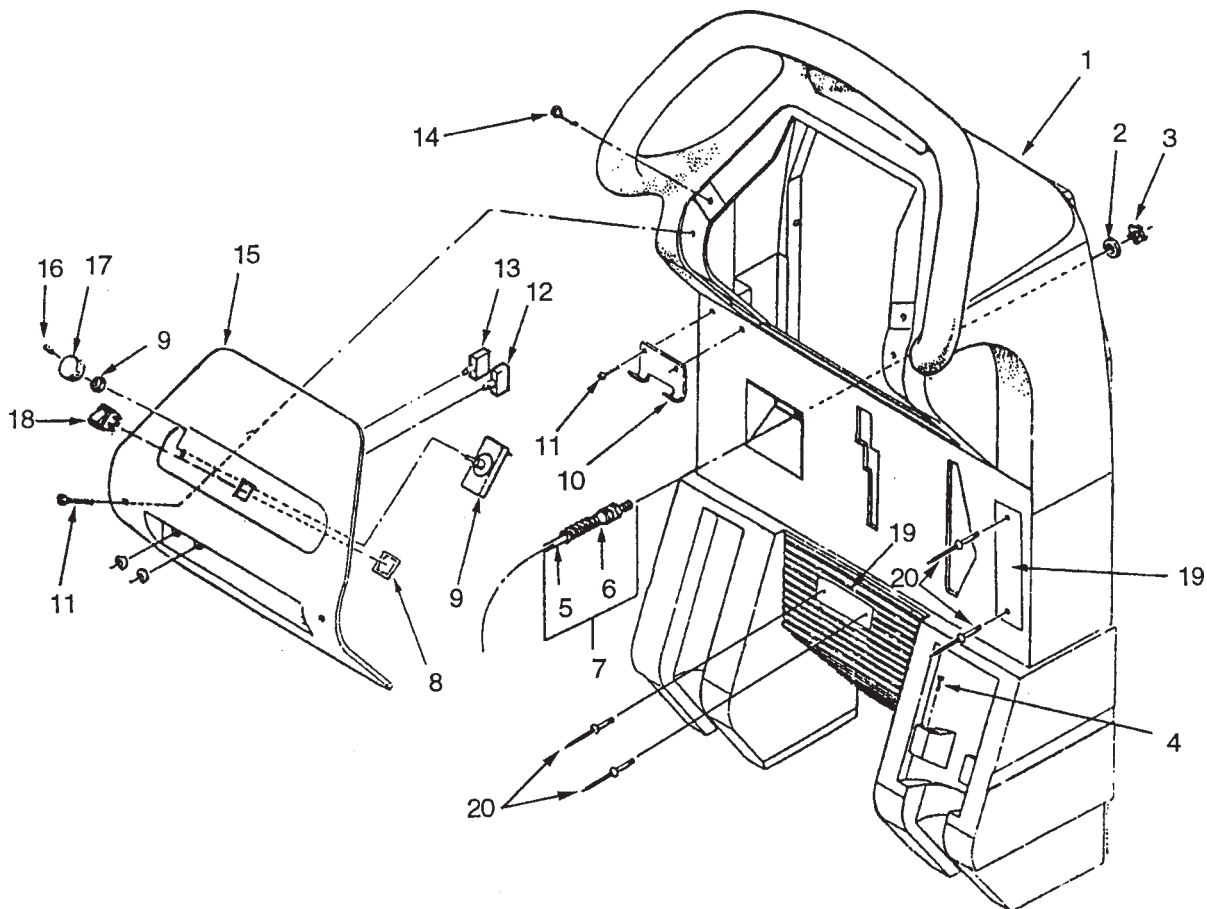

Ref #	Part No.	Description	115V Qty.	230V Qty.
1	30254A	Cover, Rear	1	1
2	170870	Washer	1	1
3	82100A	Nut, Conduit	1	1
4	962957	Screw	2	2
5	42205B	Cord, Power	1	-
	42232A	Cord, Power	-	1
6	467504	Relief, Strain	1	-
	58013A	Relief, Strain	-	1
7	40003A	Cord, Asm. Power (Includes #'s 5 & 6)	1	-
	42086A	Cord, Asm. Power (Includes #'s 5 & 6)	-	1
8	50766A	Clip, Retainer	1	1
9	44308B	Control, Solution Flow	1	1
10	66987A	Hanger, Hose	1	1
11	84237A	Screw	4	4
	41447A	Breaker, Circuit Transformer 0.5	1	1
12	41418B	Breaker, Circuit Brush 10A	1	-
	41437A	Breaker, Circuit Brush 5A	-	1
14	85518A	Screw, 1/4-20 x 3/4	2	2
15	32407A	Control Panel	1	1
16	962262	Screw, Set 8-32 (Included with #17)	2	2
17	55502A	Knob	1	1
18	47316B	Switch, Main	1	1
19	70079A	Plate, Warning (with brake)	1	2
	70080A	Plate Warning (without brake)	1	2
20	83010A	Rivet	2	4

**Clarke®**  
**Encore S20E**  
**Squeegee Lift Assembly Drawing and Parts List 10/03**  
**Drawing # 18814A**

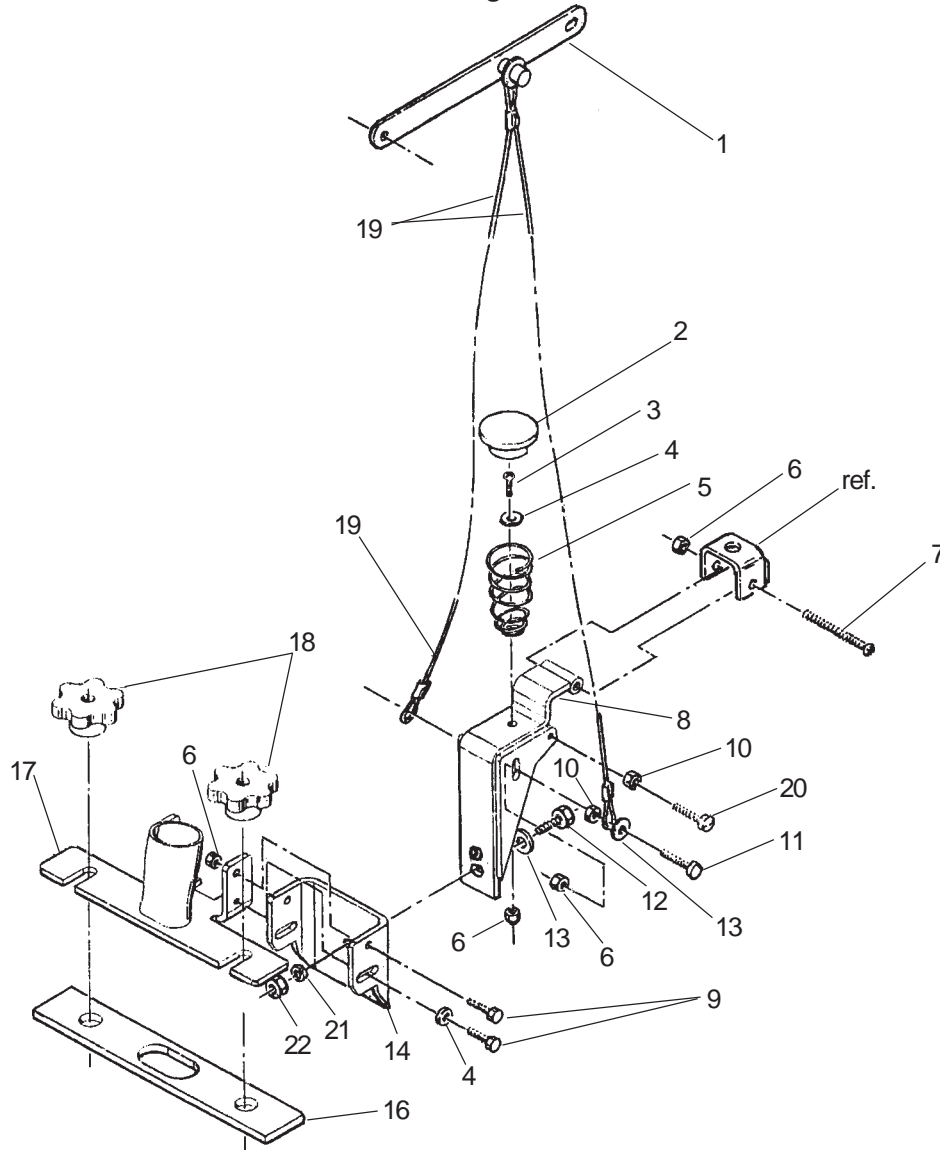

Ref #	Part No.	Description	Qty.
1	Pg 26, Ref 18	Handle	-
2	30517A	Bushing	1
3	85600A	Screw, 1/4-20 x 3/4	1
4	87026A	Washer, 1/4, SS	3
5	50034A	Spring, Squeegee	1
6	81104A	Nut, Nylock, 1/4	6
7	85396A	Screw, 1/4-20 x 2 SS	1
8	60225A	Swivel, Squeegee	1
9	170915	Screw, 1/4-20 x 3/4	4
10	920208	Nut, 1/4-20, Plated	4
11	962481	Screw, 1/4-20 x 1 1/4 Hex	2
12	85727A	Screw, 3/8-16, Hex	1
13	87031A	Washer, Flat, 3/8, SS	3
14	69860B	Pin, Bracket	1
16	34260B	Gasket, Squeegee	Ref.
17	61263A	Bracket, Tube	1
18	25201A	Knob, Clamping	Ref.
19	61677A	Cable, Lift, Squeegee	Ref.
20	86408A	Screw, 1/4-20x1 Hex	2
21	980638	Lockwasher	1
22	81111A	Nut	1

**Clarke®**  
**Encore S20E**  
**Squeegee Assembly Drawing and Parts List 8/04**  
**29" Asm. - 18820A (Optional)**  
**33" Asm. - 18821A (discontinued, use 10129A)**

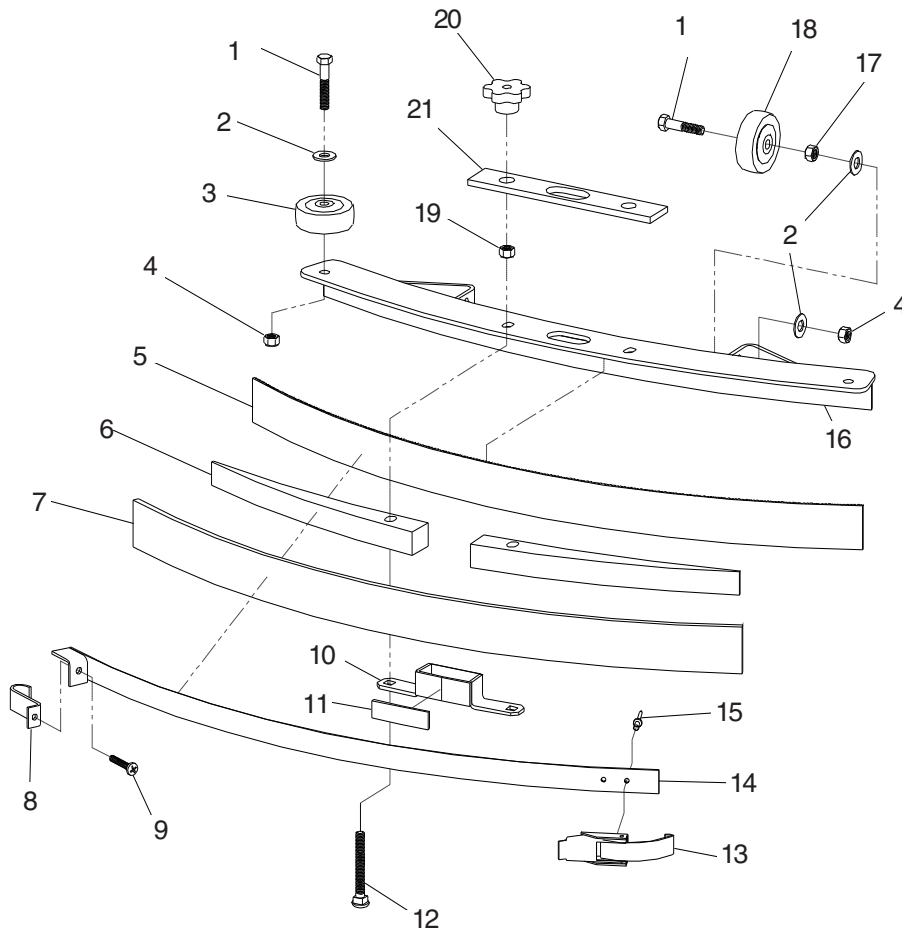

Ref #	Part No.	Description	29"	33"
1	962522	Screw, $\frac{3}{8}$ -16 x 2" Hex	4	4
2	980687	Washer, $\frac{15}{32}$ I.D. x $\frac{15}{16}$ O.D.	6	6
3	59950A	Wheel, Guide	2	2
4	81111A	Nut, $\frac{3}{8}$ -16 ESNA	4	4
5	30950A	Blade, Ribbed, Urethane	-	1
	30951A	Blade, Ribbed, Urethane	1	-
6	38713A	Spacer, 29"	2	-
	38719A	Spacer, 33"	-	2
7	30931A	Blade, Rubber, Outer	1	-
	30946A	Blade, Rubber, Outer	-	1
8	62421A	Clamp, End	1	1
9	86004A	Screw, $\frac{1}{4}$ -20 x $1\frac{1}{2}$ Hex	1	1
10	62712A	Duct, Squeegee Inlet	1	1
11	37016A	Pad, Squeegee Grip	1	1
12	80011A	Screw, $\frac{3}{8}$ -16 x 3 CR S.S.	2	2
13	55722A	Latch, Squeegee Strap	1	1
14	62441A	Clamp, Squeegee 29"	1	-
	62445A	Clamp, Squeegee 33"	-	1
15	170932	Rivet, Pop 3.16 S.S. $\frac{1}{8}$ "	2	2
16	69059A	Squeegee Weldment 29"	1	-
	69672A	Squeegee Weldment 33"	-	1
17	81207A	NUt, $\frac{3}{8}$ -16 S.S.	2	2
18	419702	Wheel	2	2
19	81301A	Nut, $\frac{3}{8}$ -16 Jam S. S.	2	2
20	25201A	Knob	2	2
21	34260B	Gasket	1	1

**Optional:**

NI	30938A	Nitrile 29" Outer Blade
NI	30949A	Nitrile 33" Outer Blade
NI	30930A	Rubber 29" Inner Blade
NI	30947A	Rubber 33" Inner Blade
NI	30955A	Urethane 29" Inner Notched $\frac{1}{16}$ "
NI	30956A	Urethane 33" Inner Notched $\frac{1}{16}$ "

NOTE: ♦ indicates a change has been made since the last publication of this manual.



**Clarke®**  
**Encore S20E**  
**Squeegee Assembly Drawing 6/04**  
**Drawing # 10068A and 10129A (used on machines built after 4-8-03, starting with Serial # AC2077)**

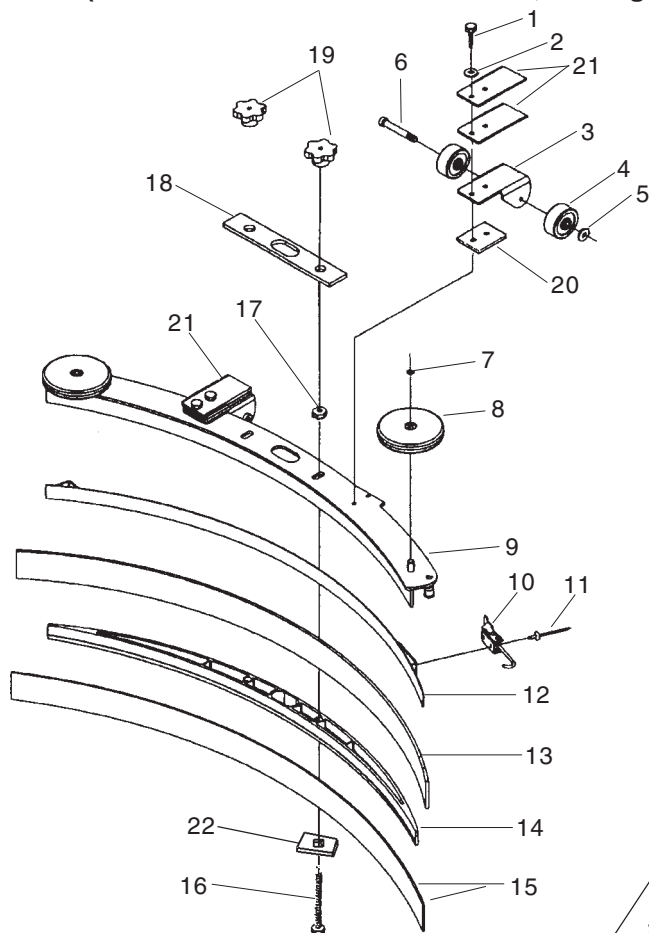

Ref. #	Part No.	Description		
			39" Qty	32" Qty
1	80252A	Screw, ¼-20 x 1 Hex SS	-	4
	80253A	Screw, ¼-20 x 1½ Hex SS	4	-
2	980657	Washer, ¼ Lock	4	4
	60243A	Bracket, Squeegee Wheel	2	2
4	30049B	Wheel, Squeegee	4	4
5	81104A	Nut, ¼-20	2	2
6	60254A	Bolt, Shoulder 5/16x 2¼	2	2
7	50958A	Ring, 3/8 ID Snap	2	2
8	30048A	Wheel, Guide, 4 Inch Diameter	2	2
	60272A	Channel, Squeegee Weldment 39"	1	-
9	60234A	Channel, Squeegee Weldment 32"	-	1
	50835A	Latch, Squeegee Clamp	1	1
11	930086	Rivet, 3/16 x .450 Aluminum	2	2
12	60252A	Strap, Clamp, Squeegee Retainer 39"	1	-
	60232A	Strap, Clamp, Squeegee Retainer 32"	-	1
13	30069A	Blade, Rear, Gum Rubber, 39"	1	-
	30067A	Blade, Rear, Gum Rubber, 32"	-	1
14	30058A	Spacer, Squeegee 39"	1	-
	30047A	Spacer, Squeegee 32"	-	1
15	30091A	Blade, Front Ribbed 39"	1	-
	30066A	Blade, Front Ribbed 32"	-	1
16	80011A	Screw, 3/8-16 x 3	2	2
17	81301A	Nut, 3/8-16 Jam SS	2	2
18	34260B	Gasket	1	1
19	25201A	Knob	2	2
20	60358A	Shim, Squeegee Wheel	2	2
21	61370A	Weight	8	4
22	80280A	Nut, Squeegee Backup	2	2

Clarke®  
 Encore S20E  
 Frame Assembly Drawing and Parts List 10/03  
 Drawing # 16927A

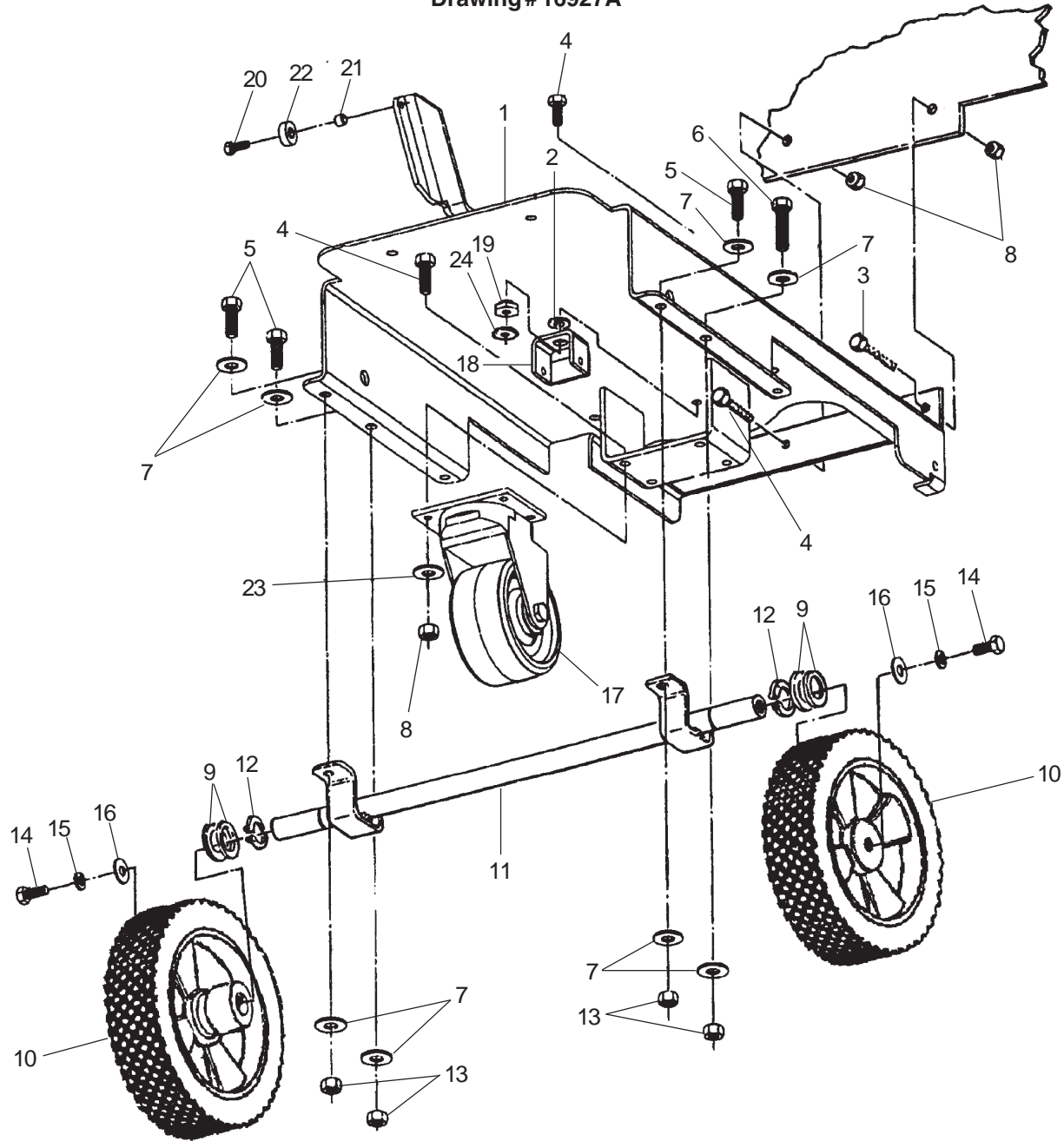

Ref #	Part No.	Description	Qty.
1	63431A	Frame Weldment	1
2	87607A	Washer, Nylon	1
3	85814A	Screw, $\frac{5}{16}$ -18 x $1\frac{1}{4}$	1
4	85811A	Screw, $\frac{5}{16}$ -18 x $\frac{3}{4}$	7
5	85727A	Screw, $\frac{3}{8}$ -16 x 1	3
6	85836A	Screw, $\frac{3}{8}$ -16 x 2	1
7	87031A	Washer, Flat, $\frac{3}{8}$ , SS	8
8	920110	Nut, $\frac{5}{16}$ -18 ESNA	7
9	87616A	Washer	4
10	61436B*	Wheel, Non-Traverse	2
11	60535A	Axle, Non-Traverse	1

Ref #	Part No.	Description	Qty.
12	57423A	Ring, Retainer	2
13	81105A	Nut, $\frac{3}{8}$ -16 ESNA	4
14	962620	Screw, Hex, $\frac{5}{16}$ -24 x $\frac{3}{4}$	3
15	980652	Washer, Lock, $\frac{5}{16}$	2
16	980205	Washer	2
17	61675A	Caster	1
18	61252A	Bracket, Squeegee	1
19	61433A	Nut, Spacer	1
20	85391A	Screw, $\frac{1}{4}$ -20 x $\frac{5}{8}$	1
21	608210	Spacer, Bolt	1
22	51516A	Bushing	1
23	980651	Washer, Flat, Plated, $\frac{5}{16}$	4
24	81112A	Nut, $\frac{5}{16}$ ESNA Thin SS	1

\*used on machines built after 8-26-03, starting w/  
 Serial #BH2415

**Clarke®**  
**Encore S20E**  
**Brush Lift Assembly Drawing and Parts List 2/04**  
**Drawing #60208A**

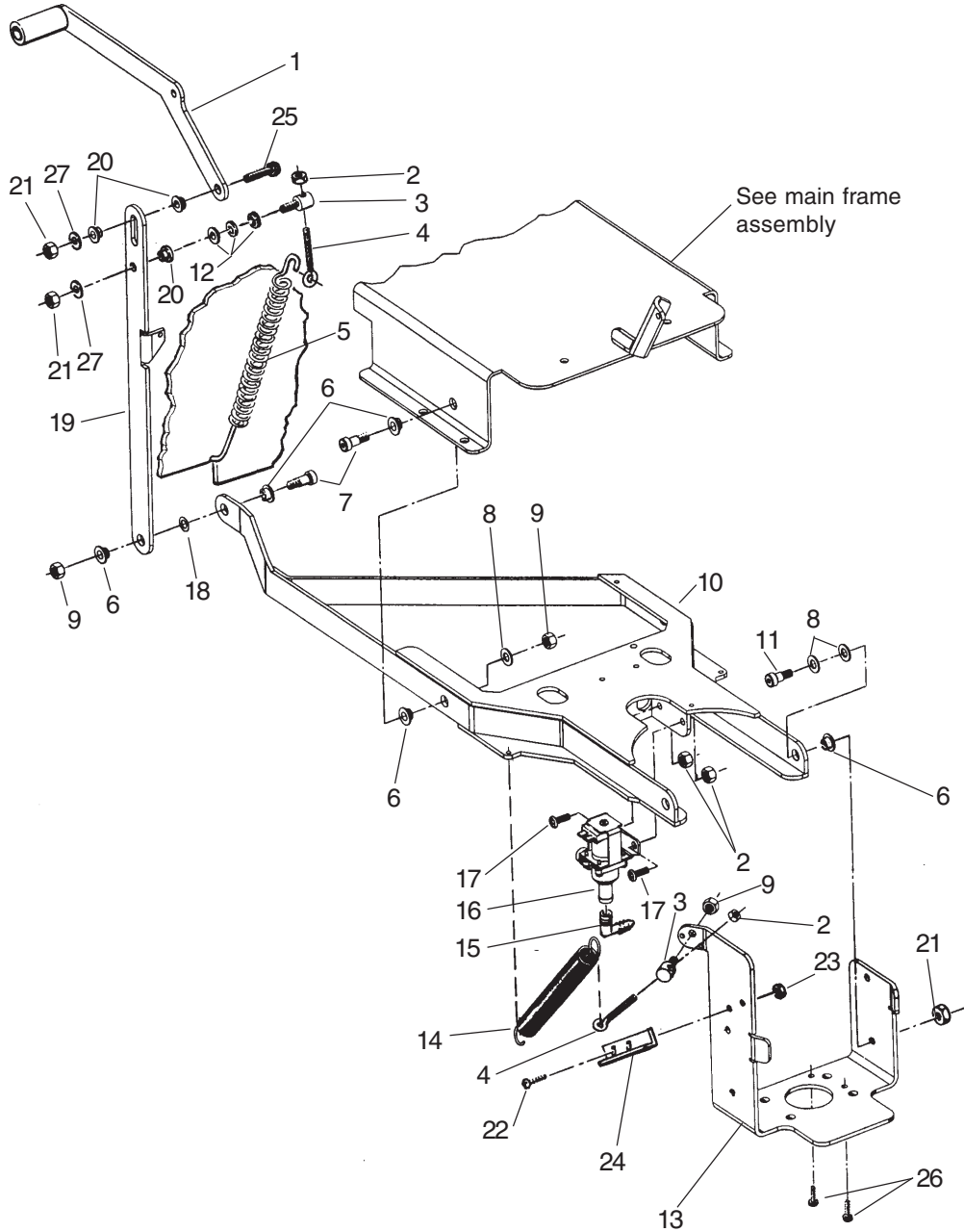

Ref #	Part No.	Description	Qty.	Ref #	Part No.	Description	Qty.
1	Ref.	Handle, Lift, Brush	-	15	51526A	Hosebarb	1
2	81104A	Nut, 1/4-20 ESNA	4	16	59610A	Valve, Solution	Ref
3	848508	Swivel, Rod, Brake	2	17	85391A	Screw, 1/4-20 x	2
4	80042A	Screw, Eye, Adjustment	2	18	87619A	Washer, 375032	1
5	50291A	Spring, Pressure	1	19	60207A	Link, Brush Lift	1
6	87620A	Washer, Shoulder,	8	20	87621A	Washer, 3001	3
7	80041A	Bolt, Shoulder, 3/8 x 1/2	3	21	81112A	Nut, 5/16-18 Thin ESNA SS	4
8	87618A	Washer	6	22	962798	Screw 10-24 x 1/2	2
9	920181	Nut, 5/16, ESNA	4	23	81110A	Nut 10-24	2
10	63432A	Frame, Brush Lift	1	24	64239A	Plate, Deflector	1
11	80040A	Bolt, Shoulder, 3/8 x 3/8	2	25	85812A	Screw, 5/16-18 x 7/8	1
12	980651	Washer	3	26	962554	Screw, 1/4-28 x 1/2	2
13	69861A	Bracket, Motor, Brush	1	27	980692	Washer, 5/16 S.S. Flat	2
14	56493A	Spring	1				

Clarke®  
 Encore S20E  
 Brush Housing Assembly Drawing and Parts List 7/02  
 Drawing # 11447A

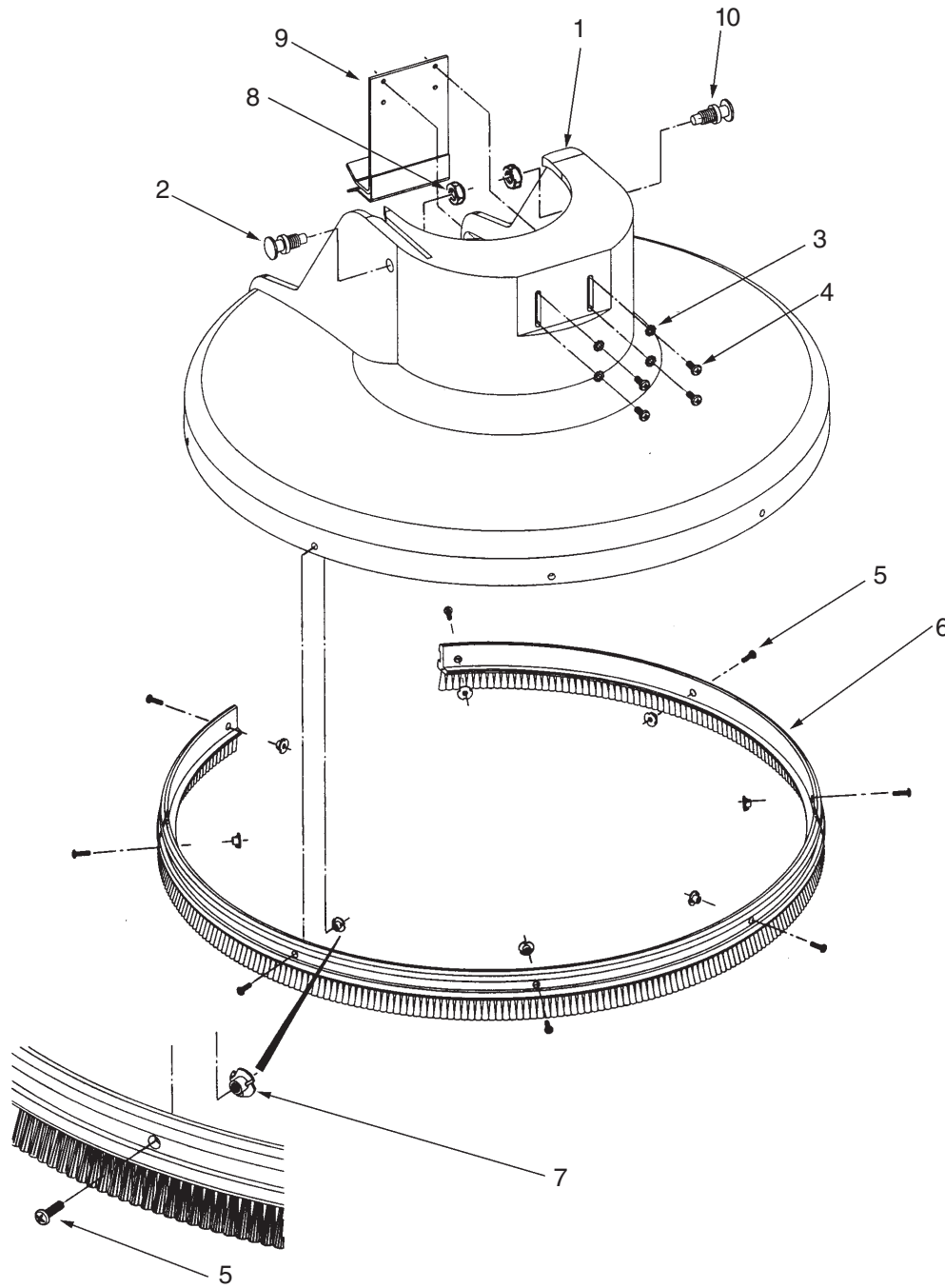

Ref #	Part No.	Description	Qty.
1	30255A	Housing, Brush	1
2	636706	Pin	1
3	980603	Washer	4
4	962798	Screw, 10-24 x 1/2	4
5	84237A	Screw, 10-32 x 1/2	8
6	38241A	Skirt, Fibers	1
7	82004A	Nut, 10-32 "T"	8
8	920278	Nut, 1/2-20 S.S. Jam	2
9	62438A	Bracket, Stop, Housing, Brush	1
10	66550A	Pin	1

**Clarke®**  
**Encore S20E**  
**Brake Drawing and Parts List 7/02**  
**PN 10635A**

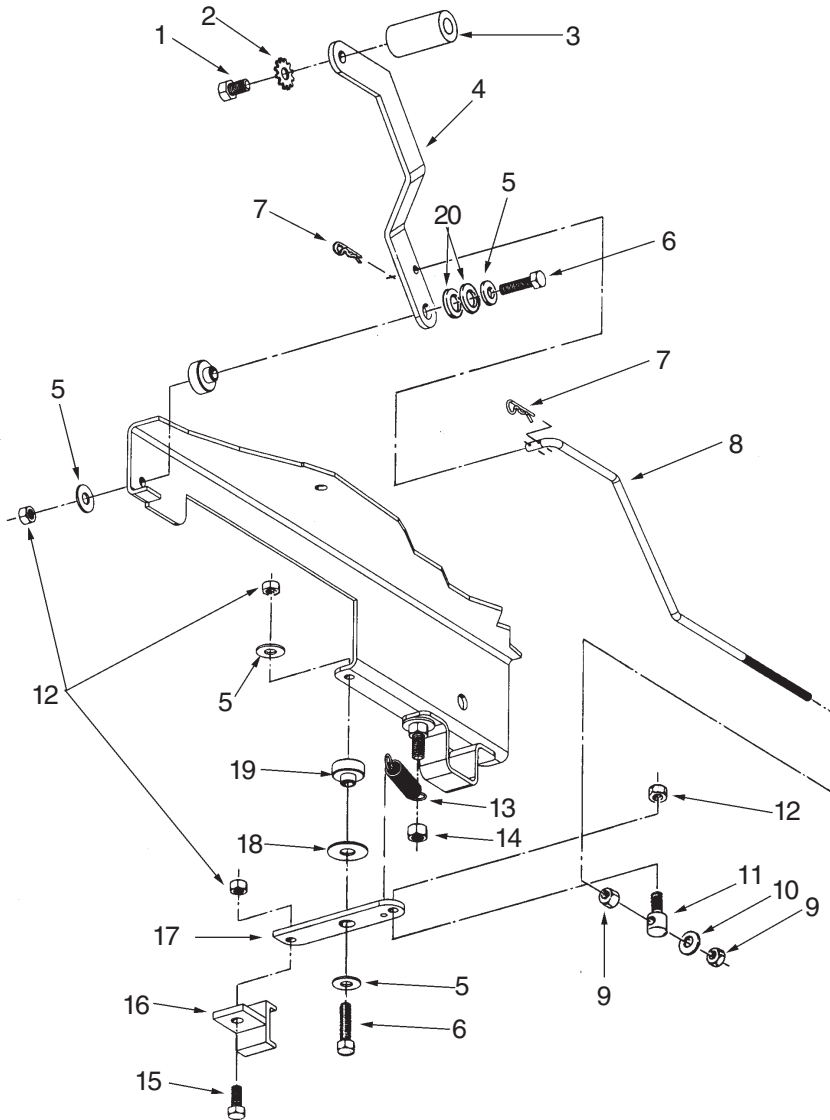

Ref #	Part No.	Description	Qty.
1	85389A	Screw, $\frac{3}{8}$ -16 x $\frac{5}{8}$	1
2	980666	Washer, Starlock, $\frac{3}{8}$	1
3	64490A	Handle	1
4	65627A	Brake, Lever	1
5	980651	Washer, Flat, $\frac{5}{16}$	4
6	85814A	Screw, $\frac{5}{16}$ -18 x $1\frac{1}{4}$	2
7	836711	Clip	2
8	67161A	Rod, Brake	1
9	81104A	Nut, $\frac{1}{4}$ -20 ESNA	2
10	87026A	Washer, Flat, $\frac{1}{4}$	1
11	848508	Swivel, Rod, Brake	1
12	920110	Nut, $\frac{5}{16}$ -18 ESNA	4
13	848302	Spring, Arm, Brake	1
14	81105A	Nut, $\frac{3}{8}$ -16 ESNA	1
15	85811A	Screw, $\frac{5}{16}$ -18 x $\frac{3}{4}$	1
16	66212A	Pad, Brake	1
17	60451A	Bar, Brake	1
18	87607A	Washer, Flat, Nylon, $\frac{1}{2}$	1
19	67877A	Spacer	2
20	980673	Washer	2

**Clarke®**  
**Encore S20E**  
**115V Vacuum Motor**  
**Drawing and Parts List 7/02**  
**Form # 44906A**

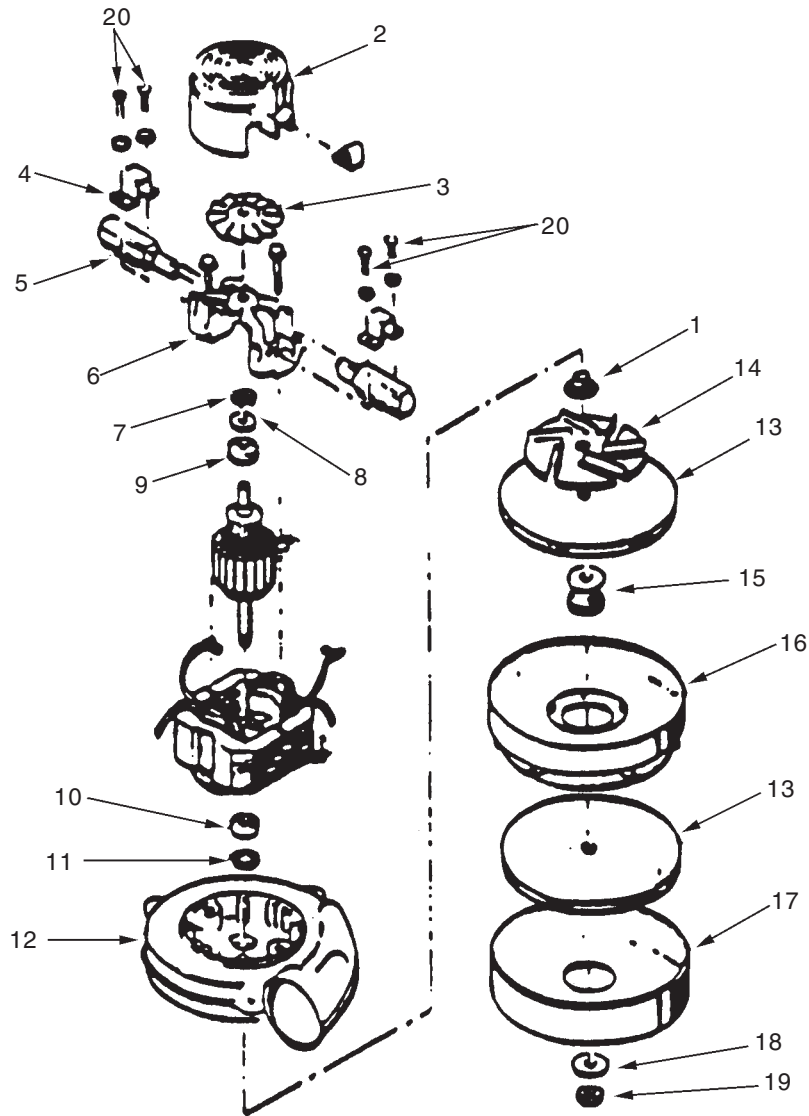

Ref #	Part No.	Description	Qty
1	58501A	Spacer	1
2	54809A	Housing-Vent	1
3	53905A	Fan	1
4	51914A	Clamp	2
5	51419A	Carbon Brushes 115V	2
6	50618A	Commutator End Bracket	1
7	638313	Load Spring	1
8	53100A	Disc	1
9	902679	Ball Bearing	1
10	902648	Ball Bearing	1

Ref #	Part No.	Description	Qty
11	59803A	Neoprene Washer	1
12	50610A	Fan End Bracket	1
13	53914A	Vacuum Fan	2
14	53906A	Fan	1
15	658201	Spacer	1
16	53908A	Stationary Fan	1
17	57904A	Fan Shell	1
18	980205	Washer	1
19	920329	Nut	1
20	85303A	Screw, <sup>3</sup> / <sub>8</sub> -32	4

**Clarke®**  
**Encore S20E**  
**230V Vacuum Motor**  
**Drawing and Parts List 7/02**  
**Form # 44907A**

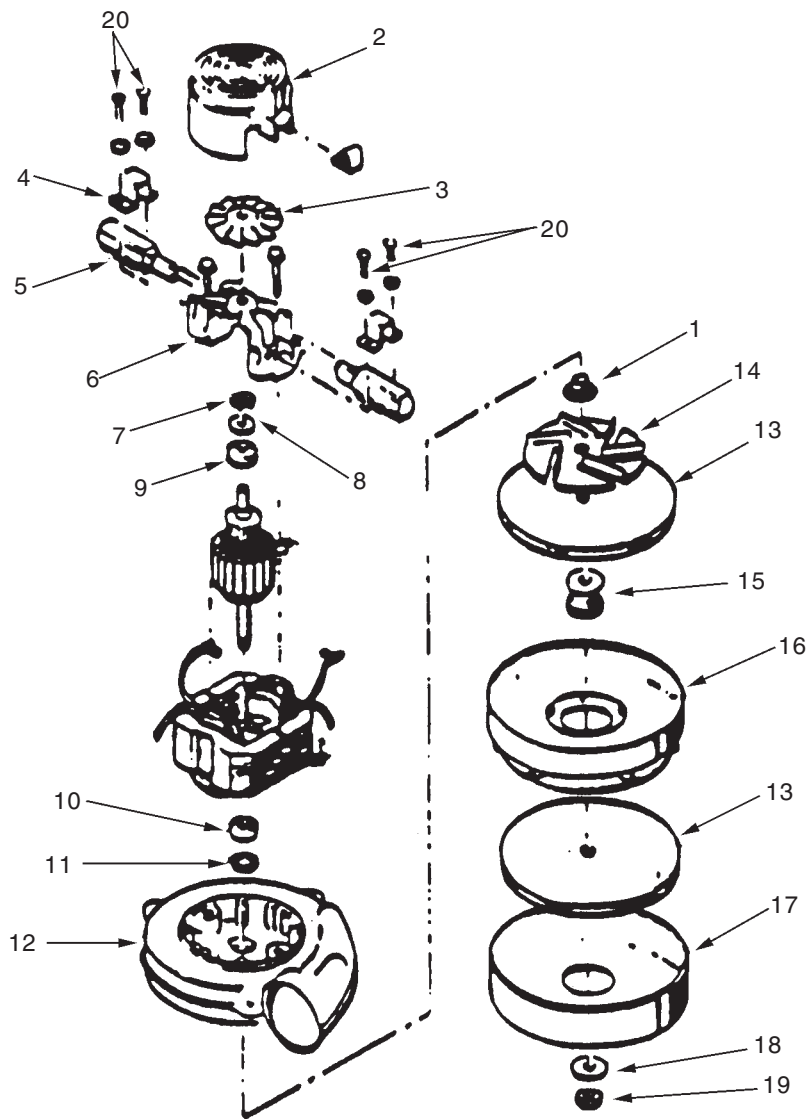

Ref #	Part No.	Description	Qty
1	58501A	Spacer	1
2	54809A	Housing-Vent	1
3	53905A	Fan	1
4	51914A	Clamp	2
5	51401A	Carbon Brushes 230V	2
6	50618A	Commutator End Bracket	1
7	638313	Load Spring	1
8	53100A	Disc	1
9	902679	Ball Bearing	1
10	902648	Ball Bearing	1

Ref #	Part No.	Description	Qty
11	59803A	Neoprene Washer	1
12	50610A	Fan End Bracket	1
13	53914A	Vacuum Fan	2
14	53906A	Fan	1
15	658201	Spacer	1
16	53908A	Stationary Fan	1
17	57904A	Fan Shell	1
18	980205	Washer	1
19	920329	Nut	1
20	85303A	Screw, 3/8-32	4

**Clarke®**  
**Encore S20E**  
**Gearbox Assembly Drawing and Parts List 7/02**  
**Form #54238A**

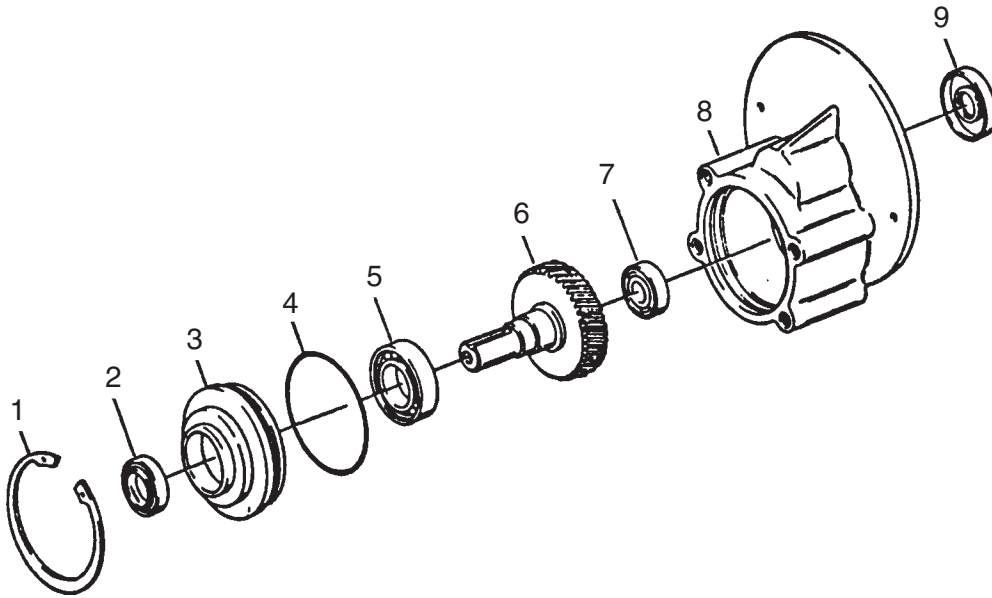

Ref #	Part No.	Description	Qty
1	57846A	Ring, Snap	1
2	58143A	Seal, Oil, Small	1
3	52050A	Cap End	1
4	56668A	O-Ring	1
5	51176a	Bearing, Large	1
6	58316A	Shaft & Gear	1
7	902605	Bearing, Small	1
8	54883A	Housing	1
9	58144A	Seal, Oil Large	1
10	NI	Darina EP2 Grease	4 oz.



**Clarke®**  
**Encore S20E**  
**Motor and Gearbox Assembly**  
**Drawing and Parts List 7/02**  
**Form # 44713A-115V**  
**Form # 44711A-230V**  
**Form 44711B-230V**

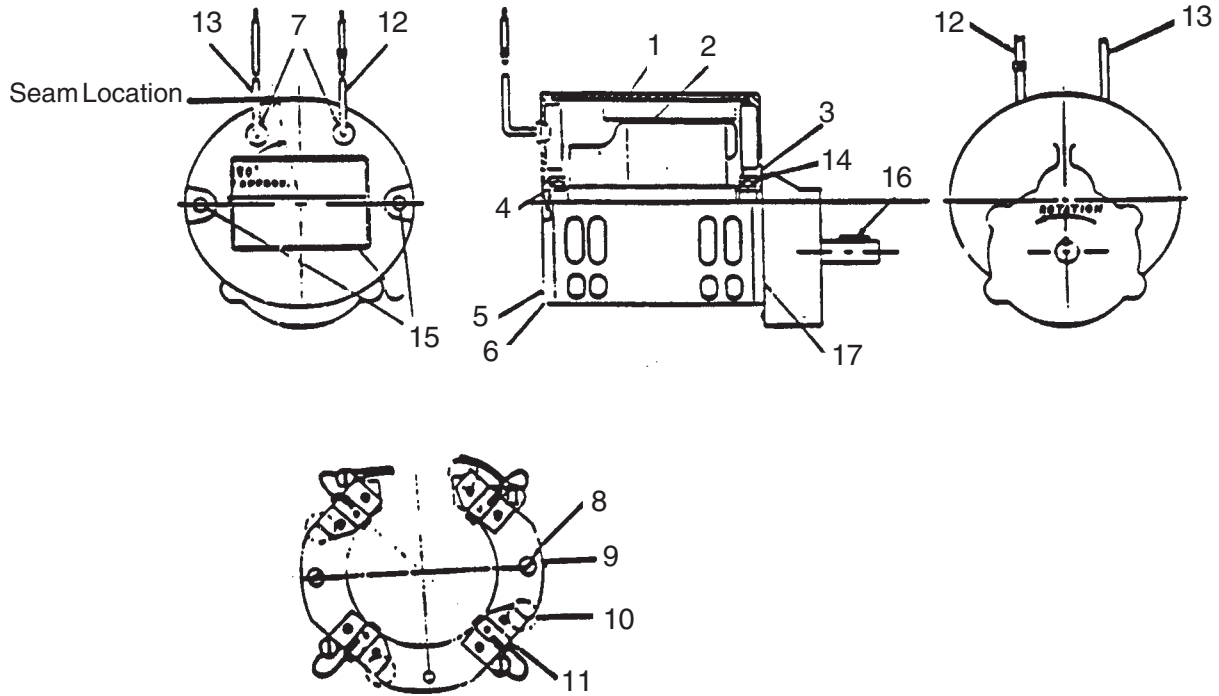

Item	Part No.	Description	115v Qty	230v Qty.
1	56477A	Stator Frame Assembly (w/Magnets & Clips)	1	1
2	50141A	Armature Assembly (w/ B.E. & F.E. Bearings)	1	-
	50140A	Armature Assembly (w/B.E. & F.E. Bearings)	-	1
3	902654	Bearings B.E.	1	1
4	902550	Bearing F.E.	1	1
5	51839A	Commutator Bracket Assembly (w/Brush BRD Assembly Leads)	1	-
	51837A	Commutator Bracket Assembly (w/Brush BRD Assembly Leads)	-	1
6	50520A	Commutator Bracket	1	1
7	56480A	Strain Relief	1	1
8	962546	Brush Board Screw	2	2
9	50518A	Brush Board Assembly (w/ Springs & Brushes)	1	-
	50519A	Brush Board Assembly (w/Springs & Brushes)	-	1
10	448396	Brush Spring	4	4
11	50516A	Brush Assembly	4	-
	40819A	Brush Assembly	-	4
12	55654A	Lead Assembly	1	-
	55654A	Lead Assembly	-	1
13	55655A	Lead Assembly	1	1
14	59805A	Helical Washer	1	1
15	50515A	Thru Bolt	1	1
16	80501A	Shaft Key	2	2
17	54238A	B.E. Bracket Assembly (Gear Box)	1	1

**Clarke®**  
**Encore S20E 115V**  
**Connection Diagram (00900A-W) 7/02**

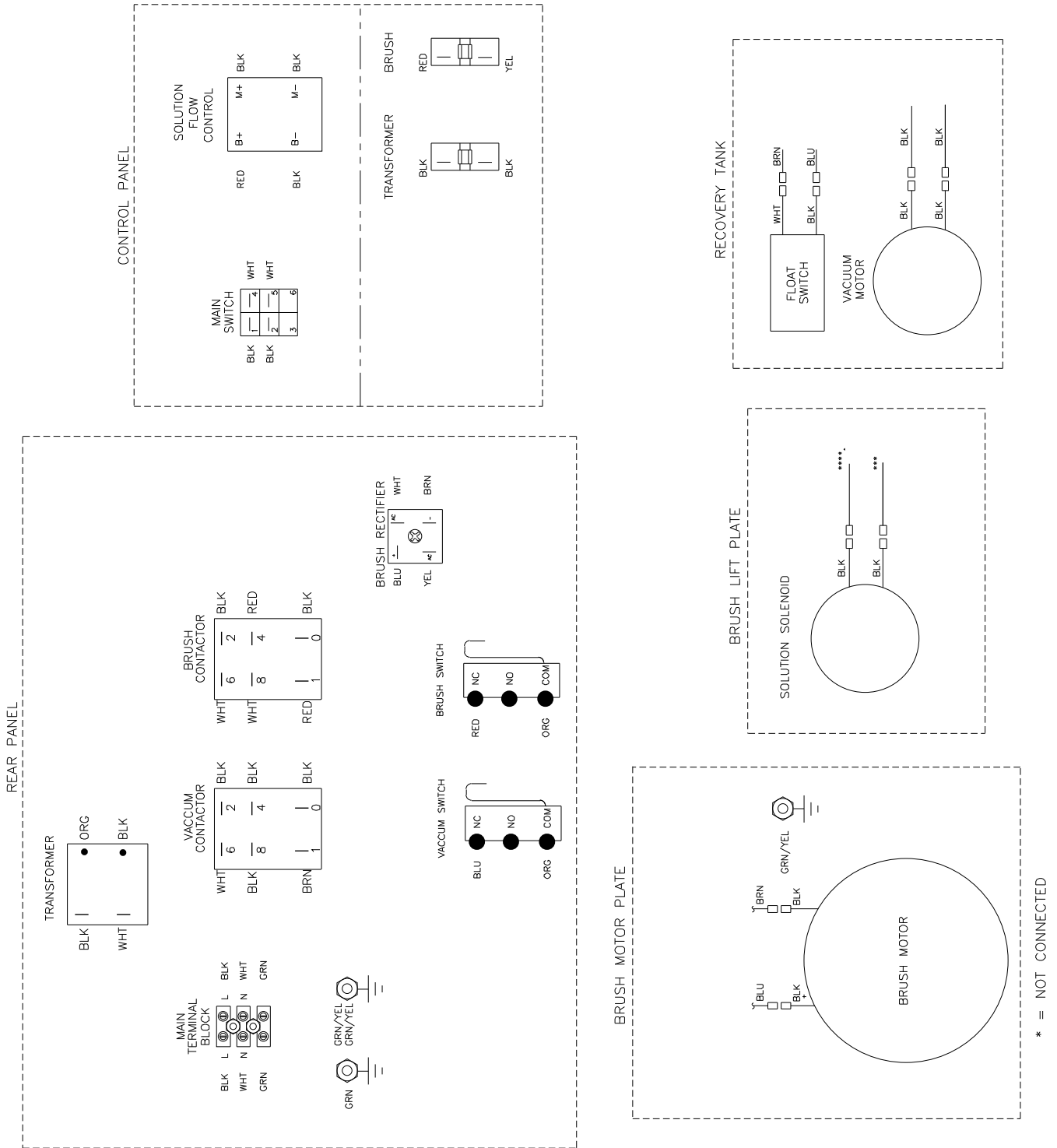

Clarke®  
Encore S20E 115V 7/02

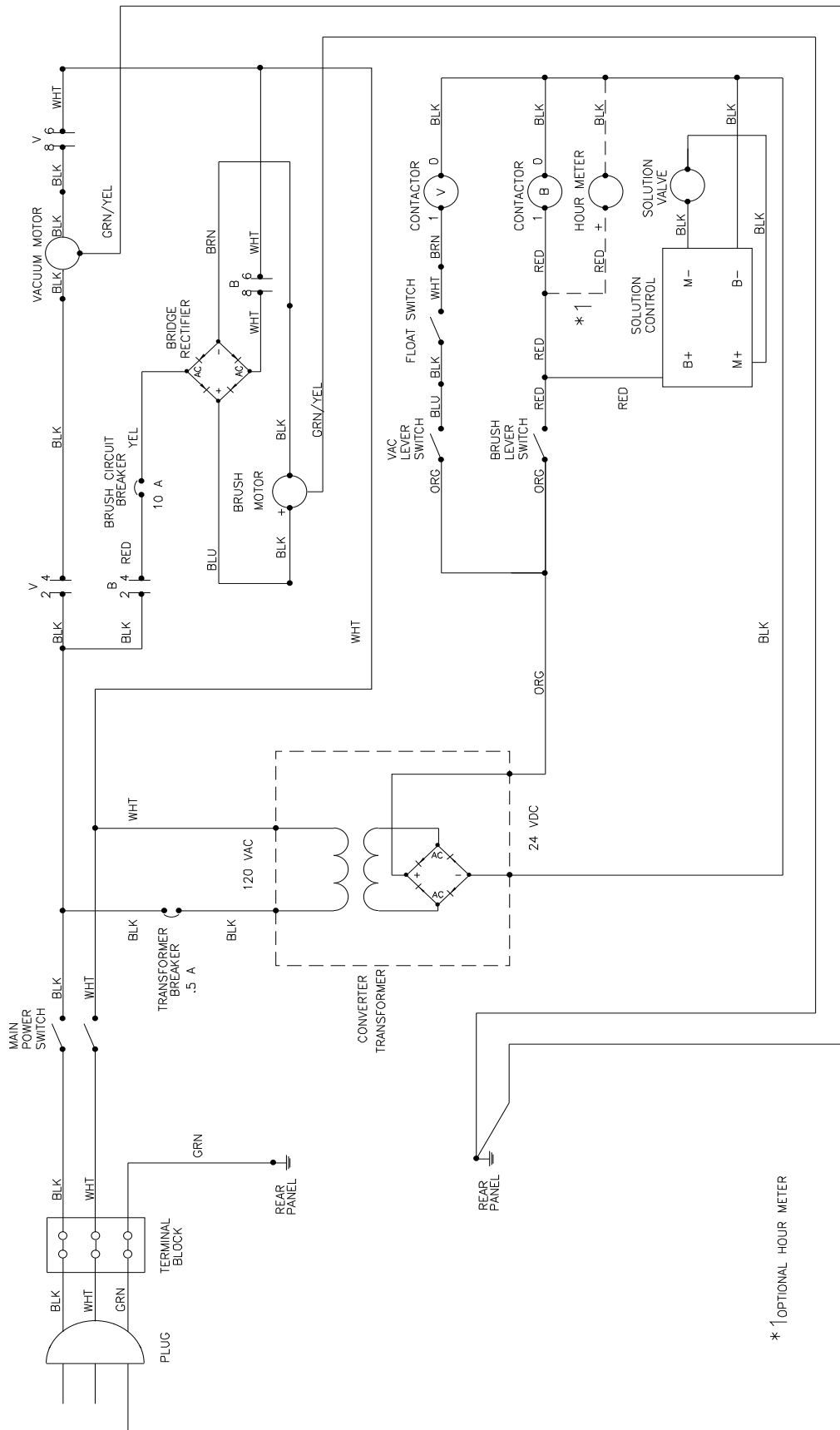

\* 1 OPTIONAL HOUR METER

**Clarke®**  
**Encore S20E 230V**  
**Connection Diagram (00910A - W) 7/02**

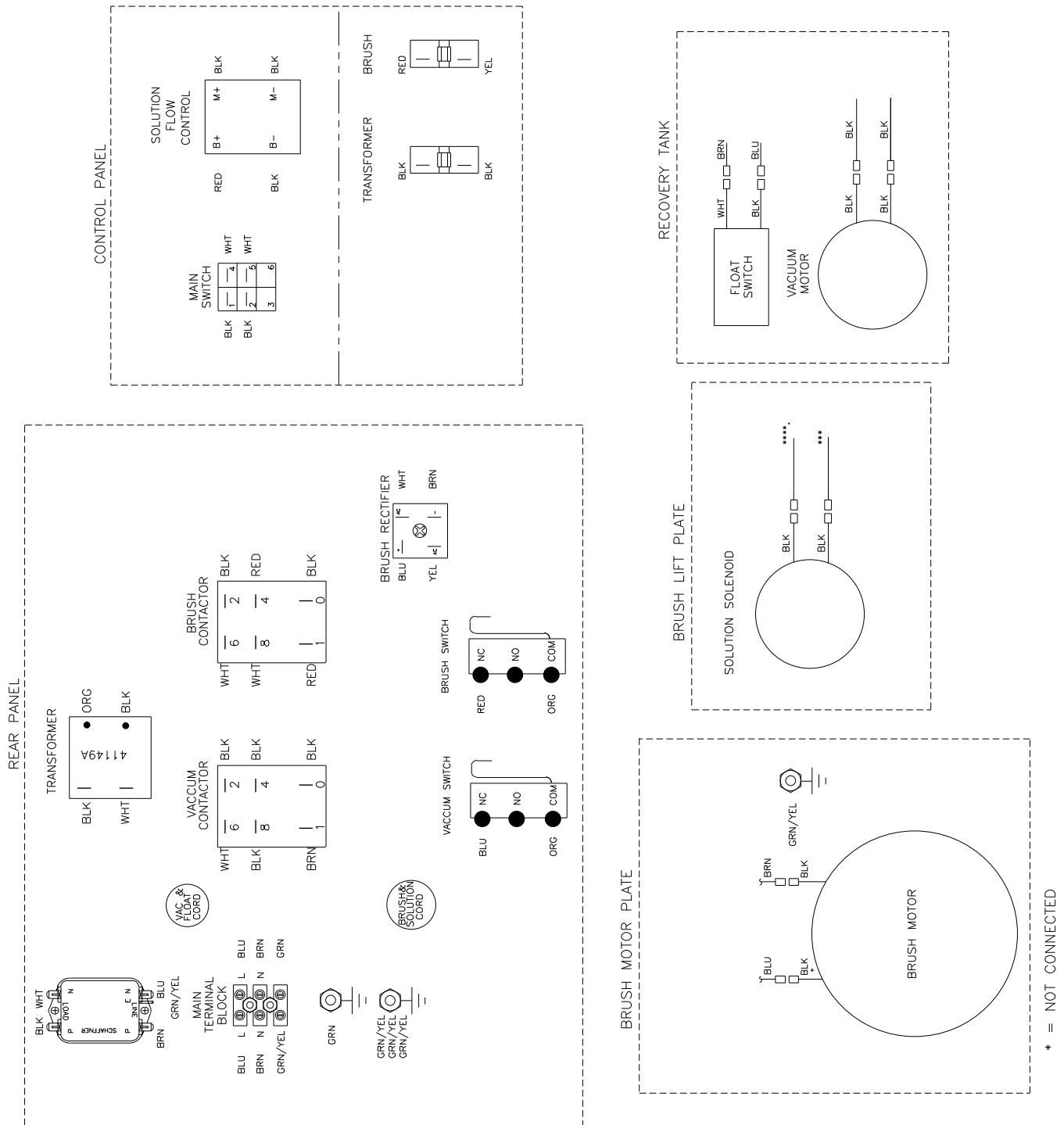





# CLARKE PRODUCT SUPPORT BRANCHES

## U. S. A. Locations

### PRODUCTION FACILITIES

**Clarke®**, Springdale, Arkansas  
2100 Highway 265  
Springdale, Arkansas 72764  
(479) 750-1000  
**Customer Service - 1-800-253-0367**  
**Technical Service - 1-800-356-7274**

**American Lincoln®**, Bowling Green, Ohio 43402  
1100 Haskins Road

### SERVICE FACILITIES

**Clarke®**, Elk Grove, Illinois 60007  
2280 Elmhurst Road  
(847) 956-7900

**Clarke®**, Denver, Colorado 80204  
1955 West 13th Ave.  
(303) 623-4367

**Clarke®**, Houston, Texas 77040  
7215 North Gessner Road  
713-937-7717

### SERVICE AND SALES FACILITY

**American Lincoln® / Clarke**, Madison Heights,  
Michigan 48071-0158  
29815 John R.  
(810) 544-6300

**American Lincoln® / Clarke**, Marietta, Georgia 30066  
1455 Canton Road  
(770) 973-5225

---

**Clarke®**

**Clarke American Sanders**

**A.L. Cook**

**Customer Service Headquarters and Factory**  
2100 Highway 265  
Springdale, Arkansas 72764  
(479) 750-1000

**Technical Service**  
1-800-356-7274

## European Locations

### PRODUCTION FACILITIES

ALTO Danmark A/S, Aalborg  
Blytaekervej 2  
DK-9000 Aalborg  
+45 72 18 21 00

ALTO Danmark A/S, Hadsund  
Industrikvarteret  
DK-9560 Hadsund  
+45 72 18 21 00

### SALES SUBSIDIARIES

ALTO US - Canada, Ontario (Canada)  
4080 B Sladeview Crescent Unit 1  
Mississauga, Ontario L5L 5Y5  
(905) 569 0266

ALTO Overseas Inc., Sydney (Australia)  
1B/8 Resolution Drive  
Caringbah NSW 2229  
+61 2 9524 6122

ALTO Cleaning Systems Asia Pte Ltd., Singapore  
No. 17 Link Road  
Singapore 619034  
+65 268 1006

ALTO Deutschland GmbH, Bellenberg (Germany)  
Guido-Oberdorfer-Straße 2-8  
89287 Bellenberg  
+49 0180 5 37 37 37

ALTO Cleaning Systems (UK) Ltd., Penrith  
Gilwilly Industrial Estate  
Penrith  
Cumbria CA11 9BN  
+44 1768 868 995

ALTO France S.A. Strasbourg  
B.P. 44, 4 Place d'Ostwald  
F-67036 Strasbourg  
Cedex 2  
+33 3 8828 8400

ALTO Nederland B.V.  
Postbus 65  
3370 AB Hardinxveld-Giessendam  
The Netherlands  
+31 184 677 200

ALTO Sverige AB, Molndal (Sweden)  
Aminogatan 18  
Box 4029  
S-431 04 Molndal  
+46 31 706 73 00

ALTO Norge A/S, Oslo (Norway)  
Bjornerudveien 24  
N-1266  
+47 2275 1770

## **Clarke® U.S. WARRANTY**

This Clarke Industrial/Commercial Product is warranted to be free from defects in materials and workmanship under normal use and service for a period of one year from the date of purchase, when operated and maintained in accordance with Clarke's Maintenance and Operations Instructions.

This warranty is extended only to the original purchaser for use of the product. It does not cover normal wear parts such as electrical cable, rubber parts, hoses and motor brushes.

If difficulty develops with the product, you should:

- (a). Contact the nearest authorized Clarke repair location or contact the Clarke Service Operations Department, 2100 Highway 265, Springdale, Arkansas 72764, for the nearest authorized Clarke repair location. Only these locations are authorized to make repairs to the product under this warranty.
- (b). Return the product to the nearest Clarke repair location. Transportation charges to and from the repair location must be prepaid by the purchaser.
- (c). Clarke will repair the product and or replace any defective parts without charge within a reasonable time after receipt of the product.

Clarke's liability under this warranty is limited to repair of the product and/or replacement of parts and is given to purchaser in lieu of all other remedies, including INCIDENTAL AND CONSEQUENTIAL DAMAGES.

THERE ARE NO EXPRESS WARRANTIES OTHER THAN THOSE SPECIFIED HEREIN. THERE ARE NO WARRANTIES WHICH EXTEND BEYOND THE DESCRIPTION OF THE FACE HEREOF. NO WARRANTIES, INCLUDING BUT NOT LIMITED TO WARRANTY OF MECHANICALITY, SHALL BE IMPLIED. A warranty registration card is provided with your Clarke product. Return the card to assist Clarke in providing the performance you expect from your new floor machine.

**Clarke®**, 2100 Highway 265, Springdale, Arkansas 72764.

## **Clarke® POLYDUR TANK EIGHT YEAR U.S. GUARANTEE**

Your new Encore Auto Scrubber has a Polydur Tank. Polydur is a rotationally molded, low-density linear polyethylene that won't crack or dent, and withstands most corrosives and temperature extremes. Clarke backs up your Polydur Tank with its eight year guarantee. If a tank breaks, cracks, or leaks under normal use and service, within eight years of the date of purchase, it will be replaced free.

**Clarke reserves the right to make changes or improvements to its machine without notice.**

**Always use genuine Clarke Parts for repair.**

# **Clarke®**

**2100 Highway 265  
Springdale, Arkansas, 72764**