



ULTRASONIC HUMIDIFIER UHxx



USER, INSTALLATION AND MAINTENANCE GUIDE



Rev 13.03.EN

Table of Contents

1	PACKAGE CONTENT	5
2	SECURITY MEASURES	5
2.1	General Measures.....	5
2.2	Ground Connection.....	5
2.3	Thermo-hygrometric conditions of the installation.....	5
2.4	Power Supply.....	5
2.5	Connection to hydraulic networks	5
2.6	Waste Disposal	6
2.7	Warranty	6
3	MANUFACTURER	6
4	CONFORMITY DECLARATION	7
1	WORKING PRINCIPLE	8
2	CHARACTERISTICS	8
5	INSTALLATION	8
5.1	Components (UH06-OEM)	8
5.2	Hydraulic connections.....	9
5.3	Steam Output	9
5.4	Electrical connections	9
5.5	Connections.....	12
5.6	Control System	12
6	LED INDICATIONS	13
6.1	Normal Operations	13
6.2	Tank Cleaning.....	13

7	ALARM CONDITIONS	13
7.1	Water Failure	14
7.2	Draining System Failure	14
8	TANK DRAINING	14
9	HIGHER CAPACITY MODELS	14
10	SUBMERGED PUMP VERSION	15

Please before using your equipment read this guide carefully, by noting all the precautions and safety instructions reported in it. Keep your equipment in good operative conditions.

Familiarize with the working and security instructions related to the operation of your apparatus before trying to make it function. Keep this guide and any other booklet provided with your apparatus to be able to refer to them later.

1 Package content

Package contains:

- ◇ Ultrasonic Humidifier
- ◇ This User guide
- ◇ A single-phase 220 Vac // 0-14-48 Vac transformer
- ◇ A wall support
- ◇ A feed 220V submerged pump (optional)

2 Security measures

2.1 General Measures

People who are not familiar with this type of equipment or who have not read this manual carefully should not be allowed to use the humidifier

Your humidifier has been designed to be used with AC voltage 230V 50/60Hz. Do not attempt to use the humidifier with a different kind of power supply. Check that the mains voltage corresponds to that of the humidifier.

Your humidifier should always be turned off before any maintenance.

All maintenance and repair work must be performed by the manufacturer, its service agent or qualified service personnel.

Do not cover any opening of the humidifier (Fan) and do not put any object into openings.

2.2 Ground Connection

First operation of any installation is the proper grounding of the equipment, according to the regulations in force in the state and when the equipment is installed.

2.3 Thermo-hygrometric conditions of the installation

Make sure that the environmental conditions of the place where the humidifier is installed are compatible with the requirements of the product as specified in this manual. Each product Elsteam cannot be installed exposed to the weather or freezing temperatures, unless different terms are explicitly expressed in related document.

2.4 Power Supply

The equipment must be connected to the main power supply strictly following the regulations and specifications recorded on the identification label of the equipment.

In particular, it is mandatory that the power lines have the correct section and equipped with power isolator in accordance with safety rules.

2.5 Connection to hydraulic networks

Elsteam equipment may need to be connected to the water mains. In this case it is necessary to strictly comply with the regulations and make sure that any breakage or leakage of water resulting from the installation or from the unit itself cannot cause harm to the environment or to third

parties. Do not install the appliance on walkways or on dangerous objects or susceptible to damage and always provide proper drainage systems able to evacuate any water leakage. In case you have to install the equipment in these areas, please contact the vendor for the related protection tank.

2.6 Waste Disposal



Directive 2002/96/EC of the European Parliament and the relevant national rules impose an obligation not to dispose of WEEE as unsorted municipal civil, but to set up a special collection for obsolete parts of the humidifier.

It is still given the option to the buyer to return the humidifier into disuse at Elsteam Ltd. in case of purchase of an equivalent humidifier. Elsteam will dispose of them in their own or through its agents.

The disposal of electrical or electronic components in an abusive manner and not in accordance with applicable regulations is forbidden by the law. In the event of illegal disposal of electrical and electronic waste, the penalties are specified by local waste disposal legislation.

2.7 Warranty

Elsteam S.r.l. acknowledges to its products guarantees of law applicable at the time of sale of the product, and in any case guarantees at all times, even ten years after the sale, the free replacement of components which considers the apparent problem of construction. Misuse and lack of maintenance will be automatic forfeiture of any form of guarantee.

3 Manufacturer

Manufacturer

Elsteam S.r.l.

Sede legale - amministrativa

Via ENRICO FERMI 496, 21042 CARONNO PERTUSELLA (VA) - ITALY

Contatti

Tel.: (0039) 029659890

Fax: (0039) 0296457007

Email: infocomm@elsteam.com

Web: www.elsteam.com

4 Conformity Declaration

IL COSTRUTTORE

ELSTEAM S.r.l.*Azienda***Via Enrico Fermi, 496***Indirizzo**Provincia***21042***Cap***VA****Caronno Pertusella***Città***Italy***Stato*

DICHIARA CHE LA MACCHINA

Umidificatore ad ultrasuoni*Descrizione***UH***Modello***UH***Serie/Matricola***2008***Anno costr.***Umidificatore ad Ultrasuoni***Denominazione commerciale***Umidificazione di ambienti***Uso previsto***E' conforme alle direttive comunitarie**

- 2006/95/CEE "Direttiva Bassa Tensione" del Consiglio 27 Dicembre 2006
- 89/336/CEE "Compatibilità Elettromagnetica EMC" modificata da:
 - Direttiva 91/263/CEE del Consiglio del 29 aprile 1991
 - Direttiva 92/31/CEE del Consiglio del 28 aprile 1992
 - Direttiva 93/68/CEE del Consiglio del 22 luglio 1993
 - Direttiva 04/108/CEE del Consiglio del 15 dicembre 2004

Claudio Cattaneo*Responsabile***Dirigente***Funzione*

ELSTEAM S.r.l.- Via E. Fermi 496 - 21042 - Caronno Pertusella (VA) - ITALY*Società***2012***Anno*

1 Working principle

The ultrasonic humidifier is an adiabatic humidifier based on the water atomization generated with the vibration of a piezoelectric membrane.

The ultrasonic humidifier causes the evaporation of water by generating microscopic water drops negatively ionized. Thanks to the negative ions, the air is purified by precipitation of the pollutants in suspension. These humidifiers are particularly quiet.

The humidifier consists of a case, an electronic control board, a draining system, a tank, a fan with speed control and a level detector.

The microcontroller based control system performs a cleaning of the water tank at the switch ON and every 4 operating hours.

2 Characteristics

Technical Data				
	UH06-OEM	UH12-206	UH18-306	UH24-406
Capacity	0,6 l/h	1,2 l/h	1,8 l/h	2,4 l/h
Output (diameter)	40 mm	2 x 40mm	3 x 40mm	4 x 40mm
Frequency	1.68 MHz nominal			
Electrical Data				
Tension	220 Vac, 50-60Hz single phase			
Power	40VA	80 VA	120 VA	160 VA
Hydraulic Data				
Water pressure	0,5 - 6 bar			
Inlet Connection	3/4"			
Out Connection	1/4"			
Mechanical Data				
Dimensions [mm] LxWxH	85x126x240	170x126x240	255x126x240	340x126x240
Weigth [kg] with AC Supply	1,7	2,2	2,7	3,2

5 Installation

The humidifier must be installed in a room ventilated and protected, on a vertical surface, plane and rigid. Use the two eyelets of the case and check that the tank is in horizontal position. For multiples units (UH206...UH406) please use at least one eyelet for each unit, to fix humidifier, to prevent lateral forces that may cause breakage of the tank.

The mains transformer can be installed remotely.

5.1 Components (UH06-OEM)

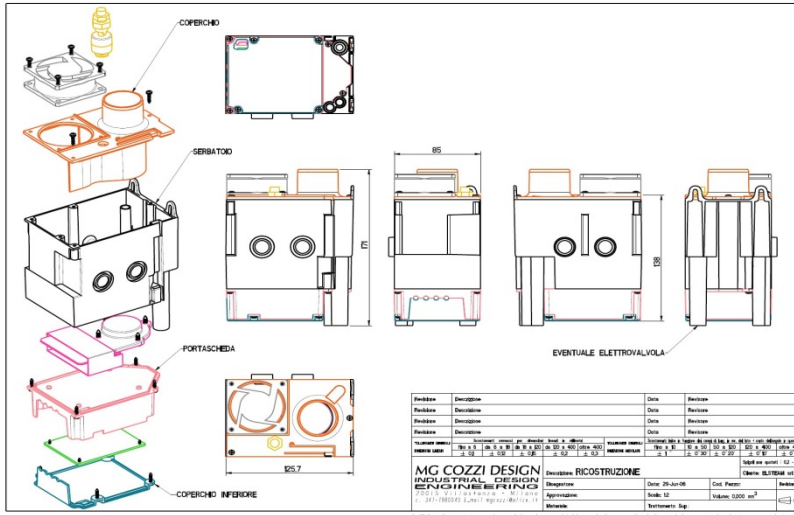

5.2 Hydraulic connections

Hydraulic connection to the units must be realized with flexible pipes which do not cause an action on the tank to avoid damaging the unit.

The hydraulic connections are positioned on the bottom side of the humidifier. Input connection is 3/4" and output is 1/4".

The minimal pressure at the entry of the pump should not be lower than 0.5 at maximum flow.

5.3 Steam Output

The steam output is positioned in the upper part of the humidifier (top cover). The outlet has a diameter of 40mm. To avoid the release of micro-droplets of water by the output should be installed a distribution ramp of 40 cm minimum. The ramp can be made of PVC or other material (as required by the application). In case you cannot install a ramp of 40 cm at the exit you can install a double stitched at 90° to create a trap for micro-drops.

When you use the humidifier in fan-coil applications or insert the exit ramp in a duct must pay attention to the existing backpressure. In the case of fan-coil is mandatory to realize a ramp of diffusion with equidistant holes, to be installed in the direction of the air flow so that the venturi effect favours the mixing of the steam.

In the case of entry into the duct, it is recommended to use the special cover with the possibility of drawing air from the duct itself.

5.4 Electrical connections



All work concerning electrical installations WILL HAVE to be carried out exclusively by qualified personnel (ex electricians or technicians laying out from a suitable formation). The customer IS responsible for the adequacy of the personnel used.



Please check that power supply is disconnected before any maintenance and installation operation.

The person in charge of installation will have to ensure the following points:

- ◇ Size of electrical cables must be appropriate for the maximum current being provided.
- ◇ The power supply cable will have to be protected using an appropriate cable gland.
- ◇ Each connection of terminal will have to be firmly protected by a fixing of cable.



Before the beginning of installation (and all operations of maintenance and maintenance without panel) the power supply must be disconnected on all the lines and insured against an involuntary connection! Before making electric connections check that the tension corresponds to those of the humidifier!

The electric terminals are positioned inside the apparatus (remove the screws which block the lower panel of the case to reach them).

In case the mains transformer is not delivered already connected to the humidifier, please use table below to connect.

Mains transformer Connections			
0V			220
0V		14	48V
0V	BLUE cable	Electronic Board	
14V	RED cable	Electronic Board	
48V	VIOLET cable	Electronic Board	
0V	BLUE cable	Circuit breaker	
220V	BLUE cable	Circuit breaker	

Below picture shows positioning of electrical terminals on the electronic board.

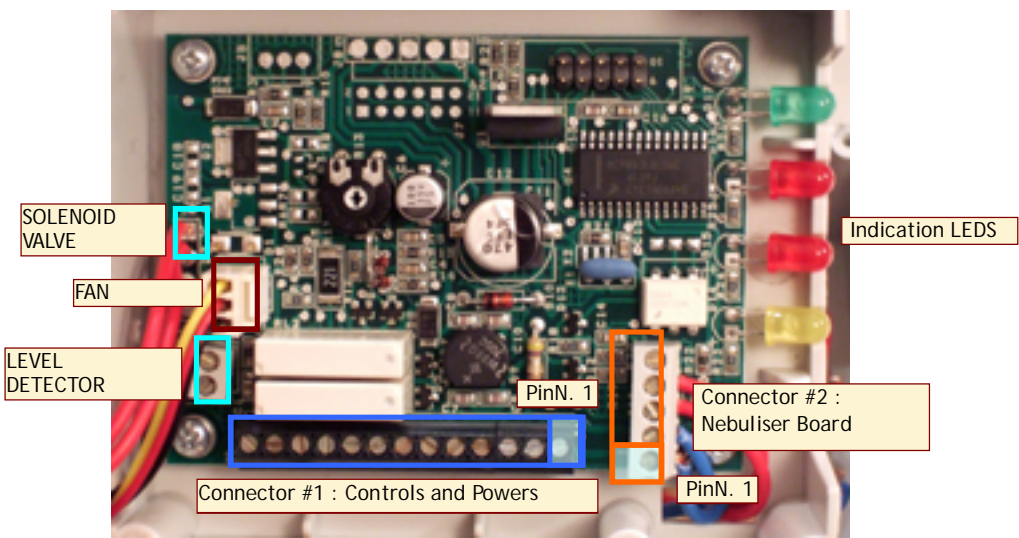

Figure 1 - Electronic Board

N°	Name	Description
1,2	48Vac	AC Input 48Vac Connect cables from mains transformer (4terminals 0 and 8Vac)
3	T	GND
4,5	14Vac	AC Input 14Vac Connect cables from mains transformer (terminals 0 and 14Vac)
6	0 V	External Regulator Reference Voltage
7	REG	External Regulator Input Voltage (type 0 ... 10v) or enable signal
8	V+	External Regulator Power Supply (type 4 ... 20mA)
9	RTH	External Regulator Input Signal(type 4...20mA)
10,11	ALRM	Alarm Output Normally opened. Closed during alarm conditions (Max. 2 A, 48 V).
12,13	REQ/ ALIM. PUMP	Production Output. These contacts are opened when the production is stopped. They close when productions is required (Max. 2 A, 48 V). If the submerged pump is used these contacts can be used to switch On/Off the pump (Requires a different firmware)

Table 1: Electrical and Control Connections (connector#1 in Fig.1)

N°	Name	Description
1	Vac	48 Vac power supply for nebulizer board
2		
3	In	Control signal for nebulizer board
4		

Table 2 : Nebulizer Board Connections (connector#2 in Fig.1)

5.5 Connections

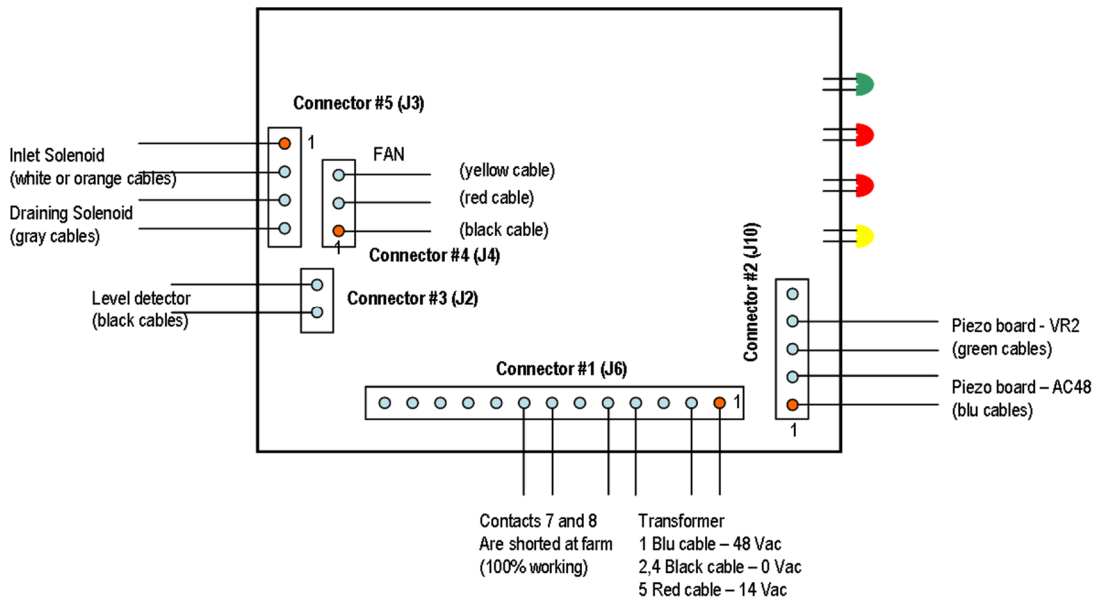

5.6 Control System

The terminals of control and alarm signals are located on the electronic control board (connector 1 - see Figure 1 - Electronic Board) (remove the lower panel of the case to reach them). The openings for the cables are located on the lower side of the case. Use cables with a section of max. 1sqmm.

The electronic controller embedded can use an external signal (from an external controller) or internal proportional controller.

According to the operating process chosen, select suitable connection in the list.

Continuous Working

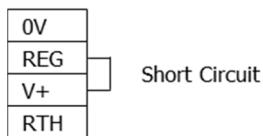

Connect **V+** et **REG**

Use R13 potentiometer on the control board to regulate the request of humidity (0% clockwise and 100% counter-clockwise)

External ON/OFF controller or Humidistat

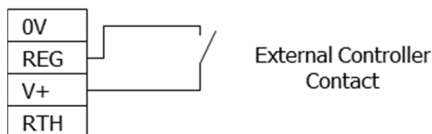

Connect the external Controller to the terminals **REG** and **V+** as in the schematic

External PROPORTIONAL controller (0..10V)

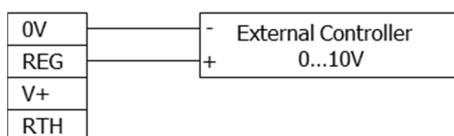

Connect the external Controller to the terminals **REG** and **0V** as in the schematic

6 Led Indications

The working operation and status of the humidifier is indicated using 4 LEDs on the front panel.

Pos	Colours	Description
1	GREEN	IN OPERATION If fixed or blinking indicates that the humidifier is working.
2	RED	TANK CLEANING If ON indicates the cleaning phase
3	RED	FAN FAILURE. If ON indicates a failure on the FAN
4	YELLOW	LOW WATER LEVEL If ON indicates low water level in the tank



Front Panel LED

6.1 Normal Operations

In the case of normal operation the green led (1) is lit with intensity proportional to the mist production. If the external or internal controller does not require mist production, the green led (1) blinks.

In the case of absence of water (insufficient pressure or solenoid input valve failure) the yellow (4) led light to indicate that there is no mist production.

Red led (2) and (3) must be OFF.

6.2 Tank Cleaning

The microprocessor based control system, performs automatic tank cleaning at start-up and every 6 hours of operation. This cleaning phase allows limestone deposit to be eliminated from the tank.

During this cleaning phase green led (1) blinks to indicate that the humidifier is working, but not producing mist.

Tank cleaning is performed in two phases signalled by a different state of red led (2):

- ◇ Water input in the tank and starting of the siphon system (red led (2) is ON)
- ◇ Cleaning and draining of the tank (red led (2) is blinking)

The yellow led (4) indicates the level of water in the tank.

7 Alarm Conditions

In case of failure the micro-controller based board stops mist production and water input.

After a wait period of 5 minutes the humidifier automatically starts with tank cleaning phase.

During the stop phase green led (1) is OFF, red led (3) could signal FAN failure; red led (2) and yellow led (4) identify the failure.

7.1 Water Failure

This failure is signalled with yellow led (2) blinking and green led (1) OFF.

7.2 Draining System Failure

Draining system failure during tank cleaning phase. The causes of this failure can be a problem with draining solenoid valve or an obstruction in the draining system (pipes).

This failure is signalled with red led (2) blinking and green led (1) OFF.

8 Tank draining

When the humidifier is not used is mandatory to execute a manual draining. To complete this operation executes following steps:

1. Close input valve
2. Switch OFF the unit
3. Switch ON the unit
4. Wait until tank is empty
 1. Green LED blink
 2. Yellow LED is ON
5. Switch OFF the unit

9 Higher Capacity Models

The UH06 humidifier can be assembled to form units with higher capacity. If more units are assembled there is a single control board and several nebuliser units as there are units assembled. The figure below depicts the version UH24-406, with a capacity of 2.4 l / h.

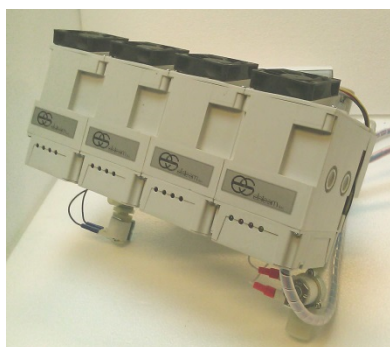

10 Submerged Pump Version

The unit can operate with a pump feeding the humidifier. In the case of use of a submerged 220Vac pump, power supply of the pump must be carried out according to the following schematic.

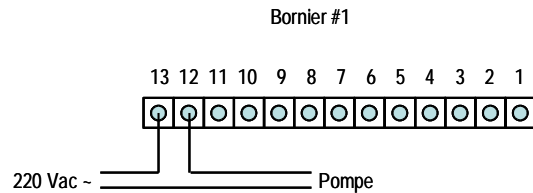

The installation of the pump with the tank must respect the outline of below figure. The tank can be installed in a position higher than the humidifier. If the tank is installed in a position lower than the humidifier the difference between solenoid valve and the bottom of the tank should not exceed 60cm with the standard pump provided by Elsteam.

