

COLORdash™ Batten

Snapshot

OK on Dimmer	⊘
Outdoor OK	⊘
Sound Activated	⊘
DMX512	✓
Master/Slave	✓
Autoswitching Transformer	✓
Replaceable Fuse	✓
User Serviceable	⊘
Duty Cycle	⊘

USER MANUAL

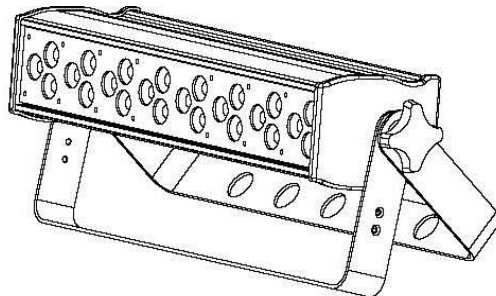

Chauvet, 3000 N 29th Ct, Hollywood, FL 33020 U.S.A.
(800) 762-1084 – (954) 929-1115
FAX (954) 929-5560
www.chauvetlighting.com

TABLE OF CONTENTS

1. Before You Begin	3
What is included.....	3
Unpacking Instructions	3
Safety Instructions	4
LED Expected Lifespan	4
2. Introduction	5
Features	5
DMX Channel Summary	6
Product Overview.....	7
3. SETUP	8
AC Power	8
Mounting.....	9
Orientation.....	9
Rigging	9
Fixture Connection.....	10
Lens Assembly Installation/Replacement	10
Fixture Linking.....	12
Data Cabling	12
DMX Data Cable	12
Cable Connectors	12
3-Pin to 5-Pin Conversion Chart.....	13
Setting up a DMX Serial Data Link.....	13
Master/Slave Fixture Linking	13
4. Operating Instructions	14
Control Options	14
DMX-512 control without "ID" address.....	14
DMX-512 addressing with ID address.....	14
COLORcon™ Setup	15
Setting the DMX address.....	16
Control Panel Functions	16
Password Menu Lockout	16
Upload Customs.....	17
Menu Map	18
DMX512 Channel Values	20
Important Notes about STAGE 1 DMX Operation	23
5. COLORado™ Controller	24
Overview	24
Setup	24
Menu Map	25
Wash Program	25
Effect Program	25
Custom Program	26
Play Schedule	26
Clock.....	26
Schedule	26
Settings.....	26
Activating password mode.....	27
Control via external DMX.....	27
Technical Support	28
Contact Us.....	28
6. Appendix	29
DMX Primer.....	29
General Maintenance	30
Returns Procedure.....	30
Photometrics	31
Mini Par Service Maintenance Guide.....	32
Blow-out Diagram.	33
Technical Specifications	35

1. BEFORE YOU BEGIN

What is included

- 1 x COLORdash™ Batten
- 1 x Power cable with plug
- 1 x 6ft (2m) power linking cable
- 1 x Warranty Card
- 1 x User Manual

Unpacking Instructions

Immediately upon receiving a fixture, carefully unpack the carton, check the contents to ensure that all parts are present, and have been received in good condition. Notify the shipper immediately and retain packing material for inspection if any parts appear damaged from shipping or the carton itself shows signs of mishandling. Save the carton and all packing materials. In the event that a fixture must be returned to the factory, it is important that the fixture be returned in the original factory box and packing.

Safety Instructions



Please read these instructions carefully, which includes important information about the installation, usage and maintenance of this product.

- Please keep this User Guide for future consultation. If you sell the unit to another user, be sure that they also receive this instruction booklet.
- Always make sure that you are connecting to the proper voltage, and that the line voltage you are connecting to is not higher than that stated on the decal or rear panel of the fixture.
- The unit must be installed in a location with adequate ventilation, at least 20in (50cm) from adjacent surfaces. Be sure that no ventilation slots are blocked.
- Always disconnect from power source before servicing or replacing lamp or fuse and be sure to replace with same lamp source.
- Secure fixture to fastening device using a safety chain. Never carry the fixture solely by its head. Use its carrying handles.
- Maximum ambient temperature (Ta) is 104°F (40°C). Do not operate fixture at temperatures higher than this.
- In the event of a serious operating problem, stop using the unit immediately. Never try to repair the unit by yourself. Repairs carried out by unskilled people can lead to damage or malfunction. Please contact the nearest authorized technical assistance center. Always use the same type spare parts.
- Never connect the device to a dimmer pack.
- Make sure the power cord is never crimped or damaged.
- Never disconnect the power cord by pulling or tugging on the cord.
- Avoid direct eye exposure to the light source while it is on.
- Do not daisy chain power to more than 13 units @120volts.

Note! *Power linking may not be available for 230V versions*

Caution! *There are no user serviceable parts inside the unit. Do not open the housing or attempt any repairs yourself. In the unlikely event your unit may require service, please contact CHAUVET at: 954-929-1115.*

Caution! *After prolonged periods of operation, the fixture chassis may reach high temperatures. Use caution when handling this fixture.*

LED Expected Lifespan

LEDs gradually decline in brightness over time. HEAT is the dominant factor that leads to the acceleration of this decline. Packaged in clusters, LEDs exhibit higher operating temperatures than in ideal or singular optimum conditions. For this reason when all color LEDs are used at their fullest intensity, life of the LEDs is significantly reduced. It is estimated that a viable lifespan of 40,000 to 50,000 hours will be achieved under normal operational conditions. If improving on this lifespan expectancy is of a higher priority, place care in providing for lower operational temperatures. This may include climatic-environmental and the reduction of overall projection intensity

2. INTRODUCTION

Features

- 3, 4, 10, or 12-channel DMX-512 LED bank system (with ID addressing)
- Operating modes
 - 3-channel: RGB control
 - 4-channel: RGB, dimmer
 - 10-channel: RGB, ID, dim, macro, strobe, automatic, custom, module select
 - 12-channel: RGB of 4 separate sections
- RGB color mixing with or without DMX controller
- Built-in automated programs via master/slave or DMX
- Program and recall custom programs via master/slave or DMX
- Adjustable fan speeds

ADDITIONAL FEATURES

- High-power, 1W (350mA) LEDs
- 3-pin and 5-pin DMX connections
- Additional (IEC) power output: max 13 units @ 120V (see manual for details)
- Attach multiple units together with the included bracket
- LCD display with password protection
- Transfer custom programs between fixtures
- Double-bracket yoke doubles as floor stand

OPTIONS

- COLORado Controller (COLOR-CON)
- Optical systems: 15° (CL20X15), 30° (installed)

DMX Channel Summary

The COLORdash™ Batten has a total of 4 DMX channel configurations, referred to as “Personalities” in this manual and in the fixture onboard control board. The 4 personalities are [STAGE 1, BLOCK, ARC1, ARC1+D]. Each of the different personalities can be accessed from the control panel. Please see section on “Control Panel Functions” on a description on how to accomplish this.

[STAGE 1]	CHANNEL	DESCRIPTION
	1	Dimmer
	2	Red
	3	Green
	4	Blue
	5	Color Macro
	6	Strobe
	7	Auto & Custom Programs
	8	Auto Speed Adjustment
	9	ID Address Selection
	10	Block Selection

[BLOCK]	CHANNEL	DESCRIPTION
	1	Red 1
	2	Green 1
	3	Blue 1
	4	Red 2
	5	Green 2
	6	Blue 2
	7	Red 3
	8	Green 3
	9	Blue 3
	10	Red 4
	11	Green 4
	12	Blue 4

[ARC 1]	CHANNEL	DESCRIPTION
	1	Red
	2	Green
	3	Blue

[ARC1+D]	CHANNEL	DESCRIPTION
	1	Dimmer
	2	Red
	3	Green
	4	Blue

Product Overview

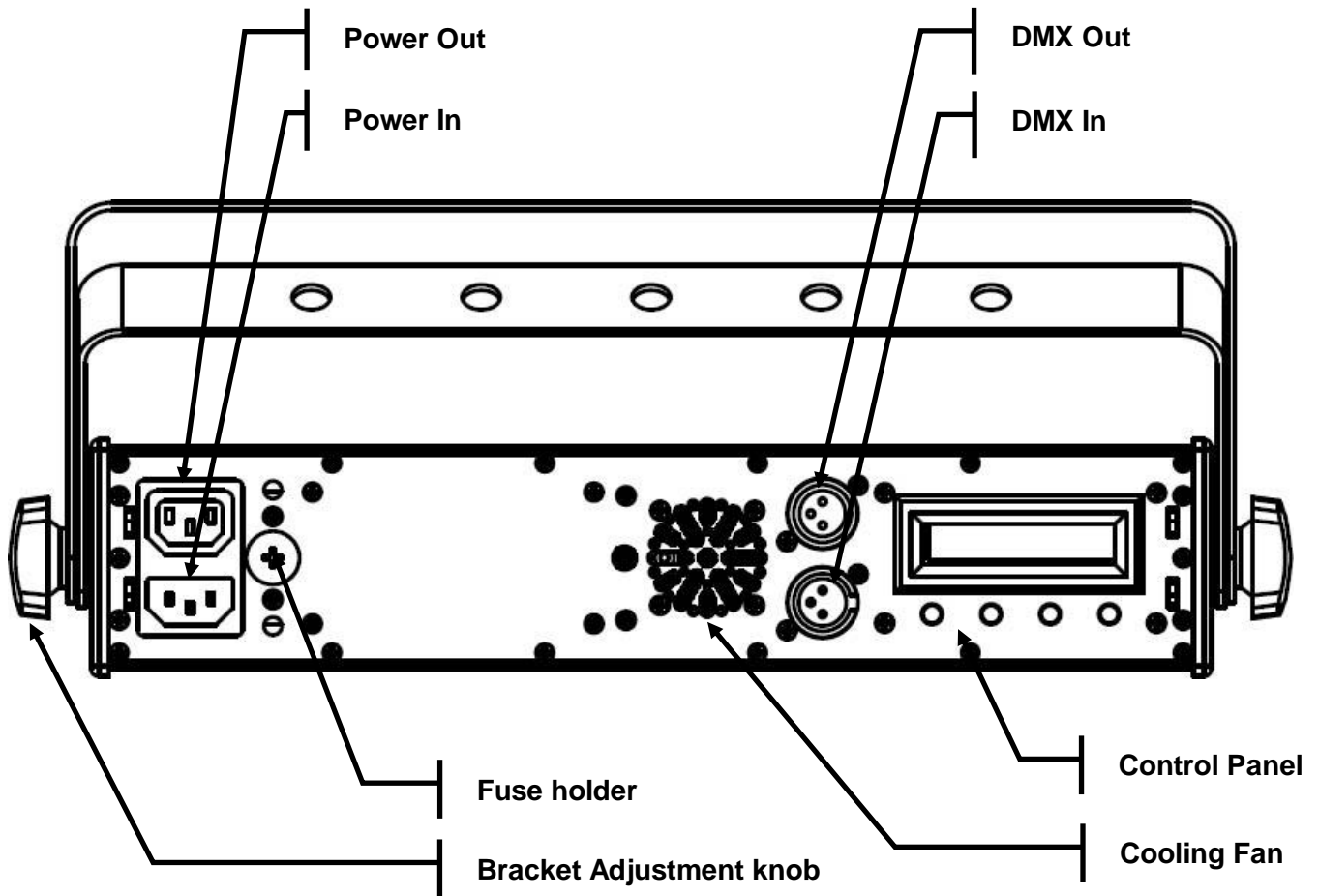
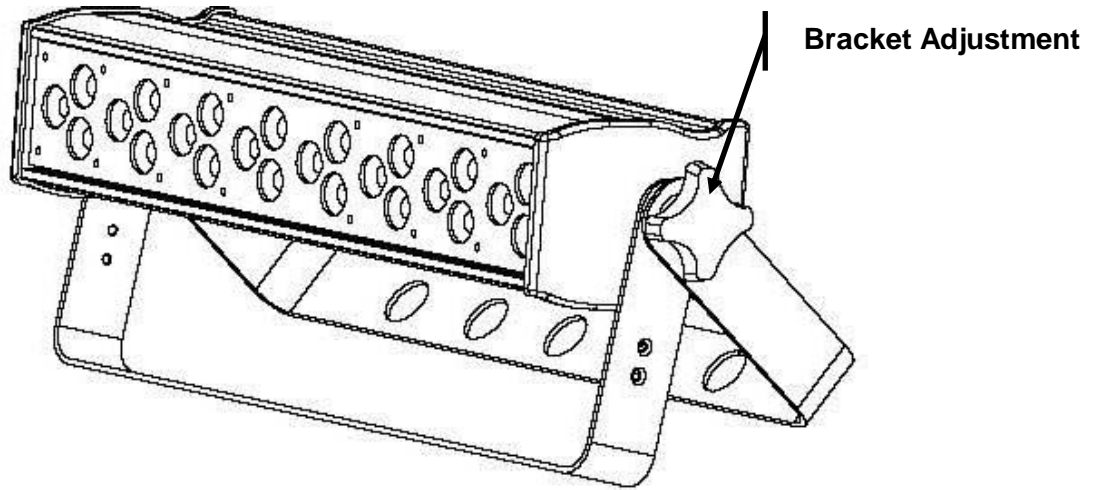

3. SETUP

AC Power

This fixture has an auto-switching power supply that can accommodate a wide range of input voltages. The only thing necessary to do before powering on the unit is to make sure the line voltage you are applying is within the range of accepted voltages. This fixture will accommodate between 100V and 240V AC 50-60 Hz. All fixtures must be powered directly off a switched circuit and cannot be run off a rheostat (variable resistor) or dimmer circuit, even if the rheostat or dimmer channel is used solely for a 0% to 100% switch.

Warning! *All fixtures must be connected to circuits with a suitable Earth Ground.*

Depending on the application, the lighting fixture may require a different connector. Please refer to the below wire color code if installing a new connector.

Wire	Connection
Brown	AC Live
Blue	AC Neutral
Green/Yellow	AC Ground

Connection	Pin
AC Live	1
AC Neutral	2
Ground(Earth)	3

Mounting

Orientation

This fixture may be mounted in any safe position.

Rigging

The fixture includes a mounting yoke to which a rigging clamp can be attached. You must supply your own clamp and make sure the clamp is capable of supporting the weight of this fixture. You can order "C" and "O"-clamps from any CHAUVET dealer or distributor (CLP-15, CLP-06 recommended).

Note: There are 2 types of applications for this fixture: floor stand for up lighting, and overhead use for down lighting. If you are using this fixture in a hanging/mounted application, then you must use at least 1 safety cable/chain for each fixture in addition to the mounting brackets.

If hanging the fixture for over head use, then please follow the below steps.

1. Block access below the work area and use suitable and stable platform when installing or servicing fixture.
2. Safety cables must always be used, secured through the heat sink ventilation passageway. The safety cable must be capable of holding 10 times the weight of the fixture.
3. Verify the structure can hold 10 times the weight of all to-be installed fixtures.

Caution!

After prolonged periods of operation, the fixture chassis may reach high temperatures. This fixture must be mounted in a ventilated location, as it uses forced convection cooled.

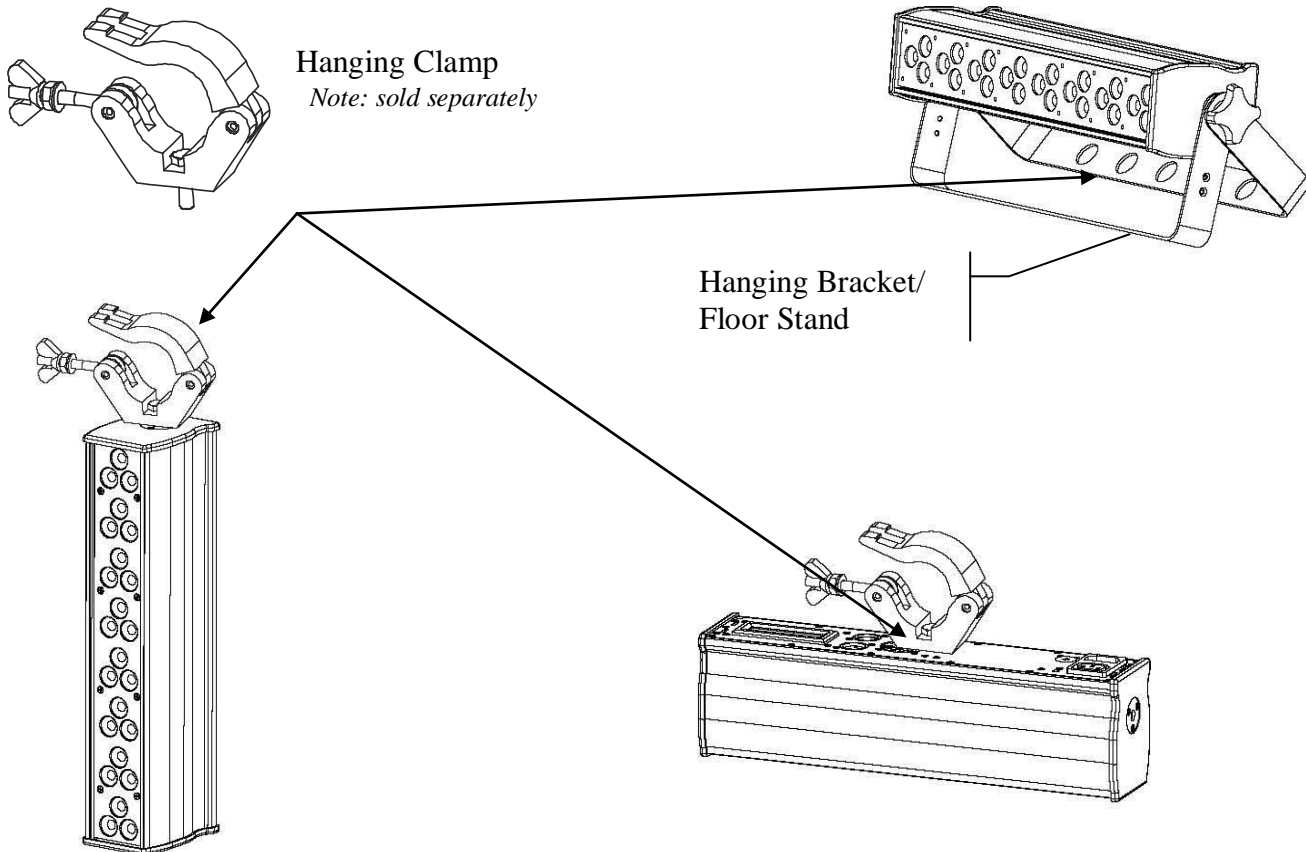

Fixture Connection

The fixture may be stacked together horizontally to create a strip light or vertically for a blinder effect. This can be used for runway lighting or cycloramas. With the different methods of bracket mounting, this turns this fixture into a very versatile lighting tool.

Note: In this configuration, it is only recommended that a maximum of 3 fixtures be stacked together at a time.

Note: You will still need to connect and configure each fixture separately. For the power, you may use the linking cables provided with the fixture.

Please follow the below instructions for stacking the fixtures horizontally.

1. Remove the brackets that come with the fixtures, in order to make room for the attachment screws.
2. In the same location where the bracket attaches, you may install the linking screws. This will attach the fixtures close together.
3. You may use the brackets for this configuration, or simply install the clamp directly to the fixture as showed on the previous page.

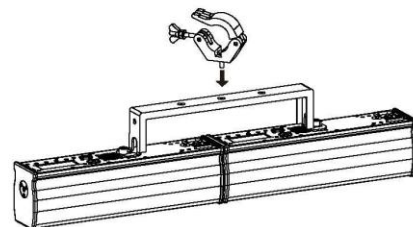
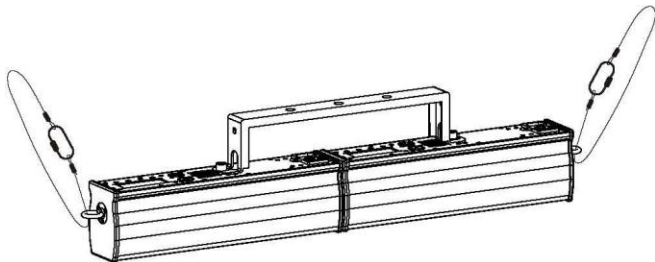
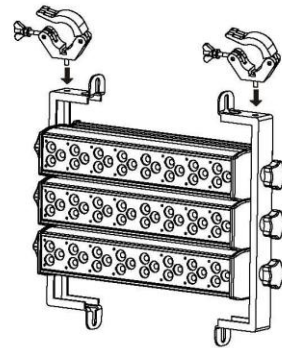
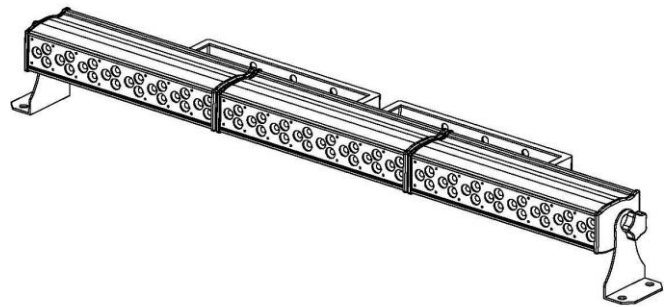
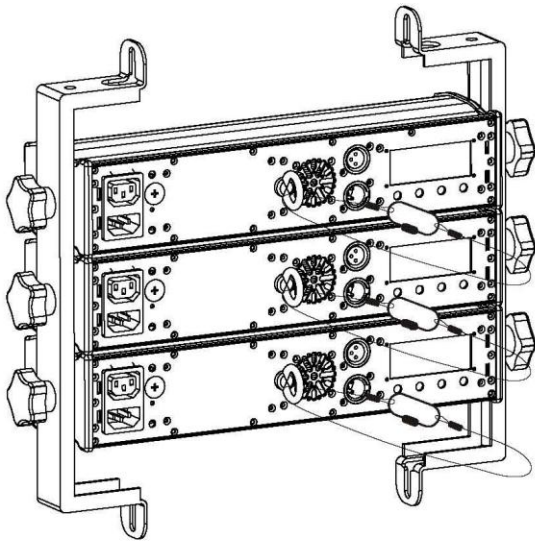

Lens Assembly Installation/Replacement

The COLORdash™ Batten comes with 15° lens assembly pre-installed from the factory. However, there is 1 other optional lens kit (**CL20X30**) available as accessories, which will alter the beam angle. These each come in packages of 20pcs each. Therefore, if you have a fixture that has more than 20 LEDs (such as the COLORdash™ Batten), then be sure to take this into account. Please follow the below instructions for proper

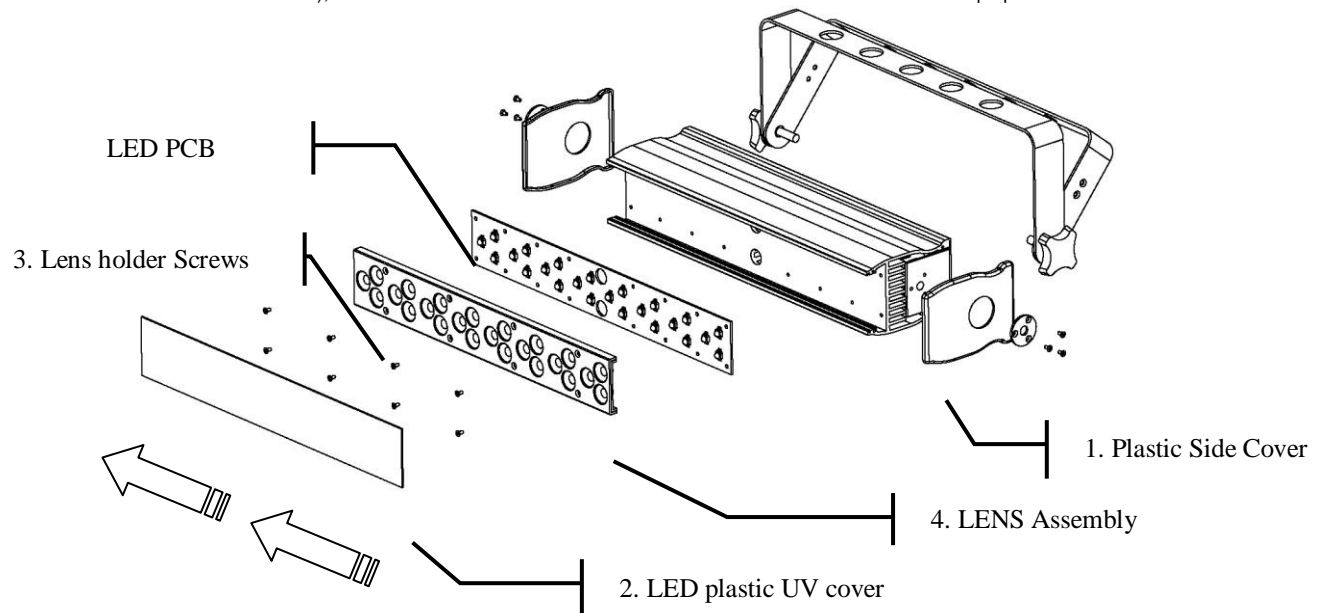

1. Remove the side, plastic UV cover (black) by removing the screws that hold it in place. There are 4 screws to remove for this step.
2. Slide the LED plastic cover out through the side of the plastic black cover that was removed.
3. After removing the side cover, remove the screws that hold the lens assembly in place. There are 8 screws for this step.

Note: use care when performing this procedure, as this gives you direct access to the LEDs, which are very fragile.

4. You now should have full access to the lens assembly. This must be removed and the old lenses must be replaced with the new lenses. The same assembly is to be reinstalled with the new lenses in place and the process is complete.

Warning!

When replacing the lens assembly, please make sure that the power is disconnected from the fixture beforehand.

Fixture Linking

You will need a serial data link to run light shows of one or more fixtures using a DMX-512 controller or to run synchronized shows on two or more fixtures set to a master/slave operating mode. The combined number of channels required by all the fixtures on a serial data link determines the number of fixtures the data link can support.

Important: Fixtures on a serial data link must be daisy chained in one single line. To comply with the EIA-485 standard no more than 32 devices should be connected on one data link. Connecting more than 32 fixtures on one serial data link without the use of a DMX optically-isolated splitter may result in deterioration of the digital DMX signal.

Maximum recommended serial data link distance: 500 meters (1640 ft.)

Maximum recommended number of fixtures on a serial data link: 32 fixtures

Data Cabling

To link fixtures together you must obtain data cables. You can purchase CHAUVET-certified DMX cables directly from a dealer/distributor or construct your own cable. If you choose to create your own cable please use data-grade cables that can carry a high quality signal and are less prone to electromagnetic interference.

DMX DATA CABLE

Use a Belden® 9841 or equivalent cable which meets the specifications for EIA RS-485 applications. Standard microphone cables cannot transmit DMX data reliably over long distances. The cable will have the following characteristics:

*2-conductor twisted pair plus a shield
Maximum capacitance between conductors – 30 pF/ft.
Maximum capacitance between conductor and shield – 55 pF/ft.
Maximum resistance of 20 ohms / 1000 ft.
Nominal impedance 100 – 140 ohms*

CABLE CONNECTORS

Cabling must have a male XLR connector on one end and a female XLR connector on the other end.

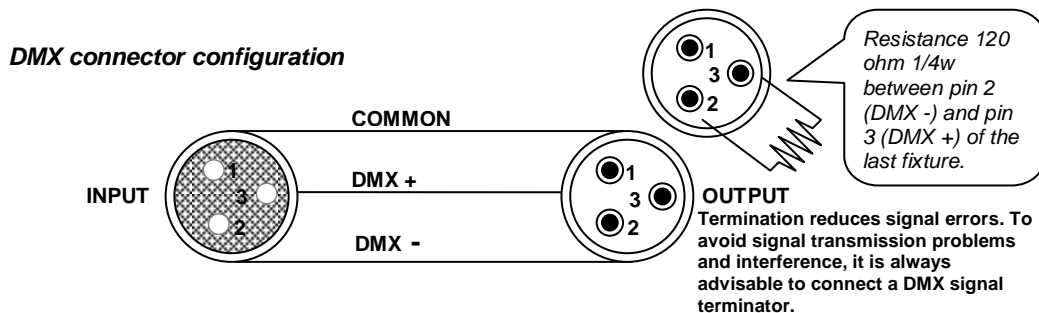

CAUTION Do not allow contact between the common and the fixture's chassis ground. Grounding the common can cause a ground loop, and your fixture may perform erratically. Test cables with an ohm meter to verify correct polarity and to make sure the pins are not grounded or shorted to the shield or each other.

3-PIN TO 5-PIN CONVERSION CHART

Note! If you use a controller with a 5 pin DMX output connector, you will need to use a 5 pin to 3 pin adapter. CHAUVET Model No: DMX5M, or DMX5F. The chart below details a proper cable conversion:

3 PIN TO 5 PIN CONVERSION CHART		
Conductor	3 Pin Female (output)	5 Pin Male (Input)
Ground/Shield	Pin 1	Pin 1
Data (-) signal	Pin 2	Pin 2
Data (+) signal	Pin 3	Pin 3
Do not use		Do not use
Do not use		Do not use

Setting up a DMX Serial Data Link

1. Connect the (male) 3 pin connector side of the DMX cable to the output (female) 3 pin connector of the controller.
2. Connect the end of the cable coming from the controller which will have a (female) 3 pin connector to the input connector of the next fixture consisting of a (male) 3 pin connector.
3. Then, proceed to connect from the output as stated above to the input of the following fixture and so on.

CHAUVET Certified DMX Data Cables

Order Code	Description
DMX1.5	DMX Cable 1.5m/4.9ft
DMX4.5	DMX Cable 4.5m/14.8ft
DMX10	DMX Cable 10m/32.8ft

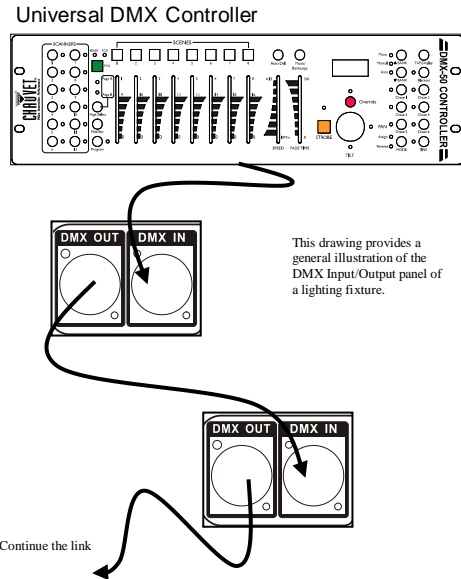

Master/Slave Fixture Linking

1. Connect the (male) 3 pin connector side of the DMX cable to the output (female) 3 pin connector of the first fixture.
2. Connect the end of the cable coming from the first fixture which will have a (female) 3 pin connector to the input connector of the next fixture consisting of a (male) 3 pin connector. Then, proceed to connect from the output as stated above to the input of the following fixture and so on.

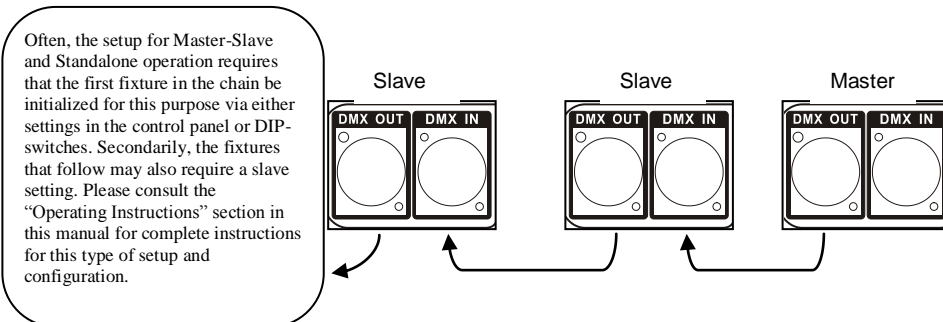

4. OPERATING INSTRUCTIONS

Control Options

The COLORdash™ Batten is addressable in the DMX range of 001 to 512. In its simplest control form, this allows for the control of up to 56 fixtures in the 10-channel Stage1 personality; however, a secondary “ID” address system exists for use in a limited DMX universe and architectural environments. The “ID” address system allows the user to assign up to 66 fixtures within the same DMX address; in effect, multiplying the control of the COLORdash™ Batten within a single universe to 3,696 fixtures. The “ID” address system is accessed using DMX channel 9 [Stage 1]. Consideration must be placed when programming live performances or cues that need to trigger on demand or on a time line. So, to remain within one second execution time, program no greater than 10 fixtures on ID addressing per DMX channel.

DMX-512 control without “ID” address

The COLORdash™ Batten operates on 10 channels of DMX (“STAGE1” personality). Address each fixture in increments of 10 channels. (I.e. 1,10,19,28, etc...) To save time you can use the same DMX address for each fixture. All fixtures will then respond simultaneously to control. You may also group your fixtures and address those groups alike for faster programming and control.

1. Access the control panel function by pressing the **(MENU)** button until the **{RUN MODE}** is displayed.
2. Press **(SET)** and use the **(UP/DOWN)** buttons to select **{DMX}** function.
3. Then, Press **(MENU)** button until **{DMX512 ADDRESS}** is displayed.
4. Press the **(SET)** button.
6. Use the **(UP/DOWN)** buttons to increase or decrease channels between 001 and 512.
7. Press the **(SET)** button to confirm action. Then press **(MENU)** to exit.

Deactivate ID addressing in each fixture by setting panel function **{ID ON/OFF}** to OFF.
{MENU} ⇨ {SETTINGS} ⇨ {ID ON/OFF} ⇨ [OFF]

Notes: If ID addressing is not deactivated in the fixture’s control panel function, unintended results may occur if values are present in channel 9. Make sure values on channel 9 are set to “0”.

DMX-512 addressing with ID address

1. Follow instructions 1 ~ 4 for DMX512 addressing.
2. Activate ID addressing in each fixture by setting panel function **{ID ON/OFF}** to ON.
{MENU} ⇨ {Settings} ⇨ {ID ON/OFF} ⇨ [ON]
3. For every DMX512 starting address the user can set 66 separate ID addresses.
4. Set ID addresses in each fixture by setting panel function **{ID address}** to incremental values. (I.e. 1,2,3,4,5,6,etc...)
{MENU} ⇨ {Settings} ⇨ {ID address} ⇨ [01 ~ 66]
5. ID addresses are accessible using Channel 9 [Stage 1].

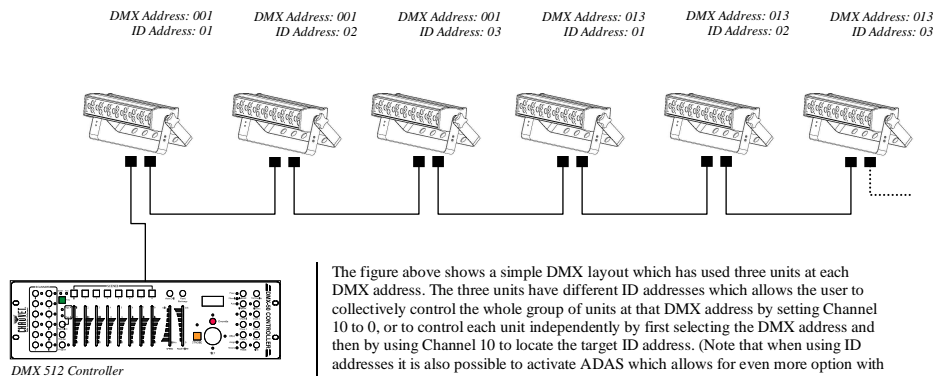

COLORcon™ Setup

1. FIXTURE CONTROL PANEL SETUP

Activate ID addressing in each fixture by setting panel function **{ID ON/OFF}** to ON.
{MENU} → **{Settings}** → **{ID ON/OFF}** → **[ON]**

Set ID addresses in each fixture by setting panel function **{ID address}** to incremental values. (I.e. 1,2,3,4,5,6,etc...)

{MENU} → **{Settings}** → **{ID address}** → **[01 ~ 66]**

It is not necessary to set the DMX address.

2. CONTROLLER SETUP

When using the **{Effect program}** function, it is necessary to set the **{Settings}** → **{Range}** setting, which is the quantity of fixtures in series.

{MENU} → **{Settings}** → **{Range}** → **[(No. of fixtures)]**

Single Row Application

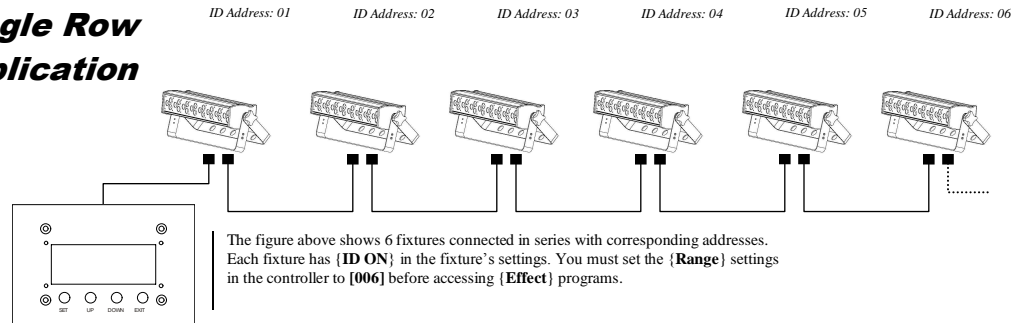

Repeat Row Block Application Block Application

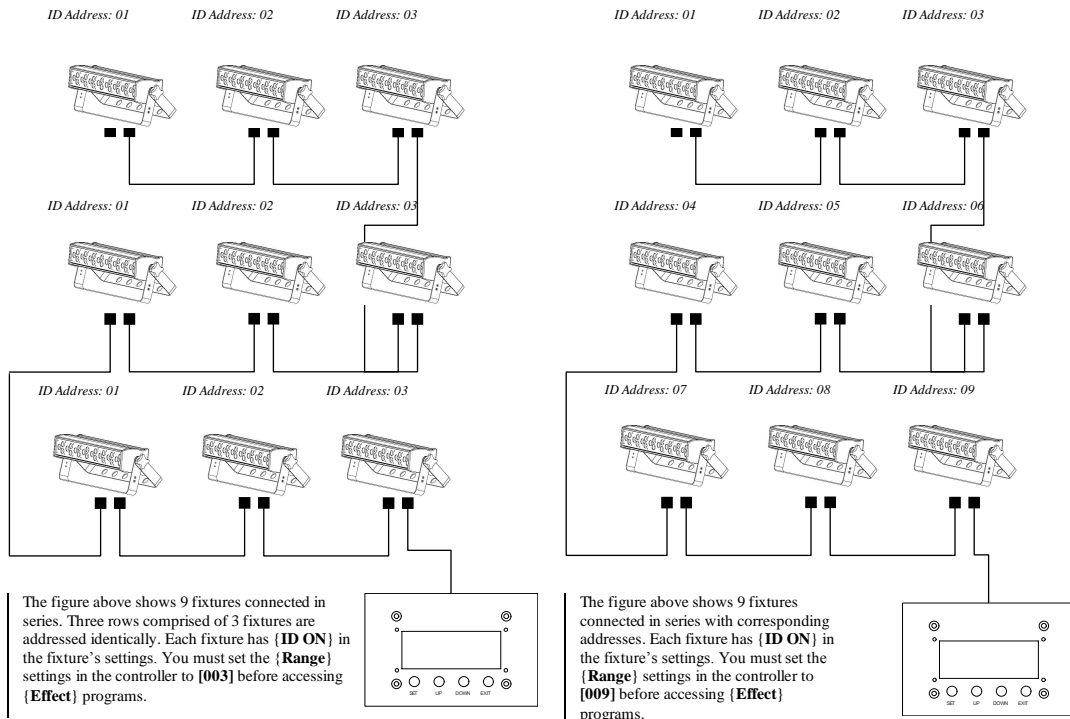

Setting the DMX address

Each fixture requires a "start address" from 1 to 512. A fixture requiring one or more channels for control begins to read the data on the channel indicated by the start address. For example, a fixture that occupies or uses 7 channels of DMX and was addressed to start on DMX channel 100, would read data from channels: 100, 101, 102, 103, 104, 105 and 106. Choose start addresses so that the channels used do not overlap and note the start address selected for future reference. The COLORdash™ Batten uses up to 12 channels of DMX. If this is your first time using DMX, we recommend reading the DMX Primer in the Appendix Section.

Control Panel Functions

All fixture functions and settings are accessible via the built-in control panel interface.

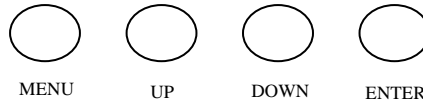

BUTTON	FUNCTION
MENU	Exits from the current menu or function
UP	Navigates upwards through the menu list and increases the numeric value when in a function
DOWN	Navigates downwards through the menu list and decreases the numeric value when in a function
ENTER	Enables the currently displayed menu or sets the currently selected value in to the selected function

Password Menu Lockout

The COLORdash™ Batten has a password lock-out feature. This can be enabled/disabled by using the Control Panel.

- **Note:** The pre-set user password is down + down + down + down + down + down + down + down. This may be changed by accessing the control panel.
 - However, if the user forgets their password, then there is a factory override permanent password of up+up+down+up+down+up+down+down.

Upload Customs



The custom programs in the COLORdash™ Batten may be copied from one fixture to another, thus giving the ability to have to only program them on a single fixture, and then duplicate this on several others. This is accessed in the Control Panel as “Upload”. Follow the below steps for this process. On all fixtures that are going to receive the upload, set them on SLAVE operation.

1. Disconnect from DMX controller
2. Select “Settings” in the Control Board and press Enter.
3. Select “Upload Customs” and press enter.
4. Press enter to confirm or enter password, then press enter. “Uploading customs” will display when the transfer is proceeding.
5. If the upload is successful, then the slave fixtures will show green. If the upload is unsuccessful, then the slave fixtures will show red.

Note: you must enter the password on the unit sending the custom programs to the other units. If you have not yet set a password on the unit, then you may leave it blank and just press “ENTER”.

Note: the units receiving the new custom programs from the master must be set to “SLAVE”. Otherwise, they will not allow receipt of the programs.

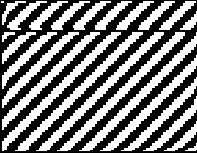
Menu Map

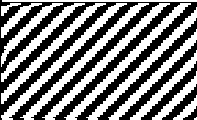
MAIN FUNCTION	SUB-FUNCTION	SELECTION	INSTRUCTION
1. Static Color	Red	000 ~ 255* (0 ~ 100%)	User can combine Red, Green and Blue to generate a custom color Select strobing frequency between 0 and 20Hz
	Green		
	Blue	*Strobe range is 0~20	
	Strobe		
2. Auto	Auto	(1~10)	Choose from 10 automatic programs
	Custom	(1~10)	Choose from 10 programs that be customized under the "edit custom" menu option
3. Edit Custom	Custom (1~10)	Red	User can combine Red, Green and Blue to generate a custom color (0~255)
		Green	
	-(Scene 01-30)	Blue	Select strobing frequency (0 ~20Hz)
		Strobe	
		Time	
Fade	(0~255)		
4. DMX Address		001 ~ 512	Sets the DMX starting address
5. Personality		Stage 1	9-channel
		Block	12-channel 4 section RGB
		Arc 1	3-channel RGB
		Arc 1+D	4-channel RGB+D
6. Run Mode		DMX~Slave	Sets the operating mode for the fixture: to receive signal from a DMX controller (DMX) or to receive signal from the DMX out of another COLORado Panel (Slave)
7. ID Address		0-66	Assigns the ID address to a fixture
8. Settings	Fan	Auto	Automatically turns on the fan, when needed
		Off	Keeps the fans off, regardless of the temperature. If the temperature of the LEDs reached a temperature >60°
		Low	Adjusts the fan speed to its quietest speed
		Normal	Adjusts the fan speed to it medium speed
		High	Adjusts the fan speed to its fastest speed
	ID	On~Off	Turns ID addressing on or off
	Reset to factory?	(Press enter 2 times)	Resets the fixture to the default, factory settings
Upload custom?	(Press enter 2 times) <i>Password Required</i>	Uploads a fixture's custom program to another fixture (same fixture only) <i>Password: Press Down 8 times</i>	
9. Password		On~Off	Turns the password on or off (after 30s of no action, the password will automatically turn on after selecting On)

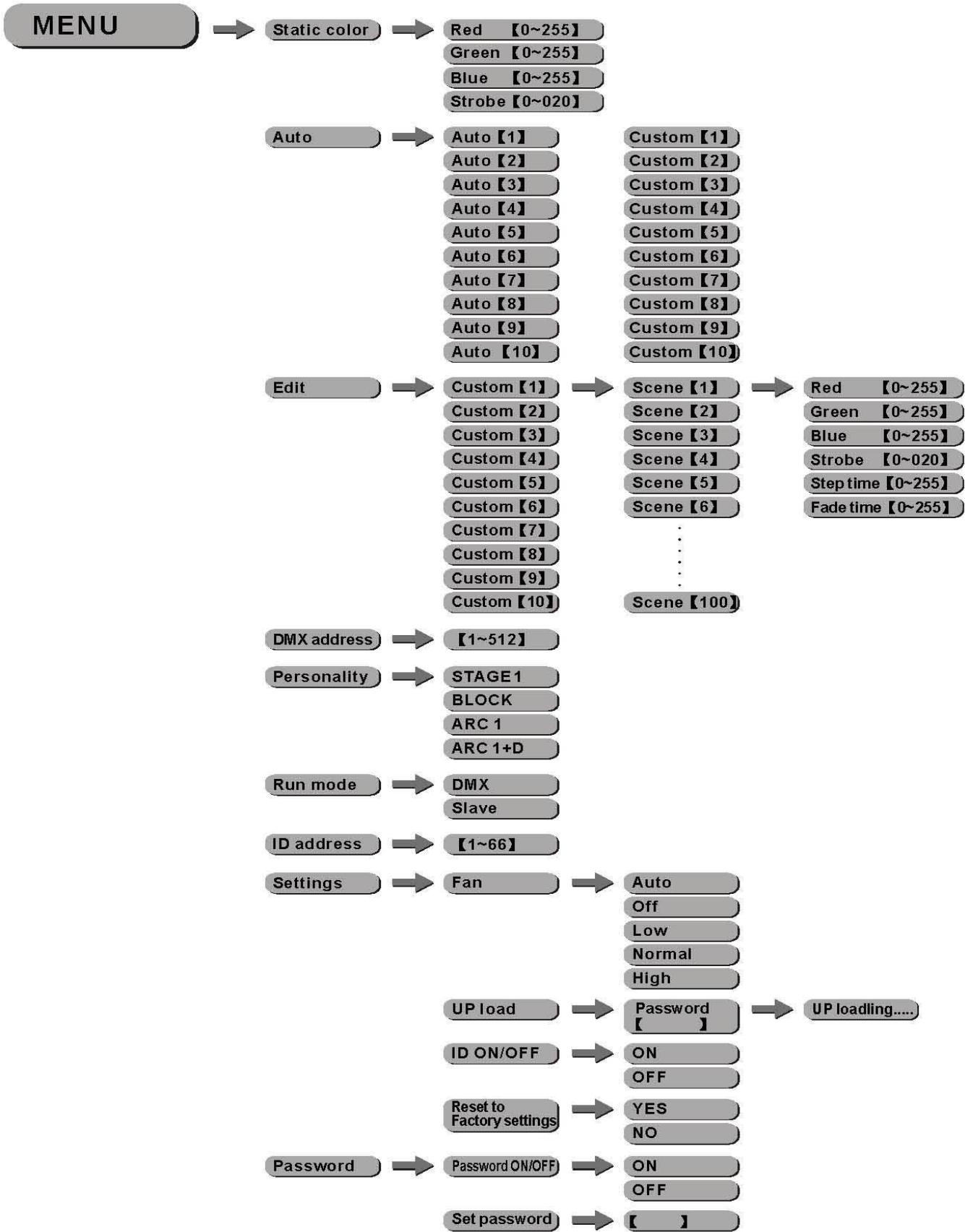

DMX512 Channel Values

The COLORdash™ Batten has 4 DMX512 channel configurations [STAGE1, BLOCK, ARC1, and ARC1+D].

STAGE 1

CHANNEL	VALUE	FUNCTION
1	000 ⇔ 255	Dimmer 0 ⇔ 100%
2	000 ⇔ 255	Red (or STEP TIME when CUS.01-10 is activated) 0 ⇔ 100%
3	000 ⇔ 255	Green (or FADE TIME when CUS.01-10 is activated) 0 ⇔ 100%
4	000 ⇔ 255	Blue 0 ⇔ 100%
5	000 ⇔ 010	Color Macro + White Balance No Function
	011 ⇔ 035	Red 100%/ Green Up/ Blue 0%
	036 ⇔ 060	Red Down/ Green 100%/ Blue 0%
	061 ⇔ 085	Red 0%/ Green 100%/ Blue Up
	086 ⇔ 110	Red 0%/ Green Down/Blue 100%
	111 ⇔ 135	Red Up/ Green 0%/Blue 100%
	136 ⇔ 160	Red 100%/ Green 0%/ Blue Down
	161 ⇔ 185	Red 100%/ Green Up/ Blue Up
	186 ⇔ 210	Red Down/ Green Down/ Blue 100%
	211 ⇔ 215	White 1:3200K
	216 ⇔ 220	White 2: 3400K
	221 ⇔ 225	White 3: 4200K
	226 ⇔ 230	White 4: 4900K
	231 ⇔ 235	White 5: 5600K
	236 ⇔ 240	White 6: 5900K
	241 ⇔ 245	White 7: 6500K
246 ⇔ 250	White 8: 7200K	
251 ⇔ 255	White 9: 8500K	
6	000 ⇔ 004	Strobe No Function
	005 ⇔ 255	0 ⇔ 20Hz
7	000 ⇔ 010	Auto + Custom Programs + Fan Control Reset to display fan setting
	011 ⇔ 020	Fans Off (Hold for 3 sec)
	021 ⇔ 030	Fans Low (Hold for 3 sec)
	031 ⇔ 040	Fans Normal (Hold for 3 sec)
	041 ⇔ 050	Fans High (Hold for 3 sec)
	051 ⇔ 060	Fans Auto (Hold for 3 sec)
	061 ⇔ 070	Auto 1
	071 ⇔ 080	Auto 2
	081 ⇔ 090	Auto 3
	091 ⇔ 100	Auto 4
	101 ⇔ 110	Auto 5
	111 ⇔ 120	Auto 6
	121 ⇔ 130	Auto 7
	131 ⇔ 140	Auto 8
	141 ⇔ 150	Auto 9
	151 ⇔ 160	Auto 10
	161 ⇔ 170	Custom 1
	171 ⇔ 180	Custom 2
	181 ⇔ 190	Custom 3
	191 ⇔ 200	Custom 4
201 ⇔ 210	Custom 5	
211 ⇔ 220	Custom 6	
221 ⇔ 230	Custom 7	
231 ⇔ 240	Custom 8	
241 ⇔ 250	Custom 9	
251 ⇔ 255	Custom 10	

8	0 ⇔ 255	Auto Speed
CHANNEL 9 (ID ADDRESS SELECTION)		
000 ⇔ 009	All IDs	ID 23
010 ⇔ 019	ID 1	ID 24
020 ⇔ 029	ID 2	ID 25
030 ⇔ 039	ID 3	ID 26
040 ⇔ 049	ID 4	ID 27
050 ⇔ 059	ID 5	ID 28
060 ⇔ 069	ID 6	ID 29
070 ⇔ 079	ID 7	ID 30
080 ⇔ 089	ID 8	ID 31
090 ⇔ 099	ID 9	ID 32
100 ⇔ 109	ID 10	ID 33
110 ⇔ 119	ID 11	ID 34
120 ⇔ 129	ID 12	ID 35
130 ⇔ 139	ID 13	ID 36
140 ⇔ 149	ID 14	ID 37
150 ⇔ 159	ID 15	ID 38
160 ⇔ 169	ID 16	ID 39
170 ⇔ 179	ID 17	ID 40
180 ⇔ 189	ID 18	ID 41
190 ⇔ 199	ID 19	ID 42
200 ⇔ 209	ID 20	ID 43
210	ID 21	ID 44
211	ID 22	ID 45
		235
		236
		237
		238
		239
		240
		241
		242
		243
		244
		245
		246
		247
		248
		249
		250
		251
		252
		253
		254
		255
		ID 46
		ID 47
		ID 48
		ID 49
		ID 50
		ID 51
		ID 52
		ID 53
		ID 54
		ID 55
		ID 56
		ID 57
		ID 58
		ID 59
		ID 60
		ID 61
		ID 62
		ID 63
		ID 64
		ID 65
		ID 66

10	Block
000 ⇔ 009	Block 1,2,3,4
010 ⇔ 029	Block 1
030 ⇔ 049	Block 2
050 ⇔ 069	Block 3
070 ⇔ 089	Block 4
090 ⇔ 109	Block 1,2
110 ⇔ 129	Block 3,4
130 ⇔ 149	Block 1,4
150 ⇔ 169	Block 2,3
170 ⇔ 189	Block 1,2,3
190 ⇔ 209	Block 2,3,4
210 ⇔ 229	Block 1,3,4
230 ⇔ 255	Block 1,2,4

BLOCK

CHANNEL	VALUE	FUNCTION
1	000 ⇔ 255	Red 1 0 ⇔ 100%
2	000 ⇔ 255	Green 1 0 ⇔ 100%
3	000 ⇔ 255	Blue 1 0 ⇔ 100%
4	000 ⇔ 255	Red 2 0 ⇔ 100%
5	000 ⇔ 255	Green 2 0 ⇔ 100%
6	000 ⇔ 255	Blue 2 0 ⇔ 100%
7	000 ⇔ 255	Red 3 0 ⇔ 100%
8	000 ⇔ 255	Green 3 0 ⇔ 100%
9	000 ⇔ 255	Blue 3 0 ⇔ 100%
10	000 ⇔ 255	Red 4 0 ⇔ 100%
11	000 ⇔ 255	Green 4 0 ⇔ 100%
12	000 ⇔ 255	Blue 4 0 ⇔ 100%

ARC 1

CHANNEL	VALUE	FUNCTION
1	000 ⇔ 255	Red 0 ⇔ 100%
2	000 ⇔ 255	Green 0 ⇔ 100%
3	000 ⇔ 255	Blue 0 ⇔ 100%

ARC 1 + D

CHANNEL	VALUE	FUNCTION
1	000 ⇔ 255	Dimmer 0 ⇔ 100%
2	000 ⇔ 255	Red 0 ⇔ 100%
3	000 ⇔ 255	Green 0 ⇔ 100%
4	000 ⇔ 255	Blue 0 ⇔ 100%

Important Notes about STAGE 1 DMX Operation

MASTER DIMMER

- Channel 1 controls the intensity of the currently projected color
- When the slider is at the highest position (255), then the intensity of the output is at the maximum.

RED, GREEN BLUE AND WHITE COLOR SELECTION

- Channels 2, 3 4 and 5 control the intensity ratio of each of the Red, Green, & Blue LEDs.
- Channels 2 3 and 4 can be combined together to create over 16 million color combinations.

STROBE

- Channel 7 controls the strobe of Channels 2 through 4.
- Channel 7 has priority over Channels 2, 3, & 4.
- Speed of the strobe is adjustable from 0 to 20 Hz.

COLOR MACROS

- Channel 6 selects the Color Macro.
- Channel 6 has priority over Channels 2, 3, 4, 5 & 7.
- Channel 1 is used to control the intensity of the current Color Macro.

ID ADDRESS SELECTION

- Use channel 9 to select the target ID address.
- Each independent DMX address can have up to 66 ID addressed fixtures.
- ID address "0" allows control of all fixtures simultaneously.

AUTO & CUSTOM PROGRAMS

- Channel 7 selects the preset Auto/Custom programs 1~10
- When activating the Auto/Custom programs, it is then possible to control the Step time and Fade time by using Channels 2 & 3 respectively.

BLOCK

- This fixture is divided into 4 sections. Channel 10 determines your block selection.

5. COLORADO™ CONTROLLER

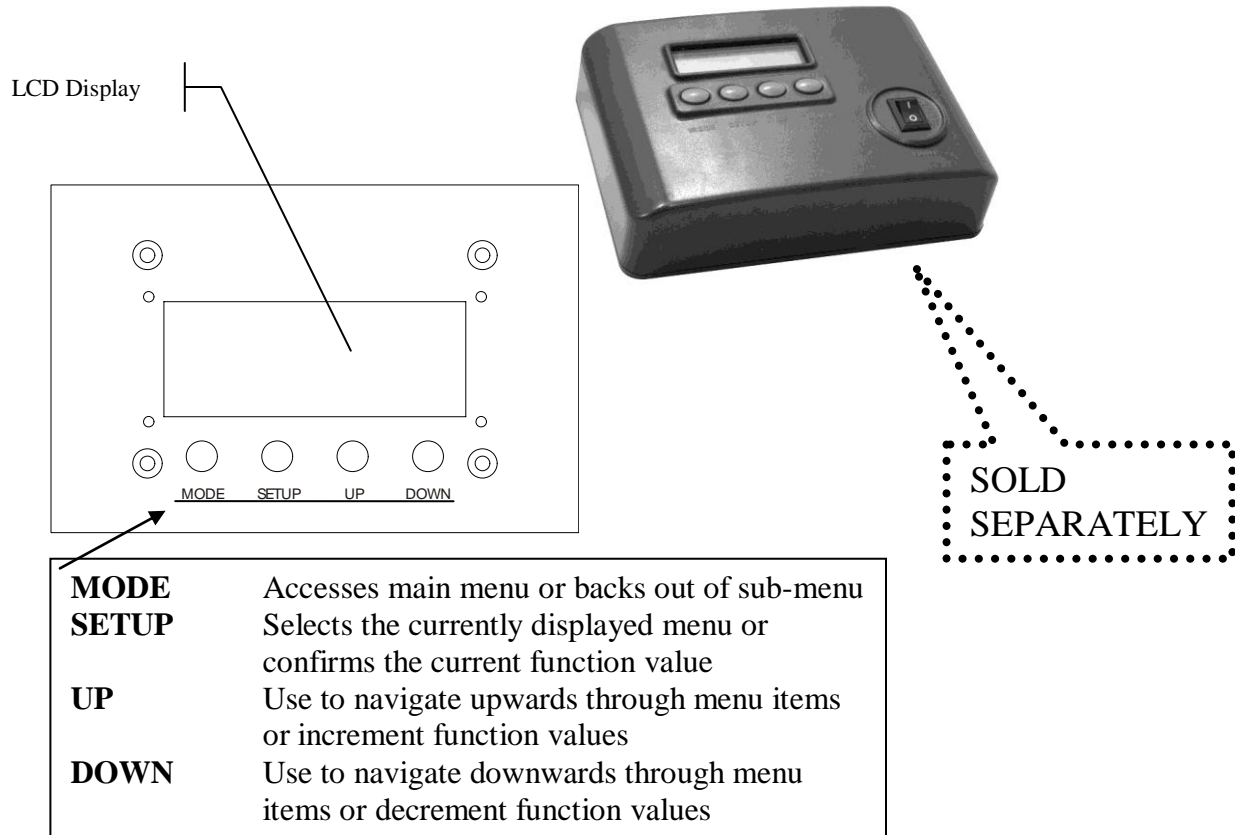

Overview

Setup

1. Connect from the OUT on the controller to the DMX Input side of the fixture using a DMX XLR cable.
2. It is recommended that you power up all COLORado units connected prior to turning on the controller. This ensures that the controller will auto-detect DMX addresses. Alternatively you can use **{Detect device}** from the **{Settings}** menu.
3. Set ID addresses on the fixtures in ascending order.
4. Set the **{Range}** in the **{Settings}** menu.

Note There is no need to set ID and Range for **{Wash}** programs.

Menu Map

MAIN FUNCTION	SELECTION	SELECTION	SELECTION	SELECTION
Wash program	Wash [1] ⇄ Wash [8]	Edit	Step time [001] ⇄ [255]	
			Fade time [001] ⇄ [255]	
Effect program	Effect [1] ⇄ Effect [8]	Edit	Speed [001] ⇄ [100]	
Custom program	Custom [1] ⇄ Custom [8]	Edit	Scene [1] ⇄ Scene [100]	ID address [000*] ⇄ [100] (*0 = all units)
				Step time [000] ⇄ [255]
				Fade time [000] ⇄ [255]
				Red [000] ⇄ [255]
				Green [000] ⇄ [255]
				Blue [000] ⇄ [255]
				Module [001] ⇄ [006]
Strobe [000] ⇄ [020]				
Play schedule	Schedule			
Clock	Time now	i.e. 12/31/2006 13:50:24		
	Edit time	i.e. 12/31/2006 13:50:24		
Schedule	Wash [1] ⇄ Wash [8]	Start>>>End 00:00>>>00:00		
	Effect [1] ⇄ Effect [8]			
	Custom [1] ⇄ Custom [8]			
Settings	DMX address	[001] ⇄ [255]		
	Range	[001] ⇄ [066]		
	Allow edit	[YES] ⇄ [NO]		
	Detect device	>>>		
	Reset to Factory settings	[YES] ⇄ [NO]		
Password	Password ON/OFF	[ON] ⇄ [OFF]		
	Set password	[]		

Wash Program

1. Select from the eight existing **[Wash]** programs and it will instantly play.
2. Set the **[Step time]** and the **[Fade time]** in the **[Edit]** function if desired.
3. The unit of time is 5 seconds and it can be adjusted between 1 and 255.

Effect Program

1. Select from the eight existing **[Effect]** programs and it will instantly play.
2. Vary the **[Speed]** of the effect between 1 and 255.

Custom Program

1. Select from the eight existing **[Custom]** programs and it will instantly play.
2. Enter the **[Edit]** section to create or edit program.
3. You can create or edit up to 100 scenes. To program less than 100 scenes, set the **[Step time]** of the scene **after** your last scene to 0.
4. Select the ID address of the target unit. Setting ID address to 0 selects all units in the serial link. Color/Effects combination for different IDs is allowed.
5. Specify the **[Module]** or modules to run active.
Note: this option is intended for use with the COLORado 3; for the COLORado 1, it will function as if **[Module]** is set to one.
0 = 1,2,3
1 = 1
2 = 2
3 = 3
4 = 1,2
5 = 2,3
6 = 1,3
6. RGB mix using the **[Red]**, **[Green]** and **[Blue]** functions and adjusting the range between 0 and 255.
7. Select a **[Strobe]** speed from 0-20Hz if desired.
8. Select the **[Step time]** for the current scene.
Step time unit values
Range 0 – 10 = 0.1sec per unit
Range 11 – 255 = 1 sec per unit
9. Set a **[Fade time]** for the current scene in one second increments from 0 to 255.

Play Schedule

Simply activate this menu **[Play schedule]** to run.

Clock

[Clock] ⇨ **[Time now]**: To view the current time on the controller.

[Clock] ⇨ **[Edit now]**: Edit the time and date.

Schedule

There are 24 **Wash**, **Effect** and **Custom** programs that can be set with Start and End times. Start times take priority over End times. Programs will not overlap. Programs with the most recent Start time will always override the existing previously executed program.

Settings

[DMX address]

This function sets the DMX address for the controller. It is addressable from 1 to 250.

[Range]

Enter the number of fixtures connected in series.

[Allow edit]

This function either enables or disables editing in **Wash**, **Effect** and **Custom** programs.

[Detect device]

This is the manual method of detecting and connecting the controller to all new units in series. It is generally used when you add more units to an existing system. Turning off and then on the controller has the same effect.

[Reset to factory settings]

This function will reset all the settings to the factory defaults except for [Custom] programs.

Factory Default Settings	
Setting	Default
[Schedule]	All times in schedule are reset to [00:00]
[Wash program]	Step times and fade times are reset to [001]
[Effect program]	Speeds are reset to [001]
[DMX address]	DMX address is reset to [001]
[Range]	Range is reset to [066]
[Allow edit]	Reset to [Yes]
[Password ON/OFF]	Password is reset to [OFF]
[Set password]	Password is reset to [00000000] Down=0, Up=1

Activating password mode

1. Set [Password] function to [ON]. This will prompt the user for a password every time the controller is powered on.
2. Toggle to [Set password] function in order to change the password.
3. Input an 8 digit password using the [UP] & [DOWN] keys. Press the [SET] button to confirm.

Note In the event that the user forgets the password use the following factory password override:

[UP] ↻ [DOWN] ↻ [UP] ↻ [DOWN] ↻ [UP] ↻ [UP] ↻ [DOWN] ↻ [DOWN]

Control via external DMX

Programs in the controller can be accessed via an external DMX controller. It will be necessary to have the DMX address set on the COLORado Controller. The controller operates on 4 channels of control.

DMX Channel Values

CHANNEL	VALUE	FUNCTION
1	000 ⇔ 010	Blackout
	011 ⇔ 030	Wash [1]
	031 ⇔ 040	Blackout
	041 ⇔ 060	Wash [2]
	061 ⇔ 070	Blackout
	071 ⇔ 090	Wash [3]
	091 ⇔ 100	Blackout
	101 ⇔ 120	Wash [4]
	121 ⇔ 130	Blackout
	131 ⇔ 150	Wash [5]
	151 ⇔ 160	Blackout
	161 ⇔ 180	Wash [6]
	181 ⇔ 190	Blackout
	191 ⇔ 210	Wash [7]
	211 ⇔ 220	Blackout
	221 ⇔ 255	Wash [8]
2	000 ⇔ 010	Blackout
	011 ⇔ 030	Effect [1]
	031 ⇔ 040	Blackout
	041 ⇔ 060	Effect [2]
	061 ⇔ 070	Blackout
	071 ⇔ 090	Effect [3]
	091 ⇔ 100	Blackout
	101 ⇔ 120	Effect [4]
	121 ⇔ 130	Blackout
	131 ⇔ 150	Effect [5]
	151 ⇔ 160	Blackout

	161 ⇔ 180	Effect [6]
	181 ⇔ 190	Blackout
	191 ⇔ 210	Effect [7]
	211 ⇔ 220	Blackout
	221 ⇔ 255	Effect [8]
3	000 ⇔ 010	Blackout
	011 ⇔ 030	Custom [1]
	031 ⇔ 040	Blackout
	041 ⇔ 060	Custom [2]
	061 ⇔ 070	Blackout
	071 ⇔ 090	Custom [3]
	091 ⇔ 100	Blackout
	101 ⇔ 120	Custom [4]
	121 ⇔ 130	Blackout
	131 ⇔ 150	Custom [5]
	151 ⇔ 160	Blackout
	161 ⇔ 180	Custom [6]
	181 ⇔ 190	Blackout
191 ⇔ 210	Custom [7]	
211 ⇔ 220	Blackout	
221 ⇔ 255	Custom [8]	
4	000 ⇔ 127	OFF
	128 ⇔ 255	ON

Technical Support

Address: Service Dept.
 3000 N 29th Ct, Hollywood, FL 33020 (U.S.A.)
 Support (Email): tech@chauvetlighting.com
 Telephone: (954) 929-1115 - (Press 4)
 Fax: (954) 929-5560 - (Attention: Service)
 Website: <http://www.chauvetlighting.com>

Contact Us

World Wide

General Information

Chauvet Lighting
 3000 North 29th Court
 Hollywood, FL 33020
 voice: 954.929.1115
 fax: 954.929.5560
 toll free: 800.762.1084)

World Wide Web

www.chauvetlighting.com

6. APPENDIX

DMX Primer

There are 512 channels in a DMX-512 connection. Channels may be assigned in any manner. A fixture capable of receiving DMX 512 will require one or a number of sequential channels. The user must assign a starting address on the fixture that indicates the first channel reserved in the controller. There are many different types of DMX controllable fixtures and they all may vary in the total number of channels required. Choosing a start address should be planned in advance. Channels should never overlap. If they do, this will result in erratic operation of the fixtures whose starting address is set incorrectly. You can however, control multiple fixtures of the same type using the same starting address as long as the intended result is that of unison movement or operation. In other words, the fixtures will be slaved together and all respond exactly the same.

DMX fixtures are designed to receive data through a serial Daisy Chain. A Daisy Chain connection is where the DATA OUT of one fixture connects to the DATA IN of the next fixture. The order in which the fixtures are connected is not important and has no effect on how a controller communicates to each fixture. Use an order that provides for the easiest and most direct cabling. Connect fixtures using shielded two conductor twisted pair cable with three pin XLR male to female connectors. The shield connection is pin 1, while pin 2 is Data Negative (S-) and pin 3 is Data positive (S+). CHAUVET carries 3-pin XLR DMX compliant cables, DMX-10 (33'), DMX-4.5 (15') and DMX-1.5 (5')

General Maintenance

To maintain optimum performance and minimize wear fixtures should be cleaned frequently. Usage and environment are contributing factors in determining frequency. As a general rule, fixtures should be cleaned at least twice a month. Dust build up reduces light output performance and can cause overheating. This can lead to reduced lamp life and increased mechanical wear. Be sure to power off fixture before conducting maintenance.

Unplug fixture from power. Use a vacuum or air compressor and a soft brush to remove dust collected on external vents and internal components. Clean all glass when the fixture is cold with a mild solution of glass cleaner or Isopropyl Alcohol and a soft lint free cotton cloth or lens tissue. Apply solution to the cloth or tissue and drag dirt and grime to the outside of the lens. Gently polish optical surfaces until they are free of haze and lint.

The cleaning of internal and external optical lenses and/or mirrors must be carried out periodically to optimize light output. Cleaning frequency depends on the environment in which the fixture operates: damp, smoky or particularly dirty surrounding can cause greater accumulation of dirt on the unit's optics. Clean with soft cloth using normal glass cleaning fluid. - Always dry the parts carefully. - Clean the external optics at least every 20 days. Clean the internal optics at least every 30/60 days.

Returns Procedure

Returned merchandise must be sent prepaid and in the original packing, call tags will not be issued. Package must be clearly labeled with a Return Merchandise Authorization Number (RA #). Products returned without an RMA # will be refused. Call CHAUVET and request RA # prior to shipping the fixture. Be prepared to provide the model number, serial number and a brief description of the cause for the return. Be sure to properly pack fixture, any shipping damage resulting from inadequate packaging is the customer's responsibility. CHAUVET reserves the right to use its own discretion to repair or replace product(s). As a suggestion, proper UPS packing or double-boxing is always a safe method to use.

Note: If you are given an RMA #, please include the following information on a piece of paper inside the box:

- 1) Your name
- 2) Your address
- 3) Your phone number
- 4) The RMA #
- 5) A brief description of the symptoms

Claims

Damage incurred in shipping is the responsibility of the shipper; therefore the damage must be reported to the carrier upon receipt of merchandise. It is the customer's responsibility to notify and submit claims with the shipper in the event that a fixture is damaged due to shipping. Any other claim for items such as missing component/part, damage not related to shipping, and concealed damage, must be made within seven (7) days of receiving merchandise.

Photometrics

RED

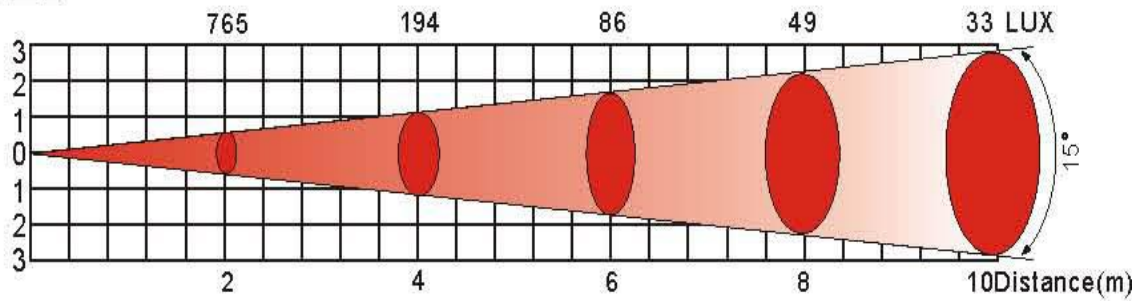

GREEN

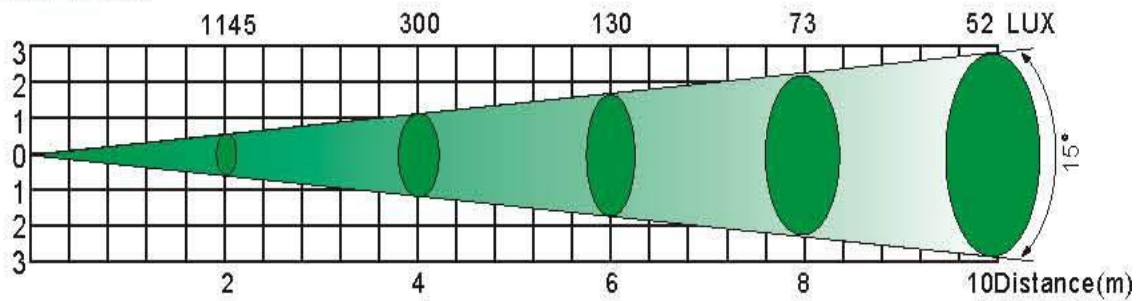

BLUE

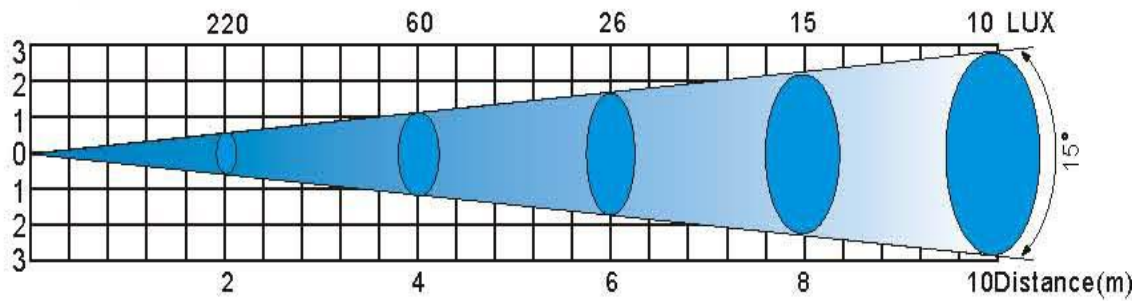

RGB

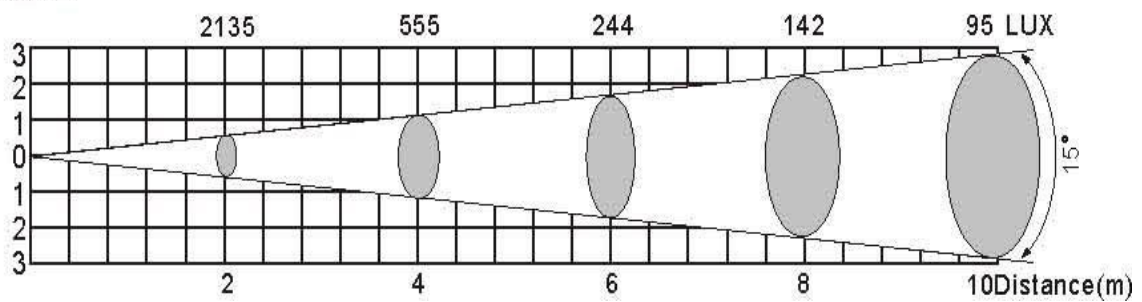

COLORdash™ Batten Service Maintenance Guide

Symptom(s)	Possible Solution(s)
1 or more LED's are not illuminating	Clean the fixture regularly to avoid any such failure. This fixture is convection cooled, which means that if the surface is kept clean and free of debris, then proper cooling will be allowed to occur
	An LED may have failed, resulting in an open circuit. In this event, all of the red, green, or blue in a single module will no longer illuminate. This does not mean that all of the LEDs have failed, but the circuit is wired in series.
	An LED may have failed, resulting in a short circuit. In this event, only the single LED which has failed will no longer function. This does not mean that all of the LEDs have failed, but the circuit is wired in series.
	<i>-Note: In the event of LED failure, a replacement LED PCB assembly may be purchased directly from Chauvet Part#: P222-MBATDVR</i>
1 or more LED's are producing very low output	Check that the lens assembly is installed properly. If the lens assembly is not aligned properly over the LEDs, then they will not project fully <i>-See section on Lens Assembly Installation</i>
	<i>-Note: In the event of LED failure, a replacement LED PCB assembly may be purchased directly from Chauvet Part#: P222-MBATDVR</i>
Breaker/Fuse keeps blowing	Check total load placed on the electrical circuit
	Check for a short in the electrical wiring: internal and/or external
Device has no power	Check device's fuse (internal)
	Check for power on Mains
	Check cable connections The MiniPar cables must be firmly connected for operation
	<i>-Note: In the event of autoswitching transformer failure, the unit can be sent in for repair; however, a replacement part can be ordered directly from Chauvet Part#: P140-M1ELTR</i>
Fixture is not responding to DMX	Check Control Panel settings for correct addressing
	Check DMX cables
	Check polarity switch settings on the controller
	Check cable connections
	Call service technician
	<i>-Note: In the event of Master PCB failure, a replacement PCB can be ordered directly from Chauvet Part#: P170-MBATPC</i>
Loss of signal	Use only DMX cables
	Install terminator
	Note: Keep DMX cables separated from power cables or black lights
COLOR-CON Controller does not function, or does not function properly	Make sure connector is firmly connected to device
	The MiniPar fixture must be in the correct mode in order to properly respond to the COLOR-CON controller. The correct mode is "SLAVE" in the onboard Control Panel
Stand alone operation	This fixture has built-in, automatic programs that may be triggered from the onboard Control Panel

If you still have a problem after trying the above solutions, please contact CHAUVET Technical Support at the location on page 28.

Blow-out Diagram.

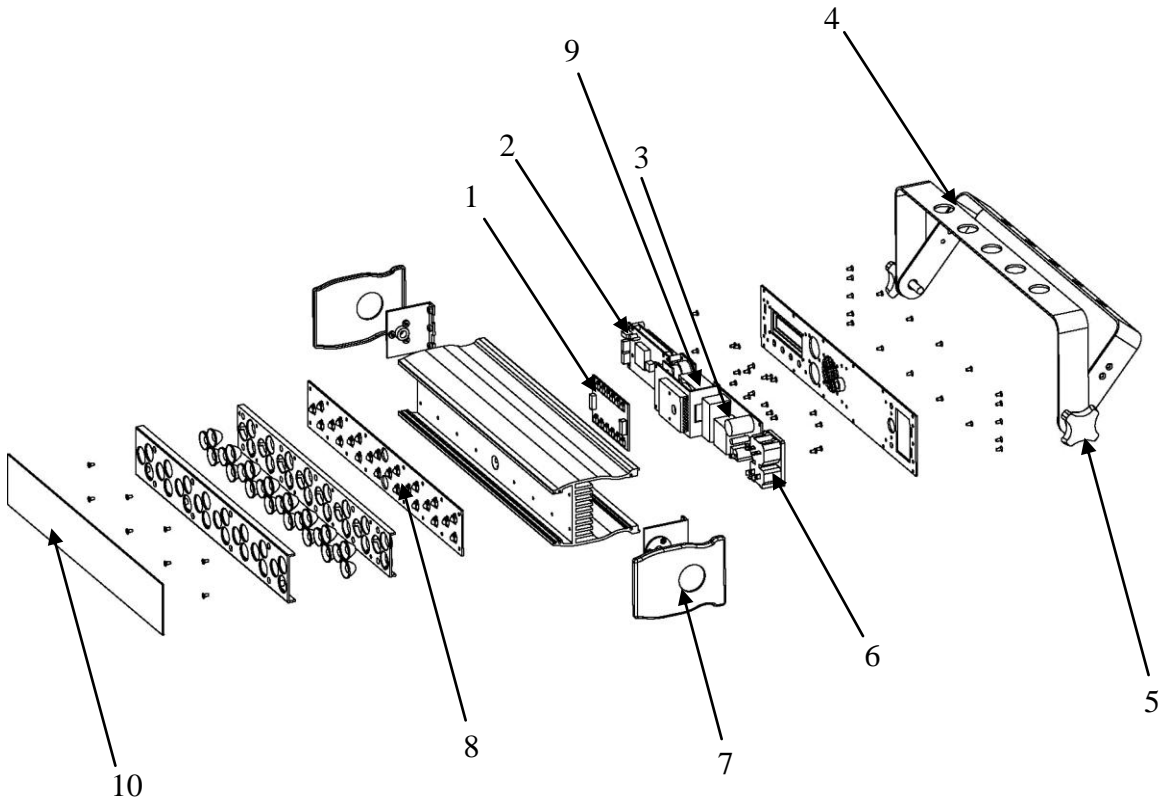

	Description	Part Number
1	LED Driver PCB	P172-MBTDVR
2	Display/Master PCB	P170-MBATPC
3	Electronic Transformer 90-240V 50/60Hz	P140-M1ELTR
4	Bracket/Floor stand	P170-MBBRKT
5	Bracket adjustment knob	P111-MBTKNOB
6	Power input/output connector	P111-PWRCNC
7	Side, plastic cover	P111-BATBCVR
8	LED metal-core PCB assembly	P222-MBATDVR
9	Cooling fan	P130-40MM24V
10	Front clear plastic LED cover	P111-MBARCLR

Connection Drawing

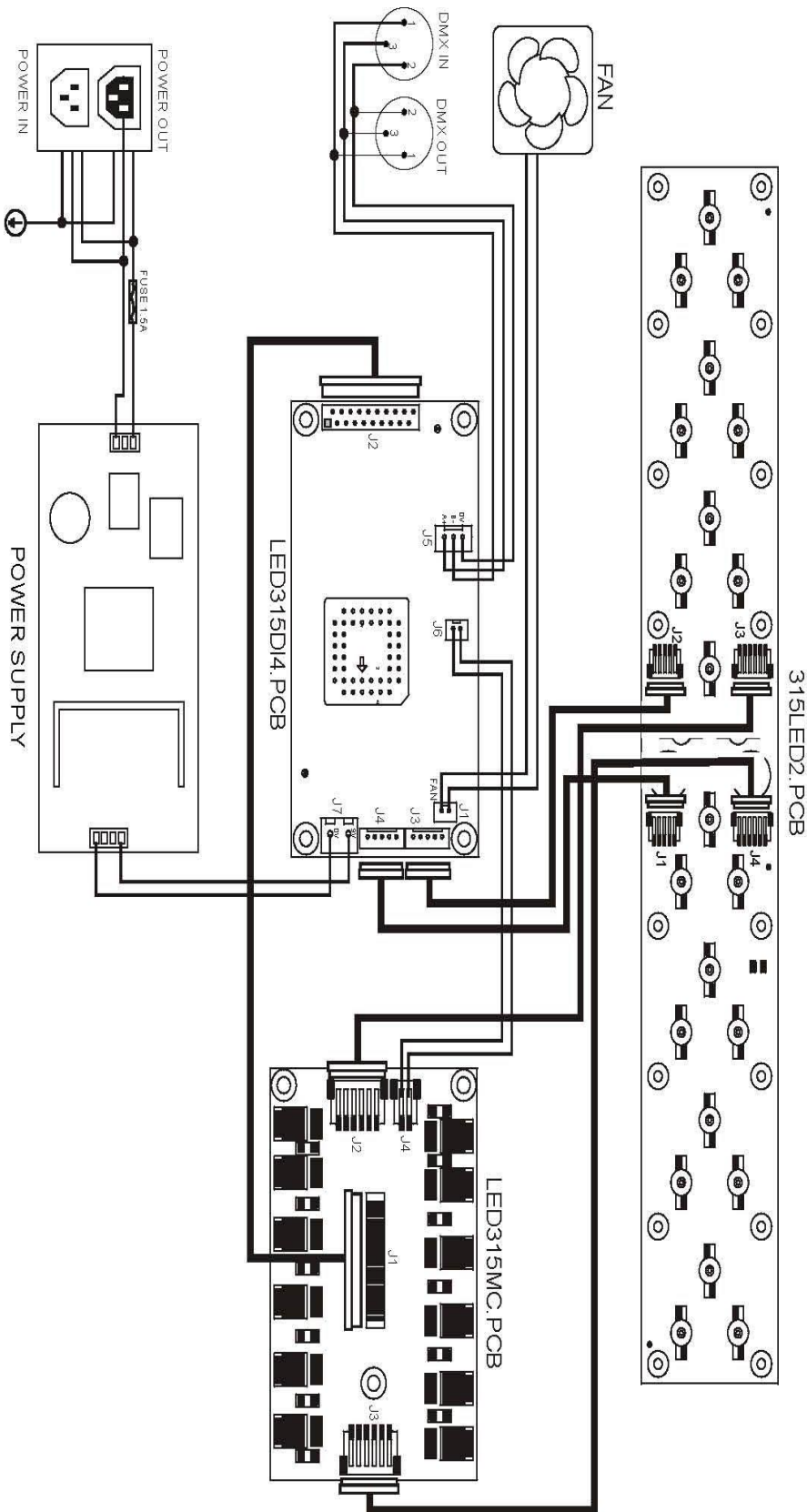

Technical Specifications

WEIGHT & DIMENSIONS

Length.....	3.3 in (84 mm)
Width.....	18.5 in (470 mm)
Height.....	7.5 in (191 mm)
Weight.....	7.9 lbs (3.6 kg)

POWER

AC Power Auto-switching	100V~240V 50/60Hz AC
Power Consumption	58W (0.8A) max at 120V 60Hz
Power Consumption	59W (0.46A) max at 240V 60Hz
Inrush Current	1.6A at 120V 60Hz
Power Factor.....	0.64 at 120V 60Hz
Power Factor.....	0.47 at 240V 60Hz
Additional Power Output	13 units max @120V
Additional Power Output	23 units max @240V

LIGHT SOURCE

Quantity.....	24 (8 Red, 8 Green, 8 Blue)
LED.....	1W 350mA 50,000 hrs

PHOTO OPTIC (WITH 30° LENSES)

Luminance @ 1m	1,750 lux
Beam Angle.....	35° x 30°
Field Angle	62° x 60°

COOLING

Forced convection cooling	40mm 24V fan
---------------------------------	--------------

CONTROL & PROGRAMMING

Data input.....	locking 3-pin XLR male socket
Data output.....	locking 3-pin XLR female socket
Data pin configuration.....	pin 1 shield, pin 2 (-), pin 3 (+)
Protocols	DMX-512 USITT
DMX Channels	User Configurable: 3, 4, 10, or 12

STANDARD ORDERING INFORMATION

COLORdash™ Batten	COLORDASHBATTEN
15° Optical Lens kit (20pcs)	CL20X15
30° Optical Lens kit (20pcs)	installed
Power extension cable.....	EXT-2

SPARE PARTS ORDERING INFORMATION

Electronic Transformer (Part).....	P140-M1ELTR
Display/Master PCB (Part).....	P170-MBATPC
LED Driver PCB (Part).....	P172-MBTDVR
LED Metal-Core PCB: assembled (Part)	P222-MBLEDP
Front Lens Replacement UV-coated Cover (Part)	P111-MBTCVR
Bracket/floor stand assembly (Part)	P111-MBTBRKT
Display/Master IC chip (Part)	P177-MBATIC
Bracket adjustment knob (Part).....	P111-MBKNOB
Red 1W 350mA LED SINGLE (Part).....	P222-CORLED
Green 1W 350mA LED SINGLE (Part).....	P222-COGLLED
Blue 1W 350mA LED SINGLE (Part)	P222-COBLED
Cooling fan (Part)	P130-40MM24V
Side black plastic cover (X2) (Part)	P111-MBBCVR
Clear LED plastic cover (X2) (Part)	P111-MBTCVR

OPTIONAL CONTROLLER

COLORado™ Controller.....	COLOR-CON
---------------------------	-----------

WARRANTY INFORMATION

Warranty	2-year limited warranty
----------------	-------------------------