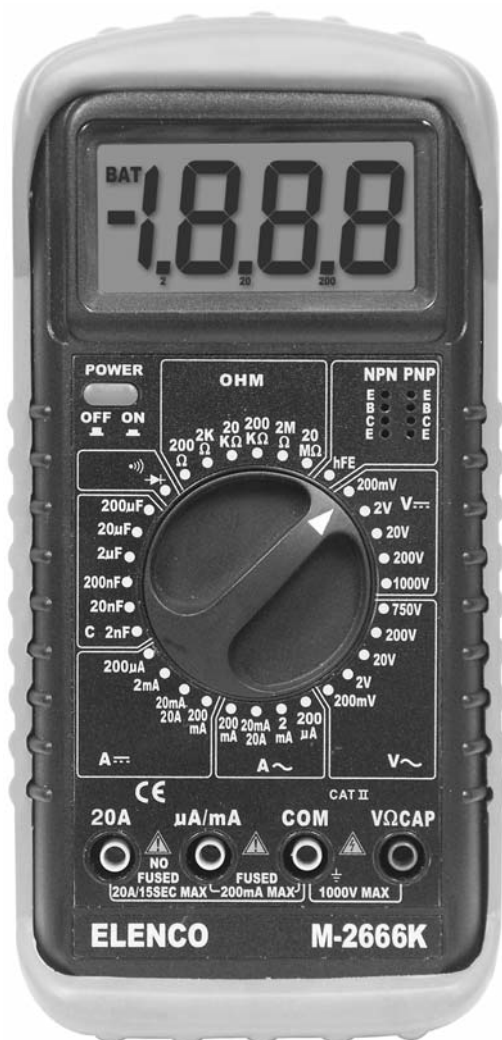


# DIGITAL MULTIMETER KIT

## MODEL M-2666K WIDE RANGE DIGITAL MULTIMETER WITH CAPACITANCE AND TRANSISTOR TESTING FEATURES



### Assembly and Instruction Manual

# Elenco<sup>®</sup> Electronics, Inc.

## INTRODUCTION

Assembly of your M-2666K Digital Multimeter Kit will prove to be an exciting project and give much satisfaction and personal achievement. If you have experience in soldering and wiring technique, you should have no problems. For the beginner, care must be given to identifying the proper components and in good soldering habits. Above all, take your time and follow the easy step-by-step instructions. Remember, "An ounce of prevention is worth a pound of cure".

The meter kit has been divided into a number of sections to make the assembly easy and avoid major problems with the meter operation.

Section A - Meter display circuit assembly.

Section B - DC voltage and current circuit assembly.

Section C - AC voltage and current circuit assembly.

Section D - Resistance & buzzer circuit assembly.

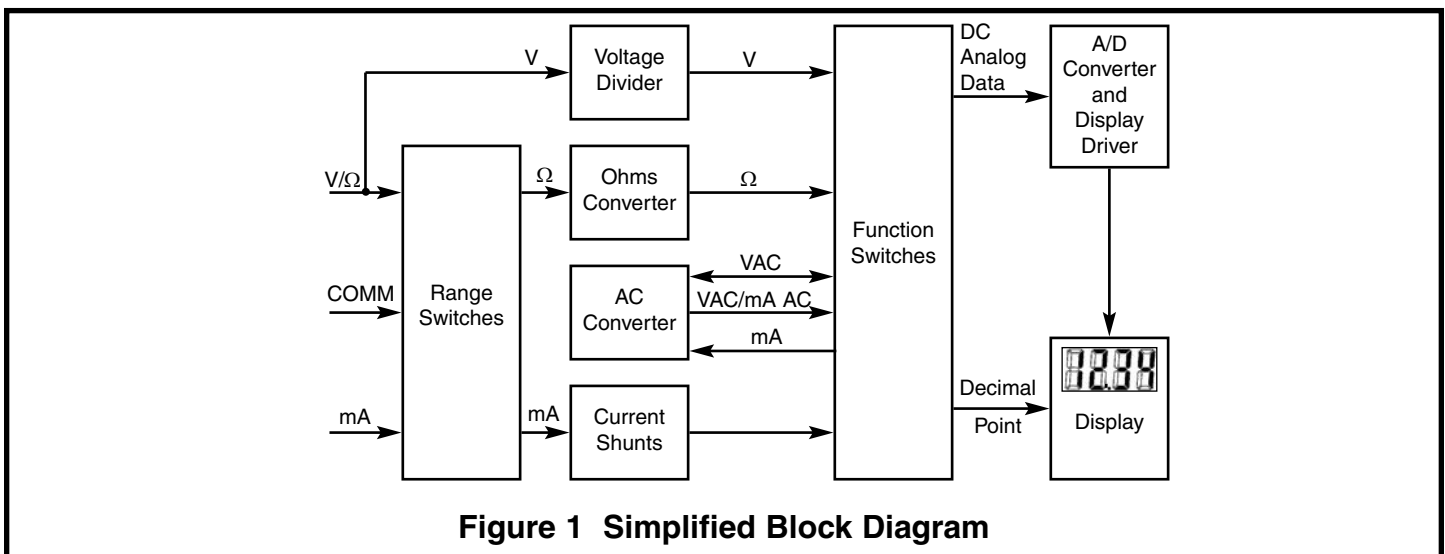
Section E - Capacitance and transistor testing circuit assembly.

Section F - Final assembly.

## THEORY OF OPERATION

A block diagram of the M-2666K is shown in Figure 1. Operation centers around a custom LSI chip. This IC contains a dual slope A/D converter, display, latches, decoder and the display driver. A block diagram of the IC functions is shown in Figure 6. The input voltage, current or ohm signals are conditioned by the function and selector switches to produce and output DC voltage between 0 and +199mV. If the input signal

is 100VDC, it is reduced to 100mVDC by selecting a 1000:1 divider. Should the input be 100VAC, then after the divider it is processed by the AC converter to produce 100mVDC. If current is to be read, it is converted to a DC voltage via internal shunt resistors. For resistance measurements, an internal voltage source supplies the necessary 0-199mV voltage to be fed to the IC input.



**Figure 1 Simplified Block Diagram**

The input of the 7106 IC is fed to an A/D (analog to digital) converter. Here the DC voltage amplitude is changed into a digital format. The resulting signals are processed in the decoders to light the appropriate LCD segment.

Timing for the overall operation of the A/D converter is derived from an external oscillator whose frequency is selected to be 40kHz. In the IC, this

frequency is divided by four before it clocks the decade counters. It is further divided to form the three convert-cycle phases. The final readout is clocked at about three readings per second.

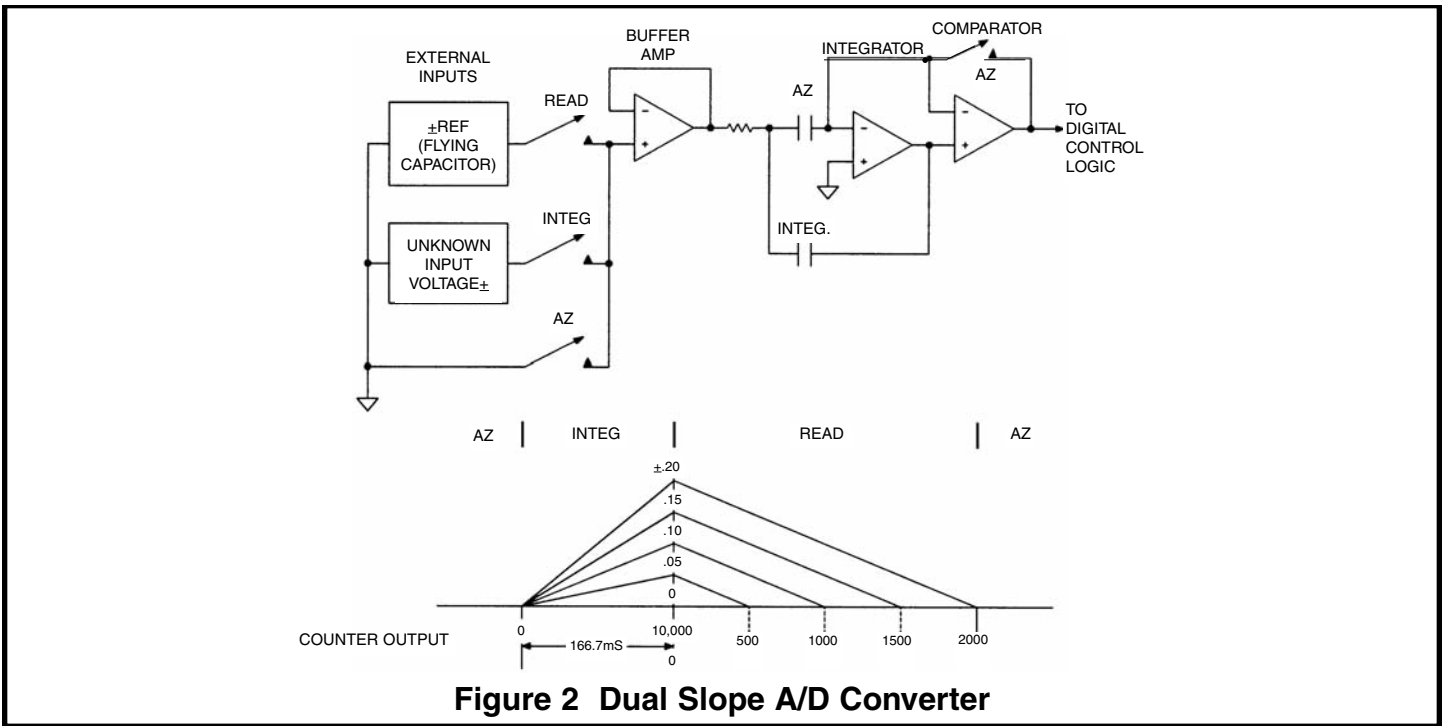
Digitized measurements data is presented to the display as four decoded digits (seven segments) plus polarity. Decimal point position on the display is determined by the selector switch setting.

## A/D CONVERTER

A simplified circuit diagram of the analog portion of the A/D converter is shown in Figure 2. Each of the switches shown represent analog gates which are operated by the digital section of the A/D converter. Basic timing for switch operation is keyed by an external oscillator. The conversion process is continuously repeated. A complete cycle is shown in Figure 2.

Any given measurement cycle performed by the A/D

converter can be divided into three consecutive time periods: autozero (AZ), integrate (INTEG) and read. Both autozero and integrate are fixed time periods. A counter determines the length of both time periods by providing an overflow at the end of every 1,000 clock pulses. The read period is a variable time, which is proportional to the unknown input voltage. The value of the voltage is determined by counting the number of clock pulses that occur during the read period.



**Figure 2 Dual Slope A/D Converter**

During autozero, a ground reference is applied as an input to the A/D converter. Under ideal conditions the output of the comparator would also go to zero. However, input-offset-voltage errors accumulate in the amplifier loop, and appear at the comparator output as an error voltage. This error is impressed across the AZ capacitor where it is stored for the remainder of the measurement cycle. The stored level is used to provide offset voltage correction during the integrate and read periods.

The integrate period begins at the end of the autozero period. As the period begins, the AZ switch opens and the INTEG switch closes. This applies the unknown input voltage to the input of the A/D converter. The voltage is buffered and passed on to the input of the A/D converter. The voltage is buffered and passed on to the integrator to determine the charge rate (slope) on the INTEG capacitor. At the end of the fixed integrate period, the capacitor is charged to a level proportional to the unknown input voltage. This voltage is translated to a digital indication by discharging the

capacitor at a fixed rate during the read period, and counting the number of clock pulses that occur before it returns to the original autozero level.

As the read period begins, the INTEG switch opens and the read switch closes. This applies a known reference voltage to the input of the A/D converter. The polarity of this voltage is automatically selected to be opposite that of unknown input voltage, thus causing the INTEG capacitor to discharge at a fixed rate (slope). When the charge is equal to the initial starting point (autozero level), the read period is ended. Since the discharge slope is fixed during the read period, the time required is proportional to the unknown input voltage.

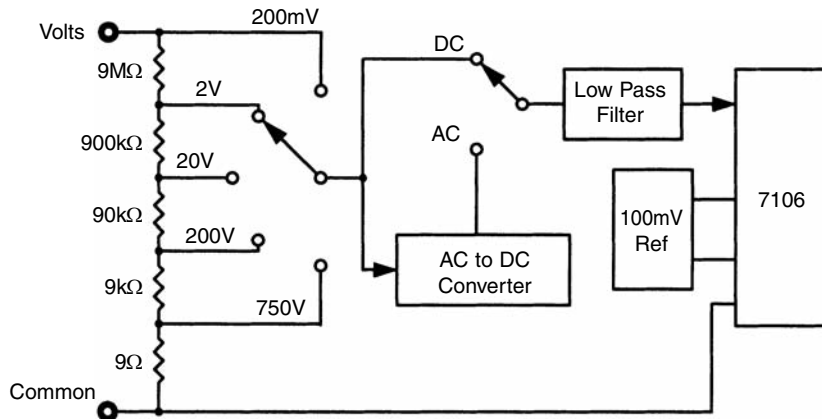
The autozero period and thus a new measurement cycle begins at the end of the read period. At the same time, the counter is released for operation by transferring its contents (previous measurement value) to a series of latches. This stored state is then decoded and buffered before being used for driving the LCD display.

## VOLTAGE MEASUREMENT

Figure 3 shows a simplified diagram of the voltage measurement function.

The input divider resistors add up  $10M\Omega$  with each step being a division of 10. The divider output should be within  $-0.199$  to  $+0.199V$  or the overload

indicator will function. If the AC function is selected, the divider output is AC coupled to a full wave rectifier and the DC output is calibrated to equal the rms level of the AC input.



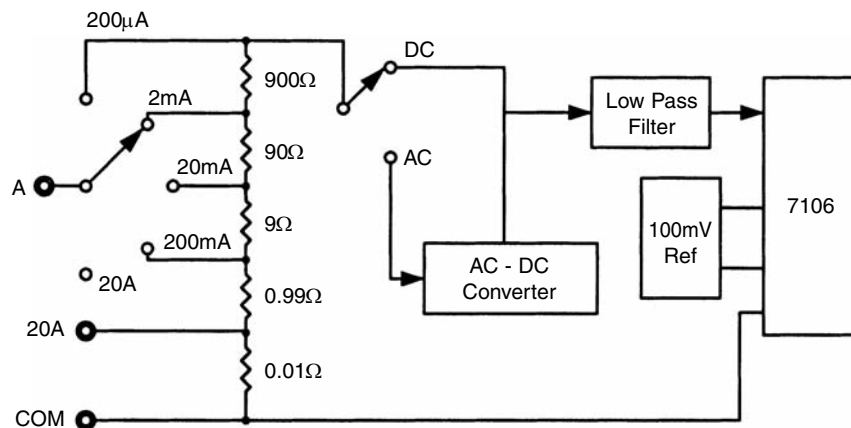
**Figure 3 Simplified Voltage Measurement Diagram**

## CURRENT MEASUREMENT

Figure 4 shows a simplified diagram of the current measurement positions.

Internal shunt resistors convert the current to between  $-0.199$  to  $+0.199V$  which is then

processed in the 7106 IC to light the appropriate LCD segments. If the current is AC in nature, the AC converter changes it to the equivalent DC value.



**Figure 4 Simplified Current Measurement Diagram**

## RESISTANCE MEASUREMENTS

Figure 5 shows a simplified diagram of the resistance measurement function.

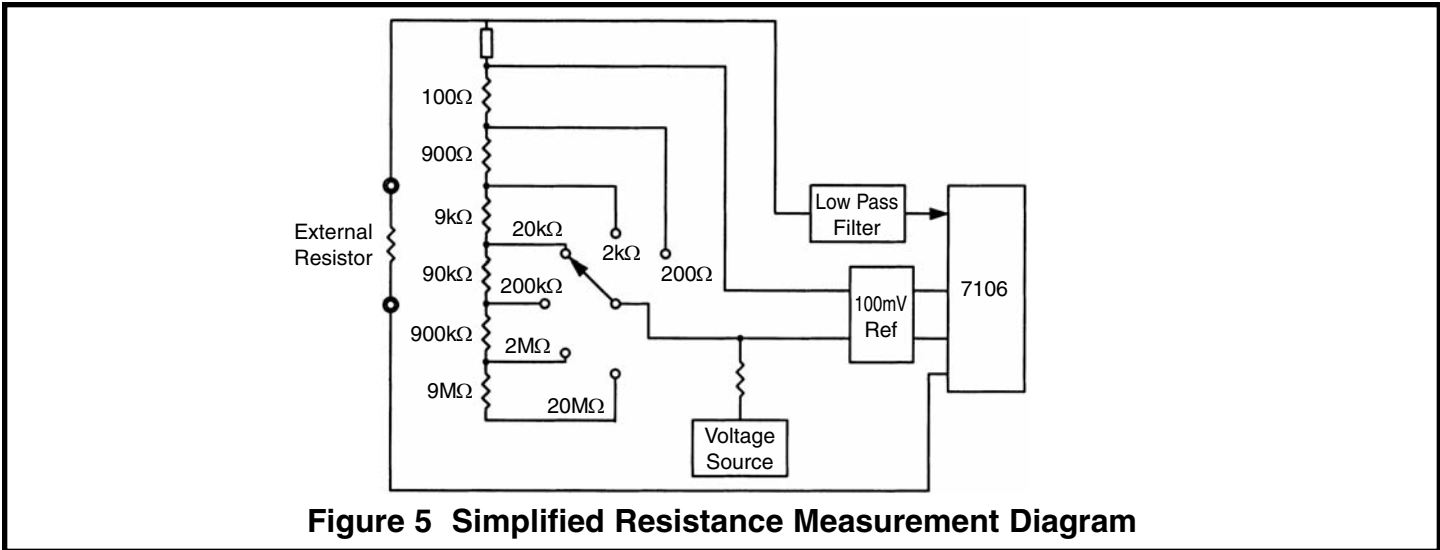


Figure 5 Simplified Resistance Measurement Diagram

A simple series circuit is formed by the voltage source, a reference resistor from the voltage divider (selected by range switches), and the external unknown resistor. The ratio of the two resistors is equal to the ratio of their respective voltage drops. Therefore, since the value of one resistor is known, the value of the second can be determined by using the voltage drop across the known resistor as a reference. This determination is made directly by the A/D converter.

Overall operation of the A/D converter during a resistance measurement is basically as described earlier in this section, with one exception. The reference voltage present during a voltage measurement is replaced by the voltage drop across the reference resistor. This allows the voltage across the unknown resistor to be read during the read period. As before, the length of the read period is a direct indication of the value of the unknown.

## h<sub>FE</sub> MEASUREMENT

Figure 6 shows a simplified diagram of the h<sub>FE</sub> measurement function. Internal circuits in the 7106 IC maintain the COMMON line at 2.8 volts below V<sub>+</sub>. When a PNP transistor is plugged into the transistor socket, base to emitter current flows through resistor R49. The voltage drop in resistor R49 due to the collector current is fed to the 7106 and indicates the h<sub>FE</sub> of the transistor. For an NPN transistor, the emitter current through R50 indicates the h<sub>FE</sub> of the transistor.

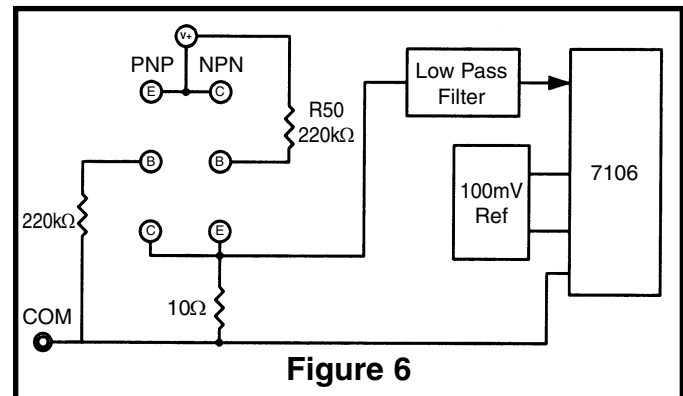


Figure 6

## CAPACITANCE MEASUREMENT

The capacitor circuit consists of four op-amps. IC3 D&A form an oscillator, which is applied to the test-capacitor through the test leads. The capacitor couples the oscillator to pin 6 of IC3B. The amount of voltage developed at pin 6 is indicative of the capacitor's ESR value. IC3B and C amplify the signal which is seen at pin 8. The AC signal is then converted to a DC voltage and displayed on the meter.

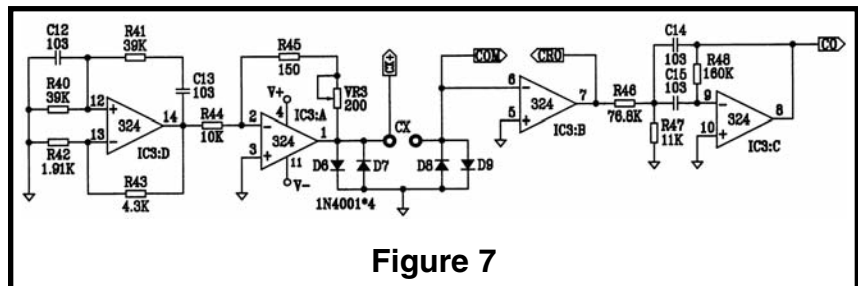
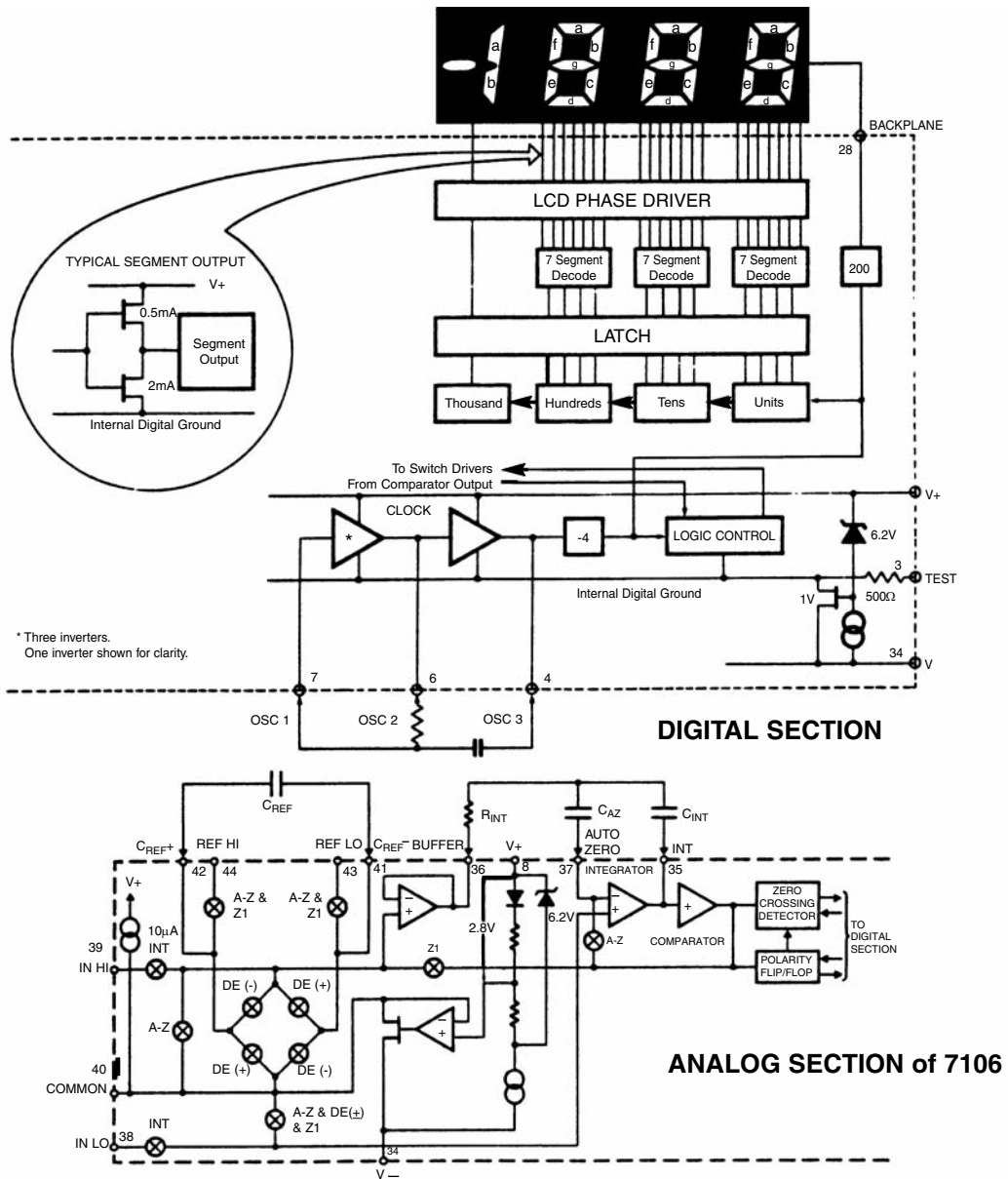
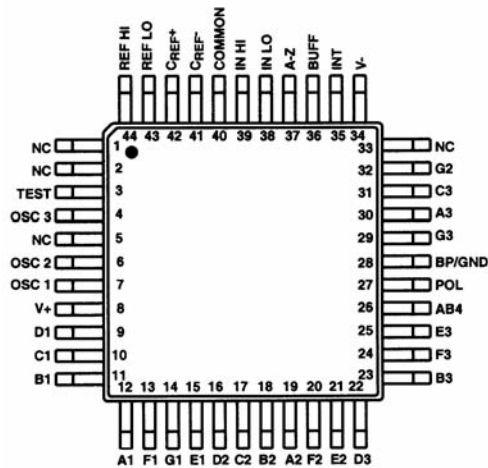


Figure 7



**Figure 8 7106 Functions**

**ICL7106, ICL7107 (MQFP)  
TOP VIEW**



---

## ASSEMBLY

The meter kit has been divided into a number of sections to make the assembly easy and avoid major problems with the meter operation.

**ONLY OPEN COMPONENT BAGS THAT ARE CALLED FOR IN YOUR ASSEMBLY PROCEDURE. DO NOT OPEN ANY OTHER BAGS.**

Do not build more than one section of your meter at a time. Your instructor must approve the proper operation of the section you have built before you proceed to the next section. This procedure will minimize the problems you may have at the completion of the project.

Your kit program is divided into Sections "A – F". The small parts bags will be marked accordingly. The sections are listed below.

Section A - Meter Display Circuit Assembly.

Section B - DC Voltage and Current Circuit Assembly.

Section C - AC Voltage and Current Circuit Assembly.

Section D - Resistance & Buzzer Circuit Assembly.

Section E - Capacitance and Transistor Circuit Assembly.

Section F - Final Assembly.

## IMPORTANT CONSTRUCTION NOTES

1. Wash your hands with soap and water before you assemble this kit. The high impedance areas on the circuit board can be contaminated by salt and oil from your skin. If these areas become contaminated, your completed multimeter may not meet the listed specifications. Handle the circuit board only by its edges.
2. Avoid any excessive accumulation of resin build-up whenever you solder a connection.
3. Take your time assembling the circuit board. Work at a slow pace. Remember that accuracy is far more important than speed.
4. When you perform the steps in assembly, identify each respective component before you install it. Then position it over its outline on the top legend side of the PCB, unless otherwise indicated.
5. Check for the proper polarity of ICs, diodes, electrolytic capacitors, battery snap and LCD.

# CONSTRUCTION

## Introduction

The most important factor in assembling your M-2666K Digital Multimeter Kit is good soldering techniques. Using the proper soldering iron is of prime importance. A small pencil type soldering iron of 25 - 40 watts is recommended. **The tip of the iron must be kept clean at all times and well-tinned.**

## Safety Procedures

- Wear eye protection when soldering and during all phases of construction.
- Locate soldering iron in an area where you do not have to go around it or reach over it.
- **Do not hold solder in your mouth.** Wash your hands thoroughly after handling solder.
- Be sure that there is adequate ventilation present.

## Assemble Components

In all of the following assembly steps, the components must be installed on the top side of the PC board unless otherwise indicated. The top legend shows where each component goes. The leads pass through the corresponding holes in the board and are soldered on the foil side.

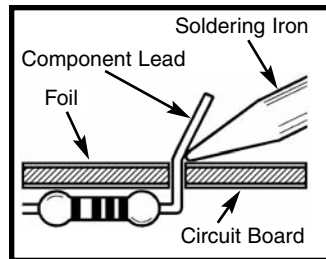
**Use only rosin core solder.**

**DO NOT USE ACID CORE SOLDER!**

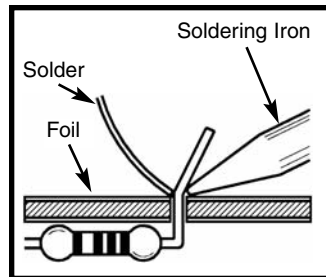
## What Good Soldering Looks Like

A good solder connection should be bright, shiny, smooth, and uniformly flowed over all surfaces.

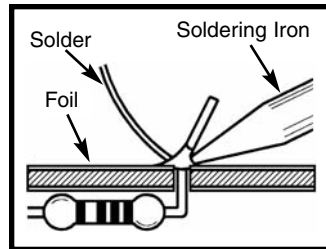
1. Solder all components from the copper foil side only. Push the soldering iron tip against both the lead and the circuit board foil.



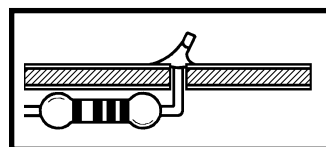
2. Apply a small amount of solder to the iron tip. This allows the heat to leave the iron and onto the foil. Immediately apply solder to the opposite side of the connection, away from the iron. Allow the heated component and the circuit foil to melt the solder.



3. Allow the solder to flow around the connection. Then, remove the solder and the iron and let the connection cool. The solder should have flowed smoothly and not lump around the wire lead.

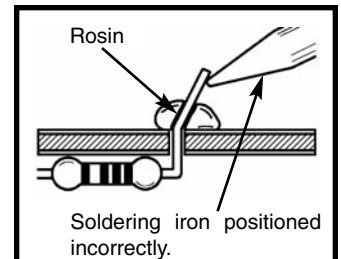


4. Here is what a good solder connection looks like.

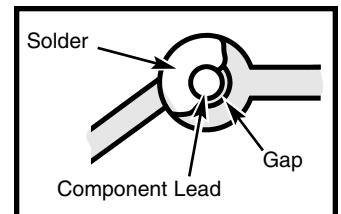


## Types of Poor Soldering Connections

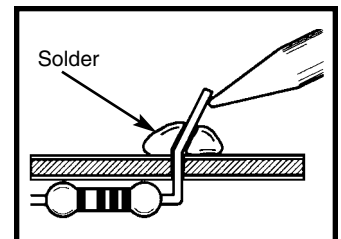
1. **Insufficient heat** - the solder will not flow onto the lead as shown.



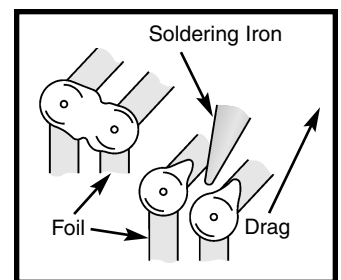
2. **Insufficient solder** - let the solder flow over the connection until it is covered. Use just enough solder to cover the connection.



3. **Excessive solder** - could make connections that you did not intend to between adjacent foil areas or terminals.



4. **Solder bridges** - occur when solder runs between circuit paths and creates a short circuit. This is usually caused by using too much solder. To correct this, simply drag your soldering iron across the solder bridge as shown.





## IDENTIFYING CAPACITOR VALUES

Capacitors will be identified by their capacitance value in pF (picofarads), nF (nanofarads), or  $\mu$ F (microfarads). Most capacitors will have their actual value printed on them. Some capacitors may have their value printed in the following manner. The maximum operating voltage may also be printed on the capacitor.

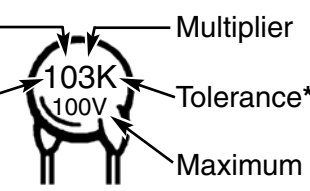
Second Digit →

Multiplier →


First Digit →

Tolerance\* →

Maximum Working Voltage →



| Multiplier | For the No. | 0           | 1 | 2  | 3   | 4  | 5   | 8    | 9   |
|------------|-------------|-------------|---|----|-----|----|-----|------|-----|
|            |             | Multiply By | 1 | 10 | 100 | 1k | 10k | 100k | .01 |



**Note:** The letter "R" may be used at times to signify a decimal point; as in 3R3 = 3.3

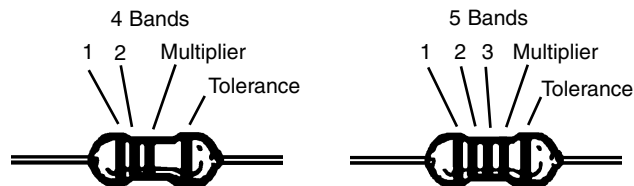
\* The letter M indicates a tolerance of  $\pm 20\%$   
 The letter K indicates a tolerance of  $\pm 10\%$   
 The letter J indicates a tolerance of  $\pm 5\%$

The value is  $10 \times 1,000 = 10,000\text{pF}$  or  $.01\mu\text{F}$  100V

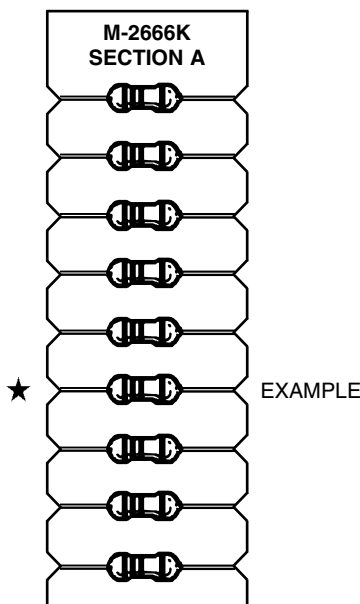
## IDENTIFYING RESISTOR VALUES

Use the following information as a guide in properly identifying the value of resistors.

| BAND 1<br>1st Digit |       | BAND 2<br>2nd Digit |       | BAND 3 (if used)<br>3rd Digit |       | Multiplier |            | Resistance Tolerance |              |
|---------------------|-------|---------------------|-------|-------------------------------|-------|------------|------------|----------------------|--------------|
| Color               | Digit | Color               | Digit | Color                         | Digit | Color      | Multiplier | Color                | Tolerance    |
| Black               | 0     | Black               | 0     | Black                         | 0     | Black      | 1          | Silver               | $\pm 10\%$   |
| Brown               | 1     | Brown               | 1     | Brown                         | 1     | Brown      | 10         | Gold                 | $\pm 5\%$    |
| Red                 | 2     | Red                 | 2     | Red                           | 2     | Red        | 100        | Brown                | $\pm 1\%$    |
| Orange              | 3     | Orange              | 3     | Orange                        | 3     | Orange     | 1,000      | Red                  | $\pm 2\%$    |
| Yellow              | 4     | Yellow              | 4     | Yellow                        | 4     | Yellow     | 10,000     | Orange               | $\pm 3\%$    |
| Green               | 5     | Green               | 5     | Green                         | 5     | Green      | 100,000    | Green                | $\pm 0.5\%$  |
| Blue                | 6     | Blue                | 6     | Blue                          | 6     | Blue       | 1,000,000  | Blue                 | $\pm 0.25\%$ |
| Violet              | 7     | Violet              | 7     | Violet                        | 7     | Silver     | 0.01       | Violet               | $\pm 0.1\%$  |
| Gray                | 8     | Gray                | 8     | Gray                          | 8     | Gold       | 0.1        |                      |              |
| White               | 9     | White               | 9     | White                         | 9     |            |            |                      |              |



## PART IDENTIFICATION CARDS



To help identify the resistors and diodes used in the construction of your digital multimeter we have mounted the diodes and resistors of each section onto a card. The card will help you find the diodes and resistors quickly. THE PARTS WILL NOT NECESSARILY BE LISTED IN THE ORDER SHOWN IN THE PARTS LIST SECTION OR IN THE ASSEMBLY PROCEDURE.

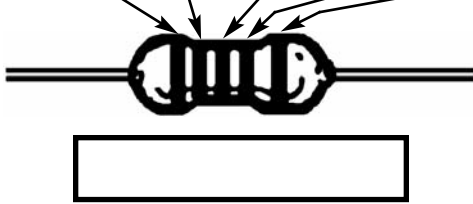
When you are ready to assemble the meter kit, follow the procedure shown. For an example refer to page 11 for assembly of Section "A". The first resistor called for is R8, 470k $\Omega$  resistor (yellow-violet-yellow-gold). Locate it on the card (★), verify that it is the correct value. Some resistors may be mounted backwards on the card so you must be certain that you are reading the resistors correctly. When the correct value has been established, only then will you mount it into its correct position on the PC board.

# RESISTOR READING EXERCISE

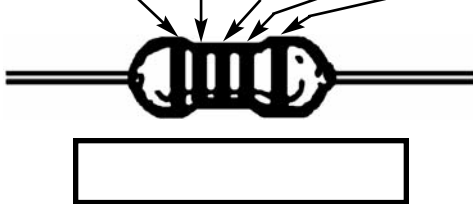
Before starting assembly of your digital multimeter project, you should be thoroughly familiar with the 5 band color code system. Many of the resistor values will be identified by color bands and it is easy to mistake their value if you read the colors incorrectly

or read the value from the wrong end. Do the following exercise in resistor values. Place your answer in the box beneath the resistor. Answers are on the bottom of this page.

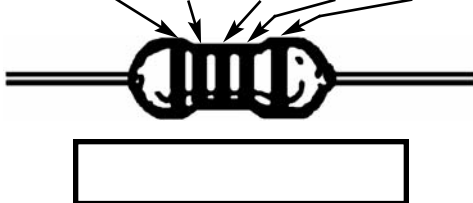
(1) yellow-black-black-black-brown



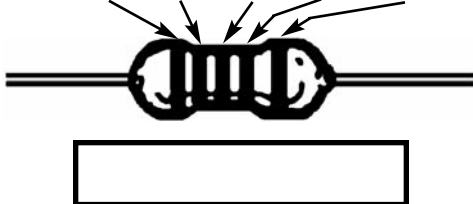
(3) brown-red-violet-red-brown



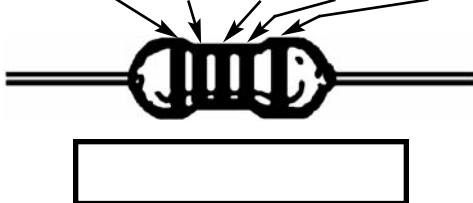
(5) brown-black-black-black-brown



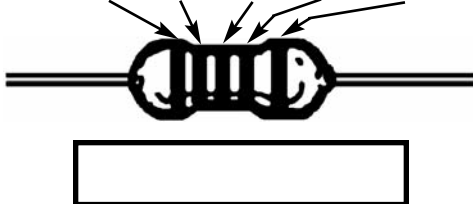
(7) white-black-black-yellow-green



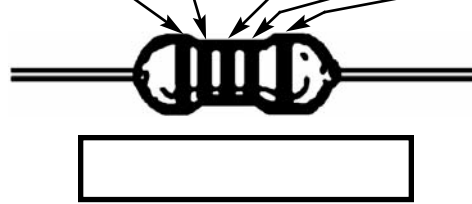
(9) brown-black-black-orange-green



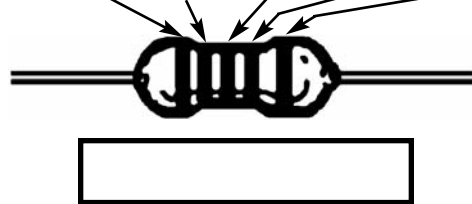
(11) gray-white-black-black-brown



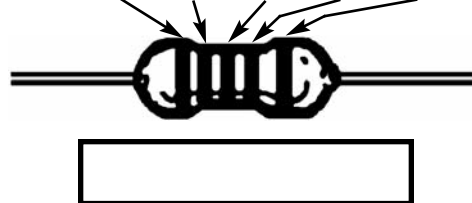
(2) white-black-black-red-green



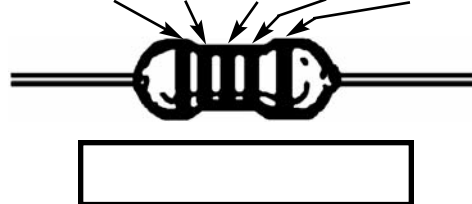
(4) green-black-green-brown-green



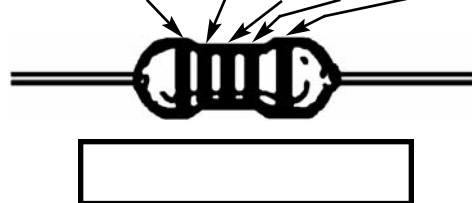
(6) brown-green-gray-orange-brown



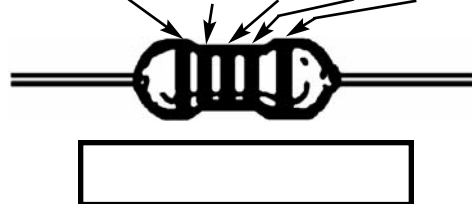
(8) white-black-black-silver-green



(10) orange-white-red-red-brown



(12) brown-brown-black-red-brown



Answers to Resistor Reading Exercise: (1) 400k $\pm$ 1%; (2) 90k $\pm$ .5%; (3) 12.7k $\pm$ 1%; (4) 5.05k $\pm$ .5%; (5) 100k $\pm$ 1%; (6) 158k $\pm$ 1%; (7) 9M $\Omega$  $\pm$ .5%; (8) 9k $\pm$ .5%; (9) 100k $\pm$ .5%; (10) 39.2k $\Omega$  $\pm$ 1%; (11) 890 $\Omega$  $\pm$ 1%; (12) 11k $\Omega$  $\pm$ 1%;

# SECTION A

## Meter Display Circuit

### PARTS LIST - SECTION A

If you are a student, and any parts are missing or damaged, please see instructor or bookstore.  
 If you purchased this kit from a distributor, catalog, etc., please contact Elenco® Electronics (address/phone/e-mail is at the back of this manual) for additional assistance, if needed. **DO NOT** contact your place of purchase as they will not be able to help you.

#### RESISTORS

| Qty.                       | Symbol     | Description   | Color Code                | Part # |
|----------------------------|------------|---------------|---------------------------|--------|
| <input type="checkbox"/> 2 | R4, R5     | 100kΩ 5% 1/4W | brown-black-yellow-gold   | 161000 |
| <input type="checkbox"/> 1 | R3         | 200kΩ 5% 1/4W | red-black-yellow-gold     | 162000 |
| <input type="checkbox"/> 1 | R1         | 220kΩ 5% 1/4W | red-red-yellow-gold       | 162200 |
| <input type="checkbox"/> 3 | R7, R8, R9 | 470kΩ 5% 1/4W | yellow-violet-yellow-gold | 164700 |
| <input type="checkbox"/> 2 | R2, R6     | 1MΩ 5% 1/4W   | brown-black-green-gold    | 171000 |

#### CAPACITORS

| Qty.                       | Symbol     | Value       | Description          | Part #  |
|----------------------------|------------|-------------|----------------------|---------|
| <input type="checkbox"/> 1 | C5         | 100pF (101) | Disc                 | 221017  |
| <input type="checkbox"/> 1 | C1         | .1μF (104)  | Mylar (large brown)  | 251017L |
| <input type="checkbox"/> 3 | C2, C3, C4 | .1μF (104)  | Mylar (small yellow) | 251017S |
| <input type="checkbox"/> 1 | C6         | 22μF        | Electrolytic (Lytic) | 272244S |

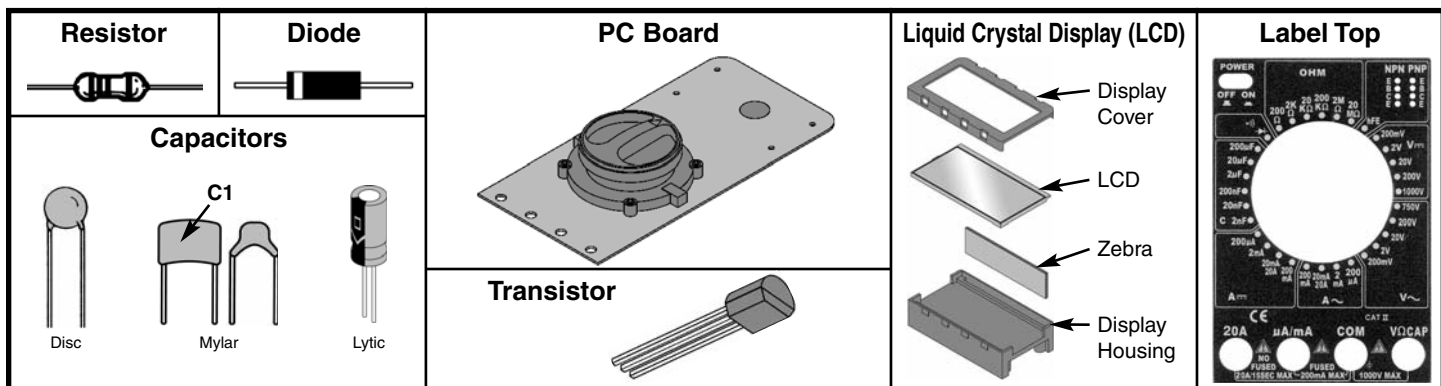
#### SEMICONDUCTORS

| Qty.                       | Symbol | Value | Description        | Part # |
|----------------------------|--------|-------|--------------------|--------|
| <input type="checkbox"/> 1 | T1     | 9013  | Transistor 2SC9013 | 329013 |

#### MISCELLANEOUS

| Qty.                       | Description         | Part # | Qty.                       | Description         | Part # |
|----------------------------|---------------------|--------|----------------------------|---------------------|--------|
| <input type="checkbox"/> 1 | LCD                 | 351166 | <input type="checkbox"/> 1 | Battery Snap (Batt) | 590098 |
| <input type="checkbox"/> 1 | Zebra               | 500007 | <input type="checkbox"/> 1 | LCD Housing         | 629015 |
| <input type="checkbox"/> 1 | PC Board M2666K     | 512666 | <input type="checkbox"/> 1 | LCD Cover           | 629016 |
| <input type="checkbox"/> 1 | Switch On/Off (SW1) | 540004 | <input type="checkbox"/> 1 | Label Top           | 723051 |
| <input type="checkbox"/> 1 | Battery 9V          | 590009 | <input type="checkbox"/> 2 | Solder              | 9LF99  |

### PARTS IDENTIFICATION



# ASSEMBLE THE FOLLOWING COMPONENTS TO THE PC BOARD

In all of the following steps the components must be installed either on the top or bottom legend sides of the PC board as indicated. The board is turned to solder the component leads on the opposite side (installed on Bottom, soldered on Top, installed on Top, soldered on Bottom).

**Figure A**

White marking on PC board

Stand resistor on end as shown. Solder and cut off the excess leads.

**Figure B**

Negative (-) marking on capacitor

Negative (-) marking on PC board

Mount the capacitor with the negative (-) lead in the negative hole and the positive (+) lead in the positive hole marked on the PC board. Mount the capacitor flat against the PC board as shown.

**Figure C**

Flat Side

Marking on PC board

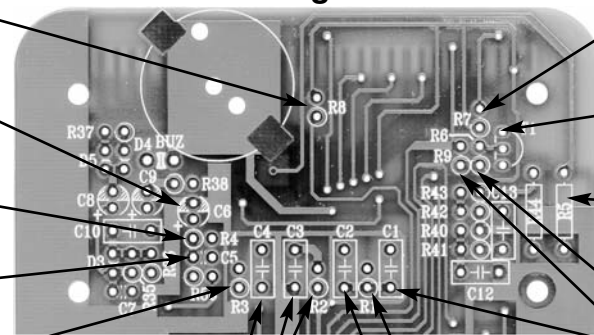
Mount the transistor with the flat side in the same direction as the PC board marking.

**Figure D**

Lay resistor flat against the PC board.

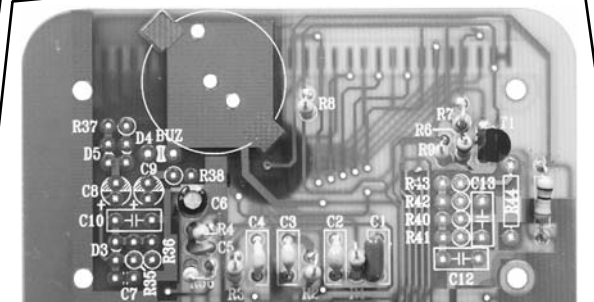
- R8 - 470kΩ 5% 1/4W Res. (yellow-violet-yellow-gold) (see Figure A)
- C6 - 22μF Lytic Capacitor (see Figure B)
- R4 - 100kΩ 5% 1/4W Res. (brown-black-yellow-gold) (see Figure A)
- C5 - 100pF (101) Discap
- R3 - 200kΩ 5% 1/4W Res. (red-black-yellow-gold) (see Figure A)
- C4 - .1μF (104) Mylar Cap. (small yellow)
- C3 - .1μF (104) Mylar Cap. (small yellow)
- R2 - 1MΩ 5% 1/4W Res. (brown-black-green-gold) (see Figure A)

## Bottom Legend Side



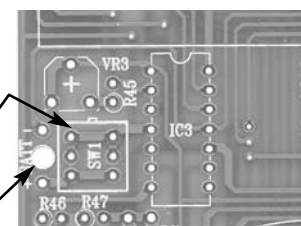
- R7 - 470kΩ 5% 1/4W Res. (yellow-violet-yellow-gold) (see Figure A)
- T1 - 2SC9013 Transistor (see Figure C)
- R5 - 100kΩ 5% 1/4W Res. (brown-black-yellow-gold) (see Figure D)
- R6 - 1MΩ 5% 1/4W Res. (brown-black-green-gold) (see Figure A)
- R9 - 470kΩ 5% 1/4W Res. (yellow-violet-yellow-gold) (see Figure A)
- C1 - .1μF (104) Mylar Cap. (large brown)
- R1 - 220kΩ 5% 1/4W Res. (red-red-yellow-gold) (see Figure A)
- C2 - .1μF (104) Mylar Cap. (small yellow)

## Assembled View



Mount switch in direction shown.

- SW1 - Switch On/Off (see Figure E)
- BATT - 9V Battery Snap (see Figure E)

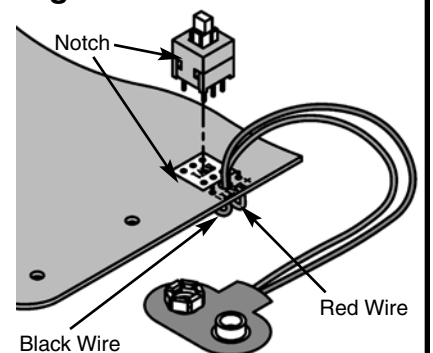


## Top Legend Side

## Figure E

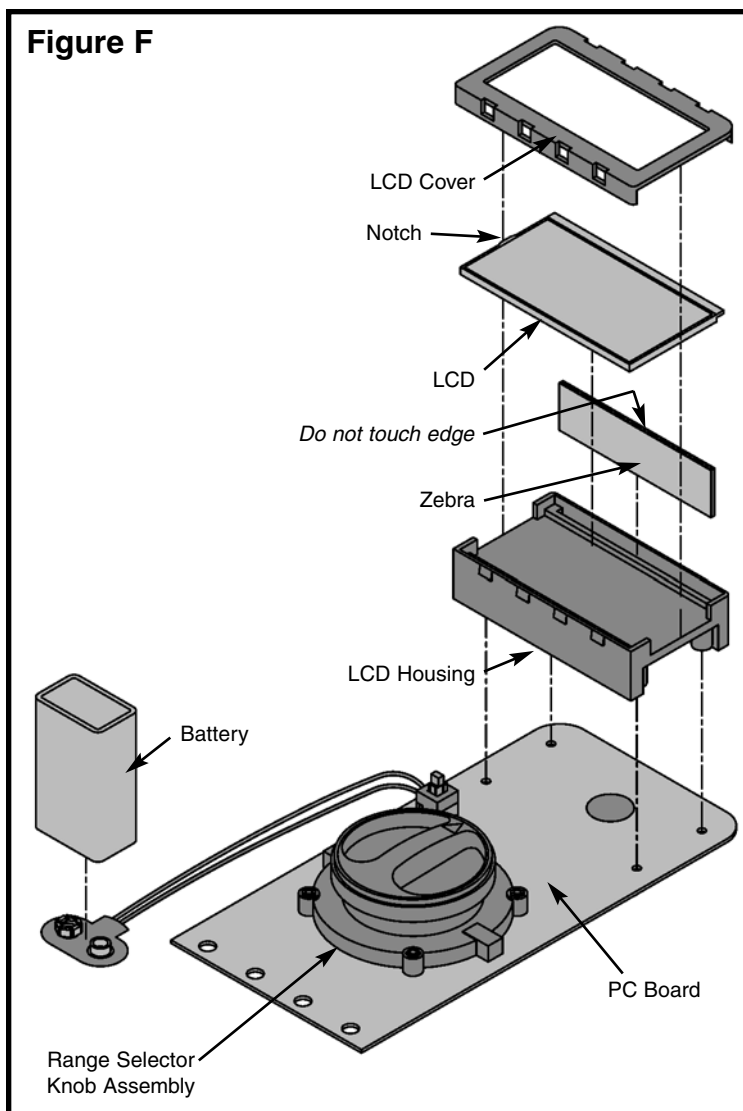
Insert the switch into the PC board in the location shown. Make sure that the notch on the switch is in the same direction as the marking on the PC board.

Insert the 9V battery wires through the hole of the PC board as shown. Solder and cut off the excess leads.



## ASSEMBLE THE LCD

- ❑ Assemble the LCD into the housing with the parts shown in Figure F. Note the top of the house is curved.
- ❑ Wipe off zebra edges with a lint-free cloth and then insert the zebra into the top slot of the housing.
- ❑ The LCD must be put in with the notch in the direction shown in Figure F. Peel off the clear protective film on top of the LCD (see Figure F), then place the LCD into the housing.
- ❑ Place the display cover on top of the housing and press down to snap into place.
- ❑ Place the LCD housing on top of the PC board as shown.

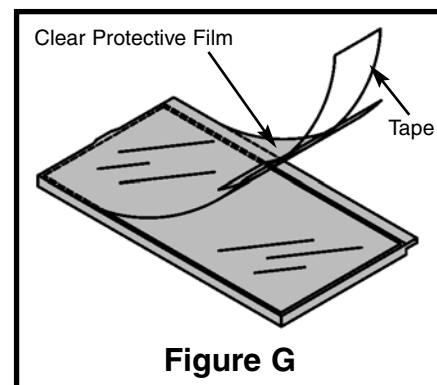


## Testing Procedure

The LCD housing will not be screwed to the PC board for this test. Align the LCD housing holes with those in the PC Board and hold in place. You can also use a rubber band to hold the housing. You will need to apply pressure so the zebra makes contact to the copper pads.

1. Place the top label over the knob. This will assist in obtaining the correct knob position.
2. Connect the 9V battery to the battery snap
3. Turn the meter on by pressing the power switch (down position).
4. Align the LCD housing holes with those in the PC Board and hold in place. You can also use a rubber band to hold the housing. You will need to apply pressure so the zebra makes contact to the copper pads.
5. Set the selector switch to the  $200\Omega$  position. The first decimal point should light and show a 200 under it. Select the  $20k\Omega$  position and the second decimal points lights with a 20 under it. Select the  $2k\Omega$  position and the second decimal points lights with a 2 under it. Adjust the selector to other ranges and check that correct decimal point lights. The LCD may display random numbers.

If the tests are not working, check for cold solder joints, part values and if the LCD is assembled correctly. **DO NOT PROCEED TO SECTION B WITHOUT INSTRUCTOR'S APPROVAL.**



# SECTION B

## DC Voltage & Current Circuit

### PARTS LIST - SECTION B

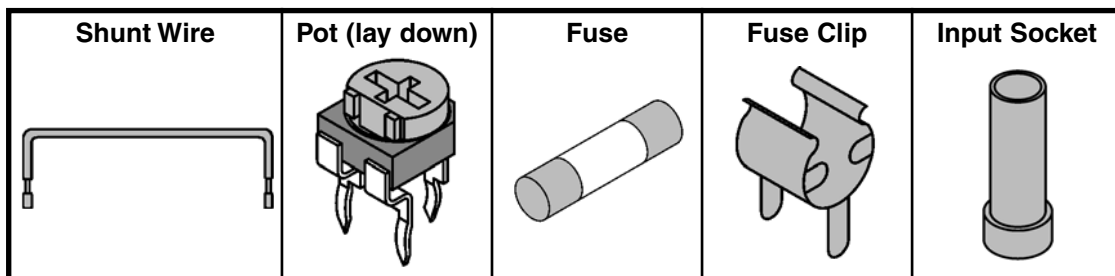
| RESISTORS |          |                  |                                |        |
|-----------|----------|------------------|--------------------------------|--------|
| Qty.      | Symbol   | Description      | Color Code                     | Part # |
| ☐ 1       | R23      | .01Ω             | Shunt wire                     | 100166 |
| ☐ 1       | R22      | 0.99Ω 0.5% 1/4W  | black-white-white-silver-green | 109950 |
| ☐ 1       | R21      | 9Ω 0.5% 1/4W     | white-black-black-silver-green | 119050 |
| ☐ 1       | R20      | 90Ω 0.5% 1/4W    | white-black-black-gold-green   | 129050 |
| ☐ 1       | R18      | 100Ω 0.5% 1/4W   | brown-black-black-black-green  | 131050 |
| ☐ 1       | R32      | 390Ω 1% 1/4W     | orange-white-black-black-brown | 133930 |
| ☐ 1       | R31      | 900Ω 1% 1/4W     | white-black-black-black-brown  | 139030 |
| ☐ 2       | R17, R19 | 900Ω 0.5% 1/4W   | white-black-black-black-green  | 139050 |
| ☐ 1       | R33      | 5.6kΩ 5% 1/4W    | green-blue-red-gold            | 145600 |
| ☐ 1       | R16      | 9kΩ 0.5% 1/4W    | white-black-black-brown-green  | 149050 |
| ☐ 1       | R30      | 13kΩ 1% 1/4W     | brown-orange-black-red-brown   | 151330 |
| ☐ 1       | R15      | 90kΩ 0.5% 1/4W   | white-black-black-red-green    | 159050 |
| ☐ 1       | R14      | 900kΩ 0.5% 1/4W  | white-black-black-orange-green | 169050 |
| ☐ 4       | R10-R13  | 2.25MΩ 0.5% 1/4W | red-red-green-yellow-green     | 172250 |
| ☐ 1       | VR1      | 200Ω (201)       | Pot (lay down)                 | 191320 |

**Note:** Resistor tolerance (last band) of 5-band resistors may be blue instead of green.

| SEMICONDUCTORS |        |         |             |        |
|----------------|--------|---------|-------------|--------|
| Qty.           | Symbol | Value   | Description | Part # |
| ☐ 2            | D1, D2 | 1N4001  | Diode       | 314001 |
| ☐ 1            | T2     | 2SA9013 | Transistor  | 329013 |

| MISCELLANEOUS |        |                                       |        |  |
|---------------|--------|---------------------------------------|--------|--|
| Qty.          | Symbol | Description                           | Part # |  |
| ☐ 1           |        | Fuse 0.2A 250V 5 x 20mm               | 530020 |  |
| ☐ 2           |        | Screw 2.5 x 8mm                       | 642239 |  |
| ☐ 2           |        | Fuse Clips                            | 663004 |  |
| ☐ 4           |        | Input Socket (20A, μA/mA, COM, VΩCAP) | 664066 |  |

### PARTS IDENTIFICATION

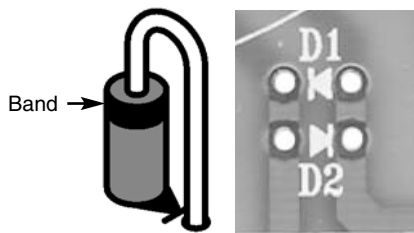


# ASSEMBLE THE FOLLOWING COMPONENTS TO THE PC BOARD

In all of the following steps the components must be installed either on the top or bottom legend sides of the PC board as indicated. The board is turned to solder the component leads on the opposite side (installed on Bottom, soldered on Top, installed on Top, soldered on Bottom).

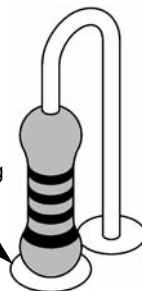
**Figure H**

Stand diode on end. Mount with band as shown on the top legend.



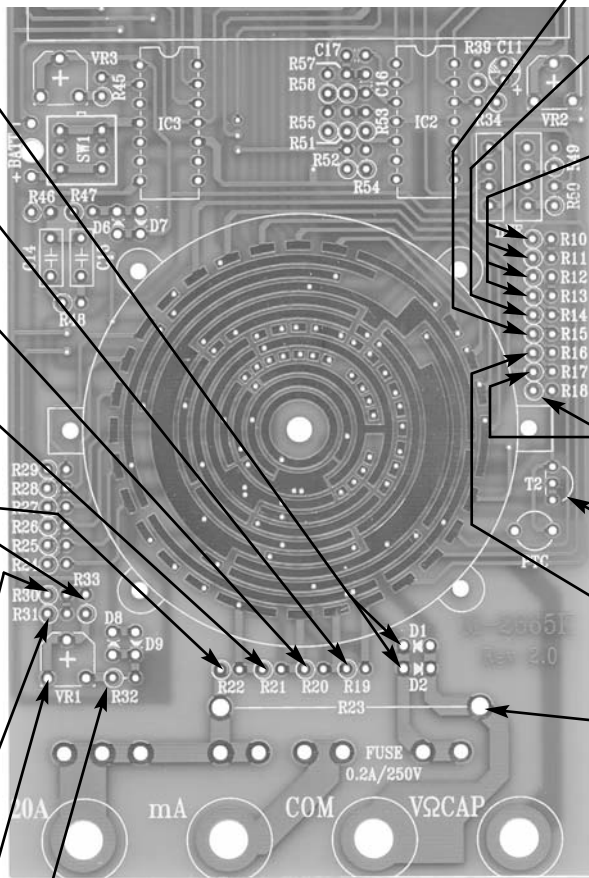
**Figure I**

White marking on PC board



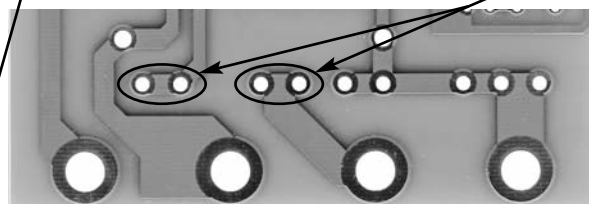
Stand resistor on end as shown. Solder and cut off the excess leads.

- D1 - 1N4001 Diode
- D2 - 1N4001 Diode (see Figure H)
- R19 - 900Ω .5% 1/4W Res. (white-blk-blk-blk-green) (see Figure I)
- R20 - 90Ω .5% 1/4W Res. (white-blk-blk-gold-green) (see Figure I)
- R21 - 9Ω .5% 1/4W Res. (white-blk-blk-silver-green) (see Figure I)
- R22 - 0.99Ω .5% 1/4W Res. (blk-wht-wht-silver-green) (see Figure I)
- R33 - 5.6kΩ 5% 1/4W Res. (green-blue-red-gold) (see Figure I)
- R30 - 13kΩ 1% 1/4W Res. (brn-orange-blk-red-brn) (see Figure I)
- R31 - 900Ω 1% 1/4W Res. (white-blk-blk-blk-brown) (see Figure I)
- VR1 - 200Ω Pot (201)
- R32 - 390Ω 1% 1/4W Res. (orange-wht-blk-blk-brown) (see Figure I)



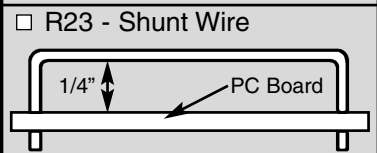
**Top Legend Side**

See Page 21 for Assembled View

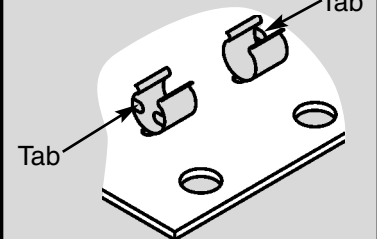


**Bottom Legend Side**

- R15 - 90kΩ .5% 1/4W Res. (white-blk-blk-red-green) (see Figure I)
- R14 - 900kΩ .5% 1/4W Res. (white-blk-blk-orange-green) (see Figure I)
- R10 - 2.25MΩ .5% 1/4W Res.
- R11 - 2.25MΩ .5% 1/4W Res.
- R12 - 2.25MΩ .5% 1/4W Res.
- R13 - 2.25MΩ .5% 1/4W Res. (red-red-green-yellow-green) (see Figure I)
- R18 - 100Ω .5% 1/4W Res. (brown-blk-blk-blk-green) (see Figure I)
- R17 - 900Ω .5% 1/4W Res. (white-blk-blk-blk-green) (see Figure I)
- T2 - 9013 Transistor (see Figure C)
- R16 - 9kΩ .5% 1/4W Res. (white-blk-blk-brown-green) (see Figure I)
- R23 - Shunt Wire

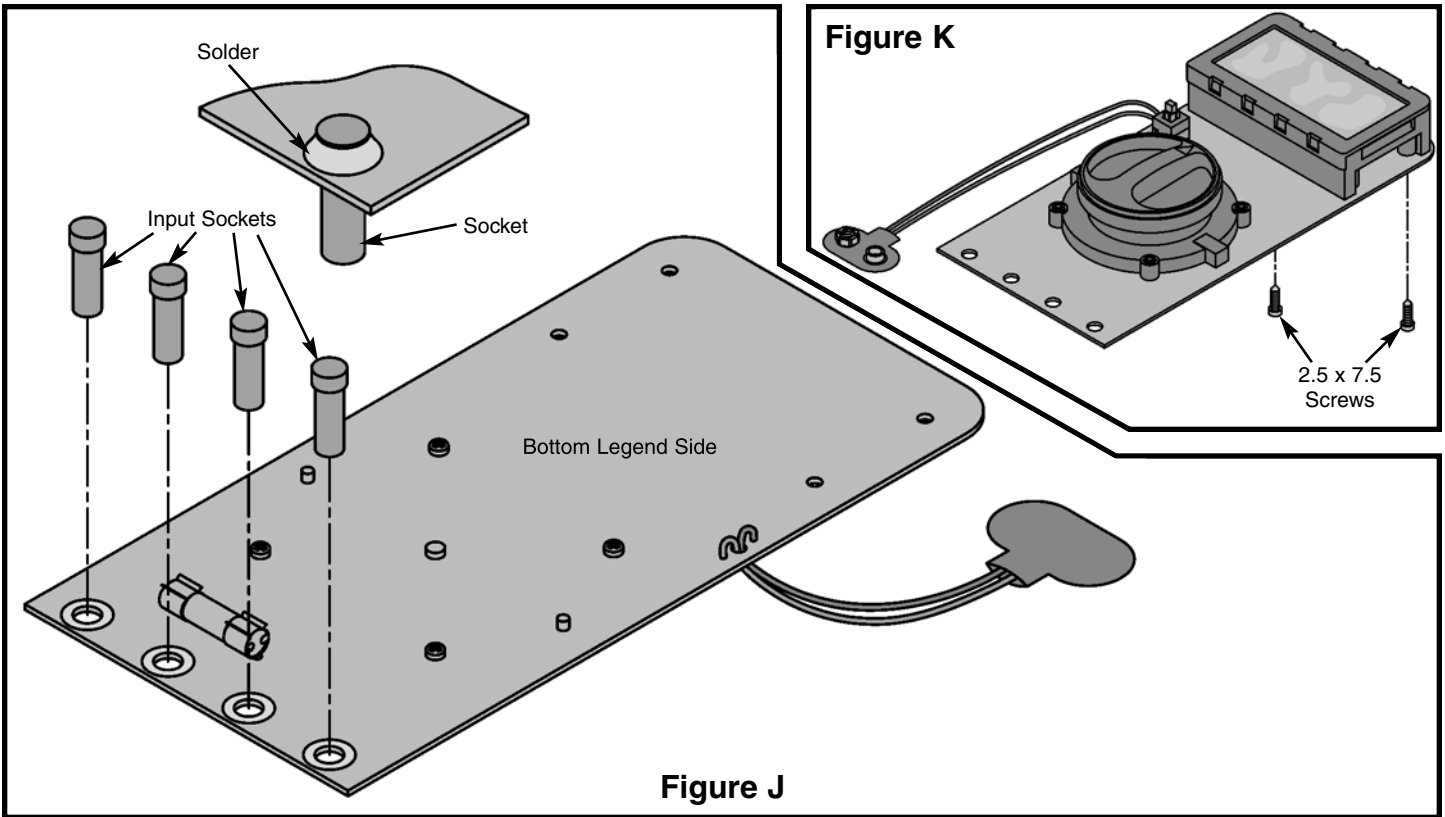


- Fuse Holder Clips
  - Fuse 0.2A 250V
- Mount holders with the tab side as shown on the bottom legend side, solder into place and then insert fuse.



- ❑ Insert the four input sockets into the PC board holes and then solder the sockets in place. Apply enough heat to allow the solder to flow around the input sockets (see Figure J).

- ❑ Attach the LCD to the PC board using the two 2.5 x 8mm screws. Use the two top mounting hole and lightly tighten the screws. The screws will be removed to assemble the next section.



## Testing Procedure

### Voltage Test

1. Place the top label over the knob and turn the range selector knob to the 20V position.
2. Connect the 9V battery to the battery snap
3. Connect the test leads (red lead to  $V\Omega CAP$  and black to COM). Turn the meter on by pressing the power switch.
4. Using another meter of known accuracy, measure a DC voltage less than 20V (such as a 9 volt battery). You will calibrate the kit meter by measuring the same voltage source and adjusting VR1 until the kit meter reads the same as the accurate meter. When the two meters agree, the voltage circuit is calibrated. Turn the meter off and continue to the Current Test.

If the tests are not working, check components R10 – R24, R30 – R33, VR1, and the transistor T2.

### Current Test

1. Turn the range selector knob to the 200 $\mu A$  position.
2. Connect the test leads (red lead to  $\mu A/mA$  and black to COM).
3. Connect the kit meter and another meter of known accuracy in series. Set the both meters in the 200 $\mu A$  position. Construct a circuit for a DC current (for example 9V and a 47k $\Omega$  resistor for 190 $\mu A$ ) and measure the circuit. Both meters should have close to the same readings. Check the other DC current (2mA - 200mA) scales. The 20A scale requires a circuit of 1 - 20 amps.

If the meters do not agree, check the parts just added. Do not readjust VR1 for this will change the voltage reading set in step 1. If the tests are not working, check for cold solder joints and part values.

4. Turn the meter off and remove the battery, top label, and test leads **DO NOT PROCEED TO SECTION C WITHOUT YOUR INSTRUCTOR'S APPROVAL.**
5. Remove two display mounting screws and display by unscrewing the two mounting screws.



# SECTION C

## AC Voltage & Current Circuit

### PARTS LIST - SECTION C

#### RESISTORS

| Qty.                       | Symbol   | Description            | Color Code                     | Part # |
|----------------------------|----------|------------------------|--------------------------------|--------|
| <input type="checkbox"/> 1 | R38      | 1.87k $\Omega$ 1% 1/4W | brown-gray-violet-brown-brown  | 141830 |
| <input type="checkbox"/> 1 | R37      | 3k $\Omega$ 1% 1/4W    | orange-black-black-brown-brown | 143030 |
| <input type="checkbox"/> 1 | R39      | 6.8k $\Omega$ 5% 1/4W  | blue-gray-red-gold             | 146800 |
| <input type="checkbox"/> 1 | R34      | 100k $\Omega$ 5% 1/4W  | brown-black-yellow-brown       | 161000 |
| <input type="checkbox"/> 2 | R35, R36 | 100k $\Omega$ 1% 1/4W  | brown-black-black-orange-brown | 161030 |
| <input type="checkbox"/> 1 | VR2      | 200 $\Omega$           | Trim Pot                       | 191320 |

**Note:** Resistor tolerance (last band) of 5-band resistors may be blue instead of green.

#### CAPACITORS

| Qty.                       | Symbol | Value             | Description          | Part #  |
|----------------------------|--------|-------------------|----------------------|---------|
| <input type="checkbox"/> 1 | C7     | 470pF (471)       | Disc                 | 224717  |
| <input type="checkbox"/> 1 | C10    | .33 $\mu$ F (334) | Mylar (small yellow) | 253318L |
| <input type="checkbox"/> 2 | C8, C9 | 4.7 $\mu$ F       | Electrolytic (Lytic) | 264747S |
| <input type="checkbox"/> 1 | C11    | 10 $\mu$ F        | Electrolytic (Lytic) | 271015S |

#### SEMICONDUCTORS

| Qty.                       | Symbol  | Value  | Description   | Part # |
|----------------------------|---------|--------|---------------|--------|
| <input type="checkbox"/> 3 | D3 - D5 | 1N4148 | Diode (glass) | 314148 |
| <input type="checkbox"/> 1 | IC2     | LM324  | Op-Amp        | 330324 |

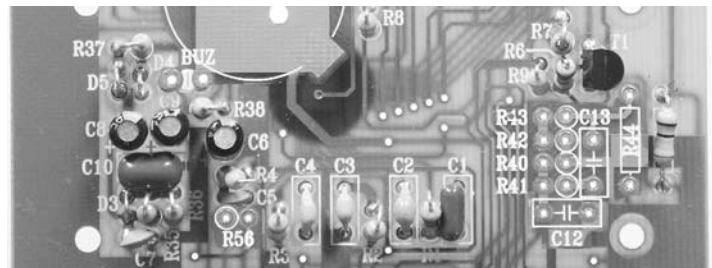
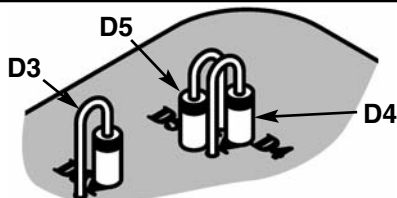
#### MISCELLANEOUS

| Qty.                       | Symbol | Value | Description      | Part # |
|----------------------------|--------|-------|------------------|--------|
| <input type="checkbox"/> 1 |        |       | IC Socket 14-pin | 664014 |

### ASSEMBLE THE FOLLOWING COMPONENTS TO THE PC BOARD

**Figure L**

Stand diode on end. Mount with band as shown on the top legend.



**Assembled View**

R37 - 3k $\Omega$  1% 1/4W Res.  
(orange-blk-blk-brn-brn)  
(see Figure I)

D4 - 1N4148 Diode

D5 - 1N4148 Diode  
(see Figure L)

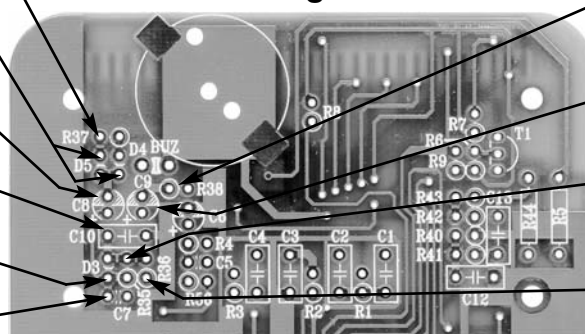
C8 - 4.7 $\mu$ F Lytic Capacitor  
(see Figure B)

C10 - .33 $\mu$ F (334) Mylar Cap.  
(may be marked 334)

D3 - 1N4148 Diode  
(see Figure L)

C7 - 470pF (471) Discap

**Bottom Legend Side**



R38 - 1.87k $\Omega$  1% 1/4W Res.  
(brn-gray-violet-brn-brn)  
(see Figure I)

C9 - 4.7 $\mu$ F Lytic Capacitor  
(see Figure B)

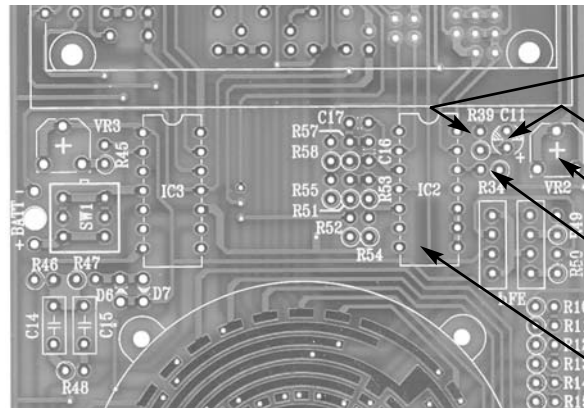
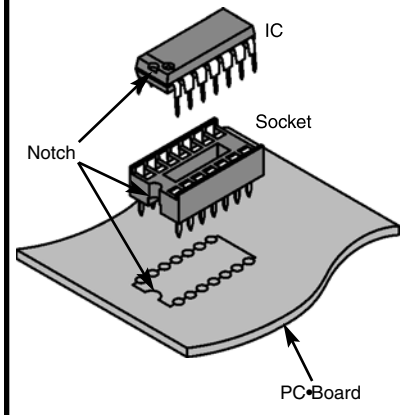
R35 - 100k $\Omega$  1% 1/4W Res.  
(brown-blk-blk-orange-brown)  
(see Figure I)

R36 - 100k $\Omega$  1% 1/4W Res.  
(brown-blk-blk-orange-brown)  
(see Figure I)

## ASSEMBLE THE FOLLOWING COMPONENTS TO THE PC BOARD

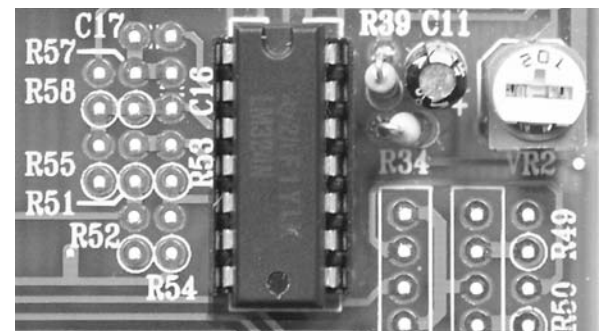
**Figure M**

Insert the IC socket into the PC board with the notch in the same direction marked on the top legend. Solder the IC socket into place. Insert the IC into the socket with the notch in the same direction as the notch on the socket.



**Top Legend Side**

- R39 - 6.8k $\Omega$  5% 1/4W Res. (blue-gray-red-gold) (see Figure I)
- C11 - 10 $\mu$ F Lytic Capacitor (see Figure B)
- VR2 - 200 $\Omega$  Pot (201)
- R34 - 100k $\Omega$  5% 1/4W Res. (brown-black-yellow-brown) (see Figure I)
- IC Socket 14-pin
- IC2 - LM324 Op-Amp IC (see Figure M)



**Assembled View**

- Attach the LCD to the PC board using the two 2.5 x 8mm screws. Use the top-mounting hole and lightly tighten the screws. The screws will be removed to assemble the next section.

### AC Voltage Test

Caution do not handle the PC board during the Voltage or Current test. If you do an AC source, set VR2 to its middle position.

1. Placing the top label over the knob will assist in obtaining the correct knob position when doing tests.
2. Connect the 9V battery to the battery snap.
3. Connect the test leads (red lead to V $\Omega$  and black to COM). Turn the meter on by pressing the power switch.
4. Obtain an AC voltage and set the meter to the appropriate range.
5. Using another meter of known accuracy, measure the AC voltage. You will calibrate the kit meter by measuring the same voltage source and adjusting VR2 until the kit meter reads the same as the accurate meter. When the two meters agree, the AC voltage circuit is calibrated. Turn the meter off and continue to the Current Test.

If the tests are not working, check components R34 – R39, VR2, C7-C11, and IC2.

### AC Current Test

1. Turn the range selector knob to the 200mA AC current position.
2. Connect the test leads (red lead to  $\mu$ A/mA and black to COM) to the meter.
3. Connect the kit meter and another meter of known accuracy in series. Set the meters to the 200mA position. Construct a circuit for an AC current (for example 12VAC and a 100 $\Omega$  resistor for 120mA) and connect the meters to the circuit.
4. Turn the meters on and both should have close to the same readings. Check the other current scale by changing the voltage or resistance values. The 20A scale requires a circuit of 1-20 amps. For the 20A shunt wire adjustment, refer to page 32.

If the kit meter does not agree, check the parts just added. Do not readjust VR2 for this will change the AC voltage read. If the tests are not working, check for cold solder joints and part values. Turn the meter off and remove the battery and test leads. **DO NOT PROCEED TO SECTION D WITHOUT YOUR INSTRUCTOR'S APPROVAL.**

Remove the two display mounting screws and display by unscrewing the two mounting screws.

# SECTION D

## Resistance & Buzzer Circuit

### PARTS LIST - SECTION D

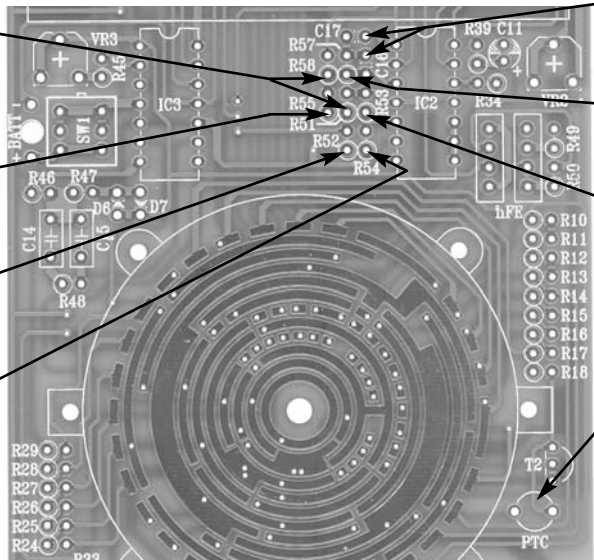
| RESISTORS |              |             |                           |        |
|-----------|--------------|-------------|---------------------------|--------|
| Qty.      | Symbol       | Description | Color Code                | Part # |
| □ 1       | R54          | 10kΩ 5%     | brown-black-orange-gold   | 151000 |
| □ 1       | R52          | 100kΩ 5%    | brown-black-yellow-gold   | 161000 |
| □ 2       | R55, R57     | 330kΩ 5%    | orange-orange-yellow-gold | 163300 |
| □ 4       | R51,53,56,58 | 1MΩ 5%      | brown-black-green-gold    | 171000 |
| □ 1       | PTC          | 1.5kΩ       | Thermister                | 190416 |


| CAPACITORS |          |              |             |        |
|------------|----------|--------------|-------------|--------|
| Qty.       | Symbol   | Value        | Description | Part # |
| □ 2        | C16, C17 | .001μF (102) | Discap      | 231036 |

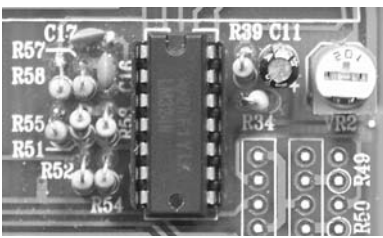
| MISCELLANEOUS |        |       |                    |        |
|---------------|--------|-------|--------------------|--------|
| Qty.          | Symbol | Value | Description        | Part # |
| □ 1           | Buz    |       | Buzzer (20mm dia.) | 595220 |

### ASSEMBLE THE FOLLOWING COMPONENTS TO THE PC BOARD

- R58 - 1MΩ 5% 1/4W Res. (brown-black-green-gold) (see Figure I)
- R51 - 1MΩ 5% 1/4W Res. (brown-black-green-gold) (see Figure I)
- R55 - 330kΩ 5% 1/4W Res. (orange-orange-yellow-gold) (see Figure I)
- R52 - 100kΩ 5% 1/4W Res. (brown-black-yellow-gold) (see Figure I)
- R54 - 10kΩ 5% 1/4W Res. (brown-black-orange-gold) (see Figure I)



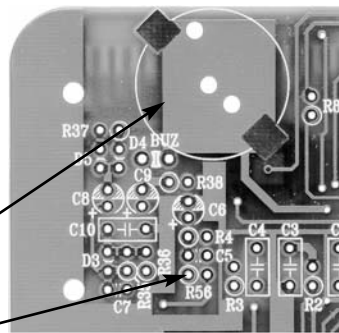
- C17 - .001μF (102) Discap
  - C16 - .001μF (102) Discap
  - R57 - 330kΩ 5% 1/4W Res. (orange-orange-yellow-gold) (see Figure I)
  - R53 - 1MΩ 5% 1/4W Res. (brown-black-green-gold) (see Figure I)
  - PTC - 1.5kΩ Thermister
- 



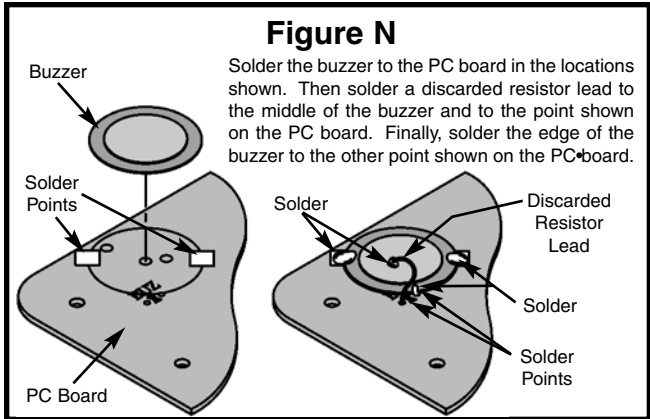
**Assembled View**

**Top Legend Side**

- BUZ - Buzzer (see Figure N)
- R56 - 1MΩ 5% 1/4W Res. (brown-black-green-gold) (see Figure I)



**Bottom Legend Side**



**Figure N**

Solder the buzzer to the PC board in the locations shown. Then solder a discarded resistor lead to the middle of the buzzer and to the point shown on the PC board. Finally, solder the edge of the buzzer to the other point shown on the PC board.

- Attach the LCD to the PC board using the two 2.5 x 8mm screws. Use the top-mounting hole and lightly tighten the screws. The screws will be removed to assemble the next section.

### Testing Procedure

1. Place the top label over the knob and turn the range selector knob to an OHM scale position.
2. Connect the 9V battery to the battery snap.
3. Connect the test leads (red lead to VΩ CAP and black to COM). Turn the meter on by pressing the power switch.
4. Test the Ohms, Buzzer, and Diode functions using the procedures below.

**OHMs** - Using two or three different value resistors, check each scale. Compare the kit meter readings

with another meter of known accuracy. If the tests are not working, check the solder of the PTC.

**Buzzer** - Set the selector knob to the Buzzer (🔊) position. Short the red and black leads and the buzzer should sound. If the buzzer does not sound, check components R51-R58, PTC, C16, C17, and the solder connections to the buzzer.

**Diode** - Connect a diode to the test leads with the correct polarity (see figure below). The meter will range for 100 - 950.



5. Turn the meter off and remove the battery, top label, and test leads.
6. Remove two display mounting screws and display by unscrewing the two mounting screws.

**DO NOT PROCEED TO SECTION E WITHOUT INSTRUCTOR'S APPROVAL.**

# SECTION E

## Capacitance and Transistor Testing Circuit

### PARTS LIST - SECTION E

#### RESISTORS

| Qty. | Symbol   | Description    | Color Code                      | Part # |
|------|----------|----------------|---------------------------------|--------|
| □ 1  | R29      | 10Ω 1% 1/4W    | brown-black-black-gold-brown    | 121030 |
| □ 1  | R28      | 90Ω 1% 1/4W    | white-black-black-gold-brown    | 129030 |
| □ 1  | R45      | 150Ω 1% 1/4W   | brown-green-black-black-brown   | 131530 |
| □ 1  | R27      | 900Ω 1% 1/4W   | white-black-black-black-brown   | 139030 |
| □ 1  | R42      | 1.91kΩ 1% 1/4W | brown-white-brown-brown-brown   | 141930 |
| □ 1  | R43      | 4.3kΩ 1% 1/4W  | yellow-orange-black-brown-brown | 144330 |
| □ 1  | R26      | 9kΩ 1% 1/4W    | white-black-black-brown-brown   | 149030 |
| □ 1  | R44      | 10kΩ 1% 1/4W   | brown-black-black-red-brown     | 151030 |
| □ 1  | R47      | 11kΩ 1% 1/4W   | brown-brown-black-red-brown     | 151130 |
| □ 2  | R40, R41 | 39kΩ 1% 1/4W   | orange-white-black-red-brown    | 153930 |
| □ 1  | R46      | 76.8kΩ 1% 1/4W | violet-blue-gray-red-brown      | 157630 |
| □ 1  | R25      | 90kΩ 1% 1/4W   | white-black-black-red-brown     | 159030 |
| □ 1  | R48      | 160kΩ 1% 1/4W  | brown-blue-black-orange-brown   | 161630 |
| □ 2  | R49, R50 | 220kΩ 5% 1/4W  | red-red-yellow-gold             | 162200 |
| □ 1  | R24      | 900kΩ 1% 1/4W  | white-black-black-orange-brown  | 169030 |
| □ 1  | VR3      | 200Ω (201)     | Trim Pot                        | 191320 |

**Note:** Resistor tolerance (last band) of 5-band resistors may be green instead of brown.

#### CAPACITORS

| Qty. | Symbol    | Value       | Description         | Part #  |
|------|-----------|-------------|---------------------|---------|
| □ 4  | C12 - C15 | .01μF (103) | Mylar (large brown) | 241017L |

#### SEMICONDUCTORS

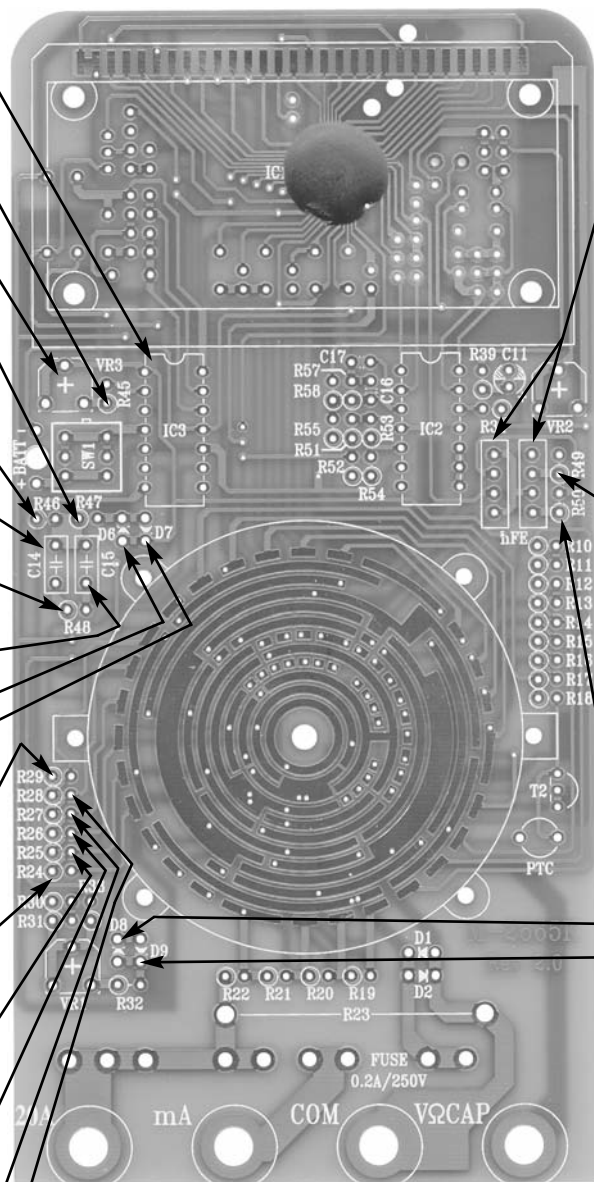
| Qty. | Symbol  | Value  | Description | Part # |
|------|---------|--------|-------------|--------|
| □ 4  | D6 - D9 | 1N4001 | Diode       | 314001 |
| □ 1  | IC3     | LM324  | Op-Amp      | 330324 |

#### MISCELLANEOUS

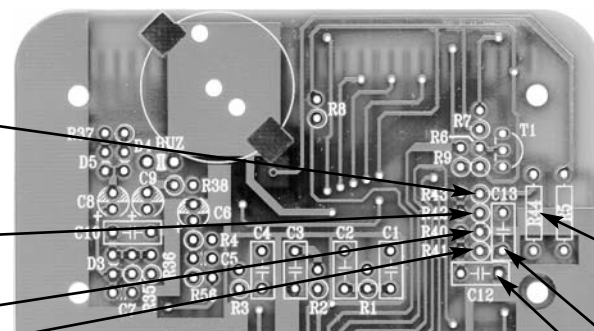
| Qty. | Symbol | Value | Description      | Part # |
|------|--------|-------|------------------|--------|
| □ 1  |        |       | IC Socket 14-pin | 664014 |
| □ 2  |        |       | hFE Socket       | 664015 |

# ASSEMBLE THE FOLLOWING COMPONENTS TO THE PC BOARD

- IC Socket 14-pin
- IC3 - LM324 Op-Amp IC  
(see Figure M)
- R45 - 150Ω 1% 1/4W Res.  
(brn-green-blk-blk-brn)  
(see Figure I)
- VR3 - 200Ω Pot
- R47 - 11kΩ 1% 1/4W Res.  
(brn-brn-blk-red-brn)  
(see Figure I)
- R46 - 76.8kΩ 1% 1/4W Res.  
(violet-blue-gray-red-brn)  
(see Figure I)
- C14 - .01μF (103) Mylar Cap.
- R48 - 160kΩ 1% 1/4W Res.  
(brn-blue-black-orange-brn)  
(see Figure I)
- C15 - .01μF (103) Mylar Cap.
- D6 - 1N4001 Diode
- D7 - 1N4001 Diode  
(see Figure O)
- R29 - 10Ω 1% 1/4W Res.  
(brn-blk-blk-gold-brn)  
(see Figure I)
- R24 - 900kΩ 1% 1/4W Res.  
(white-black-black-org-brown)  
(see Figure I)
- R25 - 90kΩ 1% 1/4W Res.  
(white-black-black-red-brown)  
(see Figure I)
- R26 - 9kΩ 1% 1/4W Res.  
(white-black-black-brn-brn)  
(see Figure I)
- R27 - 900Ω 1% 1/4W Res.  
(white-blk-blk-blk-brown)  
(see Figure I)
- R28 - 90Ω 1% 1/4W Res.  
(white-blk-blk-gold-brown)  
(see Figure I)
- R43 - 4.3kΩ 1% 1/4W Res.  
(yellow-orange-blk-brn-brn)  
(see Figure I)
- R42 - 1.91kΩ 1% 1/4W Res.  
(brn-white-brn-brn-brn)  
(see Figure I)
- R40 - 39kΩ 1% 1/4W Res.
- R41 - 39kΩ 1% 1/4W Res.  
(orange-white-blk-red-brn)  
(see Figure I)

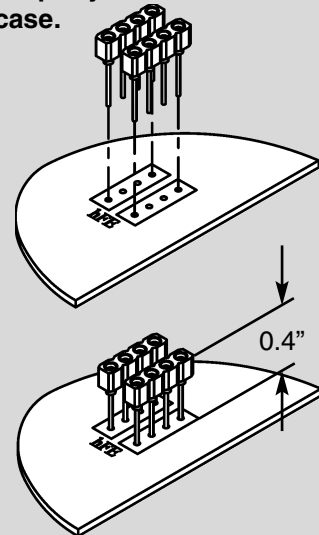


**Top Legend Side**



**Bottom Legend Side**

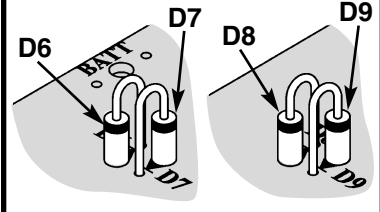
- hFE - Sockets - Install these with no more than 0.4" of height from the PC board to the top of the sockets. Otherwise, the top case will not fit together properly with the bottom case.



- R49 - 220kΩ 5% 1/4W Res.  
(red-red-yellow-gold)  
(see Figure I)
- R50 - 220kΩ 5% 1/4W Res.  
(red-red-yellow-gold)  
(see Figure I)
- D8 - 1N4001 Diode
- D9 - 1N4001 Diode  
(see Figure O)

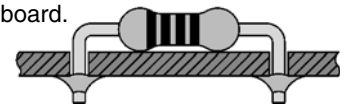
**Figure O**

Stand diode on end. Mount with band as shown on the top legend.

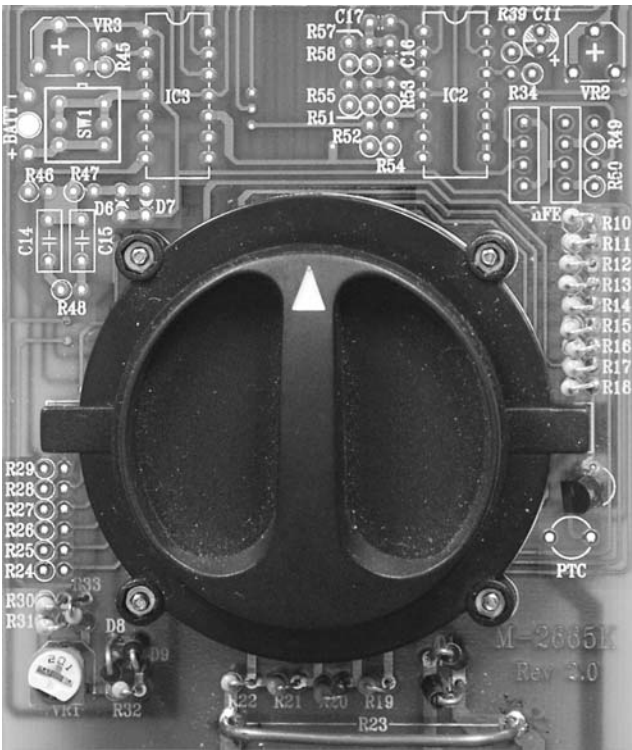


**Figure P**

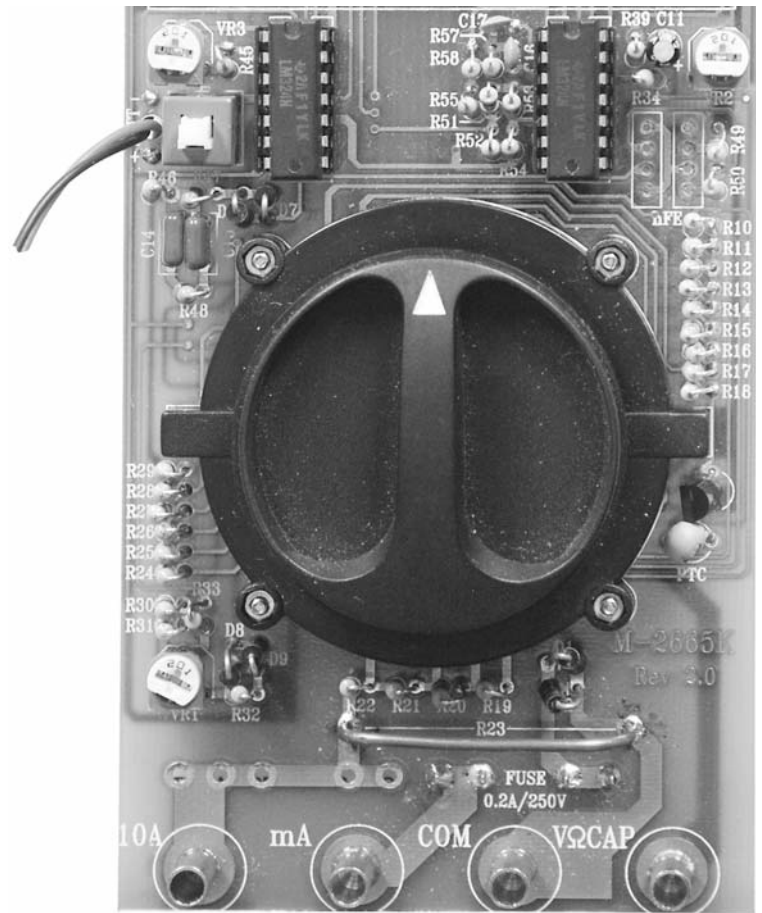
Lay resistor flat against the PC board.



- R44 - 10kΩ 1% 1/4W Res.  
(brn-blk-blk-red-brn)  
(see Figure P)
- C13 - .01μF (103) Mylar Cap.
- C12 - .01μF (103) Mylar Cap.



**Assembled View for Section B**

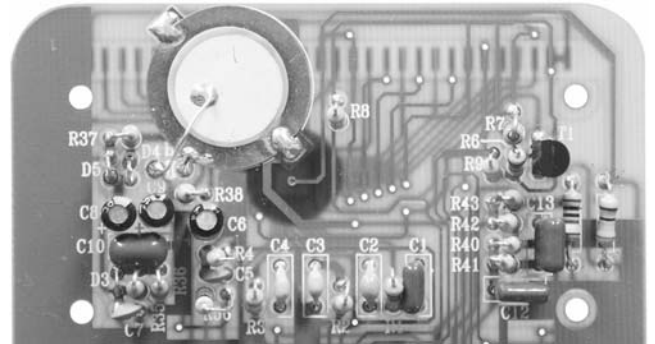


- Attach the LCD to the PC board using the two 2.5 x 8mm screws. Use the top-mounting hole and lightly tighten the screws.

**Testing Procedure**

**Capacitance**

1. Place the top label over the knob and turn the range selector knob to a capacitance (C) scale position.
2. Connect the 9V battery to the battery snap.
3. Connect the short test leads (red lead to VΩ CAP and black to COM). Turn the meter on by pressing the power switch.
4. **Capacitance** - Measure a cap with another meter and then connect the capacitor to the meter leads. Adjust VR3 so that the meter reads the same as the accurate one. This calibrates capacitance circuit of meter. Using two or three different value capacitors, check each scale. If the test is not working check components R40 - R48, VR3, C12 - C15, D6 - D9, and IC3.



**Assembled Views for Section E**

**Transistor** - Set the meter in the hFE scales. Place an NPN transistor into the socket. Make sure that the transistor is in correctly. Depending on the type of transistor, the meter will range from 20 to 550. Place a PNP transistor into the PNP socket; the range will also be 20 to 550. If the tests are not working, check components R49 - R50, and the transistor sockets.

5. Turn the meter off and remove the battery, top label, and test leads.

**DO NOT PROCEED TO SECTION F WITHOUT INSTRUCTOR'S APPROVAL.**

# SECTION F

## Final Assembly

### PARTS LIST - SECTION F

| Qty. | Description                 | Part # | Qty. | Description           | Part # |
|------|-----------------------------|--------|------|-----------------------|--------|
| □ 1  | Button (red)                | 622027 | □ 2  | Screw Case 3 x 17.5mm | 642240 |
| □ 3  | Sleeve Input Socket (red)   | 622660 | □ 1  | Spring                | 680033 |
| □ 1  | Sleeve Input Socket (black) | 622661 | □ 1  | Label Bottom          | 723052 |
| □ 1  | Case Top                    | 623112 | □ 1  | Shield Label          | 780012 |
| □ 1  | Case Bottom                 | 623203 | □ 1  | Holster               | 9C72   |
| □ 1  | Cover Battery               | 623210 | □ 1  | Test Leads Alligator  | 9TL13  |
| □ 2  | Screw LCD Housing 2.5 x 8mm | 642239 | □ 1  | Test Leads Red-Black  | 9TL14  |

**Note:** The shield may be installed already.

### FINAL ASSEMBLY

- Solder the spring to the PC board as shown in Figure Q.
- Install the bottom two 2.5 x 8mm screws to the LCD housing as shown in Figure R.
- Peel off the protective backing on the top label (A) and bottom label (B) and stick them to the top case as shown in Figure S.
- Place the PC board into the bottom case. Feed the battery clip through the case as shown in Figure T.
- Place the four colored sleeves over the input sockets as shown in Figure T. Note that the black sleeve goes on the COM socket.
- Place the red power cap onto the switch SW1 as shown in Figure T.

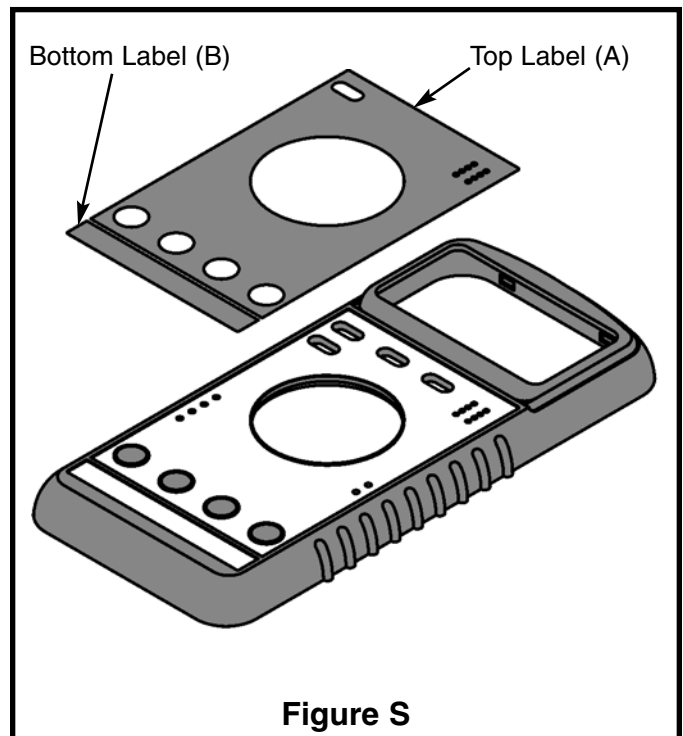
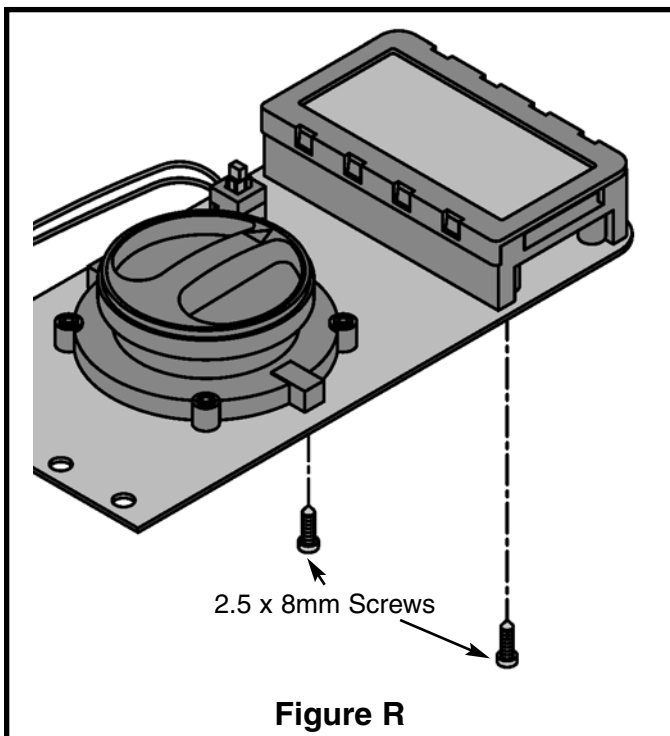
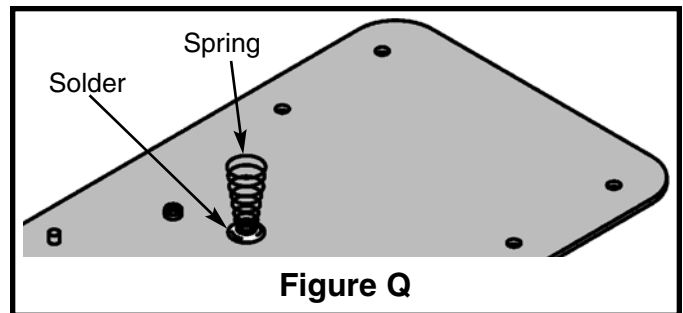
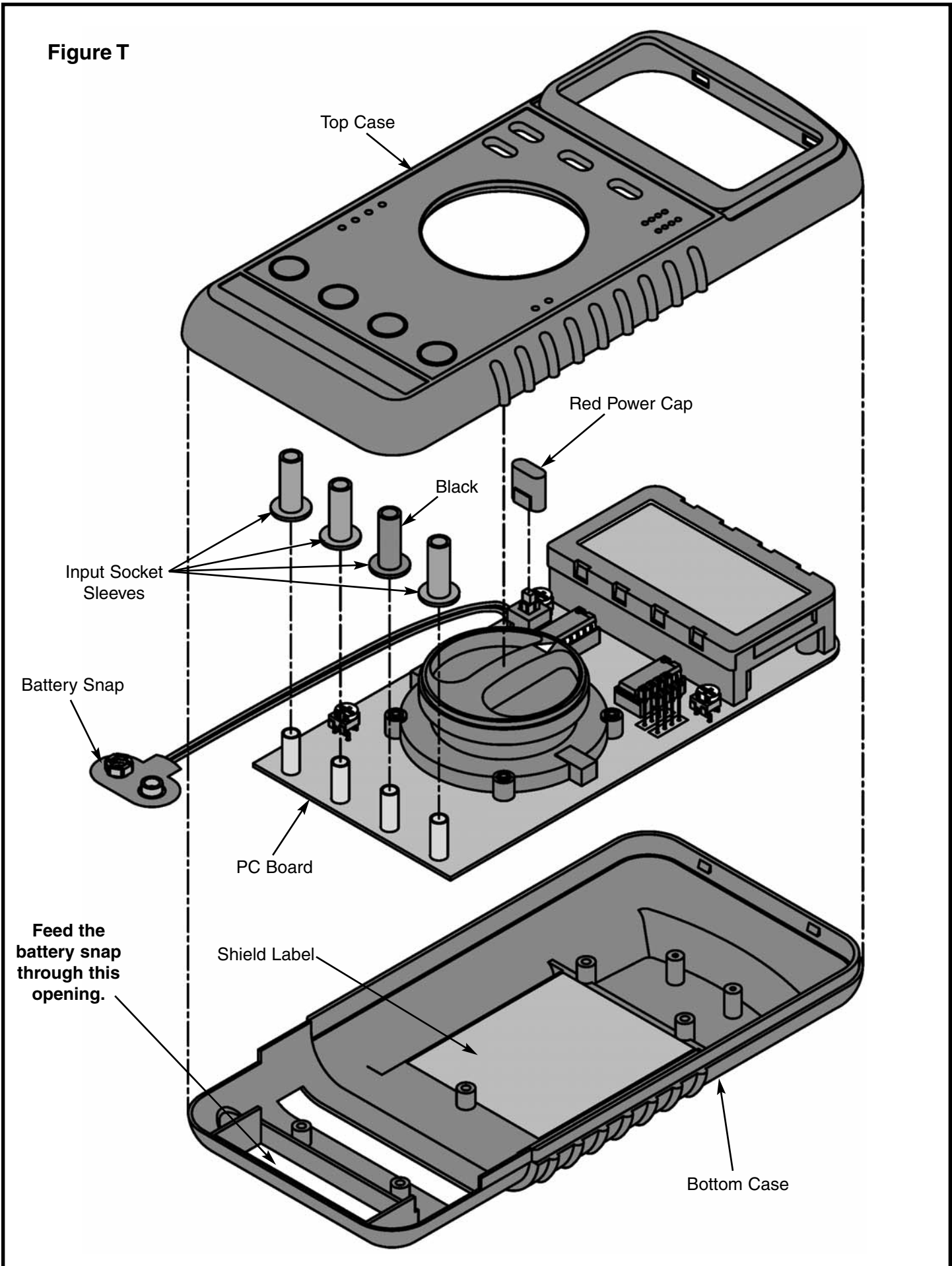


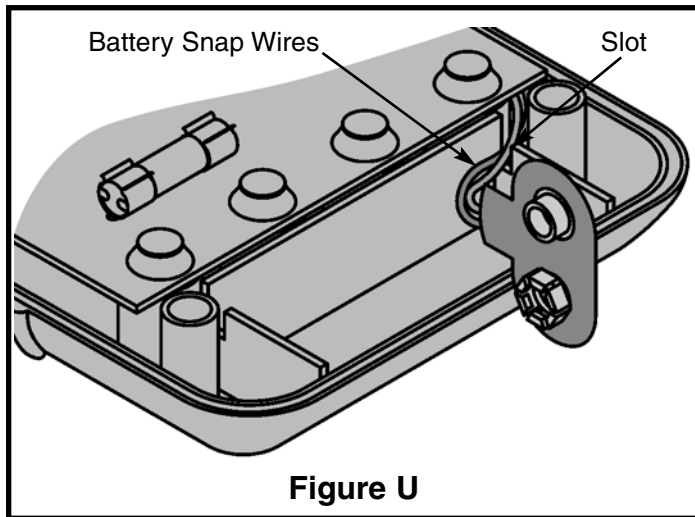
Figure T



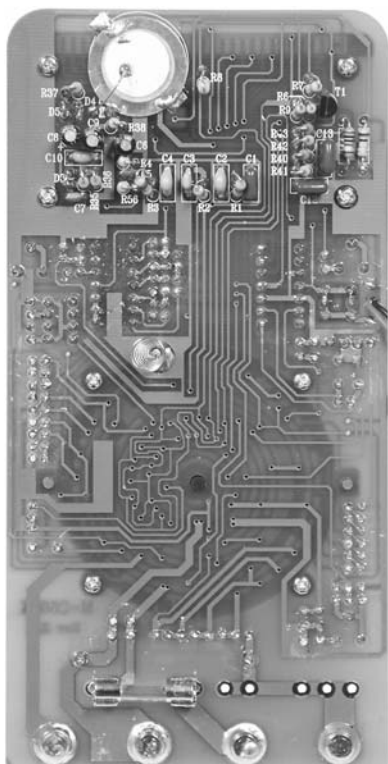
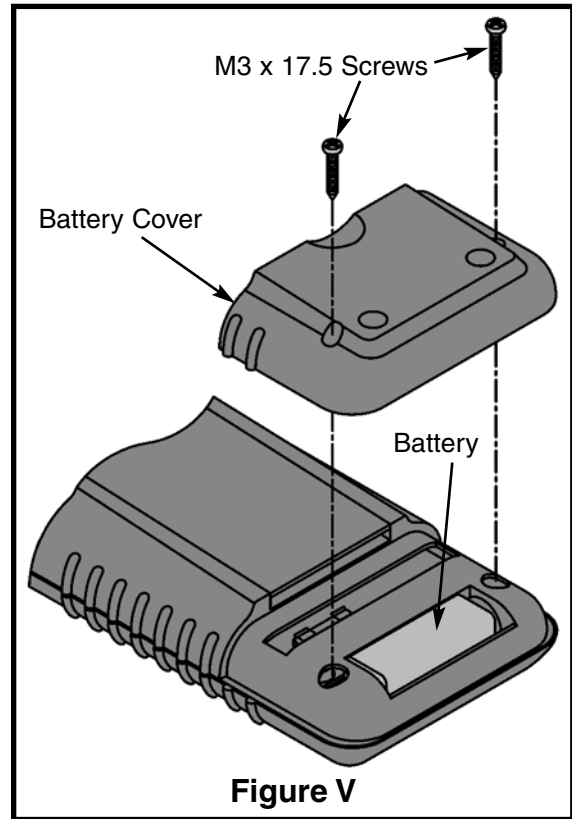


## FINAL ASSEMBLY (continued)

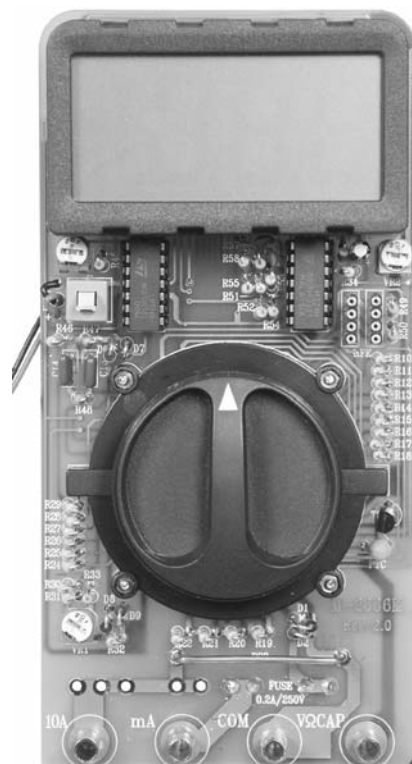
- ❑ Feed the battery snap wires through the slot on the top case as shown in Figure U.
- ❑ Connect the battery and place it in the cavity of the top case as shown in Figure V.



- ❑ Place the battery cover onto the case as shown in Figure V. Hold the two sections together with two M3 x 17.5 screws.



Assembled PC Board (Back View)



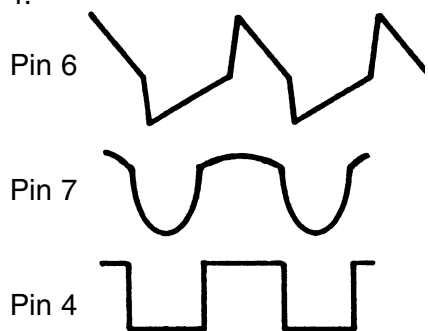
Assembled PC Board (Front View)

## TROUBLESHOOTING GUIDE

If the meter is not working, perform the U1 (7106) Voltage Test first. This test is to verify that the IC and Reference Voltage are operational. Then perform

### U1 (7106) Voltage Test

1. Measure the voltage across pin 8 and pin 34 on U1 (7106) for 9V.
  - A. Check the battery and SW1 connections.
  - B. Check for a 9V and GND short.
    1. One of the ICs may be bad. Remove one IC at a time and check voltage again between pins 8 and 34.
2. Measure the voltage from pin 8 to COM on U1 for 3V.
  - A. U1 is defective.
3. Check the Main Oscillator on U1 (7106) pins 6, 7, and 4.



4. Measure the voltage from pin 44 to COM on U1 (7106) = 0.1V.
  - A. Adjust VR1 so the the junction of R31, R33 and VR1 equal to 100mV.
    1. Can't set to 100mV.
      - a. VR1 wrong value or defective.
      - b. R30 - R32 wrong value.

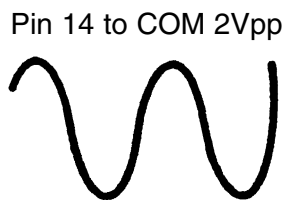
the tests that pertain to the Function that is not working on your meter.

### Voltage/OHM Section

1. Measure across VΩCAP terminal and COM terminal for 10MΩ (set meter in 200mV) battery installed.
  - A. Lower or higher than 10MΩ.
    1. Check resistors R10 - R18.
2. LCD readings floating.
  - A. Measure from COM terminal to pin 43 on U1 (7106) for 220kΩ.
    1. R3 open or defective.

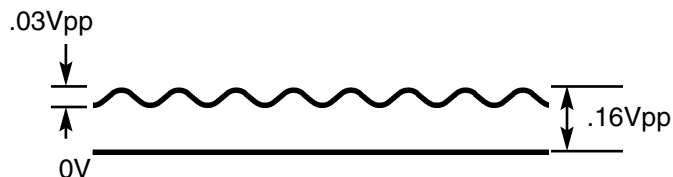
### AC Voltage Section

1. Apply 15VAC to meter and measure pin 14 of U2 (324) to COM terminal with a scope (meter on 20VAC scale).



- A. Check IC2 and R34
2. Check junction R39 and C11 of U1 (7106) with a scope.

Waveform for junction R39 and C11.



- A. Check R35 - R39, C7 - C11, D3 - D5, and VR2.

## Amps Section

1.  $\mu\text{A}/\text{mA}$  scale not working:

A. Check fuse.

B. Measure across ( $\mu\text{A}/\text{mA}$ ) terminal and (COM) terminal and check the following settings:

$$200\mu = 1\text{k}\Omega \quad 2\text{m} = 100\Omega$$

$$20\text{m} = 10\Omega \quad 200\text{m} = 1\Omega$$

1. Lower or higher check R19 - R23.

2. 10A scale not working:

A. Check shunt.

## Capacitance Section

1. Connect the  $.1\mu\text{F}$  cap to the meter and check pin 14 and pin 1 of U3 with a scope (meter set to 2N).

Pin 14 350Hz - 400Hz 5Vpp.



Pin 1 350Hz - 400Hz .14Vpp.



A. No signal at pin 14.

1. Check R40 - R43, C12, C13, and IC3.

B. No signal at pin 1 but present at pin 14.

1. Check R44, R45, VR1, D6, and D7.

Pin 8 350Hz - 400Hz .3Vpp.



C. No signal at pin 8.

1. Check R46 - R48, D8, D9, C14, and C15.

## $h_{FE}$ Section

1. Check for shorts on socket pins.

2. Measure across base (B) terminal to COM terminal for  $209\text{k}\Omega$  to  $231\text{k}\Omega$ .

A. Lower or higher than value; Check R49 (NPN) and R50 (PNP).

## Decimal Point Section

1. Displays two decimal points.

A. Shorted resistors R7 - R9.

2. No decimal points displayed.

A. Check R7 - R9.

## Diode

1. Measure voltage across V OHM and COM terminal (set in diode mode) = 3V.

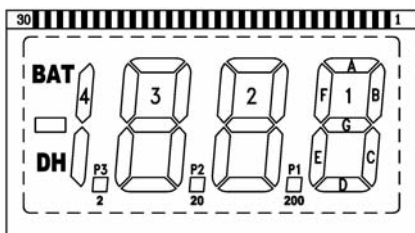
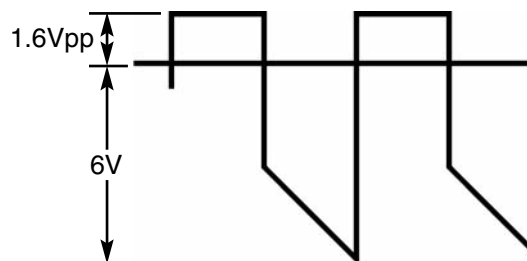
A. Low voltage, check R51, R53, and R54.

## Buzzer

### U2 Voltages

| No Sound |      | Sound |       |
|----------|------|-------|-------|
| Pin 1    | -5.5 | Pin 1 | -1.87 |
| Pin 2    | -5.5 | Pin 2 | -1.87 |
| Pin 3    | -5.5 | Pin 3 | -1.87 |
| Pin 4    | 3    | Pin 4 | 3     |
| Pin 5    | 0    | Pin 5 | 0     |
| Pin 6    | 3    | Pin 6 | 0     |
| Pin 7    | -5.5 | Pin 7 | 1.87  |

Pin 1 of IC2 - 1.5kHz.

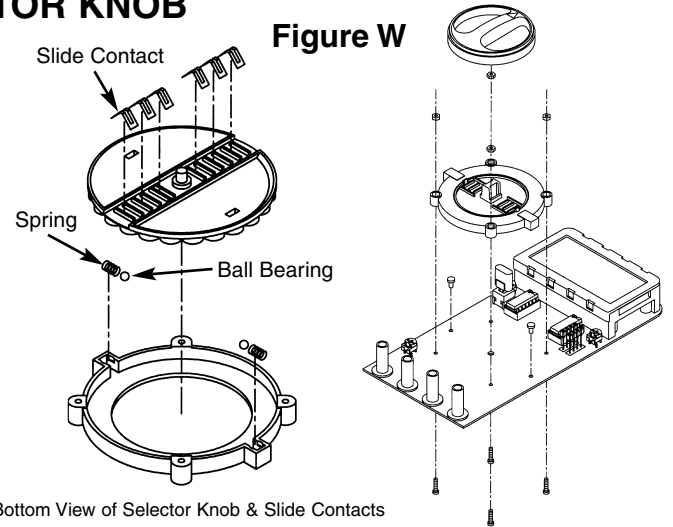


|     |     |    |    |    |         |     |          |     |           |     |
|-----|-----|----|----|----|---------|-----|----------|-----|-----------|-----|
| PIN | 1   | 2  | 3  | 4  | 5       | 6   | 7        | 8   | 9         | 10  |
| COM | COM | D1 | C1 | B1 | A1      | F1  | G1       | E1  | P1<br>200 | D2  |
| PIN | 11  | 12 | 13 | 14 | 15      | 16  | 17       | 18  | 19        | 20  |
| COM | C2  | B2 | A2 | F2 | G2      | E2  | P2<br>20 | D3  | C3        | B3  |
| PIN | 21  | 22 | 23 | 24 | 25      | 26  | 27       | 28  | 29        | 30  |
| COM | A3  | F3 | G3 | E3 | P3<br>2 | BC4 | □        | BAT | DH        | COM |

## REINSTALLATION OF THE RANGE SELECTOR KNOB

If you removed the rotary selector knob for troubleshooting, then follow the instructions below to reinstall it.

Place the PC board over the range selector knob and fasten the knob to the PC board with a M2.3 x 8 screw. **CAUTION:** Do not over-tighten the screw. The knob should be snug, but not loose. Turn back the M2.3 x 8 screw 1/2 turn. Slip the two shims under the knob (see Figure W). If they do not slip in, turn back the screw another 1/4 turn. Tighten the screw just enough so that the shims can be pulled out. You should now have the proper tension to hold the knob and contacts in place and rotate the knob to the desired positions.



| Qty. | Description                         | Part #  |
|------|-------------------------------------|---------|
| 1    | Selector Switch 2 psc.              | 622666  |
| 2    | Selector Pin                        | 622666A |
| 6    | Slide Contacts                      | 622666B |
| 4    | Screws - Selector Switch M1.8 x 8mm | 622666C |

| Qty. | Description                | Part #  |
|------|----------------------------|---------|
| 4    | Nut - Selector Switch M1.8 | 622666D |
| 2    | Ball Bearing               | 622666E |
| 2    | Spring - Selector          | 622666F |

## USING THE DIGITAL MULTIMETER

Familiarize yourself with your new digital meter by taking readings of known resistances and voltages. You will find that the readings will not be as accurate on certain ranges for a given measurement. For example, when measuring a low resistance on a high range, the reading will show a short 0.00. When measuring a high resistance on a low range, the reading will show infinity 1. Likewise, it is important

to use the correct range when measuring voltages. Table 1 shows an example of the readouts for different values of resistance. Table 2 shows an example of the readouts for 117VAC and 100VDC. The shaded area indicates the most accurate range. It must be remembered that the readings will shift slightly when switching to a different range.

| MEASURED RESISTANCE       | RANGE SETTING |      |       |       |      |      |
|---------------------------|---------------|------|-------|-------|------|------|
|                           | 200Ω          | 2kΩ  | 20kΩ  | 200kΩ | 2MΩ  | 20MΩ |
| SHORT<br>(LEADS TOUCHING) | * 00.1        | .000 | 0.00  | 00.0  | .000 | 0.00 |
| INFINITY                  | 1 .           | 1.   | 1 .   | 1 .   | 1.   | 1 .  |
| 47Ω                       | 52.1          | .052 | 0.05  | 00.0  | .000 | 0.00 |
| 270Ω                      | 1 .           | .267 | 0.26  | 00.2  | .000 | 0.00 |
| 10kΩ                      | 1 .           | 1.   | 10.18 | 10.2  | .010 | 0.01 |
| 47kΩ                      | 1 .           | 1.   | 1 .   | 52.7  | .052 | 0.05 |
| 470kΩ                     | 1 .           | 1.   | 1 .   | 1 .   | .472 | 0.47 |
| 2.2MΩ                     | 1 .           | 1.   | 1 .   | 1 .   | 1.   | 2.12 |

\* RESISTANCE OF TEST LEADS

Table 1

Table 2

| MEASURED VOLTAGE | 200mV | 2V | 20V | 200V  | 1000V |
|------------------|-------|----|-----|-------|-------|
| 120VAC           | 1 .   | 1. | 1 . | 120.0 | 120   |
| 100VDC           | 1 .   | 1. | 1 . | 100.0 | 100   |

---

## 1. FEATURES

- Wide measuring ranges: 34 ranges for AC/DC Voltage and Current, Resistance, Capacitance, TR  $h_{FE}$ , Diode Test, and Continuity Buzzer.
- 10M $\Omega$  Input Impedance
- Big LCD for easy reading
- Tilt Stand
- Rubber Holster

---

## 2. SPECIFICATIONS

### 2-1 General Specifications

|                          |   |
|--------------------------|---|
| Display                  | 3 1/2 LCD 0.9" height, maximum reading of 1999.   |
| Polarity                 | Automatic "-" sign for negative polarity.   |
| Overrange Indication     | Highest digit of "1" or "-1" is displayed.  |
| Low Battery Indication   | "BAT" lettering on the LCD readout.   |
| Operating Temperature    | 0°C to 50°C.<br>less than 80% relative humidity up to 35°C.<br>less than 70% relative humidity from 35°C to 50°C. |
| Storage Temperature      | -15°C to 50°C   |
| Temperature Coefficient  | 0°C to 18°C and 28°C to 50°C.<br>less than 0.1 x applicable accuracy specification per degree C.                  |
| Power                    | 9V alkaline or carbon zinc battery (NEDA 1604).   |
| Battery Life (typical)   | 100 hours with carbon zinc cells.<br>200 hours with alkaline cells.   |
| Dimensions (w/o holster) | 3.55" (90.2mm) (W) x 7.6" (193mm) (L) x 1.78" (45.2mm) (H).   |
| Weight (w/o holster)     | Approximately 10.4oz. (300g.)   |
| Accessories              | Safety Test Leads 1 pair  |

### 2-2 Measurement Ranges (Accuracy: 1 year 18°C to 28°C)

#### DC Voltage

| Range | Resolution  | Accuracy                       | Maximum Input       |
|-------|-------------|--------------------------------|---------------------|
| 200mV | 100 $\mu$ V | $\pm 0.5\%$ of rdg $\pm 2$ dgt | DC 1000V or peak AC |
| 2V    | 1mV         | $\pm 0.5\%$ of rdg $\pm 2$ dgt |                     |
| 20V   | 10mV        | $\pm 0.5\%$ of rdg $\pm 2$ dgt |                     |
| 200V  | 100mV       | $\pm 0.5\%$ of rdg $\pm 2$ dgt |                     |
| 1000V | 1V          | $\pm 0.8\%$ of rdg $\pm 2$ dgt |                     |

Normal Mode Rejection Ratio: Greater than 46dB at 50Hz 60Hz (1k unbalance)

## AC Voltage

| Range | Resolution  | Accuracy                      | Maximum Input                |
|-------|-------------|-------------------------------|------------------------------|
| 200mV | 100 $\mu$ V | $\pm 1.5\%$ of rdg $\pm$ 2dgt | AC 750V maximum 50Hz - 400Hz |
| 2V    | 1mV         | $\pm 1\%$ of rdg $\pm$ 2dgt   |                              |
| 20V   | 10mV        | $\pm 1\%$ of rdg $\pm$ 2dgt   |                              |
| 200V  | 100mV       | $\pm 1\%$ of rdg $\pm$ 2dgt   |                              |
| 750V  | 1V          | $\pm 1.5\%$ of rdg $\pm$ 2dgt |                              |

## Resistance

| Range         | Resolution   | Accuracy                      | Test Current           | Input Protection    |
|---------------|--------------|-------------------------------|------------------------|---------------------|
| 200 $\Omega$  | 0.1 $\Omega$ | $\pm 1\%$ of rdg $\pm$ 2dgt   | Approximately<br>1.2mA | Protected By<br>PTC |
| 2k $\Omega$   | 1 $\Omega$   | $\pm 0.8\%$ of rdg $\pm$ 2dgt |                        |                     |
| 20k $\Omega$  | 10 $\Omega$  | $\pm 0.8\%$ of rdg $\pm$ 2dgt |                        |                     |
| 200k $\Omega$ | 100 $\Omega$ | $\pm 0.8\%$ of rdg $\pm$ 2dgt |                        |                     |
| 2M $\Omega$   | 1k $\Omega$  | $\pm 0.8\%$ of rdg $\pm$ 3dgt |                        |                     |
| 20M $\Omega$  | 10k $\Omega$ | $\pm 2.0\%$ of rdg $\pm$ 4dgt |                        |                     |

Maximum open circuit voltage: 2.8V

## DC Current

| Range       | Resolution  | Accuracy                      | Protection                   |
|-------------|-------------|-------------------------------|------------------------------|
| 200 $\mu$ A | 100nA       | $\pm 1.5\%$ of rdg $\pm$ 2dgt | Protected by<br>250V/2A Fuse |
| 2mA         | 1 $\mu$ A   | $\pm 1.5\%$ of rdg $\pm$ 2dgt |                              |
| 20mA        | 10 $\mu$ A  | $\pm 1.5\%$ of rdg $\pm$ 2dgt |                              |
| 200mA       | 100 $\mu$ A | $\pm 2\%$ of rdg $\pm$ 2dgt   |                              |
| 20A         | 10mA        | $\pm 2.5\%$ of rdg $\pm$ 3dgt |                              |

## AC Current

| Range       | Resolution  | Accuracy                      | Protection                   |
|-------------|-------------|-------------------------------|------------------------------|
| 200 $\mu$ A | 100nA       | $\pm 1\%$ of rdg $\pm$ 3dgt   | Protected by<br>250V/2A Fuse |
| 2mA         | 1 $\mu$ A   | $\pm 1\%$ of rdg $\pm$ 3dgt   |                              |
| 20mA        | 10 $\mu$ A  | $\pm 1\%$ of rdg $\pm$ 3dgt   |                              |
| 200mA       | 100 $\mu$ A | $\pm 1.5\%$ of rdg $\pm$ 3dgt |                              |
| 20A         | 10mA        | $\pm 2.0\%$ of rdg $\pm$ 3dgt |                              |

## Capacitance

| Range       | Resolution | Accuracy                      | Protection           |
|-------------|------------|-------------------------------|----------------------|
| 2nF         | 1pF        | $\pm 2.5\%$ of rdg $\pm$ 3dgt | Test frequency 400Hz |
| 2nF         | 10pF       | $\pm 2.5\%$ of rdg $\pm$ 3dgt |                      |
| 200nF       | 100pF      | $\pm 2.5\%$ of rdg $\pm$ 3dgt |                      |
| 2 $\mu$ F   | 1nF        | $\pm 2.5\%$ of rdg $\pm$ 3dgt |                      |
| 20 $\mu$ F  | 10nF       | $\pm 2.5\%$ of rdg $\pm$ 3dgt |                      |
| 200 $\mu$ F | 100nF      | $\pm 5\%$ of rdg $\pm$ 3dgt   |                      |

## Transistor $h_{FE}$

| Range | Test Condition |
|-------|----------------|
| NPN   | 2mA 3V         |
| PNP   | 2mA 3V         |

## Diode Test

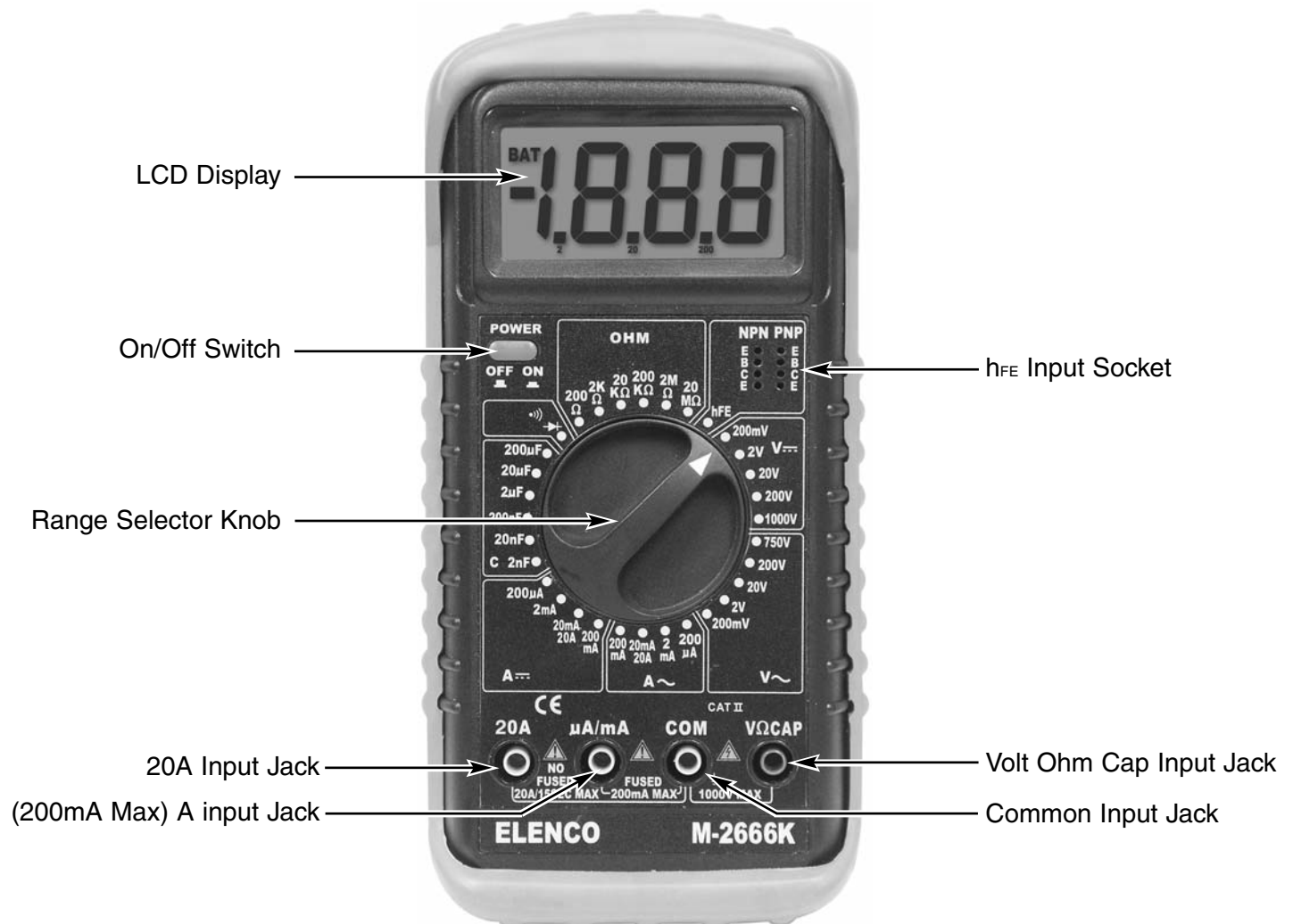
Measures forward resistance of a semiconductor junction in k Ohm at max. test current of 1mA.

## 3. OPERATION

### 3-1 Preparation and caution before measurement

1. If the function must be switched during a measurement, always remove the test leads from the circuit being measured.
2. If the unit is used near noise generating equipment, be aware that the display may become unstable or indicate large errors.
3. Avoid using the unit in places with rapid temperature variations.
4. In order to prevent damage or injury to the unit, never fail to keep the maximum tolerable voltage and current, especially for the 20A current range.
5. Carefully inspect the test lead. If damaged, discard and replace.

### 3-2 Panel Description



### 3-3 Method of Measurement

#### (A) DC/AC Voltage Measurement

1. Connect the red test lead to “VΩCAP” input jack and the black one to the “COM” jack.
2. Turn the meter on by pressing the power switch.
3. Set the range selector knob to the desired volt position. If the magnitude of the voltage is not known, set the range selector knob to the highest range and reduce until a satisfactory reading is obtained.
4. Connect the test leads to the device or circuit being measured.
5. Turn on the power to the device or circuit being measured. The voltage value will appear on the digital display along with the voltage polarity.
6. Turn off the power to the device or circuit being tested and discharge all of the capacitors prior to disconnecting the test leads.

#### (B) DC/AC Current Measurement

1. Connect the red test lead to the “A” input jack for current measurement up to 200mA, and the black one to “COM”.
2. Turn the meter on by pressing the power switch.
3. Set the range selector knob to the desired “Amp” current position.


If the magnitude of current is not known, set the range selector knob to the highest range and reduce until a satisfactory reading is obtained.

4. Open the circuit to be measured, and connect the test leads in series with the load in which current is to be measured.
5. Read the current value on the digital display.
6. Turn off all power to the circuit being tested and discharge all of the capacitor prior to disconnecting the test lead.
7. To measure in the 20A range, use the “20A” jack as the input jack. Be sure to measure within 10 seconds to avoid high-current hazard.

#### (C) Resistance Measurement

1. Connect red test lead to the “VΩCAP” input jack and the black one to “COM”.
2. Turn the meter on by pressing the power switch.
3. Set the range selector knob to desired “Ohm” position.
4. If the resistance being measured is connected to a circuit, turn off the power to the circuit being tested and discharge all capacitors.
5. Connect the test leads to the circuit being measured. When measuring high resistance, be sure not to contact adjacent point even if insulated, because some insulators have a relatively low insulation resistance, causing the measured resistance to be lower than the actual resistance.
6. Read resistance value on digital display.

#### (D) Diode Test

1. Connect the red test lead to “VΩCAP” input jack and the black one to the “COM” jack.
2. Turn the meter on by pressing the power switch.
3. Set the range selector knob to the “  ” position.
4. If the semiconductor junction being measured is connected to the circuit, turn off the power to the circuit being tested and discharge all of the capacitors.
5. Connect the test leads to the device and read forward value on the digital display.
6. If the digital reads overrange (1), reverse the lead connections.

The placement of the test leads when the forward reading is displayed indicates the orientation of the diode.

The red lead is positive and the black lead is negative.

If overrange (1) is displayed with both lead connections, the junction is open.



### **(E) Transistor $h_{FE}$ Measurement**

1. The transistor must be out of circuit. Set the rotary selector knob to the  $h_{FE}$  position.
2. Turn the meter on by pressing the power switch.
3. Plug the emitter, base and collector leads of the transistor into the correct holes in either the NPN or the PNP transistor test socket, whichever is appropriate for the transistor you are checking.
4. Read the  $h_{FE}$  (beta or DC current gain) on the display.

### **(F) Capacitance Measurement**

1. Connect red test lead to the “V $\Omega$ CAP” input jack and the black one to “COM”.
2. Turn the meter on by pressing the power switch.
3. Set the rotary selector knob to the “FARAD” position.
4. Set the rotary selector knob to the desired capacitance position.
5. Short the leads of the capacitor to be tested together to insure that there is no charge on the capacitor.
6. Connect the leads to the capacitor and read the capacitance value on the digital display.

---

## **SHUNT WIRE CALIBRATION**

To calibrate the shunt wire, you will need a 5 amp current source such as a 5V power supply and a 1 ohm, 25 watt resistor. If a 5 amp source is not available, you can use a lower current (2 amps). If no supply is available, it is not important to do this test. Set the range switch to the 20A position and connect the test leads.

If the meter reads higher than 5A, resolder the shunt wire so that there is less wire between the two mounting holes.

If the meter reads low, resolder the shunt wire so that there is more wire between the two mounting holes.

---

## **4. OPERATION MAINTENANCE**

### **4-1 Battery and Fuse Replacement**

#### **CAUTION**

BEFORE ATTEMPTING BATTERY REMOVAL OR REPLACEMENT, DISCONNECT THE TEST LEADS FROM ANY ENERGIZED CIRCUITS TO AVOID SHOCK HAZARD.

The fuse rarely needs replacement and blow almost always as a result of operator error. To replace the battery and fuse (200mA/250V), remove the two screws in the bottom of the case. Simply remove the old battery or fuse and replace with a new one.

## 5. SAFETY SYMBOLS



This marking adjacent to another marking or a terminal operating device indicates that the operator must refer to an explanation in the operating instructions to avoid damage to the equipment and/or to avoid personal injury.



This WARNING sign denotes a hazard. It calls attention to a procedure, practice or the like, which if not correctly performed or adhered to, could result in personal injury.



This CAUTION sign denotes a hazard. It calls attention to a procedure, practice or the like, which if not correctly adhered to, could result in damage to or destruction of part or all of the instrument.



This marking advises the user that the terminal(s) so marked must not be connected to a circuit point at which the voltage, with respect to earth ground, exceeds (in this case) 500 volts.



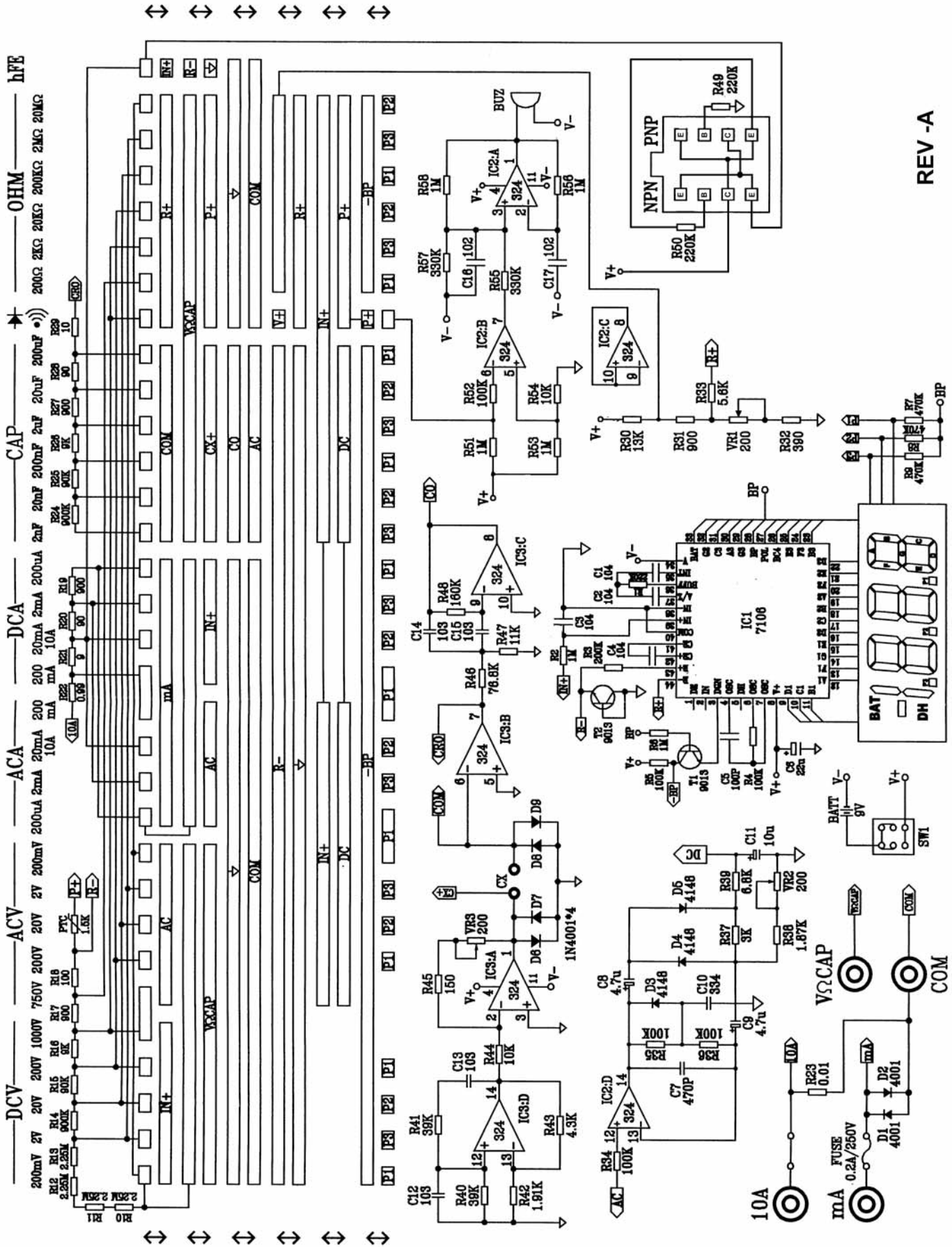
This symbol adjacent to one or more terminals identifies them as being associated with ranges that may in normal use be subjected to particularly hazardous voltages. For maximum safety, the instrument and its test leads should not be handled when these terminals are energized.

## QUIZ

- The function of the A/D converter is to . . .
  - A. convert digital to analog.
  - B. divide analog signal by 2.
  - C. convert analog to digital.
  - D. convert AC to DC.
- What type of divider network is used for voltage measurements?
  - A. Divide by 20
  - B. Capacitance
  - C. Divide by 5
  - D. Resistor
- When the AC voltage is measured, it is first . . .
  - A. divided down by 2.
  - B. converted to DC.
  - C. coupled to a halfwave rectifier.
  - D. low voltage.
- When measuring current, the shunt resistors convert the current to . . .
  - A. +0.190 to -0.190.
  - B. -1.199 to +1.199.
  - C. -0.099 to +0.099.
  - D. -199 to +0.199.
- Which IC drives the LCD?
  - A. 358
  - B. LM324
  - C. 7106
  - D. 1N5232
- Resistance measurements are made by . . .
  - A. comparing voltage drops in the unknown resistor and a reference resistor.
  - B. measuring the current in the unknown resistor.
  - C. measuring the current in the reference resistor.
  - D. equalizing the voltage drop in the unknown and reference resistor.
- Measurement cycles performed by the A/D converter can be divided into what types of time periods?
  - A. Long, short
  - B. Auto zero, integrate, read
  - C. Zero, read, interphase
  - D. Autozero, read, cycle phase
- A resistor with band colors green-black-green-brown-green is what value?
  - A.  $50.5\text{k}\Omega \pm 5\%$
  - B.  $5.15\text{k}\Omega \pm 10\%$
  - C.  $5.05\text{k}\Omega \pm .5\%$
  - D.  $5.05\text{k}\Omega \pm 1\%$
- When checking a transistor, the selector knob should be in the . . .
  - A. farad position.
  - B. ohm position.
  - C. diode position.
  - D. hFE position.
- Where do the leads need to be on the meter when measuring 450mA?
  - A. 10A, COM
  - B.  $V\Omega\text{CAP}$ , COM
  - C.  $\mu\text{A}/\text{mA}$ , 10A
  - D.  $\mu\text{A}/\text{mA}$ , COM

Answers: 1. C, 2. D, 3. B, 4. B, 5. C, 6. A, 7. B, 8. C, 9. D, 10. A

# SCHEMATIC DIAGRAM



REV-A

**Elenco® Electronics, Inc.**

150 Carpenter Avenue

Wheeling, IL 60090

(847) 541-3800

Website: [www.elenco.com](http://www.elenco.com)

e-mail: [elenco@elenco.com](mailto:elenco@elenco.com)