

Cuisinart®

INSTRUCTION
BOOKLET

Recipe
Booklet



12-Cup Cuisinart Elite Collection™ Food Processor

FP-12C Series

For your safety and continued enjoyment of this product,
always read the instruction book carefully before using.

RECOMMENDED MAXIMUM WORK BOWL CAPACITIES

FOOD	CAPACITY 12-Cup (3 L) WORKBOWL	CAPACITY 4-cup (1 L) WORKBOWL
Sliced or shredded fruit, vegetables or cheese	12 cups (3 L)	N/A
Chopped fruit, vegetables or cheese	9 cups (2.25 L)	3 cups (750 ml)
Puréed fruit, vegetables or cheese	10 cups (2.50 L) cooked 6 cups (1.5 L) puréed	3 cups (750 ml) cooked 1½ cups (375 ml) puréed
Chopped or puréed meat, fish, seafood	2 pounds (900 g)	½ pound (226 g)
Thin liquid* (e.g. dressing, soups, etc.)	8 cups (2 L)	3 cups (750 ml)
Cake batter	One 9-inch (23 cm) cheesecake Two 8-inch (20 cm) homemade layers (1 box 18.5 oz. cake mix)	N/A
Cookie dough	6 dozen (based on average chocolate chip cookie recipe)	N/A
White bread dough	5 cups (1.25 L) flour	N/A
Whole wheat bread dough	3 cups (750 ml) flour	N/A
Nuts for nut butter	5 cups (1.25 L)	1½ cups (375 ml)

* When processing egg-based liquids, like a custard base for quiche, reduce maximum capacity by 2 cups (500 ml).

IMPORTANT UNPACKING INSTRUCTIONS

This package contains a Cuisinart Elite Collection™ 12-Cup Food Processor and the accessories for it:

12- and 4-cup work bowls, work bowl cover, large and small metal chopping/mixing blades, dough blade, adjustable slicing disc, reversible shredding disc, stem adapter, large and small pushers, spatula, cleaning tool and instruction/recipe book.

CAUTION: THE CUTTING TOOLS HAVE VERY SHARP EDGES. To avoid injury when unpacking the parts, please follow these instructions.

- Place the box on a low table or on the floor next to the kitchen counter or table where you intend to keep the food processor. Be sure the box is right side up.
- Open top flaps and remove the cardboard insert. You will see a rectangular block of plastic foam that holds the processor parts, each fitted into a cavity in the foam. Remove the instructional material and cleaning tool first.
The spatula and stem adapter (A) are in cavities at one short side of the foam block. Remove them next.
The bowl cover (B) is in a cavity at the centre of the foam block. Grasp the edge of the bowl cover and lift it straight up to remove it. The adjustable slicing disc (C) and reversible shredding disc (D) are on either long side of the foam block. Slide them out of their grooves **WITH GREAT CARE. THE BLADES ARE VERY SHARP.**
Remove the large (E) and small (F) metal chopping/mixing blades from the foam block. **CAREFULLY REMOVE THEM BY GRASPING THE CENTRE WHITE HUB AND LIFTING THEM STRAIGHT UP. NEVER TOUCH THE BLADES, AS THEY ARE RAZOR SHARP.**
- Lift out the top foam block.
- The 12- and 4-cup work bowls (G), large/small pushers (H) and dough blade (I) are in the middle foam block. Remove them next.
- Lift out the middle foam block.
- The housing base (K) is at the bottom of the box. Assemble the work bowls on the

base by placing them over the shaft and using the handle to turn the work bowl counterclockwise to lock it, then remove the housing base (K) from the bottom of the box.

- Place the food processor on the countertop or table. Read the Assembly and Operating Instructions thoroughly before using the machine.
- Save the shipping cartons and plastic foam blocks. You will find them very useful if you need to repack the processor for moving or other shipment.

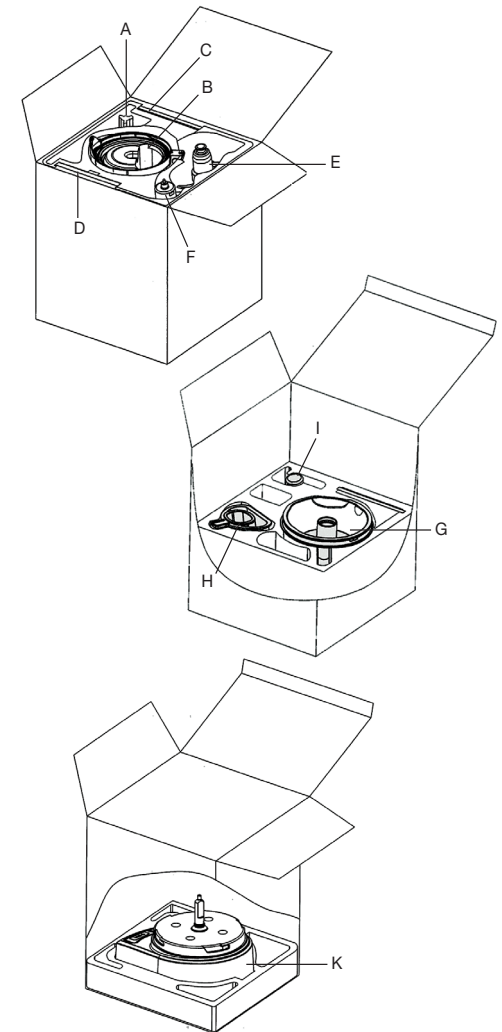

IMPORTANT SAFEGUARDS

Always follow these safety precautions when using this appliance.

Getting Ready

1. Read all instructions.
2. **Blades and discs are sharp.** Handle them carefully.
3. **Always unplug from outlet when not in use, before putting on or taking off parts, before removing food and before cleaning. To unplug, grasp plug and pull from electrical outlet. Never pull cord.**
4. Do not use outdoors.
5. Do not let cord hang over edge of table or counter, or touch hot surfaces.
6. Do not operate any appliance with damaged cord or plug, or after appliance has been dropped or damaged in any way. Return the appliance to the Customer Service Centre (see Warranty for details) for examination, repair or mechanical or electrical adjustment.
7. Do not operate your appliance in an appliance garage or under a wall cabinet. When storing in an appliance garage always unplug the unit from the electrical outlet. Not doing so could create a risk of fire, especially if the appliance touches the walls of the garage or the door touches the unit as it closes.

Operation

1. Keep hands as well as spatulas and other utensils away from moving blades or discs while processing food, to prevent the possibility of severe personal injury or damage to food processor. A plastic scraper may be used, but only when the food processor motor is stopped.
2. Avoid contact with moving parts. Never push food down by hand when slicing or shredding. Always use pusher.
3. Make sure motor has completely stopped before removing cover. (If machine does not stop within 4 seconds after you remove the pusher assembly, call 1-800-472-7606 for assistance. Do not use the machine.)
4. Never store any blade or disc on motor shaft. To reduce the risk of injury, no blade or disc

should be placed on the shaft except when the bowl is properly locked in place and the processor is in use. Store blades and discs, as you would sharp knives, out of reach of children.

5. Be sure cover and feed tube are securely locked in place before operating food processor.
6. Never try to override or tamper with cover interlock mechanism.

Cleaning

To protect against risk of electrical shock, do not put base in water or other liquid.

General

1. This appliance should not be used by or near children or individuals with certain disabilities.
2. Do not operate this, or any other motor-driven appliance, while under the influence of alcohol or other substances that affect your reaction time or perception.
3. This food processor is CUL listed for household use. Use it only for food preparation as described in the accompanying recipe and instruction book. Do not use this appliance outside of its intended use.
4. The use of attachments not recommended or sold by Cuisinart may cause fire, electrical shock or personal injury, or damage to your food processor.
5. To avoid possible malfunction of work bowl switch, never store processor with pusher assembly in locked position.
6. Maximum rating of 6.5 amperes is based on attachment that draws greatest current. Other recommended attachments may draw significantly less current.

NOTICE: If your food processor has a plastic case, it has a polarized plug (one blade is wider than the other). As a safety feature, this plug will fit in a polarized outlet only one way. If the plug does not fit fully in the outlet, reverse the plug. If it still does not fit, contact a qualified electrician. Do not attempt to defeat this safety feature.

SAVE THESE INSTRUCTIONS FOR HOUSEHOLD USE ONLY

WARNING: RISK OF FIRE OR ELECTRIC SHOCK



The lightning flash with arrowhead symbol within an equilateral triangle is intended to alert the user to the presence of un-insulated dangerous voltage within the product's enclosure that may be of sufficient magnitude to constitute a risk of fire or electric shock to persons.



The exclamation point within an equilateral triangle is intended to alert the user to the presence of important operating and maintenance (servicing) instructions in the literature accompanying the appliance.

SPECIAL CORD SET INSTRUCTIONS

NOTICE

If you have a die-cast metal unit, for your protection, it is equipped with a 3-conductor cord set that has a molded 3-prong grounding-type plug, and should be used in combination with a properly connected grounding-type outlet as shown in Figure A.

If a grounding-type outlet is not available, an adapter, shown in Figure B, may be obtained so that a 2-slot wall outlet can be used with a 3-prong plug. As shown in Figure C, the adapter must be grounded by attaching its grounding lug under the screw of the outlet cover plate.

NOTE: Do not remove the grounding prong.

CAUTION: Before using an adapter, it must be determined that the outlet cover plate screw is properly grounded. If in doubt, consult a licensed electrician. Never use an adapter unless you are sure it is properly grounded.

Note: Use of an adapter is not permitted in Canada.

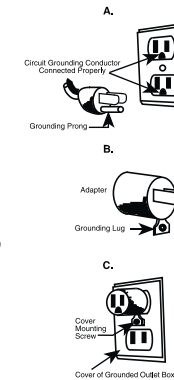

CONTENTS

Important Unpacking Instructions.....	3
Important Safeguards.....	4
Introduction	5
Features and Benefits	6
Assembly Instructions, Diagram	8
Machine Controls	9
Work Bowls	9
Machine Functions	9
User Guide and Capacity Chart.....	11
Cleaning, Storage and Maintenance.....	15
For Your Safety.....	15
Technical Data.....	15
Troubleshooting	16
Warranty Information.....	18

INTRODUCTION

The food processor that re-invented the art of food preparation once again leads the way in innovation! Congratulations on your purchase of the Cuisinart Elite Collection™ 12-Cup (3 L) Food Processor – the next generation in culinary excellence.

Superbly designed for high performance and ease of use, the Cuisinart Elite Collection™ 12-Cup (3 L) has the power, capacity, versatility, precision, and accessories to handle any task. From the two nested and sealed bowls to the adjustable slicing disc and reversible shredding disc, these incredible features create multiple food processors in one!

All of these pioneering, creative elements come together with Cuisinart's leading reputation to give you the Elite Collection™ 12-Cup (3 L) Food Processor – the finest food prep appliance for today's modern kitchen.

WARNING

RISK OF FIRE OR ELECTRIC SHOCK
DO NOT OPEN

WARNING: TO REDUCE THE RISK OF FIRE OR ELECTRIC SHOCK,

DO NOT REMOVE COVER (OR BACK)

NO USER-SERVICEABLE PARTS INSIDE

REPAIR SHOULD BE DONE BY AUTHORIZED SERVICE PERSONNEL ONLY

FEATURES AND BENEFITS

1. Housing Base and Motor

With a vertically projecting motor shaft, this powerful base will process through a variety of recipes with 1000 watts of peak power.

2. Touchpad Control Panel

These easy to clean, electronically controlled buttons, feature On, Off and Pulse options, for every food processing function. The contemporary, blue LED light will indicate when the unit is powered on.

3. Work Bowls

Designed with maximum versatility, the work bowl should be selected based on task appropriateness.

These nested bowls feature SealTight™ technology, which maximizes each bowl's processing capacity, ensures safe handling, and keeps all the ingredients contained in the bowl you're using! The bowls also include a locking feature to prevent them from coming out of position when pouring, and finger recesses (a) for user-friendliness.

The large and small work bowls are all made of durable material with convenient measurement markings (b) and pour spouts (c).

4. Work Bowl Cover with Feed Tube

Work bowl cover with SealTight™ Advantage feature allows for maximum bowl capacity during processing and pouring. To remove the work bowl cover, push in the release buttons (a) on either side of the handle interlock (b).

The Supreme® Wide-Mouth feed tube (c) accommodates larger ingredients and saves pre-cutting time.

5. Pusher Assembly

Secured with a snap-fit, the small pusher (a) inside the large pusher (b) allows you to accommodate ingredients of all sizes. The large pusher lock (c), located on the handle, enables it to be pulled out to lock and pushed in to unlock – this feature should be used when processing heavy loads.

6. Small Chopping/Mixing Blade

This small stainless steel blade will chop or mix anything in your small work bowl and also features the BladeLock System.

7. Large Chopping/Mixing Blade

Stainless steel in construction, this heavy-duty blade will process a variety of food in your large work bowl. The BladeLock System enables the blade to stay in place to prevent leaking, while providing optimal pouring.

8. Dough Blade

Designed for superb results, this blade will knead through all types of dough. The dough blade can be used only in the large bowl.

9. Adjustable Slicing Disc

The versatile 6-in-1 disc allows for thin to thick slices with 1 to 6mm indicators. This disc may be used only in the large bowl.

10. Reversible Shredding Disc

Provides the option of either fine or medium shredding for optimal results. This disc may be used only in the large bowl.

11. Stem Adapter

This user-friendly tool easily attaches to either disc or small chopping/mixing blade to engage the motor shaft.

12. Spatula

Uniquely designed for use with either work bowl.

13. Cord Storage (not shown)

Keeps countertops safe and clean by conveniently wrapping excess cord under the unit.

14. Cleaning tool

This tool is designed to aid in the cleaning of the underside of the work bowl cover, by using either the flat side or the brush side.

15. BPA free

All materials that come in contact with food are BPA free.

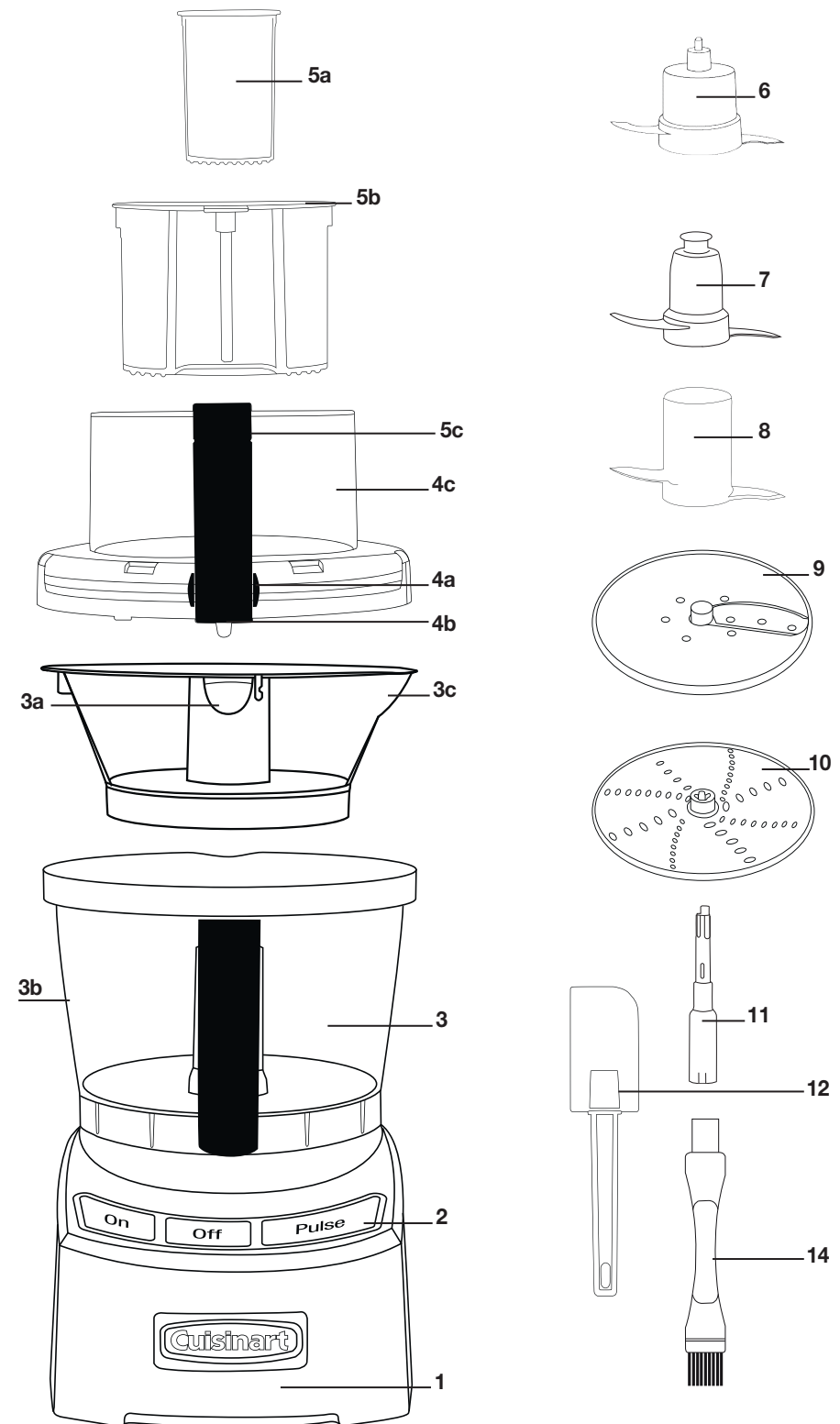

ASSEMBLY INSTRUCTIONS

Before first use

Before using your Cuisinart Elite Collection™ 12-Cup (3 L) Food Processor for the first time, wash the work bowls, work bowl cover, pusher assembly, blades, discs, and spatula (see Cleaning Instructions on page 15).

1. Place the food processor base on a dry, level countertop with the controls facing toward you. Do not plug the unit in until it is fully assembled.
2. With the large bowl on the base, use the handle to turn the work bowl counterclockwise to lock it onto the housing base.

To use the small bowl, place your thumbs in the finger recesses and align the pour spout facing opposite the handle.

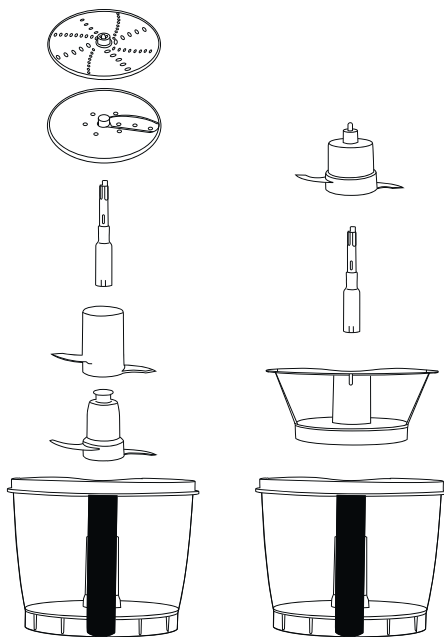

Blade Operation

The BladeLock feature is designed to keep the blade in place during processing, pouring, lifting, and handling tasks – but is not permanently attached. **Handle with care.**

Note: The chopping/mixing blades should not be removed with liquid contents above the hub of the blade in the bowls, as this will defeat the SealTight™ system.

Large Blade Operation

3. With your large work bowl assembled on the base, grasp the large chopping/mixing blade by its hub, align it over the centre of the bowl, twist into position and push down firmly to lock.

Dough Blade Operation

4. For use with the large bowl. Carefully lift and place the dough blade over the centre hub of the work bowl by lining up the markings and sliding the blade down.

Small Blade Operation

5. With both work bowls assembled on the base, position the stem adapter over the centre of the bowls, twist into position and push down to lock. Grasp the small chopping/mixing blade by its hub, place it over the stem adapter, twist into position and push down firmly to lock.

Disc Operation

6. When using your large bowl, position the stem adapter over the centre of the bowl, twist into position and push down to lock. If using the adjustable slicing disc, use the rotating hub and indicator markings to select slicing thickness. Using the plastic hub, align and insert the disc over the stem adapter.

If using the reversible shredding disc, determine whether the fine or medium side will be used and use the plastic hub to twist into position on the stem adapter. The plastic hub may be used for removal of this disc.

Cover Operation

7. Place the work bowl cover onto the work bowl by positioning it directly over the bowls, and push down on the front and back to lock into place.

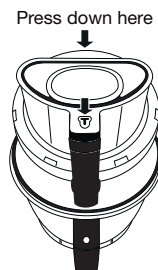

To remove the cover, push in both sides of the release button (located on the cover interlock) and lift up to remove.

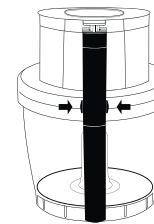

Note: The work bowl cover fits, locks and seals on the large bowl with any nested bowl combination. The work bowl cover will become easier to engage with repeated use.

8. Align pusher assembly and activating rod with the feed tube opening on the work bowl cover and slide it down completely.
9. Plug the food processor into a proper electrical outlet. It is now ready for use.

Note: The bowl, lid and pushers must be securely in place for the unit to operate.

MACHINE CONTROLS

On Button

The On control is a continuous button that allows the machine to run until Off is selected.

1. Properly assemble and engage the machine.
2. Add ingredients to the work bowl, either through the feed tube or directly into the bowl.
3. Press the On button. The blue LED light will illuminate and the motor will start.
4. Press the Off button when finished.

PULSE Button

The Pulse control is a momentary button that allows the machine to run only while it is being pressed. This capability provides more accurate control of the duration and frequency of processing.

1. With the machine properly assembled and engaged, and ingredients in the work bowl, press the Pulse button repeatedly as needed. The blue LED On light will be illuminated upon activation.

WORK BOWLS

Two nested work bowls are provided for a very versatile processing experience. We recommend using the work bowls in a manner that will optimize efficiency. For example, if your recipe requires using both bowls, begin with the small bowl to minimize cleaning. This way the small bowl can serve as a prep bowl to reserve chopped ingredients for a recipe.

Note that the bowls lock into place to pour while nested. The convenient finger recesses can be used to remove the small bowl with ingredients, or the bowl can remain nested during pouring or food removal.

Chopping certain foods may scratch or cloud the work bowl, this will not affect the functionality of your work bowl.

MACHINE FUNCTIONS

Chopping (using the Chopping Blade)

- For raw ingredients: peel, core and/or remove seeds and pits. Food should be cut into even, ½ to 1-inch (1.3-2.5 cm) pieces. Foods cut into same size pieces produce the most even results.
- Pulse food in 1-second increments to chop. For the finest chop, either hold the pulse down or press ON to run the machine continuously. Watch ingredients closely to achieve desired consistency and scrape the work bowl as necessary.

Puréeing (using the Chopping Blade)

- To purée fresh fruits or cooked fruits/vegetables: ingredients should be cut into 1-inch (2.5 cm) pieces; a smooth purée is achieved easiest when all the pieces are equal in size. Pulse to initially chop and then process ON until food is puréed; scrape the work bowl as necessary. Do not use this method to purée cooked white potatoes. (see Mashed Potato recipe on page 35.)
- To purée solids for a soup or sauce: strain the solids from the liquid and process the solids alone. Add cooking liquid and process as needed.

Kneading (using the Dough Blade or the Metal Chopping Blade)

- The dough blade is engineered to knead through yeast dough, while the metal chopping blade is ideal for pastry doughs.
- The pusher lock is recommended to be in the locked position when kneading dough to avoid it from moving around – some vibration is still normal.
- Dough kneading should be done in the large bowl only.

Slicing (using the Adjustable Slicing Disc)

- Always pack food in the feed tube evenly to slice. For smaller amounts of food, use the smaller feed tube. For cheese slicing, always use the large feed tube. The food will dictate the amount of pressure: Use light pressure for soft foods, medium pressure for medium foods, and firm pressure for harder foods. Always process with even pressure.
- For julienne or matchstick cuts: Place food horizontally in the feed tube and process with even pressure to create long, plank-like slices. Replace stack of slices in feed tube vertically and process again using even pressure.
- For round fruits or vegetables: Remove a thick slice on the bottom of the food so that it sits upright in the feed tube. If food does not fit in the feed tube, cut in half or quarters to fit. Process with even pressure.
- For small ingredients, like mushrooms, radishes or strawberries: Trim the ends so the food sits upright in the feed tube. Take advantage of the smaller feed tube if appropriate.
- When slicing cheese, be sure that the cheese is well chilled before slicing.

Shredding (using the Reversible Shredding Disc)

- Always pack food in the feed tube evenly to shred. For smaller amounts of food, use the smaller feed tube. For cheese shredding, always use the large feed tube. The food will dictate the amount of pressure: Use light pressure for soft foods, medium pressure for medium foods and firm pressure for harder foods. Always process with even pressure.
- To shred leafy vegetables like lettuce or spinach: Roll leaves together and stand up in feed tube. Process with even pressure.
- When shredding cheese, be sure that the cheese is well chilled before shredding.

USER GUIDE & CAPACITY CHART

FOOD	TOOL	PROCESS	YIELD	DIRECTIONS
FRUITS Apples	Metal Blade	Chop	1 pound = 3 cups (750 ml)	Cut into 1-inch (2.5 cm) pieces; pulse to chop – process for fine chop.
	Metal Blade	Purée	1 pound = 3 cups (750 ml)	Process to purée cooked and peeled apples for applesauce.
	Slicing Disc	Slice	1 apple = ¾ cup (175 ml)	Medium pressure
	Shredding Disc	Shred	1 apple = ¾ cup (175 ml)	Medium pressure
Avocados	Metal Blade	Chop	1 medium = 1 cup (250 ml)	Cut into 1-inch (2.5 cm) pieces; pulse to chop.
	Metal Blade	Purée	1 medium = 1 cup (250 ml)	Cut into 1-inch (2.5 cm) pieces; process to purée.
Bananas	Metal Blade	Purée	3 medium = 1 cup (250 ml)	Process to purée ripe bananas.
	Slicing Disc	Slice	1 pound = 2 cups (500 ml)	Light pressure for firm bananas.
Berries	Metal Blade	Purée	1 pint fresh = 2 cups (500 ml); 10 ounce-bag frozen = 1½ cups (375 ml)	Process until puréed. Strain to remove seeds. Thaw frozen berries before processing.
	Slicing Disc	Slice	1 pint = 2 cups (500 ml)	Strawberries: remove stems; stack berries on their side. Medium pressure.
Coconuts	Metal Blade	Chop	1 medium = 4 cups (1 L)	Cut flesh into 1-inch (2.5 cm) pieces; pulse to chop.
	Shredding Disc	Shred	1 medium = 4 cups (1 L)	Process to finely chop. Cut flesh to fit feed tube, medium pressure.
Kiwis	Slicing Disc	Slice	2 kiwis = ¾ cup (175 ml)	Chill and peel; light pressure.
Mangoes	Metal Blade	Chop	1 medium = ¾ to 1 cup (175 ml-250 ml)	Cut into 1-inch (2.5 cm) pieces; pulse to chop.
	Metal Blade	Purée	1 medium = ¾ to 1 cup (175 ml-250 ml)	Cut into 1-inch (2.5 cm) pieces; process to purée.
Peaches/ Nectarines	Metal Blade	Chop	1 lb = 2 to 2½ cups (500-625 ml)	Cut into 1-inch (2.5 cm) pieces; pulse to chop.
	Metal Blade	Purée	1 lb = 2 to 2½ cups (500-625 ml)	Cut into 1-inch (2.5 cm) pieces; peel and process to purée.
	Slicing Disc	Slice	1 lb = 2 to 2½ cups (500-625 ml)	Remove pit, light pressure.
Citrus Fruits; Lemons, Limes & Oranges	Metal Blade	Chop	For medium fruit: 1 lemon = 2 to 3 teaspoons (10-15 ml) zest; 1 lime = 1 tsp (5 ml) zest;	Zest: use vegetable peeler to remove rind; process. For the finest chopped zest, add small amount of sugar to chop with zest
	Slicing Disc	Slice	1 orange = 1½ tablespoons (25 ml) zest	Trim ends; place upright in feed tube. Medium pressure.
Dried (sticky) Fruits	Metal Blade	Chop	1 pound = 2½ cups (625 ml)	Chill fruit. Add some flour from recipe to work bowl. Process using short pulses until desired consistency.
VEGETABLES Beans - Green, Wax	Metal Blade	Purée	1 cup (250 ml) = ½ cup (125 ml) purée	Process to purée cooked beans.
Broccoli/ Cauliflower	Slicing Disc	Slice	1 pound = 3 cups (750 ml)	"French-cut": trim beans; stack in feed tube horizontally. Light pressure.
	Metal Blade	Chop	1 pound raw = 2 cups (500 ml)	Cut into 1-inch (2.5 cm) pieces; pulse to chop.
	Metal Blade	Purée	1 pound cooked = 1 cup (250 ml)	Cut into 1-inch (2.5 cm) pieces; process to purée.
	Slicing Disc	Slice	Broccoli stems only	Peel and trim stems. Medium pressure.
Cabbage	Shredding Disc	Shred	Broccoli stems only	Peel and trim stems. Medium pressure.
	Metal Blade	Chop	2 pounds = 8 cups (2 L)	Cut into 1-inch (2.5 cm) pieces; pulse to chop to desired consistency.
	Slicing Disc	Slice	2 pounds = 8 cups (2 L)	Cut in wedges to fit feed tube; remove centre core. Light to no pressure. Use slicing disc for coleslaw.
Carrots	Shredding Disc	Shred	2 pounds = 8 cups (2 L)	Use shredding disc for extra-fine needs.
	Metal Blade	Chop	1 pound (6 med) = 3 cups (750 ml)	Cut into 1-inch (2.5 cm) pieces; pulse to chop to desired consistency.
	Metal Blade	Purée	2 med cooked = ½ cup (125 ml) purée	Process to purée.
	Slicing Disc	Slice	1 pound (6 med) = 3 cups (750 ml)	Small rounds: trim; place upright in feed tube. Long slices: trim; place horizontally in feed tube. Medium to firm pressure.
Shredding Disc	Shred	1 pound (6 med) = 2½ cups (625 ml)	Small shreds: trim; place upright in feed tube. Long shreds: trim; place horizontally in feed tube. Medium to firm pressure.	

FOOD	TOOL		YIELD	DIRECTIONS
Celery	Metal Blade	Chop	2 medium stalks = ½ cup (125 ml)	Cut into 1-inch (2.5 cm) pieces; pulse to chop to desired consistency.
	Slicing Disc	Slice	2 medium stalks = ½ cup (125 ml)	Trim; place upright in feed tube. Medium pressure.
Cucumbers	Metal Blade	Chop	1 medium = 1½ cups (375 ml)	Cut into 1-inch (2.5 cm) pieces; pulse to chop.
	Slicing Disc	Slice	1 medium = 1½ cups (375 ml)	Rounds: trim; place upright in feed tube. Medium pressure. Long slices: trim; place horizontally in feed tube. Medium pressure.
	Shredding Disc	Shred	1 medium = 1½ cups (375 ml)	Shreds: trim; place upright in feed tube. Medium pressure. Long shreds: trim; place horizontally in feed tube. Medium pressure.
Garlic	Metal Blade	Chop	1 head = 12 to 16 cloves; 1 medium clove = ½ teaspoon (2 ml)	Peel; with machine running, drop cloves through feed tube to finely chop.
Ginger	Metal Blade	Chop	1-inch (2.5 cm) pieces = 1 tablespoon (15 ml)	Peel; cut into ½-inch (1.25 cm) pieces. With machine running, drop through feed tube to finely chop.
	Slicing Disc	Slice	4 ounces = ½ cup (125 ml)	Peel; place upright in feed tube. Medium pressure.
	Shredding Disc	Shred	4 ounces = ½ cup (125 ml)	Peel; place upright in feed tube. Medium pressure.
Herbs - Fresh	Metal Blade	Chop	1 cup (250 ml) loosely packed = ½ cup (75 ml)	Herbs, work bowl and blade should be clean and completely dry. Pulse to roughly chop. Process to finely chop. Keep up to 10 days in airtight bag in refrigerator.
Jalapeño	Metal Blade	Chop	1 medium pepper = 3 tablespoons (45 ml)	Remove seeds and stem. With machine running, drop halved pepper through feed tube to chop.
	Slicing Disc	Shred	1 medium pepper = ¼ cup (50 ml)	Remove seeds and stem. Cut stem end flat to slice into rings; medium pressure. Place upright in feed tube for narrow slices, horizontally for longer slices.
Leeks	Metal Blade	Chop	1 pound = 2 cups (500 ml)	Clean leeks; trim, discard dark green parts. Cut into 1-inch (2.5 cm) pieces; pulse to chop.
	Slicing Disc	Slice	1 pound = 2 cups (500 ml)	Clean leeks as above. Place upright in feed tube; medium pressure. Long slices: trim; place lengthwise in feed tube. Medium pressure.
Mushrooms	Metal Blade	Chop	1 pound = 6 cups (1.5 L)	Cut into even pieces; pulse to chop.
	Slicing Disc	Slice	1 pound = 5 cups (1.25 L)	Pack feed tube. Light pressure.
	Shredding Disc	Shred	1 pound = 5 cups (1.25 L)	Pack feed tube. Light pressure.
Onions	Metal Blade	Chop	1 pound = 4½ to 5 cups (1.1-1.25 L)	Cut into 1-inch (2.5 cm) pieces; pulse to chop.
	Slicing Disc	Slice	1 medium = ¾ to 1 cup (175-250 ml)	Trim; place in feed tube. Medium pressure.
Peppers - Bell	Metal Blade	Chop	1 pound = 4½ to 5 cups (1.25 L)	Cut into 1-inch (2.5 cm) pieces; pulse to chop.
	Slicing Disc	Slice	1 pound = 3 cups (750 ml)	Remove seeds and stem. Cut stem end flat to slice into rings; medium pressure. Halve or quarter and place upright in feed tube for narrow slices, horizontally for longer slices.
Pickles	Metal Blade	Chop	1 medium = ¾ cup (175 ml)	Cut into 1-inch (2.5 cm) pieces; pulse to chop.
	Slicing Disc	Slice	1 medium = ¾ cup (175 ml)	Place upright in feed tube for rounds; horizontally for longer slices. Medium pressure.
Potatoes	Metal Blade	Chop	1 pound = 3½ to 4 cups (875 ml-1 L)	Raw potatoes: cut into 1-inch (2.5 cm) pieces; pulse to chop.
	Metal Blade	Purée	1 cup (250 ml) cooked (1-inch (2.5 cm) pieces) = ½ cup (125 ml)	Sweet potatoes/yams: cut into 1-inch (2.5 cm) pieces; pulse to chop.
	Slicing Disc	Slice	1 pound = 3½ to 4 cups (875 ml-1 L)	Trim end flat; cut to fit into feed tube. Light to medium pressure for white potatoes; firm pressure for sweet potatoes/yams; light pressure for partially cooked potatoes.
	Shredding Disc	Shred	1 pound = 3½ to 4 cups (875 ml-1 L)	Trim end flat; cut to fit into feed tube. Light to medium pressure for white potatoes. Note: keep sliced or shredded raw potatoes in cold water to avoid discoloration; dry well before using. Mashed potatoes: process cooked white potatoes through medium shredding disc to avoid a gluey consistency.

FOOD	TOOL		YIELD	DIRECTIONS
Radishes	Metal Blade	Chop	½ pound = 1½ cups (375 ml)	Cut into 1-inch (2.5 cm) pieces; pulse to chop. Process to finely chop.
	Slicing Disc	Slice	½ pound = 1½ cups (375 ml)	Trim ends; firm pressure.
	Shredding Disc	Shred	½ pound = 1½ cups (375 ml)	Trim ends; firm pressure.
Scallions	Metal Blade	Chop	1 to 2 = ¼ cup (50 ml)	Cut into 1-inch (2.5 cm) pieces; pulse to chop.
	Slicing Disc	Slice	1 to 2 = ¼ cup (50 ml)	Trim, discard dark green parts, place upright in feed tube. Light to medium pressure. Long slices: trim; place lengthwise in feed tube. Medium pressure.
Spinach	Metal Blade	Chop	1 pound raw = 10 cups (2.50 L) raw	Pulse to chop.
	Metal Blade	Purée	1 pound raw = 1½ cups (375 ml) cooked	Process to purée.
	Slicing Disc	Slice	1 pound raw = 10 cups (2.50 L) raw	Roll leaves together and place upright in feed tube; medium pressure.
Zucchini/Summer Squash	Metal Blade	Chop	1 pound = 3 cups (750 ml)	Cut into 1-inch (2.5 cm) pieces; pulse to chop.
	Slicing Disc	Slice	1 pound = 3 cups (750 ml)	Rounds: trim; place upright in feed tube. Long slices: trim; place horizontally in feed tube. Medium pressure.
	Shredding Disc	Shred	1 pound = 3 cups (750 ml)	Shredding: trim; place upright in feed tube. Long shreds: trim and place horizontally in feed tube. Medium pressure.
CHEESES Soft Cheeses; Ricotta, Cream, Cottage, Brie, Blue, Fontina Mozzarella, Bel Paese	Metal Blade	Purée	½ pound = 1 cup (250 ml)	Cut into 1-inch (2.5 cm) pieces. Process soft cheeses until smooth.
	Metal Blade	Chop	¼ pound = 1 cup (250 ml)	Cut into 1-inch (2.5 cm) pieces; pulse to chop.
	Shredding Disc	Med. Shred	¼ pound = 1 cup (250 ml)	Chill well; medium pressure. Mozzarella should be frozen for 25 to 30 minutes before shredding.
	Shredding Disc	Fine Shred	¼ pound = 1 cup (250 ml)	
Firm Cheeses; Cheddar, Swiss, Edam & Gouda	Metal Blade	Chop	¼ pound = 1 cup (250 ml)	Cut into ½- to 1-inch (1.25-2.5 cm) pieces; temperature not critical.
	Slicing Disc	Slice	¼ pound = 1 cup (250 ml)	Chill well; light to medium pressure.
	Shredding Disc	Med. Shred	¼ pound = 1 cup (250 ml)	Chill well; medium pressure.
	Shredding Disc	Fine Shred	¼ pound = 1 cup (250 ml)	Chill well; light pressure.
Hard Cheeses; Parmesan & Romano	Metal Blade	Chop	¾ pound = 3 cups (750 ml)	Cut into ½- to 1-inch (1.25-2.5 cm) pieces; temperature not critical. *Never process cheese that cannot be pierced with the tip of a sharp knife.
	Shredding Disc	Med. Shred	¼ pound = 1 cup (250 ml)	Cheese should be room temperature.
	Shredding Disc	Fine Shred	¼ pound = 1 cup (250 ml)	Cheese should be room temperature.
ADDITIONAL FOODS Baby Food	Metal Blade	Purée		As with all fruit and cooked vegetable purées, cut ingredients into 1-inch (2.5 cm) pieces. Steam cooked ingredients until completely soft. Pulse to chop, then process until completely smooth. To ensure there are no lumps, press mixture through a fine mesh strainer. Keeps well frozen in ice cube trays for individual 1-ounce (30 ml) portions.
Butter	Metal Blade	Chop	¼ pound (1 stick) = ½ cup (125 ml)	Butter should be room temperature and cut into tablespoon-size pieces. Process, scraping bowl as necessary. Compound butters: process flavouring ingredients before adding butter. Pastry: cut butter into small cubes; freeze before using.
	Slicing Disc	Slice	¼ pound (1 stick) = ½ cup (125 ml)	Butter should be cold, not frozen; medium pressure.
Chocolate	Metal Blade	Chop	1-ounce (30 ml) = ¼ cup (50 ml) grated	Cut into ½- to 1-inch (2.5 cm) pieces (or use chocolate chips). Pulse to start, then process to desired consistency. Texture will appear more rounded than grated.
	Shredding Disc	Shred	1-ounce (30 ml) = ¼ cup (50 ml) grated	Chill chocolate; medium to firm pressure.
Crumbs; Bread, Cookies & Crackers	Metal Blade	Chop	12 to 14 graham wafers = 1 cup (250 ml) crumbs; 1 slice bread = ½ cup (125 ml) crumbs	Break up ingredients into ½- to 1-inch (1.25-2.5 cm) pieces. Process until fine. Breadcrumbs: make from fresh, stale or toasted bread.

FOOD	TOOL	PROCESS	YIELD	DIRECTIONS
Egg Whites	Metal Blade	Chop	8 egg whites = 1 cup (250 ml) firm whites	Egg whites should be room temperature; add 1 teaspoon (5 ml) lemon juice or vinegar per white. Process in an absolutely clean bowl for 1 to 2½ minutes until surface develops ridges and mass of whites almost stops moving. These egg whites should not be used in meringues. For whipped egg whites with volume, whip with whisk or electric mixer.
Meat, Poultry & Fish	Metal Blade	Chop	2 pound boneless = 4½ cups (1 L)	Cut <i>very cold</i> raw or cooked meat/poultry/fish into 1-inch (2.5 cm) pieces; pulse to chop. Process for a few seconds at a time for a finer chop. Check texture often to avoid overprocessing.
	Metal Blade	Purée	1 pound boneless = 2 cups (500 ml)	Cut <i>very cold</i> raw or cooked meat/poultry/fish into 1-inch (2.5 cm) pieces; pulse to chop. Process continuously until desired texture.
	Slicing Disc	Slice	1 pound boneless = 2 cups (500 ml)	Slicing cooked meat/poultry: be sure it is <i>very cold</i> . Use a single chunk of meat at a time. Slicing raw meat/poultry: cut to fit feed tube; wrap in plastic to briefly freeze. Raw meat is ready to slice when hard to the touch but can easily be pierced with tip of a sharp knife.
Milk Shakes/Smoothies	Metal Blade	Chop/ Purée	Can make up to 16 8-ounce (227 g) servings.	Milkshakes: add ice cream first; process and add milk through feed tube. Smoothies: add fruit first, then add the liquid while processing.
Nuts	Metal Blade	Chop	¾ pound = 3 cups (750 ml)	Pulse to chop. Hardness of nut dictates amount and time of processing. If either flour or sugar is added to nuts during processing, they can be processed as long as possible without becoming butter. Coarsely chopped nuts: 6 to 8 pulses. Finely chopped nuts: pulse 2 to 3 times, then process 20 to 30 seconds, watching carefully for desired consistency.
	Metal Blade	Purée	¼ pound = 1 cup (250 ml)	Nut butter: process nuts 2 to 3 minutes, scraping bowl as necessary. For smoothest consistency, add some oil to nuts while processing.
	Slicing Disc Shredding Disc	Slice Shred (fine/med.)	¼ pound = 1 cup (250 ml) ¼ pound = 1 cup (250 ml)	Medium pressure; nuts will have a coarse texture. Medium pressure; nuts will have a fine/medium texture.
Granulated Sugar (to make extra super-fine sugar)	Metal Blade	Chop	1 pound = 2 cups (500 ml)	Process 1 minute, or until fine.
Tofu	Metal Blade	Purée	10 ounces = ¾ cup (175 ml)	Drain; process 2 minutes or until smooth.
Whipping Cream	Metal Blade	Chop	1 cup (250 ml) = ½ cup (125 ml) whipped	Process well-chilled cream until cream begins to thicken. Add sugar as desired; process continuously until cream reaches desired consistency (about 3 to 4 minutes).
DOUGHS Pastry Dough	Metal Blade	Mix		Pulse mixture until it has consistency between cornmeal and small pebbly crumbs. Add water, 1 tablespoon (15 ml) at a time; pulse until a dough forms.
Batters Quick Bread, Cake & Cookies	Metal Blade	Mix		First sift dry ingredients together by processing; remove and reserve. Process the fats and sugars together and then add any remaining liquid ingredients. Pulse in reserved dry ingredients. Any ingredients that need to be coarsely chopped can be added with dry ingredients. For finely chopped ingredients, chop separately in small work bowl and then add to batter at the end.
Yeast Dough Breads	Metal Blade Dough Blade	Mix Knead		TIPS: Use ¾ cup (175 ml) warm liquid to proof 2¼ teaspoons (11.25 ml) dry active yeast. Sugar/honey aids in activating yeast, so add a small amount, about 1 teaspoon (5 ml), to the warm liquid/yeast mixture when proofing. Food processor can handle up to 5 cups (1.25 L) white flour for a yeast bread dough. The dough should have a soft, pliable texture and feel only slightly tacky.*
Sweet Dough Breads & Coffee Cakes	Metal Blade Dough Blade	Mix Knead		See TIPS above, but keep in mind that sweet doughs will be rich and sticky and may not clean sides of bowl; bowl may need to be scraped. Sweet doughs require less kneading once the ingredients are mixed.*

Note: Use dough blade for kneading dough in the large bowl only. The small bowl may not be used for dough.

*See troubleshooting for additional direction and techniques.

CLEANING, STORAGE AND MAINTENANCE

Keep your Cuisinart Elite Collection™ 12-Cup (3 L) Food Processor ready to use on the kitchen counter. When not in use, leave it unplugged.

Keep the blades and discs out of the reach of children.

All parts except the housing base are dishwasher safe, and we recommend washing them in the dishwasher on the **top rack only**. Due to intense water heat, washing the work bowl, cover and accessories on the bottom rack may cause damage over time. Insert the cover with the feed tube facing up to ensure proper cleaning of the seal. (Note: The seal is not removable and water will drain properly.) Insert the work bowl and pushers upside down for drainage. Remember to unload the dishwasher carefully wherever you place sharp blades and discs.

To simplify cleaning, rinse the work bowl, cover, pusher assembly and blade or disc immediately after use so food won't dry on them. Be sure to place the pushers upside down for drainage. If food lodges in the pusher, remove it by running water through it, or use a bottle brush.

If further cleaning of the cover is necessary after dishwashing or handwashing, run faucet water pressure directly through the holes in the cover, while pushing up and down on the rubber seal.

If you wash blades and discs by hand, do it carefully. When handling, use the plastic hubs on the blades and discs. Avoid leaving them in soapy water where they may disappear from sight. To clean the metal blade, fill the work bowl with soapy water, hold the blade by its plastic center and move it rapidly up and down on the center shaft of the bowl. Use of a spray attachment is also effective. If necessary, use a brush. The work bowl is made of durable plastic, that is shatter resistant and heat resistant. It should not be placed in a microwave oven, as the aperture at the front of the pusher houses the metal rod that activates the motor. The housing base may be wiped clean with a soapy, non-abrasive material. Be sure to dry once clean.

Four rubber feet on the underside keep the base from moving on most work surfaces when the machine is processing heavy loads. If the feet leave spots on the counter, spray them with a spot remover and wipe with a damp sponge. If any trace of the spot remains, repeat the procedure and wipe the area with a damp sponge and nonabrasive cleaning powder.

IMPORTANT: Never store any blade or disc on the motor shaft. No blade or disc should be placed on the shaft except when the processor is about to be

used.

MAINTENANCE: Any other servicing should be performed by an authorized service representative.

FOR YOUR SAFETY

Like all powerful electrical appliances, a food processor should be handled with care. Follow these guidelines to protect yourself and your family from misuse that could cause injury.

Handle and store metal blades and discs carefully. Their cutting edges are very sharp.

Always place the stem adapter on the motor shaft before assembling the discs.

Never put blades or discs on the motor shaft until the work bowl is locked in place.

Always be sure that the blade or disc is down on motor shaft as far as it will go.

Always insert chopping blade and dough blade in the work bowl before putting ingredients in bowl.

When slicing or shredding food, always use the pusher. Never put your fingers or spatula into feed tube.

Always wait for the blade or disc to stop spinning before you remove the pusher assembly or cover from the work bowl.

Always unplug the unit before removing food, cleaning, or putting on or taking off parts.

Always remove work bowl from base of machine before you remove chopping blade or dough blade.

TECHNICAL DATA

The motor in your food processor operates on a standard line operating current. The appropriate voltage and frequency for your machine are shown on a label on the bottom of the base.

An automatic, temperature-controlled circuit breaker in the motor ensures complete protection against motor burnout. If the processor runs for an exceptionally long time when chopping, mixing or kneading a thick or heavy mixture in successive batches, the motor may overheat. If this happens, the processor will stop. Turn it off and wait for the motor to cool before proceeding. It will usually cool within 10 minutes. In extreme cases, it could take an hour.

Safety switches prevent the machine from operating when the work bowl or the cover is not locked into position. The motor stops within seconds when the motor is turned off, and when the pusher assembly is removed, a fast-stop circuit also enables the motor to stop within seconds.

Cuisinart offers a Limited Three-Year Warranty on the entire machine.

TROUBLESHOOTING

Food Processing

1. **Problem:** The food is unevenly processed

Solution:

- The ingredients should be cut evenly into ½- to 1-inch (1.3-2.5 cm) pieces before processing.

- Process in batches to avoid overloading.

2. **Problem:** Slices are uneven or slanted

Solution:

- Place evenly cut food into the feed tube.
- Apply even pressure on the pusher.

3. **Problem:** Food falls over in feed tube

Solution:

- Large feed tube must be packed full for best results. If processing smaller quantities, use the small feed tube.

4. **Problem:** Some food remains on top of the disc.

Solution:

- It is normal for small pieces to remain; cut remaining bits by hand and add to processed ingredients.

Dough Processing

1. **Problem:** Motor slows down.

Solution:

- Amount of dough may exceed maximum capacity of your food processor. Remove half and process in two batches.

- Dough may be too wet (see number 9). If motor speeds up, continue processing. If not, add more flour, 1 tablespoon (15 ml) at a time until the motor speeds up. Process until dough cleans the side of the work bowl.

2. **Problem:** Blade doesn't incorporate ingredients.

Solution:

- Always start the food processor before adding liquid. Add liquid in a slow, steady stream, allowing the dry ingredients to absorb it. If too much liquid is added, wait until ingredients in the work bowl have mixed, then add remaining liquid slowly (do not turn off the machine). Pour liquid onto dough as it passes under feed tube opening; do not pour liquid directly onto bottom of the work bowl.

3. **Problem:** Blade rises in work bowl

Solution:

- Excessively sticky dough can cause blade to rise. Reinsert blade and immediately add 2 tablespoons (30 ml) of flour through the feed tube while the machine is running.

4. **Problem:** The large pusher moves when processing dough or other heavy loads.

Solution:

- The pusher lock feature, located above the handle, should be pulled out (some vibration is normal).

5. **Problem:** Dough doesn't clean inside of the work bowl.

Solution:

- Amount of dough may exceed maximum capacity of your food processor. Remove half and process in two batches.
- Dough may be too dry (see number 8).
- Dough may be too wet (see number 9).

6. **Problem:** Nub of dough forms on top of blade and does not become uniformly kneaded.

Solution:

- Stop machine, carefully remove dough, divide it into 3 pieces and redistribute them evenly in the work bowl.

7. **Problem:** Dough feels tough after kneading

Solution:

- Divide dough into 2 or 3 pieces and redistribute evenly in bowl. Process 10 seconds or until uniformly soft and pliable.

8. **Problem:** Dough is too dry.

Solution:

- While machine is running, add water, 1 tablespoon (15 ml) at a time until dough cleans the inside of the bowl.

9. **Problem:** Dough is too wet.

Solution:

- While machine is running, add flour, 1 tablespoon (15 ml) at a time until dough cleans the inside of the bowl.

Technical

1. **Problem:** The motor does not start.

Solution:

- There is a safety interlock to prevent the motor from starting if it is not properly assembled. Make sure the work bowl and work bowl cover are securely locked into position.

- If you are slicing or shredding and the above solution does not work, make sure that the food contents in the feed tube are cut below the maximum fill line so that the activation rod can engage the motor.

- If the motor still will not start, check the power cord and outlet.

2. **Problem:** The food processor shuts off during operation.

Solution:

- The cover may have become unlocked; check to make sure it is securely in position.
- A safety protector in the motor prevents the motor from overheating, which is caused by excessive strain. Press the Off control button and wait 10 to 15 minutes to allow the food processor to cool off before resuming.

3. **Problem:** The food processor cover becomes unlatched in the back and/or makes a loud noise.

Solution:

- The back of the cover becoming unlatched, and any related noise, will not prevent the unit from working. Simply push down to lock the back into position.

4. **Problem:** The motor slowed down during operation.

Solution:

- This is normal as some heavier loads (e.g. slicing/shredding cheese) may require the motor to work harder. Simply reposition the food in the feed tube and try again.
- The maximum load capacity may have been exceeded. Remove some of the ingredients and continue processing.

5. **Problem:** It is difficult to remove the chopping/mixing blade from the work bowl.

Solution:

- These innovative blades have been designed to lock in the work bowl to prevent them from falling out when emptying the contents of the bowl. Using extreme care, use a little extra force to remove the blade.

6. **Problem:** The food processor vibrated/moved around the countertop during processing.

Solution:

- Make sure the rubber feet at the bottom of the unit are clean and dry. Also make sure that the maximum load capacity is not being exceeded.

- This is normal as some heavier loads (e.g. slicing/shredding cheese) may require the motor to work harder.

7. **Problem:** The large pusher falls out when the cover is turned upside down.

Solution:

- The pusher lock feature, located above the handle, should be pulled out.

WARRANTY

LIMITED THREE-YEAR

WARRANTY

We warrant that this Cuisinart product will be free of defects in materials or workmanship under normal home use for 3 years from the date of original purchase. This warranty covers manufacturer's defects including mechanical and electrical defects. It does not cover damage from consumer abuse, unauthorized repairs or modifications, theft, misuse, or damage due to transportation or environmental conditions. Products with removed or altered identification numbers will not be covered.

This warranty is not available to retailers or other commercial purchasers or owners. If your Cuisinart product should prove to be defective within the warranty period, we will repair it or replace it if necessary. For warranty purposes, please register your product online at www.cuisinart.ca to facilitate verification of the date of original purchase and keep your original receipt for the duration of the limited warranty. This warranty excludes damage caused by accident, misuse or abuse, including damage caused by overheating, and it does not apply to scratches, stains, discolouration or other damage to external or internal surfaces that does not impair the functional utility of the product. This warranty also expressly excludes all incidental or consequential damages.

Your Cuisinart product has been manufactured to the strictest specifications and has been designed for use only in 120 volt outlets and only with authorized accessories and replacement parts. This warranty expressly excludes any defects or damages caused by attempted use of this unit with a converter, as well as use with accessories, replacement parts or repair service other than those authorized by Cuisinart.

If the appliance should become defective within the warranty period, do not return the appliance to the store. Please contact our Customer Service Centre:

Toll-free phone number:
1-800-472-7606

Address:

Cuisinart Canada
100 Conair Parkway
Woodbridge, Ont. L4H 0L2

Email: consumer_Canada@conair.com

Model: FP-12C Series

To facilitate the speed and accuracy of your return, please enclose:

- \$10.00 for shipping and handling of the product (cheque or money order)
- Return address and phone number
- Description of the product defect
- Product date code*/copy of original proof of purchase
- Any other information pertinent to the product's return

* Product date code can be found on the underside of the base of the product. The product date code is a 4 or 5 digit number. Example, 90630 would designate year, month & day (2009, June 30th).

Note: We recommend you use a traceable, insured delivery service for added protection. Cuisinart will not be held responsible for in-transit damage or for packages that are not delivered to us.

To order replacement parts or accessories, call our Customer Service Centre at 1-800-472-7606.

For more information, please visit our website at www.cuisinart.ca

©2013 Cuisinart
100 Conair Parkway
Woodbridge, Ontario L4H 0L2
Printed in China
12CC131423

IB-8477B-CAN-E



RECIPES

To help you feel right at home with your new Cuisinart Elite Collection™ 12-Cup Food Processor in your kitchen, we've assembled a variety of delicious recipes to get you started – from quick and easy to more complex gourmet dishes. Breakfast and brunch through dinner and dessert, every meal is covered with these easy-to-follow recipes.

Look for the chef's whisks above the ingredients for the degree of difficulty (1=easy, 2=medium, 3=challenging), and the convenient clock icons that point you to each recipe's time commitment so you can allocate your time accordingly.

In addition, the detailed nutritional information lets you know exactly what you're eating! Bon appétit!

BASICS

Basic Fresh Breadcrumbs	5
BUTTERS	
Gorgonzola Butter	6
Peanut Butter	6
MARINADES & DRESSINGS	
Sweet and Sour Marinade	7
Herbed Vinaigrette	7
Basic Mayonnaise	8
SAUCES	
Basil Pesto	9
Simple Tomato Sauce	10
Hollandaise Sauce	11
Tartar Sauce	11
DOUGHS	
Pizza Dough	12
Pasta Dough	13
Basic Flaky Pastry Dough	14
Pâte Brisée	15
Pâte Sucrée	16

BREAKFAST & BRUNCH

Mixed Mushroom and Red Pepper Frittata	17
White and Sweet Potato Hash with Fennel	18

APPETIZERS

Artichoke and Herb Yogurt Dip	19
Chunky Guacamole	20
Hummus	21
Three Tomato Salsa	22
Classic Bruschetta	23
Caramelized Onion, Steak and Gruyère Quesadillas	24

SOUPS

Lightened Broccoli and Potato Soup	25
Simple Tomato Soup	26
Roasted Butternut Squash Soup	27
French Onion Soup	28

SALADS

Chopped Salad	29
Classic Coleslaw	30

ENTRÉES

Classic Meatballs	31
Chicken Marsala	32
Crab Cakes	33

SIDES

Stuffed Roasted Peppers	34
Mashed Potatoes	35

BREADS

Classic Cuisinart® White Bread	36
Classic Cuisinart® Wheat Bread	37
Buttery Dinner Rolls	38
Popovers	39

DESSERTS

Classic Cheesecake & Graham Cracker Crust	40
Apple Crumb Pie & Crumb Pie Topping	41
Banana Cream Pie & Chocolate Cookie Crust	42
Pastry Cream	43
Deep Chocolate Layer Cake & Cream Cheese Frosting	44
Dessert Crêpes with Berries	45
Raspberry Sauce	46

BASIC FRESH BREADCRUMBS

There is no need to buy breadcrumbs when you can make them in no time with your Cuisinart® Food Processor.



6 SLICES WHITE BREAD

Makes 1⅓ cups (325 ml)

Approximate preparation time: Less than one minute, plus 35 minutes for baking

Preheat oven to 325°F (160°C). Bake slices of bread in a single layer for about 20 minutes or until bread is completely dried out.

Insert the large metal chopping blade into the large work bowl of the Cuisinart® Food Processor. Break toasted bread up into pieces and pulse about 10 times and then process until breadcrumbs are fine, about 25 seconds.

TIP: For seasoned breadcrumbs, add ¼ teaspoon (1 ml) each dried oregano, dried basil, garlic powder, and ground onion flakes.

Nutritional information per serving (2 tablespoons (30 ml)):

Calories 60 (11% from fat) | carb. 11g | pro. 2g | fat 1g | sat. fat 0g | chol. 0mg | sod. 90mg | calc. 10mg | fiber 1g

GORGONZOLA BUTTER

Melt a slice of this butter on your favourite steak right when it comes off the grill. It is also delicious on a baked potato or steamed vegetables.



8 TABLESPOONS (½ CUP (125 ML; 1 STICK) UNSALTED BUTTER, ROOM TEMPERATURE
¼ CUP (50 ML) GORGONZOLA, CRUMBLED
PINCH FRESHLY GROUND BLACK PEPPER

Makes 1 roll compound butter, 16 slices

Approximate preparation time: 5 minutes

Insert the large metal chopping blade into the large work bowl of the Cuisinart® Food Processor. Add the butter and Gorgonzola and process for 60 seconds until smooth, scraping the bowl as necessary.

Remove butter from bowl and place on a sheet of waxed paper. With the aid of the paper, form the butter into a log. Roll and wrap well in plastic. Butter can either be refrigerated or frozen.

Nutritional information per serving (1 tablespoon (15 ml)):

Calories 52 (96% from fat) | carb. 0g | pro. 0g | fat 6g | sat. fat 4g | chol. 16 mg | sod. 5mg | calc. 2mg | fiber 0g

PEANUT BUTTER

Makes 2 cups (500 ml)

Approximate preparation time: 4½ minutes

Insert the large metal chopping blade into the large work bowl of the Cuisinart® Food Processor. Pulse peanuts about 10 times and then process until drops of oil are visible and the mixture is very smooth, about 4½ minutes.

TIP: Any nut can be substituted in this recipe.

Nutritional information per serving (1 tablespoon (15ml)):

Calories 100 (71% from fat) | carb. 4g | pro. 4g | fat 9g | sat. fat 1g | chol. 0mg | sod. 1mg | calc. 9mg | fiber 1g

SWEET AND SOUR MARINADE

This marinade pairs well with poultry and pork.



- 4 GARLIC CLOVES
- ½ CUP (125 ML) DARK CORN SYRUP
- ½ CUP (125 ML) EXTRA VIRGIN OLIVE OIL
- ½ CUP (125 ML) BALSAMIC VINEGAR
- 1 TABLESPOON (15 ML) PLUS 1 TEASPOON (5 ML) PAPRIKA
- 2 TEASPOONS (10 ML) DRY MUSTARD POWDER
- 2 TEASPOONS (10 ML) DRIED THYME
- 1 TEASPOON (5 ML) CHILI POWDER
- 1 TEASPOON (5 ML) KOSHER SALT

Makes 1 cup (250 ml)

Approximate preparation time: 5 minutes

Insert the small metal chopping blade into the small work bowl of the Cuisinart® Food Processor. Add the garlic and process to finely chop. Add the remaining ingredients. Process again until well mixed, about 45 seconds.

Nutritional information per serving (1 tablespoon (15 ml)):
Calories 97 (62% from fat) | carb. 10g | pro. 0g | fat 7g | sat. fat 1g | chol. 0mg | sod. 152mg | calc. 4mg | fiber 0g

HERBED VINAIGRETTE

A classic vinaigrette – toss with mixed greens or drizzle over grilled chicken.



- ¼ CUP (50 ML) RED WINE VINEGAR
- 1 TEASPOON (5 ML) DIJON-STYLE MUSTARD
- ¼ CUP (50 ML) FRESH PARSLEY
- ½ TEASPOON (2 ML) DRIED BASIL
- ½ TEASPOON (2 ML) DRIED THYME
- ½ TEASPOON (2 ML) DRIED MARJORAM
- ½ TEASPOON (2 ML) KOSHER SALT
- ¼ TEASPOON (1 ML) GROUND WHITE PEPPER
- ¾ CUP (175 ML) EXTRA VIRGIN OLIVE OIL

Makes 1 cup (250 ml)

Approximate preparation time: 5 minutes

Insert the small metal chopping blade into the small work bowl of the Cuisinart® Food Processor. Add the vinegar, mustard, parsley and remaining herbs and spices and process to combine. With machine running, slowly pour the olive oil through the feed tube until all ingredients are homogenous, about 45 to 60 seconds.

Nutritional information per serving (1 tablespoon (15 ml)):
Calories 91 (99% from fat) | carb. 0g | pro. 0g | fat 11g | sat. fat 2g | chol. 0mg | sod. 76mg | calc. 2mg | fiber 0g

BASIC MAYONNAISE

Taste the difference in homemade mayonnaise.



- 2 LARGE EGG YOLKS*
- ¼ TEASPOON (1 ML) KOSHER SALT
- 1 TABLESPOON (15 ML) DIJON-STYLE MUSTARD
- 1 TEASPOON (5 ML) FRESH LEMON JUICE OR WHITE WINE VINEGAR
- 1 TO 1½ CUPS (250-375 ML) VEGETABLE OR CANOLA OIL

Makes about 1½ cups (375 ml)

Approximate preparation time: 5 to 10 minutes

Insert the large metal chopping blade into the large work bowl of the Cuisinart® Food Processor. Process the egg yolks, salt, mustard and lemon juice until smooth, about 30 seconds. With the machine running, very gradually drizzle the oil through the feed tube until mixture thickens. (Adding the oil through the drizzle hole located in the feed tube pusher will yield best results.) Taste and adjust seasoning accordingly.

For fresh herb mayonnaise: process ½ cup (75 ml) firmly packed fresh herbs (i.e., parsley, dill, tarragon, basil, etc.), stems removed, with the yolks before adding the oil.

*Raw egg warning:

Caution is suggested in consuming raw and lightly cooked eggs due to the slight risk of salmonella or other food-borne illness. To reduce this risk, we recommend you use only fresh, properly refrigerated, clean, grade A or AA eggs with intact shells, and avoid contact between the yolks or whites and the shell.

For lower-cholesterol mayonnaise, and to avoid using raw eggs, Egg Beaters® may be substituted for the egg yolks.

Nutritional information per serving (1 tablespoon (15 ml)):
Calories 85 (98% from fat) | carb. 0g | pro. 0g | fat 10g | sat. fat 1g | chol. 17mg | sod. 38mg | calc. 2mg | fiber 0g

BASIL PESTO

If you have other herbs or nuts, use them in place of some of the basil and pine nuts.



- 3 OUNCES (85 G) REGGIANO PARMIGIANO CHEESE, CUT INTO 1/2-INCH (1.25 CM) CUBES
- 2 GARLIC CLOVES
- 1/2 CUP (125 ML) PINE NUTS OR WALNUTS, LIGHTLY TOASTED
- 5 CUPS (1.25 ML) TIGHTLY PACKED FRESH BASIL LEAVES, UNBLEMISHED (ABOUT 20 OUNCES)
- 1/4 TO 1/2 TEASPOON (1 ML- 2ML) KOSHER OR SEA SALT
- 2/3 TO 3/4 CUP (150-175 ML) EXTRA VIRGIN OLIVE OIL

Makes about 2 cups (500 ml)

Approximate preparation time: 5 minutes

Insert the large metal chopping blade into the large work bowl of the Cuisinart® Food Processor. With the machine running, drop the cheese and garlic through the small feed tube to process until finely chopped, about 30 seconds. Add the nuts and pulse to chop, about 5 to 6 pulses. Add the basil leaves and pulse to chop, 10 to 15 times; scrape the bowl. Add the salt. With the machine running, add the olive oil in a slow, steady stream through the small feed tube, processing until combined and an emulsion is formed, about 1 minute. Scrape the work bowl.

To store the pesto, transfer to a glass jar or bowl, tap to remove all air bubbles and even out the surface. Float a layer of olive oil on top; cover with plastic wrap and refrigerate. The pesto will keep for 5 days in the refrigerator, or it may be frozen.

Nutritional information per serving (1 tablespoon (15 ml)):

Calories 51 (87% from fat) | carb. 1g | pro. 1g | fat 5g | sat. fat 1g | chol. 1mg | sod. 88mg | calc. 34mg | fiber 0g

SIMPLE TOMATO SAUCE

A simple marinara sauce for pasta, or when reduced, a tasty topping for homemade pizzas.



- 1 SMALL ONION (ABOUT 4 OUNCES (115 G)), CUT INTO 1-INCH (2.5 CM) PIECES
- 1/2 TABLESPOON (7 ML) EXTRA VIRGIN OLIVE OIL
- 4 GARLIC CLOVES
- 3/4 TEASPOON (3.75 ML) DRIED OREGANO
- 1 CAN (35 OUNCES) PLUM TOMATOES, WITH JUICES
- 2 SPRIGS FRESH BASIL (10 TO 12 LARGE LEAVES)
- 1/4 CUP (50 ML) DRY WHITE WINE
- 1/2 TEASPOON (2 ML) KOSHER SALT
- 1/4 TEASPOON (1 ML) FRESHLY GROUND BLACK PEPPER
- 1/4 TO 3/4 TEASPOON (1-3.75 ML) RED PEPPER FLAKES (OPTIONAL, TO TASTE, FOR A SPICIER SAUCE)

Makes 3 cups (750 ml) tomato sauce for pasta / 1 3/4 cups (425 ml) tomato sauce for pizza.

Approximate preparation time: 10 to 15 minutes, plus 1 hour cooking (cook an additional 40 minutes to make the reduced pizza sauce)

Insert the large metal chopping blade into the large work bowl of the Cuisinart® Food Processor. Add the onion and pulse to chop, about 10 times. Put the olive oil into a 6-quart saucepan over medium heat. When the oil shimmers across the pan, add the onion. With the processor running, drop the garlic through the feed tube to chop. Add the garlic and oregano to the pan. Cook until onion is softened and the garlic is fragrant. While the onion mixture is cooking, add the tomatoes to the work bowl and pulse to chop. Add the tomatoes to the pan with the basil, wine and salt. Bring to a boil and then reduce the heat to low, cover the pan loosely and simmer for 50 to 60 minutes. Turn off the heat and let cool in the pan for 10 minutes. Stir in the black pepper and optional red pepper flakes. Taste and adjust seasoning accordingly.

If you would like a sauce for pizza, continue to simmer, uncovered, for 40 additional minutes to reduce, stirring now and then. Transfer the reduced sauce to a bowl to cool before using as a pizza topping.

This sauce freezes well.

Nutritional information per serving (1/2 cup (125 ml)):

Calories 46 (22% from fat) | pro. 2g | carb. 6g | fat 1g | sat. fat 0g | chol. 0mg | sod. 457mg | calc. 91mg | fiber 1g

Nutritional information per serving (1/2 cup (125 ml)): reduced for pizza sauce

Calories 74 (22% from fat) | pro. 3g | carb. 10g | fat 2g | sat. fat 0g | chol. 0mg | sod. 732mg | calc. 91mg | fiber 2g

HOLLANDAISE SAUCE

This sauce can be used in many dishes, including eggs benedict and steamed vegetables.



- 24 TABLESPOONS (¾ POUND (375 G); 3 STICKS) UNSALTED BUTTER
- 3 LARGE EGG YOLKS
- ½ TEASPOON (2 ML) DRY MUSTARD
- ½ TEASPOON (2 ML) KOSHER SALT
- ¼ TEASPOON (1 ML) FRESHLY GROUND BLACK PEPPER
- 2 TABLESPOONS (30 ML) FRESH LEMON JUICE

Makes 1½ cups (375 ml)

⌚ Approximate preparation time: 15 minutes

Place butter in a saucepan over low heat to melt.

Insert the large chopping blade into the large work bowl of the Cuisinart® Food Processor. Add the yolks, mustard, salt and pepper and process for 90 seconds. Once the butter is melted, turn heat up to bring the butter just to a boil. With the machine running, slowly drizzle the hot butter through the feed tube. Sauce will thicken to a mayonnaise consistency. When all butter has been incorporated, add the lemon juice and pulse to incorporate. Taste and adjust seasoning accordingly. Serve while still warm.

Nutritional information per serving (1 tablespoon (15 ml)):

Calories 108 (98% from fat) | carb. 0g | pro. 0g | fat 12g | sat. fat 7g | chol. 57mg | sod. 45mg | calc. 3mg | fiber 0g

TARTAR SAUCE

This tartar sauce is good not only with fish and shellfish, but also with steamed fresh vegetables.



- 2 OUNCES (60 G) SHALLOTS OR GREEN ONIONS, TRIMMED AND CUT INTO 1-INCH (2.5 CM) PIECES
- 3 OUNCES (85 G) DRAINED SWEET GHERKIN PICKLES
- 4 TABLESPOONS (60 ML) FRESH ITALIAN PARSLEY
- 1 TABLESPOON (15 ML) DILL WEED
- 1 TABLESPOON (15 ML) DIJON-STYLE MUSTARD
- ½ TEASPOON (2 ML) DRIED THYME
- 3 TABLESPOONS (45 ML) DRAINED CAPERS
- 1½ CUPS (375 ML) MAYONNAISE
- ½ CUP (125 ML) NONFAT PLAIN YOGURT, DRAINED* OVERNIGHT
- ⅛ TEASPOON (0.5 ML) FRESHLY GROUND BLACK PEPPER

Makes about 2 cups (500 ml)

⌚ Approximate preparation time: 5 minutes

Insert the large metal chopping blade into the large work bowl of the Cuisinart® Food Processor. Add the shallots, gherkins and parsley and pulse to chop, about 15 pulses. Add the dill, mustard, thyme, and capers and pulse 5 times to chop. Add the mayonnaise, yogurt and black pepper; pulse to combine, 5 times. Do not overprocess. Refrigerate until ready to use.

*To drain yogurt, place in a strainer lined with a coffee filter or a yogurt strainer. Cover and let drain until desired thickness is reached.

Nutritional information per serving (1 tablespoon (15 ml)):

Calories 72 (88% from fat) | carb. 2g | pro. 0g | fat 7g | sat. fat 1g | chol. 13mg | sod. 86mg | calc. 10mg | fiber 0g

PIZZA DOUGH

Once you see how simple pizzas are to make, you will never order one to be delivered again!



- 1 PACKAGE ACTIVE DRY YEAST
- 1 TEASPOON (5 ML) GRANULATED SUGAR
- 1¼ CUPS (300 ML) WARM WATER (105° TO 115°F (41° TO 46°C.))
- 3⅓ CUPS (825 ML) UNBLEACHED, ALL-PURPOSE FLOUR
- ½ TABLESPOON (7 ML) KOSHER SALT
- 2 TEASPOONS (10 ML) EXTRA VIRGIN OLIVE OIL

Makes 1¾ pounds (795 g) dough (six 7-inch (18 cm) crusts or three 12-inch (30 cm) crusts) / 36 servings

⌚ Approximate preparation time: 5 to 10 minutes, plus 55 minutes rising and resting, 5 minutes assembly and 10 minutes baking

In a 2-cup (500 ml) liquid measure, dissolve yeast and sugar in warm water. Let stand until foamy, about 3 to 5 minutes. Insert the dough blade into the large work bowl of the Cuisinart® Food Processor and add the flour and salt.

With machine running, pour the liquid slowly through the small feed tube as fast as the flour will absorb it. Once a dough ball forms and cleans the sides of the work bowl, process for an additional 30 seconds to knead dough. Dough may be slightly sticky. Coat dough evenly with extra virgin olive oil and transfer to a plastic food storage bag and seal the top. Let dough rise in a warm place for about 45 minutes.

Place dough on a lightly floured surface; punch down and let rest 5 to 10 minutes. Roll into desired crust sizes and place on baking pans lightly sprayed with vegetable oil cooking spray. Follow pizza recipe.

Nutritional information per serving (1 ounce (30 g)):

Calories 112 (2% from fat) | carb. 24g | pro. 3g | fat 0g | sat. fat 0g | chol. 0mg | sod. 134mg | calc. 0mg | fiber 1g

PASTA DOUGH

Fresh pasta is a special treat. While it is best served right away, you can freeze it after it has been rolled and cut.



- 2 CUPS (500 ML) UNBLEACHED, ALL-PURPOSE FLOUR
- 1 CUP (250 ML) SEMOLINA FLOUR
- 1 TABLESPOON (15 ML) KOSHER SALT
- 4 LARGE EGGS

Makes 1½ pounds (750 g), about 10 servings

Approximate preparation time: 5 minutes

Insert the large metal chopping blade into the large work bowl of the Cuisinart® Food Processor. Add both flours and salt to work bowl and pulse 5 to 6 times to combine. With the machine running, add 1 egg at a time until a dough ball forms. Once dough ball forms, allow machine to run for 30 seconds to knead. Divide dough into 4 equal parts and pass through a pasta roller machine.

Nutritional information per serving:

Calories 165 (12% from fat) | carb. 30g | pro. 7g | fat 2g | sat. fat 1g | chol. 85mg | sod. 668mg | calc. 11mg | fiber 1g

BASIC FLAKY PASTRY DOUGH

This recipe makes ample crust for a 9- to 11-inch (23-28 cm) regular or deep-dish pie or tart.



FOR A ONE-CRUST PIE:

- 1½ CUPS (375 ML) UNBLEACHED, ALL-PURPOSE FLOUR
- ¼ TEASPOON (1 ML) TABLE SALT
- ⅛ TEASPOON (0.5 ML) BAKING POWDER
- 8 TABLESPOONS (¼ POUND (125 G) ; 1 STICK) UNSALTED BUTTER, COLD AND CUT INTO ½-INCH (1.25 CM) CUBES
- 2 TABLESPOONS (30 ML) VEGETABLE SHORTENING (PREFERABLY NON-HYDROGENATED), COLD AND CUT INTO ½-INCH (1.25 CM) CUBES
- 2 TO 4 TABLESPOONS (30-45 ML) ICE WATER

FOR A TWO-CRUST PIE:

- 3 CUPS (750 ML) UNBLEACHED, ALL-PURPOSE FLOUR
- ½ TEASPOON (2 ML) TABLE SALT
- ¼ TEASPOON (1 ML) BAKING POWDER
- 16 TABLESPOONS (½ POUND (250 ML); 2 STICKS) UNSALTED BUTTER, COLD AND CUT INTO ½-INCH (1.25 CM) CUBES
- 4 TABLESPOONS (60 ML) VEGETABLE SHORTENING (PREFERABLY NON-HYDROGENATED), COLD AND CUT INTO ½-INCH (1.25 CM) CUBES
- 5 TO 8 TABLESPOONS (75-120 ML) ICE WATER

Approximate preparation time: 10 minutes, plus 30 minutes resting time

Insert the large metal chopping blade into the large work bowl of the Cuisinart® Food Processor. Add the flour, salt and baking powder and process for 10 seconds to sift. Add the well-chilled butter and shortening. Use short quick pulses until the mixture resembles coarse corn meal and no pieces of butter larger than a pea remain visible, 15 to 20 pulses. Sprinkle half the maximum ice water on the flour and butter mixture, then pulse 5 or 6 times. The dough will be crumbly, but should begin to hold together when a small amount is picked up and pressed together. Add more water, a teaspoon (two for the two-crust recipe) at a time, with 2 to 3 quick pulses after each addition, adding just enough water for the dough to hold together easily when pressed into a ball. Do not allow the dough to form a ball in the processor! Add the liquid sparingly so that the dough is not sticky. Do not overprocess or the pastry will be tough, not tender and flaky.

Turn the dough out onto a lightly floured surface. Press together into a ball, then flatten into a disk about 6 inches (15 cm) in diameter (two disks for the two-crust recipe). Wrap in plastic wrap and refrigerate for 1 hour before continuing. The dough will keep refrigerated for up to 3 days, or may be frozen (double wrapped) for up to a month; thaw at room temperature for an hour before using. Use as directed in recipe.

To bake the pastry blind for a single-crust filled pie or tart, roll out pastry ⅛-inch (0.3 cm) thick to fit pan; crimp and seal edges. Prick bottom all over with a fork. Chill for 30 minutes. Preheat the oven to 400° F (200°C). Cover the shell with a sheet of aluminum foil or parchment paper and weigh down with pie weights, dry rice or dried beans. Bake for 15 minutes.

TIP: Leftover pastry may be rolled out and cut into shapes to garnish the pie, or brushed with milk, sprinkled with sugar or cinnamon and sugar, and baked until lightly browned.

Nutritional information based on 12 servings per pie: 1-crust pie
Calories 138 (65% from fat) | pro. 1g | carb. 11g | fat 10g | sat. fat 1g | chol. 20mg | sod. 48mg | calc. 2mg | fiber 0g

Nutritional information based on 12 servings per pie: 2-crust pie
Calories 277 (65% from fat) | pro 3g | carb 22g | fat 20g | sat. fat 1g | chol. 40mg | sod. 104mg | calc. 2mg | fiber 0g

PÂTE BRISÉE

This versatile dough can be used for sweet or savoury treats.



- 2 CUPS (500 ML) UNBLEACHED, ALL-PURPOSE FLOUR
- 1 TEASPOON (5 ML) TABLE SALT
- 16 TABLESPOONS (½ POUND (250 G); 2 STICKS) UNSALTED BUTTER, COLD AND CUT INTO ½-INCH (1.25 CM) CUBES
- ¼ CUP (50 ML) ICE WATER

Makes two single crust 9-inch (23 cm) tarts/pies (24 servings), or one double-crust pie, (12 servings)

Approximate preparation time: 5 minutes

Insert the large metal chopping blade into the large work bowl of the Cuisinart® Food Processor. Add the flour and salt and process for 10 seconds to sift. Evenly add the butter and pulse until the mixture resembles coarse crumbs. Pour in water 1 tablespoon (15 ml) at a time, and pulse until mixture just forms a dough – you may not need all of the water. Divide dough equally into two pieces and form each into a flat disc; wrap in plastic and refrigerate until ready to use. This pastry also freezes well for up to 6 months as long as it is well wrapped.

Nutritional information per serving:

Calories 39 (6% from fat) | carb. 8g | pro. 1g | fat 0g | sat. fat 0g | chol. 0mg | sod. 98mg | calc. 2mg | fiber 0g

TIP: For a sweet Pâte Brisée, follow the same recipe as above except add 1½ tablespoons (25 ml) of granulated sugar to the dry ingredients in the work bowl.

Nutritional information per serving:

Calories 47 (5% from fat) | carb. 10g | pro. 1g | fat 0g | sat. fat 0g | chol. 0mg | sod. 98mg | calc. 2mg | fiber 0g

PÂTE SUCRÉE

Have leftover dough? Use this “sweet” dough for simple cookies. Just roll and cut into your favourite shapes.



- 2 CUPS (500 ML) UNBLEACHED, ALL-PURPOSE FLOUR
- 2 TABLESPOONS (30 ML) GRANULATED SUGAR
- ½ TEASPOON (2 ML) TABLE SALT
- 12 TABLESPOONS (¾ CUP (175 ML)) UNSALTED BUTTER, ROOM TEMPERATURE
- 2 LARGE EGG YOLKS
- 1 TABLESPOON (15 ML) ICE WATER
- ¼ TEASPOON (1 ML) LEMON ZEST (OPTIONAL)
- ½ TEASPOON (2 ML) PURE VANILLA EXTRACT

Makes two 9-inch (23 cm) single tarts/pies, or one double-crust pie

Approximate preparation time: 5 minutes

Insert the large metal chopping blade into the large work bowl of the Cuisinart® Food Processor. Add the flour, sugar and salt and process for 10 seconds to sift. Add the butter and process until combined. With the machine running, add the yolks, one at a time, and process until incorporated. Add the water, zest (if using) and vanilla; pulse 3 to 4 times, until combined.

Form dough into 2 flat discs. Wrap in plastic; chill in refrigerator until ready to use.

To make this an almond sucrée, substitute 1 cup (250 ml) of the all-purpose flour for toasted almonds. Finely grind the almonds, and then add the remaining dry ingredients and follow instructions as stated above.

Nutritional information per serving (based on 72 servings):

Calories 92 (58% from fat) | carb. 8g | pro. 1g | fat 6g | sat. fat 4g | chol. 32mg | sod. 23mg | calc. 2mg | fiber 0g

For the almond sucrée:

Nutritional information per serving:

Calories 94 (63% from fat) | carb. 7g | pro. 1g | fat 7g | sat. fat 4g | chol. 32mg | sod. 23mg | calc. 5mg | fiber 0g

MIXED MUSHROOM AND RED PEPPER FRITTATA

Try this frittata paired with a green salad for a light lunch or dinner.



- 3 OUNCES (85 G) PARMESAN, CUT INTO ½-INCH CUBES (1.25 CM)
- 3 GARLIC CLOVES
- 8 OUNCES (227 G) CREMINI MUSHROOMS
- 2 RED BELL PEPPERS, EACH CUT INTO 4 STRIPS
- 1 TEASPOON (5 ML) DRIED THYME
- 1½ TABLESPOONS (25 ML) EXTRA VIRGIN OLIVE OIL
- ¼ TEASPOON (1 ML) KOSHER SALT, DIVIDED
- ½ TEASPOON (2 ML) FRESHLY GROUND BLACK PEPPER, DIVIDED
- 10 LARGE EGGS

Makes 10 servings

Approximate preparation time: 25 minutes, plus 15 minutes for baking

Preheat oven to 350°F (180°C).

Insert the small metal chopping blade into the small work bowl of the Cuisinart® Food Processor and process the Parmesan until finely chopped; remove and reserve. Add the garlic cloves to the small bowl and process until finely chopped; remove bowl and reserve.

Insert the slicing disc assembly, adjusted to 4mm, into the large work bowl and slice the mushrooms. Adjust the disc to 2mm and then slice the red peppers.

Place a 12-inch (30 cm) nonstick skillet* over medium heat. Add the olive oil and swirl the pan to coat the pan surface evenly with the oil. Add the garlic to the skillet and sauté for 2 to 3 minutes, until fragrant. Add the mushrooms, red peppers, thyme, and a pinch each of the salt and pepper. Sauté for about 8 to 10 minutes, until the vegetables have softened.

While vegetables are cooking, beat the eggs together well and stir in the remaining salt and pepper and reserved Parmesan. Once vegetables are soft, reduce heat to medium low and pour the eggs into the skillet; lightly stir to evenly distribute the vegetables. Leave skillet on the heat so that the bottom of the frittata begins to set, about 5 minutes. Place skillet into oven and bake until the top of the frittata is golden and puffed, about 15 to 20 minutes.

Carefully remove skillet from oven and invert onto a cutting board to cut the frittata to serve immediately.

*If not using a nonstick pan, coat the pan with a nonstick cooking spray before adding the eggs. To do so, once the vegetables are sautéed, stir them into beaten eggs; spray the pan before adding the egg and vegetable mixture.

Nutritional information per frittata:

Calories 102 (64% from fat) | carb. 2g | pro. 7g | fat 7g | sat. fat 2g | chol. 212mg | sod. 295mg | calc. 38mg | fiber 1g

WHITE AND SWEET POTATO HASH WITH FENNEL

A twist on traditional hash, this dish could also make a great dinner side dish.



- ¼ CUP (50 ML) FRESH PARSLEY
- 1 SMALL ONION, CUT INTO 1-INCH (2.5 CM) PIECES
- 1 POUND (500 G) YUKON GOLD POTATOES, SCRUBBED WELL
- ½ POUND (250 G) SWEET POTATOES, SCRUBBED WELL
- 1 MEDIUM FENNEL BULB
- 3 TABLESPOONS (45 ML) UN-SALTED BUTTER, DIVIDED
- ¾ TEASPOON (3.75 ML) KOSHER SALT
- ½ TEASPOON (2 ML) FRESHLY GROUND BLACK PEPPER
- ½ TEASPOON (2 ML) DRIED THYME

Makes 5 cups (1.25 L)

Approximate preparation time: 10 minutes, plus 25 minutes for cooking

Insert the small metal chopping blade into the small work bowl of the Cuisinart® Food Processor. Chop the parsley, about 15 seconds; remove and reserve. Add the onions and pulse to chop, about 6 pulses; remove work bowl assembly and reserve.

Insert the slicing disc assembly, adjusted to 6mm, into the large work bowl. Slice both the white and sweet potatoes. Remove sliced potatoes and cut into ½-inch (1.25 cm) dice.

Adjust the slicing disc to 4mm and slice the fennel.

Put 2 tablespoons (30 ml) of butter into a large sauté pan over medium heat. Once the butter has melted, add the onion, potatoes, fennel, salt, pepper and thyme. Sauté vegetables, stirring occasionally, for about 20 to 25 minutes, covering pan for the last 5 to 8 minutes. For a crisper hash, uncover and toss over heat for an additional 5 minutes.

Toss with remaining butter and reserved parsley. Taste, adjusting seasoning accordingly, and serve.

Nutritional information per serving:

Calories 118 (26% from fat) | carb. 20g | pro. 2g | fat 3g | sat. fat 2g | chol. 9mg | sod. 179mg | calc. 26mg | fiber 3g

ARTICHOKE AND HERB YOGURT DIP

A delicious lowfat dip for crudité's or chips.



- 1 OUNCE (30 G) PARMESAN, CUT INTO ½-INCH (1.25 CM) CUBES
- 2 TABLESPOONS (30 ML) FRESH MINT
- ¼ CUP (50 ML) FRESH BASIL
- ¼ CUP (50 ML) FRESH PARSLEY
- 2 JARS (12-OUNCE (340 G)) ARTICHOKE HEARTS
- 16 OUNCES (453 G) PLAIN LOW-FAT YOGURT
- ½ TEASPOON (2 ML) LEMON ZEST
- ½ TEASPOON (2 ML) FRESHLY GROUND BLACK PEPPER
- ¼ TEASPOON (1 ML) KOSHER SALT
- ⅛ TEASPOON (0.5 ML) FRESHLY GROUND NUTMEG

Makes 4 cups (1 L)

Approximate preparation time: 6 minutes, plus optional 2 hours for resting

Insert the large metal chopping blade into the large work bowl of the Cuisinart® Food Processor. Process the Parmesan until finely chopped; remove and reserve. Add the fresh herbs to the work bowl; pulse to chop, about 5 pulses. Add remaining ingredients, including reserved Parmesan; pulse 5 times to combine, and then process until all ingredients are incorporated.

Allow dip to rest at least 2 hours in refrigerator for flavours to develop. Remove from refrigerator ½ hour before serving.

Nutritional information per serving (¼ cup (50 ml)):

Calories 41 (52% from fat) | carb. 3g | pro. 2g | fat 2g | sat. fat 1g | chol. 2mg | sod. 115mg | calc. 73mg | fiber 0g

CHUNKY GUACAMOLE

Make our fresh guacamole for the Sunday game or serve alongside quesadillas for a fun dinner night.



- 1 GARLIC CLOVE
- ½ JALAPEÑO PEPPER, CUT INTO 1-INCH (2.5 CM) PIECES
- ½ SMALL ONION, CUT INTO 1-INCH (2.5 CM) PIECES
- 1 TABLESPOON (15 ML) CILANTRO
- ¼ CUP (50 ML) GRAPE TOMATOES
- 3 RIPE AVOCADOS, HALVED, PITS REMOVED
- 1 TO 2 TABLESPOONS (15-30 ML) FRESH LIME JUICE
- ½ TEASPOON (2 ML) KOSHER SALT

Makes 3 cups (750 ml)

Approximate preparation time: 10 minutes

Insert the large metal chopping blade into the large work bowl of the Cuisinart® Food Processor. With the machine running, drop the garlic through the small feed tube to finely chop. Add the jalapeño to the work bowl and pulse 5 times to chop. Add the onion and pulse 4 times to chop. Add the cilantro and pulse 3 times to chop. Add the tomatoes and pulse 3 times to chop. Scoop out the insides of the avocados directly into work bowl and add the lime juice and salt. Pulse until desired consistency is achieved, about 10 to 12 pulses.

Nutritional information per serving (¼ cup (50 ml)):

Calories 76 (73% from fat) | carb. 5g | pro. 1g | fat 7g | sat. fat 1g | chol. 0mg | sod. 104mg | calc. 8mg | fiber 3g

HUMMUS

The food processor is a perfect tool for a creamy hummus.



- ¼ CUP (50 ML) FRESH ITALIAN PARSLEY LEAVES
- ½ TEASPOON (2 ML) LEMON ZEST
- ½ TEASPOON (2 ML) KOSHER SALT
- 1 GARLIC CLOVE
- 2 CANS (EACH 15½ OUNCES (439 G)) CHICKPEAS
- 2 TABLESPOONS (30 ML) TAHINI
- 2 TABLESPOONS (30 ML) FRESH LEMON JUICE
- 2½ TABLESPOONS (40 ML) WATER
- ½ TEASPOON (2 ML) GROUND CUMIN
- 2 TABLESPOONS (30 ML) EXTRA VIRGIN OLIVE OIL

Makes 2 cups (500 ml)

Approximate preparation time: 10 minutes

Insert the large metal chopping blade into the large work bowl of the Cuisinart® Food Processor. Process the parsley, lemon zest, salt, and garlic together, about 6 seconds. Scrape bowl and repeat. Add remaining ingredients and process until smooth, about 1 minute. Scrape bowl and process again to fully incorporate all ingredients.

Nutritional information per serving (2 tablespoons (30 ml)):

Calories 55 (49% from fat) | carb. 5g | pro. 2g | fat 3g | sat. fat 0g | chol. 0mg | sod. 163mg | calc. 13mg | fiber 1g

THREE TOMATO SALSA

Serve warm tortilla chips alongside this fresh and tangy salsa.



- 5 SPRIGS FRESH CILANTRO
- ½ SMALL VIDALIA ONION, CUT INTO 1-INCH (2.5 CM) PIECES
- 1 SMALL GARLIC CLOVE
- 1 SMALL JALAPEÑO PEPPER, SEEDED
- 1 TEASPOON (5 ML) SEA SALT
- 1 PLUM TOMATO, CUT INTO 1-INCH (2.5 CM) PIECES
- 1 GREEN HOTHOUSE TOMATO, CUT INTO 1-INCH (2.5 CM) PIECES
- 1 YELLOW TOMATO, CUT INTO 1-INCH (2.5 CM) PIECES
- ½ TEASPOON (2 ML) FRESH LIME JUICE

Makes 2 cups (500 ml)

Approximate preparation time: 10 minutes

Insert the large metal chopping blade into the large work bowl of the Cuisinart® Food Processor. Place the cilantro, onion, garlic clove and jalapeño into the work bowl and pulse to chop, about 10 pulses. Add the salt, tomatoes and lime juice and pulse to chop until desired consistency is reached, about 8 to 10 pulses.

Taste and adjust seasoning accordingly.

For better consistency, drain in a strainer to remove excess liquid.

Serve with your favourite tortilla chips.

Nutritional information per serving (¼ cup (50 ml)):

Calories 13 (9% from fat) | carb. 3g | pro. 1g | fat 0g | sat. fat 0g | chol. 0mg | sod. 209mg | calc. 7mg | fiber 1g

CLASSIC BRUSCHETTA

Classic and delicious.



- 4 GARLIC CLOVES
- 1 CUP (250 ML) FRESH BASIL
- 4 CUPS (1 L) TOMATOES, CUT INTO 1-INCH (2.5 CM) PIECES
- ½ TEASPOON (2 ML) KOSHER SALT
- ⅛ TEASPOON (.5 ML) FRESHLY GROUND BLACK PEPPER
- 2 TABLESPOONS (30 ML) EXTRA VIRGIN OLIVE OIL
- 1 TABLESPOON (15 ML) FRESH LEMON JUICE
- ½ BAGUETTE, CUT INTO ½-INCH (1.25 CM) SLICES
- 1 SMASHED GARLIC CLOVE

Makes 30 bruschette

Approximate preparation time: 15 to 20 minutes, including toasting and assembly time

Insert the large metal chopping blade into the large work bowl of the Cuisinart® Food Processor and process the garlic until finely chopped. Add the basil to the work bowl and pulse 5 to 6 times to roughly chop. Add the tomatoes and pulse to roughly chop. Strain mixture, put into a large mixing bowl and toss with the salt, pepper, oil and lemon juice. Taste and adjust seasoning accordingly.

Preheat oven to 400°F (200°C).

Rub the bread slices with the smashed garlic and place on a baking sheet. Bake in oven to toast, about 5 minutes.

Spoon ½ to 1 tablespoon (7-15 ml) of topping on each toasted slice and serve immediately.

Nutritional information per bruschetta:

Calories 80 (19% from fat) | carb. 14g | pro. 2g | fat 2g | sat. fat 0g | chol. 0mg | sod. 176mg | calc. 23mg | fiber 1g

CARAMELIZED ONION, STEAK AND GRUYÈRE QUESADILLAS

Enjoy these grown-up quesadillas at your next cocktail party. Serve with salsa, guacamole and sour cream for dipping.



- 1½ POUNDS (750 G) YELLOW ONIONS
- ¼ CUP (50 ML) UNSALTED BUTTER
- ⅛ TEASPOON (.5 ML) KOSHER SALT
- ⅛ TEASPOON (.5 ML) FRESHLY GROUND BLACK PEPPER
- 4 OUNCES (115 G) GRUYÈRE
- 1 POUND (500 G) SIRLOIN STEAK
- 8 8-INCH (20 CM) FLOUR TORTILLAS
- OLIVE OIL FOR BRUSHING

Makes 16 servings

Approximate preparation time: 1 hour 40 minutes

Insert the slicing disc, adjusted to 3mm, into the large work bowl of the Cuisinart® Food Processor, and slice the onions. Place a large skillet over medium-low heat and add the butter. Once the butter is melted, add the onions with salt and pepper to the skillet and cook over low heat for about 1 hour, until onions are completely soft and caramel in colour.

While onions are caramelizing, replace the slicing disc with the reversible shredding disc on the medium shredding side and process the Gruyère.

Grill or pan-roast the steaks until rare to medium-rare (steaks will continue to cook in the quesadillas). Allow steaks to cool and then thinly slice.

To assemble: evenly place ¼ cup (50 ml) of onions on a tortilla and top with 4 to 5 slices of steak, ⅓ cup (75 ml) of shredded cheese and then top with another tortilla. Repeat with remaining ingredients.

Preheat the Cuisinart® Griddler®, fitted with the griddle plates in the closed position, to 375°F (190°C). Brush the top and bottom tortillas lightly with oil and grill until the cheese is melted and the tortillas are golden and crisp, about 3 minutes.

Quesadillas can also be prepared in a 375°F (190°C) oven, baked on parchment lined baking trays.

To serve: Cut quesadillas into quarters and serve with salsa, guacamole and sour cream.

Note: The flavour of the caramelized onions is well worth the time it takes to prepare them.

Nutritional information per serving:

Calories 166 (44% from fat) | carb. 15g | pro. 8g | fat 8g | sat. fat 4g | chol. 28mg | sod. 208 mg | calc. 112mg | fiber 0g

LIGHTENED BROCCOLI AND POTATO SOUP

This soup is a delicious and healthy substitute for other cream soups.



- 4 OUNCES (115 G) CHEDDAR
- 2 GARLIC CLOVES
- 1 SMALL ONION, CUT INTO 1-INCH (2.5 CM) PIECES
- 2 TABLESPOONS (30 ML) EXTRA VIRGIN OLIVE OIL
- ½ TABLESPOON (7 ML) SEA OR KOSHER SALT, DIVIDED
- 1 TEASPOON (5 ML) FRESHLY GROUND BLACK PEPPER, DIVIDED
- 1 POUND (500 G) POTATOES
- 2 POUNDS (1 KG) BROCCOLI, STEMS PEELED AND FLORETS SEPARATED
- 2½ CUPS (625 ML) SHERRY
- 1 QUART (946 ML) HOT VEGETABLE STOCK
- ¾ TEASPOON (3.75 ML) LEMON ZEST

Makes about 10 cups (2.5 L)

Approximate preparation time: 25 to 30 minutes

Insert the reversible shredding disc assembly on the medium shredding side into the large work bowl of the Cuisinart® Food Processor and shred the cheese. Remove and reserve. Insert the large metal chopping blade. With the machine running, drop the garlic cloves through the small feed tube to finely chop. Add the onion to the work bowl and pulse to chop, about 10 pulses.

Heat the olive oil in a large saucepan over low heat. Add the garlic and onion, with a pinch each of salt and pepper. Sauté until softened, about 8 to 10 minutes.

While vegetables are cooking, insert the slicing disc assembly, adjusted to the 4mm setting, into the large work bowl. Slice the potatoes and the broccoli stems.

Raise the heat to medium and add the potatoes, broccoli stems and a pinch each of the salt and pepper; sauté 2 to 3 minutes, and then add the sherry. Let the sherry cook down until almost evaporated. Add the stock and bring to a boil.

Reduce heat to medium low and stir in the florets, lemon zest, ½ cup (125 ml) of Cheddar, and remaining salt and pepper. Simmer until vegetables are tender.

Strain the soup, reserving the liquid. Place the solids into the large work bowl with the large metal chopping blade and purée until completely smooth, about 1 minute.

Return the purée to the saucepan. Place over medium-low heat and stir in the reserved liquid until desired consistency is achieved. Stir in remaining Cheddar.

Taste and adjust seasoning accordingly.

TIP: This soup is very thick, so add more stock if a thinner consistency is desired.

Nutritional information per serving (1 cup (250 ml)):

Calories 140 (39% from fat) | carb. 17g | pro. 5g | fat 7g | sat. fat 2g | chol. 5mg | sod. 680mg | calc. 71mg | fiber 4g

TOMATO SOUP

The ultimate comfort soup, our recipe takes it to the next level with its smoky bacon flavour.



- 8 OUNCES (226 G) THICK-CUT BACON, CUT INTO SMALL DICE
- 6 OUNCES (170 ML) GRAPE TOMATOES
- 1 MEDIUM ONION, CUT INTO 1-INCH (2.5 CM) PIECES
- 2 MEDIUM CARROTS, CUT INTO 1-INCH (2.5 CM) PIECES
- 1 CELERY STALK, CUT INTO 1-INCH (2.5 CM) PIECES
- 3 TABLESPOONS (45 ML) UNBLEACHED, ALL-PURPOSE FLOUR
- 5 CUPS (1.25 L) WHOLE PLUM TOMATOES IN PURÉE (FROM ABOUT 1½ 28-OUNCE CANS)
- 3 WHOLE SUN-DRIED TOMATOES
- PINCH BAKING SODA
- 3½ CUPS (875 ML) VEGETABLE STOCK
- 1½ TEASPOONS (7 ML) DRIED BASIL
- ¾ TEASPOON (3.75 ML) DRIED MARJORAM
- 1½ TEASPOONS (7 ML) KOSHER SALT
- ¾ TEASPOON (3.75 ML) FRESHLY GROUND BLACK PEPPER

Makes about 8 cups (2 L)

Approximate preparation time: 50 minutes

Put bacon into a 6-quart (5.7 L) saucepan and place over medium heat. Sauté until bacon is cooked through, about 10 to 15 minutes, and add the grape tomatoes to the pan. Cook until tomatoes are bursting, about 10 minutes. Remove and reserve the tomatoes and remove and discard the bacon or reserve for separate use.

While the bacon and tomatoes are cooking, insert the large metal chopping blade into the large work bowl of the Cuisinart® Food Processor. Add the onion and pulse to chop, about 10 pulses. Add the carrots and celery to the work bowl and pulse to chop, about 10 pulses.

Add the onion to the saucepan with the bacon fat and sauté 5 to 7 minutes, or until the onion is softened. Stir in the carrots and celery; sauté for 6 to 8 minutes, until tender. Stir in flour; cook for an additional minute.

Add tomatoes, with their juices, sun-dried tomatoes, reserved grape tomatoes, baking soda, stock and spices. Cover; bring to a slight boil. Reduce heat and uncover, let simmer about 20 minutes.

Carefully process soup until completely puréed. Return to saucepan to heat through.

Taste and adjust seasoning accordingly.

Nutritional information per serving (1 cup (250 ml)):

Calories 160 (55% from fat) | carb. 16g | pro. 3g | fat 10g | sat. fat 5g | chol. 15mg | sod. 870mg | calc. 94mg | fiber 3g

ROASTED BUTTERNUT SQUASH SOUP

A hearty, warming soup for a winter evening.



- 5 POUNDS (2 KG) BUTTERNUT SQUASH, HALVED AND SEEDS REMOVED (ABOUT TWO 2-POUND (1 KG) SQUASH)
- 1 TABLESPOON (15 ML) EXTRA VIRGIN OLIVE OIL
- 2 MEDIUM-LARGE ONIONS, CUT INTO 1-INCH (2.5 CM) PIECES
- 4 TABLESPOONS (60 ML) (½ STICK) UNSALTED BUTTER
- 2½ TEASPOONS (13 ML) KOSHER SALT, DIVIDED
- 1 TABLESPOON (15 ML) LIGHT OR DARK BROWN SUGAR
- ¼ CUP (50 ML) FINELY CHOPPED FRESH GINGER
- 2 QUARTS (1.89 L) VEGETABLE STOCK
- 1½ TEASPOONS (7 ML) GROUND NUTMEG
- ¾ TEASPOON (3.75 ML) FRESHLY GROUND BLACK PEPPER

Makes about 12 cups (3 L)

Approximate preparation time: 65 to 75 minutes

Preheat oven to 375°F (160°C).

Place squash in a shallow roasting pan. Drizzle olive oil over flesh and into the pan. Turn squash flesh down. Bake until squash is tender, about 45 minutes.

Insert the large metal chopping blade into the large work bowl of the Cuisinart® Food Processor. Add the onions and pulse to chop, about 8 to 10 pulses.

Melt the butter in a 6-quart (5.7 L) saucepan over medium heat. Once the butter has melted, add the onions and ¼ teaspoon (1 ml) of salt. Sauté 5 to 7 minutes, or until the onions are softened. Stir in the brown sugar; sauté for an additional 10 minutes. Add the ginger; sauté until tender and aromatic, about 6 to 8 minutes.

Add stock, roasted squash, nutmeg, remaining salt and pepper to the pot. Cover; bring to a slight boil. Once boiling, uncover and let simmer for 15 to 20 minutes. Strain the soup, reserving the liquid. Place the solids into the large work bowl with the large metal chopping blade and purée until completely smooth, about 1 minute.

Return purée to the saucepan over medium-low heat and stir in the reserved liquid until desired consistency is achieved.

Adjust seasoning to taste and serve.

Nutritional information per serving (1 cup (250 ml)):

Calories 200 (60% from fat) | carb. 19g | pro. 2g | fat 14g | sat. fat 4g | chol. 10mg | sod. 470mg | calc. 69mg | fiber 1g

FRENCH ONION SOUP

Homemade veal stock really adds to the flavour of the rich soup. But if you have a store-bought stock, make sure that it is a high-quality brand.



- 4 POUNDS (1.8 KG) YELLOW ONIONS, PEELED
- 1 CUP (250 ML) (½ POUND; 2 STICKS) UNSALTED BUTTER
- 2 TEASPOONS (10 ML) KOSHER SALT, DIVIDED
- 1 TEASPOON (5 ML) FRESHLY GROUND BLACK PEPPER, DIVIDED
- 20 OUNCES (567 G) GRUYÈRE
- 2 TABLESPOONS (30 ML) UNBLEACHED, ALL-PURPOSE FLOUR
- 3 QUARTS (2.8 L) BEEF OR VEAL STOCK
- 2 TABLESPOONS (30 ML) FRESH THYME
- 2 BAY LEAVES
- 2 CUPS (500 ML) DRY SHERRY
- 1 BAGUETTE, CUT INTO ½-INCH (1.25 CM) SLICES

Makes 20 servings

Approximate preparation time: about 2½ hours

Insert the slicing disc assembly, adjusted to 4mm, into the large work bowl of the Cuisinart® Food Processor and slice the onions.

Melt the butter in an 8-quart (7.6 L) stockpot placed over low heat. Once the butter has melted, add the onions and ¼ teaspoon (1 ml) of both the salt and pepper. Let the onions cook until deeply caramelized, about 1 hour.

While the onions are cooking, replace the slicing disc with the reversible shredding disc on the medium shredding side to shred the Gruyère; reserve in the bowl.

Once onions have cooked, stir in the flour and cook for about 1 to 2 minutes. Add the stock, thyme and bay leaves. Increase the temperature to medium high and bring the mixture to a simmer. Add the sherry and return to a simmer. Reduce the temperature to low and let cook for 50 minutes. Stir in remaining salt and pepper. Taste and adjust seasoning accordingly.

While soup is cooking, lightly toast the baguette slices under a broiler; reserve. Once soup is ready, place in individual, ovenproof crocks and place the bread slices over soup and top with the reserved Gruyère. Broil until the cheese is completely melted and browned. Serve immediately.

Nutritional information per serving (1 cup (250 ml)):

Calories 311 (53% from fat) | carb. 21g | pro. 13g | fat 19g | sat. fat 11g | chol. 54mg | sod. 806mg | calc. 318mg | fiber 2g

CHOPPED SALAD

This delicious, garden-fresh salad is always a big hit – even among non-salad eaters!



- 2 CELERY STALKS, CUT INTO 1-INCH (2.5 CM) PIECES
- 2 MEDIUM CARROTS, ABOUT 4 OUNCES (115 G), CUT INTO 1-INCH (2.5 CM) PIECES
- 1/2 RED ONION, CUT INTO 1-INCH (2.5 CM) PIECES
- 3/4 CUP (175 ML) FLAT LEAF PARSLEY
- 6 SCALLIONS, TRIMMED AND CUT INTO 1-INCH (2.5 CM) PIECES
- 3/4 CUCUMBER, ABOUT 12 OUNCES (340 G), CUT INTO 1-INCH (2.5 CM) PIECES
- 3/4 POUND (375 G) RIPE TOMATOES, CUT INTO 1-INCH (2.5 CM) PIECES
- 1 1/2 CUPS (375 ML) CORN, FRESH OR FROZEN THAWED
- 1 CAN (15 OUNCES (425 G)) CHICKPEAS
- 1/2 TEASPOON (2 ML) KOSHER SALT
- 1/4 TEASPOON (1 ML) FRESHLY GROUND BLACK PEPPER
- 3 TABLESPOONS (45 ML) HERBED VINAIGRETTE (PAGE 7)

Makes 10 cups (2.5 L)

Approximate preparation time: 20 to 25 minutes, including vinaigrette

Insert the large metal chopping blade into the large work bowl of the Cuisinart® Food Processor. Add the celery, carrots, onion, parsley and scallions and pulse to chop, about 10 pulses. Remove and place vegetables into a large mixing bowl. Add the cucumber to the work bowl and pulse to roughly chop, 5 pulses, and add to mixing bowl. Roughly chop the tomatoes by pulsing them with 5 pulses and add to the mixing bowl with the corn and chickpeas. Toss all ingredients together with salt, pepper and vinaigrette. Taste and adjust seasoning accordingly. Serve immediately.

Nutritional information per serving (1 cup (250 ml)):

Calories 140 (28% from fat) | carb. 23g | pro. 5g | fat 5g | sat. fat 1g | chol. 0mg | sod. 342mg | calc. 53mg | fiber 5g

CLASSIC COLESLAW

The Cuisinart® Food Processor makes the preparation of this picnic favourite a breeze.



- 1/2 HEAD GREEN CABBAGE, CORED AND QUARTERED
- 1/2 HEAD RED CABBAGE, CORED AND HALVED
- 1/2 POUND (250 G) CARROTS
- 1/2 FENNEL BULB
- 1 1/4 TEASPOONS (6 ML) KOSHER SALT
- 1/2 CUP (125 ML) MAYONNAISE
- 1/2 TEASPOON (2 ML) FRESHLY GROUND BLACK PEPPER
- 1/4 TEASPOON (1 ML) GRANULATED SUGAR

Makes 8 cups (2 L)

Approximate preparation time: 5 to 10 minutes, plus 1 hour for resting time

Insert the slicing disc assembly, adjusted to 4mm, into the large work bowl of the Cuisinart® Food Processor and slice both cabbages. Remove and place in a large mixing bowl. Replace the slicing disc with the reversible shredding disc on the medium shredding side and shred the carrots and fennel. Toss well with the cabbage and the salt. Let vegetables sit for 1 hour and then squeeze out any moisture and drain. Toss with remaining ingredients. Taste and adjust seasoning accordingly.

Nutritional information per serving (1 cup (250 ml)):

Calories 177 (74% from fat) | carb. 10g | pro. 2g | fat 15g | sat. fat 2g | chol. 7mg | sod. 597mg | calc. 65mg | fiber 4g

CLASSIC MEATBALLS

A classic recipe to use for meatballs and meatloaf.



- ½ MEDIUM ONION, ABOUT 1½ OUNCES (43 G), CUT IN QUARTERS
- ¼ CUP (50 ML) LOOSELY PACKED PARSLEY LEAVES
- 1 SLICE DAY-OLD FIRM BREAD, TORN INTO PIECES
- ¾ POUND (375 G) BONELESS CHUCK, CUT INTO 1-INCH (2.5 CM) PIECES
- ¾ POUND (375 G) BONELESS PORK, CUT INTO 1-INCH (2.5 CM) PIECES
- 2½ TABLESPOONS (40 ML) NON-FAT DRY MILK
- 1 TEASPOON (5 ML) KOSHER SALT
- ¾ TEASPOON (3.75 ML) GROUND NUTMEG
- ¼ TEASPOON (1 ML) DRIED THYME
- 1 LARGE EGG
- 2 TABLESPOONS (30 ML) COLD WATER (IF NECESSARY)

Makes approximately 16 meatballs

⌚ Approximate preparation time (meatballs): 10 minutes plus 25 minutes for cooking

⌚ Approximate preparation time (meatloaf): 10 minutes plus 75 minutes for cooking

Insert the large metal chopping blade into the large work bowl of the Cuisinart® Food Processor. Put the onion, parsley, bread, meat, dry milk, salt and spices into the work bowl and pulse 4 to 6 times, then process until finely chopped. Add the eggs and water and pulse until the desired consistency is reached; be careful not to overprocess.

Shape the mixture into balls, 2 tablespoons (30 ml) each. Arrange them in a single layer in a baking dish and bake at 375°F (190°C) for 25 minutes or simmer in tomato sauce until cooked through.

To make meatloaf: Pack the mixture into an 8½ x 4¼ x 3-inch (22 x 11 x 8 cm) loaf pan and bake at 375°F (190°C) for about 75 minutes, until the top is well browned and the internal temperature registers 160°F (71°C).

Nutritional information per serving (1 meatball):

Calories 78 (55% from fat) | carb. 2g | pro. 7g | fat 5g | sat. fat 2g | chol. 31mg | sod. 125mg | calc. 20mg | fiber 0g

Nutritional information per serving (one 1-inch (2.5 cm) slice meatloaf):

Calories 376 (55% from fat) | carb. 10g | pro. 31g | fat 22g | sat. fat 8g | chol. 151mg | sod. 601mg | calc. 95mg | fiber 1g

CHICKEN MARSALA

This elegant meal is easy enough to prepare any night of the week.



- 2 LEEKS, WHITE PARTS ONLY
- 8 OUNCES (227 G) BABY PORTO-BELLO MUSHROOMS
- 3½ OUNCES (100 G) SHIITAKE MUSHROOMS
- 8 OUNCES (227 G) CREMINI MUSHROOMS
- ¼ CUP (50 ML) MARSALA WINE
- ½ CUP (125 ML) CHICKEN OR BEEF BROTH
- 2 TABLESPOONS (30 ML) CORNSTARCH
- 3 TABLESPOONS (45 ML) UNSALTED BUTTER, DIVIDED
- 1 TEASPOON (5 ML) KOSHER SALT, DIVIDED
- ½ TEASPOON (2 ML) FRESHLY GROUND PEPPER, DIVIDED
- 2½ POUNDS (1.1 KG) CHICKEN BREAST, THINLY SLICED
- ¼ CUP (50 ML) UNBLEACHED, ALL-PURPOSE FLOUR

Makes 8 servings

⌚ Approximate preparation time: 30 to 35 minutes

Insert the slicing disc assembly, adjusted to 2mm, into the large work bowl of the Cuisinart® Food Processor, and slice the leeks. Remove and wash well in cold water to remove any dirt; dry well. Rinse the work bowl of any dirt from the leeks. Adjust the slicing disc to 6mm and slice the mushrooms. Remove and reserve. Replace the slicing disc with the large metal chopping blade and process the Marsala, broth and cornstarch together; reserve.

Put 1 tablespoon (15 ml) of butter into a large skillet over medium heat. When butter melts, add the leeks, mushrooms, ½ teaspoon (2 ml) of salt, and ¼ teaspoon (1 ml) of pepper to the skillet. Stir vegetables and sauté until very soft, about 8 to 10 minutes; reserve.

While vegetables are cooking, sprinkle the chicken on both sides with remaining salt and pepper. Dredge in flour, tapping away any excess flour. Add remaining butter to the skillet and sauté chicken until golden on both sides, about 3 to 5 minutes on each side; remove and reserve. Return the mushroom mixture to the skillet and add the Marsala mixture; bring to a simmer until the sauce thickens, about 4 minutes. Taste and adjust seasoning accordingly. Return the chicken to the skillet to heat through in the simmering sauce. Serve immediately.

Nutritional information per serving:

Calories 252 (22% from fat) | carb. 12g | pro. 35g | fat 6g | sat. fat 3g | chol. 93mg | sod. 446mg | calc. 33mg | fiber 1g

CRAB CAKES

A delicious treat that is easy to make for any occasion.



- 16 OUNCES (454 G) LUMP CRABMEAT
- 1 GARLIC CLOVE
- 1 RED BELL PEPPER, ABOUT 7 OUNCES (200 G), CUT INTO 2-INCH (5 CM) PIECES
- 3 GREEN ONIONS, CUT INTO 1-INCH (2.5 CM) PIECES
- ½ CUP (125 ML) PARSLEY
- 1 TEASPOON (5 ML) EXTRA VIRGIN OLIVE OIL
- ¼ TEASPOON (1 ML) KOSHER SALT
- ¼ TEASPOON (1 ML) FRESHLY GROUND PEPPER
- 2 LARGE EGGS, LIGHTLY BEATEN
- 1 CUP (250 ML) BASIC FRESH BREADCRUMBS (PAGE 5)
- ½ CUP (125 ML) MAYONNAISE
- 1 TEASPOON (7 ML) WORCESTERSHIRE SAUCE
- 1½ TEASPOONS (7 ML) OLD BAY SEASONING
- 2 TEASPOONS (10 ML) DIJON-STYLE MUSTARD
- HOT SAUCE, OPTIONAL

Makes twelve 3-ounce (85 g) cakes

⌚ Approximate preparation time: 10 minutes plus 20 minutes cooking time

Look through crabmeat to make sure there are no shells; reserve in refrigerator. Preheat oven to 400°F (200°C). Coat a baking sheet with nonstick cooking spray.

Insert the large metal chopping blade into the large work bowl of the Cuisinart® Food Processor. With the machine running, drop the garlic through the small feed tube to chop. Add the peppers, green onion and parsley and pulse to coarsely chop, about 10 to 12 pulses.

Put the oil into a large skillet placed over medium heat. Cook chopped vegetables with salt and pepper until soft, about 5 to 7 minutes. Remove and reserve in a large mixing bowl.

Once vegetables have cooled slightly, add the crab, eggs, breadcrumbs, mayonnaise, Worcestershire, Old Bay, Dijon and a dash or two of hot sauce if using to the mixing bowl. Mix thoroughly but carefully, so not to break up the crab too much. Form mixture into 2-inch (5 cm) round cakes.

Place on prepared baking sheet and bake until crabcakes are evenly golden, about 15 to 20 minutes.

TIP: Substitute cooked fish fillet for the crab to make tasty fishcakes.

Nutritional information per serving (2 crab cakes):

Calories 123 (33% from fat) | carb. 11g | pro. 11g | fat 5g | sat. fat 2g | chol. 77mg | sod. 912mg | calc. 54mg | fiber 1g

STUFFED ROASTED PEPPERS

These hearty peppers can also be served as a main course, and are delicious with our Simple Tomato Sauce.



- 3 NONSTICK COOKING SPRAY
- ½ GARLIC CLOVES
- ½ LARGE RED ONION, CUT INTO 1-INCH (2.5 CM) PIECES
- 1½ TABLESPOONS (25 ML) NONFAT DRIED MILK
- 1 TABLESPOON (15 ML) FRESH ITALIAN PARSLEY
- ¾ TEASPOON (3.75 ML) DRIED BASIL
- ¾ TEASPOON (3.75 ML) CELERY SEED
- 1½ TEASPOONS (7 ML) KOSHER SALT
- ½ TEASPOON (2 ML) FRESHLY GROUND BLACK PEPPER
- 1¾ POUNDS (795 G) PORK SHOULDER, CUT INTO 1-INCH (2.5 CM) PIECES
- 2 TABLESPOONS (30 ML) OLIVE OIL
- 3¾ OUNCES (100 G) BASIC FRESH BREADCRUMBS, ABOUT 1 CUP (250 ML) (PAGE 5)
- 1 LARGE EGG
- 6 TO 8 MEDIUM MULTI-COLOURED PEPPERS, CORED WITH SEEDS REMOVED

Makes 6 to 8 peppers

⌚ Approximate preparation time: 65 to 70 minutes, including bake time

Preheat oven to 325°F (160°C). Lightly coat a 13 x 9-inch (33 x 23 cm) pan with nonstick cooking spray.

Insert the large metal chopping blade into the large work bowl of the Cuisinart® Food Processor. With the machine running, drop the garlic through the feed tube to chop. Add the onion, dried milk, parsley, basil, celery seed, salt, and pepper; pulse to chop, about 10 pulses. Then run machine to finely chop, about 35 seconds. Remove and reserve.

Add the pork to the work bowl and pulse 10 times, then run machine to finely chop, about 35 seconds.

Put the olive oil into large skillet over medium heat. Once oil is heated, add the onion mixture to the skillet; cook until softened, about 5 minutes. Stir in the pork and cook until cooked through, about 10 to 15 minutes; reserve. Stir the breadcrumbs into meat mixture with eggs; combine mixture well. Evenly fill the peppers and place in prepared pan. Bake peppers in oven until soft and lightly browned, about 40 to 45 minutes.

Nutritional information per serving:

Calories 324 (42% from fat) | carb. 20g | pro. 27g | fat 15g | sat. fat 4g | chol. 120mg | sod. 631mg | calc. 81mg | fiber 3g

MASHED POTATOES

Try this rich but not too sinful version of the traditional mashed potatoes.



- 2½ POUNDS (1.1 KG) YUKON GOLD POTATOES, PEELED AND CUT INTO 1-INCH (2.5 CM) PIECES
- 10 CHIVES, TRIMMED, DRIED WELL AND CUT INTO 1-INCH (2.5 CM) PIECES
- 1 OUNCE (30 G) PARMESAN, CUT INTO ½-INCH (1.25 CM) PIECES
- 3 TABLESPOONS (45 ML) UNSALTED BUTTER
- ½ TEASPOON (2 ML) KOSHER SALT
- ½ TEASPOON (2 ML) FRESHLY GROUND BLACK PEPPER
- ½ CUP (125 ML) WHOLE MILK
- ½ CUP (125 ML) MASCARPONE CHEESE

Makes 5 cups (1.25 L), ten ½-cup (125 ml) servings

⌚ Approximate preparation time: 35 minutes

Put the potatoes into a large saucepan and cover with water. Bring to a boil and simmer until potatoes are tender.

Insert the small metal chopping blade into the small work bowl of the Cuisinart® Food Processor. Add the chives and pulse to finely chop; remove work bowl and reserve.

Insert the reversible shredding disc on the fine shredding side into the large work bowl of the Cuisinart® Food Processor and shred the Parmesan. Reverse the disc to the medium shredding side. Once the potatoes are tender, shred the potatoes. Replace the shredding disc with the large metal chopping blade. Add the butter, salt, and pepper and pulse to combine. Add the milk through the feed tube while pulsing, until incorporated. Add the mascarpone and chives and pulse until just combined. Taste and adjust seasoning accordingly.

Nutritional information per serving:

Calories 160 (35% from fat) | carb. 21g | pro. 5g | fat 6g | sat. fat 4g | chol. 18mg | sod. 211mg | calc. 75mg | fiber 3g

CLASSIC CUISINART® WHITE BREAD

Spoil your family with homemade bread.



- 2¼ TEASPOONS (11 ML) ACTIVE DRY YEAST
- 1 TABLESPOON (15 ML) GRANULATED SUGAR
- ⅓ CUP WARM WATER (105° TO 110°F (40° TO 43°C))
- 5 CUPS (1.25 L) UNBLEACHED, ALL-PURPOSE FLOUR
- 4 TABLESPOONS (60 ML) (¼ POUND (125 G); ½ STICK) UNSALTED BUTTER, CUT INTO 1-INCH (2.5 CM) PIECES
- 2 TEASPOONS (10 ML) SALT
- 1⅓ CUPS (325 ML) COLD WATER
- NONSTICK COOKING SPRAY

Makes 18 servings (two 9 x 5-inch (23 x 13 cm) loaves, 1¼ pounds (625 g) each)

⌚ Approximate preparation time: 10 to 15 minutes, plus 2½ hours rising and resting, 35 minutes baking, and 1 hour or longer cooling

Dissolve the yeast and sugar in warm water in a large liquid measuring cup. Let sit until foamy, about 5 minutes.

Insert the dough blade into the large work bowl of the Cuisinart® Food Processor. Add the flour, butter and salt and process until combined, about 10 to 15 seconds. Add the cold water to yeast mixture. With the machine running, pour the liquid through the feed tube as fast as the flour absorbs it. Once the dough cleans the sides of the work bowl and forms a ball, process for 45 seconds to knead the dough. Dough should be smooth and elastic.

Place the dough in a lightly floured plastic food storage bag and seal. Allow to rest in a warm place until doubled in size, about 1 to 1½ hours.

Lightly coat two 9 x 5-inch (23 x 13 cm) loaf pans with nonstick cooking spray. Place dough on a lightly floured surface and punch down; let rest 5 to 10 minutes. Divide dough into two equal pieces and shape each into a loaf. Place in prepared pans and cover lightly with plastic wrap. Let rise until dough is just above the tops of the pans, about 45 minutes to 1 hour.

Preheat oven to 400°F (200°C).

Bake until the tops are browned and loaf sounds hollow when tapped, about 30 to 35 minutes. Remove from pans and cool on wire rack.

Nutritional information per slice:

Calories 139 (19% from fat) | carb. 25g | pro. 3g | fat 3g | sat. fat 2g | chol. 8mg | sod. 243mg | calc. 30mg | fiber 1g

CLASSIC CUISINART® WHEAT BREAD

The nutty flavour of whole wheat makes this bread a favourite.



- 2¼ TEASPOONS (11 ML) ACTIVE DRY YEAST
- 1 TABLESPOON (15 ML) PLUS 1 TEASPOON (5 ML) GRANULATED SUGAR
- ⅓ CUP (75 ML) WARM WATER (105° TO 110°F (40° TO 43°C))
- 2 CUPS (500 ML) UNBLEACHED, ALL-PURPOSE FLOUR
- 2 CUPS (500 ML) WHOLE WHEAT FLOUR
- 4 TABLESPOONS (60 ML) UNSALTED BUTTER, CUT INTO 1-INCH (2.5 CM) PIECES
- ½ TABLESPOON (7 ML) SALT
- 1 CUP (250 ML) COLD WATER
- NONSTICK COOKING SPRAY

Makes 12 servings (one 9 x 5-inch (23 x 13 cm) loaf)

⌚ Approximate preparation time: 10 to 15 minutes, plus 2½ hours rising and resting, 35 minutes baking, and 1 hour or longer cooling

Dissolve the yeast and sugar in warm water in a large liquid measuring cup. Let sit until foamy, about 5 minutes.

Insert the dough blade into the large work bowl of the Cuisinart® Food Processor. Add the flours, butter and salt and process until combined, about 10 to 15 seconds. Add the cold water to the yeast mixture. With the machine running, pour the liquid through the feed tube as fast as the flour absorbs it. Once the dough cleans the sides of the work bowl and forms a ball, process for 45 seconds to knead dough. Dough should be smooth and elastic.

Place the dough in a lightly floured plastic food storage bag and seal. Allow to rest in a warm place until doubled in size, about 1 to 1½ hours.

Lightly coat a 9 x 5-inch (23 x 13 cm) loaf pan with nonstick cooking spray. Place dough on a lightly floured surface and punch down; let rest 5 to 10 minutes. Shape the dough into a loaf. Place in prepared pan and cover lightly with plastic wrap. Let rise until dough is just above the tops of the pans, about 45 minutes to 1 hour.

Preheat oven to 400°F (200°C).

Bake until the top is browned and loaf sounds hollow when tapped, about 30 to 35 minutes. Remove from pan and cool on wire rack.

Nutritional information per serving (1 slice):

Calories 135 (20% from fat) | carb. 23g | pro. 4g | fat 3g | sat. fat 2g | chol. 8mg | sod. 244mg | calc. 30mg | fiber 3g

BUTTERY DINNER ROLLS

Fresh from the oven, warm rolls make any dinner extra special.



- ¾ CUP (175 ML) WHOLE MILK, PLUS 1 TABLESPOON (15 ML) FOR BRUSHING
- ½ CUP (125 ML) UNSALTED BUTTER, PLUS 2 TABLESPOONS (30 ML) FOR BRUSHING
- ¼ CUP (50 ML) GRANULATED SUGAR
- 1 TEASPOON (5 ML) FINE SEA SALT, OR TABLE SALT
- 2¼ TEASPOONS (11 ML) ACTIVE DRY YEAST
- ¼ CUP (50 ML) WARM (105° TO 110°F (40° TO 43°C)) WATER
- 4¾ CUPS (1.18 L) UNBLEACHED BREAD FLOUR
- 1 LARGE EGG

Makes 16 rolls

⌚ Approximate preparation time: 20 to 25 minutes, plus 2½ hours rising, 40 minutes baking, and 10 to 15 minutes cooling.

In a microwave-safe container, scald the milk in the microwave; stir in the butter, sugar and salt; reserve.

Dissolve the yeast in the warm water. Let stand 3 to 5 minutes, or until mixture is foamy. Put the flour into the large work bowl of the Cuisinart® Food Processor fitted with the dough blade and process for 10 seconds. With the machine running, slowly add the liquids through the feed tube and process until a dough ball forms. Continue processing 45 seconds to knead the dough. Shape it into a smooth ball and place in a 1-gallon (3.8 L) sealable plastic bag. Squeeze the air out and seal the bag. Let rise in a warm place until it has doubled, about 45 to 60 minutes.

Preheat oven to 450°F (230°C). Lightly butter a 10-inch (25 cm) round baking pan. Divide the dough into 16 equal pieces, (about 2¼ ounces (65 g) each). Roll into smooth rounds and arrange in the prepared pan. Cover with plastic wrap and let rise until about doubled, about 30 to 40 minutes. Combine remaining tablespoon of milk and butter and heat until the butter has melted. Just before baking, gently brush the rolls with the butter/milk mixture. Place in preheated oven and bake until golden brown, about 25 to 30 minutes. Remove from pan and let cool on a rack for about 10 minutes for serving.

For a softer roll, brush each with melted butter just after removing from oven.

Nutritional information per serving (1 roll):

Calories 209 (38% from fat) | carb. 28g | pro. 5g | fat 9g | sat. fat 5g | chol. 34mg | sod. 160mg | calc. 23mg | fiber 1g

POPOVERS

Eat the popovers hot out of the oven to fully appreciate their delicious texture.



- 1½ CUPS (375 ML) UNBLEACHED, ALL-PURPOSE FLOUR
- ¾ CUP (175 ML) PLUS 4 TEASPOONS (20 ML) EVAPORATED MILK
- 2 LARGE EGGS
- 1 TABLESPOON (15 ML) UNSALTED BUTTER, MELTED
- ½ TEASPOON (2 ML) SALT BUTTER OR NONSTICK COOKING SPRAY FOR PAN

Makes 12 popovers

⌚ Approximate preparation time: 5 minutes plus 45 minutes for resting and 50 minutes for baking

Insert the large metal chopping blade into the large work bowl of the Cuisinart® Food Processor. Add the flour, milk, eggs, butter and salt and process ingredients together until completely smooth, about 20 to 30 seconds. Transfer to a large measuring cup and allow to rest at room temperature for about 30 to 45 minutes.

Preheat oven to 450°F (230°C) (use convection bake if available). Heavily butter or coat with nonstick cooking spray two 6-cup (1.5 L) popover pans or twelve 5-ounce (145 g) ramekins or muffin cups and place on two baking sheets. Fill each cup/ramekin with about ⅓ cup (75 ml) of batter. Place in oven and bake for 30 minutes. Lower the heat to 350°F (180°C) and bake for an additional 20 minutes. Remove from oven and carefully remove popovers from ramekins. Serve immediately.

Nutritional information per popover:

Calories 136 (39% from fat) | carb. 14g | pro. 6g | fat 6g | sat. fat 3g | chol. 87mg | sod. 188mg | calc. 98mg | fiber 0g

CLASSIC CHEESECAKE

This simple recipe produces perfect cheesecake every time.



- 1 BUTTER TO PREPARE THE PAN RECIPE GRAHAM CRACKER CRUST (BELOW)
- 24 OUNCES (680 G) CREAM CHEESE, ROOM TEMPERATURE
- 1½ CUPS (375 ML) GRANULATED SUGAR
- ½ TEASPOON (2 ML) SALT
- 4 LARGE EGGS, ROOM TEMPERATURE
- 1 TEASPOON (5 ML) PURE VANILLA EXTRACT
- ¾ CUP (175 ML) RICOTTA, ROOM TEMPERATURE
- ¾ CUP (175 ML) SOUR CREAM, ROOM TEMPERATURE

Makes one 9-inch (23 cm) cake, 12 servings

⌚ Approximate preparation time: 15 minutes, plus 3 hours baking/resting and 6-plus hours cooling

Preheat oven to 325°F (160°C). Place a large roasting pan on bottom rack of oven and fill with 1 to 2 inches (2.5 to 5 cm) of water.

Butter one 9-inch (23 cm) springform pan.

Prepare the graham cracker crust according to recipe below.

Press the graham cracker crust evenly into the prepared pan.

Insert the large metal chopping blade into the large work bowl of the Cuisinart® Food Processor. Cut each block of cream cheese into 6 pieces and place into the work bowl; pulse 10 times and then process for 45 seconds. Scrape the bowl and add the sugar and salt; process for an additional 30 to 45 seconds until smooth. With the machine running, add the eggs one at a time with the vanilla, until just incorporated. Add the ricotta and sour cream and pulse until all ingredients are just incorporated and homogenous, scraping the bowl as necessary.

Pour filling evenly into the prepared pan and bake in the middle of the oven. Add more water to roasting pan if any has evaporated. Bake for 1 hour. Turn the oven off and let the cake rest in the oven. Do not open the oven door until 2 hours have elapsed.

Remove cheesecake and place on a cooling rack. Once completely cool, wrap well with plastic and refrigerate for at least 6 hours before serving.

Serve with fresh berries and Raspberry Sauce (page 46).

Nutritional information per serving:

Calories 456 (60% from fat) | carb. 38g | pro. 8g | fat 31g | sat. fat 18g | chol. 154mg | sod. 391mg | calc. 72mg | fiber 1g

GRAHAM CRACKER CRUST

Makes one 9-inch (23 cm) pie crust, 12 servings

⌚ Approximate preparation time: 2 minutes

Insert the large metal chopping blade into the large work bowl of the Cuisinart® Food Processor. Break crackers in fours and place in the work bowl; pulse until finely chopped, about 10 to 12 long pulses. Add the cinnamon and sugar and process for 15 seconds. Add the butter and process until ingredients are well combined, about 45 seconds.

Press even amounts of crust into a 9-inch (23 cm) pie or cake plate.

Nutritional information per serving:

Calories 78 (44% from fat) | carb. 10g | pro. 1g | fat 4g | sat. fat 2g | chol. 8mg | sod. 64mg | calc. 4mg | fiber 0g



- ½ OUNCES (15 G) GRAHAM CRACKERS, ABOUT 1 SLEEVE
- ½ TEASPOON (2 ML) GROUND CINNAMON
- 2 TABLESPOONS (30 ML) GRANULATED SUGAR
- 3 TABLESPOONS (45 ML) UNSALTED BUTTER, MELTED

APPLE CRUMB PIE

The adjustable slicing disc makes preparing this pie a breeze.



- ½ RECIPE SWEET PÂTE BRISÉE DOUGH (PAGE 15)
- 5 LARGE APPLES (GOLDEN DELICIOUS, GINGER GOLD, OR OTHER SIMILAR APPLES), PEELED, CORED AND HALVED
- JUICE OF 2 LEMONS
- 1 TEASPOON (5 ML) VANILLA PASTE
- ½ CUP (125 ML) GRANULATED SUGAR
- 2 TABLESPOONS (30 ML) APRICOT JAM
- 1 RECIPE CRUMB PIE TOPPING (BELOW)

Makes one 9-inch (23 cm) deep-dish pie, 8 to 12 servings

⌚ Approximate preparation time: 55 to 65 minutes, including baking time

Preheat oven to 350°F (180°C).

Roll out dough into a 10-inch (25 cm) disc. Fit into an ungreased, 9-inch (23 cm), 1½-quart (1.4 L) ceramic pie baker.

Chill in refrigerator for about 20 minutes.

Insert the slicing disc assembly, adjusted to 4mm, into the large work bowl of the Cuisinart® Food Processor and slice the apples.

In a large bowl, toss the apples, lemon juice, vanilla paste, and sugar together. Carefully spread the jam on the bottom of the chilled pie shell, then fan the apples in layers.

Top the pie evenly with the crumb topping and bake for 40 to 50 minutes, or until the top of the pie is a dark golden brown.

Nutritional information per serving (based on 12 servings):
Calories 166 (8% from fat) | carb. 36g | pro. 3g | fat 1g | sat. fat 0g | chol. 36mg | sod. 225mg | calc. 10mg | fiber 2g

CRUMB PIE TOPPING

Pair this topping with our Apple Crumb recipe, or any fruit-filled pie.



- ⅓ CUP (75 ML) TOASTED PECANS
- ¾ CUP (175 ML) UNBLEACHED, ALL-PURPOSE FLOUR
- ⅓ CUP (175 ML) UNSALTED BUTTER, COLD AND CUT INTO CUBES
- 1¼ TEASPOONS (6 ML) GROUND CINNAMON
- ¼ TEASPOON (1 ML) SALT

Makes enough crumb topping for one pie

⌚ Approximate preparation time: 3 minutes

Insert the small metal chopping blade into the small work bowl of the Cuisinart® Food Processor. Add the pecans and pulse to roughly chop. Add remaining ingredients and pulse until mixture is well combined – mixture should resemble crumbs.

Nutritional information per serving (based on 12 servings):
Calories 89 (69% from fat) | carb. 6g | pro. 1g | fat 7g | sat. fat 3g | chol. 13mg | sod. 44mg | calc. 5mg | fiber 1g

BANANA CREAM PIE

Everyone will love this Southern-inspired dessert.



- 1 RECIPE CHOCOLATE COOKIE CRUST (BELOW)
- 4 MEDIUM BANANAS
- ¼ TEASPOON (1 ML) GROUND CINNAMON
- 1 RECIPE LIGHTER PASTRY CREAM (PAGE 44)

Makes one 9-inch (23 cm) pie

⌚ Approximate preparation time: 50 minutes, including pastry cream; allow 2 hours for chilling

Preheat oven to 375°F (190°C).

Prepare chocolate cookie crust according to recipe.

Press cookie crust into a 9-inch (23 cm) pie plate and bake for 15 minutes.

Insert the slicing disc assembly, adjusted to 4mm, into the large work bowl of the Cuisinart® Food Processor and slice the bananas.

Gently fold the bananas and cinnamon into the prepared lighter pastry cream. Pour the banana pastry cream into the baked, cooled cookie crust and chill for at least 2 hours before serving.

Nutritional information per serving:

Calories 315 (52% from fat) | carb. 35g | pro. 4g | fat 19g | sat. fat 11g | chol. 111mg | sod. 177mg | calc. 61mg | fiber 2g

CHOCOLATE COOKIE CRUST

We love this with our Banana Cream Pie, but it also makes a cheesecake even more decadent.



- 24 CHOCOLATE WAFERS, ABOUT ½ BOX
- 2 TEASPOONS GRANULATED SUGAR
- ¼ CUP (50 ML) UNSALTED BUTTER, MELTED

Makes 1 cup (250 ml), 12 servings

⌚ Approximate preparation time: 1 minute plus 15 minutes for baking time

Insert the large metal chopping blade into the large work bowl of the Cuisinart® Food Processor. Add the cookies and pulse 10 times. Add the sugar and pulse an additional 5 times. With the machine running, drizzle in the melted butter until incorporated.

Press crust into a 9-inch (23 cm) pie or cake plate and bake in a 375°F (190°C) oven for 15 minutes before filling.

Nutritional information per serving:

Calories 85 (55% from fat) | carb. 9g | pro. 1g | fat 5g | sat. fat 3g | chol. 10mg | sod. 65mg | calc. 3mg | fiber 0g

PASTRY CREAM

This all-purpose pastry cream is a great foundation for fresh fruit tarts – the food processor makes it easy.



- 1½ CUPS (375 ML) MILK
- ½ CUP (125 ML) HEAVY CREAM
- ½ CUP (125 ML) GRANULATED SUGAR, DIVIDED
- ½ TEASPOON (2 ML) SALT
- ½ TABLESPOON (7 ML) PURE VANILLA EXTRACT
- 4 LARGE EGG YOLKS
- 2 TABLESPOONS (30 ML) CORNSTARCH

FOR A LIGHTER PASTRY CREAM:

- ½ CUP (125 ML) HEAVY CREAM
- 1½ TABLESPOONS (25 ML) CONFECTIONERS' SUGAR

Makes about 2¼ (550 ml) cups

Approximate preparation time: 25 minutes, including cooking time

Put the milk, cream, ¼ cup (50 ml) sugar, salt and vanilla into a saucepan over medium heat. Bring mixture to a heavy simmer.

Insert the large metal chopping blade into the large work bowl of the Cuisinart® Food Processor. Add the yolks, cornstarch and remaining sugar, process for 1 minute until mixture is light and thick.

With the machine running, pour ¾ to 1½ cups (175 to 375 ml) of the milk mixture slowly through the feed tube and process mixture for about 1 minute.

Return mixture to the saucepan over medium heat. Bring to a boil and cook while whisking continuously for about 2½ minutes until thickened. Strain mixture through a fine mesh strainer into the large work bowl fitted with the large metal chopping blade. Process for 5 minutes. Pour mixture into a clean mixing bowl and cover directly with plastic wrap and cool before using.

For a lighter pastry cream: whip the ½ cup (125 ml) of heavy cream to medium peaks with 1½ tablespoons (25 ml) of confectioners' sugar. Fold the sweetened whipped cream into the pastry cream once completely cool.

Nutritional information per serving (2 tablespoons (30 ml)):
Calories 72 (50% from fat) | carb. 8g | pro. 1g | fat 4g | sat. fat 2g | chol. 58mg | sod. 72mg | calc. 32mg | fiber 0g

DEEP CHOCOLATE LAYER CAKE

Frost this deep and rich chocolate cake with Cream Cheese Frosting (below).



- 2 CUPS (500 ML) UNBLEACHED, ALL-PURPOSE FLOUR
- ¾ TEASPOON (3.75 ML) BAKING SODA
- ½ TEASPOON (2 ML) BAKING POWDER
- ½ TEASPOON (2 ML) SALT
- ¾ CUP (175 ML) GRANULATED SUGAR
- ¾ CUP (175 ML) BROWN SUGAR
- 5 OUNCES (145 G) BITTERSWEET CHOCOLATE, CHOPPED
- ¾ CUP (175 ML) UNSWEETENED COCOA POWDER
- ½ TABLESPOON (7 ML) ESPRESSO POWDER
- 1 CUP (250 ML) BOILING WATER
- 1 CUP (250 ML) (½ POUND (250 G) ; 2 STICKS) UNSALTED BUTTER, MELTED AND COOLED
- ¾ CUP (175 ML) BUTTERMILK
- 3 LARGE EGGS
- ½ TABLESPOON (7 ML) PURE VANILLA EXTRACT

Makes two 9-inch (23 cm) cakes (one 2- or 4-layer cake), 12 servings

Approximate preparation time: 15 minutes, plus 50 minutes to bake, plus cooling time

Preheat oven to 350°F (180°C). Coat two 9-inch (23 cm) round pans with butter and cut rounds of parchment paper to fit the bottoms of each pan.

Insert the large metal chopping blade into the large work bowl of the Cuisinart® Food Processor. Add the flour, baking soda, baking powder, salt and sugars and pulse 10 times and then process for 20 seconds to sift.

Place the bittersweet chocolate, cocoa powder and espresso powder into a small bowl and pour the boiling water over ingredients and stir to combine; reserve.

With the machine running, slowly pour the butter through the feed tube. Continue pouring the buttermilk, eggs, and vanilla through the feed tube until ingredients are just combined. Pour the chocolate mixture evenly over the batter and pulse to completely incorporate.

Divide the batter evenly between the two prepared pans. Bake in oven for 45 to 50 minutes, until a cake tester comes out just clean.

Let pans rest on cooling racks for 15 minutes. Remove cake from pans but leave on the racks until completely cool. Once cool, cut each layer in half horizontally to frost with Cream Cheese Frosting and build a four-layer cake, or leave the layers as is and make a thick two-layer cake.

Nutritional information per serving:

Calories 258 (23% from fat) | carb. 49g | pro. 6g | fat 7g | sat. fat 3g | chol. 54mg | sod. 224mg | calc. 38mg | fiber 3g

CREAM CHEESE FROSTING



- 24 OUNCES (680 G) CREAM CHEESE (ROOM TEMPERATURE), EACH PACKAGE OF CREAM CHEESE CUT INTO 6 PIECES
- 1½ CUPS (375 ML) (¾ POUND (375 G) ; 3 STICKS) UNSALTED BUTTER, ROOM TEMPERATURE
- 1⅓ CUPS (400 ML) CONFECTIONERS' SUGAR, SIFTED
- ¾ TEASPOON (3.75 ML) SALT
- 1 TEASPOON (5 ML) PURE VANILLA EXTRACT
- 2 TEASPOONS (10 ML) SOUR CREAM

Makes about 4¼ (1 L) cups

Approximate preparation time: 10 minutes

Insert the large metal chopping blade into the large work bowl of the Cuisinart® Food Processor. Add the cream cheese, butter, sugar and salt; pulse 2 to 3 times and then process until smooth. Add the vanilla and sour cream and pulse to combine.

Nutritional information per serving (1 tablespoon (15 ml)):

Calories 84 (81% from fat) | carb. 3g | pro. 1g | fat 8g | sat. fat 5g | chol. 23mg | sod. 57mg | calc. 8mg | fiber 0g

DESSERT CRÊPES WITH BERRIES

Crêpe-making takes some practice, but once you get the technique down it is all worth it.



SWEET CRÊPE BATTER:

- 3 LARGE EGGS
- ¾ CUP (175 ML) UNBLEACHED, ALL-PURPOSE FLOUR
- ½ TEASPOON (2 ML) SALT
- 2 TABLESPOONS (30 ML) GRANULATED SUGAR
- 1 TEASPOON (5 ML) PURE VANILLA EXTRACT
- 1 CUP (250 ML) WHOLE MILK
- ¼ CUP (50 ML) (½ STICK) UNSALTED BUTTER, MELTED

BERRIES:

- 2 CUPS (500 ML) MIXED FRESH BERRIES
- ¼ TEASPOON (1 ML) ORANGE ZEST
- 2 TEASPOONS (10 ML) GRANULATED SUGAR

MASCARPONE CREAM:

- 8 OUNCES (227 G) MASCARPONE
- ¾ CUP (175 ML) HEAVY CREAM
- ⅓ CUP (75 ML) SUPERFINE SUGAR
- 1 TEASPOON (5 ML) PURE VANILLA EXTRACT
- PINCH SALT
- ¼ TEASPOON (1 ML) ORANGE ZEST
- 1 TEASPOON (5 ML) UNSALTED BUTTER
- CONFECTIONERS' SUGAR FOR DUSTING

Makes 6 servings

Approximate preparation time: 25 minutes, not including resting the batter

Insert the large metal chopping blade into the large work bowl of the Cuisinart® Food Processor. With the machine running, add the eggs to the work bowl. Stir together the flour, salt and sugar and add to the work bowl and mix until just combined. With the machine running, add the vanilla, milk and butter together and process until homogenous. Transfer mixture to a container; cover and let rest in the refrigerator for 2 hours or overnight.

Insert the small metal chopping blade into the small work bowl and add the berries, orange zest and sugar. Process until completely puréed. Strain the purée through a fine mesh strainer and discard the seeds; reserve.

Insert the large metal chopping blade into the clean large work bowl and add the mascarpone cream ingredients; process until all ingredients are well incorporated, about 15 seconds. Reserve.

Prepare the crêpes. Place an 8-inch (20 cm) skillet over medium heat and preheat for 5 minutes. Once the pan is heated, add the butter. Once melted, wipe the butter around the pan with a paper towel. Add a scant 3 tablespoons (45 ml) of batter to the preheated pan. Working very quickly, move the batter around so it just coats the bottom. You want the pan to be coated thinly and evenly. After about 1 minute, when the crêpe is set and lightly browned, flip the crêpe with a heatproof spatula and cook for an additional minute on the second side. Reserve on a plate. Continue with the remaining batter, stacking the crêpes as you go. When all of the crêpes are prepared, cover plate with foil – to keep crepes warm, place plate over a skillet containing some water over medium-low heat.

To serve crêpes: spread 1½ tablespoons (25 ml) of mascarpone cream and about 1 tablespoon (15 ml) of the puréed berries on each crêpe and fold into thirds. Place three crêpes on each plate and dust with confectioner's sugar and reserved berry purée.

Nutritional information per serving:

Calories 393 (56% from fat) | carb. 35g | pro. 9g | fat 25g | sat. fat 15g | chol. 172mg | sod. 342mg | calc. 98mg | fiber 1g

RASPBERRY SAUCE

This raspberry sauce works well with many desserts – pair it with the dessert crêpes and the cheesecake.



Makes 2 cups (500 ml)

Approximate preparation time: 5 minutes

- 3 CUPS (750 ML) FROZEN RASPBERRIES, THAWED
- 1 CUP (250 ML) FRESH RASPBERRIES
- 2 TABLESPOONS (30 ML) GRANULATED SUGAR
- PINCH SALT
- ¼ TEASPOON (1 ML) ORANGE ZEST

Insert the large metal chopping blade into the large work bowl of the Cuisinart® Food Processor. Add both raspberries and process for 15 seconds. Add remaining ingredients and process for an additional 45 seconds. Strain through a fine mesh strainer and discard the seeds. Taste and adjust sugar amount to personal preference.

Nutritional information per 2 tablespoons (30 ml):
Calories 21 (0% from fat) | carb. 6g | pro. 0g | fat 0g | sat. fat 0g | chol. 0mg | sod. 0mg | calc. 6mg | fiber 2g