

Introduction

Features and Functions

The CLW-SW1 (-SW1) is a stand-alone wall box switch that can also act as a Cresnet® device that reports to a Cresnet® control processor. The -SW1 includes two isolated, non-polarized Cresnet wires (plus a ground wire) for connecting to a Cresnet system over a twisted pair wire with shield.

The CLW-SW1 features a three-position mode selection switch. Refer to “Operating Button and Switch” on page 5 for more information. In the absence of Cresnet communications, the switch can still be used to control a load.

The CLW-SWS1 (-SWS1) is similar to the -SW1 with the added capability of working with a slave unit (CLW-SLVS1) in a multi-switch / single circuit application.

The CLW-SLVS1 (-SLVS1) is a slave unit that when used in conjunction with the -SWS1 acts as an additional switch control point in a multi-switch / single circuit application. It does not connect to a Cresnet system and cannot be used without a -SWS1. The -SLVS1 does not have a mode selection switch and is not programmable. It emulates the operation of the -SWS1 to which it is connected.

The -SW1, -SWS1, and -SLVS1 are available in white, almond, and black. White units are designated by part numbers ending in “W”. Almond units are designated by part numbers ending in “A”. Black units are designated by part numbers ending in “B”. These switches can be covered with a decorative faceplate (not supplied).

Specifications

Following are specifications for the -SW1, -SWS1, and -SLVS1.

CLW-SW1, CLW-SWS1, & CLS-SLVS1 Specifications

SPECIFICATION	DETAILS
Power Requirements	Line Power, 120 VAC, 60 Hz
Default Net ID	SW1: 82 SWS1: 83
Switch Type	Single-Pole, Single-Throw
Load Type	Incandescent, Tungsten Halogen, Fluorescent / High Intensity Discharge (HID), Electronic Low Voltage, Magnetic Low Voltage, Neon / Cold Cathode, General Purpose Fan

(continued on next column)

CLW-SW1, CLW-SWS1, & CLS-SLVS1 Specifications (continued)

SPECIFICATION	DETAILS
2-Series Control System Update File ^{1,2}	Version 3.117 or later
Load Ratings ³	
Incandescent / Tungsten Halogen	-SW1: 1000W -SWS1: 1000W -SLVS1: N/A
Magnetic Low Voltage ⁴	-SW1: 1000VA/750W -SWS1: 1000VA/750W -SLVS1: N/A
Neon / Cold Cathode ⁴	-SW1: 1000VA/750W -SWS1: 1000VA/750W -SLVS1: N/A
Electronic Low Voltage	-SW1: 1000W -SWS1: 1000W -SLVS1: N/A
Fluorescent / High Intensity Discharge (HID)	-SW1: 8A -SWS1: 8A -SLVS1: N/A
General Purpose Fan	-SW1: 3.0A -SWS1: 3.0A -SLVS1: N/A
Minimum Load	40W / 0.5A
Operating Temperature and Humidity	32°F to 104°F (0°C to 40°C) 10 to 90% Relative Humidity (Non-Condensing)
Dimensions and Weight	-SW1 and -SWS1: Height: 4.13 in (10.48 cm) Width: 2.38 in (6.03 cm) Depth: 1.91 in (4.85 cm) Weight: 4.4 oz (0.61 kg) -SLVS1: Height: 4.13 in (10.48 cm) Width: 1.75 in (4.45 cm) Depth: 1.91 in (4.85 cm) Weight: 3.6 oz (0.50 kg)

- The latest versions can be obtained from the Downloads | Software Updates section of the Crestron website (www.crestron.com). Refer to NOTE below.
- Crestron 2-Series control systems include the AV2 and PRO2. Consult the latest Crestron Product Catalog for a complete list of 2-Series control systems.
- Refer to Derating Charts for Multigang Installations on page 3.
- VA ratings are for input power to the transformer. If you do not know the input power requirement of the transformer, use the bulb’s wattage rating to determine proper rating.

NOTE: Crestron software and any files on the website are for Authorized Crestron dealers and Crestron Authorized Independent Programmers (CAIP) only. New users may be required to register to obtain access to certain areas of the site (including the FTP site).

Physical Description

The -SW1 and -SWS1 switch contains one large pushbutton, a light emitting diode (LED) with software adjustable brightness*, and a three-position slider-switch as shown after this paragraph. Line voltage connections are made at the rear of the switch. Three Class 2 low voltage wires, located on the front of the switch, provide a Cresnet connection to a control system. The wires can be routed to the bottom of the unit for placement outside of the wall box. The -SLVS1 is similar to the -SW1 and -SWS1 but does not have the slider-switch or the Class 2 low voltage wires.

* LED brightness can only be adjusted through Crestron programming software.

CLW-SW1/SWS1 (L) and CLW-SLVS1 (R) shown in white



Physical view of CLW-SW1/SWS1 (clockwise from top; Top, Side, and Front)

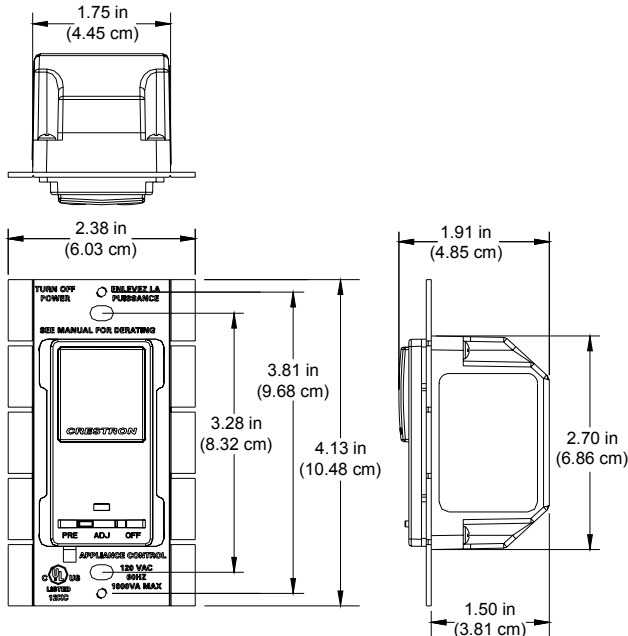

Physical view of CLW-SLVS1 (clockwise from top; Top, Side, and Front)

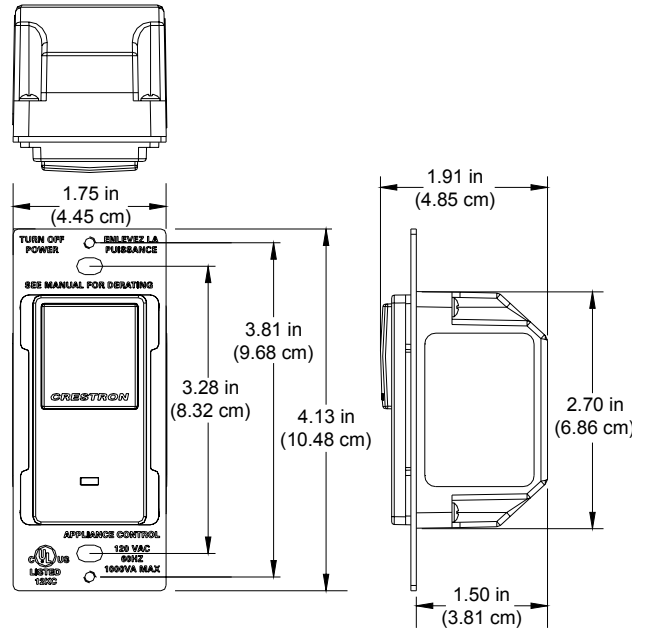

The -SW1, -SWS1, and -SLVS1 mount in a standard wallbox and are covered using a decorative faceplate (not included).

Industry Compliance

This unit has been manufactured to comply with UL's Standards for Safety in Canada and the United States. Formal approval is pending.

Important Notes

Read before installation.

- Codes: Install in accordance with all local and national electrical codes.

Alternate wiring methods may be used for the Class 2 wiring connection. The 2002 National Electrical Code (Article 725-55) prohibits Class 2 conductors of the -SW1, -SWS1, and -SLVS1 to occupy the same outlet box as the power conductors. The exception is Part D of Section 725.55 of the 2002 National Electrical Code, which allows a device's power conductors to be installed near (0.25 inch minimum spacing) associated Class 2 conductors in the same outlet box. Consult the 2002 National Electrical Code Handbook and your local electrical inspector before proceeding.

Do not use the supplied butt-splice connectors if the Class 2 conductors are to be installed in the wallbox with the power conductors. Use

approved connectors (supplied by others) to make Class 2 connections inside the wallbox.

- **CAUTION:** TO REDUCE THE RISK OF OVERHEATING AND POSSIBLE DAMAGE TO OTHER EQUIPMENT, DO NOT INSTALL TO CONTROL A RECEPTACLE.
- **Wiring:** Use copper wire only. For supply connection, use wires rated for at least 75°C.
- **Load Type:** The -SW1, -SWS1, and -SLVS1 are designed for use with permanently installed incandescent, fluorescent (non-dimmable), low voltage, neon/cold cathode, HID, general purpose fan, or tungsten halogen lighting.
- **Temperature:** The -SW1, -SWS1, and -SLVS1 are designed to be used where temperatures are between 32° to 104°F (0° to 40°C).
- **Wallboxes:** Devices mount in standard wallboxes. For easy installation, Crestron recommends using 3 ½” deep wallboxes. Several devices can be installed in one wall box (multigang). This requires the removal of side sections (refer to diagram on page 3) and the derating of the switching device. For a smooth appearance, one-piece multigang faceplates (not supplied) can be installed.
- **Other Switch Devices:** Mechanical 3- or 4-way switches will not work with the -SW1, -SWS1, or -SLVS1.
- **Spacing:** If mounting one device above another, leave at least 4 ½” vertical space between them.

Multigang Installations

In multigang installations, several controls are grouped horizontally in one wallbox. For a smooth appearance, one-piece multigang faceplates (not supplied) can be installed.

1. When combining controls in a wallbox, remove inner side sections prior to wiring (refer to the following figure).

Inner Sections of Multiganged Switches
REMOVE INNER SECTIONS

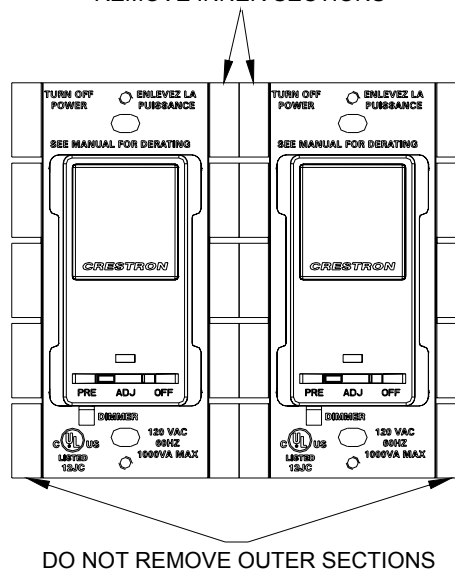

DO NOT REMOVE OUTER SECTIONS

The load capacity must also be derated. The following charts provide derating information for various applications.

Derating Information for Incandescent, Tungsten Halogen, and Electronic Low Voltage Applications

Part Number	No Side Removed	One Side Removed	Two Sides Removed
-SW1	1000W	600W	400W
-SWS1	1000W	600W	400W
-SLVS1	No Derating Necessary		

*Derating Information for Magnetic Low Voltage and Neon/Cold Cathode Applications**

Part Number	No Side Removed	One Side Removed	Two Sides Removed
-SW1	1000VA/750W	600VA/450W	400VA/300W
-SWS1	1000VA/750W	600VA/450W	400VA/300W
-SLVS1	No Derating Necessary		

* VA ratings are for input power to the transformer. If you do not know the input power requirement of the transformer, use the bulb's wattage rating to determine proper rating.

Derating Information for Fluorescent/HID Applications

Part Number	No Side Removed	One Side Removed	Two Sides Removed
-SW1	8A	5A	3A
-SWS1	8A	5A	3A
-SLVS1	No Derating Necessary		

Derating Information for General Purpose Fans

Part Number	No Side Removed	One Side Removed	Two Sides Removed
-SW1	3A	3A	3A
-SWS1	3A	3A	3A
-SLVS1	No Derating Necessary		

- To remove a side section, bend the side section back and forth with a pair of pliers until the section breaks off from the mounting plate. Use a file or sandpaper to remove any excess metal.

Prewire for Master Application

Each device has two Class 2 low voltage wires (plus a ground wire) that provide a Cresnet connection over shielded twisted-pair to a Crestron control system. These wires are routed to the bottom of the device for connection outside of the wallbox. The low voltage wires are pulled from each device location to the Crestron control system or a Crestron connection block device. Use #22 AWG, twisted, shielded, 2-conductor wire. Wiring can be daisy chained, T-tapped, or home run back to the control system. Refer to the following wiring diagram.

Wiring Diagram of CLW device to Cresnet

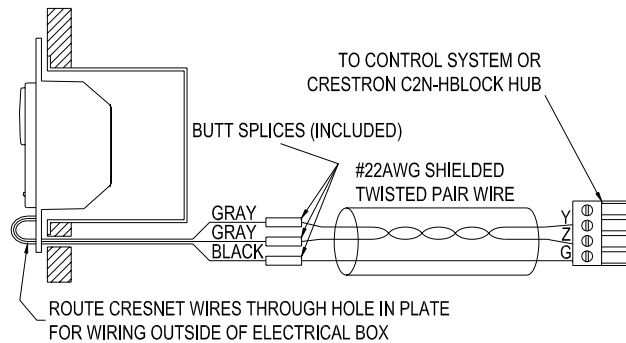

NOTE: The GRAY (Cresnet) wires are not polarized. These wires can be connected to either the Y or Z line on a Cresnet port.

NOTE: The BLACK wire (Cresnet ground) should not be grounded with the GREEN (Ground) wire on the -SW1/-SWS1.

NOTE: Crestron recommends using *Cresnet-DM* cable for connecting the -SW1 and -SWS1 to the Cresnet network.

Installation

NOTE: The -SWS1 must be installed in the same wallbox that contains the connections to the load.

NOTE: The -SW1, -SWS1 require a neutral wire for operation. If no neutral is present, contact a licensed electrician for installation.

WARNING: Turn off power at the circuit breaker. Installing with power on can result in serious personal injury and damage to the device.

NOTE: New installations should be checked for short circuits prior to installing the -SW1, -SWS1, or -SLVS1. With power off, close the circuit and restore power. If the load does not work or a breaker trips, check and correct the wiring or fixture (if necessary). Install the -SW1, -SWS1, or -SLVS1 only when the short is no longer present. **The warranty is void if the -SW1, -SWS1, or -SLVS1 is installed and operated with a shorted load.**

- Turn power off at the circuit breaker.
- If installing multiple switches (-SW1 or -SWS1), note the serial number on each device and make sure they are being installed in the proper location.
- Pull Class 2 low voltage wires through a hole in the drywall located outside of the electrical box, to the Crestron control system or a Crestron connection block device. Leave wires outside of the wallbox for connection to the -SW1 or -SWS1.

NOTE: Alternate wiring methods may be used for the Class 2 wiring connections. Refer to section 725-55, Part D of the 2002 National Electric Code.

- Wire the device for the appropriate application. Choose either “CLW-SW1 / CLW-SWS1 Wiring” shown below, or “CLW-SWS1 with CLW-SLVS1 Wiring”, shown on the following page.

CLW-SW1 / CLW-SWS1 Wiring

NOTE: The -SW1 and -SWS1 require a neutral wire for operation. If no neutral is present, the device will not work. Contact a licensed electrician to install a neutral wire.

The following wiring diagram illustrates installation of the -SW1 or -SWS1.

Wiring Diagram for CLW-SW1 (L) or CLW-SWS1 (R)

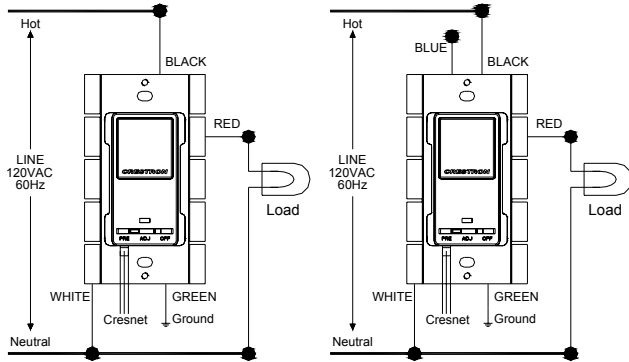

NOTE: The RED (Load) and BLACK (Hot) wires are #14 AWG. The BLUE (Slave) and WHITE (Neutral) wires are #18 AWG. The GREEN (Ground) wire is #16 AWG. The GRAY (Cresnet) wires are #22 AWG. The BLACK wire (Cresnet ground) paired with the GRAY (Cresnet) wires is #22 AWG.

CLW-SWS1 with CLW-SLVS1 Wiring

NOTE: The -SWS1 must be installed in the same wallbox that contains the connections to the load.

The following wiring diagram illustrates installation of the -SWS1 with a -SLVS1.

Wiring Diagram of CLW-SWS1 with CLW-SLVS1

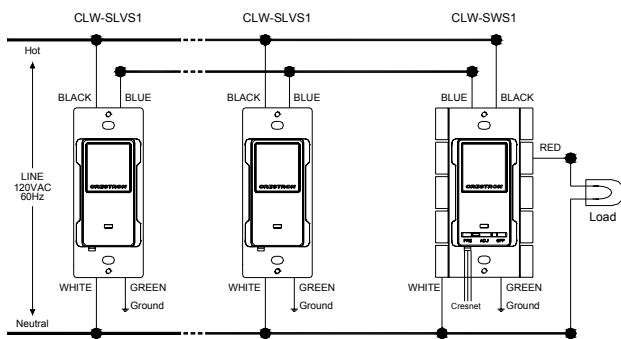

NOTE: Do not connect the BLUE (Slave) wire to the BLACK (Hot) or RED (Load) wires.

NOTE: The RED (Load) and BLACK (Hot) wires are #14 AWG. The BLUE (Slave) and WHITE (Neutral) wires are #18 AWG. The GREEN (Ground) wire is #16 AWG. The GRAY (Cresnet) wires are #22 AWG. The BLACK wire (Cresnet ground) paired with the GRAY (Cresnet) wires is #22 AWG.

NOTE: If a -SWS1 is installed without a -SLVS1, the BLUE lead (Slave) should be capped.

NOTE: The WHITE (Neutral) connection on the -SLVS1 is optional and is only required for operation of the LED. If the neutral is not available, the white lead should be capped off.

5. Splice the gray wires of the -SW1 or -SWS1 to the Class 2 low voltage wires connected to the Crestron control system or a Crestron connection block device. Push the wires and the splices into a hole in the drywall to provide the necessary separation.
6. Push all Class 1 Power wires back into the wallbox and fasten the device to the wallbox with the provided screws.
7. Attach decorative faceplate.
8. Restore power.

Operating Button and Switch

The -SW1, -SWS1, and -SLVS1 feature one pushbutton. The -SW1 and -SWS1 also have a three-position mode selection switch. The function the pushbutton is determined by the position of the mode selection switch. Refer to the following diagram.

Buttons of CLW-SW1, -SWS1, and -SLVS1

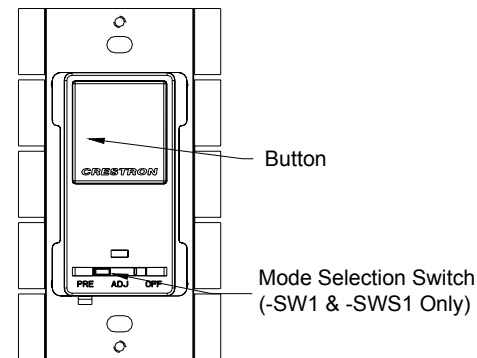

NOTE: The -SLVS1 does not have a mode selection switch. It will act in the same mode as the -SWS1.

OFF

When the mode selection switch is in the “OFF” position, the pushbutton will not have any function and the load is disconnected from the power source. This **must** be used when changing light bulbs to ensure that the load is fully disconnected from power.

ADJ

When the switch is in the ADJ position, pressing and holding the pushbutton will set a delay time for deactivating the load when the switch is in the PRE position. To set the delay time, press and hold the pushbutton for the desired amount of time delay and release. When the pushbutton is released, the LED will flash three times to confirm the time delay setting. When done, return the switch to the PRE position.

NOTE: If a time delay is not set, the delayed-off feature is disabled by default.

PRE

When the switch is in the PRE position, the load can be manually activated and deactivated with the pushbutton. Pressing the pushbutton will deactivate the load after a delay that was set when the switch was in the ADJ mode. During the delay, the LED will flash. Tapping the pushbutton during the delay will deactivate the load without a delay.

NOTE: The device may be warm to the touch during operation. This is normal.

Return and Warranty Policies

Merchandise Returns / Repair Service

1. No merchandise may be returned for credit, exchange, or service without prior authorization from CRESTRON. To obtain warranty service for CRESTRON products, contact the factory and request an RMA (Return Merchandise Authorization) number. Enclose a note specifying the nature of the problem, name and phone number of contact person, RMA number, and return address.
2. Products may be returned for credit, exchange, or service with a CRESTRON Return Merchandise Authorization (RMA) number. Authorized returns must be shipped freight prepaid to CRESTRON, 6 Volvo Drive, Rockleigh, N.J, or its authorized subsidiaries, with RMA number clearly marked on the outside of all cartons. Shipments arriving freight collect or without an RMA number shall be subject to refusal. CRESTRON reserves the right in its sole and absolute discretion to charge a 15% restocking fee, plus shipping costs, on any products returned with an RMA.
3. Return freight charges following repair of items under warranty shall be paid by CRESTRON, shipping by standard ground carrier. In the event repairs are found to be non-warranty, return freight costs shall be paid by the purchaser.

CRESTRON Limited Warranty

CRESTRON ELECTRONICS, Inc. warrants its products to be free from manufacturing defects in materials and workmanship under normal use for a period of three (3) years from the date of purchase from CRESTRON, with the following exceptions: disk drives and any other moving or rotating mechanical parts, pan/tilt heads and power supplies are covered for a period of one (1) year; touchscreen display and overlay components are covered for 90 days; batteries and incandescent lamps are not covered.

This warranty extends to products purchased directly from CRESTRON or an authorized CRESTRON dealer. Purchasers should inquire of the dealer regarding the nature and extent of the dealer's warranty, if any.

CRESTRON shall not be liable to honor the terms of this warranty if the product has been used in any application other than that for which it was intended, or if it has been subjected to misuse, accidental damage, modification, or improper installation procedures. Furthermore, this warranty does not cover any product that has had the serial number altered, defaced, or removed.

This warranty shall be the sole and exclusive remedy to the original purchaser. In no event shall CRESTRON be liable for incidental or consequential damages of any kind (property or economic damages inclusive) arising from the sale or use of this equipment. CRESTRON is not liable for any claim made by a third party or made by the purchaser for a third party.

CRESTRON shall, at its option, repair or replace any product found defective, without charge for parts or labor. Repaired or replaced equipment and parts supplied under this warranty shall be covered only by the unexpired portion of the warranty.

Except as expressly set forth in this warranty, CRESTRON makes no other warranties, expressed or implied, nor authorizes any other party to offer any warranty, including any implied warranties of merchantability or fitness for a particular purpose. Any implied warranties that may be imposed by law are limited to the terms of this limited warranty. This warranty statement supercedes all previous warranties.

Trademark Information

All brand names, product names, and trademarks are the sole property of their respective owners. Windows is a registered trademark of Microsoft Corporation. Windows95/98/Me/XP and WindowsNT/2000 are trademarks of Microsoft Corporation.