

Section	Group	Weight (Kg/Pounds)	Year	Month
8	89		2002	06

Tow bar wiring, 7-pin



M3702107



A0000162



A0000161

Nm
lbf.ft

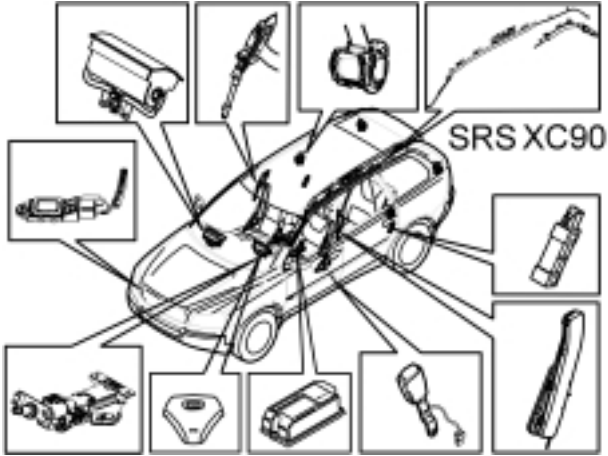

R8802817

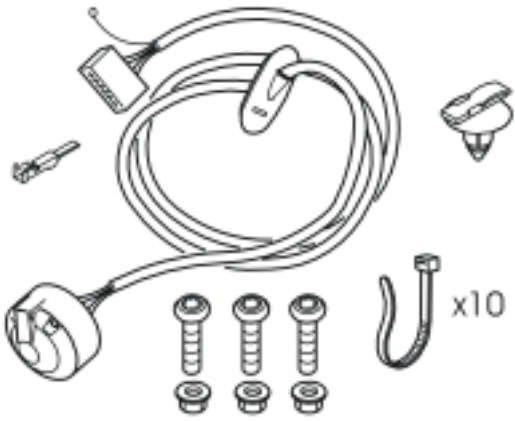

M3702108

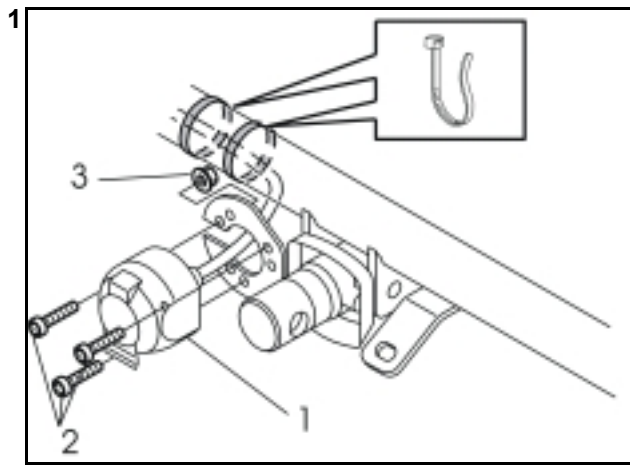

M3702248

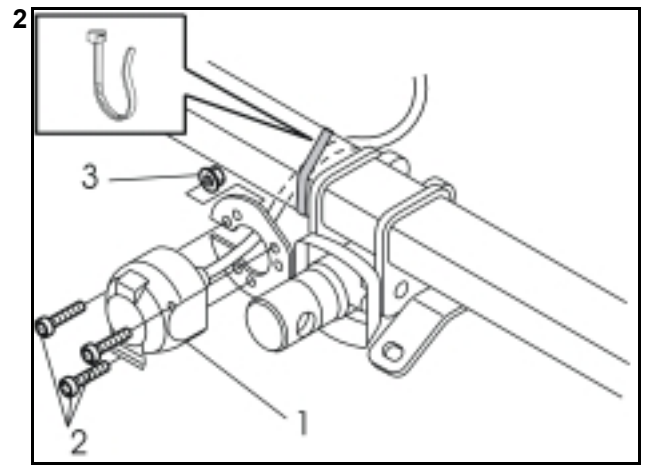

M3702109

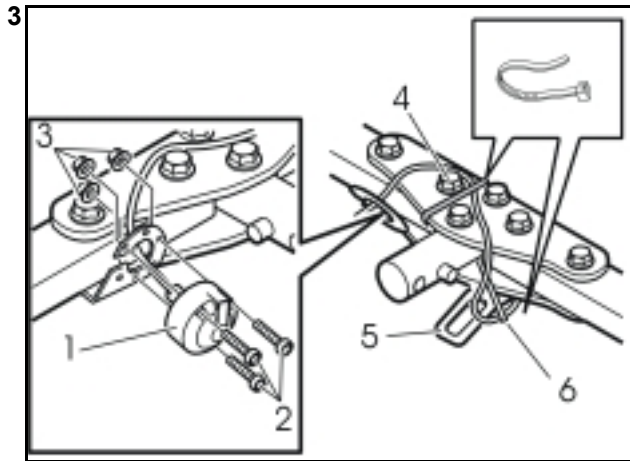

D3701464

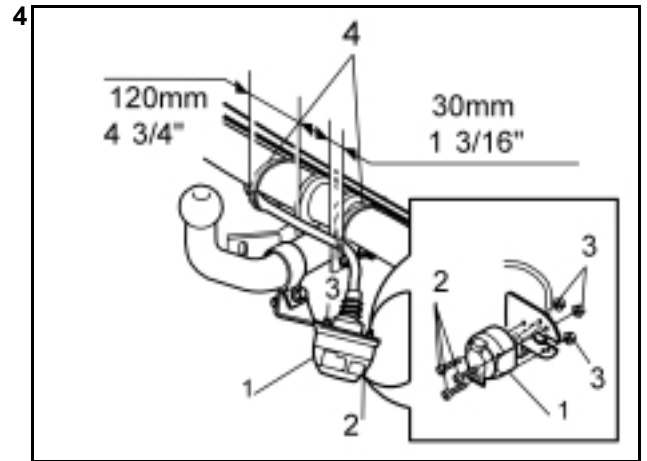

M8902146

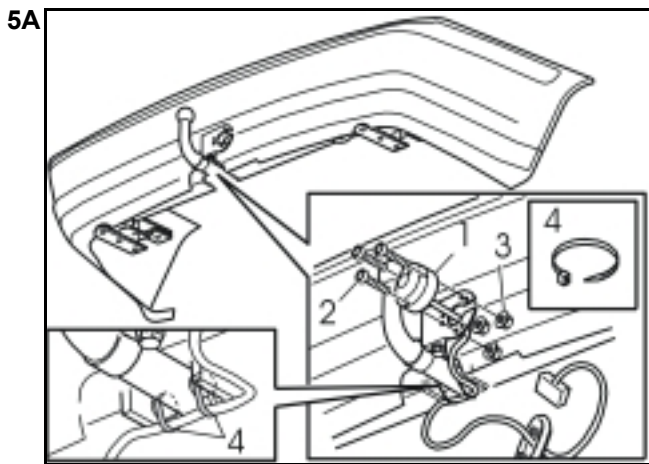

M3702110

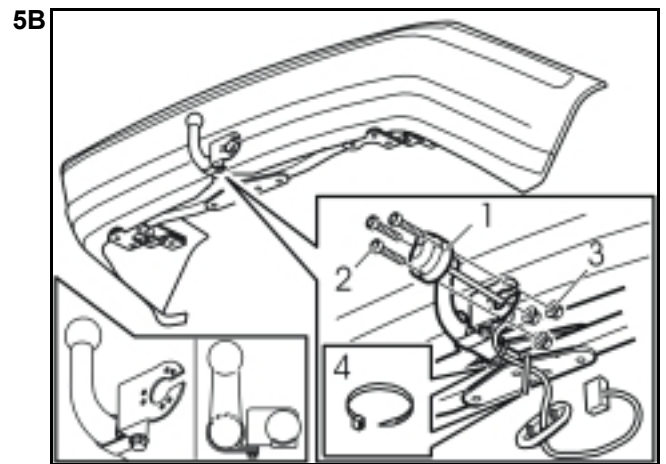

M3702158

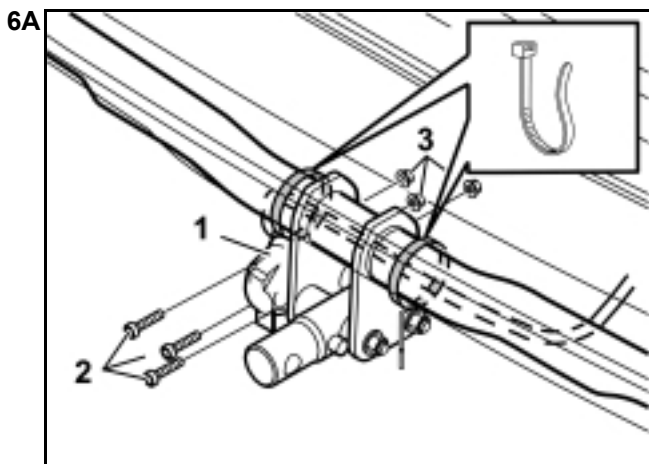

R8903037

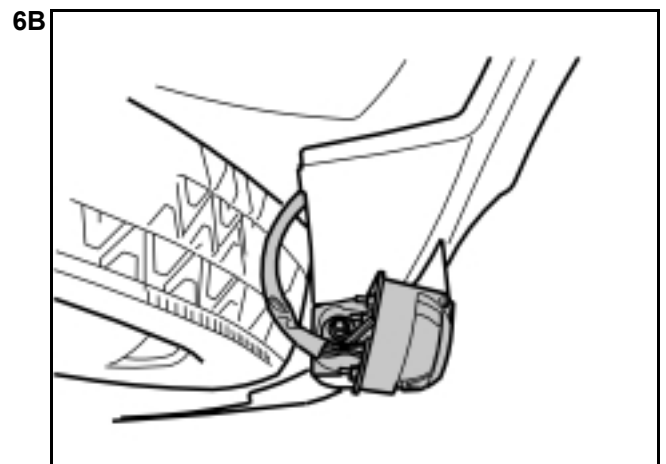

R8903038

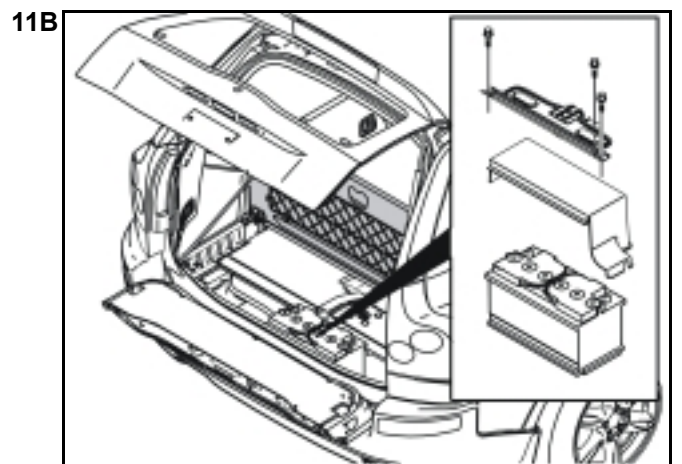
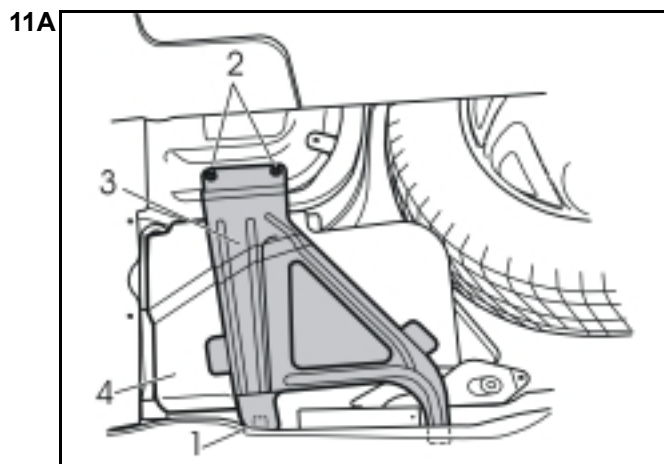
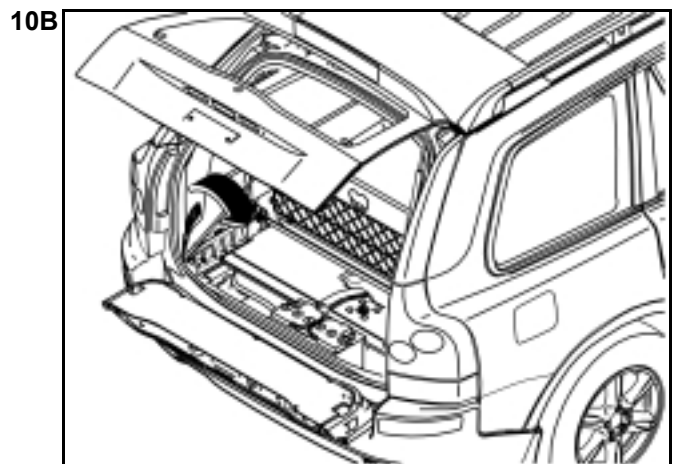
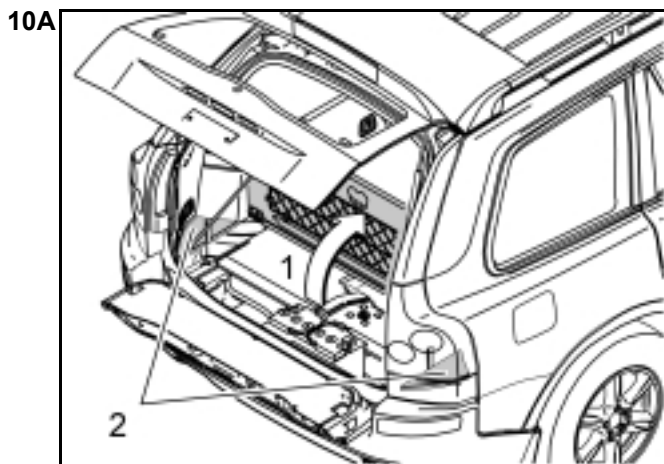
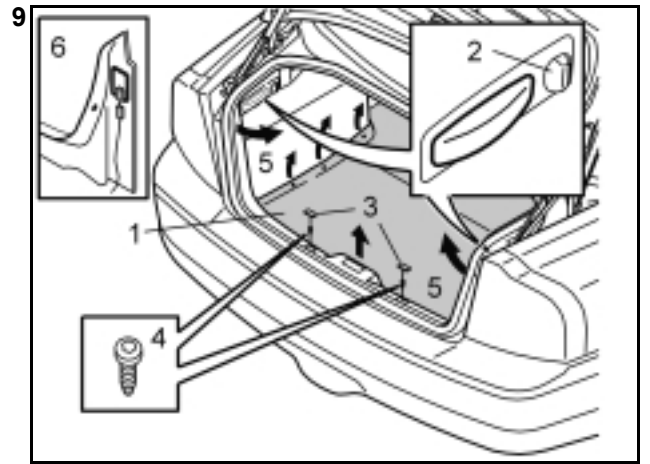
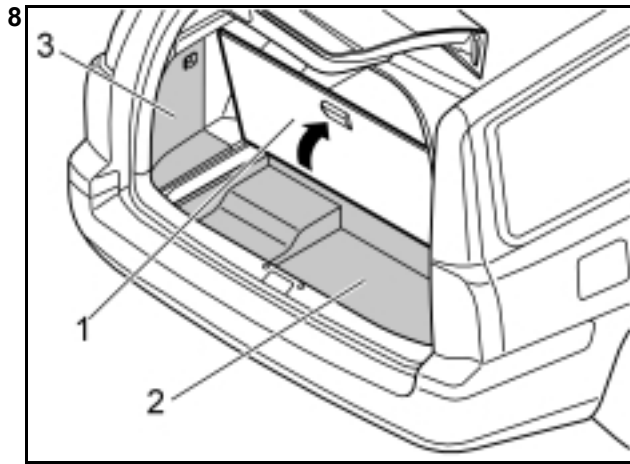
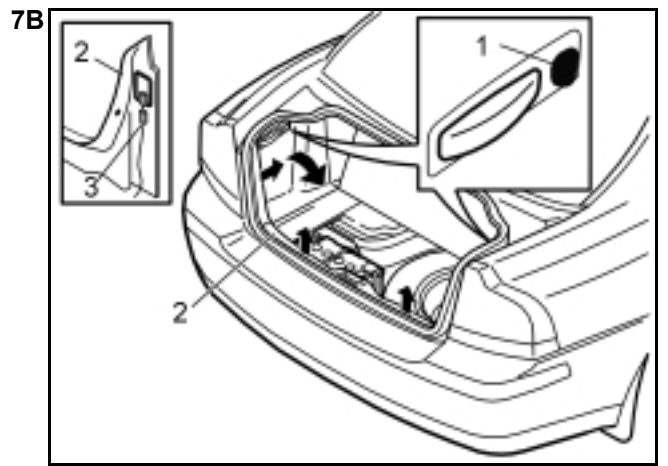
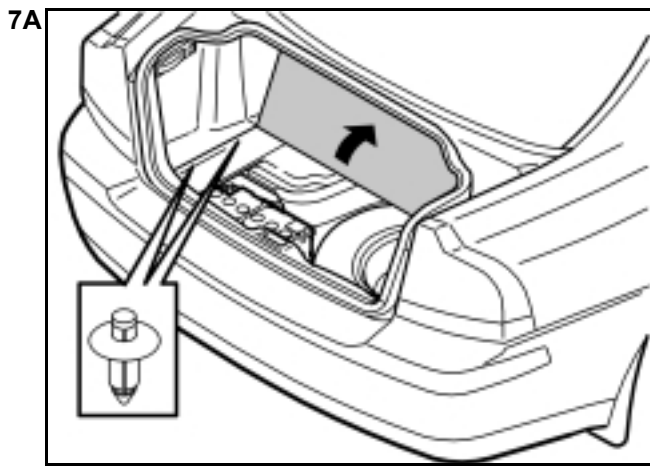

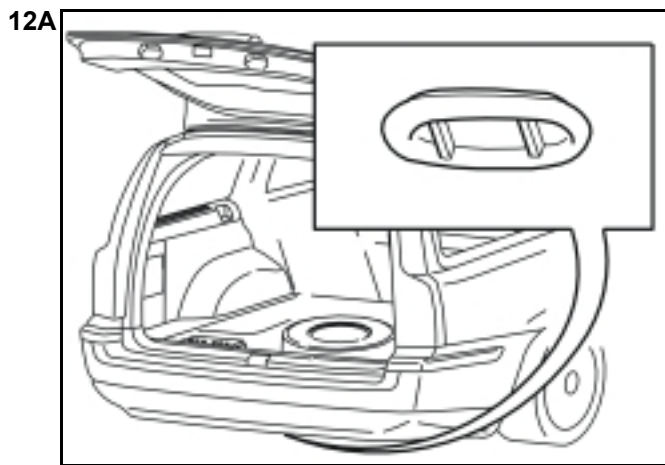

M310077

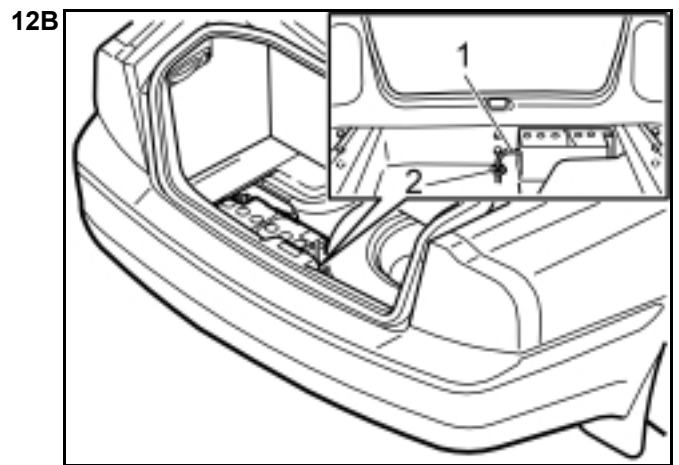

D310058

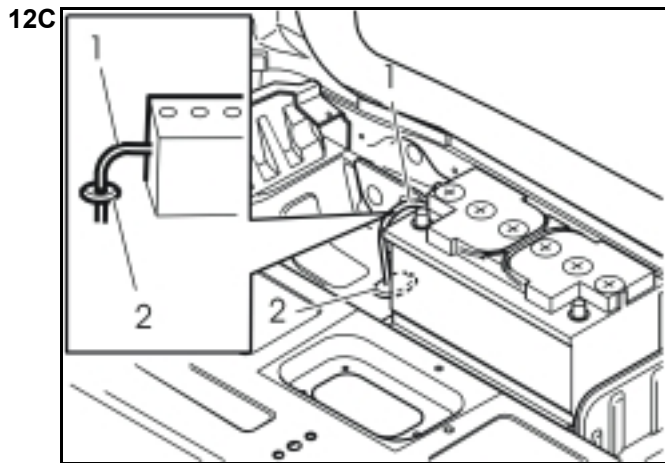

R3100141

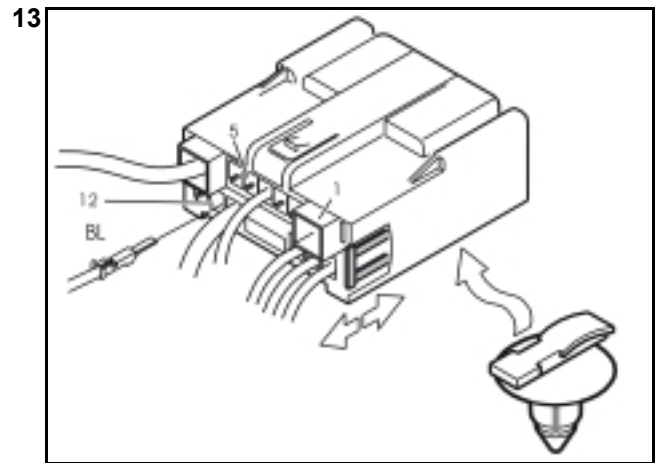

M3702159

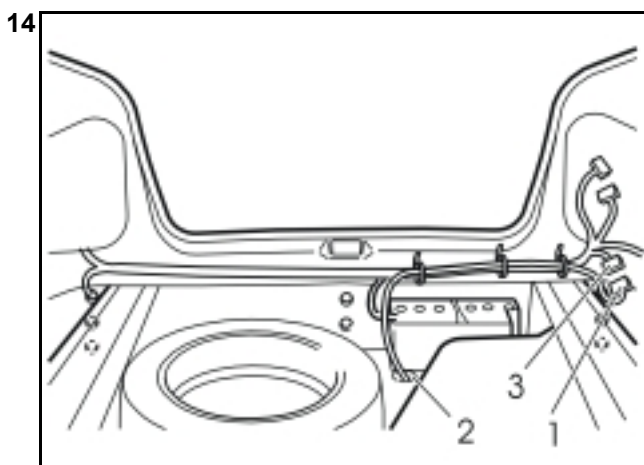

M3100112

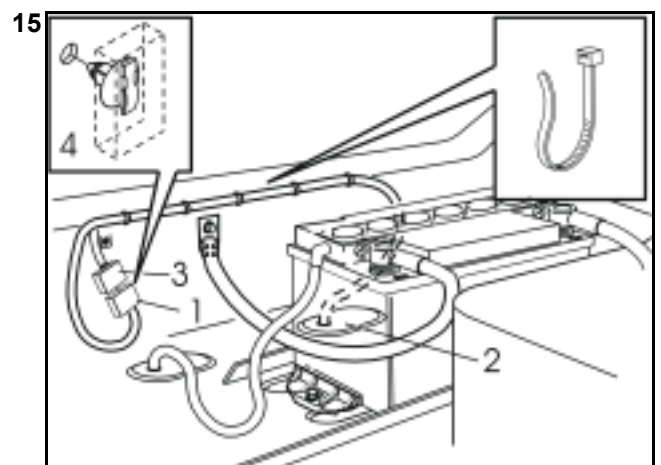

M3100086

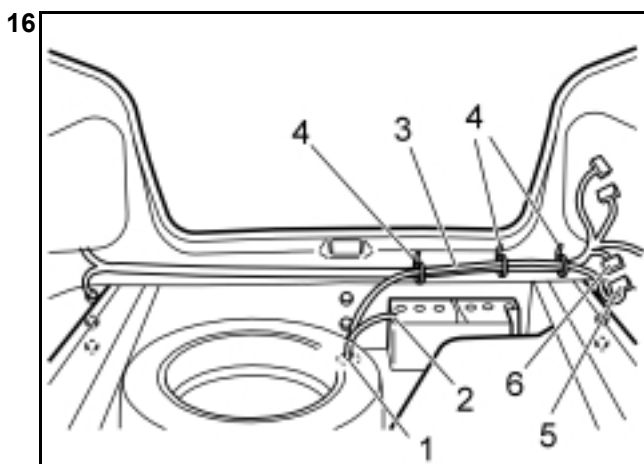

D310059

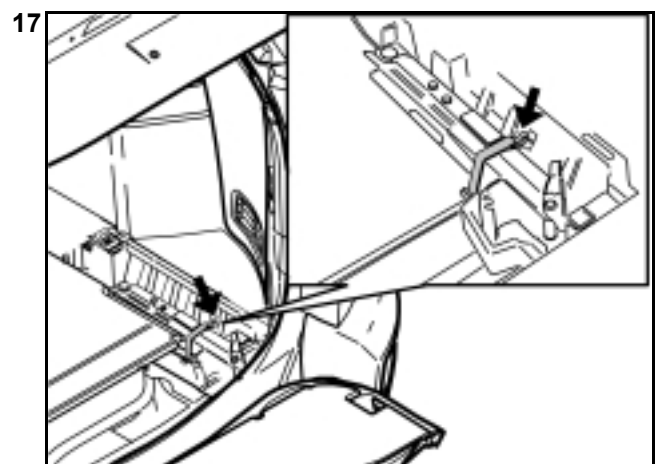

R8902823

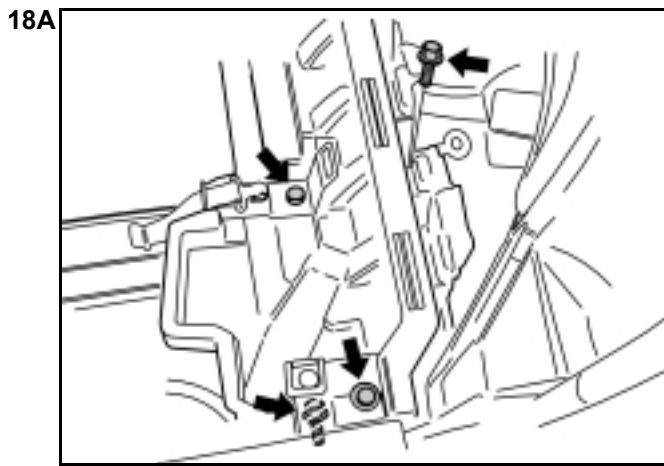

R8903022

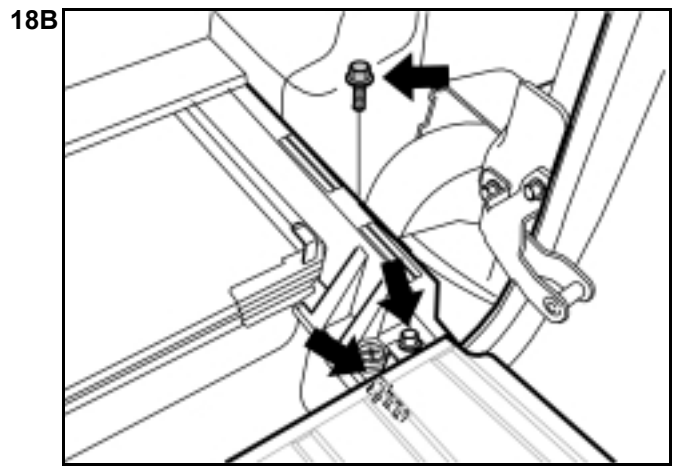

R8903087

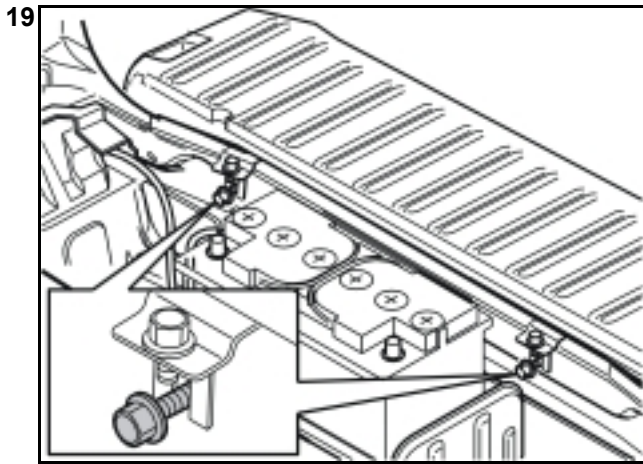

R3100168

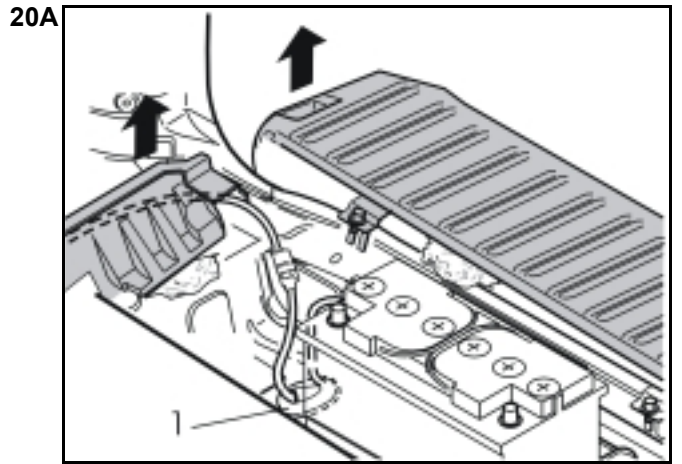

R3100169

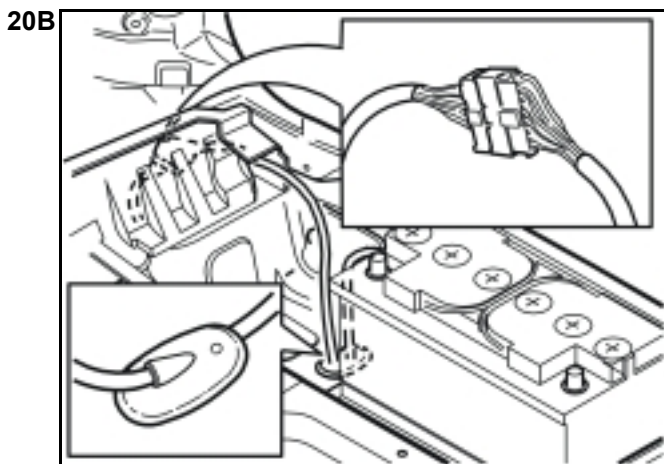

R3903744

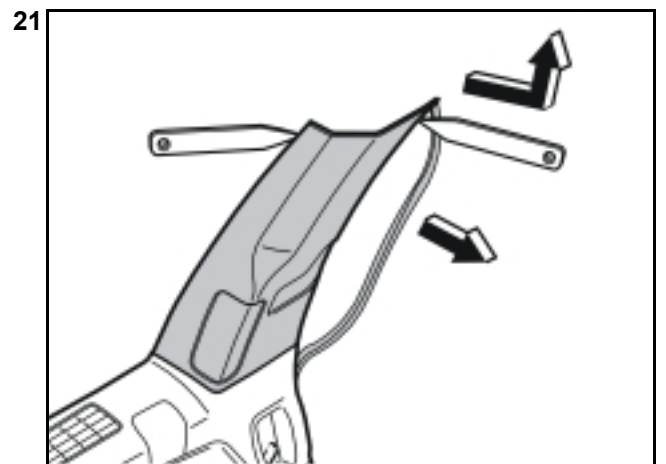

R3903738

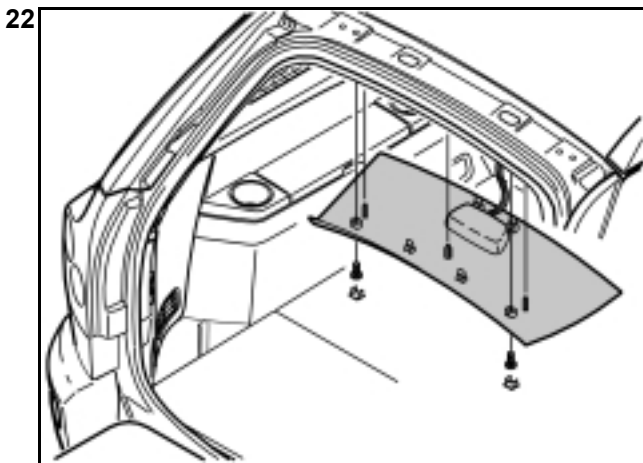

R8504201

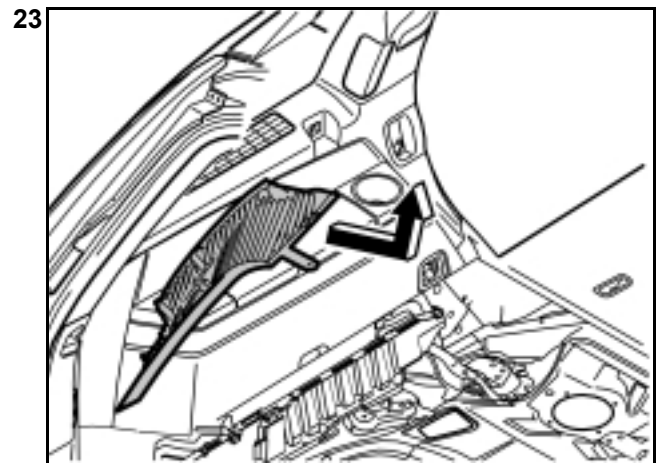

R8504123

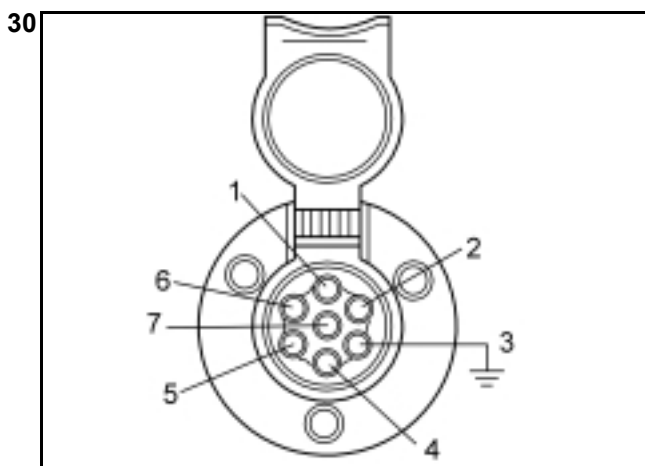
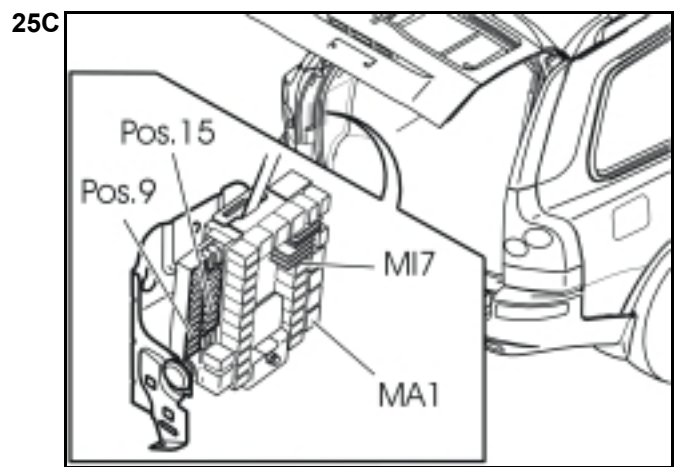
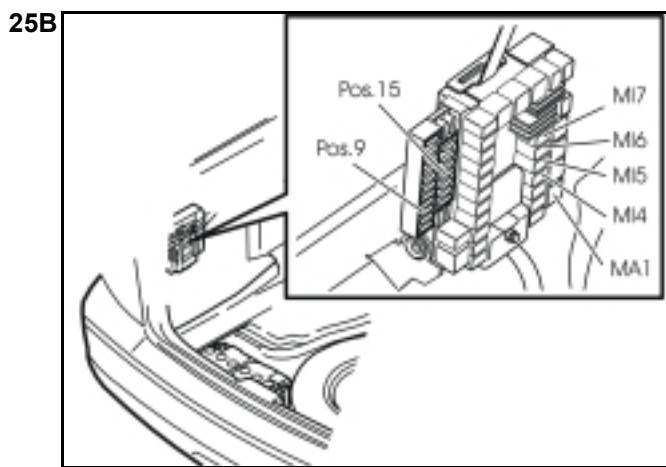
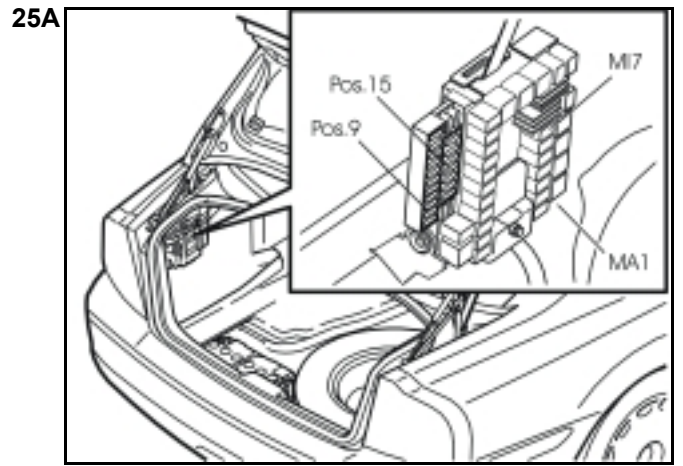
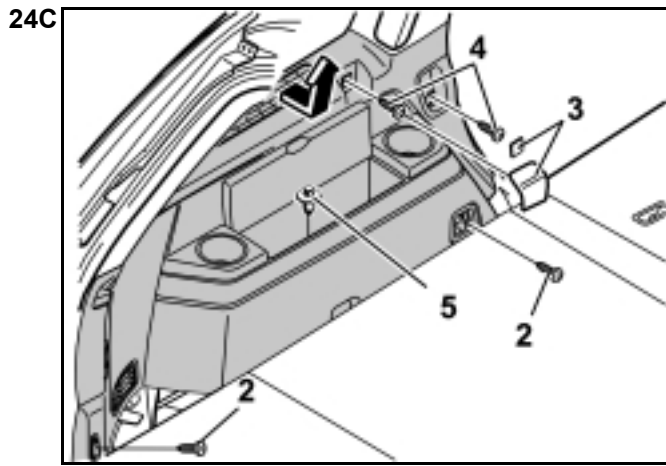
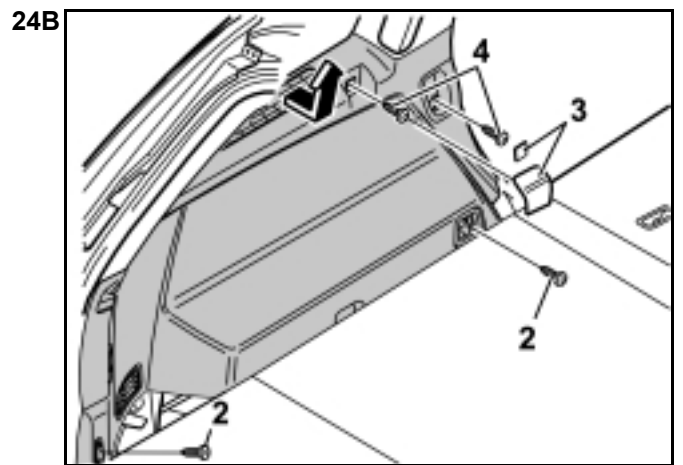
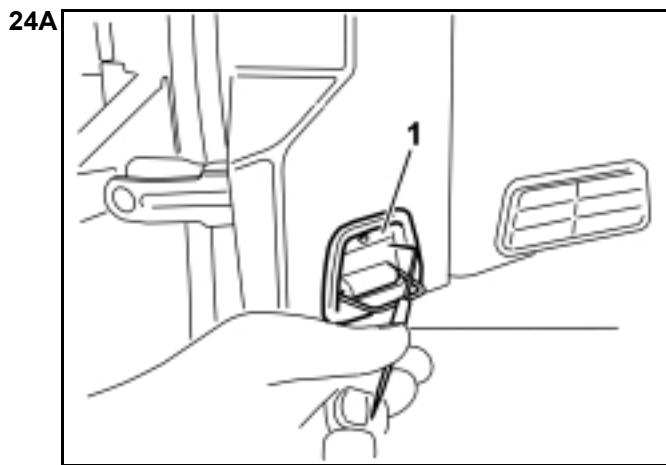

English

INTRODUCTION

- **NOTE! Read through the entire text before carrying out any work.**
- The front page gives the date of this edition and the edition it replaces
- The second page shows the tools needed for the installation and the contents of the installation kit
- The illustrations display the procedure in order of operation. The order of operation is repeated in the text section
- Cut out the text page in order to follow the illustrations and text at the same time.

Cars equipped with SRS/SIPS (Airbag)

WARNING! Extra care must be taken when working on cars equipped with SRS/SIPS air bags. This is important to prevent:

1. Personal injury
2. Damage to or malfunction of the SRS/SIPS system.

Work on the SRS/SIPS systems or related components must always be carried out by an authorised Volvo workshop.

Is the car equipped with SRS (supplemental restraint system)?

Cars equipped with a driver's airbag have the letters "SRS" imprinted on the centre panel of the steering wheel. Cars equipped with driver's and passenger airbags are marked with "SRS" on both the steering wheel centre panel and also on the dashboard close to the airbag.

If the car is equipped with SIPS (side impact protection system) a "SIPS" decal is marked on both the front seats.

Cars equipped with inflatable curtains have the marking "SRS" on one of the panels along the posts on the inside of the car.

Cars equipped with SRS (supplemental restraint system) also have a "SRS" decal on the front windscreen.

Do not damage the SRS wiring!

Do not trap, fray, pierce or damage the SRS wiring. SRS wiring has orange casing and/or is plaited.

Steering and front suspension

The contact reel in the SRS system can easily be damaged when working on the steering wheel, steering shaft or steering gear. Refer to the SRS (supplemental restraint system) Service Manual or service instructions in VIDA for information on carrying out such work. This is to prevent damage.

SRS warning lamp

If the SRS warning lamp lights after repairs have been carried out, take the car to an authorised Volvo workshop.

SRS collision sensor control module

S60 / V70 (00-) / S80 / XC90

The collision sensor control module is located on the transmission tunnel in the centre console, in front of the parking brake.

WARNING!

The air bag inflation areas must not be obstructed. Never place any objects, such as upholstery or accessories, within these areas. The panels must be able to deploy in the correct manner at the right time otherwise there is a risk of personal injury in the event of a collision.

WARNING!

The ignition must be in position "0" and the key removed from the ignition if any connector in the SRS system is to be disassembled. Then wait at least one minute. Then disconnect the battery negative lead before disassembling any of the connectors. When work is completed the ignition key must be turned to position "II" before reconnecting the battery negative lead.

Tow bar wiring, 7-pin

NOTE! The relay and fuses are not included in the kit.

Installing the connector for detachable tow bars

1 Applies to the S60

- Install the trailer connector (1). Use the three screws (2) and the nuts (3). Tighten
- Route the cable along the underneath of the tow hitch member as illustrated
- Secure the cable using two tie straps.

2 Applies to the V70 (00-) and V70XC (01-)

- Install the trailer connector (1). Use the three screws (2) and the nuts (3). Tighten
- Ensure that the cable harness is as close to the centre mounting on the tow bar member as possible. This is important to prevent the cable harness from being caught in the cut-out bumper
- Secure the cable using a tie strap.

3 Applies to the S80

- Install the trailer connector (1). Use the three screws (2) and the nuts (3). Tighten
- Route the cable harness behind the screw (4) on top of the tow bar. Then route the cable harness down past the bracket (5)
- Clamp the cable harness at the bracket. Tighten the clamps (6).

Installing the connector for fixed tow bars

4 Applies to the S60

- Install the trailer connector (1). Use the three screws (2) and the nuts (3). Tighten
- Leave the bracket hanging down as illustrated
- Secure the cable harness at the tow hitch member on each side of the tow hitch. Use a tie strap (4)
- Position the tie straps according to the listed dimensions
- Do not tighten the clamps fully yet.

5 Illustration A applies to the V70 (00-) and V70XC (01-)

Illustration B applies to the S80

- Install the trailer connector (1). Use the three screws (2) and the nuts (3). Tighten
- Clamp the cable harness at the tow bar. Tighten the clamp(s) (4).

Installing the connector XC90

6 On the XC90 the cable harness is routed in the same way regardless of the tow hitch type

- Install the trailer connector (1). Use the three screws (2) and the nuts (3). Tighten
- Route the cable harness to the right along the front edge of the tow hitch member
-

NOTE! If the cable harness is stretched too far it may be worn through by the lower edge of the bumper.

Ensure that the cable harness forms a small loop around the lower edge of the bumper as illustrated in illustration B

- Secure the cable harness using a tie strap on each side of the brackets for the tow hitch member.

Cargo compartment preparations

7 Applies to the S60

Illustration A

- Fold back the carpet
- Remove the clips at the bottom edge of the right and left folding panels (press the centre of the clips until there is an audible click)
- Remove the clips.

Illustration B

- Turn the handle (1) on the right and left-hand sides. Turn the handle through 90°.
- Fold the panels inwards. Lift the panels out
- Pull the tailgate sill trim panel (2) forwards on the right and left hand sides until the two clips on each side release. Carefully pull the panel. Use some force as the panel is tightly secured. Pull the panel straight up until the four clips on the underside release
- Remove the wiring (3) for the cargo compartment lighting
- Lift out the sill trim panel.

8 Applies to the V70 (00-) and V70XC (01-)

- Lift up the floor hatch (1). Lift up the storage hatch (2). Remove these two hatches from the car
- Remove the side panels (3) on both sides.

9 Applies to S60 and S80

- Fold the cargo compartment carpet (1) to one side
- Turn the clips (2). Fold in the side panels on both sides
- Remove the two covers (3). Remove the screws (4) underneath the covers. Grip the outer edges of the panel (5). Pull the panel inwards towards the centre so that the clips release at the sides. Disconnect the connectors (6) for the side lamps. Remove the panel by pulling it straight upwards so that the clips release from the rear crossmember.

10 Applies to the XC90

Illustration A

Applies to cars with two rows of seats

- Fold up the centre rear floor hatch (1)
- If the floor hatch is equipped with a carrier bag holder, it is secured by a strap on each of the shorter sides of the storage box. Release the straps and remove the carrier bag holder
- Remove the storage box
- If the fog tail lamp and/or positive power supply / charge function is being connected, remove the floor hatch completely by folding it almost all the way down and pulling it out backwards from its mountings.

Applies to cars with three rows of seats and integrated carrier bag holder on the underside of the centre floor hatch

- Fold the rear centre floor hatch up
- Detach the two straps from the panel. Lift up the rear edge of the panel. Fold the floor hatch back towards the panel and lift out the floor hatch and the panel.

Applies to cars with three rows of seats without integrated carrier bag holders

- Lift up the centre rear floor hatch at the rear edge and lift it out
- Remove the two side floor hatches (2).

For all CX90

- Remove the two side floor hatches (2).

Illustration B

- Remove the folding side panel on the left and right-hand sides of the cargo compartment.

11 Illustration A

- Remove the screw (1), the nuts (2) and then the bracket (3) (pull the bracket forwards)
- Lift off the protective cover (4).

Illustration B applies to the XC90

- Remove the three screws in the battery holder. Lift out the battery holder
- Remove the cover from the battery.

12 Illustration A applies to the S60, V70 (00-) and V70XC (01-)

- Remove the cover plug from the hole in the bodywork (battery drainage is not affected). See the illustration.

Illustration B applies to the S80

Illustration C applies to the XC90

- Remove the drainage hose (1) from the battery
- Remove the rubber seal (2). The rubber seal will not be used again
- Pull off the small narrow rubber strap on the new rubber seal
- Thread the old drainage hose through the new rubber seal. Ensure that the hose is unimpeded and is not kinked.

Cable routing

- ## 13
- Install the new holder for the connector
 - Unlock the red catches: Press the catches forward
 - Connect the blue (BL) cable to terminals 1, 5 or 12, depending on the desired function. Terminals: 1 = Charging; 5 = Fog tail lamp; 12 = Reversing lamp
 - Return the catches to the locked position.

NOTE! If the "Charging" function is to be used, the existing cable terminal must be cut off and replaced with the cable terminal from the kit.

14 Applies to the S60

- Route the cable harness from the tow bar connector through the hole in the floor
- Adjust the position of the rubber seal (2) so that there is not too much slack in the cable under the car
- Install the rubber seal in the hole
- Route the cable as illustrated. Clamp in the existing cable harness in the sill trim panel. Ensure that the cable harness is not impeded by the battery holder and the protective cover
- Connect the cable harness connector (1) to the existing connector (3).

15 Applies to the V70 (00-) and V70XC (01-)

- Route the cable harness from the tow bar connector through the hole in the floor
- Adjust the position of the rubber seal (2) so that there is not too much slack in the cable under the car
- Install the rubber seal in the hole
- Route the cable as illustrated. Clamp in the existing cable harness in the sill trim panel. Ensure that the cable harness is not impeded by the battery holder and the protective cover
- Connect the cable harness connector (1) to the existing connector (3)
- Secure the two connected connectors (4) in the existing hole in the bodywork.

16 Applies to the S80

- Route the cable harness from the tow bar connector through the hole in the floor
- Adjust the position of the rubber seal (1) so that there is not too much slack in the cable under the car
- Install the rubber seal in the hole
- Connect the drainage hose (2) to the battery
- Route the cable harness (3) along the existing wiring
- Install the clamps (4)
- Connect the cable harness connector (5) to the existing connector (6)
- Clamp any excess cable together with the connector.

17 Applies to cars with two rows of seats

Release the restraining strap for the jack and lift it out.

18 Illustration A applies to cars with two rows of seats

Illustration B applies to cars with three rows of seats

Remove the screws holding the support for the floor in the cargo compartment at the rear edge.

- 19 Slacken off the two screws for the floor extension brackets.

20 Applies to the XC90

Illustration A

- Route the cable harness from the tow bar socket through the hole in the floor. It may be necessary to remove the spare wheel which partially obstructs the hole in the floor
- Adjust the position of the rubber seal (1) so that there is not too much slack in the cable under the car
- Install the rubber seal in the hole
- Pull up the floor extension on the right-hand side. Position a shim underneath it
- Pull up the rear edge of the support for the floor in the cargo compartment. Push the connector into the space behind the right-hand rear wheel well.

NOTE! Do not damage the support for the floor in the cargo compartment. It is brittle.

- Position the cable in the cut-out at the rear edge of the support for the floor in the cargo compartment
- Reinstall the support for the floor in the cargo compartment and the floor extension. Tighten the three screws
- Applies to cars with two rows of seats: reinstall the jack.

Illustration B

- Connect the routed cable harness to the existing pre-routed cable harness in the space
- Route the excess cable into the small space and secure to the existing cable harness. Ensure that the connectors are secured so that they do not rattle
- Reinstall the drain hose for the battery
- If the fog tail lamp and/or positive power supply / charge function is being connected for the XC90, continue with point 21. Otherwise go directly to point 25.

Connecting the fog tail lamp and/or positive power supply / charge function

NOTE! To connect the positive power supply / charge function for the XC90, remove the side panel on the left-hand side of the cargo compartment according to points 21-24.

- 21
- Pull off the rubber strip at the rear edge of the door opening to the left-hand rear door opposite the left C-post panel
 - Carefully pry off the left-hand C-post panel sides at the top using a plastic weatherstrip tool Then pull until the three clips on the inside release. Do not damage the headlining or the panel
 - Remove the panel by pulling upwards slightly and unhooking it from the side panel.

- 22** – Remove the rear headlining covers and the screws underneath the covers
- Carefully pry off the panel at the rear edge using a plastic weatherstrip tool
 - Pull the rear edge of the panel downwards until the four clips on the top have released
 - If the car has lighting in the panel, disconnect the connector
 - Pull the panel backwards to release it.
- 23** – Carefully pull off the D-post panel. Start at the top edge then pull down until the three clips on the inside release. Do not damage the panel
- Disconnect the connector on the D-post panel (if the car has a loudspeaker in the D-post there is a connector in the loudspeaker)
 - Remove the panel by pulling upwards slightly and unhooking it from the side panel.

24 **Illustration A shows the removal of the cover for the load securing eyelets**

- Fold out the load securing eyelet
- Insert a scribe with an angled tip into the hole in the top of the cover
- Turn the scribe so that the angled tip engages in the reverse of the cover (1). Pull off the cover.

Illustration B applies to cars with two rows of seats

Illustration C applies to cars with three rows of seats

- Fold up the seats in the third row (applies to cars with three rows of seats)
- Remove the screws (2) for the load securing eyelets in the left-hand side panel
- Remove the covers (3) over the front mountings for the left-hand side panel. Pry them off using a plastic weatherstrip tool or a small screwdriver
- Remove the screws (4)
- Remove the clip (5) at the bottom of the storage compartment in the panel (applies to cars with three rows of seats)
- Remove the panel by pulling it slightly at the top edge so that the clips on the inside release. Remove the panel by pulling it straight upwards.

25 **Illustration A applies to the S60 and the S80**

Illustration B applies to the V70 (00-) and V70XC (01-)

Illustration C applies to the XC90

Install the correct fuse / relay depending on the model (year) and desired function

Applies when connecting the fog tail lamp function

- Install the relay in the rear electronic module, terminal MI 7.

Applies when connecting the automatic shut-off function for the fog tail lamp

–

NOTE! This function requires software unique to the car.

Program the software according to the service information in VIDA.

Applies when connecting the positive power supply / charging function (15 I supply) on the S80 (model year 1999)

- Install the relay in the rear electronic module, terminal MA 1.

NOTE! The relay is already installed in MA1 on cars with all wheel drive and cars with reverse warning as an accessory.

- Install a 15 A fuse in the rear electronic module, terminal 9.

Applies when connecting the positive power supply / charging function (15 I supply) on the S80, S60, V70 (00-) and XC90

- Install the relay in the rear electronic module, terminal MA 1.

NOTE! The relay is already installed in MA1 on cars with all wheel drive and cars with reverse warning as an accessory.

- Install a 20A fuse in the rear electronic module (REM), terminal 15, and a 15A fuse in terminal 9.

Applies to the S80/S60 manufactured before week 38-2001 without positive power supply

- Remove the two relays in terminals MI 6 and MI 4. Replace them with new relays with P/N 8651661. The third relay must not be used for these cars.

Applies to the V70 (00-) manufactured before week 48-2001 without positive power supply

- Remove the three relays in terminals MI 6, MI 5 and MI 4. Replace them with relay P/N 8651661 in terminal MI 6 and MI 4 and relay P/N 8663490 in terminal MI 5.

Finishing work

26 Applies to the XC90

Reinstall:

- the left-hand side panel using the screws and cover.
Tighten the screws in the load securing eyelets.
Tighten to **24 Nm (18 lbf.ft.)**
- the covers for the load securing eyelets
- The D-post panel with the connector
- the rear roof lighting connector (if applicable)
- the rear headlining
- C-post panel.

- 27 – Reinstall the protective cover and the bracket for the battery. (see point 11).

28 Applies to S60 and S80

- Reconnect the connectors for the side lamps.

- 29 – Reinstall the panels (see points 7-10)
- Re-position the cargo compartment carpet.
Alternatively, reinstall the storage compartment and the floor hatches.

30 Checking the 7-pin connector:

1	Left indicators
2	Fog tail lamp / reversing lamp / charging
3	Ground
4	Right indicators
5	Right parking lamps
6	Brake lamp
7	Left parking lamps