

Modular Refrigerant Leak Detection Sensor (MRLDS) Installation and Operation Manual





3240 Town Point Drive NW Suite 100
Kennesaw, GA 30144, USA

Phone 770-425-2724
Fax 770-425-9319

ALL RIGHTS RESERVED

The information contained in this manual has been carefully checked and is believed to be accurate. However, Computer Process Controls, Inc. assumes no responsibility for any inaccuracies that may be contained herein. In no event will Computer Process Controls, Inc. be liable for any direct, indirect, special, incidental, or consequential damages resulting from any defect or omission in this manual, even if advised of the possibility of such damages. In the interest of continued product development, Computer Process Controls, Inc. reserves the right to make improvements to this manual, and the products described herein, at any time without notice or obligation.

FCC COMPLIANCE NOTICE

This device complies with Part 15 of the FCC Rules. Operation is subject to the following two conditions: (1) this device may not cause harmful interference, and (2) this device must accept any interference received, including interference that may cause undesired operation.

Table Of Contents

1 OVERVIEW	1
1.1 SPECIFICATIONS.....	1
1.2 MRLDS MODELS.....	1
1.3 POWERING THE MRLDS.....	1
2 CHOOSING A MOUNTING LOCATION	2
2.1 MOUNTING THE SENSOR.....	2
2.2 MRLDS DIMENSIONS.....	3
3 MRLDS ANALOG VERSION (809-100X)	3
3.1 NETWORK LAYOUT.....	3
3.2 MRLDS WIRING.....	3
3.3 REFRIGERANT JUMPER SETTINGS.....	4
3.4 CONTROLLER SETUP FOR ANALOG MRLDS.....	4
4 MRLDS MODBUS VERSION (809-101X)	5
4.1 NETWORK LAYOUT.....	5
4.2 MRLDS SETUP.....	5
4.3 MRLDS GATEWAY.....	7
4.4 CONTROLLER SETUP FOR MODBUS MRLDS.....	11
5 DIAGNOSTICS	14
5.1 MRLDS LED INDICATORS.....	14
5.2 E2 ALARMING.....	14
5.3 LINEARITY SETTINGS FOR SUPPORTED REFRIGERANTS.....	15

1 Overview

Retail Solutions specs a modular refrigerant leak detection sensor (MRLDS) that continuously monitors for low levels of refrigerants most commonly used in commercial refrigeration systems.

The MRLDS communicates with the E2 controller via a Gateway board connected to the RS485 I/O Network, or via the analog input on a MultiFlex board.

1.1 Specifications

Power Requirements	24 VAC, ±20%, 50/60 Hz, Class 2
Wiring	14 AWG max, Class 2 copper wiring
Power Consumption	Less than 2.7 watts
Output Options	1-5V, 10 K Ohm load RS485 Modbus RTU
Operating Temp.	32 to 149°F (-22 to 149°F with de-icer*) 0 to 65°C (-30 to 65°C with de-icer*)
Humidity	0 to 99% non-condensing
Size	4.5" x 3.5" x 1.6"
Weight	.35 lbs. (160 g)
Pollution Degree	2
Installation Category	II
Range	0 to 1000 PPM
Minimum Detection	25 PPM
Pressure	Operating 10.2 to 15.7 PSIA
Repeatability	±10 PPM at 50 PPM
Linearity	See <i>Table 5-2, "Linearity Settings for Supported Refrigerants," on page 15</i>
Warm-up Time	30 minutes

Table 1-1 - MRLDS Unit Specifications

*De-icer: for environments below 32°F to keep ice from forming on the surface of enclosure.

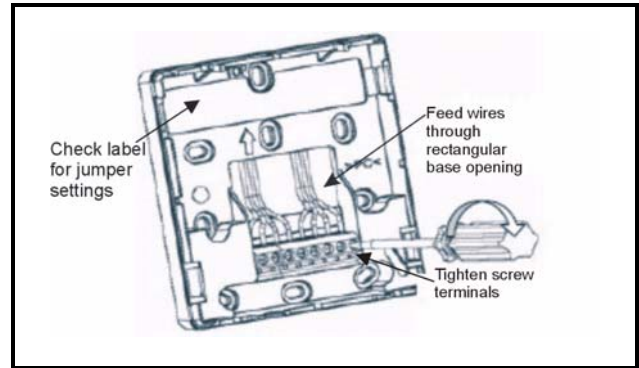

Figure 1-1 - Sensor Base Opening With Screw Terminals

1.2 MRLDS Models

Part Number	Description
809-1000	Voltage Out w/o de-icer*
809-1001	Voltage Out with de-icer*
809-1010	Modbus w/o de-icer*
809-1011	Modbus with de-icer*

Table 1-2 - Available MRLDS Models

1.3 Powering The MRLDS

Part Number	Transformer Description	Number of MRLDS Units Powered
640-0039	24VAC, 10VA Class 2	Up to 3

Table 1-3 - MRLDS Transformer Specifications

The MRLDS unit requires a separate UL Listed/CSA Certified 24VAC Class 2 transformer power supply. One 24VAC, 10VA Class 2 transformer is sufficient for up to three (3) MRLDS units.

Retail Solutions supplies several sizes of transformers for powering multiple MRLDS units (three or more). Note that polarity must be maintained when connecting more than one MRLDS to a single transformer.



WARNING: The MRLDS unit must be always be powered by either a suitable UL 60950/CSA Certified power supply that is isolated from line voltage by double insulation, or an appropriately rated UL Listed/CSA Class 2 transformer. Failure to follow the above can result in serious personal injury or death.

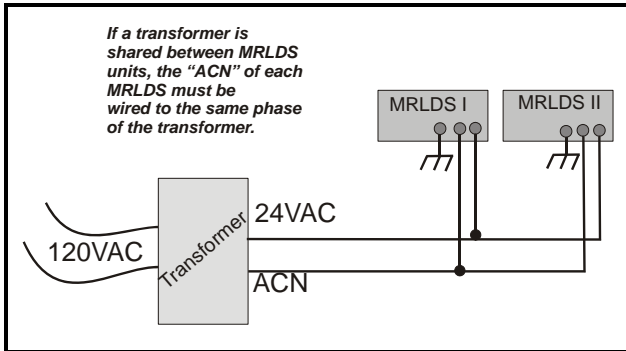

Figure 1-2 - Powering Multiple MRLDS Units

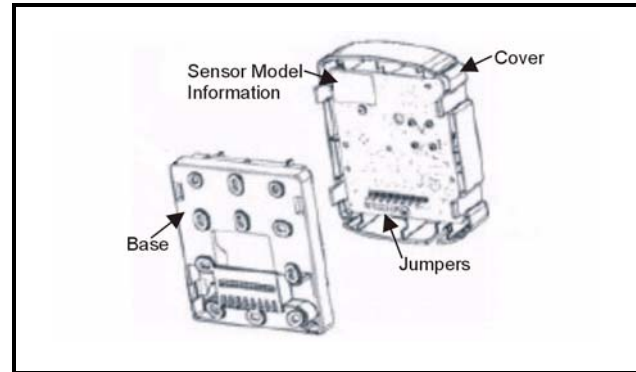

Figure 2-1 - Sensor Base And Cover

2 Choosing a Mounting Location

Proper location of the refrigerant sensor is necessary to ensure accurate measurement of representative air samples.

Mount the sensor:

- Indoors, inside a room area where air circulates freely.
- On a flat, interior surface.
- Approximately 12-18 inches (30-45 cm) from the floor.

Do not mount the sensor:

- On surfaces in unheated areas (less than 0°C), unless using a model with a de-icer.*
- Near heat sources, such as appliances, direct sunlight, or concealed pipes or chimneys.
- On walls subject to excessive vibration.
- In the direct path of an exhaust fan. Excessive air movement will disperse gas before it can be detected. If mounting in the path of excessive airflow cannot be avoided, it will be necessary to turn OFF air circulation for 1/4 to 1/2 hour, 4-6 times a day.



NOTE: For example, if mounted inside a motor room, exhaust fans must be shut off during the intervals that air samples will be tested for refrigerant levels.

2.1 Mounting The Sensor

The refrigeration monitor comprises two basic parts: the base and the cover. The cover incorporates the circuit board with the sensing elements.

1. Fasten the base to a junction box or other support. The base has a number of openings to allow for mounting to various junction boxes.
2. Feed the power and signal wires through the rectangular opening in the base (*Figure 1-1*).
3. Connect the wires to the terminal connector located in the base, as indicated in *Figure 4-2* and *Figure 3-2*.
4. The Modbus MRLDS must be connected to earth ground. Connect earth ground to the MRLDS ground terminal labeled . Connect to earth ground with 14 AWG wire that is less than 6 inches.
5. Align the two side tabs of the cover with the base and snap the cover onto the base.
6. Verify the cover is securely attached to the base by pulling on the top and bottom of the cover as shown in *Figure 2-2*.



NOTE: To remove the cover, grasp it along the recesses and pull it away from the base (*Figure 2-2*). Alternatively, place a screwdriver into the slots indicated in *Figure 2-2* and twist.

3 MRLDS Analog Version (809-100x)

3.1 Network Layout

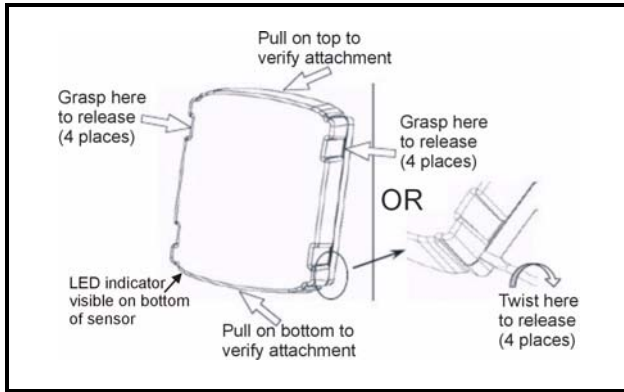

Figure 2-2 - Attaching and Removing Cover

2.2 MRLDS Dimensions

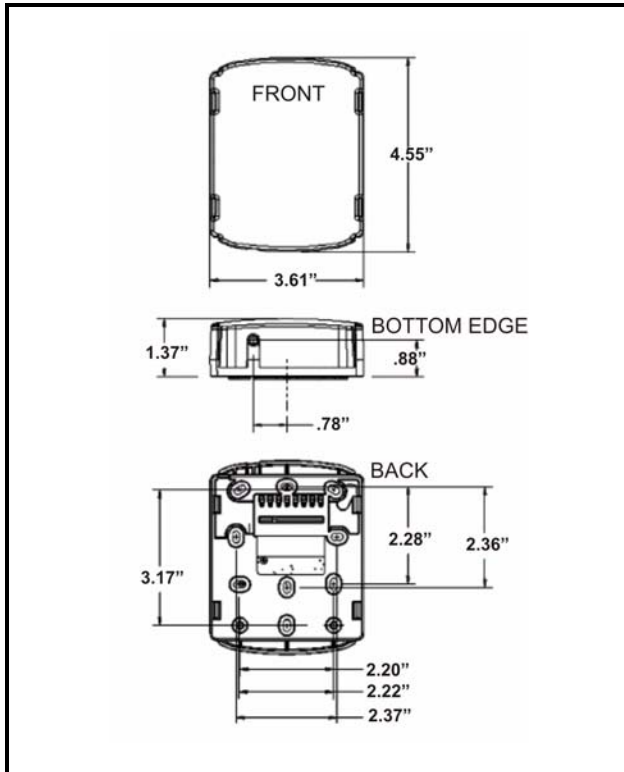

Figure 2-3 - MRLDS Mounting Dimensions

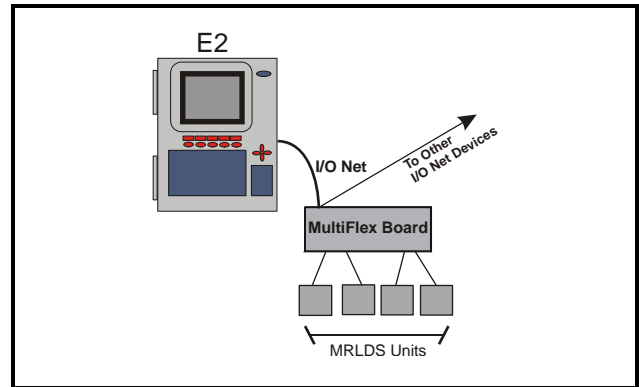

Figure 3-1 - Analog MRLDS Network Layout Example

3.2 MRLDS Wiring

For analog MRLDS units, connect to a MultiFlex board via the analog input (use Belden 8761 cable).

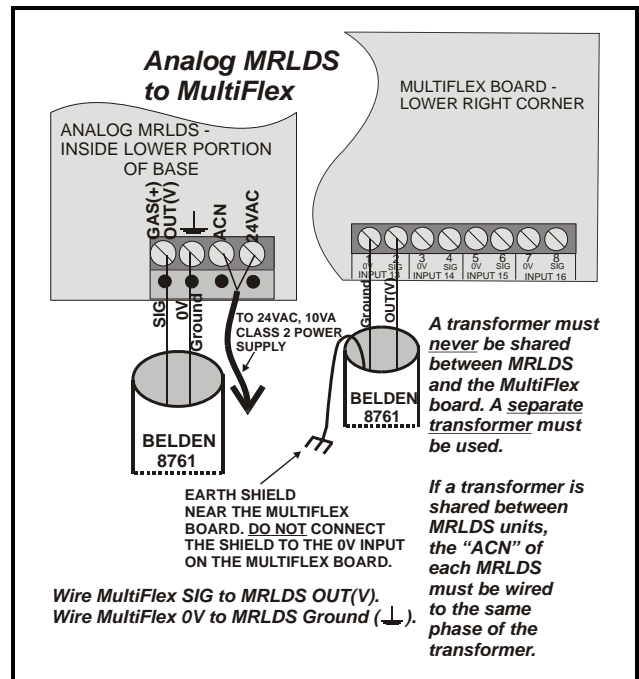

Figure 3-2 - Analog MRLDS Wiring

3.3 Refrigerant Jumper Settings

The jumper settings for refrigerant types are located on the label inside the MRLDS sensor cover (shown in *Figure 1-1*). Set the jumpers according to how they are indicated on the label.

The MRLDS supports ten different refrigerant types. Select the desired refrigerant type by setting one jumper to the **J2** or **J1** sockets (*Figure 2-1*) respective per the inside label.

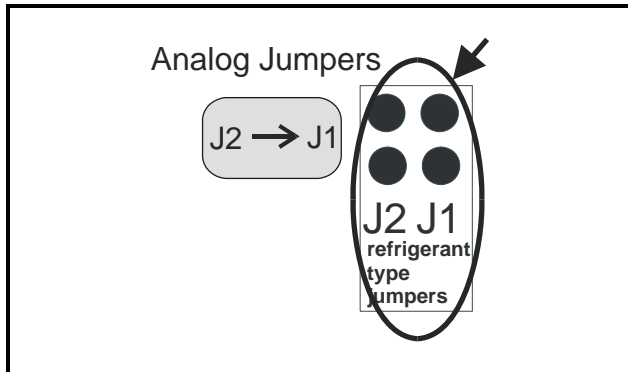

Figure 3-3 - Analog Jumper Layout (Inside Lower Portion of Cover) Enlarged To Show Detail

Refrigerant Type	J2 J1
R-22	⋮
R-134a, R-407A, R-407C, R-410A, R-427A	⋮
R-404A, R-422A, R-422D, R-507	⋮

Table 3-1 - Refrigerant Jumper Settings

3.4 Controller Setup For Analog MRLDS

3.4.1 E2 Controllers Version 2.5 and Newer

1. Log in to the E2 controller.
2. Press the **Menu** button to open the Main Menu.
3. Select **7. System Configuration**.
4. Select **1. Input Definitions**.

5. Select the board/point input.
6. Press **F1 Setup**.
7. Select Analog Sensor.
8. On the Analog Input screen, select **MRLDS Refr.** as the **Sensor Type**. The parameters are then automatically configured for you.
9. Press the  (Back) button to save changes.

If the device is configured and powered correctly, a value will be visible under the **Value** column on the Input Status screen.

3.4.2 Einstein/E2 Controllers Prior to Version 2.5

For Einstein and E2 controllers prior to version 2.5, follow the steps below, set the sensor type to Linear, and manually enter the parameters:

1. Log into the E2 controller.
2. Press the **Menu** button to open the Main Menu.
3. Select **7. System Configuration**.
4. Select **1. Input Definitions**.
5. Select the board/point input.
6. Press **F1 Setup**.
7. Manually enter the following parameters on the Input Setup screen:
 - Sensor Type: **Linear**
 - Low End Point: **0.8V**
 - Low Eng. Units: **-50**
 - Select Eng. Units: **PPM**
 - HighEnd Point: **5.5V**
 - High Eng. Units: **1125**
 - Low End Limit: **-100**
 - HighEnd Limit: **1150**

(Set the alarm failure to < -10PPM.)

8. Press the  (Back) button to save changes.

If the device is configured and powered correctly, a value will be visible under the **Value** column on the Input Status screen.

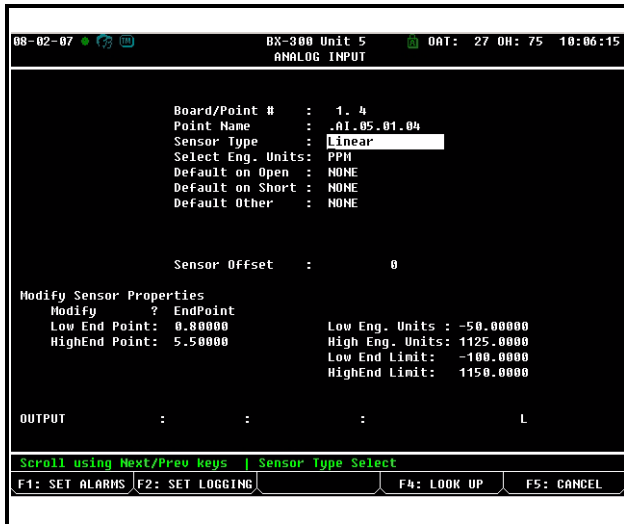

Figure 3-4 - Analog Input Screen Settings Example for E2

3.4.3 RMCC Controllers

For RMCC-type controllers, set the Gain parameter to 250 and Offset to -1000.

4 MRLDS Modbus Version (809-101x)

4.1 Network Layout

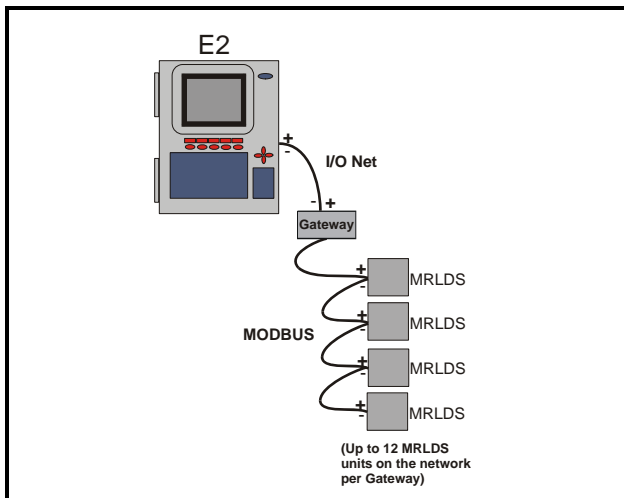

Figure 4-1 - Network Layout Example

4.2 MRLDS Setup

4.2.1 MRLDS Wiring

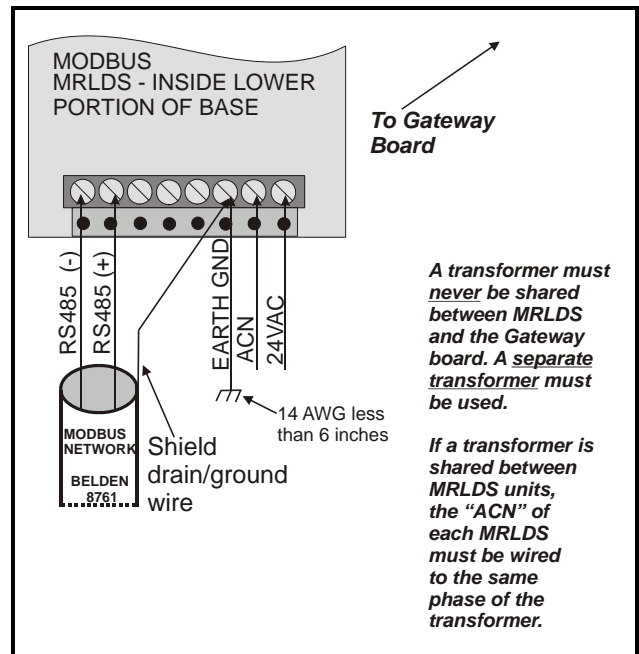

Figure 4-2 - Modbus MRLDS Wiring

4.2.2 MRLDS Network Addressing

Modbus network settings are set on jumpers J5, J4, and J3. Refer to *Table 4-1* (also included on the inside label of the MRLDS) for network addressing with corresponding jumper settings.

If more than one MRLDS is on the network, each unit must have a unique address and be numbered according to the inside label (*Table 4-1*) specifications.

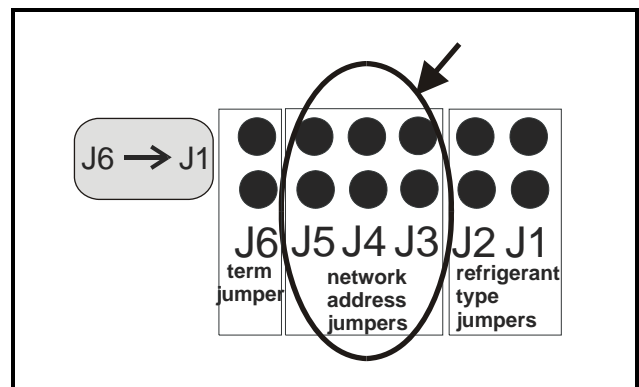

Figure 4-3 - MRLDS Jumpers (Inside Lower Portion of Cover)

4.2.3 Address Settings

Modbus Address Jumper Settings	J5 J4 J3
100	No jumpers installed
101	
102	
103	
104	
105	
106	
107	
108	
109	
110	
111	

Table 4-1 - MRLDS Modbus Address Jumper Settings

4.2.4 Refrigerant Jumper Settings

The jumper settings for refrigerant types are located on the label inside the MRLDS sensor cover (shown in *Figure 1-1*). Set the jumpers according to how they are indicated on the label.

The MRLDS supports ten different refrigerant types. Select the desired refrigerant type by setting one jumper to

the **J2** or **J1** sockets respective per the inside label.

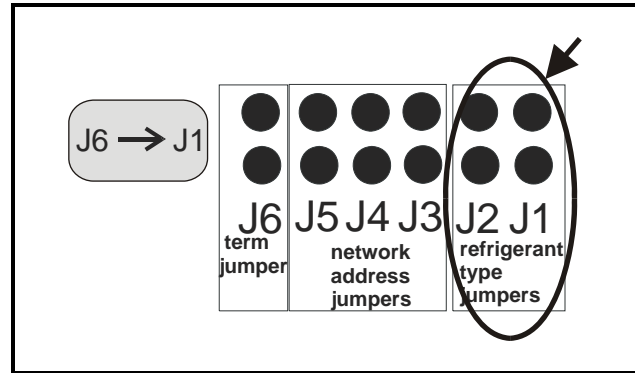

Figure 4-4 - Modbus Jumper Layout (Inside Lower Portion of Cover) Enlarged To Show Detail

Refrigerant Type	J2 J1
R-22	
R-134a, R-407A, R-407C, R-410A, R-427A	
R-404A, R-422A, R-422D, R-507	

Table 4-2 - Refrigerant Jumper Settings



NOTE: When using the MRLDS Gateway, it will only show the base refrigerant type selections (R-22, R-134a, R-404A).

4.2.5 MRLDS Termination

The MRLDS has a built-in, on-board means of termination, so an external termination block is not necessary for terminating. When the device is located at the end of a daisy chain, set jumper JP6 for termination.

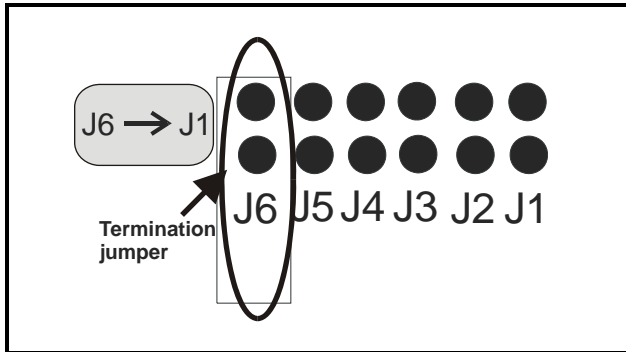

Figure 4-5 - MRLDS Termination (Inside Lower Left of Cover)

4.2.6 Modbus Output

See Table 4-3 below for Modbus registers in the MRLDS Unit. Baud rate: 19,200; each byte is 8 (eight) bits with no parity and 2 (two) stop bits.

Register Name	PDU Address	Logical Address	Range
Fault and Module State	0x0000	1	Under Range 2 (msb)
			Under Voltage 8 (msb)
			Temperature 10 (msb)
			Lamp Fail 40 (msb)
			Test Mode 80 (msb)
			Warm Up Complete 0 (Lsb)
			Cal/Setup 2 (Lsb)

Table 4-3 - RS485 Output Specifications

			Factory Mode 4 (Lsb)
			Trouble Mode 8 (Lsb)
Gas Number	0x0001	2	0 to 40
Gas Concentration	0x0002	3	-20 to 1050 (PPM)
Gas Numbers	R-22 = 6		
	R-404A = 27		
	R-134a = 15		

Table 4-3 - RS485 Output Specifications

4.3 MRLDS Gateway

4.3.1 MRLDS Gateway Setup on I/O Network

Modbus versions of the MRLDS must be connected to the 810-3040 MRLDS Gateway. The MRLDS Gateway can be mapped in either of two ways: it can be set up on I/O Net as an IRLDS application or as a 16AI board. Select by setting the Gateway's dip switch #5 to the OFF or ON position (Figure 4-6).

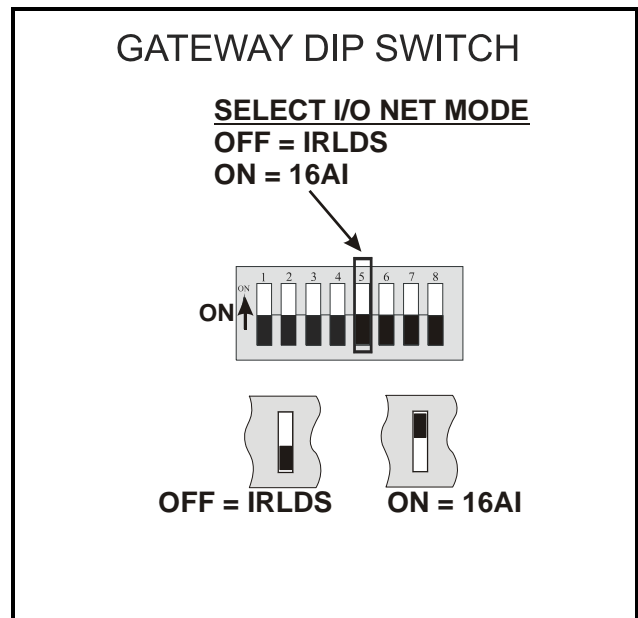

Figure 4-6 - I/O Network Modes

4.3.2 Gateway Connections

Up to 12 MRLDS units may be connected to the Gate-

way board (P/N 810-3040). The Gateway board can interface with a site controller as a 16AI or as an IRLDS. If the site controller is an Einstein or E2, it is recommended to interface them as an IRLDS. Multiple Gateways can be used, each with up to 12 connected MRLDS units.

4.3.3 The Gateway Board

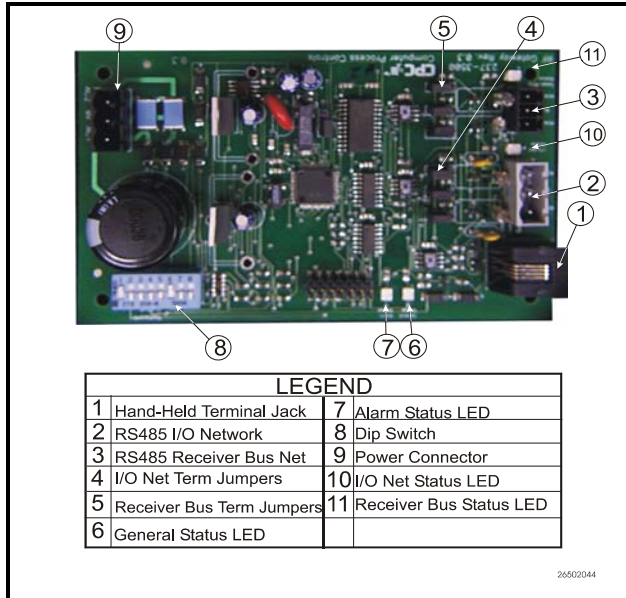

Figure 4-7 - MRLDS Gateway Board Layout (810-3040)



CAUTION: Before installing the Gateway board, verify that jumper JP7 (if present on the board) is set to the “NORMAL” position (not the “TEST” position). Operating the Gateway with the jumper in “TEST” position may cause board damage.

The Gateway Board communicates with the MRLDS via the Modbus network, which is connected to the Gateway’s “Receiver Bus” network terminal. The Gateway communicates with the E2 via the RS485 I/O Network.

4.3.4 Powering the Gateway Board

Input Voltage	24VAC, Class 2, Center-Tapped 50/60Hz
Power	5VA

Table 4-4 - Gateway Power Requirements

The Gateway board requires 24VAC power from a Class 2 center-tapped transformer. Retail Solutions supplies several sizes of center-tapped transformers for powering multiple 16AIs, 8ROs, and other RS485 peripheral boards.

Figure 4-8 shows how to connect the 56VA and 80VA transformers to the Gateway power connector.

	Three-Board	Six-Board
P/N	640-0056	640-0080
Power Rating	56 VA	80 VA

Table 4-5 - Power Ratings for CPC Transformers

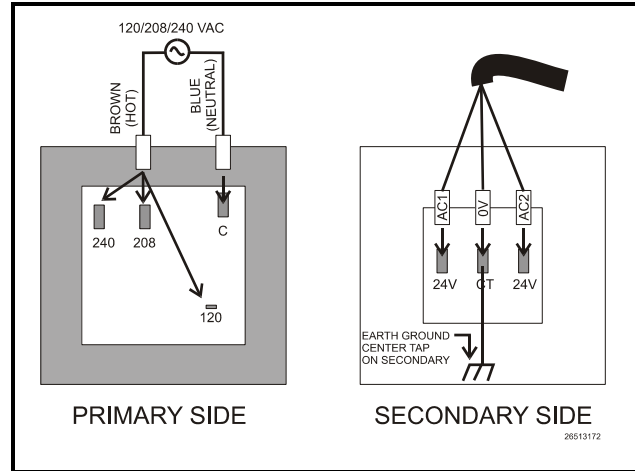

Figure 4-8 - Pinout for the 56VA (640-0056) and 80VA (640-0080) Transformers



CAUTION: The MRLDS unit requires a separate Class 2, 24VAC, 10VA power supply.

4.3.5 Connecting the Gateway Board to the Einstein or REFLECS Network

Each E2, Einstein, or REFLECS site controller that will communicate with one or more MRLDS units must have a Gateway Board installed on its RS485 I/O Network. For Einstein controllers, this means the Gateway will be installed on the RS485 I/O Network; for RMCC, BEC, BCU, and other REFLECS products, the Gateway will be installed on the COM A or COM D network.

4.3.6 Wire Connections

Using shielded three-conductor network cable (Belden #8641 or equivalent), connect the RS485 I/O Network wire to the three-terminal connector on the Gateway board as shown in Figure 4-9. For further information about how RS485 networks are configured, refer to your site

controller's user manual.

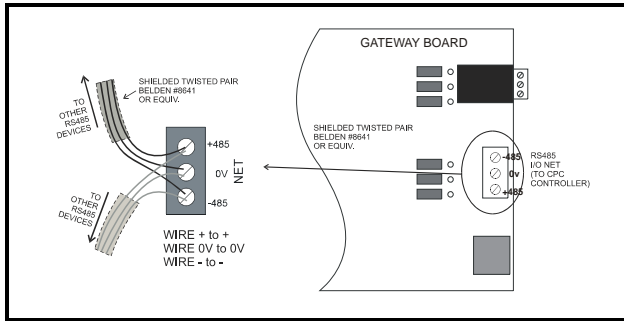

Figure 4-9 - Connecting the Gateway to the E2 RS485 Network

To connect the Gateway to an MRLDS, feed the wires through the rectangular opening in the sensor base as indicated in *Figure 1-1*. Locate the RS485 connector and secure the wire leads to the connector orienting them as shown in *Figure 4-10*. Connect multiple MRLDS units in a daisy-chain configuration as shown in *Figure 4-1*.

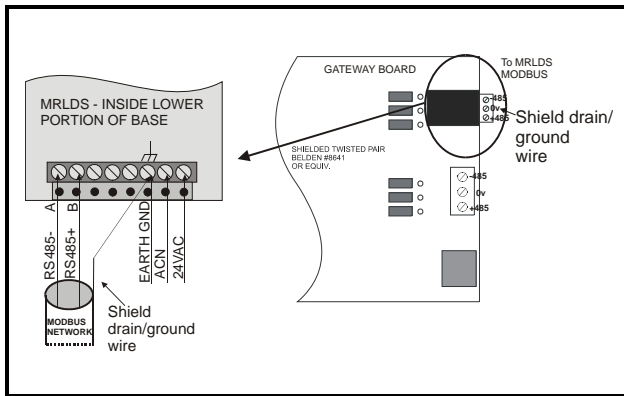

Figure 4-10 - Connecting the Gateway to MODBUS

4.3.7 Termination Settings

As part of a site controller's RS485 I/O (COM A or COM D) Network, a Gateway must be terminated if it is the end device of a daisy chain. The Gateway on the Modbus Network should always be terminated and always located at the end of the daisy chain.

Refer to the site controller's user manual for information about daisy chain networks and how they are terminated.

To terminate the Gateway (the Modbus jumpers should always be terminated on the Gateway), set the receiver bus jumpers to the RIGHT position (*Figure 4-11*).

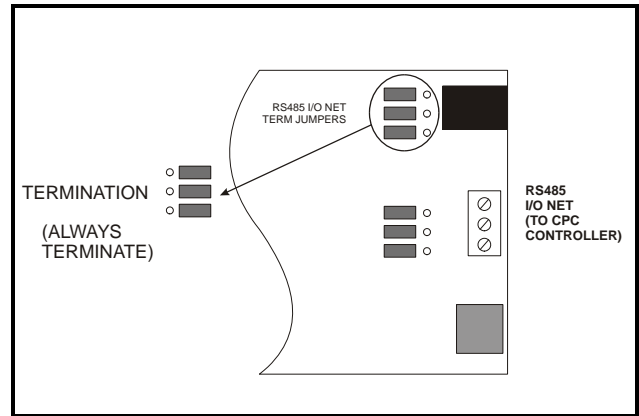

Figure 4-11 -MRLDS Gateway Termination

4.3.8 Gateway Board I/O Net Addressing

Set the address on the I/O Network with switches 1-4. There can be more than one MRLDS Gateway with each supporting up to 12 MRLDS units.

Switch 5 indicates whether the MRLDS will be mapped as an IRLDS or 16AI. Set switch 5 to the OFF position for IRLDS emulation or to the ON position for 16AI emulation.

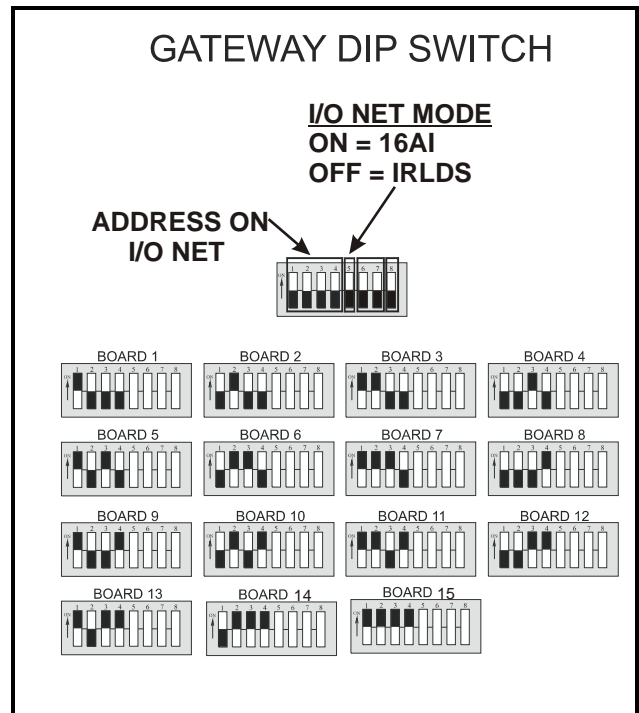

Figure 4-12 - Network Layout Example

4.3.9 Setting the Baud Rate Dip Switches

Dip switches 6 and 7 control the baud rate at which the Gateway communicates with the site controller on the RS485 Network. These switches must be set to the same baud rate setting as the controller you are using (Einstein, RMCC, or E2), and defaults to 9600 baud. Dip switch 8 controls the baud rate at which the Gateway communicates with the MRLDS. For 9600 baud, set dip switch 8 to the OFF position. For 19200 baud, set dip switch 8 to the ON position (always use 19200 baud for MRLDS).

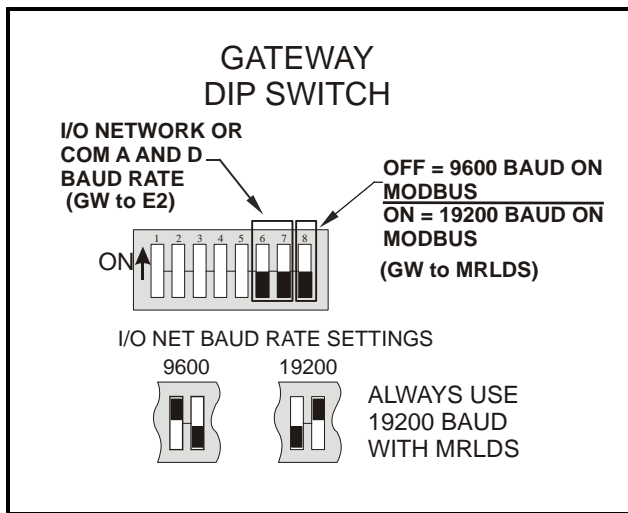

Figure 4-13 - Dip Switch Settings for Gateway Baud Rate

4.3.10 Hand-Held Terminal Settings

The hand-held terminal can be used to view status information, enable unit addresses, and is connected directly to the Gateway board via the hand-held terminal jack.

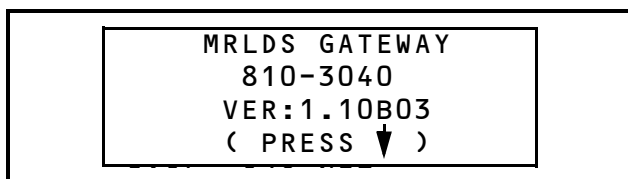

Figure 4-14 - MRLDS HHT Home Screen

4.3.10.1 MRLDS Setup

From the HHT Home screen (F1), press the down arrow key to navigate to the *Baud Rate/Address screen* (Figure 4-15).

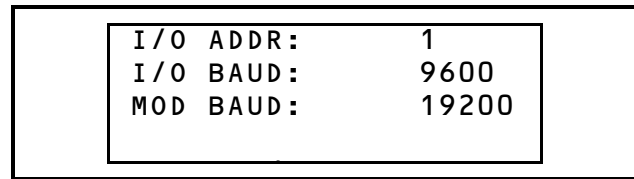

Figure 4-15 - Baud Rate/Address Screen

The *Baud Rate/Address screen* displays the Gateway I/O Network address (I/O ADDR), the I/O Network baud rate between the Gateway and the E2 (I/O BAUD), and the Modbus baud rate between the Gateway and the MRLDS devices (MOD BAUD).

4.3.10.2 Select Screen

Press the down arrow again to navigate to the *Select screen* (or press F2). From the *Select screen* you can see status, setup, and firmware version information.

To select, press the right arrow until it appears next to SELECT and press 1, 2, or 3 in the list. Press the down arrow twice to move to the desired screen.

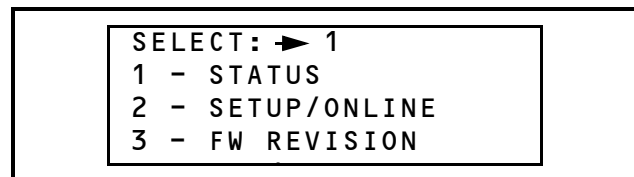

Figure 4-16 - Select Screen

4.3.10.3 Status Screen

1 - The *Status screen* displays general status information about the MRLDS such as device numbering, count information (gas concentration in PPM), the type of refrigerant gas being monitored (MRLDS jumpers set by the user), and whether an alarm has been issued. An alarm indicates an MRLDS failure and that the MRLDS should be replaced. Call the Retail Solutions Service Department (770-425-2724) to verify if the MRLDS unit should be replaced.

Possible states (ST) are:

- WARMUP - MRLDS is warming up.
- NORMAL - MRLDS has completed warm-up and is operating normally.
- OFFLINE - MRLDS has lost communication.
- UNUSED - This address is not being used.
- FAIL - MRLDS has reported a fail state. Check the ALM field for specification.

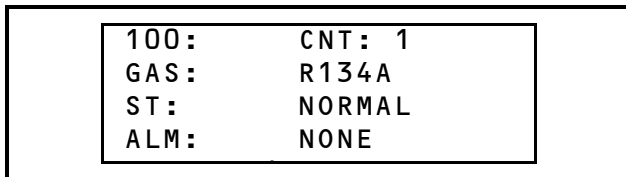

Figure 4-17 - Status Screen

NOTE: If the HHT displays any type of alarm, contact the Retail Solutions Service Department (770-425-2724) to verify if the MRLDS unit should be replaced.

4.3.10.4 Setup/Online Screen

2 - The *Setup/Online screen* displays the addressing of the devices and whether they are enabled. Press the right/left arrows to select the first address in the list. Toggle the minus button to enable the first address in the list (*Figure 4-18*). If communication is established, the screen will show “ON-L” indicating the unit is set up and online.

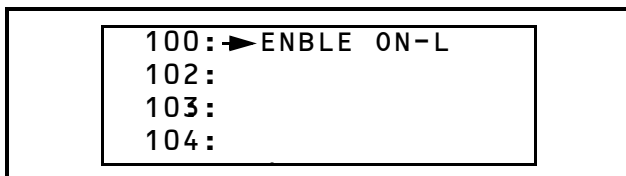

Figure 4-18 - Setup/Online Screen

NOTE: For IRLDS mode, disable unused addresses by toggling the minus key to *DISABLE*. Unused addresses that have not been disabled may cause a false failure on the E2.

4.3.10.5 Firmware Revision Screen

3 - The *Firmware Revision screen* displays the address of the MRLDS unit with its associated firmware revision.

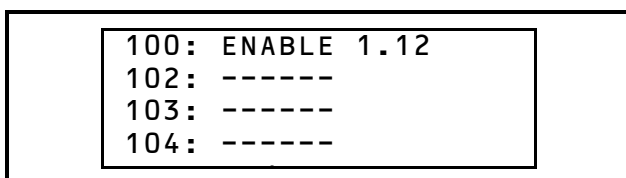

Figure 4-19 - Firmware Revision Screen

4.3.11 Gateway Troubleshooting

If there is an issue with the Gateway board, the HHT Home screen (F1) can give status indicators to report the issue. The Home screen will display a warning if there is a failure associated with the I/O Network or flash on the Gateway board. Select the HHT *Status screen* to view status information for each MRLDS unit.

4.4 Controller Setup for Modbus MRLDS

4.4.1 Mapping The MRLDS as an IRLDS Application

To set up communication on the I/O Network as an IRLDS application:

1. Log in to the E2 controller.
2. Press the **Menu** button to open the Main Menu.
3. Select **7. System Configuration**.
4. Select **7. Network Setup**.
5. Select **2. Connected I/O Boards & Controllers** and add the desired number of MRLDS Gateways as **IRLDS** under **I/O Net Devices**. Up to 12 units can be connected to each Gateway.
6. Press the  (Back) button and select **1. Online Status** (Alt + N) to check the status.
7. Go into the IRLDS application under General Setup and add the number of MRLDS units (**Num Channels** field) connected to the Gateway.

4.4.2 Designating MRLDS as a 16AI Board

1. Log in to the E2 controller.
2. Press the **Menu** button to open the Main Menu.
3. Select **7. System Configuration**.
4. Select **7. Network Setup**.
5. Select **2. Connected I/O Boards & Controllers** and add the desired number of 16AI boards under **I/O Net Devices**.
6. Press the  (Back) button and select **1. Online Status** (Alt + N) to check the status.

For mapping the MRLDS unit as a 16AI board, first set dip switch #5 on the Gateway board to the ON position.

Follow **Steps 1-6** above, but for **Step 6** select the number of 16AI boards to equal the number of MRLDS Gate-

ways.

Navigate to the controller's Input Status screen and highlight the board and point that you wish to map. Press F1 to go to the Input Setup screen for that board/point. Each point will increase incrementally to correspond with each board. (For example, where the MRLDS is address 1 and the MRLDS address is 100, use board 1, point 1. For an MRLDS address of 101, use point 2.)

4.4.3 E2/Einstein Controllers

Next, set up the following parameters on the Input Setup screen:

- Sensor Type: **Linear**
- Low End Point: **0.00000**
- Select Eng. Units: **PPM**
- HighEnd Point: **4.80000**
- High Eng. Units: **1200.0000**

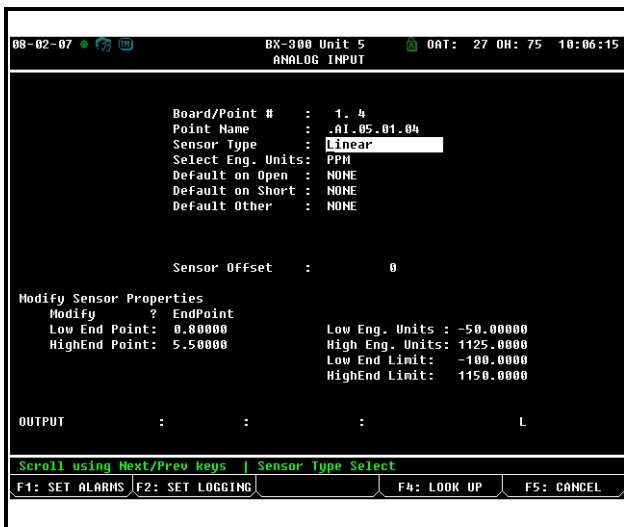

Figure 4-20 - Analog Input Screen Settings Example for E2

4.4.4 RMCC Controllers Version 2.1 and Newer

4.4.4.1 REFLECS Setup for IRLDS IIs

Set dip switch 8 to ON and follow the steps for setting up IRLDS IIs through the REFLECS controller interface:

1. Log on.
2. Press 7 for **Configuration** to reach the **CONFIGURATION** screen.

Input Definitions should be set here to show how the sensor control is linked to the zone. The number of devices and IRLDS IIs are connected to the Gateway and enabled is the number of address slots the Gateway will use.

3. Press 1 for **Input Definitions** to reach the **INPUT DEFINITIONS** screen.
4. Pressing the down arrow several times will get you to the input list of **SENS01-48. Bd** (board) is the address of the Gateway, **Pt** (point) is the zone and allows you to define where the sensor input comes from.

The board number for the IRLDS II setup is the address of the Gateway. If there are three or less IRLDS II controllers connected to a Gateway, the Gateway address = the IRLDS II address. However, if there are more than three IRLDS controllers, the second Gateway address will be the one entered for the board number, but the IRLDS II controllers are set 1 to 3 on the second Gateway.

5. Press 0 (zero) to go back to the **CONFIGURATION** screen.
6. Press 7 for **I/O Brd Setup** to reach the **I/O BOARD MENU** screen.
7. Press 2 to **Set Device #'s**.

The Gateway will react as three 16AI boards. The number of IRLDS II controllers plus the real number of 16AIs = the total number of 16AIs to enter in the next step:

8. At the **I/O BOARD DEVICE NUMBERS** screen, press the down arrow key to reach **Number 16AI Boards** and enter the number of how many 16AI boards and IRLDS II controllers there are. Press Enter.
9. Arrow down to the **I/O BOARD MENU** and press 0 (zero) twice to go back to the **MAIN MENU** screen.
10. Press 4 for **Sensor Control**.
11. Press 2 for **Setup**--up to 48 sensor control programs are allowed. Select one of the 48 units and press Enter to reach the **SENSOR SETUP** screen.
12. Press the right arrow to move to the **Name**

field to change the name, and press the down or right arrow to move to the (sensor) **Type** field. Use the “.” and “—” keys to scroll through the options and select **IRLDS**. (The Gain and Offset parameters are automatically configured for you.)

- Use the arrow keys to move off the active fields and press 0 (zero) twice to go back to the main screen.

4.4.5 BEC and RMCC Controllers Less Than Version 2.1

4.4.5.1 Input Definitions

INPUT DEFINITIONS						12:00
Input	Bd	Pt	Input	Bd	Pt	
SENS01	01	01	SENS02	01	01	
SENS03	00	00	SENS04	00	00	
SENS05	00	00	SENS06	00	00	
SENS07	00	00	SENS08	00	00	

↑=PREV ↓=NEXT →=SET-DATA 0=MENU

Locate the screens in the BEC or RMCC that are used to define input board and points. This is usually achieved by pressing 7 then 1 from the Main Menu. Press the DOWN ARROW key several times until the SENS01-SENS08 inputs are shown.

The 16AI connected to the IRLDS’s output terminals must be set up in the REFLECS’s system software. If the 16AI was given a unique board number by setting the dip switch S3, and wired to the terminals so that each zone number corresponds to a 16AI point number (zone 01 connected to point 01, for example), these board and point addresses must now be entered into the REFLECS.

The screen above shows how the board and point addresses for zone 1 would be set up for a 16AI board numbered 1. Both SENS01 and SENS02 are set up as 01:01 so that SENS01 can monitor concentration and SENS02 can monitor fault status.

Set up the remaining sensors using the instructions given above. For each point on the 16AI, set up two sensors with the same addresses.

4.4.5.2 Sensor Setup

SENSOR SETUP		12:00
#: 01	Stat us: OFF	Name: REFR LK ZN 01
Type: Li near		
(T)mp (1)00 (5)00 (R)fLeak (K)Vat t		
(H)um (2)00 (D)ig (L)i near (Q)Lev		
(6)450 Temp Dew Pnt		
Loggi ng I nt er val (H:M:SS):	00:03:00	

↑=PREV ↓=NEXT →=SET-DATA 0=MENU

Locate the screen in the BEC or RMCC where sensors are set up. This is usually a menu option in the Sensors Menu, which may be reached from the Main Menu.

The 0-4.8V signal is a linear signal representing a measured concentration of 0-1200 PPM, and a voltage of 5.0V indicates a fault. In order for the REFLECS to read these voltages correctly, the REFLECS sensor inputs must be configured as linear sensors.

Name

A name for the sensor input may be entered in the Name field. Since each IRLDS zone is set up with two REFLECS sensor inputs, choose names for each input that distinguish the input’s function. For example, the sensor input set up to read leak concentrations on zone 1 should have a name like REFR LK ZN 01, and the input set up to monitor fault status should have a name like FAULT ZN 01.

Type

All sensor inputs connected to an IRLDS should be set up as linear sensors. Enter (L)inear in the Type field.

Logging Interval

The logging interval is the amount of time between log entries in the REFLECS’s Data Log.

When choosing a logging interval, keep in mind the amount of time it takes an IRLDS to go through an entire cycle of samplings. For example, a 16-valve IRLDS with 30 second sampling times for each zone takes a total of eight minutes to sample all zones. Choosing a logging interval smaller than the IRLDS’s cycle time will simply clutter the REFLECS data log with multiple copies of the same sample.

4.4.5.3 Sensor Setpoints

SENSOR SETPOINTS		LI NEAR I NPUT	12:00
#: 01	Stat us: OFF	Name: REFR LK ZN 01	
St ay ON for: 000 min	Eng. Uni t: PPM		
Usi ng Di ff Of 01	00 00		
0 Of 0	0 0		
Gain 250	Of f set: 00000 mv		
ON: 0	Di y: 0000	OFF: 0	Di y: 0000

↑=PREV ↓=NEXT →=SET-DATA 0=MENU

Locate the screen in the BEC or RMCC where sensor set points are specified. This is usually a menu option in the Sensors Menu, which may be reached from the Main Menu.

After the linear sensors have been set up, the REFLECS must be told how to interpret the linear voltage given by the IRLDS.

Eng. Unit

The REFLECS does not require any specific engineering unit to be specified for sensor values. However, for easier reading of status screens and data logs, “PPM” should be entered for sensor inputs that read concentration, and

“MV” should be entered for sensor inputs that read fault status.

Gain and Offset

Since the output terminals emit one volt for every 250 PPM of refrigerant detected, the gain for the refrigerant leak sensors must be set to 250 and the Offset to 0.

The sensors configured to detect faults must be given a gain of 1000; this way, the REFLECS can be set up to alarm whenever it detects a 5000 mV signal.

4.4.5.4 Alarm Setpoints

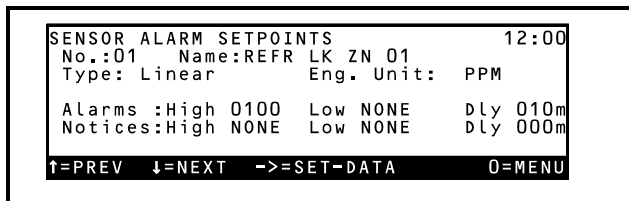

Locate the screen in the BEC or RMCC where sensor alarm set points are specified. This is usually a menu option in the Sensors Menu, which may be reached from the Main Menu.

The REFLECS should now be capable of interpreting the 0-4.8V output voltage as a refrigerant concentration of 0-1200 PPM and the 5V output voltage as a fault. The desired alarm set points must now be specified. When set up correctly, alarms will appear in the REFLECS Alarm log as “Hi Sensor” alarms (refer to the REFLECS manual for alarm descriptions).

Alarms: High

In this field, specify a high alarm setpoint for refrigerant leak alarms between 0 and 1200 PPM. For fault status alarms, enter a setpoint of 4960 mV (slightly below 5V, as a precautionary measure).

Alarms/Notices Dly

The value entered in the Alarms Dly field is the number of minutes the sensor reading must be above the Alarms:High setpoint before the REFLECS may generate a leak alarm

When choosing an alarm delay, keep in mind the amount of time it takes an IRLDS to complete a sampling cycle. For example, a 16-valve IRLDS with 30 second sampling times for each zone takes a total of eight minutes to sample all zones. Choosing an alarm delay smaller than the IRLDS’s cycle time will cause an alarm to be generated after only one high reading is taken.

5 Diagnostics

5.1 MRLDS LED Indicators

The MRLDS has three LEDs for quick status indication.

MRLDS LEDs	STATUS INDICATION
Green	Lights during normal operation
Red	Flashes at 0.5 Hz during start-up Turns ON solid if concentration reading exceeds 50 PPM
Yellow	Flashes at 0.5 Hz if power supplied is outside set limits Turns ON solid during other fault conditions

Table 5-1 - MRLDS LED Status

For analog output models, a fault is signaled by setting the voltage to 0.5V, which indicates the MRLDS should be replaced. Call the Retail Solutions Service Department (770-425-2724) to verify if the MRLDS unit should be replaced.

5.2 E2 Alarming

5.2.1 IRLDS Mode

If any one or all of the MRLDS sensors encounters a problem, the IRLDS application will alarm and all cell outputs will show NONE. For details on which individual unit is in alarm, go to the MRLDS Gateway and check the Status screen on the HHT.

5.2.2 16AI Mode

If an MRLDS has lost communication, the input will go to 1250 PPM, which should force an alarm if enabled. If all MRLDS sensors lose communication, the 16AI will go offline. Check the Status screen on the HHT for details.

5.3 Linearity Settings for Supported Refrigerants

Factors such as air movement and the proximity of the sensor to the leak will usually have a greater influence on the reading (Rdg) than the differences in the linearity (accuracy) of the various supported refrigerants, so the alarm limits should not have to be adjusted. However, depending on the refrigerant selection, you may want to fine tune the alarm limit by increasing the limit for the refrigerants with linearity ranges in the 25-50 PPM range that are greater than +/- 10 PPM to avoid alarming at too low of a count.

If the linearity range is greater than +/- 10 PPM you would increase the alarm limit by the amount it is above +/-10 PPM. For example, if your were using R-410A you may want to increase the alarm limit by 5 PPM, so an alarm limit for R-410A of 40 PPM would be increased to 45 PPM.

Linearity	R-22	R-134a	R-404A	R-407A	R-407C	R-410A	R-422A	R-422D	R-427A	R-507
25-50 PPM	+/-10 PPM	+/-10 PPM	+/-10 PPM	+/-15 PPM	+/-17 PPM	+/-15 PPM	+/-12 PPM	+/-15 PPM	+/-15 PPM	+/-17 PPM
60-1000 PPM	+/-20% of Rdg	+/-20% of Rdg	+/-20% of Rdg	+/-30% of Rdg	+/-45% of Rdg	+/-30% of Rdg	+/-25% of Rdg	+/-30% of Rdg	+/-30% of Rdg	+/-45% of Rdg

Table 5-2 - Linearity Settings for Supported Refrigerants

