



SNOW BLOWER

Published 07/05

Part No. 5042C

OPERATOR'S MANUAL



This Operator's Manual is an integral part of the safe operation of this machine and must be maintained with the unit at all times. **READ, UNDERSTAND, and FOLLOW** the Safety and Operation Instructions contained in this manual before operating the equipment.

ATENCIÓN!

LEA EL INSTRUCTIVO

Si No Lee Ingles, Pida Ayuda a Alguien Que Si Lo Lea Para Que le Traduzca las Medidas de Seguridad.

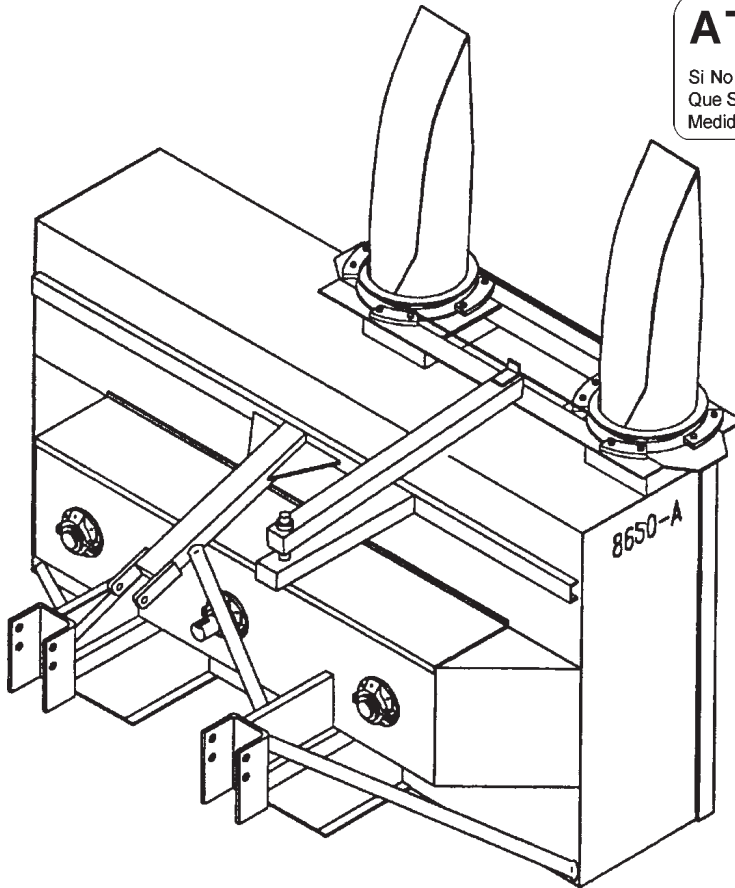

ALAMO INDUSTRIAL

1502 E. Walnut
Seguin, Texas 78156
830-372-3551



© 2005 Alamo Group Inc.

\$0.00

TO THE OWNER/OPERATOR/DEALER

All implements with moving parts are potentially hazardous. There is no substitute for a cautious, safe-minded operator who recognizes the potential hazards and follows reasonable safety practices. The manufacturer has designed this implement to be used with all its safety equipment properly attached to minimize the chance of accidents.





BEFORE YOU START!!

Read the safety messages on the implement and shown in your manual.
Observe the rules of safety and common sense!







DANGER

FAILING TO FOLLOW SAFETY MESSAGES AND OPERATING INSTRUCTIONS CAN CAUSE SERIOUS BODILY INJURY OR EVEN DEATH TO OPERATOR AND OTHERS IN THE AREA.

<p>1.</p> 	<p>2. NO RIDERS, NO CHILDREN OPERATORS</p> 	<p>3. USE SEATBELT, ROPS AND PPE</p> 	<p>4. BLOCK UP SECURELY BEFORE WORKING UNDER.</p> 
---	--	---	---

- Study and understand Operator's Manuals, Safety Signs, and Instructional Decals for tractor & implement to prevent misuse, abuse, & accidents. Learn how to stop engine suddenly in an emergency. Be alert for Passersby and Especially children.
- Allow no children on or near implement or tractor. Allow no riders on tractor or implement. Falling off can cause serious injury or death from being run over by tractor or implement or contact with rotating components..
- Operate only with tractor having Roll-Over Protective Structure (ROPS) and with seatbelt fastened securely and snugly to prevent injury and possible death from falling off or tractor overturn. Personal Protective Equipment such as Hard Hat, Safety Glasses, Safety Shoes, and Ear Plugs are recommended.
- Block up or support raised machine and all lifted components securely before putting hands or feet under or working underneath any lifted component to prevent crushing injury or even death from sudden inadvertent Dropping. Make certain that area is clear before lowering.
- Before transporting, put Lift Lever in Lift (Detent) position and follow traffic codes. Slow down at night, in turns and on hillsides. .
- Make certain that SMV sign, Warning Lights, and Reflectors are clearly visible.
- Never operate with implement raised off ground to reduce possibility of injury from objects thrown under Implement structure.
- Before dismounting, secure implement in transport position or lower to ground. Stop PTO, put tractor in park or set Brake, stop engine and remove key. Never mount or dismount a moving vehicle. Crushing from run over may can use injury or death

<p>5. TRANSPORT SAFELY,</p> 	<p>6. USE SMV, LIGHTS, & REFLECTORS.</p> 	<p>7. DO NOT OPERATE WITH UNIT RAISED</p> 	<p>8. DO NOT MOUNT OR DISMOUNT WHILE MOVING.</p> 
---	--	--	--

226-331

WARRANTY INFORMATION:

Read and understand the complete Warranty Statement found in this Manual. Fill out the Warranty Registration Form in full and return it to Alamo within 30 Days. Make certain the Serial Number of the Machine is recorded on the Warranty Card and on the Warranty Form that you retain.

TABLE OF CONTENTS

SAFETY SECTION

Safety Information	1-2
Safety Decal Location	1-14
Safety Decals	1-16
Federal Laws and Regulations	1-23

INTRODUCTION SECTION 2-1

ASSEMBLY SECTION 3-1

Hydraulic Chute Rotation Cylinder	3-2
Hitch Assemblies	3-3

OPERATION SECTION 4-1

MAINTENANCE SECTION 5-1

Nuts and Bolts	5-2
Drive Chain	5-2
Shear Bolt	5-2
PTO Lubrication	5-3
Spout Bracket Lubrication	5-3
Fan Lubrication	5-4
Oil Reservoir	5-4
Grease Schedule	5-5
Storage	5-5

DEALER'S PREDELIVERY SERVICE GUIDE

for the ALAMO INDUSTRIAL 8650A

DETAILS OF ITEMS LISTED BELOW ARE COVERED IN THIS OPERATOR'S MANUAL

- _____ Set up machine as outlined in the shipping instructions attached to these instructions.
 - _____ Check that all safety decals are in good condition, replace if necessary.
 - _____ Check that gearboxes have been filled with oil.
 - _____ Check that all grease fittings have been lubricated.
-

DEALER'S DELIVERY GUIDE

- _____ Mounting and removal from tractor
 - _____ Operation
 - _____ Adjustments
 - _____ Lubrication
 - _____ Maintenance
 - _____ Operator's safety precautions
 - _____ User's responsibility and warranty
 - _____ Operator's manual delivered to owner
 - _____ Operator instructed on contents of owner's manual
-

SAFETY SECTION

SAFETY

General Safety Instructions and Practices

A safe and careful operator is the best operator. Safety is of primary importance to the manufacturer and should be to the owner/operator. Most accidents can be avoided by being aware of your equipment, your surroundings, and observing certain precautions. The first section of this manual includes a list of Safety Messages that, if followed, will help protect the operator and bystanders from injury or death. Read and understand these Safety Messages before assembling, operating or servicing this implement. This equipment should only be operated by those persons who have read the Manual, who are responsible and trained, and who know how to do so safely and responsibly.

The Safety Alert Symbol combined with a Signal Word, as seen below, is used throughout this manual and on decals which are attached to the equipment. The Safety Alert Symbol means: **“ATTENTION! BECOME ALERT! YOUR SAFETY IS INVOLVED!”** The Symbol and Signal Word are intended to warn the owner/operator of impending hazards and the degree of possible injury faced when operating this equipment..

Practice all usual and customary safe working precautions and above all---remember safety is up to YOU. Only YOU can prevent serious injury or death from unsafe practices.

CAUTION!



The lowest level of Safety Message; warns of possible injury. Decals located on the Equipment with this Signal Word are Black and Yellow.

WARNING!



Serious injury or possible death! Decals are Black and Orange.

DANGER!



Imminent death/critical injury. Decals are Red and White. (SG-1)

READ, UNDERSTAND, and FOLLOW the following Safety Messages. Serious injury or death may occur unless care is taken to follow the warnings and instructions stated in the Safety Messages. Always use good common sense to avoid hazards.

(SG-2)

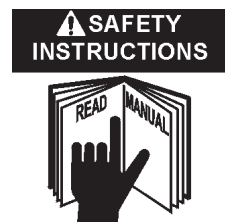

SAFETY

PELIGRO!



Si no lee Ingles, pida ayuda a alguien que si lo lea para que le traduzca las medidas de seguridad. (SG-3)



!LEA EL INSTRUCTIVO!

WARNING!



Engine Exhaust, some of its constituents, and certain vehicle components contain or emit chemicals known to the state of California to cause cancer and birth defects or other reproductive

WARNING!



Battery posts, terminals and related accessories contain lead and lead compounds, chemicals known to the state of California to cause cancer and birth defects or other reproductive harm. Wash Hands after handling. (SG-31)

Operator Safety Instructions and Practices

WARNING!



The rotating parts of this machine continue to rotate even after the PTO has been turned off. The operator should remain in his seat for 60 seconds after the brake has been set, the PTO disengaged, the tractor turned off, and all evidence of rotation has ceased. (S3PT-10)

“Wait a minute...Save a life!”

DANGER!



Never crawl under a raised Implement supported solely by the Tractor 3-Point hitch. Release of the control lever or mechanical failure will result in the Implement falling and possible injury or death. Always securely block up the Implement before crawling underneath to perform repairs and service. (S3PT-19)

DANGER!



Never operate the Tractor or Implement until you have read and completely understand this Manual, the Tractor Operator's Manual, and each of the Safety Messages found in the Manual or on the Tractor and Implement. Learn how to stop the tractor engine suddenly in an emergency. Never allow inexperienced or untrained personnel too operate the Tractor and Implement without supervision. Make sure the operator has fully read and understood the manuals prior to operation. (SG-4)



WARNING!



The operator and all support personnel should wear hard hats, safety shoes, safety glasses, and proper hearing protection at all times for protection from injury including injury from items thrown by the equipment. (SG-16)

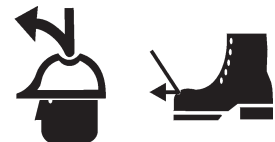

SAFETY

SAFETY

CAUTION!



PROLONGED EXPOSURE TO LOUD NOISE MAY CAUSE PERMANENT HEARING LOSS! Tractors with or without an Implement attached can often be noisy enough to cause permanent hearing loss. We recommend that you always wear hearing protection if the noise in the Operator's position exceeds 80db. Noise over 85db over an extended period of time will cause severe hearing loss. Noise over 90db adjacent to the Operator over an extended period of time will cause permanent or total hearing loss. *Note:* Hearing loss from loud noise [from tractors, chain saws, radios, and other such sources close to the ear] is cumulative over a lifetime without hope of natural recovery. (SG-17)



WARNING!



Always read carefully and comply fully with the manufacturers instructions when handling oil, solvents, cleansers, and any other chemical agent. (SG-22)



DANGER!



KEEP AWAY FROM ROTATING ELEMENTS to prevent entanglement and possible serious injury or death. (SG-24)



DANGER!



Never allow children to play on or around Tractor or Implement. Children can slip or fall off the Equipment and be injured or killed. Children can cause the Implement to shift or fall crushing themselves or others. (SG-25)

DANGER!



NEVER use drugs or alcohol immediately before or while operating the Tractor and Implement. Drugs and alcohol will affect an operator's alertness and coordination and therefore affect the operator's ability to operate the equipment safely. Before operating the Tractor or Implement, an operator on prescription or over-the-counter medication must consult a medical professional regarding any side effects of the medication that would hinder their ability to operate the Equipment safely. **NEVER** knowingly allow anyone to operate this equipment when their alertness or coordination is impaired. Serious injury or death to the operator or others could result if the operator is under the influence of drugs or alcohol. (SG-27)



WARNING!



Prolonged operation may cause operator boredom and fatigue affecting safe operation. Take scheduled work breaks to help prevent these potentially impaired operating conditions. Never operate the Implement and Tractor in a fatigued or bored mental state which impairs proper and safe operation. (SG-32)

SAFETY

DANGER!



DO NOT operate this Implement on a Tractor that is not properly maintained. Should a mechanical or Tractor control failure occur while operating, immediately shut down the Tractor and perform repairs before resuming operation. Serious injury and possible death could occur from not maintaining this Implement and Tractor in good operating condition. (SG-36)

DANGER!



Do Not approach the front of the snow blower while the fan is rotating. Contact with the rotating fan can result in serious injury or even death. Stay away until all motion has stopped and the snow blower is securely blocked up before removing material, performing service, and making repairs. (SSB-05a)

DANGER!



Do not put hands or feet near the rotating fan. Fan contact can result in serious injury or even death. Stay away until all motion has stopped and the snow blower is securely blocked up before removing material, performing service, and making repairs. (SSB-6)



DANGER!



Do not operate the implement while wearing loose fitting clothing. Entanglement of the clothing with the rotating elements can result in serious injury or even death. Stay clear of all rotating elements at all times. (SSP-3)

Connecting or Disconnecting Implement Safety Instructions and Practices

WARNING!



DO NOT use a PTO adapter to attach a non-matching Implement driveline to a Tractor PTO. Use of an adapter can double the operating speed of the Mower resulting in excessive vibration, thrown objects, and blade and mower failure. Adapter use will also change the working length of the driveline exposing unshielded driveline areas. Serious bodily injury and/or equipment failure can result from using a PTO adapter. Consult an authorized dealer for assistance if the Implement driveline does not match the Tractor PTO. (S3PT-14)

DANGER!



Always shut the Tractor completely down, place the transmission in park, and set the parking brake before you or anyone else attempts to connect or disconnect the Implement and Tractor hitches. (S3PT-15)

WARNING!



When attaching the Implement input driveline to the Tractor PTO, it is important that the connecting yoke spring activated locking collar slides freely and the locking balls are seated securely in the groove on the Tractor PTO shaft. A driveline not attached correctly to the Tractor PTO shaft could come loose and result in personal injury and damage to the Implement. (S3PT-17)

WARNING!



Before operating the Mower, check to make sure the Implement input driveline will not bottom out or become disengaged. Bottoming out occurs when the inner shaft penetrates the outer housing until the assembly becomes solid-it can shorten no more. Bottoming out can cause serious damage to the Tractor PTO by pushing the PTO into the Tractor and through the support bearings or downward onto the PTO shaft, breaking it off. A broken drive line can cause personal injury. (S3PT-18)

SAFETY

SAFETY

WARNING!



Only use Tractors equipped with a ROPS cab and seatbelt with this equipment. Always wear your seat belts. Serious injury or even death could result from loss of control of the tractor or falling off. (SSB-18)

Equipment Operation Safety Instructions and Practices

DANGER!



This Implement is wider than the Tractor. Be careful when operating or transporting this equipment to prevent the Implement from running into or striking sign posts, guard rails, concrete abutments or other solid objects. Such an impact could cause the Implement and Tractor to pivot violently resulting in loss of steering control, serious injury, or even death. Never allow the Implement to contact obstacles. (S3PT-12)

WARNING!



Operate this Equipment only with a Tractor equipped with an approved roll-over-protective system (ROPS). Always wear seat belts. Serious injury or even death could result from falling off the tractor--particularly during a turnover when the operator could be pinned under the ROPS.

(SG-7)



DANGER!



BEFORE leaving the tractor seat, always engage the brake and/or set the tractor transmission in parking gear, disengage the PTO, stop the engine, remove the key, and wait for all moving parts to stop. Place the tractor shift lever into a low range or parking gear to prevent the tractor from rolling. Never dismount a Tractor that is moving or while the engine is running. Operate the Tractor controls from the tractor seat only. (SG-9)

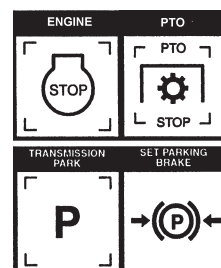

DANGER!



Never allow children or other persons to ride on the Tractor or Implement. Falling off can result in serious injury or death. (SG-10)



DANGER!



Never allow children to operate, ride on, or come close to the Tractor or Implement. Usually, 16-17 year-old children who are mature and responsible can operate the implement with adult supervision, if they have read and understand the Operator's Manuals, been trained in safe operation of the tractor and Implement, and are physically large enough to reach and operate the controls easily. (SG-11)



WARNING!



Do not mount the Tractor while the tractor is moving. Mount the Tractor only when the Tractor and all moving parts are completely stopped. (SG-12)



SAFETY

SAFETY

DANGER!



Start tractor only when properly seated in the Tractor seat. Starting a tractor in gear can result in injury or death. Read the Tractor operators manual for proper starting instructions. (SG-13)



DANGER!



Do not operate this Equipment with hydraulic oil or fuel leaking. Oil and fuel are expensive and their presence could present a hazard. Do not check for leaks with your hand! High-pressure oil streams from breaks in the line could penetrate the skin and cause tissue damage including gangrene. To check for a hose leak, SHUT the tractor ENGINE OFF and remove all hydraulic pressure. Wear oil impenetrable gloves, safety glasses and use Card-board to check for evidence of oil leaks. If you suspect a leak, REMOVE the HOSE and have it tested at a Dealer. If oil does penetrate the skin, have the injury treated immediately by a physician knowledgeable and skilled in this procedure. (SG-15)



DANGER!



Never run the tractor engine in a closed building or without adequate ventilation. The exhaust fumes can be hazardous to your health. (SG-23)

WARNING!



Do not exceed the rated PTO speed for the Implement. Excessive PTO speeds can cause Implement driveline or blade failures resulting in serious injury or death. (SG-26)

DANGER!



Operate the Tractor and/or Implement controls only while properly seated in the Tractor seat with the seat belt securely fastened around you. Inadvertent movement of the Tractor or Implement may cause serious injury or death. (SG-29)

WARNING!



In case of mechanical difficulty during operation, place the transmission in the park position, set the parking brake, shut down all power, including the PTO and the engine and remove the key. Wait until all rotating motion has stop before dismounting. (SG-39)

WARNING!



Never leave the Implement and Power Unit unattended while the Implement is in the raised position. Accidental operation of a lifting lever or a hydraulic failure may cause the mower to suddenly fall causing serious injury or possible death to anyone who might inadvertently be under the Implement. Lower the implement carefully to the ground. Do not put hands or feet under lifted components. (SPU-3)

SAFETY

SAFETY

WARNING!



Only operate the snow blower in conditions where you have clear visibility in daylight or with adequate artificial lighting. Never snow blow in darkness or in conditions where you cannot clearly see at least 100 yards in front and to the sides of the Tractor and Snow Blower. Make sure that you can clearly see and identify passersby, steep slopes, ditches, drop-offs, overhead obstructions, power lines, debris and foreign objects. If you are unable to clearly see these types of items, discontinue snow blowing. (SSB-1)

WARNING!



Extreme care should be taken when operating near loose objects such as gravel, rocks, wire and other debris. Foreign objects should be removed from the site to prevent machine damage and/or bodily injury or even death. Any object that cannot be removed must be clearly marked and carefully avoided by the operator. Stop snow blowing immediately if the auger or fan strikes a foreign object. Repair all damage before resuming snow blowing. (SSB-2)



WARNING!



Many varied objects, such as wire, cable, rope, or chains can become entangled in the operating parts of the Snow Blower. These items could then swing outside the housing at high speeds. Such a situation is extremely hazardous and could result in serious injury or even death. Inspect the work area for such objects before snow blowing. Remove any like object from the site. Never allow the auger to contact such items. (SSB-3)

WARNING!



Blow snow at the speed that you can safely operate and control the Tractor and Snow Blower. Safe speed depends on terrain and snow conditions. Normal ground speed range is from 0 to 5 mph. Use slow speeds when operating on or near steep slopes, ditches, drop-offs, overhead obstructions, power lines, or when debris and foreign objects are to be avoided. (SSB-4)

DANGER!



Snow Blowers are capable under adverse conditions of throwing objects for great distances (200 feet or more). Do not allow the snow stream to fall on passersby. Ice, debris and heavy snow thrown from the snow blower can cause serious injury or death. (SSB-7)



STOP SNOW BLOWING IF PASSERSBY ARE WITHIN 200 FEET.

WARNING!



Do Not blow snow with two machines in the same area except with cab tractors with the windows closed. (SSB-10)

DANGER!



There are obvious and hidden potential hazards in the operation of this Snow Blower. REMEMBER! This machine is often operated in deep snow where vision is reduced. The fan blades of this Snow Blower can throw objects for great distances. Serious injury or even death may occur unless care is taken to insure the safety of the operator, bystanders, or passersby in the area. Do not operate this machine with anyone in the immediate area. Stop Snow Blowing if anyone is within 200 feet of Snow Blower. (SSB-11)

SAFETY

WARNING!



Do not operate Snow Blower if excessive vibration exists. Shut down PTO and the Tractor engine. Inspect the Snow Blower to determine the source of the vibration. If blades are missing or damaged replace them immediately. Do not operate the Snow Blower until the blades have been replaced and the Blower operates smoothly. Operating the Snow Blower with excessive vibration can result in component failure and broken objects to be thrown outward at very high velocities. To reduce the possibility of property damage, serious injury, or even death, never allow the Snow Blower to be operated with blades missing. (SSB-12)

DANGER!



The rotating parts of this machine have been designed and tested for rugged use. However, the blades and rotating members could fail upon impact with heavy, solid objects such as metal guard rails and concrete structures. Such impact could cause the broken objects to be thrown outward at very high velocities. To reduce the possibility of property damage, serious injury, or even death, never allow the rotating blades to contact such obstacles. (SSB-13)

DANGER!



Always keep a careful lookout and use extreme care when working around utility lines. Never allow the Snow Blower within 10 feet of any Utility power or gas line. Heavy snow or ice storms can cause utility lines to sag or drop to the ground. Do not operate this equipment where power lines are on the ground. When working close to Utility lines consult your electric or gas company for a safe code of operation. (SSB-15)

WARNING!



Before dismounting to clear a clogged machine, place the transmission in the park position, set the parking brake, shut down all power, including the PTO and the engine and remove the key. Wait until all rotating motion has stop before dismounting. (SSB-16)

WARNING!



Snow can cover and hide solid objects such as guard rails, curbs, concrete structures, large rocks, utility boxes, fire hydrants, etc. DO NOT allow the rotating parts of the Snow Blower to contact such items. Inspect the area before operating the Snow Blower. Mark all solid items clearly with a pole and flag. To reduce the possibility of property damage, serious injury, or even death, never allow the rotating blades to contact such obstacles. (SSB-20)

WARNING!



The Snow Blower can block the operators vision directly in front of the Snow Blower. Inspect the area before operating the Snow Blower and make sure that there are no obstacles, passersby, or coworkers in the path of the Snow Blower. (SSB-22)

SAFETY

SAFETY

Transporting Safety Instructions and Practices

WARNING!



Be particularly careful when transporting the Implement with the Tractor. Turn curves or go up hills only at a low speed and using a gradual steering angle. Rear mounted implements move the center of gravity to the rear and remove weight from the front wheels. Make certain, by adding front ballast, that at least 20% of the tractor's weight is on the front wheels to prevent rearing up, loss of steering control or Tractor tip-over. Slow down on rough or uneven surfaces to prevent loss of steering control which could result in property damage or possible injury. Do not transport unless 3-Point lift lever is fully raised and in the latched transport position. Dropping implement in transport can cause serious damage to the tractor and/or Implement and possibly cause the operator or others to be injured or killed. (S3PT-2)

WARNING!



Allow sufficient clearance for the Implement to swing outward while turning. Implements carried behind the Tractor will swing outside the tire path when making turns. Contacting a solid object while turning will cause equipment damage and possible injury. (S3PT-20)

WARNING!



Make certain that the "Slow Moving Vehicle" (SMV) sign is installed in such a way as to be clearly visible and legible. When transporting the Equipment use the Tractor flashing warning lights and follow all local traffic regulations. (SG-6)

WARNING!



Transport only at safe speeds. Serious accidents and injuries can result from operating this equipment at unsafe speeds. Understand the Tractor and Implement and how it handles before transporting on streets and highways. Make sure the Tractor steering and brakes are in good condition and operate properly.

Before transporting the Tractor and Implement, determine the safe transport speeds for you and the equipment. Make sure you abide by the following rules:

1. Test the tractor at a slow speed and increase the speed slowly. Apply the Brakes smoothly to determine the stopping characteristics of the Tractor and Implement. As you increase the speed of the Tractor the stopping distance increases. Determine the maximum safe transport speed for you and this Equipment.
2. Test the equipment at a slow speed in turns. Increase the speed through the turn only after you determine that it is safe to operate at a higher speed. Use extreme care and reduce your speed when turning sharply to prevent the tractor and implement from turning over. Determine the maximum safe turning speed for you and this equipment before operating on roads or uneven ground.
3. Only transport the Tractor and Implement at the speeds that you have determined are safe and which allow you to properly control the equipment.

Be aware of the operating conditions. Do not operate the Tractor with weak or faulty brakes. When operating down a hill or on wet or rain slick roads, the braking distance increases: use extreme care and reduce your speed. When operating in traffic always use the Tractor's flashing warning lights and reduce your speed. Be aware of traffic around you and watch out for the other guy. (SG-19)

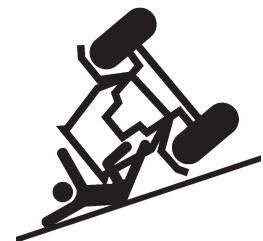

SAFETY

WARNING!



Before transporting the Snow Blower, position the snow discharge shoot in the center position to reduce the possibility of blocking the operators vision. (SSB-21)

WARNING!



Your driving vision may be reduced or impaired by the tractor, cab, or implement. Before driving on public roadways identify any limited vision areas, and make adjustments to your operating position, mirrors, and the implement transport position so that you can clearly see the area where you will be traveling, and any traffic that may approach you. Failure to maintain adequate vision of the public roadway and traffic can result in serious injury or even death. (STI-10)

Maintenance and Service Safety Instructions and Practices

DANGER!



Make sure the PTO shield, integral driveline shields, and input shields are installed when using PTO-driven equipment. Always replace any shield if it is damaged or missing. (S3PT-8)



WARNING!



Relieve hydraulic pressure prior to doing any maintenance or repair work on the Implement. Place the Implement on the ground or securely blocked up, disengage the PTO, and turn off the tractor engine. Push and pull the Remote Cylinder lever in and out several times prior to starting any maintenance or repair work. (S3PT-9)



WARNING!



Always maintain the safety decals in good readable condition. If the decals are missing, damaged, or unreadable, obtain and install replacement decals immediately. (SG-5)

WARNING!



Do not modify or alter this Implement. Do not permit anyone to modify or alter this Implement, any of its components or any Implement function. (SG-8)

DANGER!



Never work under the Implement, the framework, or any lifted component unless the Implement is securely supported or blocked up to prevent sudden or inadvertent falling which could cause serious injury or even death. (SG-14)



WARNING!



Never attempt to lubricate, adjust, or remove material from the Implement while it is in motion or while tractor engine is running. Make sure the tractor engine is off before working on the Implement. (SG-20)

SAFETY

SAFETY

WARNING!



Periodically inspect all moving parts for wear and replace when necessary with authorized service parts. Look for loose fasteners, worn or broken parts, and leaky or loose fittings. Make sure all pins have cotter pins and washers. Serious injury may occur from not maintaining this machine in good working order. (SG-21)



WARNING!



Perform service, repairs and lubrication according to the maintenance section. Ensure the unit is properly lubricated as specified in the lubrication schedule and all bolts and nuts are properly torqued. Failure to properly service, repair and maintain this Implement in good operating condition could cause component failure and possible serious injury or even death. (SG-35)

DANGER!



Replace bent or broken blade with new blades. NEVER ATTEMPT TO STRAIGHTEN OR WELD ON BLADES SINCE THIS WILL LIKELY CRACK OR OTHERWISE DAMAGE THE BLADE WITH SUBSEQUENT FAILURE AND POSSIBLE SERIOUS INJURY FROM THROWN BLADES. (SGM-10)

DANGER!



Always disconnect the main PTO Driveline from the Tractor before performing service on the Snow Blower. Never work on the Snow Blower with the Tractor PTO driveline connected and running. The Fan, Auger or Drivelines could turn without warning and cause immediate entanglement, injury or death. (SSB-8)

WARNING!



All Safety Shields, Guards and Safety devices including (but not limited to) - the Chain Shield, Cross Shaft Shield, Gearbox Shields, and PTO integral shields must be used and maintained in good working condition. All safety devices should be inspected carefully at least daily for missing or broken components. Missing, broken, or worn items must be replaced at once to reduce the possibility of injury or death from entanglement. (SSB-9)

WARNING!



DO NOT weld or repair rotating Blower components. Welds and other repairs may cause severe vibration and/or component failure resulting in parts being thrown from the blower causing serious bodily injury. See your Authorized Dealer for proper repairs. (SSB-14)

WARNING!



Ensure the remote starting system is inoperative before servicing or cleaning the machine. Inadvertent engine start up could result in entanglement or runover causing serious injuries or death. (SSB-17)

WARNING!



Use only OEM specified shear pins as replacements pins. The use of incorrect shear pins can cause failures in the Snow Blower rotating components resulting in property damage and/or serious bodily injuries. (SSB-19)

SAFETY

DANGER!



All Safety Shields, Guards and other Protective Safety devices should be used and maintained in good working condition. All safety devices should be inspected carefully at least daily for missing or broken components. **NEVER REMOVE PROTECTIVE SHIELDS AND GUARDS! NEVER MODIFY OR CUT PROTECTIVE SHIELDS OR GUARDS!** When shields or guards are removed to access areas for maintenance, they must be replaced and be in good condition before operating. Missing, broken, or worn shields, guards, and other protective devices must be replaced at once and prior to operation to reduce the possibility of injury or death from thrown objects, entanglement, or contact. (SWS-2)

PARTS INFORMATION

Alamo Industrial mowers use balanced and matched system components for blade carriers, blades, cuttershafts, knives, knife hangers, rollers, drivetrain components, and bearings. These parts are made and tested to Alamo Industrial specifications. Non-genuine "will fit" parts do not consistently meet these specifications. The use of "will fit" parts may reduce mower performance, void mower warranties, and present a safety hazard. Use genuine Alamo Industrial mower parts for economy and safety. (SPAM-1)

SEE YOUR ALAMO DEALER

Concluding Safety Instructions and Practices

In addition to the design and configuration of this Implement, including Safety Signs and Safety Equipment, hazard control and accident prevention are dependent upon the awareness, concern, prudence, and proper training of personnel involved in the operation, transport, maintenance, and storage of the machine. Refer also to Safety Messages and operation instruction in each of the appropriate sections of the Tractor and Equipment Manuals. Pay close attention to the Safety Signs affixed to the Tractor and Equipment. (SG-18)

SAFETY

SAFETY

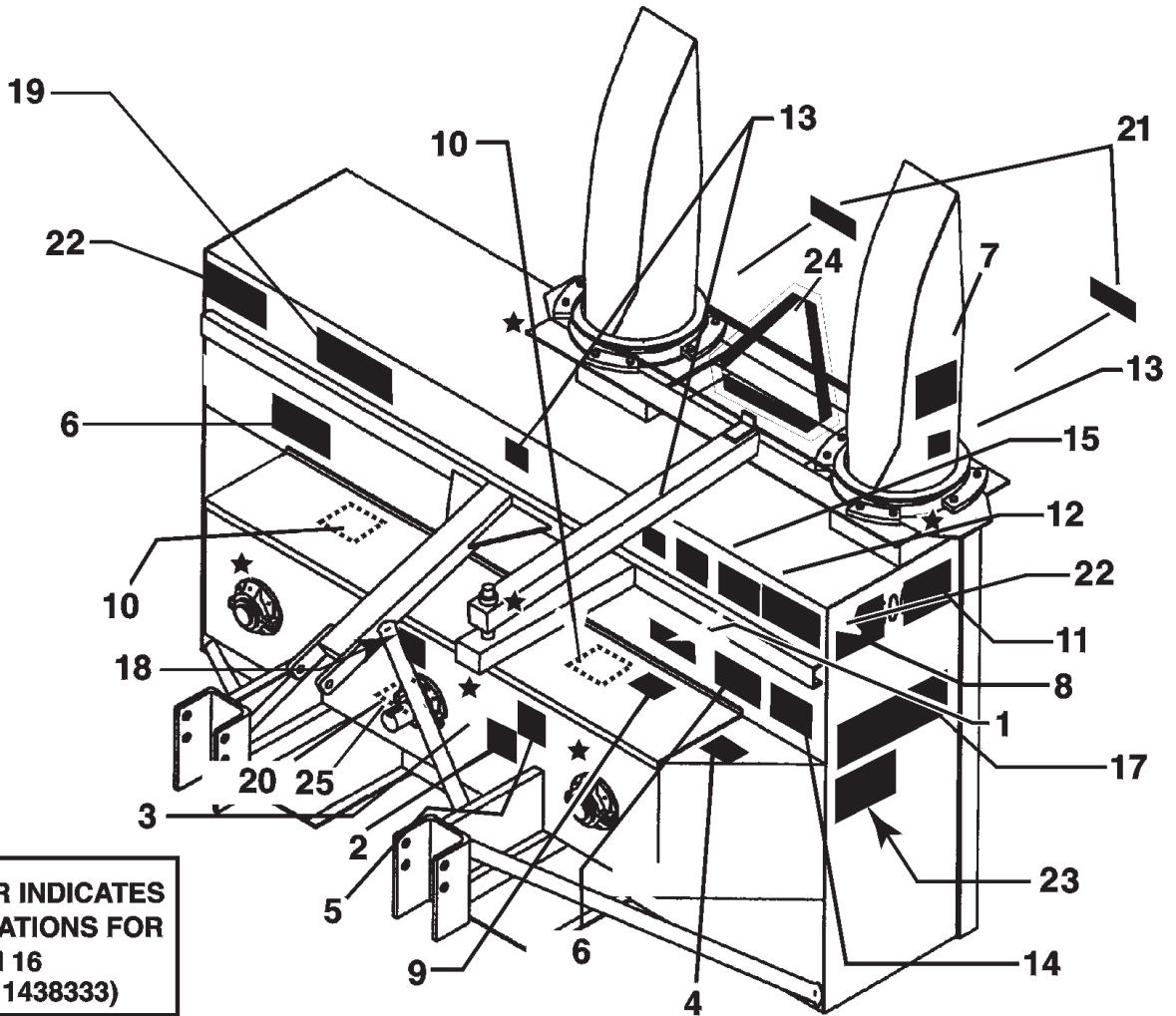
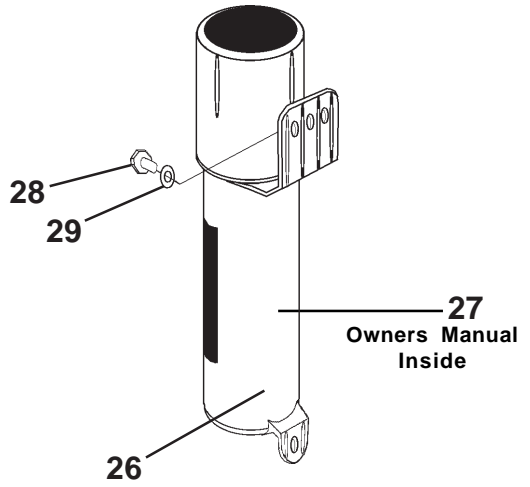

★ STAR INDICATES
LOCATIONS FOR
ITEM 16
(PN: 1438333)

SAFETY

SAFETY

ITEM	PART NO.	QTY.	DESCRIPTION
1	00725746	1	Decal Peligro
2	00756494	1	Decal Danger- Driveline Installation
3	00760657	1	Decal Genuine Rhino Parts
4	00763977	1	Decal Notice To Owner
5	00763723	1	Decal Peligro-Driveline
6	00784039	2	Decal Warning Multi-Hazard
7	00784040	2	Decal Danger-From Rotating Snowblower Fan
8	00784041	2	Decal Warning Thrown Objects
9	00784043	1	Decal Danger Moving Parts
10	00784044	2	Decal Danger Guard Missing
11	00784045	2	Decal Danger Stay Back From Snowblower Intake
12	00784061	1	Decal Warning Do Not Let Snowblower Contact Electrical Wires
13	02962764	4	Decal Pinch Points
14	02962765	1	Decal Danger Multi Hazard Pinch Points
15	02965262	1	Decal Warning Hose Burst
16	1438333	6	Decal Grease -10 Hrs
17	001651	2	Decal Alamo Industrial Logo - 2-3/8" x 16-11/16"
18	D114	1	Decal Warning - 1000 RPM
19	00757139	2	Decal Alamo Industrial Logo - 2-7/8" x 20"
20	00756004	2	Decal Shield Missing
21	1458392	2	Decal Red Reflector
22	1458393	2	Decal Yellow Reflector
23	00784637	2	Decal Great White 8650-A
24	03200347	1	SMV
25	00756005	1	Decal Rotating Driveline
26	00776031	1	Canister, Operators Manual
27	5042C	1	Operators Manual
28	00721129	3	TEK Screw
29	00024100	3	Flatwasher

NOTE: Alamo Industrial supplies safety decals on this product to promote safe operation. Damage to the decals may occur while in shipping, use, or reconditioning. Alamo Industrial cares about the safety of its customers, operators, and bystanders, and will replace the safety decals on this product in the field, free of charge (Some shipping and handling charges may apply). Contact your Alamo Industrial dealer to order replacement decals.

SAFETY

SAFETY

Item 1: Peligro- Spanish Translation



P/N 00725746

Item 2: Driveline Installation



P/N 00756494

Item 3: Use Genuine Alamo Industrial Parts

IMPORTANT

For your safety and to guarantee optimum product reliability, always use Genuine ALAMO INDUSTRIAL replacement parts. The use of inferior "will-fit" parts will void Warranty of your ALAMO INDUSTRIAL implement and may cause premature or catastrophic failure which can result in serious injury or death. If you have any questions concerning the repair parts you are using, contact ALAMO INDUSTRIAL, 1502 E. Walnut Seguin, TX 78155 (830) 372-3551.

ALAMO
INDUSTRIAL 02925100

P/N 02925100

Item 4: Notice To Owner

NOTICE TO OWNER

An OPERATOR'S MANUAL (with Repair Parts Listing) and a WARRANTY REGISTRATION CARD were attached to this implement during final inspection at the factory. If they were not attached at the time of purchase, please contact your selling dealer at once.

1. Read and understand Manual before operating the implement.
2. Complete, sign, and mail the Warranty Registration Card in today.

00763977

P/N 00763977

SAFETY

SAFETY

Item 5: Peligro Driveline Instructions In Spanish



P/N 00773723

Item 6: Warning Multi-Hazard (See Inside Front Cover)

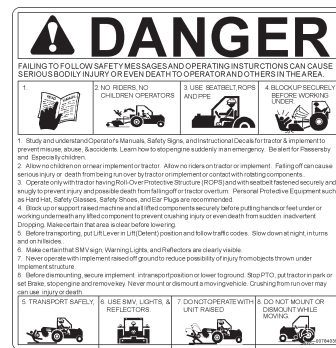

P/N 00784039

Item 7: Danger From Rotating Snowblower Fan



P/N 00784040

Item 8: Warning Thrown Objects



P/N 00784041

SAFETY

SAFETY

Item 9: Danger Moving Parts



P/N 00784043

Item 10: Danger Guard Missing

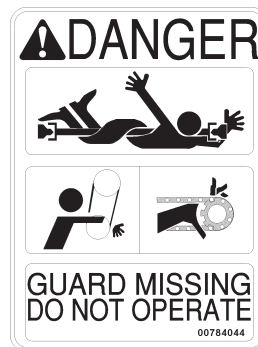

P/N 00784044

Item 11: Stay Back From Snowblower Intake



P/N 00784045

Item 12: Warning Do Not Let Blower Spout Contact Electrical Power Lines

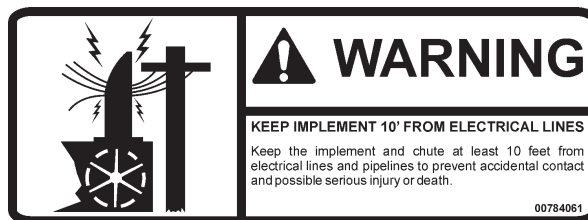

P/N 00784061

SAFETY

SAFETY

Item 13: Danger Pinch Points

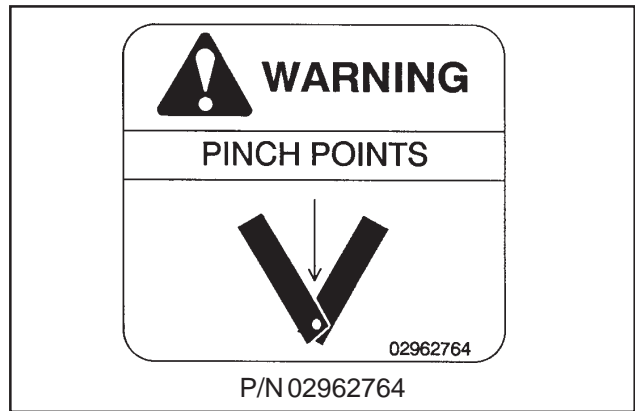

Item 14: Danger Multi-Hazard Pinch Points



Item 15: Warning Hose Burst



Item 16: Apply Grease Every 10 hrs

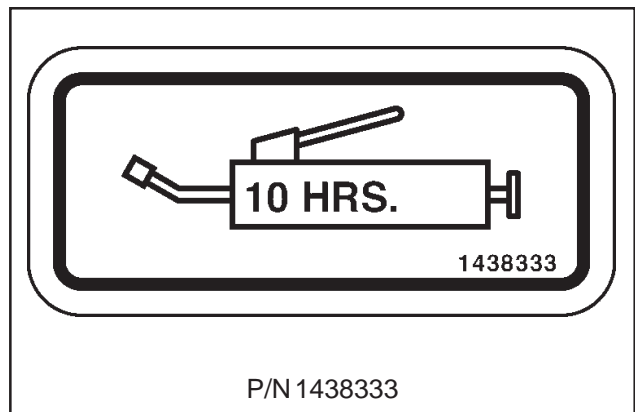

SAFETY

SAFETY

Item 17: Alamo Industrial LOGO



P/N 001651

Item 18: RPM 1000



P/ND114

Item 19: Alamo Industrial LOGO



P/N 00757139

Item 20: Shield Missing



P/N 00756004

SAFETY

SAFETY

Item 21: Red Reflector; Keep reflector clear and visible at all times.

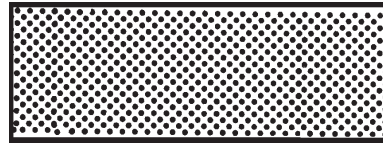

P/N 1458392

Item 22: Yellow Reflector; Keep reflector clear and visible at all times.

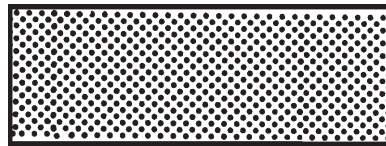

P/N 1458393

Item 23: 8650-A LOGO



P/N 00784637

Item 24: SMV - Keep reflector clear and visible at all times.



P/N 03200347

SAFETY

SAFETY

Item 25: Rotating Driveline



P/N 00756005

SAFETY

FEDERAL LAWS AND REGULATIONS

This section is intended to explain in broad terms the concept and effect of federal laws and regulations concerning employer and employee equipment operators. This sections is not intended as a legal interpretation of the law and should not be considered as such.

Employer-Employee Operator Regulations

U.S. Public Law 91-596 (The Williams-Steiger Occupational and Health Act of 1970) OSHA

This Act Seeks:

"...to assure so far as possible every working man and woman in the nation safe and health working conditions and to preserve our human resources..."

DUTIES

Sec. 5 (a) Each employer-

- (1) shall furnish to each of his employees employment and a place of employment which are free from recognized hazards that are causing or are likely to cause death or serious physical harm to his employees;
- (2) shall comply with occupational safety and health standards promulgated under this Act.
- (b) Each employee shall comply with occupational safety and health standards and all rules, regulations and orders issued pursuant to this Act which are applicable to his own actions and conduct.

OSHA Regulations

OSHA regulations state in part: " At the time of initial assignment and at least annually thereafter, the employer shall instruct every employee in the safe operation and servicing of all equipment with which the employee is, or will be involved."

Employer Responsibilities:

To ensure employee safety during Tractor and Implement operation, it is the employer's responsibility to:

1. Train the employee in the proper and safe operation of the Tractor and Implement.
2. Require that the employee read and fully understand the Tractor and Implement Operator's manual.
3. Permit only qualified and properly trained employees to operate the Tractor and Implement.
4. Maintain the Tractor and Implement in a safe operational condition and maintain all shields and guards on the equipment.
5. Ensure the Tractor is equipped with a functional ROPS and seat belt and require that the employee operator securely fasten the safety belt and operate with the ROPS in the raised position at all times.
6. Forbid the employee operator to carry additional riders on the Tractor or Implement.
7. Provide the required tools to maintain the Tractor and Implement in a good safe working condition and provide the necessary support devices to secure the equipment safely while performing repairs and service.
8. Require that the employee operator stop mowing if bystanders or passerbys come within 100 yards.

Child Labor Under 16 Years of Age

Some regulations specify that no one under the age of 16 may operate power machinery. It is your responsibility to know what these regulations are in your own area or situation. (Refer to U.S. Dept. of Labor, Employment Standard Administration, Wage & Home Division, Child Labor Bulletin #102.)

INTRODUCTION SECTION

INTRODUCTION

INTRODUCTION

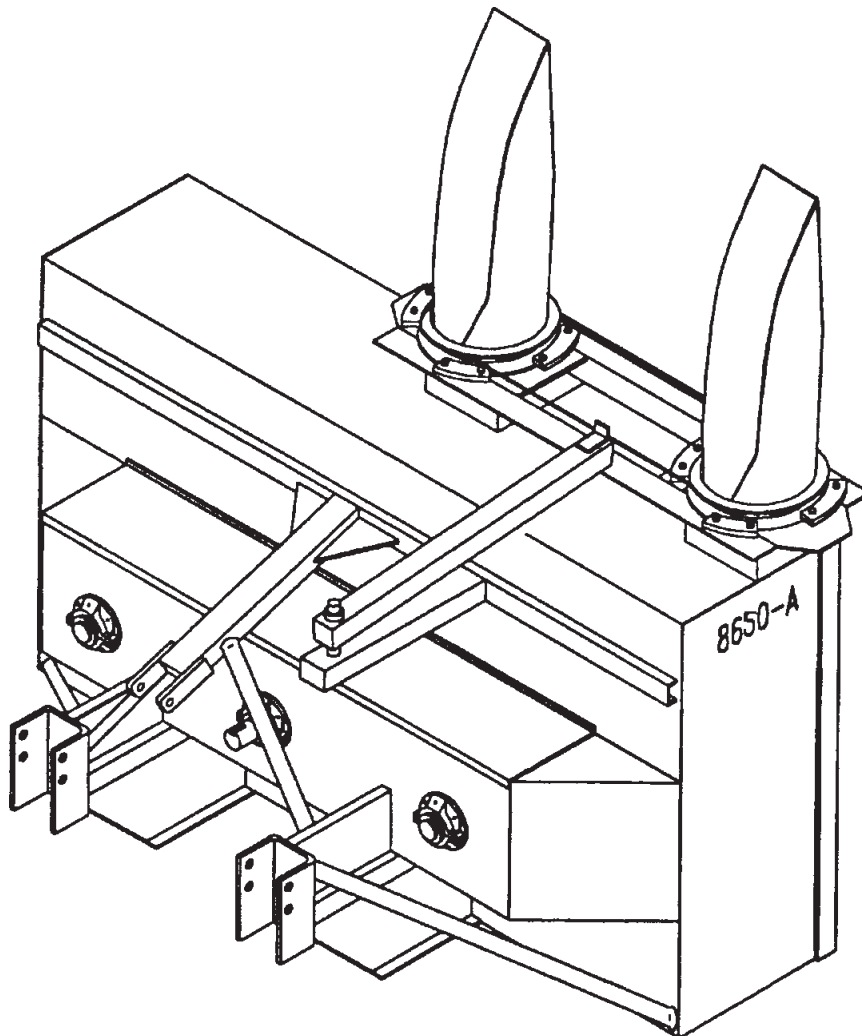

The 8650A Snow Blowers are designed for removing accumulations of snow from driveways, barnyards, roadways and parking lots. Check local regulations before operating on roadways. With proper maintenance as described in this manual, your Snow Blower will provide you with years of dependable service with a minimum of repairs.

It is recommended that all operators of this implement read this manual or be instructed of its contents as to safety, proper operation, and maintenance before beginning operation.

For the purpose of this Alamo Industrial equipment, the following definitions apply.

Left hand side: Side which is to the left when the operator is facing in the normal forward direction of the tractor.

Right hand side: Side which is to the right when the operator is facing in the normal forward direction of the tractor.

INTRODUCTION

ATTENTION OWNER/OPERATOR

BEFORE OPERATING THIS MACHINE:

1. Carefully read the Operator's Manual, completely understand the Safety Messages and instructions, and know how to operate the equipment correctly.

2. Fill out the Warranty Card in full. Be sure to answer all questions, including the Serial Number of the Implement. Mail within 30 days of delivery date of this implement.

NOTE: Warranties are honored only if completed "Owner Registration and Warranty" forms are received by Alamo Industrial within thirty days of delivery of the Implement.

3. Record the Implement Model and Serial Numbers on the Warranty page at the front of the Operator's Manual. Keep this as part of the permanent maintenance file for the Implement.

IMPORTANT

For your safety and to guarantee optimum product reliability, always use Genuine ALAMO INDUSTRIAL replacement parts. The use of inferior "will-fit" parts will void Warranty of your ALAMO INDUSTRIAL implement and may cause premature or catastrophic failure which can result in serious injury or death. If you have any questions concerning the repair parts you are using, contact ALAMO INDUSTRIAL, 1502 E. Walnut Seguin, TX 78155 (830) 372-3551.

///ALAMO
INDUSTRIAL

02925100

**ASSEMBLY
SECTION**

ASSEMBLY

ASSEMBLY

Hydraulic Chute Rotation Cylinder

1. A standard 3 x 8 inch stroke hydraulic cylinder, 20-1/4 closed pin centers, must be fitted to the chute rotation mechanism. **DO NOT** install any longer stroke, or non-standard hydraulic cylinders as damage to the chute rotation mechanism will result.



2. A hydraulic restrictor is required to limit hydraulic flow.

3. Attach PTO Shaft to snow blower. Install key in shaft, slide yoke over shaft and fasten with setscrew (A). Tighten setscrew (B) at 90° to keyway and lock down with jam nut (C).

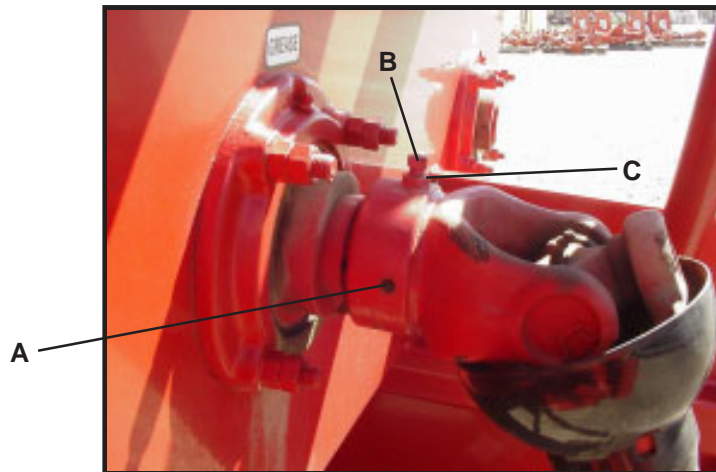

NOTE: Lubricate telescoping members of driveline.

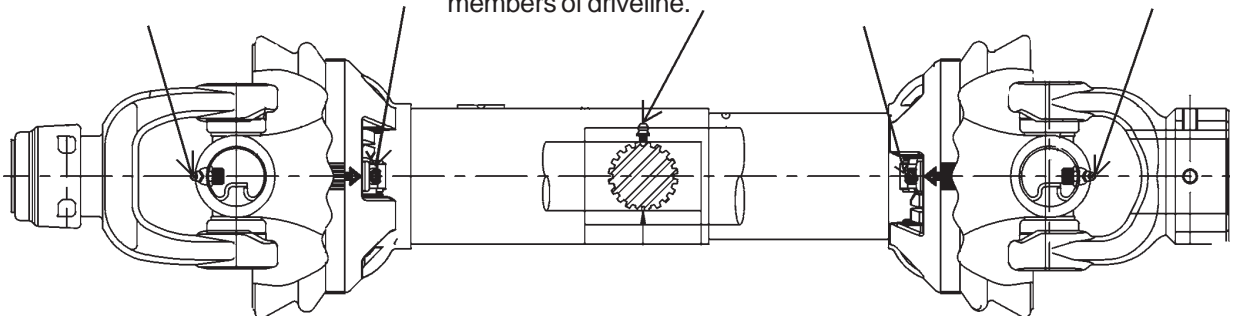

ASSEMBLY

4. The Snowblower is easily adaptable to all standard Category 2 and 3 hitch arrangements. These illustrations will detail which pins and bushings you will need for your tractor hitch.

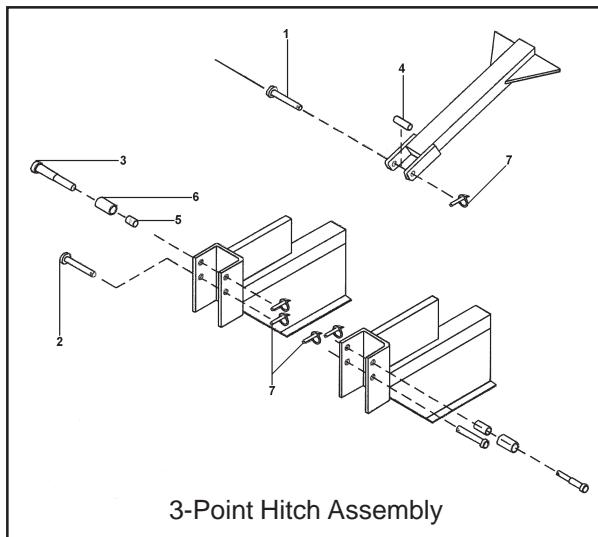
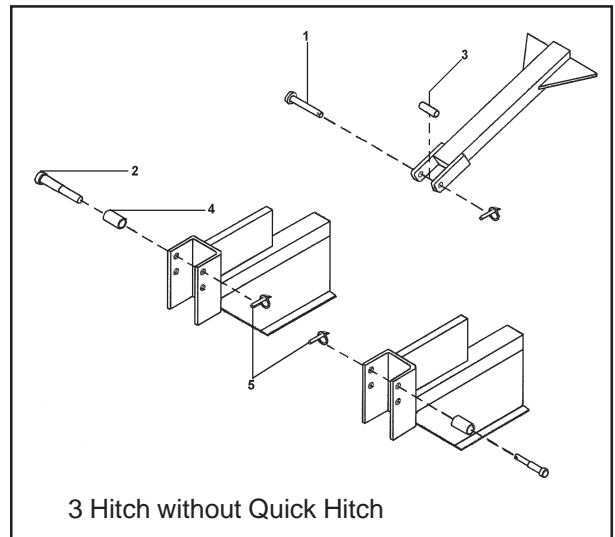
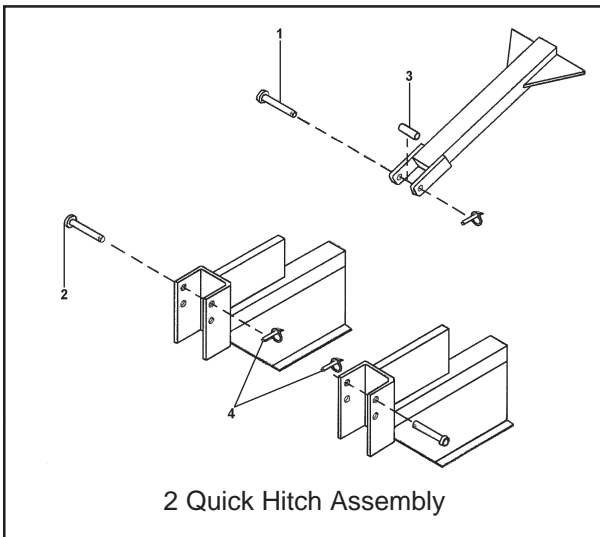
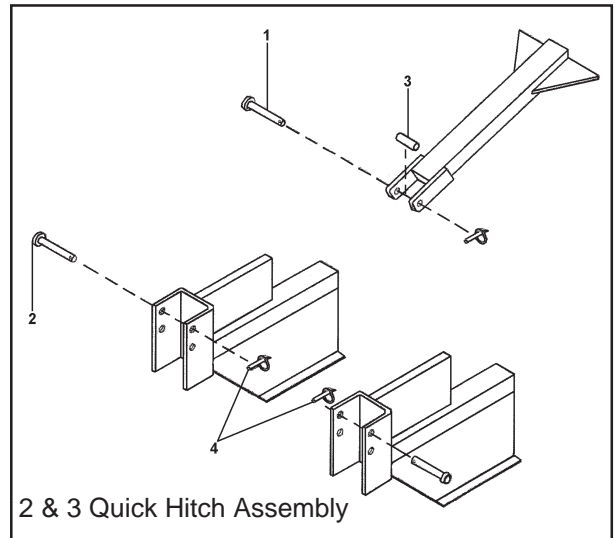
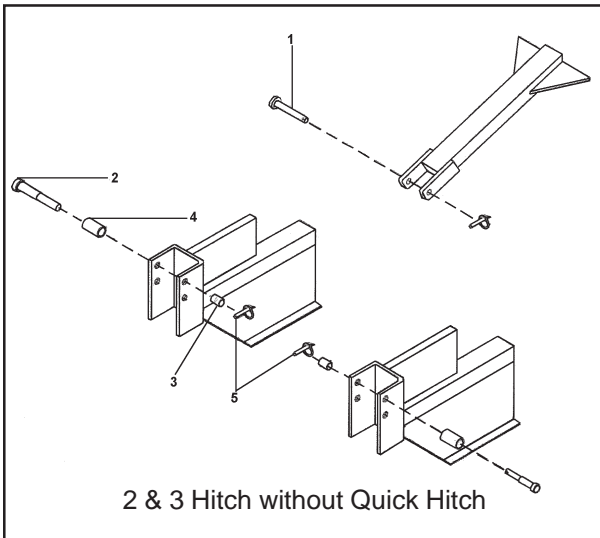

ASSEMBLY

ASSEMBLY

5. Attach the snow blower to the tractor and level the snow blower.

WARNING!



IMPORTANT: Precautions must be taken when mounting the snow blower to your tractor to ensure that there is adequate clearance to allow the universal joint assembly to operate within its designed slip range. Failure to properly install the universal joint may cause the universal joint to separate during operation possibly resulting in personal injury or damage to equipment

6. Carefully raise and lower the snow blower.

7. Attach the universal joint assembly to the tractor. Slide slidelock collar back and slide on tractor PTO shaft until locking collar engages.

IMPORTANT: Pull and push on the quick disconnect yokes several times to ensure that the yokes are properly connected to their respective shafts.

8. Check for correct overlap of driveline and ensure driveline is not bottoming out. Raise and lower machine to make sure. Main drive overlap is 5 inches.

9. Check that the snow blower is level side to side. Adjust tractor lift link if necessary.

10. Check that the tractor three point hitch check chains are snug but not overly tight. Side sway should be kept to a minimum.

OPERATION SECTION

OPERATION

ALAMO INDUSTRIAL SNOW BLOWER 8650A OPERATION INSTRUCTIONS

ALAMO INDUSTRIAL SNOW BLOWER 8650A is manufactured with quality material by skilled workers. This snow blower is designed for removing accumulations of snow from driveways, barnyards, roadways, and parking lots. The implement is equipped with enough protective gear to maintain the objects being thrown from SNOW BLOWER 8650A to prevent injury to bystanders and others, however, no shielding is 100% accurate. All shields and guards must be maintained in good operational condition.

It is the operator's responsibility to be knowledgeable of all potential operating hazards and to take every reasonable precaution to ensure oneself, others, animals, and property are not injured or damaged by the SNOW BLOWER 8650A, tractor, or a thrown object. Do not operate the implement if passersby, pets, livestock, or property are within 200 feet of the unit.

This section of the Operator's Manual is designed to familiarize, instruct, and educate safe and proper implement use to the operator. Pictures contained in this section are intended to be used as a visual aid to assist in explaining the operation of a SNOW BLOWER 8650A and are not necessarily of a SNOW BLOWER 8650A. Some pictures may show shields removed for picture clarity. NEVER OPERATE these implements without all shields in place and in good operational condition. The operator must be familiar with the SNOW BLOWER 8650A and tractor operation and all associated safety practices before operating the SNOW BLOWER 8650A and tractor. Proper operation of the SNOW BLOWER 8650A, as detailed in this manual, will help ensure years of safe and satisfactory use.

IMPORTANT: To avoid implement damage, retorque all bolts after the first 10 hours of operation.

(1) OPERATOR REQUIREMENTS.....	4-4
(2) TRACTOR REQUIREMENTS.....	4-5
(2.1) ROPS and Seatbelt.....	4-5
(2.2) Tractor Safety Devices.....	4-6
(2.3) Tractor Horsepower.....	4-6
(2.4) 3-Point Hitch.....	4-6
(2.5) Tractor Hydraulics.....	4-6
(2.6) Front End Weight.....	4-6
(2.7) Power Take Off (PTO).....	4-7
(2.8) Tire Spacing.....	4-7
(3) GETTING ON AND OFF THE TRACTOR.....	4-8
(3.1) Boarding the Tractor.....	4-8
(3.2) Dismounting the Tractor.....	4-8
(4) STARTING THE TRACTOR.....	4-9
(5) CONNECTING THE SNOW BLOWER TO THE TRACTOR	4-10
(5.1) Connecting the Snow Blower to the Tractor	4-10
(6) DRIVELINE ATTACHMENT.....	4-11
(6.2) Connecting Snow Blower Hydraulic lines to the tractor.....	4-12
(7) PRE-OPERATION INSPECTION AND SERVICE.....	4-12
(7.1) Tractor Pre-Operation Inspection/Service.....	4-13
(7.2) Snow Blower Pre-Operation Inspection/Service.....	4-13

OPERATION

(8) DRIVING THE TRACTOR AND SNOW BLOWER.....	4-16
(8.1) Starting the Tractor.....	4-17
(8.2) Brake and Differential Lock Setting.....	4-17
(8.3) Driving the Tractor and Snow Blower.....	4-18
(8.4) Crossing Ditches and Steep Inclines.....	4-19
(9) OPERATING THE TRACTOR AND SNOW BLOWER.....	4-20
(9.1) Foreign Debris Hazards.....	4-20
(9.2) Engaging the Power Take Off (PTO).....	4-21
(9.3) PTO RPM and Ground Speed.....	4-21
(10) OPERATING THE SNOW BLOWER	4-22
(10.1) Shutting Down the Implement.....	4-24
(11) DISCONNECTING THE SNOW BLOWER FROM THE TRACTOR.....	4-25
(12) SNOW BLOWER STORAGE.....	4-26
(13) TRANSPORTING THE TRACTOR AND SNOW BLOWER.....	4-27
(13.1) Transporting on Public Roadways.....	4-28
(14) Hauling the Tractor And Snow Blower.....	4-31
(15) TROUBLE SHOOTING GUIDE.....	4-32

READ AND UNDERSTAND THE ENTIRE OPERATING INSTRUCTIONS AND SAFETY SECTION OF THIS MANUAL AND THE TRACTOR MANUAL BEFORE ATTEMPTING TO USE THE TRACTOR AND IMPLEMENT.

If you do not understand any of the instructions, contact your nearest authorized dealer for a full explanation. Pay close attention to all safety signs and safety messages contained in this manual and those affixed to the Implement and tractor.

DANGER!



READ, UNDERSTAND, and FOLLOW the following Safety Messages. Serious injury or death may occur unless care is taken to follow the warnings and instructions stated in the Safety Messages. Always use good common sense to avoid hazards. (SG-2)

SAFETY INSTRUCTIONS



PELIGRO!



Si no lee Ingles, pida ayuda a alguien que si lo lea para que le traduzca las medias de seguridad. (SG-3)

!LEA EL INSTRUCTIVO!



OPERATION

OPERATION

1. OPERATOR REQUIREMENTS

Safe operation of the snow blower is the responsibility of a qualified operator. A qualified operator has read and understands both the snow blower and tractor Operator Manuals and is experienced in tractor and snow blower operations and all associated safety practices. In addition to the safety messages contained in this manual, safety message decals are affixed to the snow blower and tractor. If any part of the operation and safe use of the snow blower and tractor is not completely understood, consult an authorized dealer for a full explanation.

Safe operation requires that the operator wear approved Personal Protective Equipment (PPE) for the job conditions while connecting, operating, servicing and repairing the snow blower and tractor. PPE is designed to provide operator protection from bodily injury and includes the following:

Personal Protective Equipment (PPE)

- Protective eye glasses, goggles, or face shield
- Hard hat
- Steel toed safety footwear
- Gloves
- Hearing protection
- Close fitting clothing
- Respirator or filter mask



OPERATION

DANGER!



NEVER use drugs or alcohol immediately before or while operating the Tractor and Implement. Drugs and alcohol will affect an operator's alertness and coordination and therefore affect the operator's ability to operate the Equipment safely. Before operating the Tractor or Implement, an operator on prescription or over-the-counter medication must consult a medical professional regarding any side effects of the medication that would hinder their ability to operate the Equipment safely. **NEVER** knowingly allow anyone to operate this Equipment when their alertness or coordination is impaired. Serious injury or death to the operator or others could result if the operator is under the influence of drugs or alcohol. (SG-27)



OPERATION

2. TRACTOR REQUIREMENTS

The tractor used to operate the snow blower must have the power capacity to lift, pull, and operate the Power Take Off (PTO) at the snow blower's rated speed while traveling at a ground speed between 2 and 5 MPH. Operating the snow blower with a tractor that does not meet the following requirements may cause tractor or snow blower damage and be a potential danger to the operator and passersby.

Tractor Requirements and Capabilities

- ASAE approved Roll-Over Protective Structure (ROPS) or ROPS cab and seat belt.
- Tractor Safety Devices..... Slow Moving Vehicle (SMV) emblem, lighting, PTO master shield
- Tractor Horsepower - Recommended..... SNOW BLOWER 8650A 120-275 hp
- Front End Weights..... As needed to maintain 20% weight on front axle
- Power Take Off..... Operating speed and shaft size should be 1000 RPM
- Tire Spacing..... Set tires minimum width of 60" inside to inside of tires.

2.1 ROPS and Seat Belt

A Roll-Over-Protective-Structure (ROPS) and seat belt are essential to protect the operator from falling off the tractor, especially during a roll over where the driver could be crushed and killed. The ROPS and seat belt must be used in conjunction with one another. Only operate the tractor with the ROPS in the raised position and seat belt fastened. Tractor models not equipped with a ROPS and seat belt should have these life saving features installed by an authorized tractor dealer.

WARNING!



Operate this Equipment only with a Tractor equipped with an approved roll-over-protective system (ROPS). Always wear seat belts. Serious injury or even death could result from falling off the Tractor--particularly during a turnover when the operator could be pinned under the ROPS. (SG-7)



2.2 Tractor Safety Devices

If transporting or operating the tractor and snow blower near a public roadway, the tractor must be equipped with proper warning lighting and a Slow Moving Vehicle (SMV) emblem which are clearly visible from the rear of the unit. Lights and a SMV emblem must be equipped directly on implements if the visibility of the tractor warning signals are obscured.

Maintain all manufacturer equipped safety shields and guards. Always replace shields and guards that were removed for access to connect, service, or repair the tractor or implement. Never operate the tractor PTO with the PTO master shield missing or in the raised position.

OPERATION

2.3 Tractor Horsepower

The horsepower required to operate the implement depends on several operating factors including terrain condition, operator experience, condition of the implement and tractor, and other factors. The recommended tractor HP for the SNOW BLOWER 8650A is 120-275hp (89-205kw). Operating the implement with a larger tractor will greatly increase the risk of damaging the implement.

2.4 3-Point Hitch

The tractor 3-point hitch must be rated to lift the 8650A Snow Blower.

The Snow Blower can attach to tractor's with a 3-pt hitch frame. The 8650A Snow Blower is easily adaptable to all standard Category 2 and 3 hitch arrangements. Refer to the parts manual of the Snow Blower to get more details of which pins and bushings you will need for your tractor. Refer to the tractor operator's manual for the category of the tractor used. If the hitch does not conform to ASAE dimensions, the implement may not fit or raise properly. Consult an authorized dealer for possible modification procedures to mount nonconforming hitches. Use the correct hitch pins for the hitch being used.

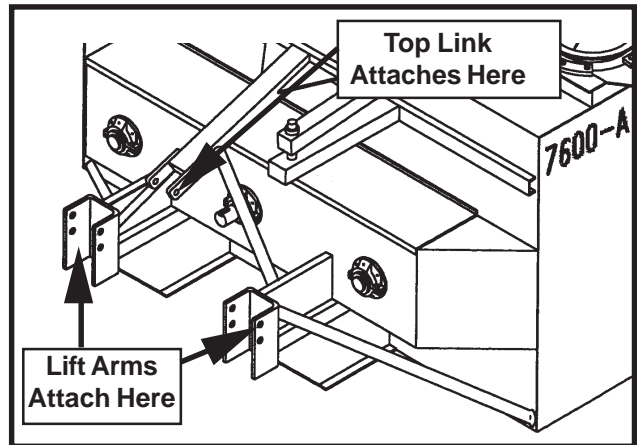

OPERATION

DANGER!



Never crawl under a raised Implement supported solely by the Tractor 3-Point hitch. Release of the control lever or mechanical failure will result in the Implement falling and possible injury or death. Always securely block up the Implement before crawling underneath to perform repairs and service. (S3PT-19)

2.5 Tractor Hydraulics

To be able to operate the hydraulic chute cylinder and the lift cylinders the tractor requires 13 gpm or 15 gpm dual remote outlet. The hydraulic chute cylinder allows you to rotate your chute to blow snow at different angles. Be particularly careful when rotating the chute at different angles, be sure there are no bystanders or animals within 200 ft. in the direction you are blowing snow.

2.6 Front End Weight

A minimum of 20% total tractor weight must be maintained on the tractor front end at all times. Front end weight is critical to maintain steering control and to prevent the tractor from rearing up while driving. If the front end is too light, add weight until a minimum of 20% total weight is reached on the front tires. Front weights and weight carriers can be purchased through an authorized tractor dealership. Add weight as required.

OPERATION

2.7 Power Take Off (PTO)

The implement is designed to operate at a PTO speed of 1000 RPM. Most tractors operate at either 540, or a combination of 540 and 1000 RPM PTO speeds. The operating speed of the implement and tractor can be determined by the number of splines on the driveline yoke and PTO output shaft. Those operating at 540 RPM will have a 1-3/8" diameter 6-spline shaft and those operating at 1000 RPM will have a 1-3/8" 21-spline shaft or a 1-3/4" 20 spline shaft. Refer to the tractor owner's manual for instructions to change PTO speeds on models that operate at more than one speed.

If operating an older model tractor where the tractor's transmission and PTO utilize one master clutch, an over-running clutch must be used between the PTO output shaft and the driveline of the implement. An authorized tractor dealer can provide the over-running clutch and its installation if needed.

WARNING!



DO NOT use a PTO adapter to attach a non-matching Implement driveline to a Tractor PTO. Use of an adapter can double the operating speed of the implement resulting in excessive vibration and thrown objects. Adapter use will also change the working length of the driveline exposing unshielded driveline areas. Serious bodily injury and/or equipment failure can result from using a PTO adapter. Consult an authorized dealer for assistance if the Implement driveline does not match the Tractor PTO. (S3PT-14)

WARNING!



Never operate the Tractor and unit if the Implement input driveline is directly connected to the Tractor transmission. Tractor braking distances can be substantially increased by the momentum of the rotating implement driving the Tractor transmission even though the Tractor clutch has been disengaged. Install an over running clutch between the Tractor PTO and the Implement driveline to prevent this potentially dangerous situation.

(S3PT-16)

2.8 Tire Spacing

Tractor tires should be set a minimum of 60" apart measured from inside of tire to inside of tire. Refer to the tractor Operator's Manual or consult an authorized dealer for instructions to change tractor tire spacing.



OPERATION

3. GETTING ON AND OFF THE TRACTOR

Before getting onto the tractor, the operator must read and completely understand the implement and tractor operator manuals. If any part of either manual is not completely understood, consult an authorized dealer for a complete explanation.

WARNING!



Do not mount the Tractor while the tractor is moving. Mount the Tractor only when the Tractor and all moving parts are completely stopped. (SG-12)



3.1 Boarding the Tractor

Use both hands and equipped handrails and steps for support when getting on the tractor. Never use tractor control levers for support when mounting the tractor. Always seat yourself in the operator's seat and fasten the seatbelt. Only operate the tractor and implement with the ROPS in the raised position.

Never allow passengers to ride on the tractor or implement. Riders can easily fall off and be seriously injured or killed from being ran over by both the tractor and implement. It is the operator's responsibility to forbid riders.

DANGER!



Never allow children or other persons to ride on the Tractor or Implement. Falling off can result in serious injury or death. (SG-10)



DANGER!



Never allow children to operate or ride on the Tractor or Implement. (SG-11)



OPERATION

3.2 Dismounting the Tractor

Before dismounting, park the tractor and implement on a reasonably level surface, apply the parking brake, idle the engine down, disengage the PTO, and lower the implement to the ground. Shut down the tractor engine according to the operator's manual, remove the key, and wait for all motion to completely stop. Never leave the seat until the tractor, its engine and all moving implement parts are completely stopped.

DANGER!



BEFORE leaving the Tractor seat, always engage the brake and/or set the Tractor transmission in parking gear, disengage the PTO, stop the engine, remove the key, and wait for all moving parts to stop. Place the Tractor shift lever into a low range or parking gear to prevent the Tractor from rolling. Never dismount a Tractor while it is moving or while the engine is running. Operate the Tractor controls from the Tractor seat only. (SG-9)

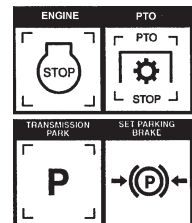

Use hand rails and steps when exiting the tractor. Be careful of your step and use extra caution when mud, ice, snow or other matter has accumulated on the steps or hand rails. Use all handrails and steps for support and never rush or jump off the tractor.

OPERATION

4. STARTING THE TRACTOR

The operator must have a complete understanding of the placement, function, and operational use of all tractor controls before starting the tractor. Review the tractor operator's manual and consult an authorized dealer for tractor operation instructions if needed.

Essential Tractor Controls:

- Locate the light control lever
- Locate the engine shut off control
- Locate the brake pedals and the clutch
- Locate the PTO control
- Locate the 3 point hitch control lever
- Locate the hydraulic remote control levers

Before starting the tractor ensure the following:

- Conduct all pre-start operation inspection and service according to the tractor operator's manual.
- Make sure all guards, shields, and other safety devices are securely in place.
- The parking brake is on.
- The PTO control lever is disengaged.
- The 3-point hitch control lever is in the lowered position.
- The hydraulic remote control levers are in the neutral position.
- The tractor transmission levers are in park or neutral.

Refer to the tractor owner's manual for tractor starting procedures. Only start the tractor while seated and belted in the tractor operator's seat. Never bypass the ignition switch by short circuiting the starter solenoid.

After the tractor engine is running, avoid accidental contact with the tractor transmission to prevent sudden and unexpected tractor movement.

DANGER!



Never run the Tractor engine in a closed building or without adequate ventilation. The exhaust fumes can be hazardous to your health. (SG-23)

DANGER!



Start the Tractor only when properly seated in the Tractor seat. Starting a Tractor in gear can result in injury or death. Read the Tractor operator's manual for proper starting instructions. (SG-13)



OPERATION

OPERATION

5. CONNECTING THE SNOWBLOWER TO THE TRACTOR

Use extreme caution when connecting the snow blower to the tractor. The snow blower should be securely resting at ground level. Keep hands and feet out from under the snowblower and clear of pinch points between the tractor and snowblower.

DANGER!



Always shut the Tractor completely down, place the transmission in park, and set the parking brake before you or anyone else attempts to connect or disconnect the Implement and Tractor hitches. (S3PT-15)

5.1 Connecting the SnowBlower to the Tractor

1. Make sure the tractor is equipped with the correct PTO shaft. Change shafts if needed.
2. Shorten or remove the tractor drawbar to avoid interference when raising and lowering the snow blower.
3. Board the tractor and start the engine. Position the tractor to the snow blower with the 3-point lift arms positioned between the respective set of snow blower A-frame lift lugs. Note: Set the 3-point lift control to "Position Control" so that the lift arms maintain a constant height when attaching the snow blower. See the tractor Operator's Manual for correct settings when attaching 3-point equipment.
4. Turn off the tractor engine and dismount.
5. One lift arm at a time, align arm end hole between the set of A-frame lift lugs. Insert hitch pin through the lug and arm holes and insert retaining pin into hitch pin.
6. Walk around to opposite side and repeat procedure for remaining lift arm and hitch pin.
7. Extend or retract 3-point top link to align its end hole with the holes of the snow blower's top link. Insert the top link hitch pin and insert retaining pin into hitch pin.
8. Adjust any lower link check chains, guide blocks, or sway blocks to prevent the snow blower from swaying side to side and possible contact with tractor rear tires.

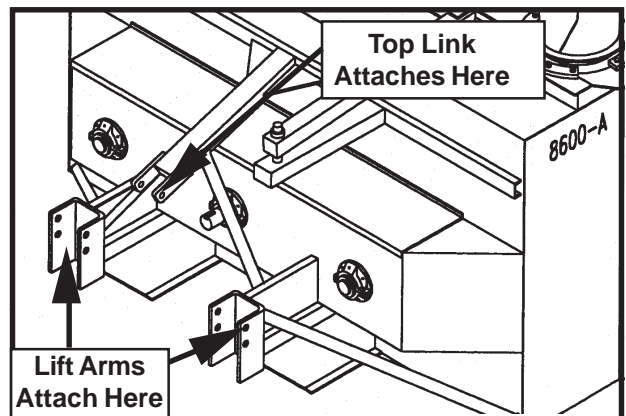

DANGER!



Always shut the Tractor completely down, place the transmission in park, and set the parking brake before you or anyone else attempts to connect or disconnect the Implement and Tractor hitches. (S3PT-15)

OPERATION

DANGER!



Never work under the Implement, the framework, or any lifted component unless the Implement is securely supported or blocked up to prevent sudden or inadvertent falling which could cause serious injury or even death. (SG-14)



DANGER!



Never crawl under a raised Implement supported solely by the Tractor 3-Point hitch. Release of the control lever or mechanical failure will result in the Implement falling and possible injury or death. Always securely block up the Implement before crawling underneath to perform repairs and service. (S3PT-19)

6. DRIVELINE ATTACHMENT

The driveline yokes, gearbox drive shafts, and tractor PTO shaft must be dirt free and greased for attachment.

1. To connect the rear driveline to the tractor PTO output shaft, slide driveline yoke collar and align the grooves and splines of the yoke with those of the PTO shaft. Push the driveline yoke onto the PTO shaft, release the locking collar, and position the yoke until the locking collar balls are seated onto the PTO shaft. Push and pull the driveline back and forth several times to ensure a secure attachment.

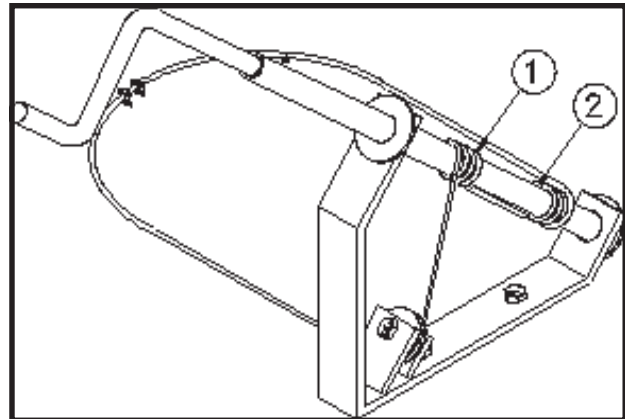

Attach PTO Shaft to snow blower. Install key in shaft, slide yoke over shaft and fasten with setscrew (A). Tighten setscrew (B) at 90° to keyway and lock down with jam nut (C).

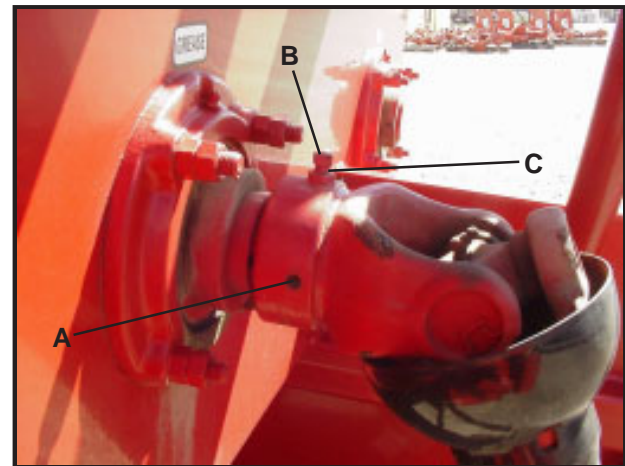

WARNING!



When attaching the Implement input driveline to the Tractor PTO, it is important that the connecting yoke spring activated locking collar slides freely and the locking balls are seated securely in the groove on the Tractor PTO shaft. A driveline not attached correctly to the Tractor PTO shaft could come loose and result in personal injury and damage to the Implement. (S3PT-17)

WARNING!



Before operating the Implement, check to make sure the Implement input driveline will not bottom out or become disengaged. Bottoming out occurs when the inner shaft penetrates the outer housing until the assembly becomes solid-it can shorten no more. Bottoming out can cause serious damage to the Tractor PTO by pushing the PTO into the Tractor and through the support bearings or downward onto the PTO shaft, breaking it off. A broken drive line can cause personal injury. (S3PT-18)

OPERATION

6.1 Connecting Snow Blower Hydraulic Lines to the Tractor

With the tractor shut down and secured in position, relieve hydraulic pressure from the tractor by moving the control levers back and forth several times or placing the levers in the float position. Keep implement hydraulic lines, hoses, quick couplers, and swivels free of contamination. Never leave a disconnected hose end open and cap the tractor hydraulic outlet ports when not in use. If the tractor ports, Snow Blower ports and hydraulic hose ends become contaminated, wipe clean with a rag before connecting.

DANGER!



Do not operate this Equipment with hydraulic oil leaking. Oil is expensive and its presence could present a hazard. Do not check for leaks with your hand! Use a piece of heavy paper or cardboard. High-pressure oil streams from breaks in the line could penetrate the skin and cause tissue damage including gangrene. If oil does penetrate the skin, have the injury treated immediately by a physician knowledgeable and skilled in this procedure. (SG-15)



Hydraulic Cylinder Priming

Hydraulic Cylinder must be filled with hydraulic oil before operating. Hydraulic cylinders and lines are filled by holding the valve control levers in the extended position until the cylinder fully retracts and extends. Place control levers in the float position and repeat process several more times to purge all air from the system.

OPERATION

7. PRE-OPERATION INSPECTION AND SERVICE

Before each use, a pre-operation inspection and service of the snow blower and tractor must be performed. This includes routine maintenance and scheduled lubrication, inspecting that all safety devices are equipped and functional, and performing needed repairs. Do not operate the snow blower and tractor if the pre-operation inspection reveals any condition affecting safe operation. Perform repairs and replacement of damaged and missing parts as soon as noticed. By performing a thorough pre-operation inspection and service, valuable down time and repair cost can be avoided.

DANGER!



Never work under the Implement, the framework, or any lifted component unless the Implement is securely supported or blocked up to prevent sudden or inadvertent falling which could cause serious injury or even death. (SG-14)

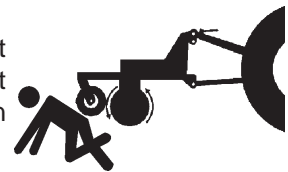

DANGER!



Always disconnect the main PTO Driveline from the Tractor before performing service on the implement. Never work on the implement with the tractor PTO driveline connected and running. Teeth or Drivelines could turn without warning and cause immediate entanglement, injury or death. (SRM-3)

WARNING!



Periodically inspect all moving parts for wear and replace when necessary with authorized service parts. Look for loose fasteners, worn or broken parts, and leaking or loose fittings. Make sure all pins have cotter pins and washers. Serious injury may occur from not maintaining this Implement in good working order. (SG-21)



OPERATION

7.1 Tractor Pre-Operation Inspection/Service

Refer to the tractor operator's manual to ensure a complete pre-operation inspection and scheduled service is performed according to manufacturer recommendations. The following is a partial list of items requiring inspection:

- Tire condition/air pressure
- Wheel lug bolts
- Steering linkage
- PTO shield
- SMV sign is clean and visible
- Tractor's lights are clean and functional
- Tractor Seat belt is in good condition
- Tractor cab or ROPS is in good condition
- ROPS is in the raised position
- No tractor oil leaks
- Radiator free of debris
- Engine oil level and condition
- Engine coolant level and condition
- Power brake fluid level
- Power steering fluid level
- Fuel condition and level
- Sufficient lubrication at all lube points
- Air filter condition



7.2 Snow Blower Pre-Operation Inspection/Service

Before each implement use, a complete inspection and service is required to ensure the implement is in a good and safe working condition. Damaged and/or broken parts should be repaired and/or replaced immediately. To ensure the implement is ready for operation, conduct the following.

- Ensure that the Manual Holder secured to the Implement with the Operator's Manual inside.
- Ensure all decals are in place and legible. Replace missing, worn, and unlegible decals.

NOTE: The snow blower Operator's Manual and affixed Decals contain important instructions on the safe and proper use of the snow blower. Maintain these important safety features on the snow blower in good condition to ensure the information is available to the operator at all times.

- Check that the main driveline is securely attached to the tractor and the locking collar is seated in the groove of the PTO shaft.
- Check that the snow blower driveline is securely attached.
- Inspect that the snow blower pivot pins are the proper size, correctly installed, and secured to the tractor lift arms with retaining pins inserted.



OPERATION

WARNING!



When attaching the Implement input driveline to the Tractor PTO, it is important that the connecting yoke spring activated locking collar slides freely and the locking balls are seated securely in the groove on the Tractor PTO shaft. A driveline not attached correctly to the Tractor PTO shaft could come loose and result in personal injury and damage to the Implement. (S3PT-17)

- Ensure fans are in good working condition and rotate freely.
- Ensure chute ring is rotating freely
- Ensure the driveline integral shields are in good condition and rotate freely.
- Inspect that all bolts and screws are in position and are properly torqued.



OPERATION

DANGER!



Do not put hands or feet near the rotating fan. Fan contact can result in serious injury or even death. Stay away until all motion has stopped and the snow blower is securely blocked up before removing material, performing service, and making repairs. (SSB-6)



DANGER!



Do Not put hands or feet near the rotating auger. Auger contact can result in serious injury or even death. Stay away until all motion has stopped and the snow blower is securely blocked up before removing material, performing service, and making repairs. (SSB-5)



- Ensure the drive chain shield is in place and in good repair.
- Ensure the tractor PTO master shield is in place, lowered and in good condition.
- Inspect that the chute cable is not excessively frayed or worn out.
- Inspect the condition of the drive chain. Retighten if slack exceeds 3/4".

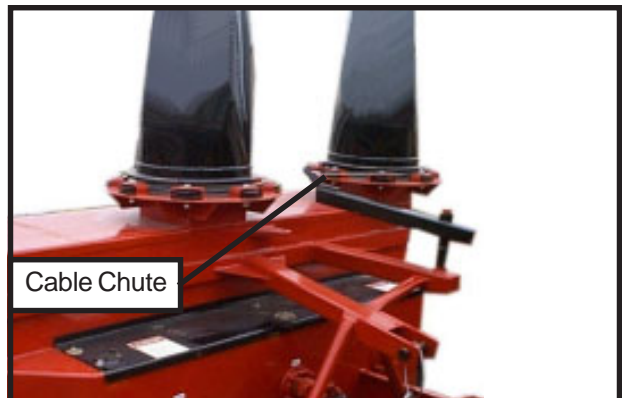

OPERATION

- Perform scheduled lubrication as specified in the maintenance section.
- Inspect the oil level and condition of oil reservoir and replenish if needed. (Add specific type oil if low)
- Ensure there are no oil leaks and fittings are properly connected.



DANGER!



Never work under the Implement, the framework, or any lifted component unless the Implement is securely supported or blocked up to prevent sudden or inadvertent falling which could cause serious injury or even death. (SG-14)

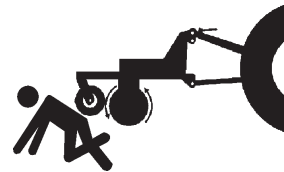

DANGER!



Do not operate this Equipment with hydraulic oil leaking. Oil is expensive and its presence could present a hazard. Do not check for leaks with your hand! Use a piece of heavy paper or cardboard. High-pressure oil streams from breaks in the line could penetrate the skin and cause tissue damage including gangrene. If oil does penetrate the skin, have the injury treated immediately by a physician knowledgeable and skilled in this procedure. (SG-15)



Operation and Service

1. Before operating each season, grease the blower completely as per lubrication guide.
2. To prevent damage to the driveline, before operating the blower raise the three-point and check the **PTO** knuckle. **DO NOT** exceed 30 degrees. Set the stop on the three-point lift to prevent accidental overlift.
3. For best operation, travel at speeds that will let the blower efficiently handle the load. Speeds may vary with depth and conditions of the snow. **DO NOT** move the blower at speeds that will push the snow. Avoid bulldozing into snowbanks as this may possibly plug the spouts and put undue stress to all driveline components.
4. If the blower becomes overloaded in deep snow, raise the machine and remove the upper layer, move ahead, and lower the blower for another pass.
5. After the first ten hours of operation, check and retighten all setscrews and bolts. Check the roller chain for tightness and adjust the idler sprockets accordingly.
6. The oil bath housing for the drive assembly contains 5 gallons of standard SAE #5 wt. oil. The oil bath assures long sprockets, chain life, and dissipates heat caused by moving parts. Periodically check the oil level and add if necessary.
7. Each fan is protected by a shear bolt located at the back of the fan shaft. Replace as required. Use only Rhino shear bolts. **CAUTION!** Using a higher grade bolt may damage snowblower.

OPERATION

8. DRIVING THE TRACTOR AND SNOW BLOWER

Safe tractor transport requires the operator possess a thorough knowledge of the model being operated and precautions to take while driving with an attached implement. Ensure the tractor has the capacity to handle the weight of the implement and the tractor operating controls are set for safe transport. To ensure safety while driving the tractor with an attached implement, review the following.

WARNING!  Transport only at safe speeds. Serious accidents and injuries can result from operating equipment at unsafe speeds. Understand the Tractor and Implement and how it handles before transporting on streets and highways. Make sure the Tractor steering and brakes are in good condition and operate properly. Before transporting the Tractor and Implement, determine the safe transport speeds for you and the equipment. Make sure you abide by the following rules:

1. Test the Tractor at a slow speed and increase the speed slowly. Apply the Brakes smoothly to determine the stopping characteristics of the Tractor and Implement. As you increase the speed of the Tractor the stopping distance increases. Determine the maximum safe transport speed for you and this Equipment.
2. Test the equipment at a slow speed in turns. Increase the speed through the turn only after you determine that it is safe to operate at a higher speed. Use extreme care and reduce your speed when turning sharply to prevent the Tractor and Implement from turning over. Determine the maximum safe turning speed for you and this equipment before operating on roads or uneven ground.
3. Only transport the Tractor and Implement at the speeds that you have determined are safe and which allow proper control of the equipment.

Be aware of the operating conditions. Do not operate the Tractor with weak or faulty brakes. When operating down a hill or on wet or rain slick roads, the braking distance increases, use extreme care and reduce your speed in these conditions. When operating in traffic, always use the Tractor's flashing warning lights and reduce your speed. Be aware of traffic around you and watch out for the other guy. (SG-19)

DANGER!



This Implement is wider than the Tractor. Be careful when operating or transporting this equipment to prevent the Implement from running into or striking sign posts, guard rails, concrete abutments or other solid objects. Such an impact could cause the Implement and Tractor to pivot violently resulting in loss of steering control, serious injury, or even death. Never allow the Implement to contact obstacles. (S3PT-12)

OPERATION

8.1 Starting the Tractor

The procedure to start the tractor is model specific. Refer to the tractor operator's manual for starting procedures for your particular tractor. Consult an authorized dealer if the starting procedure is unclear. Ensure the 3-point control lever is in the lowered position and the PTO is disengaged before starting the tractor.



8.2 Brake and Differential Lock Setting

Make sure the tractor brakes are in good operating condition. Tractor brakes can be set to operate independently allowing single rear wheel braking action or locked together to provide simultaneous rear wheel braking. FOR MOST DRIVING AND SNOW BLOWING CONDITIONS, THE BRAKE PEDALS SHOULD BE LOCKED TOGETHER TO PROVIDE THE MOST EFFECTIVE BRAKING ACTION.

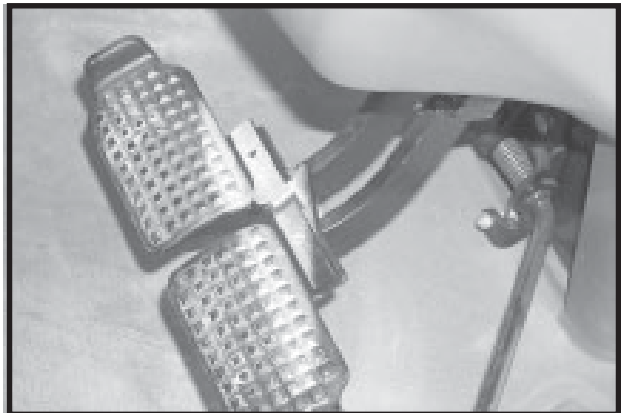

WARNING!



Be aware of the operating conditions. Do not operate the Tractor with weak or faulty brakes. When operating down a hill or on wet or rain slick roads, the braking distance increases; use extreme care and reduce your speed in these conditions. When operating in traffic, always use the Tractor's flashing warning lights and reduce your speed. Be aware of traffic around you and watch out for the other guy.

Always disengage the tractor differential lock when turning. When engaged the differential lock will prevent or limit the tractor from turning. During normal operating conditions, locking the differential provides no benefit and should not be used.

OPERATION

8.3 Driving the Tractor and Snow Blower

Start off driving at a slow speed and gradually increase your speed while maintaining complete control of the tractor and snow blower. Moving slowly at first will also prevent the tractor from rearing up and loss of steering control. The tractor should never be operated at speeds that cannot be safely handled or which will prevent the operator from stopping quickly during an emergency. If the power steering or engine ceases operating, stop the tractor immediately as the tractor will be difficult to control.

WARNING!



Allow sufficient clearance for the Implement to swing outward while turning. Implements carried behind the Tractor will swing outside the tire path when making turns. Contacting a solid object while turning will cause equipment damage and possible injury. (S3PT-20)

Perform turns with the tractor and snow blower at slow speeds to determine how the tractor with the attached implement handles a turn. When operating the snow blower the overall working length of the unit is increased. Allow additional clearance for the snow blower when turning. Extra precaution should be taken to avoid hitting parked vehicles, sign, road structures, bystanders, and animals due to the overall length and width of the implement.



To avoid overturns, drive the tractor with care and at safe speeds, especially when operating over rough ground, crossing ditches or slopes, and turning corners. Rear tractor tire spacing should be increased when working on inclines or rough ground to reduce the possibility of tipping.



Use extreme caution when operating on steep slopes. Keep the tractor in a low gear when going downhill. DO NOT coast or free-wheel downhill.

WARNING!



Do not let the auger turn when the implement is raised for any reason, including clearance or for turning. Raising the implement exposes the auger which creates a potentially serious hazard and could cause serious injury or even death from objects thrown from the auger.



OPERATION

8.4 Crossing Ditches and Steep Inclines

WARNING!



Damage resulting from over-collapse of the driveline's inner profile and its outer housing may allow the driveline to come loose from the Tractor which could cause bodily injury to the operator or bystanders and/or extensive damage to the Tractor or Implement

When confronted with an incline or ditch, do not approach from an angle which is perpendicular or straight on as damage to over collapse of the driveline may occur.

When crossing such terrain, the implement should be fully lowered for a lower center of gravity and added stability.

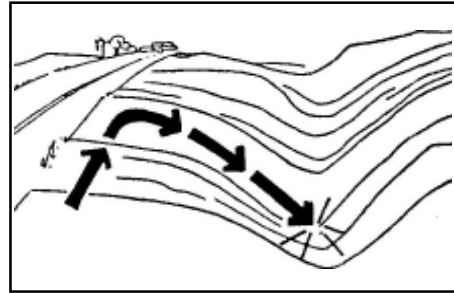

INCORRECT: DO NOT approach ditch straight on.

Inclines and ditches should be approached along a line which is at an angle as shown. This type of path will reduce the possibility of over-collapse of the driveline and resulting damage. If the gradient is so steep that such as approach increases the possibility of a tractor roll-over, select an alternate crossing path.

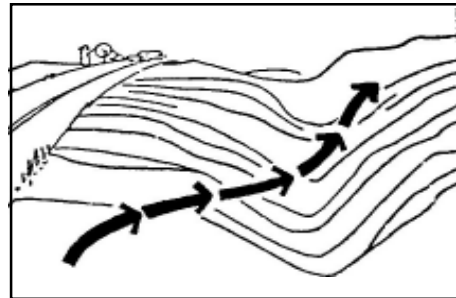

CORRECT: Approach ditch at an angle

When operating the tractor and implement across slopes and inclines, through ditches, and other uneven terrain conditions, it is important to maintain sufficient deck and frame ground clearance. If too much snow is being carried in to the snow blower, reduce the working depth. Ground contact also produces a severe shock load on the snow blower drive and resulting in possible damage and premature wear.

OPERATION

9. Operating the Tractor and Snow Blower

THE OPERATOR MUST COMPLETELY UNDERSTAND HOW TO OPERATE THE TRACTOR AND SNOW BLOWER AND ALL CONTROLS BEFORE ATTEMPTING TO OPERATE. The operator must read and understand the Safety and Operation Sections of the snow blower and tractor operator's manuals. These manuals must be read and explained to any operator who cannot read. Never allow someone to operate the snow blower and tractor without complete operating instructions.

Before starting any operation, the operator must become familiar with the area to be snow blown and any obstacles and hazards contained within to ensure safety to the operator, bystanders, and equipment. Special attention should be paid to foreign debris, rough terrain, steep slopes, and passersby and animals in the area.



WARNING!



Many varied objects, such as wire, cable, rope, or chains, can become entangled in the rotating parts of the Implement. These objects could then swing outside the housing at greater velocities than the auger. Such a situation is extremely hazardous and could result in serious injury or even death. Inspect the cutting area for such objects before working in the area. Remove any such objects from the site. Never allow the auger to contact such objects. (STL-6)

OPERATION

9.1 Foreign Debris Hazards

Remove all foreign objects and debris. If objects are too big to remove, mark them clearly and be sure to prevent the implement from contacting them.



OPERATION

If you hit a solid object or foreign debris stop the implement and tractor at once. Immediately idle the engine speed and disengage the PTO. Wait for all rotating motion to stop, then raise the implement and move the tractor and implement off the object. Inspect the area and mark the location of the debris. Inspect the condition of the implement and make any needed repairs immediately. Make sure the auger is not damaged before resuming operation.

Always wear your seat belt securely fastened and only operate the tractor and snowblower with the ROPS in the raised position. If the tractor or snow blower hits a tree stump or bump, a sudden movement could throw you off of the seat and under the tractor and snowblower. The seat belt is your best protection from falling off the tractor and the ROPS provides protection from being crushed during a tractor roll-over.

WARNING!



Be sure you have adequate knowledge of the property you will be working on. Take time to make yourself aware of any area underground lines or cables. Contact with buried lines or cable could result in **serious injury** or **death**. (STL-1)

DANGER!



There are obvious and hidden potential hazards in the operation of this Snow Blower. REMEMBER! This machine is often operated in deep snow where vision is reduced. The fan blades of this Snow Blower can throw objects for great distances. Serious injury or even death may occur unless care is taken to insure the safety of the operator, bystanders, or passersby in the area. Do not operate this machine with anyone in the immediate area. Stop Snow Blowing if anyone is within 200 feet of Snow Blower. (SSB-11)

9.2 Engaging the Power Take Off (PTO)

Before engaging the PTO, make certain that the area is clear of bystanders and passersby. Set the tractor engine speed at approximately 1,000 RPM before engaging the PTO. Shift the PTO control to the on position, and slowly increase the engine speed until the PTO is operating at the rated speed. If you hear unusual noises or see or feel abnormal vibrations, disengage the PTO immediately. Inspect the snow blower to determine the cause of the noise or vibration and repair the abnormality.

DANGER!



Do not put hands or feet under rotating auger. Auger Contact can result in serious injury or even death. Stay away until all motion has stopped and the frame is securely blocked up. (STL-3)

DANGER!



Make sure the PTO shield, integral driveline shields, and input shields are installed when using PTO-driven equipment. Always replace any shield if it is damaged or missing. (S3PT-8)



9.3 PTO RPM and Ground Speed

Ground speed for snowblower will depend upon the condition of the area to be snowblown. Travel at speeds that will let the blower efficiently handle the load. Do not move the blower at speeds that will push the snow. Operate the implement at its full rated PTO speed to maintain speed for snowblower operation. Refer to the tractor operator's manual or the tractor instrument panel for the engine speed and gear to provide the required PTO and desired ground speed. Make sure that the snowblower is operating at its full rated speed before entering the field or paved areas to be snowblown. If it becomes necessary to temporarily regulate engine speed, increase or decrease the throttle gradually. Ground speed is achieved by transmission gear selection and not by the engine operating speed. The operator may be required to experiment with several gear range combinations to determine the best gear and range which provides the most ideal performance from the snowblower and most efficient tractor operation. As the severity of operation conditions increase, the ground speed should be decreased by selecting a lower gear to maintain the proper operating PTO speed.

OPERATION

WARNING! Blow snow at the speed that you can safely operate and control the Tractor and Snow Blower. Safe speed depends on terrain and snow conditions. Normal ground speed range is from 0 to 5 mph. Use slow speeds when operating on or near steep slopes, ditches, drop-offs, overhead obstructions, power lines, or when debris and foreign objects are to be avoided. (SSB-4)



10 Operating the Snow Blower

Before operating the snow blower recheck that all fasteners, nuts, bolts, screws and cotter pins are in place and all bolts are torqued to specification.



WARNING! Only operate the snow blower in conditions where you have clear visibility in daylight or with adequate artificial lighting. Never snow blow in darkness or in conditions where you cannot clearly see at least 100 yards in front and to the sides of the Tractor and Snow Blower. Make sure that you can clearly see and identify passersby, steep slopes, ditches, drop-offs, overhead obstructions, power lines, debris and foreign objects. If you are unable to clearly see these types of items, discontinue snow blowing. (SSB-1)



DANGER! DO NOT operate this Implement on a Tractor that is not properly maintained. Should a mechanical or Tractor control failure occur while operating, immediately shut down the Tractor and perform repairs before resuming operation. Serious injury and possible death could occur from not maintaining this Implement and Tractor in good operating condition. (SG-36)



WARNING! Do not snow blow with two machines in the same area except with Cab tractors with the windows closed. (SGM-11)



OPERATION

OPERATION

DANGER!

Never direct discharge of snow towards people, pets, or property.



CAUTION!

Excessive speed of drop may cause damage or injury. Fully lowering implement should require at least two seconds.



CAUTION!

Do not operate the snow blower PTO drive in the fully raised position.



WARNING!

Stop engine, disengage power take-off, and remove ignition key whenever leaving tractor operating position.



When implement is ready to snow blow do not use the snow blower to **PUSH SNOW!** Let the machine work its way through deep drifts and hard packed snow. For best results keep the snow blower fan running at rated PTO speed. If the tractor engine starts to labour, gear down.

Do not continuously operate the snow blower in transport position, as this will shorten the life of the universal joints.

Tractor chains and weighted tires will increase traction and improve performance especially in icy conditions.

The casting chute should not plug during normal operation. However, if fan RPM is allowed to drop drastically in wet, sticky conditions, or if a sheat bolt breaks in the fan the casting chute may plug. If the chute should plug, try raising the snow blower to transport position and the dropping it suddenly, if this fails to clear blockage, the casting chute will have to be manually cleared.

CAUTION!

Do not allow snow or ice to build up around the chute rotation mechanism as this may cause damage to snow blower chute or the chute rotator mechanism.



When operating the snow blower occasionally rotate the chute left then right to clear the front housing of snow.

OPERATION

DANGER!



Snow Blowers are capable under adverse conditions of throwing objects for great distances (200 feet or more) and causing serious injury or death. Follow safety messages carefully. (SSB-7)



STOP SNOW BLOWING IF PASSERSBY ARE WITHIN 200 FEET.

WARNING!



Do Not blow snow with two machines in the same area except with cab tractors with the windows closed. (SSB-10)

DANGER!



Operate the Tractor and/or Implement controls only while properly seated in the Tractor seat with the seat belt securely fastened around you. Inadvertent movement of the Tractor or Implement may cause serious injury or death. (SG-29)

Use extreme care when transporting the snow blower on public highways and roads. The combination of snow blower and the tractor is longer in length. The implement is also wider than the tractor. Allow ample clearance when transporting the tractor and implement to insure that they do not contact any bystanders, signs, road structures, or other vehicles.

OPERATION

10.1 Shutting Down the Implement

Tractor & Snow Blower

To shut down the implement, first bring the tractor to a complete stop. Then slow down the snow blower by reducing the engine speed before disengaging the PTO. Wait for all rotating motion to stop before proceeding to drive or shut down the tractor.

Park the tractor on a level surface, place the transmission in park or neutral and apply the parking brake, lower the attached implement to the ground, shut down the engine, remove the key, and wait for all motion to come to a complete stop before exiting the tractor.



OPERATION

11. DISCONNECTING SNOW BLOWER FROM THE TRACTOR

DANGER!



Always shut the Tractor completely down, place the transmission in park, and set the parking brake before you or anyone else attempts to connect or disconnect the Implement and Tractor hitches. (S3PT-15)

Before disconnecting the implement, the PTO must be disengaged and auger rotation at a complete stop. Move the implement to a level storage location and lower the implement to the ground. If the implement is not resting securely on the ground, block the implement up securely before attempting to disconnect it from the tractor.

Use extreme care to keep feet and hands out from under the implement and clear of any pinch points when disconnecting the implement from the tractor.

DANGER!



Never stand or allow another person to stand between a running Tractor and the Unit when disconnecting the Implement from the Tractor 3-point hitch. Always shut the Tractor off completely and set the parking brake before attempting to disconnect the Implement pins from the Tractor hitch.

To disconnect the implement, first extend the tractor 3-point hitch top link to remove tension on the top link hitch pin. When the pin is loose and easy to rotate, remove the pin from the implement. Next remove both lower hitch pins.



After disconnecting the 3 lift points, remove the implement driveline from the tractor PTO shaft. Lay the driveline down carefully to avoid damaging the driveline or its shield. Do not let the driveline fall into mud or dirt, which can contaminate the bearing and shorten the life of the driveline.

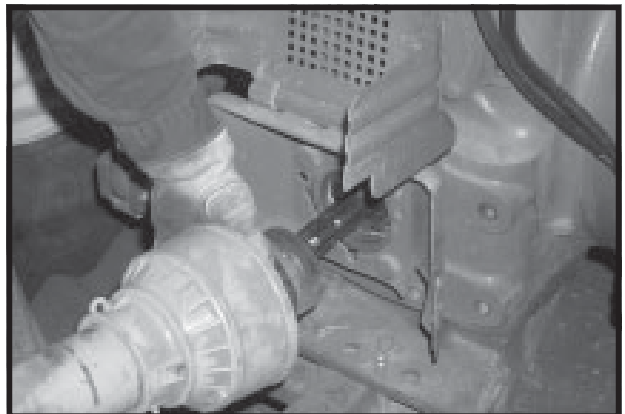

WARNING!



Do not let the auger turn when the implement is raised for any reason, including clearance or for turning. Raising the implement exposes the auger which creates a potentially serious hazard and could cause serious injury or even death from objects thrown from the auger.



OPERATION

WARNING!



Relieve hydraulic pressure prior to doing any maintenance or repair work on the Implement. Place the Implement on the ground or securely blocked up, disengage the PTO, and turn off the tractor engine. Push and pull the Remote Cylinder lever in and out several times prior to starting any maintenance or repair work. (S3PT-9)



12. SNOW BLOWER STORAGE

Properly preparing and storing the snow blower at the end of the season is critical to maintaining its appearance and to help ensure years of dependable service. The following are suggested storage procedures:

1. Thoroughly clean all debris off the implement to prevent damage from rotting grass and standing water.
2. Lubricate all implements points and fill gearbox oil levels as detailed in the maintenance section.
3. Tighten all bolts and pins to the recommended torque.
4. Check the implement for worn and damaged parts. Perform repairs and make replacements immediately so that the implement will be ready for use at the start of the next season.
5. Store the implement in a clean, dry place with the implement resting securely on blocks or at ground level.
6. Keep the drivelines yokes or hydraulic hoses from sitting in water, dirt and other contaminants.
7. Use spray touch-up enamel where necessary to prevent rust and maintain the appearance of the implement.



OPERATION

DANGER!



Never allow children to play on or around the Tractor and Implement. Children can slip or fall off the Equipment and be injured or killed. Children can cause the Implement to shift or fall crushing themselves and others. (SG-25)

OPERATION

13. TRANSPORTING THE TRACTOR AND SNOW BLOWER

Inherent dangers of operating the tractor and implement and the possibility of accidents are not left behind when you finish snow blowing an area. Therefore, the operator must employ good judgement and safe operation practices when transporting the tractor and implement between locations. By using good judgement and following safe transport procedures, the possibility of accidents while moving between locations can be substantially minimized.

DANGER!



Never allow children or other persons to ride on the Tractor or Implement. Falling off can result in serious injury or death.

(SG-10)



Before transporting the tractor on a public roadway or boarding a trailer for transport, the tractor brake pedals should be locked together. Locking the pedals ensures that both wheels brake simultaneously while stopping, especially when making an emergency stop.

Use extreme caution and avoid hard applications of the tractor brakes when towing heavy loads at road speeds. Never tow the implement at speeds greater than 20 MPH.

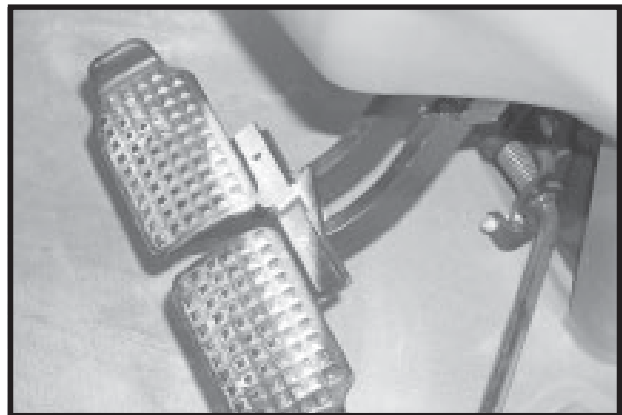

If the tractor's hydraulic pump is not independent of the tractor PTO, or if the tractor PTO has to be run to have hydraulic power, disconnect the snow blower driveline from the tractor PTO output shaft. Secure the driveline to the implement deck to prevent driveline damage or loss during transport.

WARNING!



In wet conditions where there is a likelihood of material collecting on the Implement, make certain that this material is removed before travelling on public roadways. (STL-7)

OPERATION

OPERATION

13.1 Transporting on Public Roadways

DANGER!



Never allow children or other persons to ride on the Tractor or Implement. Falling off can result in serious injury or death. (SG-10)



WARNING!



Make certain that the “Slow Moving Vehicle” (SMV) sign is installed in such a way as to be clearly visible and legible. When transporting the Equipment use the Tractor flashing warning lights and follow all local traffic regulations. (SG-6)

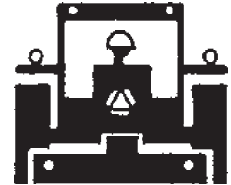

Extreme caution should be used when transporting the tractor and implement on public roadways. The tractor must be equipped with all required safety warning features including a SMV emblem and flashing warning lights to alert drivers of the tractor's presence. Remember that roadways are primarily designed for automotive drivers and most drivers will not be looking out for you, therefore, you must look out for them. Check your side view mirrors frequently and remember that vehicles will approach quickly because of the tractor's slower speed. Be extremely cautious when the piece of equipment that you are towing is wider than the tractor tire width and/or extends beyond your lane of the road.



The SMV (Slow-Moving Vehicle) emblem is universal symbol used to alert drivers of the presence of equipment traveling on roadways at a slow speed. SMV signs are a triangular bright orange with reflective red trim for both easy day and night visibility. Make sure the SMV sign is clean and visible from the rear of the unit before transporting the tractor and implement on a public roadway. Replace the SMV emblem if faded, damaged, or no longer reflective.



Make sure that all tractor flashing warning lights, headlights, and brake/taillights are functioning properly before proceeding onto public roads. While newer model tractors have plenty of lighting to provide warning signals and operating lighting, most older models were only equipped with operating lights. Consult an authorized tractor dealer for lighting kits and modifications available to upgrade the lighting on older tractor models.

OPERATION

When operating on public roads, have consideration for other road users. Pull to the side of the road occasionally to allow following traffic to pass. Do not exceed the legal speed limit set in your area for agricultural tractors. Always stay alert when transporting the tractor and implement on public roads. Use caution and reduce speed if other vehicles or pedestrians are in the area.

Reduce speed before turning or applying the brakes. Ensure that both brake pedals are locked together when operating on public roads.

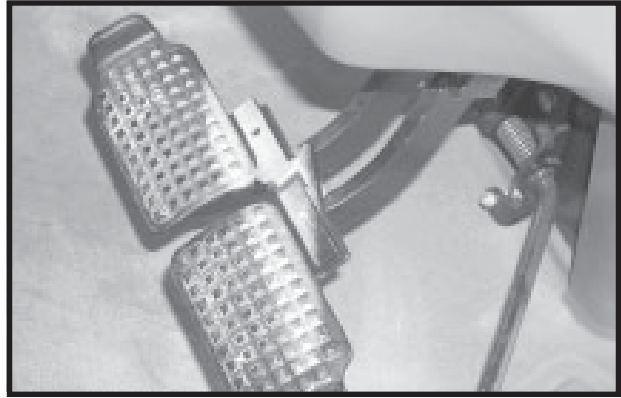

DANGER!



This Implement is wider than the Tractor. Be careful when operating or transporting this equipment to prevent the Implement from running into or striking sign posts, guard rails, concrete abutments or other solid objects. Such an impact could cause the Implement and Tractor to pivot violently resulting in loss of steering control, serious injury, or even death. Never allow the Implement to contact obstacles. (S3PT-12)

WARNING!



Allow sufficient clearance for the Implement to swing outward while turning. Implements carried behind the Tractor will swing outside the tire path when making turns. Contacting a solid object while turning will cause equipment damage and possible injury. (S3PT-20)

DANGER!



Be particularly careful when transporting the Implement using the tractor. Turn curves or go up or down hills only at a low speed and at a gradual steering angle. Make certain that at least 20% of the tractor's weight is on the front wheels to maintain safe steering. Slow down on rough or uneven surfaces. (STI-1)

OPERATION

WARNING!



Secure the Implement for transport before traveling on public roads. For pull-type Implements, secure the center axle using cylinder stops or transport pin and properly attach a safety chain between the Implement and Tractor. (STI-7)

WARNING!



Transport only at safe speeds. Serious accidents and injuries can result from operating this equipment at unsafe speeds. Understand the Tractor and Implement and how it handles before transporting on streets and highways. Make sure the Tractor steering and brakes are in good condition and operate properly.



Before transporting the Tractor and Implement, determine the safe transport speeds for you and the equipment. Make sure you abide by the following rules:

1. Test the tractor at a slow speed and increase the speed slowly. Apply the Brakes smoothly to determine the stopping characteristics of the Tractor and Implement. As you increase the speed of the Tractor the stopping distance increases. Determine the maximum safe transport speed for you and this Equipment.
2. Test the equipment at a slow speed in turns. Increase the speed through the turn only after you determine that it is safe to operate at a higher speed. Use extreme care and reduce your speed when turning sharply to prevent the tractor and implement from turning over. Determine the maximum safe turning speed for you and your equipment before operating on roads or uneven ground.
3. Only transport the Tractor and Implement at the speeds that you have determined are safe and which allow you to properly control the equipment.

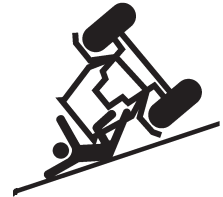

Be aware of the operating conditions. Do not operate the Tractor with weak or faulty brakes. When operating down a hill or on wet or rain slick roads, the braking distance increases: use extreme care and reduce your speed. When operating in traffic always use the Tractor's flashing warning lights and reduce your speed. Be aware of traffic around you and watch out for the other guy. (SG-19)

OPERATION

14 Hauling the Tractor and Snow Blower

Before transporting a loaded tractor and implement, measure the height and width dimensions and gross weight of the complete loaded unit. Ensure that the load will be in compliance with the legal limits set for the areas that will be traveled through.



Use adequately sized and rated trailers and equipment to transport the tractor and implement. Consult an authorized dealer to determine the proper equipment required. Using adequately sized chains, heavy duty straps, cables and/or binders, securely tie down both the front and rear of the tractor utilizing the proper tie down locations as specified by the tractor manufacturer.



Arrange the chains so that when tightened, the chains are pulling downward and against themselves. Carefully tighten the securing chains or other fasteners used as much as possible using boomers or binders to apply maximum tension. Use extreme care when attaching and removing the securing devices as the extreme tension involved when released has the potential to inflict serious injury.

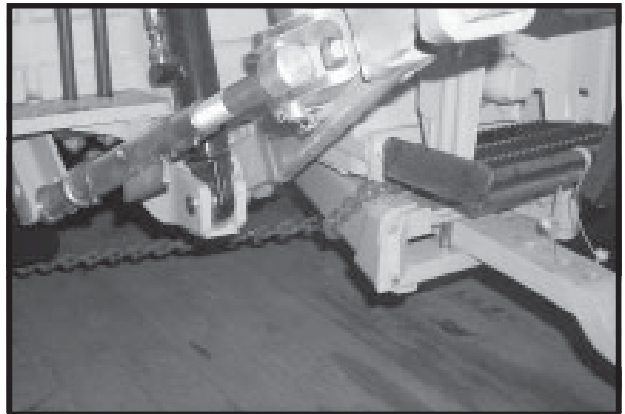

While hauling the tractor and implement, make occasional stops to check that the tractor and implement have not moved or shifted and that the securing chains have maintained tension. If during transport a hard braking, sharp turning, or swerving action was performed, stop at the next safe location to inspect the security of the load.

OPERATION

15. TROUBLE SHOOTING GUIDE (SNOW BLOWER)

TROUBLE	POSSIBLE CAUSE	POSSIBLE REMEDY
Excessive power required to operate snow blower	Operate in too high a gear	Gear down tractor
	Blade scraping ground	Increase unit height
Tractor wheel slippage	Ballast or traction	Install chains
Excessive Mechanical noise	Loose bolts	Tighten bolts
	Worn universal joints bearings	see your dealer
	Worn bearings	see your dealer
Does not throw snow	Check valve installed wrong	Install check valve as shown on parts page
Fan Does not Work	Fan Shear Bolt Broken	Replace Shear Bolt
	One of shear bolts in fan is sheared	Replace Shear Bolt

MAINTENANCE SECTION

MAINTENANCE

Nuts And Bolts

1. Check all nuts and bolts for tightness after the first 5 hours of operation then yearly.

IMPORTANT: Shear bolts should not be over tightened, as this may cause unpredictable shearing action.

Drive Chain

1. Retighten the auger drive chain when slack exceeds 3/4 inch at the center of the bottom chain section.

2. The drive chain is tightened by loosening the bolts on the idler roller plate and forcing the idler against the chain, then retightening the bolts.

3. **DO NOT OVER TIGHTEN** as this will increase wear of the idler roller. Allow approximately 3/8 inch of slack up or down at the center of the bottom chain section.

Shear Bolts

1. **IMPORTANT:** If a shear bolt breaks during operation immediately shut down the tractor and replace the shear bolt.

2. The shear bolts used on these Alamo Industrial snowblower fans are part number 00783578. This shear bolt is machined around the shank to facilitate shear at the protected fan load.

3. Specified shear bolts and their locations are listed below:

NOTE: Special machined bolt required for fan shear.

IMPORTANT: Tighten nut only enough to draw the shear plates together. Do not over tighten nut. Occasionally apply grease to the shear plates.

IMPORTANT: Replacement of the shear bolt with one of any other grade or size will be considered an unauthorized modification and the warranty will be void.

MAINTENANCE

P.T.O. SHAFT

GREASE EVERY 5 HOURS

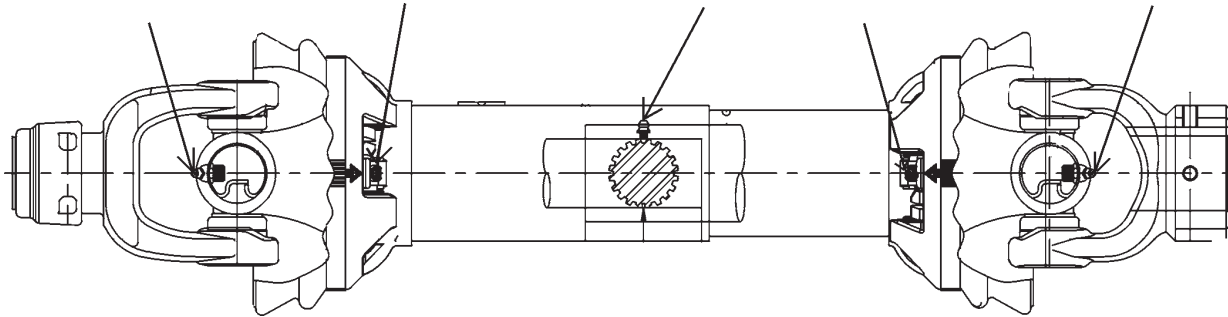

**PUSH PTO SHAFT TOGETHER UNTIL GREASE FITTING
LINES UP WITH SLOT IN SHIELD.
GREASE EVERY 5 HOURS**

SPOUT BRACKET

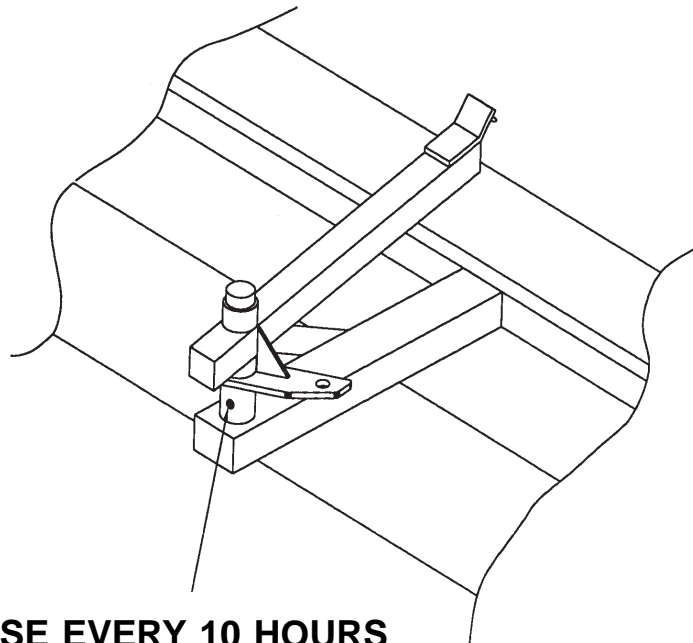

GREASE EVERY 10 HOURS

MAINTENANCE

MAINTENANCE

FANS

Grease every 50 hours or every tenth time the Shear Bolt is sheared.

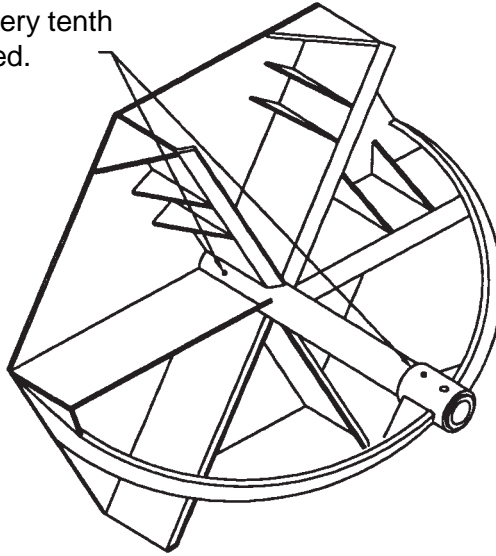

OIL RESERVOIR

Use SAE 5wt. oil or equivalent for oil bath. (5 gallon capacity)

Remove lid to grease Internal Pillow Block Bearing.

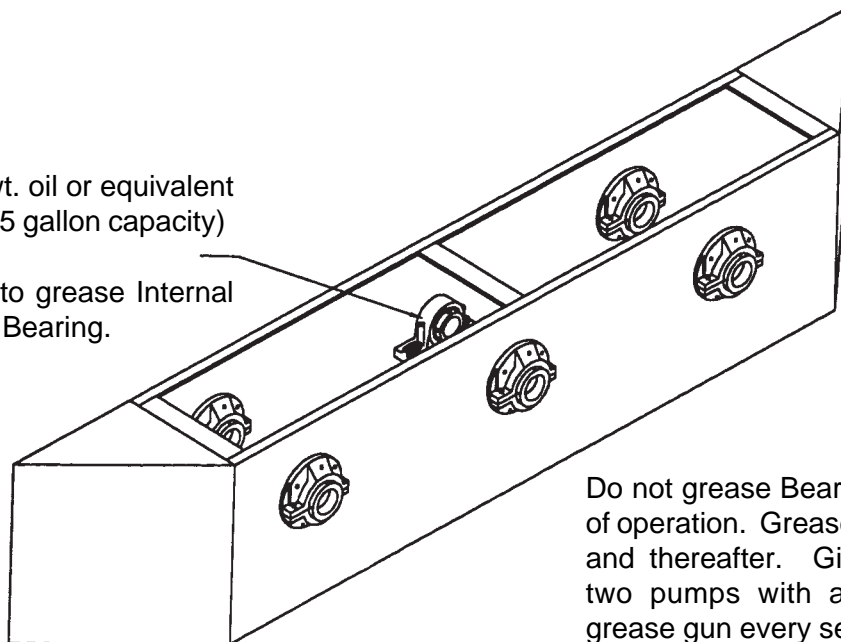

Do not grease Bearings the first year of operation. Grease the second year and thereafter. Give each Bearing two pumps with a hand operated grease pumps every season.

MAINTENANCE

Grease Schedule

1. Grease should meet the following recommendations:

SAE Multi purpose grease

SAE Multi purpose grease containing 3 to 5 per cent molybdenum disulfide

Below 0° C (32° F) use SAE (NLGI) #0 or #1

Above 0° C (32° F) use SAE (NLGI) #2

2. Drive Chain

The Drive Chain is operating in an oil bath. Check level using a dip stick. Complete assembly contains 5 gallons of SAE #5 wt. oil. Add if necessary.

3. Universal Joint Assemblies

Apply grease to the grease nipple on the slip sleeve of the universal assembly every 5 hours of operation.

NOTE: The snow blower may have to be raised or lowered and the safety shields rotated to fully expose the grease nipple.

Occasionally pull the driveline halves apart and apply grease to all sides of the spline shaft.

IMPORTANT: If the universal joint sliding members are allowed to dry out to the point where two halves cannot slip freely, damage to the snow blower or tractor may occur.

4. Universal Joint Cross Kits

Every 10 hours of operation (minimum) lubricate the grease fittings on the universal joint cross kits. If grease is seen leaking out of the cross kit bearings, this is an indication that bearings are running hot. Under these conditions regrease the cross kits more frequently.

Apply only one or two strokes from a hand type grease gun. If fittings are over lubricated seals may be damaged.

Grease to the entire under side of the chute.

STORAGE

Wash any dirt or salt off the snow blower.

Remove drive chains and submerge in oil

Smear grease over any exposed hydraulic cylinder shafts

ALAMO INDUSTRIAL

LIMITED WARRANTY

1. LIMITED WARRANTIES

- 1.01. Alamo Industrial warrants for one year from the purchase date to the original non-commercial, governmental, or municipal purchaser ("Purchaser") and warrants for six months to the original commercial or industrial purchaser ("Purchaser") that the goods purchased are free from defects in material or workmanship.
- 1.02. Manufacturer will replace for the Purchaser any part or parts found, upon examination at one of its factories, to be defective under normal use and service due to defects in material or workmanship.
- 1.03. This limited warranty does not apply to any part of the goods which has been subjected to improper or abnormal use, negligence, alteration, modification, or accident, damaged due to lack of maintenance or use of wrong fuel, oil, or lubricants, or which has served its normal life. This limited warranty does not apply to any part of any internal combustion engine, or expendable items such as blades, shields, guards, or pneumatic tires except as specifically found in your Operator's Manual.
- 1.04. Except as provided herein, no employee, agent, Dealer, or other person is authorized to give any warranties of any nature on behalf of Manufacturer.

2. REMEDIES AND PROCEDURES.

- 2.01. This limited warranty is not effective unless the Purchaser returns the Registration and Warranty Form to Manufacturer within 30 days of purchase.
- 2.02. Purchaser claims must be made in writing to the Authorized Dealer ("Dealer") from whom Purchaser purchased the goods or an approved Authorized Dealer ("Dealer") within 30 days after Purchaser learns of the facts on which the claim is based.
- 2.03. Purchaser is responsible for returning the goods in question to the Dealer.
- 2.04. If after examining the goods and/or parts in question, Manufacturer finds them to be defective under normal use and service due to defects in material or workmanship, Manufacturer will:
 - (a) Repair or replace the defective goods or part(s) or
 - (b) Reimburse Purchaser for the cost of the part(s) and reasonable labor charges (as determined by Manufacturer) if Purchaser paid for the repair and/or replacement prior to the final determination of applicability of the warranty by Manufacturer.The choice of remedy shall belong to Manufacturer.
- 2.05. Purchaser is responsible for any labor charges exceeding a reasonable amount as determined by Manufacturer and for returning the goods to the Dealer, whether or not the claim is approved. Purchaser is responsible for the transportation cost for the goods or part(s) from the Dealer to the designated factory.

3. LIMITATION OF LIABILITY.

- 3.01. MANUFACTURER DISCLAIMS ANY EXPRESS (EXCEPT AS SET FORTH HEREIN) AND IMPLIED WARRANTIES WITH RESPECT TO THE GOODS INCLUDING, BUT NOT LIMITED TO, MERCHANTABILITY AND FITNESS FOR A PARTICULAR PURPOSE.
- 3.02. MANUFACTURER MAKES NO WARRANTY AS TO THE DESIGN, CAPABILITY, CAPACITY, OR SUITABILITY FOR USE OF THE GOODS.
- 3.03. EXCEPT AS PROVIDED HEREIN, MANUFACTURER SHALL HAVE NO LIABILITY OR RESPONSIBILITY TO PURCHASER OR ANY OTHER PERSON OR ENTITY WITH RESPECT TO ANY LIABILITY, LOSS, OR DAMAGE CAUSED OR ALLEGED TO BE CAUSED DIRECTLY OR INDIRECTLY BY THE GOODS INCLUDING, BUT NOT LIMITED TO, ANY INDIRECT, SPECIAL, CONSEQUENTIAL, OR INCIDENTAL DAMAGES RESULTING FROM THE USE OR OPERATION OF THE GOODS OR ANY BREACH OF THIS WARRANTY. NOT WITHSTANDING THE ABOVE LIMITATIONS AND WARRANTIES, MANUFACTURER'S LIABILITY HEREUNDER FOR DAMAGES INCURRED BY PURCHASER OR OTHERS SHALL NOT EXCEED THE PRICE OF THE GOODS.
- 3.04. NO ACTION ARISING OUT OF ANY CLAIMED BREACH OF THIS WARRANTY OR TRANSACTIONS UNDER THIS WARRANTY MAY BE BROUGHT MORE THAN TWO (2) YEARS AFTER THE CAUSE OF ACTION HAS OCCURRED.

4. MISCELLANEOUS.

- 4.01. Proper Venue for any lawsuits arising from or related to this limited warranty shall be only in Guadalupe County, Texas.
- 4.02. Manufacturer may waive compliance with any of the terms of this limited warranty, but no waiver of any terms shall be deemed to be a waiver of any other term.
- 4.03. If any provision of this limited warranty shall violate any applicable law and is held to be unenforceable, then the invalidity of such provision shall not invalidate any other provisions herein.
- 4.04. Applicable law may provide rights and benefits to purchaser in addition to those provided herein.

KEEP FOR YOUR RECORDS

ATTENTION: Purchaser should fill in the blanks below for his reference when buying repair parts and/or for proper machine identification when applying for warranty.

Alamo Industrial Implement Model _____ Serial Number _____

Date Purchased _____ Dealer _____

ATTENTION:
READ YOUR OPERATOR'S MANUAL

ALAMO INDUSTRIAL

An Alamo Group Company
Post Office Drawer 549
Seguin, Texas 78156
830-379-1480





TO THE OWNER/OPERATOR/DEALER

To keep your implement running efficiently and safely, read your manual thoroughly and follow these directions and the Safety Messages in this Manual. The Table of Contents clearly identifies each section where you can easily find the information you need.

The OCCUPATIONAL SAFETY AND HEALTH ACT (1928.51 Subpart C) makes these minimum safety requirements of tractor operators:

REQUIRED OF THE OWNER:

1. Provide a Roll-Over-Protective Structure that meets the requirements of this Standard; and
2. Provide Seatbelts that meet the requirements of this paragraph of this Standard and SAE J4C; and
3. Ensure that each employee uses such Seatbelt while the tractor is moving; and
4. Ensure that each employee tightens the Seatbelt sufficiently to confine the employee to the protected area provided by the ROPS.

REQUIRED OF THE OPERATOR

1. Securely fasten seatbelt if the tractor has a ROPS.
2. Where possible, avoid operating the tractor near ditches, embankments, and holes.
3. Reduce speed when turning, crossing slopes, and on rough, slick, or muddy surfaces.
4. Stay off slopes too steep for safe operation.
5. Watch where you are going - especially at row ends, on roads, and around trees.
6. Do not permit others to ride.
7. Operate the tractor smoothly - no jerky turns, starts, or stops.
8. Hitch only to the drawbar and hitch points recommended by the tractor manufacturer.
9. When the tractor is stopped, set brakes securely and use park lock, if available.

Keep children away from danger all day, every day...

Equip tractors with rollover protection (ROPS) and keep all machinery guards in place...

Please work, drive, play and live each day with care and concern for your safety and that of your family and fellow citizens.

