



SILENT KNIGHT

Model 9500

**Central Station
Receiver**

**Installation and
Operations Manual**

**Part Number 151059 Rev H
Preliminary, 09/06**

Contents

Section 1 System Overview 1-1

1.1	Features	1-1
	Hardware:	1-1
	Software:	1-2
1.2	Optional Accessories	1-2
1.3	Formats Compatible with the 9500	1-3
1.4	9500 Supported SIA Digital I-III Levels	1-4
1.5	How to Use this Manual	1-5
1.6	Terminology	1-5
1.7	What's in the Box	1-6
1.8	How to Contact Silent Knight	1-6

Section 2 Agency Requirements 2-1

2.1	Telephone Requirements	2-1
2.2	FCC Warning	2-1
2.3	UL Requirements	2-1
	2.3.1 Hardware Requirements	2-2
	2.3.2 Operational Requirements	2-2
	2.3.3 Programming Requirements	2-2

Section 3 Installation 3-1

3.1	Environmental Specifications	3-1
3.2	Electrical Specifications	3-1
3.3	Overview	3-2
3.4	Line Card Installation	3-4
3.5	Removing Line Cards	3-5
3.6	Telephone Line Connection	3-6
3.7	Parallel Printer Connection	3-7
	3.7.1 Printer Cable Pin-Outs	3-8
	3.7.2 Com Ports 1 & 2	3-8
	3.7.3 Programmable Remote Alert Output	3-9
3.8	AC Power Cord Connection	3-9
	3.8.1 Using Standard Power Cord	3-9
	3.8.2 Using UL Listed AC Power Connection	3-10
	3.8.3 Switching to a 230 VAC Power Supply	3-12
	3.8.4 How to Verify Earth Ground	3-13
3.9	Battery Connection	3-14
3.10	Automation Computer Connection	3-16
	3.10.1 Computer Port Baud Rate Selection	3-16

3.11	Master/Slave Receiver Linking	3-17
3.11.1	Receiver Linking Cable	3-17
3.11.2	Master/Slave Automation Configuration	3-18
3.11.2.1	Master/Slave Automation Programming	3-18
3.11.3	Master/Slave Printer Configuration	3-19
3.11.3.1	Master/Slave Printer Programming	3-19

Section 4 Operation

4.1	Touchpad Function Buttons	4-1
4.2	Displays	4-3
4.2.1	LED Displays	4-3
4.2.2	LCD Status Display	4-3
4.2.2.1	Adjusting LCD Contrast	4-4
4.2.2.2	LCD Abbreviations	4-4
4.3	Initial System Power Up	4-5
4.4	Log On / Log Off	4-5
4.4.1	Installer Profile	4-5
4.4.2	Operator Profile	4-5
4.4.3	Default User Codes	4-6
4.4.4	How to log on the system.	4-6
4.4.5	How to log off the system.	4-7
4.5	Modes of Operation	4-8
4.5.1	Normal Mode	4-8
4.5.1.1	Manual Operation	4-8
	How to Manually Acknowledge Calls:	4-8
4.5.1.2	Automatic Operation	4-8
4.5.1.3	Log Only	4-8
4.5.2	Program Mode	4-8
4.6	Main Menu	4-9
4.6.1	How to display the Main Menu	4-9
4.6.2	How to Maneuver Through Main Menu	4-10
4.6.3	Call History	4-11
4.6.4	System History	4-11
4.6.5	System Info	4-12
4.6.6	Set Time & Date	4-13
4.6.7	System Restart	4-14
4.6.8	Printer Menu	4-15
4.6.8.1	Print Report	4-17
	How to Print Call History	4-17
	How to Print System History	4-18
	How to Print System Configuration	4-19
	How to Print a Test Page	4-20
4.6.8.2	Edit Event Format	4-20
4.6.8.3	Configure Printer	4-21
4.6.9	Program Menu	4-22
4.6.10	Diagnostics Menu	4-22
4.6.10.1	Phantom Menu	4-23
4.6.10.2	Message Que	4-24
4.6.10.3	Event Log	4-24
4.6.10.4	Format	4-25
4.6.10.5	LC Debug Mode	4-25
4.6.10.6	LC Statistics	4-26

4.6.10.7 Port Status	4-27
4.6.11 PC Connection	4-28
4.7 Listen-In and Hang Up	4-29
4.7.1 Extend (Common) Listen-In Operation	4-29
4.7.2 PBX Operation	4-30
4.8 Testing the System	4-30

Section 5

Programming 5-1

5.1 UL 864 Programming Requirements	5-1
5.2 How to Enter Program Mode	5-1
5.2.1 Programming Fields	5-2
5.2.2 How to Maneuver Around in Program Mode	5-2
5.3 Programming Choices	5-3
5.4 General Options	5-3
5.4.1 Operation Mode	5-4
5.4.1.1 How to Change the Operation Mode	5-5
5.4.2 Display Options	5-6
5.4.2.1 How to Change Language Display	5-8
5.4.2.2 How to Change Time Format Display	5-8
5.4.2.3 How to Change Date Format Display	5-9
5.4.2.4 How to Set/Change Daylight Saving Time	5-9
5.4.2.5 How to Edit ITI Options	5-10
5.4.2.6 How to Edit Format (FMT) Options	5-11
5.4.2.7 How to Set Hold Last Event	5-11
5.4.3 Communications	5-12
5.4.3.1 How to Set Up Port Function	5-14
5.4.3.2 How to set Com Port 1 Parameters	5-15
5.4.3.3 How to Set Com Port 2 Parameters	5-15
5.4.3.4 How to Edit Init String (Par Port)	5-16
To clear an init string:	5-17
5.4.3.5 How to Set Automation Communication	5-17
How to Set the Format	5-17
How Enable or Disable Hex Mode	5-18
How Enable or Disable Heartbeat	5-18
Set Heartbeat Time Period	5-19
Ack Time (Acknowledge Time)	5-19
ITI Options (Only Visible if ITI Gen or ITIComp Formats are Chosen)	5-20
Log Recs (For ITI Formats):	5-21
XID (Extended ID for ITI Panels):	5-21
SupCh (Supervisory Character):	5-21
NoData (No Data Character for Log Record):	5-21
5.4.3.6 How to Configure the On-board Annunciator Outputs	5-22
5.4.3.7 How to Configure the Auxiliary Relay Outputs	5-22
5.4.4 System Options	5-23
5.4.4.1 How to Change Backup Battery Setting	5-24
5.4.4.2 How to Set the Receiver ID Number	5-24
5.4.4.3 How to Configure Output for Bad Data Blocks	5-25

5.4.4.4	How to Set the Normal State of the Auxiliary Relay Contact	5-25
5.4.4.5	Select the Receivers Clock Source	5-26
5.4.5	Message Queue Options	5-26
5.4.5.1	Set the Message Queue Warning On Level	5-27
5.4.5.2	Set the Message Queue Warning Off Level	5-28
5.4.5.3	Set the Event Release Time	5-28
5.5	Line Device Menu	5-29
5.5.1	Add Device	5-30
5.5.2	Edit Line Card	5-31
5.5.2.1	Edit Line Card Menu Options	5-32
5.5.2.2	To Enter the Edit Line Card Option	5-36
5.5.2.3	Handshake Sequence	5-37
	About the Handshake Sequence	5-37
	Change the Handshake Sequence Number	5-38
	Change the Format Group	5-38
	Change the Handshake Duration Time	5-38
	Change the Maximum Handshake Wait Time	5-39
	Change the Acknowledgment Tone Duration Time	5-39
5.5.2.4	Pulse Format	5-39
	Select Which Format a 5-digit Pulse Format will be Received As	5-39
	Select Which Format a 6-digit Pulse Format will be Received As	5-40
	Select the Inter-Digit	5-40
	Set for 2300 and 1400 formats that Require Acknowledges on Even Rounds	5-40
	Set for 3/1 and 4/1 Partially Extended Formats	5-41
5.5.2.5	Line Options	5-41
	How to Set the Line Card for a Direct Line (Dedicated Line):	5-41
	To Change the Number of Rings Follow These Steps:	5-42
	To Change the Ring On Time (9810 only):	5-42
	To Change the Ring Off Time (9810 only):	5-43
	To Change the Country Code (9815 only):	5-44
	To Change the Ring Threshold Voltage:	5-45
	To Change the Phone Line Fault Detection (Sample Rate):	5-45
5.5.2.6	Listen-In	5-46
	To Change the Listen Mode:	5-46
	To Change the PBX String:	5-47
	To Change the Listen-In Timeout:	5-48
	To Edit the Listen-In Accounts Lists:	5-48
	To Add a Listen In Account	5-49
	To Edit a Listen In Account	5-49
	To Clear a Listen In Account	5-49
5.5.2.7	Trap List	5-50
	To Add a Trap Account	5-50
	To Edit a Trap Account	5-50
	To Clear a Trap Account	5-51
5.5.2.8	Misc. Line Opt.	5-51
	To Change the Echo Suppress Setting:	5-52
	How to Set Caller ID	5-52
	To Change the Billing Delay Setting:	5-52
	To Change the Hunt Group:	5-53
	To Change the Ring Options (9815 only)	5-53
	To Change Call Hang Up Settings	5-54
5.5.2.9	Ademco Auto Opt	5-55
5.5.2.10	ITI Options Menu	5-55
	ITI SCode Menu:	5-57
	To Set Date/Time Flag:	5-58
	To Enable or Disable ITI 300 Baud Negotiation:	5-58

Set the Type of Listen-In Used for ITI Controls:	5-58
5.5.2.11 Line Gain Options Menu (9815 only)	5-59
Changing the Transmit and Receive Gain	5-59
Changing the Caller ID (CID) Monitor	5-60
Changing the Caller ID (CID) Gain and On Hook Gain	5-60
Changing the Ringer Impedance	5-61
5.5.3 Copy Devices	5-61
5.5.3.1 To Program the Default Settings Into a Line Card	5-61
5.5.3.2 Copy the Programming of an Existing Line Card to Another	5-62
5.5.4 Clear Device	5-63
To Clear or Delete a Line Card From the Receiver:	5-63
5.5.5 View Device	5-64
5.5.6 Rollins	5-64
5.6 User List	5-65
5.6.1 Adding a User	5-66
5.6.2 Editing a User	5-67
5.6.3 Clearing a User From the Receiver	5-68
5.7 PC Account/Code	5-68

Section 6

Compatible Reporting Formats 6-1

6.1 Formats By Communication Group.	6-1
6.2 Format Numbers Used In Printer Output	6-3
6.3 Using Contact ID Format	6-4

Section 7

Troubleshooting & Maintenance 7-1

7.1 Error Messages	7-1
7.2 Troubleshooting Process	7-5
7.3 Replacing the 9500 Fuse	7-6
7.4 Safe Mode	7-7
7.5 Updating the Receiver Software	7-7

Appendix A

Programming Quick Reference Chart A-1

Index Index-1

Section 1

System Overview

This manual describes installation, operation, and programming of the Model 9500 Central Station Receiver (9500). The 9500 is a dual-line desktop receiver. This section lists features, optional accessories, compatible formats, and SIA options supported. This section also includes conventions used in the manual, terminology relevant to this product, and other information.

1.1 Features

Hardware:

- Supports both 120 and 240 VAC installations at 60 and 50Hz operation.
- External annunciation with auxiliary Form C dry contact relay. (Programmable)
- On-board PZT alert. (Programmable.)
- 1 parallel port and 2 serial ports.
- 2 rear SBUS connectors.
- Modular configuration for easy replacement and repair.
- 4 line LCD Display with 20 characters for each line.
- On-board touchpad for manual operation and programming.
- LEDs to indicate system operations.
- One line card will communicate with all supported formats.
- Supports up to 2 line cards which operate independent of each other.
- Line card parameters are stored on the MCPU for faster removal and replacement.
- Line cards support Caller ID and Caller Name Delivery.
- Line cards are individually programmable for format priority and ring parameters.
- Line cards support direct connect phone line monitoring.
- English or Spanish language display.

Software:

- Programmable display options for time and date information.
- View or print the history information by priority or by call or by event.
- Two user profiles to control user access to the receiver.
- Supports up to 40 users.
- Listen-in and trap accounts support wild card variables. Up to 20 accounts available per line card. (20 for listen-in and 20 for trap accounts.)
- Listen-in selectable for direct, hook flash, or PBX phone system.
- Programmable port configuration for automation, printer and backup support.
- 500 event history buffer.

1.2 Optional Accessories

The following accessories for the 9500 are available from Silent Knight Sales Department unless otherwise indicated. You can contact Silent Knight Sales Department by phone or by mail. The Sales Department’s toll free and local numbers are 800-446-6444 and 763-493-6435. Our mailing address is 7550 Meridian Circle, Maple Grove, MN 55369-4927.

Table 1-1: Optional Accessories for the 9500 Central Station Receiver

Item	SK Model	Description/Comments
Line card	9810	The line card monitors the phone line, detects ring and processes the message from the communicating panel.
Line card	9815	The line card monitors the phone line, detects ring and processes the message from the communicating panel. This is a 2nd generation line card that also supports the selection of USA CRT 21 phone service, ring options, call hang time, and line transmit and receive gain.
Backup battery	6712 See Section 3.9	A 12 VDC 7 AH battery which will provide a minimum 4 hours of backup power during an AC power loss. (See Section 2.3.2 for UL backup power requirements.)
Parallel printer	SK320	The 9500 requires the SK320 parallel printer to generate a hard copy of report history.
Printer cable	Not available from Silent Knight	A standard 25-pin cable used to connect the 9500 to an external parallel printer.
UL Conduit Connector Kit	9512 (See Section 3.8.2 for installation.)	Required to meet UL requirements for NFPA 72 Central Station Service.
Automation Software	SK9540W	Alarm center receiver software for a single user that supports up to 250 accounts. For Windows® 98 (2nd Edition).
	SK9541W	Alarm center receiver software for a single user that supports an unlimited number of accounts.

1.3 Formats Compatible with the 9500

The 9500 is compatible with all Silent Knight UL listed communicators.

Table 1-2 shows the formats that the 9500 can decode and the handshake frequency groups which accommodate that format (see Section 5.5 for line card programming). Each line card can decode every format listed below. Setting the handshake order only prioritizes the type of communication done by each line card. Section 6 of this manual describes the formats in greater detail.

Table 1-2: Formats compatible with the 9500

Format Name	Handshake
BFSK	1400 or 2300 Hz
SK FSK, FSK 0, FSK 80	1400 or 2300 Hz
SK FSK 1, FSK 1, FSK 81	1400 or 2300 Hz
FSK II, FSK 86	1400 Hz
SK 4+2	1400 Hz
SK 3+1/3+1 Extended	1400 or 2300 Hz
Sescoa 3+1/Franklin 3+1	2300 Hz
Radionics 3+1 Checksum	1400 or 2300 Hz
4+1 Extended	1400 or 2300 Hz
FBI 4+3+1	1400 or 2300 Hz
SX-III, SX-IVA	2225 Hz
SX-IVB	2225 Hz
ITI SX-V	2225 Hz
ITI Commander	2225 Hz
ITI RF Commander, Harbor Gard	2225 Hz
ITI Commander 2000, LifeGard	2225 Hz
ITI CareTaker+, SecurityPro 4000	2225 Hz
ITI UltraGard	2225 Hz
SIA DCS	2225 Hz
SIA 2000 (pending approval)	2225 Hz
Ademco Contact ID	1400 and 2300 Hz
Ademco Super Fast	1400 and 2300 Hz
Acron Touch Tone	1400 and 2300 Hz
Ademco Express	1400 and 2300 Hz
DTMF 4+2	1400 and 2300 Hz
Westec	Westec
Modem II	Modem II
Modem IIe	Modem IIe

1.4 9500 Supported SIA Digital I-III Levels

Table 1-3 compares the 9500 to SIA Digital Compatibility Levels I, II, and III and indicates which of them we comply with.

Table 1-3: 9500 and SIA Levels I-III comparison

		9500	Function/Capability	Transmitter	Receiver	
Level I	Level II	✓	Support Tonal Acknowledgments	required	required	
		✓	Support N blocks with Zone Numbers Only	required	required	
		✓	Support single Account Block per Call	required	required	
		✓	Support O Blocks	(optional)	required	
		✓	Support X Blocks	(optional)	required	
		✓	Support 300 Baud (Fast)	(optional)	required	
	Level III			Support Configuration Block	required	required
				Support Data Acknowledgments	required	required
		✓		Support Modifier codes <i>id</i> , <i>da</i> and <i>ti</i> .	(optional)	required
		✓		Support Multiple Account Blocks per Call	(optional)	required
		✓		Support E Blocks	(optional)	required
		✓		Support Data Codes with Units Numbers	(optional)	required
				Support RECEIVER call out and Access Passcode	required	required
				Support Reverse Channel C Blocks	required	required
				Support Reverse Channel P Blocks	required	(optional)
				Support Reverse Channel A Blocks	(optional)	required
				Support Dynamic block and Group Sizes	(optional)	required
		✓		Support Listen-in	(optional)	required
✓		Support A Blocks to RECEIVER	(optional)	required		
		Support V-Channel communication	(optional)	(optional)		

1.5 How to Use this Manual

This manual contains information on how to install, operate and program the 9500. Silent Knight strongly suggests that the manual be reviewed in its entirety to become familiar with procedures and parameters of the product. Once you are familiar with the product, the manual can be used as a reference document.

The manual uses the following conventions:

- A small graphic of each touchpad button is used to represent which touchpad key is to be pressed for a given operation. For example, an up-arrow would be shown as: 
- LCD display This typeface represents messages that appear on the LCD.
- **2225Hz** This typeface represents an editable field that appears on the LCD.
- Pages of the manual are numbered by section. For example, a page numbered as “5-1” is Page 1 of Section 5.
- When this manual refers to **default settings**, it means programmable options set at the factory. Any programming after the receiver is powered up will change these setting.

1.6 Terminology

This section lists terminology that is specific to this product and their meaning.

Term	Meaning
Communication Group	Silent Knight has separated the different types of communication by handshake type. These handshake types can be assigned in a numbered order. (See Section 6 for more details.)
Listen-in	Listen-in is the ability to listen in to what is happening real-time from the central station to a remote location. This can help the central station operator determine if he or she should dispatch for a particular alarm situation.
PZT	PZT is an abbreviation for a piezo alert sounder.
PIN	An abbreviation for Personal Identification Number. PINs are used to log in and out of the receiver.
SBUS	Serial Bus interface to connect a 9500 to 9810/9815 Line cards and the LCD display.
MCPU	Master Central Processing Unit.
Main Menu	The main menu will be displayed as either <Installer Menu> or <Operator Menu> . However, this manual will refer to them as the main menu.
ACK	Stands for acknowledgment.
NACK	Stands for no acknowledgment.

1.7 What's in the Box

This section contains a list of the parts that are shipped with the 9500 and a brief description of their intended use.

Item	Quantity	P/N	Description
Battery/Alert Programmable Relay Wiring Harness	1	130393	Wiring harness used to connect the 9500 to a backup battery. It also provides a normally open or normally closed output for an alert sounder.
9500 Installation/Operation Manual	1	151059	A manual covering installation and operation information related to the 9500.
Central Station Receiver	1	9500	The central station receiver assembly.
Line Card	1	9810/9815	Line card for land lines.
Strain Relief Tie Wrap	1	120101	Tie wrap used as a strain relief on the phone cord. See Figure 3-3 for location of strain relief tabs.
Telephone Cord	1	130071	A 7 foot long telephone cable with RJ-11 connectors.
Power Cable	1	119229	AC power cable used to connect the 9500 to an AC wall plug.

1.8 How to Contact Silent Knight

If you have a question or encounter a problem not covered in this manual, contact Silent Knight Technical Support at 800-328-0103 (or 612-493-6455). To order parts, contact Silent Knight Sales at 800-446-6444 (or 612-493-6435).

Section 2

Agency Requirements

2.1 Telephone Requirements

If requested by the telephone company, the following information must be provided before connecting this device to the phone lines:

- | | |
|-------------------------------------------------------------|-------------------|
| A. Manufacturer: | Silent Knight |
| B. Model Number: | 9500 |
| C. FCC Registration Number: | AC6USA-31519-AL-E |
| D. Type of jack (to be installed by the telephone company): | RJ11X |
| Ringer equivalence: | 0.1B |

This device may not be connected directly to coin telephones or party line services.

This device cannot be adjusted or repaired in the field. In case of trouble with the device, notify the installing company or Silent Knight for an RMA and then return it to:

Silent Knight Security Systems
7550 Meridian Circle
Maple Grove, MN 55369-4927
800-328-0103 or 763-493-6455

The telephone company may make changes in its facilities, equipment, or procedures that could affect the operation of the equipment. If this happens, the telephone company will provide advance notice to allow you to make the necessary modifications to maintain uninterrupted service.

2.2 FCC Warning

This device complies with FCC Rules Part 68.

This device has been verified to comply with FCC Rules Part 15. Operation is subject to the two following conditions: (1) This device may not cause radio interference, and (2) This device must accept any interference received including interference that may cause undesired operation.

2.3 UL Requirements

Follow the procedures outlined in the sections below for listing as an NFPA 72 Central Station Service installation. The 9500 is also suitable for household and commercial burglary service.

Note: Installation regulations are subject to the jurisdiction of the local authority.

2.3.1 Hardware Requirements

1. A second 9500 must be installed as a backup in case the primary 9500 fails. The backup system must be able to take over within 30 seconds. (Note: This requirement does not apply to burglary-only installations.)
2. AC power must run in conduit and be attached to the 9512 conduit connector kit. See Section 3.8.2.

2.3.2 Operational Requirements

1. The transmitters reporting to the 9500 must be UL Listed DACTs (digital alarm communicator transmitters).
2. The central station must provide a minimum of 24 hours of backup power within 30 seconds of a AC power loss. The backup must either be in the form of a UL listed 1481 UPS or electrical generator. Listed for fire protective signaling.
3. If the 9500 is not automated, the central station operator must check for the 24 hour test signals from the communicators. (Note: This requirement does not apply to burglary-only installations.)
4. The connection between the 9500 and the UL listed computer (Computer must be suitable for use as a fire protective signaling computer.) should be according to the pin configuration for Com port 1 as shown in Section 3.10, Figure 3-14 and Figure 3-15, of this manual.
5. If a computer is used, the computer and its accessories must be installed in the same room as the receiver.
6. The listen-in feature is intended for burglary applications only and may not be used if the receiver will be accepting commercial fire signals.

2.3.3 Programming Requirements

In a UL listed installation, the Model 9500 receiver must be programmed according to the following procedure:

- Do NOT use the alarm output relay in UL installations.
- Each log-on code must have at least four digits.

Section 3

Installation

This section contains information necessary to install a 9500 Central Station Receiver.

IMPORTANT

Do not connect power to the system until you have read these instructions carefully.

3.1 Environmental Specifications

- Intended for indoor use in dry locations only
- Non-corrosive environment
- Temperature range: 32° to 120° F
- Humidity: 10%-93% at 30°C (86°F) noncondensing

3.2 Electrical Specifications

Line Voltage:		120VAC ± 10%	60Hz, 100VA
		240VAC ± 10%	50Hz, 100VA
Fuse:		2.5A Slow Blow	
Backup Battery Connection: Note: A 12 VDC battery does not provide standby time required by UL and NFPA standards. A UPS (listed for fire protective signaling use) must be utilized when standby power is required. See 5.4.4 for details on backup battery configuration.	Input	12 VDC Nominal	3 Amp Max.
	Output	13.65 VDC	1 Amp charging current
Auxiliary Relay (Programmable):		2.5 Amp @ 24 VAC/VDC(Inductive), 0 Hz 5 Amp @ 24 VAC/VDC(Resistive), 0 Hz	

3.3 Overview

The 9500 is assembled at the factory. One line card is shipped with the 9500 receiver. Follow the procedures described in Section 3.4 to install additional line cards.

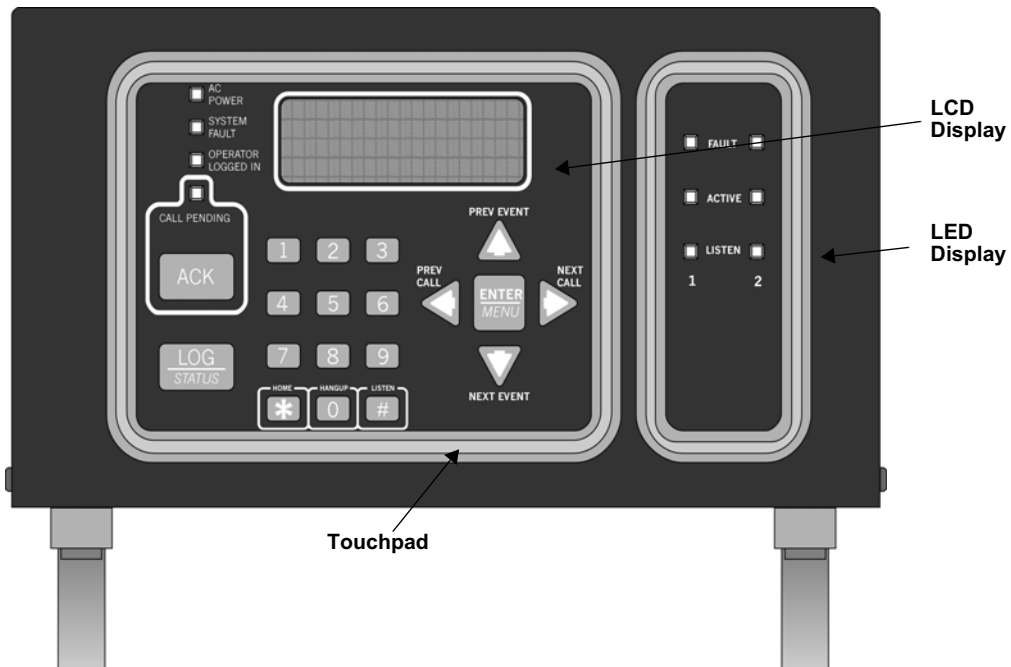

Figure 3-1 Model 9500 Front View

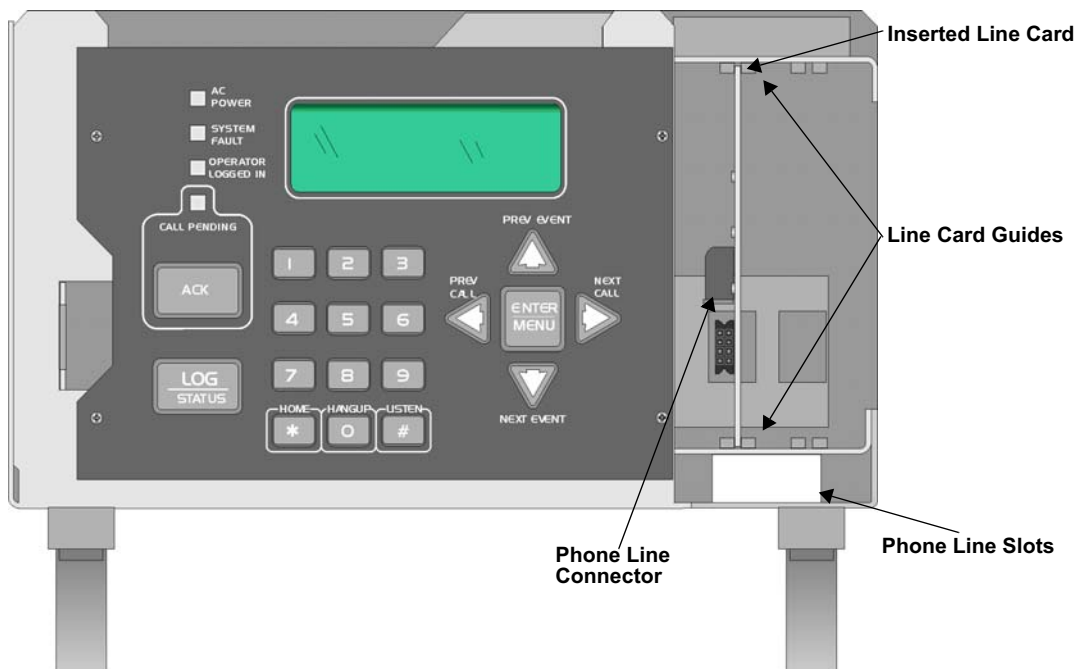

Figure 3-2 Model 9500 Front View Without the Cover On

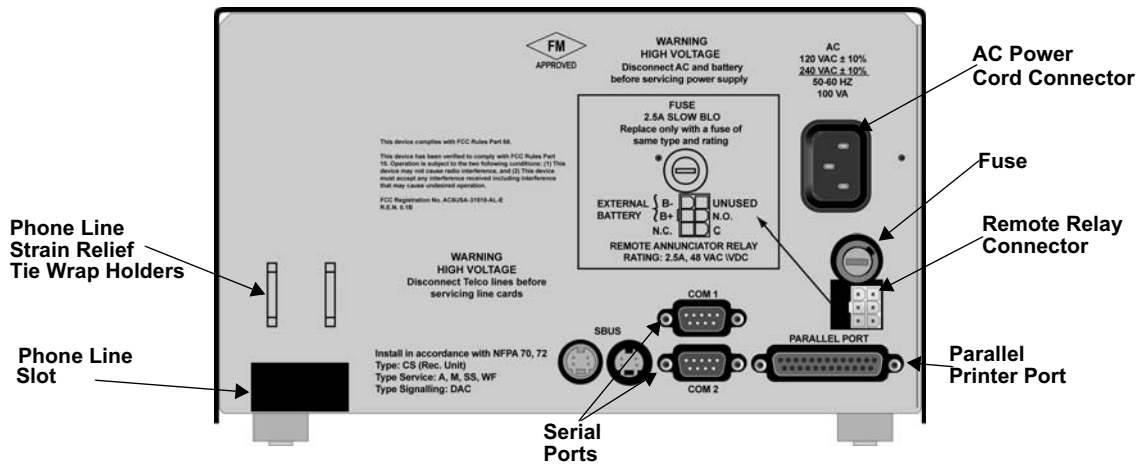

Figure 3-3 Model 9500 Rear View

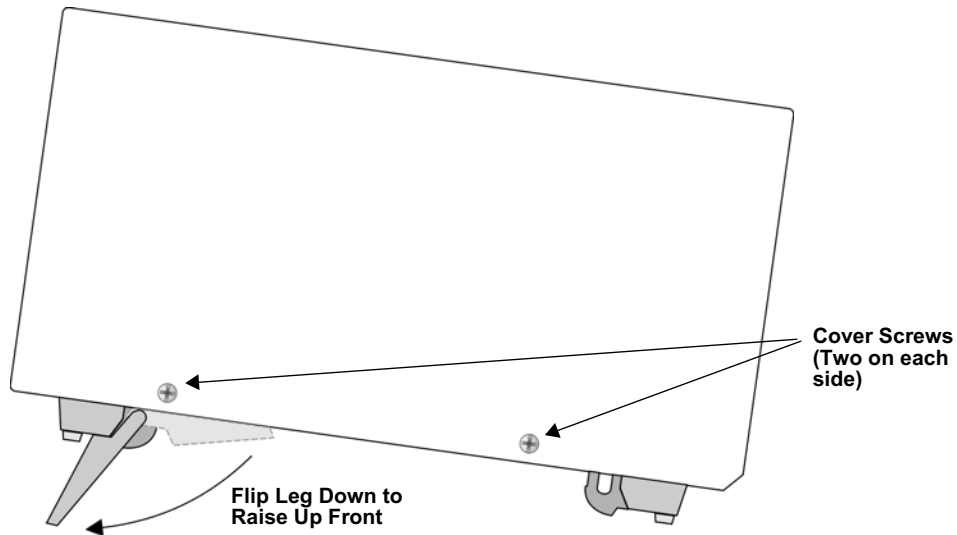

Figure 3-4 Side View

3.4 Line Card Installation

Caution

To reduce the risk of electrical shock and damage to the receiver, follow the steps below in the order listed.

This section describes how to install the 9810 and 9815 line cards.

1. Remove the 9500 cover by unscrewing the four cover screws located on the both sides of the receiver. (See Figure 3-4 for the cover locations.)
2. Remove power by disconnecting the AC power cable (see Section 3.8.1 or 3.8.2 depending on the type of AC connection used) and backup battery (if used).
3. When the cover removed, you will see that there are 2 slots for line cards. The receiver recognizes each slot by number 1 and 2 (slot one is closest to the keypad and display). It is not necessary to put line cards in numbered order because the receiver continually polls each slot to see if existing line cards are functioning and if it is still in its slot. The receiver also looks to see if a new line card has been added. Figure 3-5 shows how to position each line card for installation.

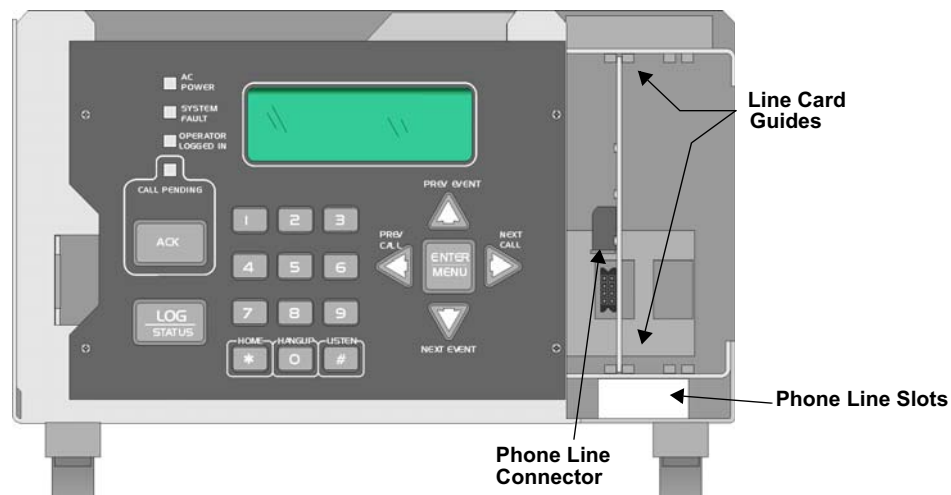

Figure 3-5 Line Card Locations

4. Position the line card as shown in Figure 3-6.



Figure 3-6 Line Card Position and Components

5. Carefully slide the line card into its guides (both top and bottom) until it fits into its connector at the back of the receiver. Gently push the line card as far into the connector as you can. The line card is now in place. See Figure 3-5.
6. Connect telephone line. (See Section 3.6 for telephone line installation.)

Note: Use the tie wrap (P/N 120101 provided with each line card) on the tie wrap holder to add strain relief to the telephone lines. See Figure 3-3.

7. Return AC power and back up battery power (if used).
8. Replace the 9500's cover and screw in the cover screws to hold the cover in place. If you are simply replacing a line card with another card of the same type and are using the same format settings, your installation is now complete. If not continue to the next step.
9. Enter programming mode to select the appropriate handshake configuration. (Go to Section 5.5 for programming procedure.)

3.5 Removing Line Cards

If you need to remove a 9810 or 9815 line card:

1. Remove the 9500's cover by unscrewing the four cover screws located on both the sides of the receiver. (See Figure 3-4 for front plate retaining screw locations.)
2. Remove power by disconnecting the AC power cable (see Section 3.8.1 or 3.8.2 depending on the type of AC connection used) and backup battery (if used).

With the cover removed you will see that there are 2 slots for line cards.

3. Locate the line card that you wish to remove.
4. Unplug the telephone line. (See Figure 3-5 and Figure 3-6.)
5. From the front side of the receiver pull the line card straight back. This will pull the card free from the connector at the rear of the receiver.
6. When the line card is free, slide it carefully out of the receiver.

Note: If replacing a line card with a new one see Section 3.4 to install the new line card.

7. Return AC power and back up battery power (if used).
8. Replace the 9500's cover and replace the cover screws.
9. Enter programming mode to clear the line card from the system. (See Section 5.5 for programming procedure.)

3.6 Telephone Line Connection

See Figure 3-3 for the location of the phone line inputs. Connections to the 9810 phone jacks are made with a standard 7-foot phone cord (provided with each 9810 and 9815 line card).

Use the following procedure to connect phone lines to 9810 and 9815 line cards:

1. Remove the cover of the 9500 receiver by loosening cover screws. (See Figure 3-4 for cover screws locations.)
2. From the back side of the receiver insert the telephone line through the corresponding slot for the desired line card. (See Figure 3-5 and Figure 3-6 for phone line slot locations.)
3. Gently push it all the way through to the front side of the receiver.
4. Plug the RJ-11 phone connector into the connector on the line card. (See Figure 3-5 and Figure 3-6.)

Note: Use the tie wrap (P/N 120101 provided with each line card) on the tie wrap holder to add strain relief to the telephone lines. See Figure 3-3.

5. Replace the cover of the 9500 receiver. (See Figure 3-4 for cover screws locations.)

3.7 Parallel Printer Connection

The 9500 connects to the model SK320 printer for UL applications. To connect the SK320 to the 9500 follow these steps:

1. Connect the standard parallel printer cable to the parallel printer port on the back of the 9500. (See Figure 3-7.)

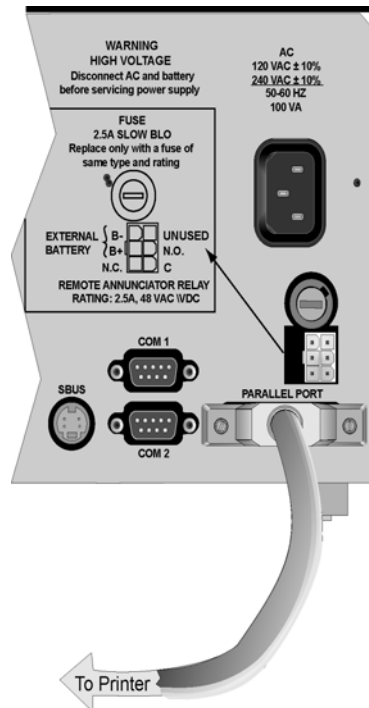

Figure 3-7 Parallel Printer Cable Connection to 9500

2. Connect the other end to the SK320 parallel printer port.

Note: Make sure that printer power is turned off.

3. Turn the printer power “on”.

3.7.1 Printer Cable Pin-Outs

25 pin printer cables are a standard items at most electronic stores, however, if you create your own cable, use the pin description in Table 3-1.

Table 3-1: External Printer Cable Pin Description

9500 Pin #	Signal	Direction	Description
1	Data Strobe (Low)	Out	A low strobe pulse to read data in the pulse width is greater than 0.5 microseconds.
2	Data Bit 1	Out	These signals represent information of the first to eighth bits of parallel data. Each signal is at high level when the data is logic 1 and low when it is logic 0.
3	Data Bit 2	Out	
4	Data Bit 3	Out	
5	Data Bit 4	Out	
6	Data Bit 5	Out	
7	Data Bit 6	Out	
8	Data Bit 7	Out	
9	Data Bit 8	Out	
10	/AckNlg	In	A low pulse from the printer signals the control that the printer is ready for additional data.
11	Busy	In	A high level indicates that the printer is busy.
12	Paper Empty	In	A high level indicates that the printer is out of paper.
13	Select	In	A low level indicates the printer is offline or in an error condition.
14	Not used	-	-
15	Not used	-	-
16	Logic ground	-	Logic ground for printer
17	Not used	-	-
18 to 25	Logic Ground	-	Ground return for data lines.

3.7.2 Com Ports 1 & 2

Com ports one and two are serial communication ports that (through a null modem cable) can be used to communicate to other serial communication devices. Com port one is the only serial communications port that can be used with the automation computer (see Section 3.10). A standard null modem cable can be used to connect com port 1 or 2 to another serial device such as a printer or a PC. Figure 3-14 and Figure 3-15 shown the pin-outs for a null modem cable. See Section 5.4.3 to configure the Com Port 1 and Com Port 2.

3.7.3 Programmable Remote Alert Output

1. Plug the Relay wiring harness onto the connector on the back of the 9500. (See Figure 3-8.)

Note: The remote alert output is a form C relay with a normally open or a normally closed wire.

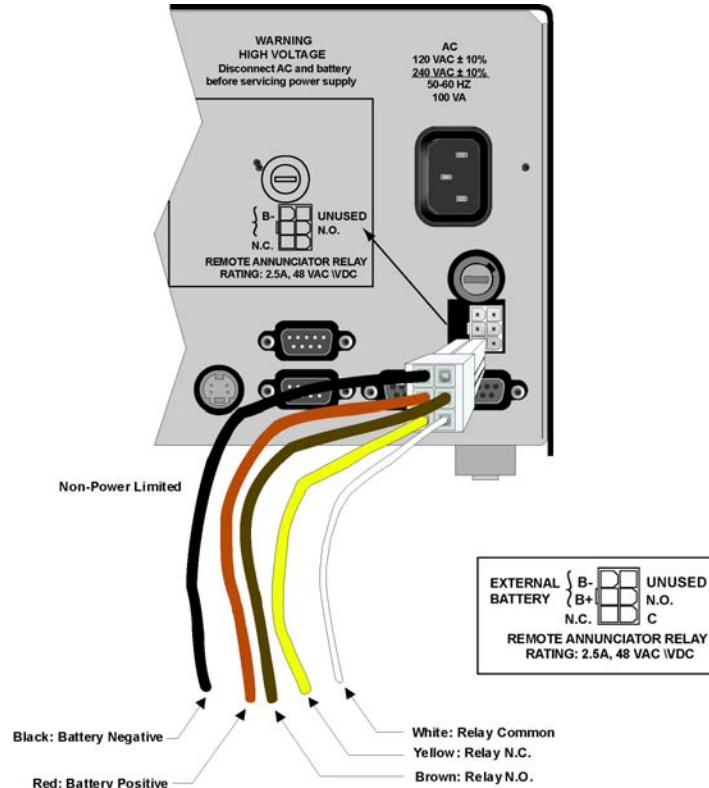

Figure 3-8 9500 Remote Alert Output/External Backup Battery Connection

2. Connect the white wire to common.
 3. Use the Yellow wire for a normally closed circuit
- Or
- Use the Brown wire for a normally open circuit.

3.8 AC Power Cord Connection

3.8.1 Using Standard Power Cord

1. Connect the appropriate end of the power cord into its receptacle on the back of the 9500.
2. Plug the three-pronged end of the power cord into a 120 VAC 60 Hz outlet (three-prong type only). The outlet should be unswitched, so that power remains on 24 hours a day. The outlet must also be earth grounded. Follow the directions in Section 3.8.4 if you need to measure for proper earth grounding.

3.8.2 Using UL Listed AC Power Connection

To meet UL requirements for Central Station Service, the AC power must be run in conduit into a single gang junction box. Use UL listed Model 9512 Conduit Connector Kit to attach conduit to the receiver.

Table 3-2 lists the items contained in the 9512 Conduit Connector Kit.

Table 3-2: 9512 Conduit Connector Kit

Item	Quantity
Single Gang Electrical Box	1
Receiver Chassis Mounting Screws	2
AC Pigtailed Power Cable	1

Follow these steps to properly connect the AC and the 9512 connector kit:

Note: It may be necessary to have a licensed electrician make the AC connections.

1. Run AC wire in conduit to the receiver.

Warning! *To avoid electrical shock, make sure that AC power on the this circuit is turned off.*

2. Feed AC wire through the conduit opening in the back (or the opening that best fits your conduit configuration) of the single gang electrical box.

3. Connect the AC wire to the 9500 AC pigtailed power cable. See Figure 3-9.

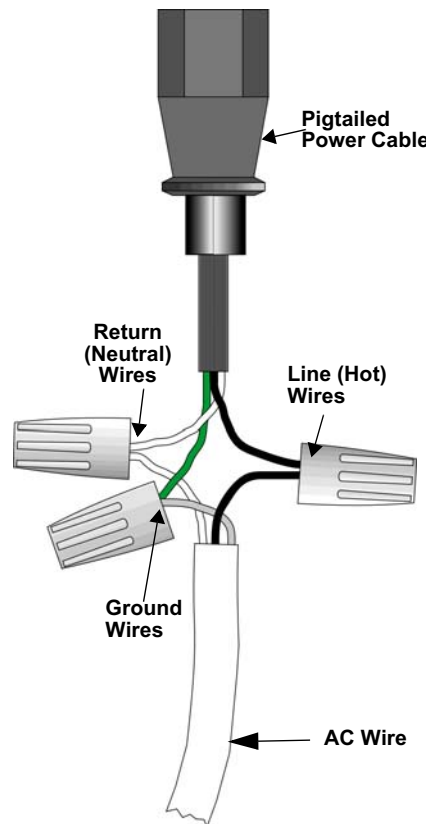
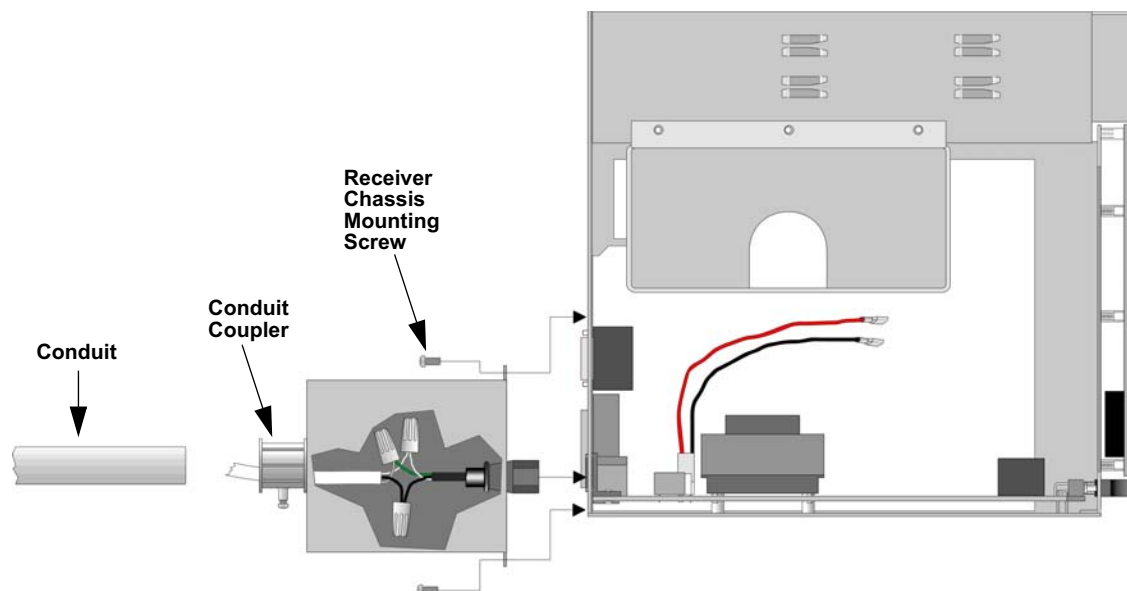

Figure 3-9 AC Wire Connection To 9500 Pigtail

4. Plug the wired pigtail into the AC receptacle on the back of the 9500. See Figure 3-3.
5. Secure the electrical box to the back of the 9500 with the two chassis mounting screws.



6. Connect the conduit to the electrical box using the appropriate conduit coupler.
7. Turn on AC power to this circuit.

3.8.3 Switching to a 230 VAC Power Supply

1. Remove the cover by unscrewing the four cover screws. (See Figure 3-4 for locations of cover screws.)
2. Disconnect AC power cable. See Sections 3.8.1 or 3.8.2 depending on the type of AC connection used in this installation.
3. Disconnect the backup battery. (See Figure 3-13.)
4. Switch the power supply select switch to the up position. The switch will show 230VAC. (See Figure 3-10 and Figure 3-12.)

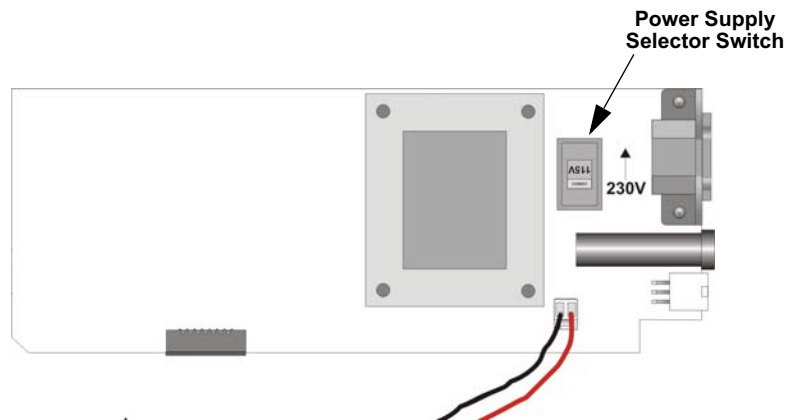

Figure 3-10 Side View of Power Supply Assembly

5. Reconnect the AC power cable.

Note: Make sure to plug the AC power cable into a grounded 240VAC outlet.

6. Reconnect the back-up battery. (See Figure 3-13.)
7. Replace the cover by screwing in the four cover screws. (See Figure 3-4.)

3.8.4 How to Verify Earth Ground

To verify earth ground at the AC outlet the 9500 receiver is powered from, use the following steps:

1. Measure the AC voltage between the center ground post and each side of the outlet (see A & B in Figure 3-11). You should read approximately 120 VAC (or 240VAC for 240VAC circuits) at measurement point B and nominal VAC at measurement point A.

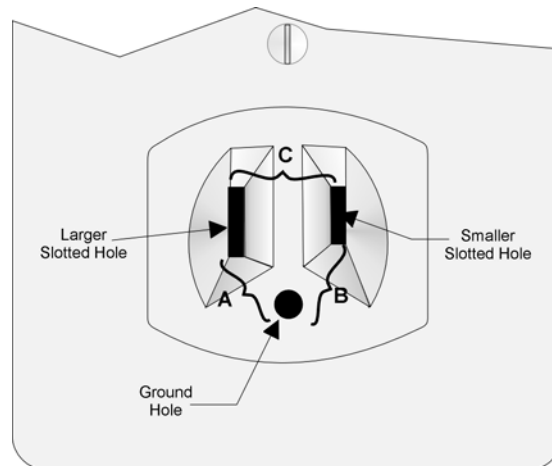

Figure 3-11 Outlet Voltage Measurement Points

2. Measure the voltage between the two slotted holes. It should be equal to the voltage reading at measurement point B. (See Figure 3-11.)

If these voltages are not equal, the outlet does not have a proper earth ground.

3. Ground the outlet by running a wire (18 gauge or higher) to a good earth ground.

The wire should be of equal or greater diameter to the wires used to feed the outlet. It may be necessary to have a licensed electrician ground the outlet.

3.9 Battery Connection

To install the 6712 backup battery follow these steps:

Note: The 6712 (12VDC 7ah battery) will provide a minimum of 4 hours of battery backup power. (See 3.8.4 for UL requirements.)

1. Place the 6712 backup battery into the battery bucket (See Figure 3-13).

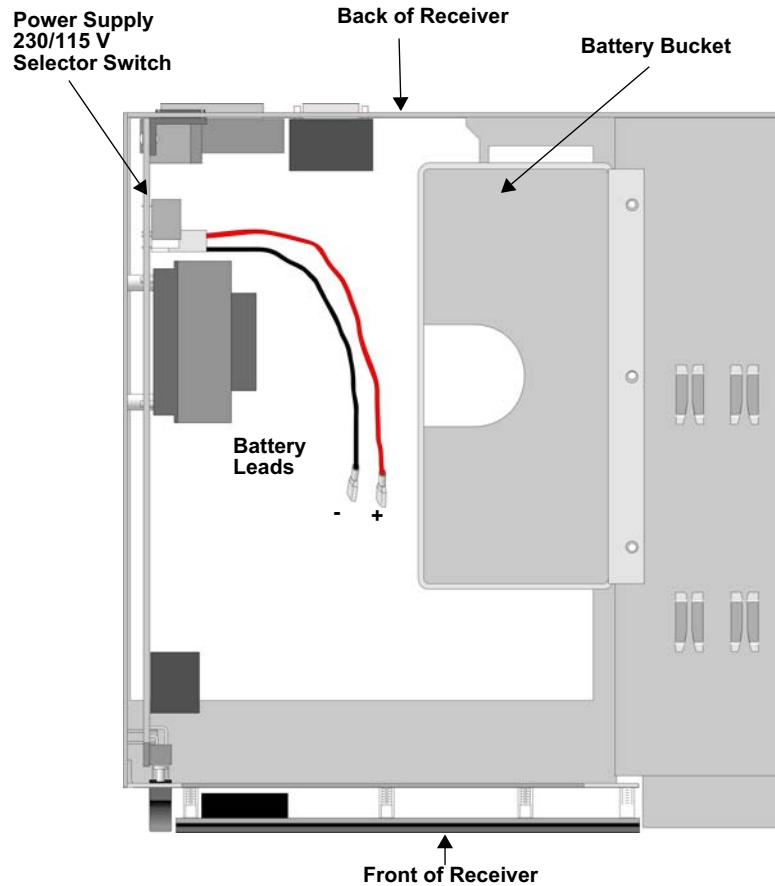

Figure 3-12 Top View of Receiver

2. Connect the RED terminal to the positive (+) side of the battery.

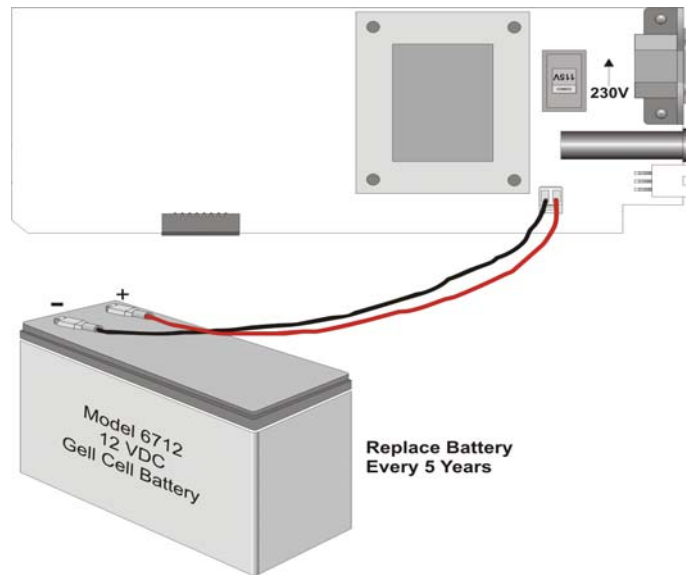

Figure 3-13 Battery Connections

3. Connect the BLACK terminal to the negative (-) side of the battery.

Note: Incorrect polarity can damage the battery and the 9500.

3.10 Automation Computer Connection

An automation computer can be connected to Com Port 1 on the 9500 receiver. Com Port 1 is a 9-pin DTE port. Refer to *Automation Communication Protocols Reference Guide* (PN 151393) for details on automation communication protocols. The diagrams below describe some of the cable options.

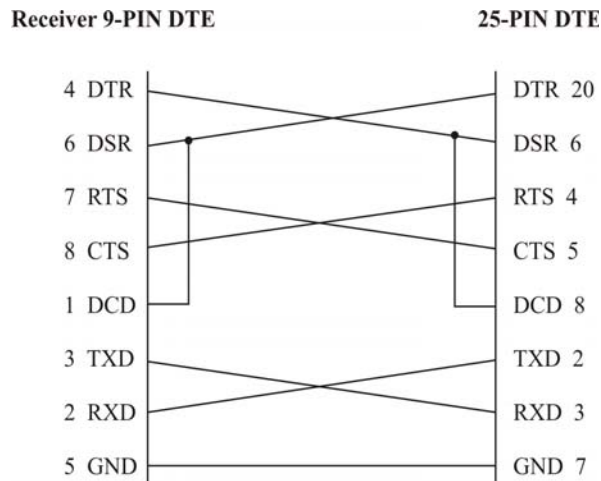

Figure 3-14 25-Pin Null Modem Cable Connection

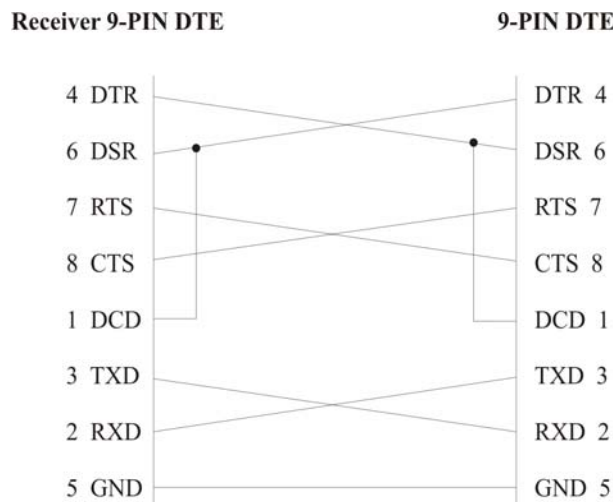

Figure 3-15 9-Pin Null Modem Cable Connection

3.10.1 Computer Port Baud Rate Selection

The computer port baud rate is selectable from 110 to 19200 (See Section 5 *Programming*).

3.11 Master/Slave Receiver Linking

The SBUS connector on the receiver can be used to link up to eight receivers outputting to one automation computer and/or printer, depending on the Master/Slave configuration. The Master/Slave configuration consists of one receiver being programmed as a Master and the remaining receivers programmed as Slave receivers. The linking feature can decrease the number of serial ports required on the automation computer and/or the quantity of printers used for event logging.

There are two types of Master/Slave linking that can be used, the Master/Slave Printer configuration, and the Master/Slave Automation configuration. If a receiver is programmed as a Master Printer, then the slave receivers must be programmed as Slave Printer. And if a master receiver is programmed as Master Automation, the slave receivers must be programmed as Slave Automation receivers. See Section 5.4.4.2 for information on programming receivers for Master/Slave mode of operation.

The receivers are linked using a standard 4-wire RJ-11 phone cable.

3.11.1 Receiver Linking Cable

Use a 4-wire RJ-11 phone cable as shown in Figure 3-16 to connect the receivers together for receiver linking.

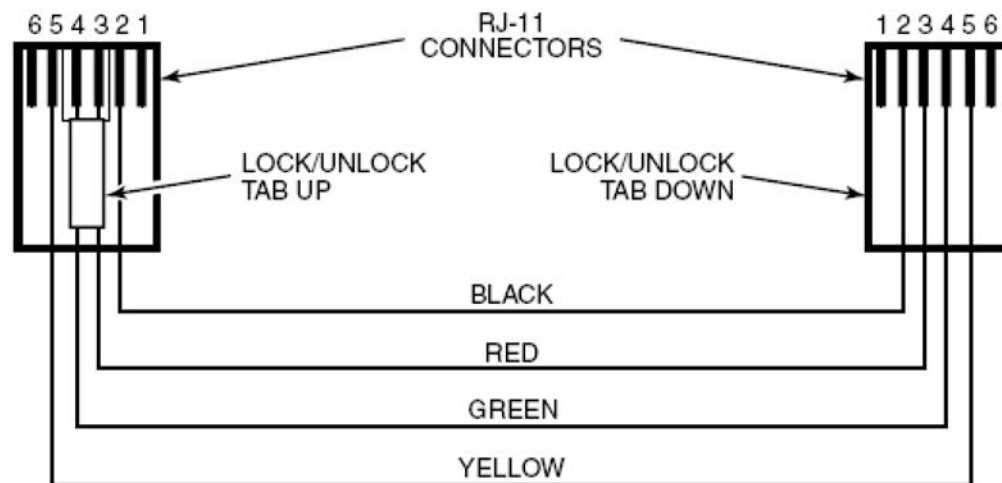
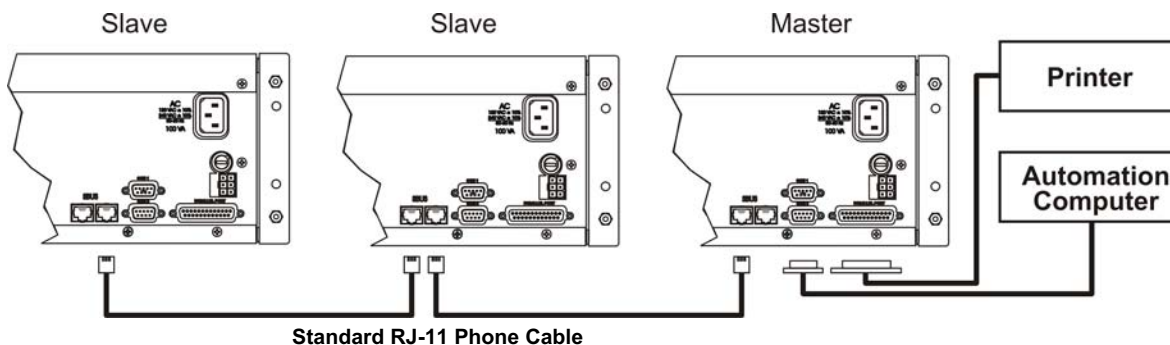

Figure 3-16 Receiver Linking Using an RJ-11 Cable.

3.11.2 Master/Slave Automation Configuration

Figure 3-17 illustrates the Master/Slave Automation configuration.



Limit to One Master and Seven Slave Receivers

Figure 3-17 Master/Slave Automation Configuration

3.11.2.1 Master/Slave Automation Programming

You will program the Master Receiver first, then program each Slave Receiver.

To perform Master/Slave Automation Programming:

1. Power up the Master Receiver and allow the Line Cards to be initialized.
2. From the “Installer/Program Menu/General Options” display, select “1 Operation Mode” and configure for “Automatic.”
3. From the “3 Communications” display, select “1 Port Functions” and configure COM1 for “Automation” and parallel port for “Auto Bkp Prn.”
4. From “4 System Options” select “MstrAuto” and set appropriate “Rcvr ID.”
5. From “6 Slave List” enter a unique Slave number for each slave receiver.
6. Exit the programming mode and cycle power on the Master Receiver for the new settings to take effect. You are done programming the Master Receiver.
7. Power up the Slave Receiver and allow the Line Cards to be initialized.
8. From the “Installer/Program Menu/General Options” display, select “1 Operation Mode” and configure for “Automatic.”
9. From “4 System Options” select verify “SlvAuto” setting and set appropriate “Rcvr ID.” matching the number programmed in the Master Receiver.
10. Exit the programming mode.
11. Repeat steps 7 through 10 on any other Slave Receiver used.
12. When all receivers have been programmed, connect a 4-pin RJ-11 cable from the Master Receiver to the first Slave Receiver and then connect a second RJ-11 cable from the first Slave Receiver to the second Slave Receiver. Connect the remaining slave receivers using the same pattern as described for previous receivers.

3.11.3 Master/Slave Printer Configuration

Figure 3-18 illustrates the Master/Slave Printer configuration.

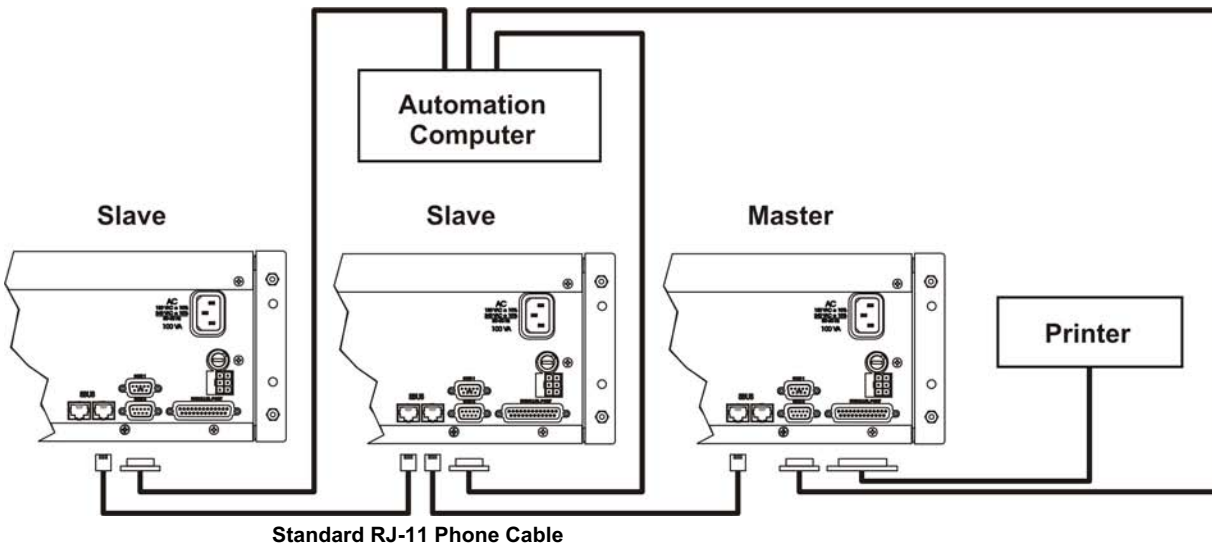

Limit to One Master and Seven Slaves Receivers

Figure 3-18 Master/Slave Printer Configuration

3.11.3.1 Master/Slave Printer Programming

Before attempting to program the master/slave printer, verify that all SBUS connections have been made as described in 3.11.3. You will program the master receiver first, then program each slave receiver.

To program the receivers for master/slave printer:

1. Power up the Master Receiver and allow the Line Cards to be initialized.
2. From the “Installer/Program Menu/General Options” display, select “1 Operation Mode” and configure for “Automatic.”
3. From the “3 Communications” display, select “1 Port Functions” and configure COM1 for “Automation” and parallel port for “Auto Bkp Prn.”
4. From “4 System Options” select “MstrPrn” and set appropriate “Rcvr ID.”
5. From “6 Slave List” enter a unique Slave number for each slave receiver.
6. Exit the programming mode and cycle power on the Master Receiver for the new settings to take effect. You are done programming the Master Receiver.
7. Power up the Slave Receiver and allow the Line Cards to be initialized.
8. From the “Installer/Program Menu/General Options” display, select “1 Operation Mode” and configure for “Automatic.”
9. From the “3 Communications” display, select “1 Port Functions” and configure COM1 for “Automation.”

10. From “4 System Options” select verify “SlvPrn” setting and set appropriate “Rcvr ID.” matching the number programmed in the Master Receiver.
11. Exit the programming mode.
12. Repeat steps 7 through 11 for each additional Slave Receiver used.

Section 4

Operation

This section covers information on how to operate the 9500 Central Station Receiver.

4.1 Touchpad Function Buttons

The front panel of the 9500 has a touchpad, an LCD display, and LED indicators. (See Figure 4-1.)

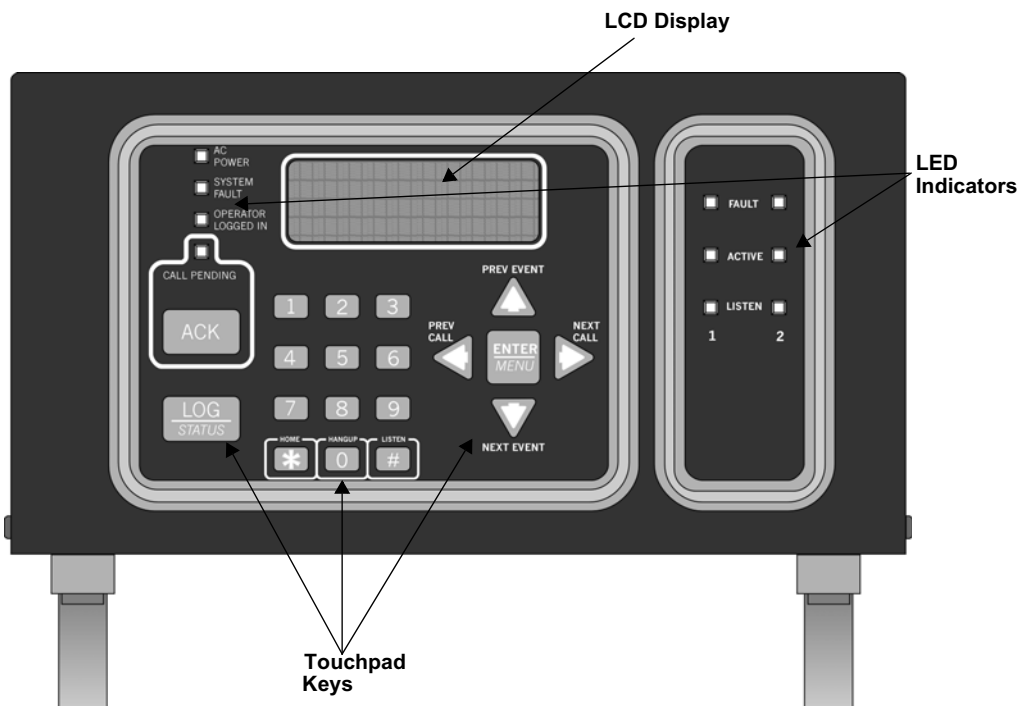













Figure 4-1 Model 9500 Front Panel

The touchpad on the 9500 Receiver is used in all operating modes (normal and programming mode).

Table 4-1 displays each touchpad key and describes its function in normal and programming mode.

Table 4-1: Functions of Touchpad Buttons

Key	Name	Operating Modes	
		Normal	Programming
	Up Arrow	Display previous event.	Go back to previous choice or character.
	Down Arrow	Display next event.	Move to next choice or character.
	Left Arrow	Display previous call.	Exit the current menu. Move to previous programming field.
	Right Arrow	Display next call.	Select menu item indicated by equal sign (see Figure 4-4). Move to next programming field.
	Enter/Menu Button	Bring up Main Menu.	Select menu item indicated by equal sign (see Figure 4-4). Enter chosen parameter.
	Acknowledge Button	Manually Acknowledge a call or event. (Used only if receiver is in manual mode.)	Used in log mode to acknowledge and silence system troubles.
	Log Button	Pressed to log on or off the system. Pressed to view system status messages.	N/A
	Digit Keys	Used to enter numeric inputs.	Numeric input, option selection.
	Star or Home Key	Will return display to the oldest unacknowledged event.	Enters a * Character when programming in an “Edit” field. See Table 5-1 for <i>Types of Programming Fields</i> descriptions.
	0 or Hangup key	In manual mode the 0/hangup key is used to hangup line card when the listen feature was activated, or to end a runaway call from a panel.	Used to enter numeric inputs.
	Pound Key or Listen Key	In manual mode this key is used to initiate the listen in feature.	Enters a # Character when programming in an “Edit” field. See Table 5-1 for <i>Types of Programming Fields</i> descriptions.

4.2 Displays

This section describes the two types of displays that the 9500 uses.

4.2.1 LED Displays

Table 4-2: LED Description

LED		Meaning		
		On	Off	Flashing
Touchpad LEDs	AC Power	AC power is on.	No AC or DC power to the Receiver	No AC power and the system is operating on the backup battery.
	System Fault	A fault condition exists that has been acknowledged but not cleared.	The system is operating normally.	A fault condition exists that has not been acknowledged.
	Operator Logged In	An operator is logged on.	No operator is logged on.	
	Call Pending	The acknowledge key was pressed at least once, but not all the events in a call were acknowledged.	No calls pending or all calls have been acknowledged.	Calls pending.
Line Card LEDs	Fault (Red)	N/A	The line card is operating normally.	Trouble or fault condition exists.
	Active (Green)	The line card is in active communication.	No Activity.	Indicates the line is ringing.
	Listen (Amber)	Comes on when operator acknowledges the listen-in call.	No listen-in occurring.	N/A

4.2.2 LCD Status Display

The status display is a 4-line 20 character (each line) back-lit LCD that shows the various alarm and function messages. It functions in all modes of operation (normal and programming mode). As the 9500 acknowledges calls and messages, it updates the calls on the LCD and silences the alert tone.

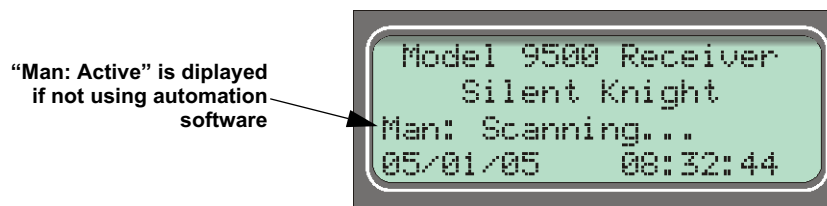

Figure 4-2 LCD Display

4.2.2.1 Adjusting LCD Contrast

The LCD is factory set at the highest contrast level and for most installations will not need to be adjusted. Use these steps to change the LCD contrast if the brightness of the room or the location in which the receiver is located should require a contrast change:

1. Press and hold both the up arrow and the left arrow keys at the same time. (See Figure 4-3.)



Figure 4-3 Contrast Adjustment

2. Release the up and left arrow keys when you reach the desired contrast level.

4.2.2.2 LCD Abbreviations

Many of the words used on the LCD are abbreviated to accommodate 20 characters per line. Table 4-3 compares the event that is reported to how it is output to the LCD and printer.

Table 4-3: LCD and Printer Abbreviations

Event	LCD	Printer	Event	LCD	Printer
Alarm	Alrm	Alarm	Test	Test	Test
Trouble	Trbl	Trouble	Listen-in	Lstn	Listen
Restore	Rstr	Restore	System	Sytm	System
Supervisory	Sprv	Superv	Access	Accs	Access
Opening	Open	Opening	Report	Rprt	Report
Closing	Clos	Close	Cancel	Cncl	Cancel
Remote	Rmot	Remote	Zone Number	Z#	Zone
Disable	Dsbl	Disable	Door Number	D#	Door
Bypass	Byp	Bypass	User Number	Us#	User
Unbypass	Uby	Unbypass	Area Number	A#	Area

4.3 Initial System Power Up

Apply power to the 9500 by plugging in the AC power cable and connecting the backup battery (if used). When the 9500 powers up, you will see the LCD display a sequence of screens. Power up will take several minutes. When power up is complete and everything is operating normally, the LCD display looks like Figure 4-2. The 9500 defaults to manual operation on power up. To select automatic operation see Section 5.4.1.1.

Note: You must reprogram the time and date whenever the main power is removed.

4.4 Log On / Log Off

Persons operating the 9500 must log on and off the system. This is a way of keeping track of whom is operating the system at any given time. You can program a total of 40 codes. Each code will be assigned to one of two user profiles (Installer profile or Operator profile). (See Section 4.4.3 for default user codes.)

4.4.1 Installer Profile

The Installer profile will have access to all options on the main menu (see Table 4-4 for “Main Menu” options).

4.4.2 Operator Profile

The Operator profile has access to fewer main menu options than the Installer profile (see Table 4-4). These options allow the operator to perform basic operation of the 9500. Both profiles can acknowledge all calls and events. See Section 4.6 for detailed information on the main menu options.

Note: You must have at least one Installer Profile Code programmed in the system at all times.

Table 4-4: Main Menu Option Items by Profile

Installer Profile	Operator Profile	Menu Options
✓	✓	Call History
✓	✓	System History
✓	✓	System Info
✓	✓	Set Time & Date
✓	✓	System Restart
✓		Printer Menu
✓		Program Menu
✓		Diagnostics

4.4.3 Default User Codes

At initial power up, the system provides two default user codes. User code 1 defaults with an Installer profile and user code 2 defaults with an Operator profile. Table 4-5 shows the default codes and their profiles.

Table 4-5: Default User Codes

User Number	Default Code (PIN)	Default Profile
1*	9500	Installer
2	1111	Operator

* User code 1 can be changed but not deleted. User code 1's profile will always remain as "installer".

4.4.4 How to log on the system.

Follows these steps to properly log on to the system:

1. Press the  button.

The LCD will display Enter Log In Code:
[]

2. Enter your PIN code. (See Table 4-5 for default codes.)

Note: This screen will time out after 15 seconds.

3. Press the  button.

If the correct PIN is entered the LCD will display Installer # XX
User Name.

The "Operator Logged In" LED will also turn on.

If an invalid code is entered the LCD will display Access code not verified.

Note: If the previous user has not logged off, a new user can still log on by entering a PIN code. This will automatically log off the previous user and log in the new user.

4.4.5 How to log off the system.

Follows these steps to properly log off the system:

1. Press the  button.

The LCD will display

```
#nn User Name
Log Out
[ ]
```

Note: This screen will time out after 15 seconds.

2. Enter your PIN code. (See Table 4-5 for default codes.)

3. Press the  button.

If the correct PIN is entered the LCD will display User Name Logged out. The “Operator Logged In” LED will also turn off.

If an invalid code is entered the LCD will display Access code not verified.

4.5 Modes of Operation

This section describes the different modes of operation for the 9500 Receiver (normal mode and programming mode) and the options available in them.

4.5.1 Normal Mode

Normal mode consists of three options, one if the receiver is intended to be used with a automation system, one for manual operation, and one to just log the events without manual acknowledgments or automation communication.

4.5.1.1 Manual Operation

Requires a manual acknowledgment of each call or event from an operator.

How to Manually Acknowledge Calls:

When a the call pending LED is flashing and the on-board annunciator is beeping:

1. Press the  button to acknowledge the call.
2. Repeat step 1 until all calls are acknowledged and the display shows No More Data.

4.5.1.2 Automatic Operation

Event information is sent directly to the automation computer.

Note: If the automation system fails, the receiver will automatically switch to manual mode in less than 30 seconds. The switching time is twice the value set in Ack Timeout (See Table 5-5). The receiver will return to automatic mode after communication to the automation computer is restored.

4.5.1.3 Log Only

Log only mode will log event data without manual acknowledgments or communications with the automation computer. All event information is intended for printer output.

Note: On initial power-up the receiver will default in manual operation. The receiver can be set to automatic or log only operation in program mode (see Section 5.4.1).

4.5.2 Program Mode

In program mode all general, line card, and user profile options can be changed. See Section 5 *Programming* for more detailed information on programming the receiver or refer to the Quick Chart (Appendix A) for programming overview.

4.6 Main Menu

This section gives detailed information about the items available in the Installer/operator menu options, which this manual will refer to as the main menu. The menu items available to each logged on user is dependent on the profile assigned to that user (see Table 4-4 for menu items for each profile). The user profile is assigned to each user through programming (see Section 5.6 for programming user profiles).

4.6.1 How to display the Main Menu

Once a user has logged on to the system (see Section 4.4.4), follow these steps to view the main menu options:

1. Press  .

The LCD display will show the main menu options.

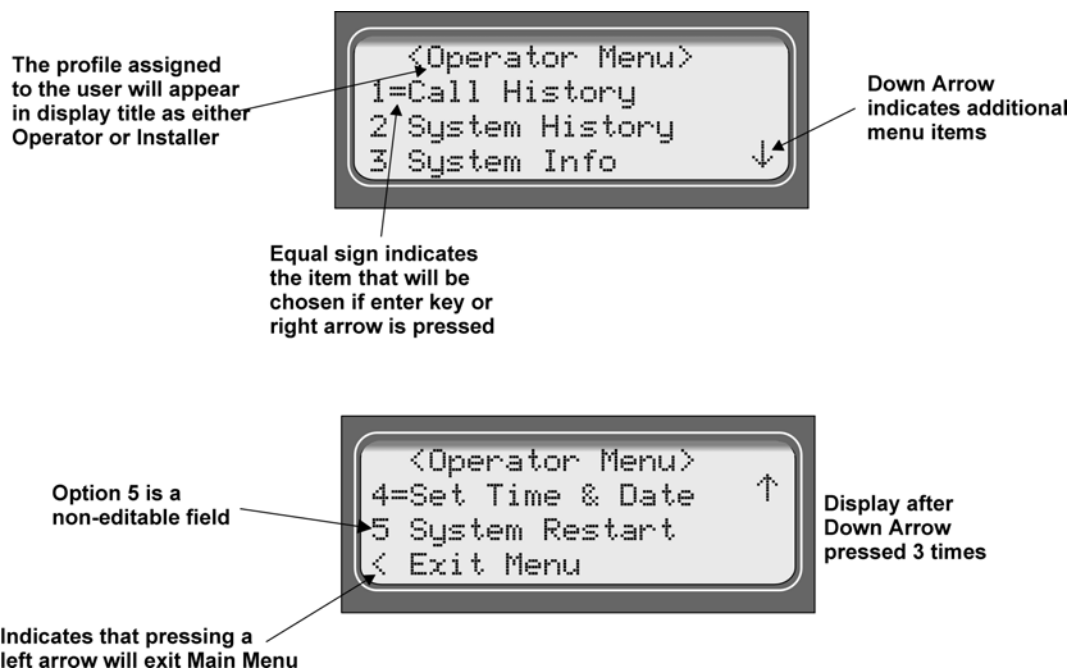

Figure 4-4 Main Menu Display

Note: The main menu display will remain visible for 15 minutes of idle time after which it will revert back to the manual or automatic display window. See Figure 4-2.

2. Choose the desired menu item. (See Figure 4-5.)

4.6.2 How to Maneuver Through Main Menu

Figure 4-5 indicates which keys on the touchpad are used to maneuver through the Main Menu.

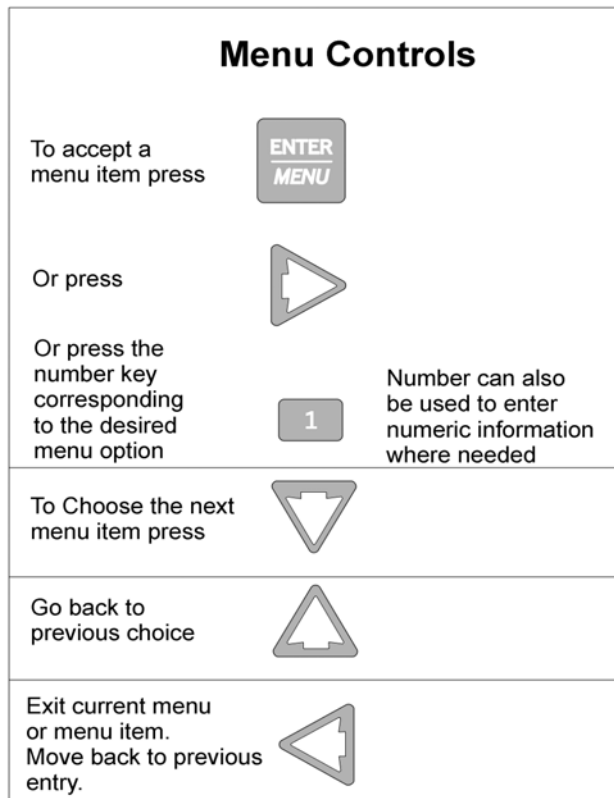

Figure 4-5 Main Menu Controls

4.6.3 Call History

Call history displays the calls that are in the history buffer.

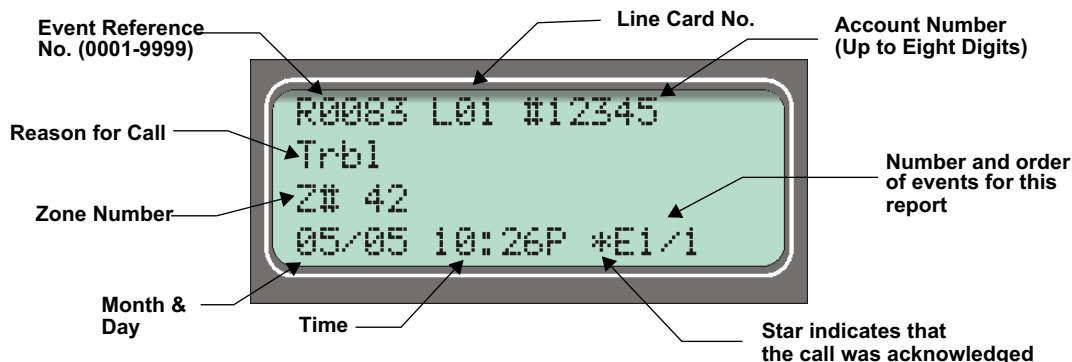



Figure 4-6 View of a Call History Screen

Note: The Letter preceding the line card number may appear as a “G” if the line card the call came in on is programmed for a hunt group. See “Misc. Line Opt.” in Section 5.5.2.8.

To display a specific event enter the reference number then press . Press the  to go to most recent call. See Table 4-3 for display abbreviations.

4.6.4 System History

System history displays any events that are stored in the history buffer. System events are any events related to the receiver operation such as line card faults, low backup battery, AC power loss, log in, log out, system program change, communication failure to a printer or automation system, etc.

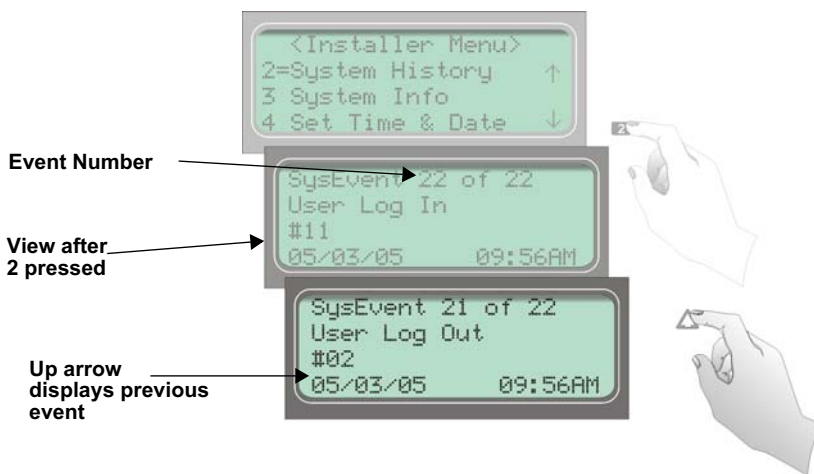



Figure 4-7 System History Display Sequence

Note: Up arrow moves back to the previous event that occurred.

To display a specific event enter the event number (see Figure 4-7) then press .

Press  to go to most recent call.

4.6.5 System Info

System Info is a non-editable screen that displays the model number, the software revision, software date code, receiver ID number. If a down arrow is pressed, the display will show the line card firmware information, which includes the model number, the software revision, the software date code, and letter revision.

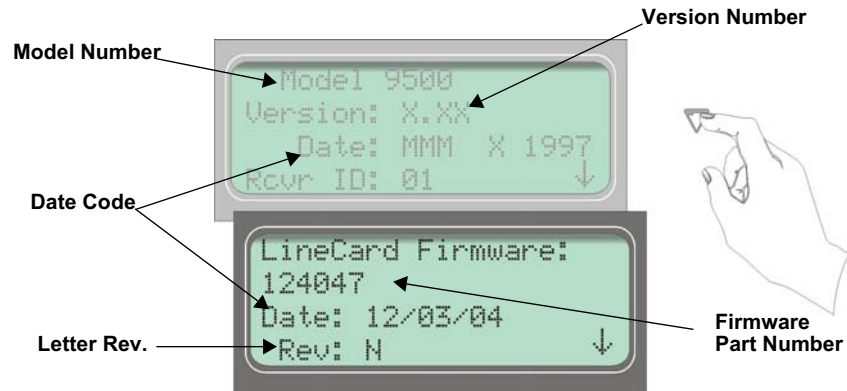

Figure 4-8 System Information Display

4.6.6 Set Time & Date

If Set Time & Date is selected, the operator can change the time and date currently displayed on the receiver. (See Figure 4-9 for setting time and date procedure.)

Set Time and Date

1. Press the Menu button.
2. Press the 4 button to

3. Set the Hour (1 to 12). The field to be changed flashes.



4. Set the Minutes. The field to be changed flashes.

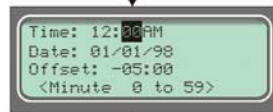

5. Set time to AM or PM. The field to be changed flashes.



6. Set the Month. The field to be changed flashes.

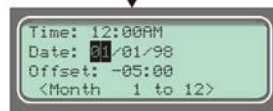

7. Set the Day. The field to be changed flashes.



8. Set the Year (0 to 99). The field to be



9. Set Greenwich mean time offset (+ or -). The field to be



10. Set the number of hour offset from Greenwich mean time.

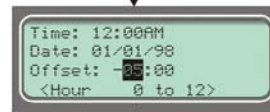

11. Set the number of minutes (in 10 minute increments) offset from Greenwich mean time.



12. Press Enter button at the correct time to synchronize with.

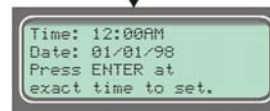

Figure 4-9 Setting Time and Date Program Sequence

4.6.7 System Restart

System restart allows the operator or installer to restart the receiver. An installer has the option to set the receiver back to factory default settings, while an operator can only restart the receiver.

Note: The time and date set in the receiver will be saved. However, all of the call history will be lost





Figure 4-10 System Restart Display

Follow These Steps to restart the receiver:

Note: All messages must be acknowledged before a system restart procedure can be performed. If all messages are not acknowledged, cycle the receiver's power to restart the system. If the power is cycled all unacknowledged messages will be lost.

1. Log on to the receiver (see Section 4.4.4 for log on procedure).

2. Press  to view the main menu items.

3. Press  for System Restart.



The display reads 

4. Press  or  to toggle No to Yes.

5. Press . Users with an operator profile are done at this point.

The display reads 

Note: This display will only appear if the logged on User has an Installer Profile (see section 4.4.1).

6. Press  or  to toggle between No and Yes.

Note: If you choose Yes all line card and user custom programming will be lost.

4.6.8 Printer Menu

In the print menu you can print customized reports by the type of alarm (as defined by UL 864, Section 72.15F), edit the desired print output, configure output for your printer.



Figure 4-11 Print Menu Items

Table 4-6: Printer Menu Choices

Printer Menu	Choice 1	Choice 2	Comments	
Print Report	Call History	Priority 1 (Life safety signals-Fire, Duress)	Y Indicates that this item will print on this report. N Indicates that this item will not print on this report.	
		Priority 2 (Property safety signals-Burg.)	The call History print will execute once you exit from "Choice 2".	
		Priority 3 (Supervisory signals)	Note: Choice 2 settings are not retained in flash memory and have to be chosen for each call history printing.	
		Priority 4 (Trouble signals)		
		Priority 5 (All other signals)		
	System History		This option prints all the system events in the event history buffer.	
	System Config	Print All		Print all of the receiver and line card data.
		Program Data		Print just the systems programmed data.
		Line Card #		Print line card configurations per line card.
	Test Page			Print a test page.

Table 4-6: Printer Menu Choices

Printer Menu	Choice 1	Choice 2	Comments
Edit Evnt Format	Date/Time	Y or N	Y = date and time will print for each report message to the printer. N = Date and time will not print for each report message to the printer.
	Format Type	Y or N	Y = The reporting format type of the calling control panel will print for each report message to the printer. N = The reporting format type of the calling control panel will not print for each report message to the printer. Note: The Format Type will be listed as a number, which represents the format used for that communication.
	Ref Number	Y or N	Y = The reference number will print for each report message to the printer. N = the reference number will not print for each report message to the printer. See Figure 4-6
	Call Sep	Y or N	Y = Print a dashed-line between each message report to the printer. N = Do not print a dashed-line between each message report to the printer.
	Device Num	Y or N	Y = Print the device number of the reporting message to the printer. N = Do not print the device number of the reporting message to the printer.
	Prt Condensed	Y or N	Y = Event information printed in an abbreviated format, reducing each event to one printed line. Use to save paper. N = Default. Event information printed in standard, longer format. Each event uses three lines when printed.
Config Printer	Line Terminator	CR or CRLF	CR = Carriage return. CRLF = Carriage return and line feed.
	Offline Time	0 - 60 seconds	How long the receiver waits before giving a trouble indication after communication is lost with the printer. The default setting is 2 seconds. (30 second maximum for UL applications.)
	Switch Delay Time	0 - 60 seconds	The duration the receiver waits before switching to the backup printer after communication is lost with the primary printer. The default setting is 20 seconds.

4.6.8.1 Print Report

Through the print report option you can choose to print the call history, system history, system configuration information, or just print a test page.

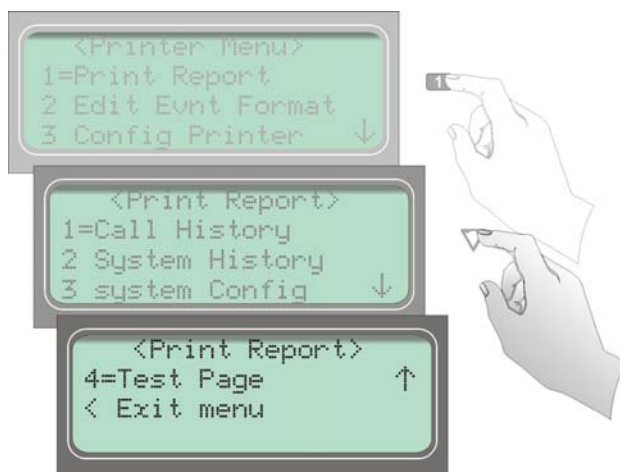

Figure 4-12 Print Report Menu Items

How to Print Call History

Follow these steps to print the call history:

1. Log on to the receiver (see Section 4.4.4 for log on procedure).
2. Press **ENTER** **MENU** to view the main menu items.
3. Press **6** for the printer menu. (See Figure 4-11.)
4. Press **1** for print report menu. (See Figure 4-12.)
5. Press **1** for call history options.

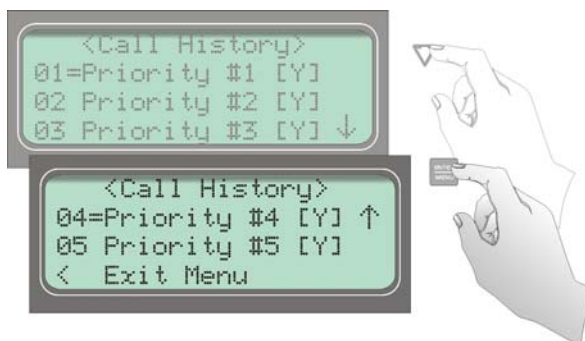









Figure 4-13 Call History Options

6. Press **▲** or **▼** to move through the call history menu choices. See Figure 4-13.

7. When the equal sign highlights the call history items you desire to print for this report press  or  to toggle the setting between Y (yes print) or N (don't print).
8. Press  to exit menu.

How to Print System History

Follow these steps to print the system history:

1. Log on to the receiver (see Section 4.4.4 for log on procedure).
2. Press  to view the main menu items.
3. Press  for the printer menu. (See Figure 4-11.)
4. Press  for print report menu. (See Figure 4-12.)
5. Press  to print the system history.
6. Press  to exit menu.

How to Print System Configuration

Follow these steps to print the system configuration:

1. Log on to the receiver (see Section 4.4.4 for log on procedure).
2. Press **ENTER MENU** to view the main menu items.
3. Press **6** for the printer menu. (See Figure 4-11.)
4. Press **1** for print report menu. (See Figure 4-12.)
5. Press **3** to view system configuration options. See Figure 4-14.

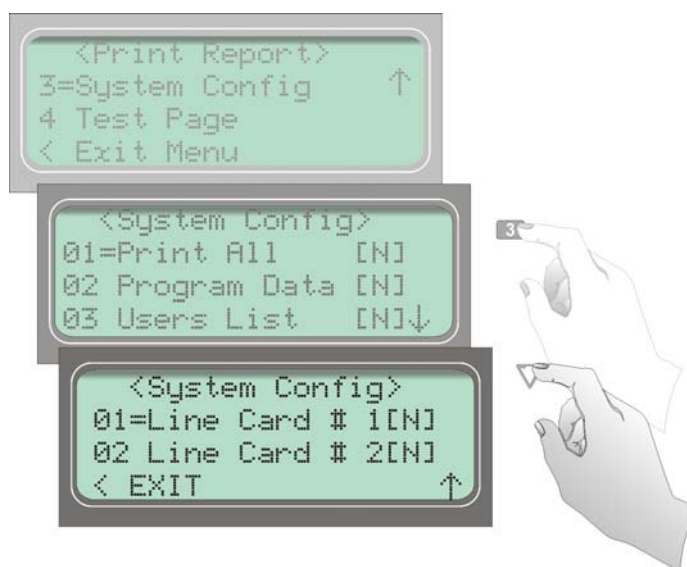







Figure 4-14 System Configuration Print Items

6. Press **▲** or **▼** to move through the system configuration print choices.
7. When the equal sign highlights an option press **ENTER MENU** or **▶** to toggle the setting between Y (yes print) or N (don't print).
8. Press **◀** to print the data and exit menu.

Note: These choices are not saved to flash memory and will have to be chosen each time that print system configuration is entered.

How to Print a Test Page



Follow these steps to print a test page:

1. Log on to the receiver (see Section 4.4.4 for log on procedure).
2. Press  to view the main menu items.
3. Press  for the printer menu. (See Figure 4-11.)
4. Press  for print report menu. (See Figure 4-12.)
5. Press  to print a test page.
6. Press  to exit menu.

4.6.8.2 Edit Event Format

Edit event format allows you to configure what information will print on reports to the receiver.

Follow these steps to configure the report format:

1. Log on to the receiver (see Section 4.4.4 for log on procedure).
2. Press  to view the main menu items.
3. Press  for the printer menu. (See Figure 4-11.)
4. Press  for event format menu items. (See Figure 4-15.)

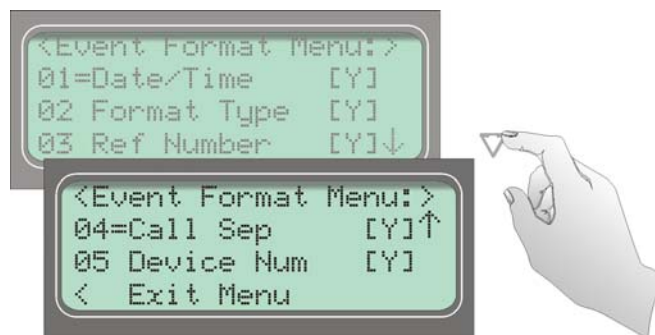





Figure 4-15 Event Format Menu Items

5. Press  or  to move through the event format choices. (See Table 4-6 for choice definitions)
6. When the equal sign highlights an option press  or  to toggle between Y (yes print) or N (don't print).

Note: These settings are saved to flash memory.

7. Press  to exit menu.

4.6.8.3 Configure Printer

Depending on the printer you are using it may require that this be set to either carriage return or carriage return with a line feed.

Follow these steps to configure the printer:

1. Log on to the receiver (see Section 4.4.4 for log on procedure).

2. Press  to view the main menu items.

3. Press  for the printer menu. (See Figure 4-11.)

4. Press  for configure printer menu items.

The display will be flashing on the line terminator field.

5. Press  or  to toggle between CR or CRLF. (See Table 4-6.)

6. When the desired setting is flashing press .

The display will now flash on the offline time field.

7. Enter the desired time (from 01-99 seconds), 30 second maximum in UL applications.

8. Press .

The display will now flash on the switch delay time field.

9. Enter the desired time (from 01-99 seconds).

10. Press .

11. Press  to exit menu.

4.6.9 Program Menu

If program is selected from the main menu the system will enter into “Program Mode”. (See Section 4.5 for information on modes of operation.) In program mode you can program all the general options, line card options, and user list. (See Appendix A for programming *Quick Reference Chart*.)



Figure 4-16 Program Menu Items

4.6.10 Diagnostics Menu

The diagnostics menu items can be used while testing and troubleshooting the system.

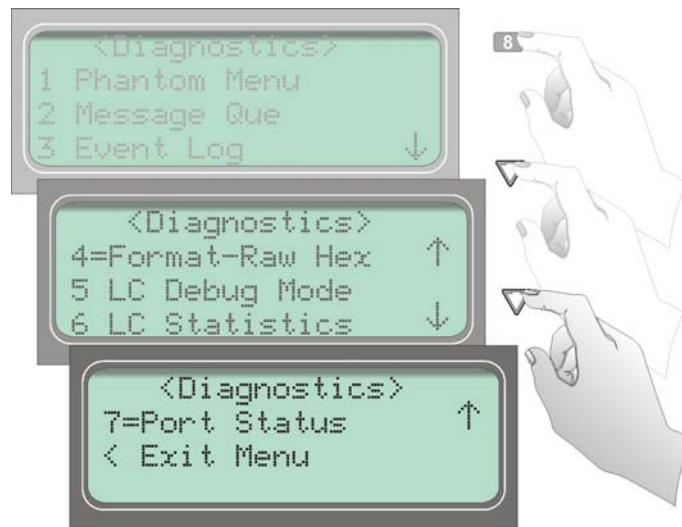

Figure 4-17 Diagnostics Menu Items

4.6.10.1 Phantom Menu

The phantom menu contains list of various communication format phantom signals (see Table 4-8) that can be used to test the receiver or automation software configurations. For example, you set a line card parameters for a particular communications format and would know like to verify that this new configuration will communicate with other communication formats, you can send phantom signals in the formats you wish to test that line card with.

Table 4-7: Phantom Signals Formats List

Choice	Format
01 DCS	DCS
02 CID	Contact ID
03 ITI	ITI format
04 BFSK	BFSK
05 3/1	3/1 format
06 3/2	3/1 format w/checksum
07 4/1	4/1 format
08 4/2	4/2 format
09 FSK0	FSK0
10 FSK1	FSK1
11 FSK2	FSK2
12 SIA D1	SIA D1
13 ADM42 Cksum	Ademco 4/2 format w/ checksum
14 SIA D1 Cksum	SIA D1 w/checksum
15 ACRON TOUCH TONE	Acron Touch Tone
16 ADM41 Cksum	Ademco 4/1 format w/ checksum
17 FBI 4+3+1	FBI 4+3+1
18 Modem IIE	Modem Iie format
19 SIA-2000	SIA 2000 format

4.6.10.2 Message Que

Message Que gives a visual indication of how full is the message queue. It does this with both a percentage indication and a bar graph (made of *'s). Each * is approximately 5%.

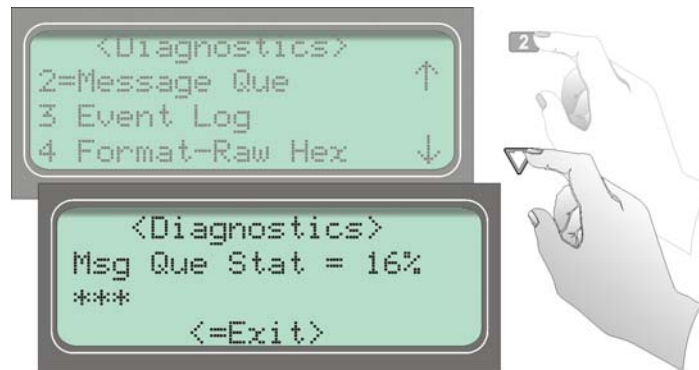

Figure 4-18 Message Queue Level

4.6.10.3 Event Log

Event Log allows you to print out a certain range of reference numbers to the port designated to diagnostics. This can be used as a troubleshooting tool while correlating alarm messages from the receiver to the automation computer.

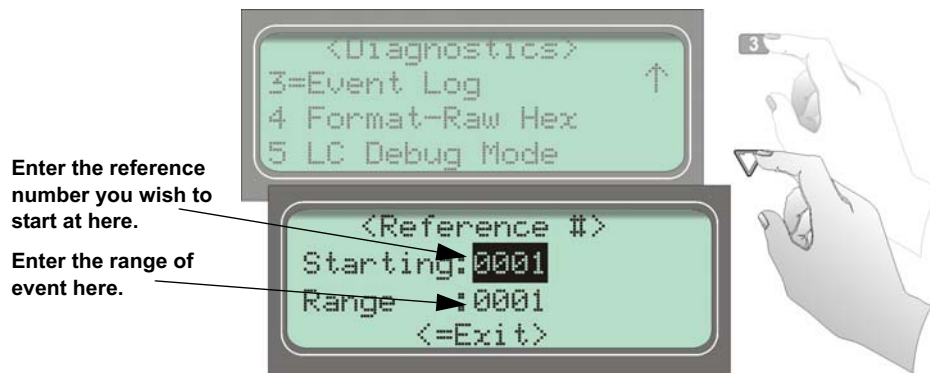

Figure 4-19 Event Log Display

For example, if the automation computer indicated a report that you are not familiar with, you would enter the reference number for that report in the event log and the raw data would be output to the diagnostic port. From the raw data you could determine what the signal was and make an adjustment to the automation computer for future signals like that one.

4.6.10.4 Format

Format designates the type of output you wish for the Event Log report. The output format can be in raw ASCII, a printer format, or one of the receivers automation communication formats. See *Automation Communication Protocols Reference Guide* (PN 151393) for automation protocols.

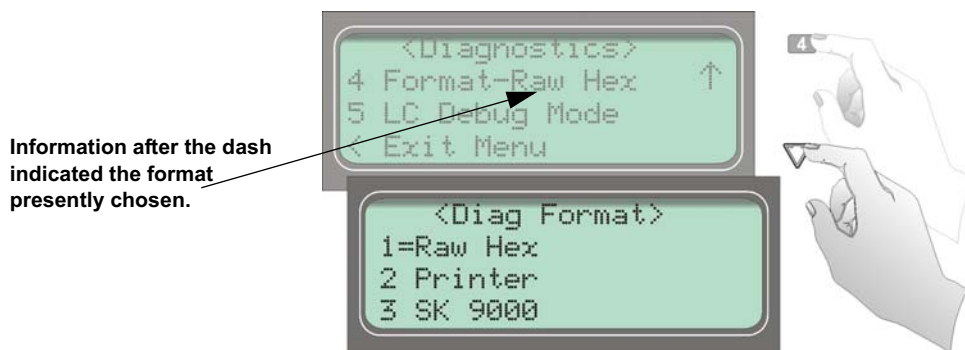

Figure 4-20 Diagnostic Formats

4.6.10.5 LC Debug Mode

LC debug enables the receiver to generate detailed history of handshake sequences to the call buffer. This information can be used for troubleshooting.

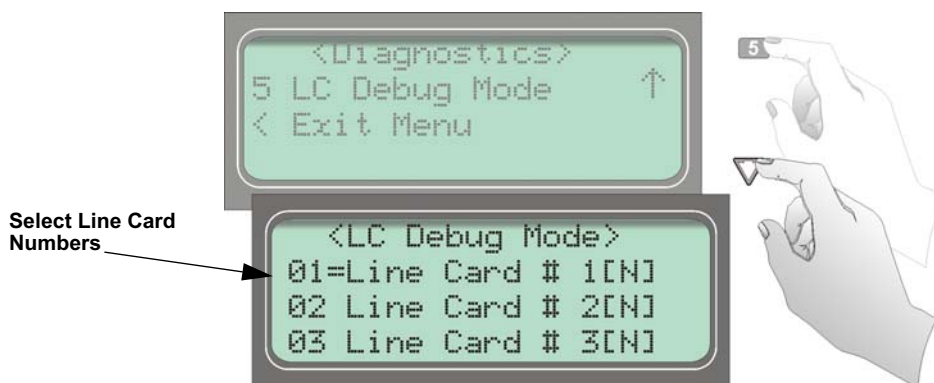





Figure 4-21 Select LC Debug Mode by Line Card

Use  or  to toggle the line card selection between “Yes” or “No”. Press  to exit and “Yes” to save changes.

4.6.10.6 LC Statistics

The LC (Line Card) statistics allows you to view the call statistics of a specific line card in comparison to the total number of calls received.

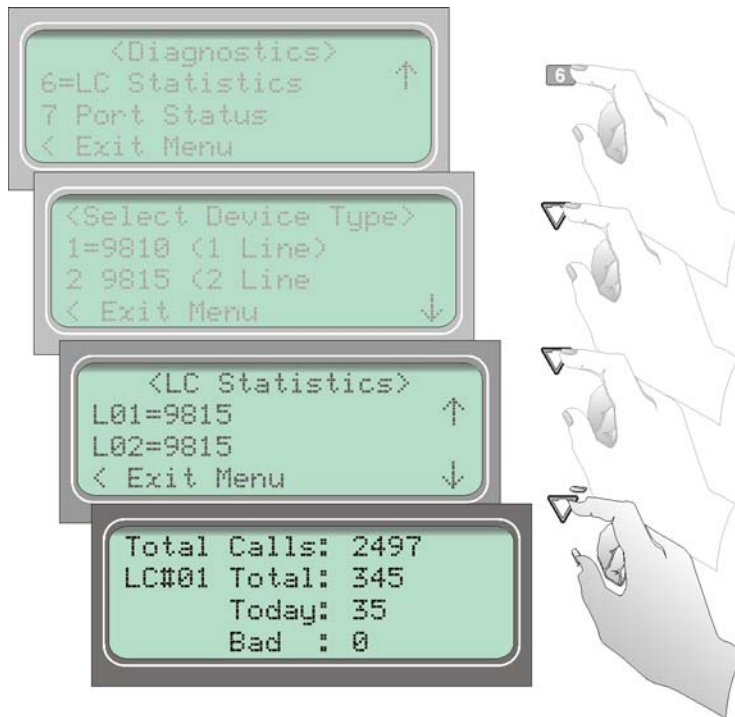



Figure 4-22 Line Card Statistics Display

To view call statistics for a line card, follow these steps:

1. From the installer menu (See Section 4.4) press **8** for Diagnostic menu.
2. Select **6** for LC Statistics. See Figure 4-22.
3. Select the device type for which you want to view the statistics.
4. Select the number of the line card you wish to view. See Figure 4-22.
5. Press  to exit.

4.6.10.7 Port Status

Port status allows you to view the current status of any of the communication ports.

To view the status of one of the communication ports, follow these steps:

1. From the installer menu (See Section 4.4) press **8** for Diagnostic menu.
2. Select **7** for Port Status.



Figure 4-23 Port Status View of Serial Port

3. Select the communication port you wish to view. See Figure 4-23 and Figure 4-24.



Figure 4-24 Parallel Port Status View

Table 4-8: Abbreviation Display Character Meanings/High Low Status

Abbreviated Character	Meaning	↑ (Bit High)	↓ (Bit Low)
Serial Port (Com 1 & Com 2)			
DSR	Data Set Ready	Ready	Not Ready
DTR	Data Terminal Ready	Ready	Not Ready
CTS	Clear to Send	Ready	Not Ready
RTS	Request to Send	Ready	Not Ready
B	Receive Break	Received Break	Ready
F	Framing Error	Framing Error	Ready
P	Parity Error	Parity Error	Ready
O	Overrun Error	Overrun Error	Ready
Parallel Port			
LINE	Printer on-line status	Printer On-line	Printer Off-line
READY	Printer ready status	Printer ready	Printer not ready
PAPER	Paper status	Paper status OK	Out of paper

4. Press  to exit.

4.6.11 PC Connection

The PC Connection feature, as shown below, is for factory diagnostics and is not for use in the field by installers.

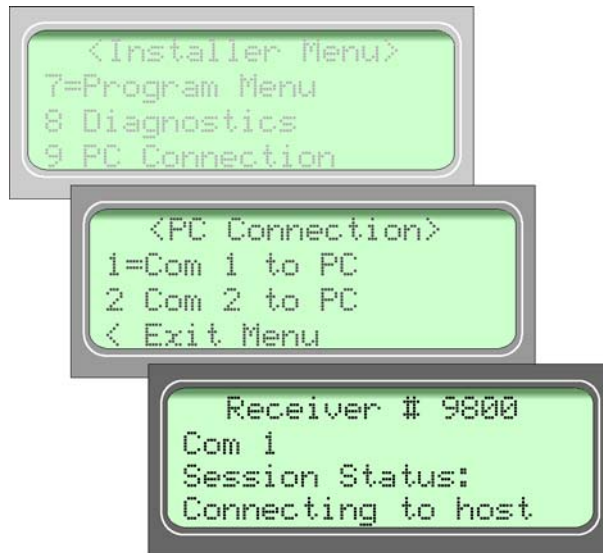

4.7 Listen-In and Hang Up

Note: See Section 2.3.2 for UL requirement on listen-in.

This section explains how to operate the receiver for listen-in calls. Some panels that perform listen-in send a listen-in indicator included in the reported message to the receiver. Any panel that does not send this message must be added to the Listen-In Account List (see Section 5.5.2.6).

When a listen-in call is received by the 9500, the LCD display will indicate the account number and (depending on the panel) the listen-in timeout period. The listen-in LED on the line card will be illuminated to confirm the line card indication.

4.7.1 Extend (Common) Listen-In Operation

Follow these steps to manually extend common listen-in time period:

1. Press  .
2. Enter the line card number.
3. Pick up the telephone the listen-in call is on. See Figure 4-25 for a diagram of how the listen-in phone should be connected (in parallel) with the phone line of the line card.

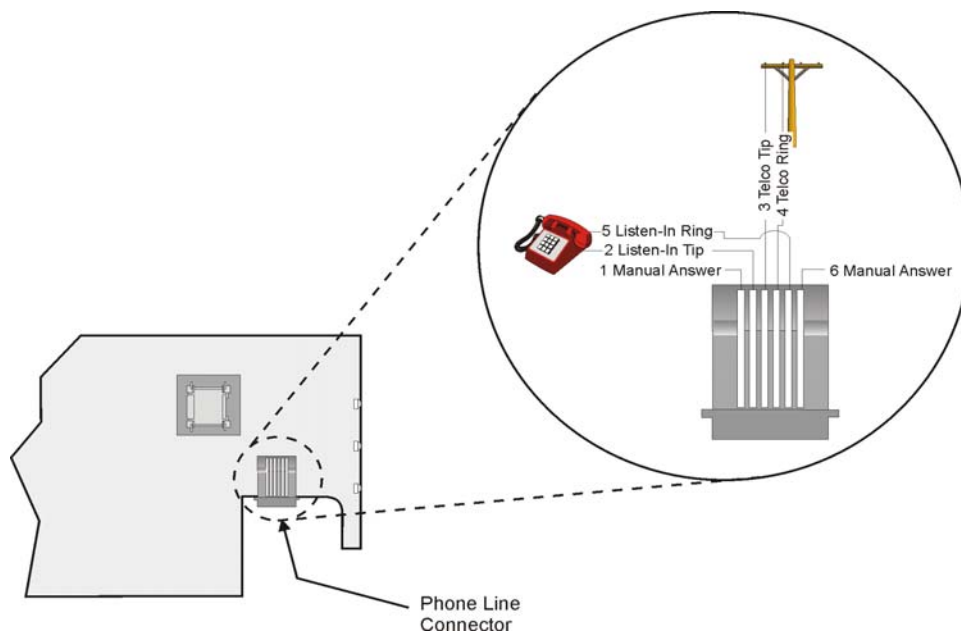

Figure 4-25 Phone Connector Pin-Out and Listen-in Wiring Diagram

4. Perform the listen-in procedures for that panel (refer to panel operation manual).

4.7.2 PBX Operation

Prior to performing listen-in functions on a PBX phone line system the receiver must be set up with the proper listen-in mode and PBX string. Refer to Sections 5.2 and 5.5.2.6 to properly program the receiver to handle PBX listen-in calls.

4.8 Testing the System

IMPORTANT:

The 9500 should be tested regularly to ensure complete and proper operation. Reports of automatic signal receipt must be verified daily. All testing, inspection, and maintenance must be done in accordance with NFPA 72 requirements.

Because there are so many variations in dialer parameters and phone line conditions, the only way to be absolutely certain that all subscribers can communicate with the 9500 is to test every subscriber's dialer individually. Subscribers must test their communicators every 30 days to make sure the 9500 receives the information.

When you install a new 9500, test every manufacturers' panels for each format. This is necessary because different manufacturers' panels may operate differently even if all panels use the same format.

Section 5

Programming

This section lists the programmable features in programming mode and the procedures for each of them. The options available are General Options, line card options, and user options.



5.1 UL 864 Programming Requirements

NOTICE TO USERS, INSTALLERS, AUTHORITIES HAVING JURISDICTION, AND OTHER INVOLVED PARTIES: This product incorporates field programmable software. In order for the product to comply with the requirements in the Standard for Control Units and Accessories for Fire Alarm Systems, UL 864, certain programming features or options must be limited to specific values or not used at all as indicated below.

Programming Option	Permitted in UL 864 (Y/N)	Possible Settings	Settings Permitted in UL 864
Battery Backup Cfg	Yes	No Battery Bkp DC Bkp Battery Bkp	Battery Bkp

5.2 How to Enter Program Mode

Follow these steps to enter into program mode:

1. Log on to the receiver (see Section 4.4.4 for log on procedure).
2. Press the  button.
3. Press the  button.

The display will briefly display `Initializing`









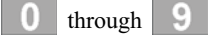

`Please wait . . .`

4. Select the option you wish to program. See Appendix A for a quick reference chart of all programming options.

5.2.1 Programming Fields

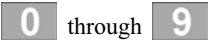
In program mode there are three types of programming fields that data can be entered into. Table 5-1 list the three types of fields and the various parameters associated with them.

Table 5-1: Types of Programming Fields

Type of Field	Control Keys	Comments
Numeric	 through  or   keys	These fields require a numeric entry only.
List	  keys	Predefined choices are put in a list and can be selected by pressing the up or down arrow keys.
Edit	 through  or   keys	Enter a number from the numeric keypad or enter any special characters by pressing the up or down arrow keys.

5.2.2 How to Maneuver Around in Program Mode

Figure 5-1 shows what keys on the touchpad are used to maneuver in program mode.

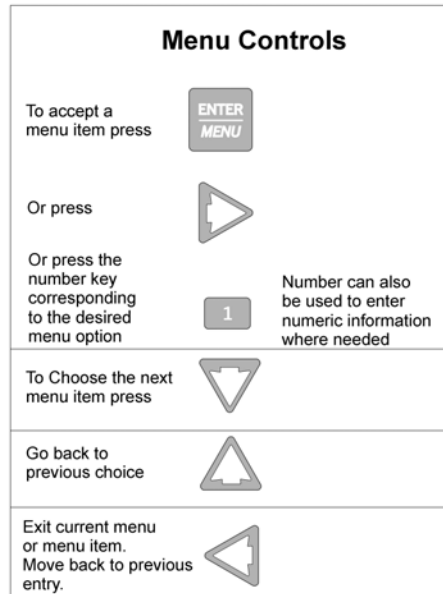

Figure 5-1 Programming Controls

5.3 Programming Choices

In programming mode your first set of choices are General Options, line card options, and user list. (Each of these choices will be described in greater detail in the following sections.) Figure 5-2 shows what the display will look like before and after the down arrow is pressed. See Appendix A for a quick reference chart of all programming options.



Figure 5-2 Program Menu Choices

5.4 General Options

This section describes how to configure General Options under the Program menu (see Figure 5-3). You can configure the following items from General Options:

- Receiver operation mode
- Display options
- Communications options
- System options
- Message queue options

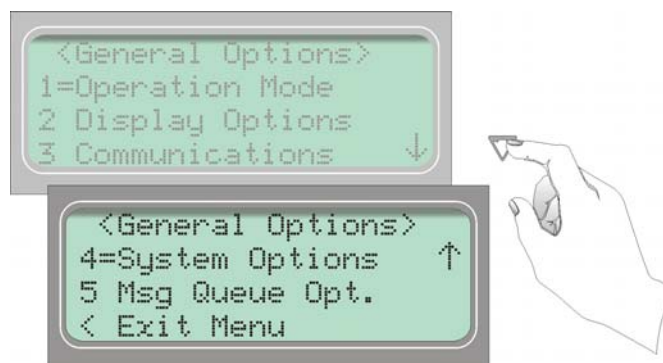

Figure 5-3 General Options Display

5.4.1 Operation Mode

Operation mode chooses how the receiver will operate in normal mode (manual, automatic or log only operation). See Table 5-2 for a description of choices available under the Operation Mode menu item.

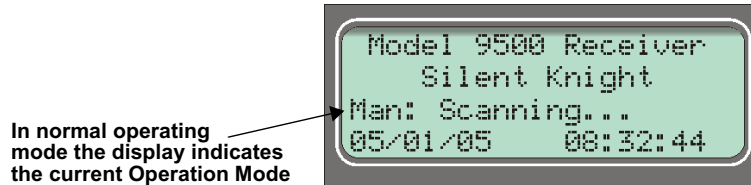

Figure 5-4 Normal Operating Mode Display Indicating Manual Operation

Table 5-2: Operations Mode Options and Descriptions

General Options Items	Level 1 Choices	Level 2 Choices	Level 3 Choices	Comments
Operation Mode	Manual			Requires manual acknowledgments of each call or event from an operator. Default.
	Log Only			All event information is internally acknowledged and put into event history buffer.
	Automatic			All event information is sent directly to the automation computer and must be acknowledged by the automation software.

5.4.1.1 How to Change the Operation Mode

Follow these steps to change the Operation Mode of the receiver:

1. Log on to the receiver. (See Section 4.4.4 for log on procedure.)

2. Press  .



3. Press  for program menu.

The display will briefly display `Initializing`
`Please wait . . .`

4. Press  to choose General Options.

5. Press  to choose Operation Mode.

The current operation mode will flash in the display.

6. Press  or  to move through the Operation Mode choices.

Note: Each additional press of the up or down arrow key will toggle the Operation Mode setting to the next choice.

7. When the display flashes on the desired operation mode, press  .

5.4.2 Display Options

Display options lets you customize the visual outputs of the receiver. These items include language formats, the time display, how events are sorted to the LCD display, or whether or not to hold unacknowledged events. Table 5-3 lists the available choices and gives a description of those choices.

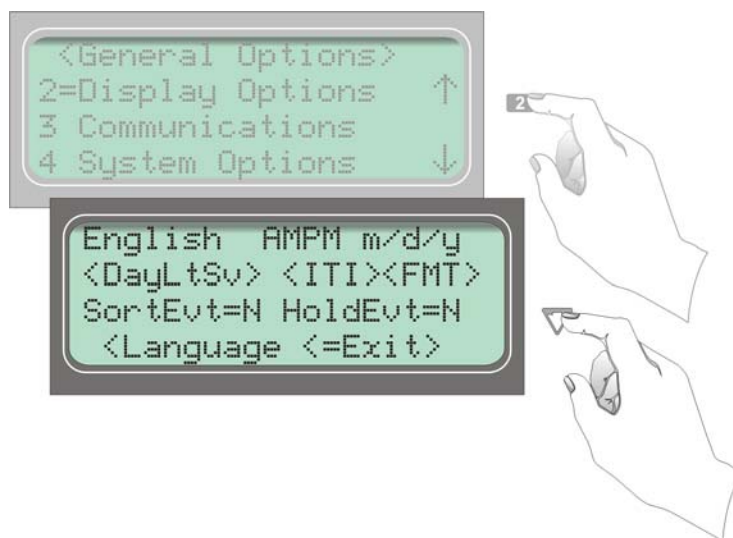

Figure 5-5 View of Display Options







Table 5-3: Display Options and Descriptions

General Options Items	Level 1 Choices	Level 2 Choices	Level 3 Choices	Comments	
Display Options	Language	English		Default: English. See Section 5.4.2.1.	
		español			
	Time Format	AM/PM		AM/PM is used for 12 hour time clock displays. Default: AM/PM. See 5.4.2.2.	
		24 Hour			Military time standard. See Section 5.4.2.2 for step-by-step instructions.
	Date Format	M/D/Y		M = month, D = day, and Y = year. Default: M/D/Y. See Section 5.4.2.3.	
		Y-M-D			
		D-M-Y			
	Daylight Saving Time	Yes/No		Default: Yes. See Section 5.4.2.4.	
		Start Month			Jan –Dec
		Start Week			1st – 4th and Last
End Month		Jan –Dec			
	End Week	1st – 4th and Last			







General Options Items	Level 1 Choices	Level 2 Choices	Level 3 Choices	Comments	
Display Options (cont.)	Edit ITI Options	Attempts	Yes	Affects printer output for ITI calls only. Default on all options: No. See Section 5.4.2.5.	
			No		
		CPU Time	Yes		
			No		
		CPU Type	Yes		
			No		
		Panel Rev	Yes		
			No		
		Arming Level	Yes		
			No		
	FMT (Edit Format options)	FSK1	Code	If "English" is selected then the printer and LCD output for calls of these formats will be text descriptions. If "Code" is selected then the printer and LCD output for calls of these formats will be the Code and Zone numbers. See Section 5.4.2.6.	
			English (default)		
		BFSK	Code		
			English		
		SIA	Code		If "English" is selected, the printer and LCD output will be text. If "Code" is selected then the printer and LCD will display the SIA codes followed by zone or other information. See Section 5.4.2.6.
			English (default)		
		CID	Code (default)		This option only affects the SK Expanded automation protocol output. If "English" is selected each event will be sent to the automation as two SIA events; the first with the two digit Group number and the second with the three digit ID number. If Code is selected, each event is sent as eleven digits; two digits Message type, one-digit Event Qualifier, three-digit Event Code, two-digit Group Number, and three-digit ID number. See Section 5.4.2.6.
			English		
		PULSE	0 .. 9		If 0 .. 9 is selected hexadecimal digits B through F are forced to 0 as in the way the 9000 receiver does it, or if 0 .. F is selected digits are sent as is.
			0 .. F		
SK9000		Packed	Each data packet to the automation contains a single (unpacked) or multiple (packed) events. See Section 5.4.2.6.		
		Unpacked			
ACRON		Zero	If set to Space then zero characters are translated as a space, if set to Zero then a zero is sent as a zero. See Section 5.4.2.6.		
		Space			

General Options Items	Level 1 Choices	Level 2 Choices	Level 3 Choices	Comments
Display Options (cont.)	FMT (Edit Format options)	HISPEED	SIA	If set to SIA then an event is translated to SIA format when sent to the automation computer. See Section 5.4.2.6.
			HiSpeed	
		Virtual	Printer	If set to Printer, line card slot numbers are sent to SK9000 automation and printer.
			All	If set to All, virtual line numbers are sent to SK9000 automation and printer.
	Hold Last Event	Yes		If Yes, LCD will display the last acknowledged event instead of the date/time display in the auto mode. In manual mode the display will show the oldest unacknowledged event. See Section 5.4.2.6.
		No		







5.4.2.1 How to Change Language Display

1. Enter program mode. (See Section 5.1.)
2. Press  for General Options.
3. Press  for Display Options.
4. Press  until the display flashes on the language format field.
5. Press  or  until the display flashes on the desired setting.
6. Press .

5.4.2.2 How to Change Time Format Display





1. Enter program mode. (See Section 5.1.)
2. Press  for General Options.
3. Press  for Display Options.
4. Press  until the display flashes on the time format field.
5. Press   until the display flashes on the desired setting.
6. Press .

5.4.2.3 How to Change Date Format Display

1. Enter program mode. (See Section 5.1.)
2. Press  for General Options.
3. Press  for Display Options.
4. Press  until the display flashes on the date format field.
5. Press  or  until the display flashes on the desired setting.
6. Press .

5.4.2.4 How to Set/Change Daylight Saving Time

The 9500 has an automatic Daylight Saving Time (DST) adjustment feature. Before January 2007, if this feature is enabled (set to *Yes*), the system clock will switch to DST on the first Sunday in April at 2:00 a.m. and revert to standard time on the last Sunday in October at 2:00 a.m. After January 2007, if this feature is enabled, the system clock will start and end DST according to the settings made in the *DayLtSv* under Display Options.







1. Enter program mode. (See Section 5.1.)
2. Press  for General Options.
3. Press  for Display Options.
4. Press  until the display flashes on the Daylight Saving Time (DayLtSv) field.
5. Press .
6. Make the desired changes.
7. Press .

5.4.2.5 How to Edit ITI Options

If one of the following ITI options is turned on (set to Yes) then the LCD and printer outputs will include that information.

- Attempts
- CPU Time
- CPU Type
- Panel Rev
- Arming Level









To set these Display Options follow these steps:

1. Enter program mode. (See Section 5.1.)
2. Press  for General Options.
3. Press  for Display Options.
4. Press  until the display flashes on the <ITI> savings field.
5. Press  .
6. Press  or  until the equal sign is on the desired option.
7. Press  to change the setting of that option.







Note: Additional presses of the enter button will toggle the setting between Yes and No.

8. Repeat steps 6 and 7 for any other ITI display options you wish to edit.

5.4.2.6 How to Edit Format (FMT) Options

1. Enter program mode. (See Section 5.1.)
2. Press  for General Options.
3. Press  for Display Options.
4. Press  until the display flashes on the FMT field.
5. Press .
6. Press  or  until the display highlights the desired format.
7. Press  or  to select the desired setting for that format.
8. Repeat steps 6 and 7 as needed for each format.

5.4.2.7 How to Set Hold Last Event

1. Enter program mode. (See Section 5.1.)
2. Press  for General Options.
3. Press  for Display Options.
4. Press  until the display flashes on the hold last event field.
5. Press  or  until the display flashes on the desired setting.
6. Press .

5.4.3 Communications

In the communication option the installer can configure the communication ports, automation configuration, annunciator configurations, and the auxiliary relay configurations. Table 5-4 lists the available choices and gives a description of those choices.

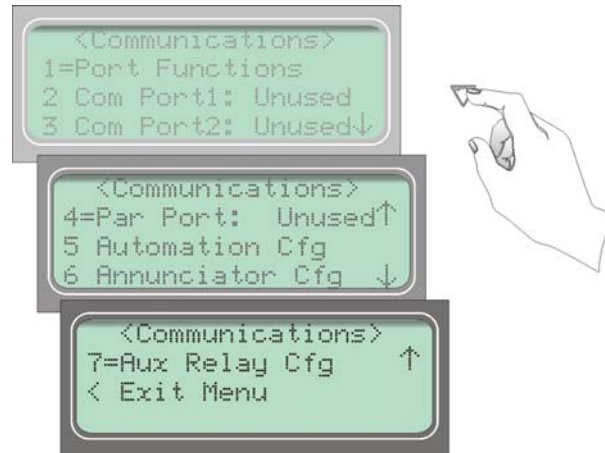

Figure 5-6 Communications Options Menu

Table 5-4: Communication Options and Description







General Options Items	Level 1 Choices	Level 2 Choices	Level 3 Choices	Comments	
Communications	Port Functions	Com1	Unused	Rules for Port Configuration: Functions in Brackets [] appear only if “Automation” is selected for Com1. Functions in { } appear only if “Printer” is selected in Com1 or Par. A function may be selected only once in the 3 ports (only one printer, only one Diag, etc.). All ports may be configured “Unused”. See Section 5.4.3.1.	
			Printer		
			Automation		
		Com2	Unused		
			Diagnostics		Outputs raw hex-ASCII code output.
			Printer		English output to printer.
			[Auto Bkp]		Acts as a backup print output port if a fault occurs with the primary automation port.
			[Auto Bkp Prn]		Acts as a backup print output port if a fault occurs with the automation port.
			{Print Bkp}		Acts as a backup printer port if a fault occurs with the primary printer port.
			Par		Unused
		Diagnostics			Outputs raw hex-ASCII code output.
		Printer			English output to printer.
		[Auto Bkp]			Acts as a backup print output port if a fault occurs with the automation port.

General Options Items	Level 1 Choices	Level 2 Choices	Level 3 Choices	Comments
Communications (cont.)	Com Port 1	Baud Rate	38400/19200/9600/ 7200/4800/2400/ 1200/600/300/110	Default: 19200. See Section 5.4.3.2.
		D (# Data Bits)	7, 8	Default: 8. See Section 5.4.3.2.
		S (# Stop Bits)	1, 2	Default: 1. See Section 5.4.3.2.
		P (Parity)	Even, Odd, Space, Mark, No	Default: None. See Section 5.4.3.2.
		F (Flow Control)	Hdwr	Unidirectional communication. Default. See Section 5.4.3.2.
			Sftwr	Bi-directional communication. See Section 5.4.3.2.
			None	No supervision. See Section 5.4.3.2.
	Init String		Two 20 character ESC command sequences. See Section 5.4.3.4.	
	Com Port 2	Same as Com Port 1		See Section 5.4.3.3.
	Par Port	Init String		Two 20 character ESC command sequences. See Section 5.4.3.4.
	Automation Config	Format	SK EXP, SK9000, SIA CIS, CAPS, FBI I220, ADEM 685, ITIComp, ITI Gen	See <i>Automation Communication Protocols Reference Guide</i> (PN 151393) for more information on automation formats. Additional ITI options described in Table 5-6. Default: SK9000. See Section 5.4.3.5.
		Hex	Y = Enabled	If enabled, any call data that is determined to be bad data will be output in Hex format. This option is only visible when SK 9000 format is selected. Default: Disabled. See Section 5.4.3.5.
			N = Disabled	
		Heart Beat	Y = Enabled	A supervisory signal that continually tests the communication link between the automation computer and the receiver. Default: Disabled. See Section 5.4.3.5.
			N = Disabled	
		Time (of Heartbeat)	10-600 Seconds	How often a supervisory signal (a heartbeat) is sent to the automation computer. Default: 0. See Section 5.4.3.5.
	Ack timeout	1 to 120 Seconds	15 seconds or less in UL applications. Default: 10 sec. See Section 5.4.3.5.	

General Options Items	Level 1 Choices	Level 2 Choices	Level 3 Choices	Comments
Communications (cont.)	Annunciator Configuration	Printer	Yes or No	Yes = will annunciate if an event, trouble or fault condition occurs. No = no annunciation if an event, trouble or fault condition occurs. Default for all options: Yes. See Section 5.4.3.6. * Listen In option must be set to No for UL installations.
		Bkp Printer		
Auto Comp				
Bkp Auto Comp				
Battery				
Device				
Line Fault				
AC Power				
Buffer Full				
Listen In*				
Call Pending				
	Aux Relay Cfg	Options the same as Annunciator Configuration. See Section 5.4.3.7. * Listen In option must be set to No for UL installations.		







5.4.3.1 How to Set Up Port Function

Port functions set up how each of the communication ports will be used. Before you start to set up the port functions review the rules for port functions in Table 5-4.

1. Enter program mode. (See Section 5.1.)
2. Press  for General Options.
3. Press  for Communications.
4. Press  to set port functions.
5. Press  or  until the display flashes on the desired port setting.
6. Press .
7. Repeat steps 5 through 6 until all port functions are set.
8. Press  to exit menu.

5.4.3.2 How to set Com Port 1 Parameters

Set the baud rate, the number of data bits, number of stop bits, the parity, and the flow control (see Table 5-4 for choice details).







1. Enter program mode. (See Section 5.1.)
2. Press  for General Options.
3. Press  for Communications.
4. Press  to set Com Port1 parameters.
5. Press  or  until the display flashes on the desired port setting.
6. Press .

Note: See “How to Edit Init String” in Section 5.4.3.4.

7. Repeat steps 5 through 6 until all parameters are set.
8. Press  to exit menu.

5.4.3.3 How to Set Com Port 2 Parameters

Set the baud rate, the number of data bits, number of stop bits, the parity, and the flow control (see Table 5-4 for choice details).

1. Enter program mode. (See Section 5.1.)
2. Press  for General Options.
3. Press  for Communications.
4. Press  to set Com Port2 parameters.
5. Press  or  until the display flashes on the desired port setting.
6. Press .

Note: See “How to Edit Init String” in Section 5.4.3.4.

7. Repeat steps 5 through 6 until all parameters are set.
8. Press  to exit menu.

5.4.3.4 How to Edit Init String (Par Port)

An initialization string can be used to customize the output to the device connected to a port on the receiver.

For example, you can skip over perforations, set proportional spacing, or condense the print output to a printer.

Note: Refer to the user manual, of the device connected to the receiver, for special command sequences.

Follow these step to insert an initialization string:

1. Press  at the flashing <Init Str> field.

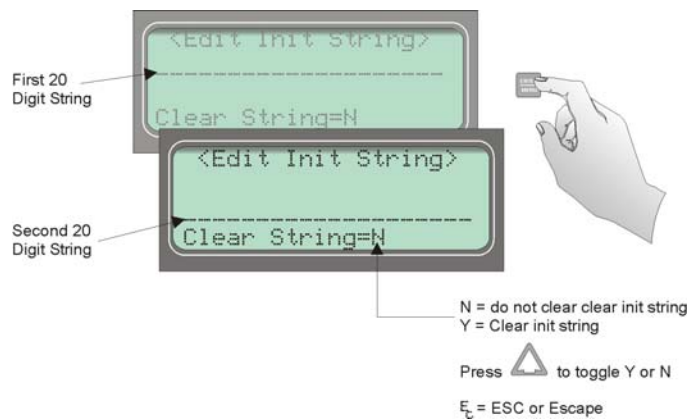

Figure 5-7 Initialization String Display







2. Press the  or  until the desire character flashes.

Table 5-5: Initialization String Characters

Character	Description
0-9	Numeric characters, which can be entered from the touchpad or up/down arrows.
a-z and A-Z	Alpha characters entered with the up/down arrows.
: _ - . , & * # ? E _c and space bar.	Special Characters entered with the up/down arrows.

3. Press , the next character position will flash.
4. Repeat steps 2 and 3 until the desired sequence is complete.
5. Press .
6. Repeat steps 2 through 5 for the second string.

To clear an init string:







1. At the Clear String field, press  until the desired option flashes (Figure 5-7).
2. Press .
3. Press  to exit menu.

5.4.3.5 How to Set Automation Communication

Through this option the automation communication format and parameters can be set up. (See Table 5-4 for format choices.)

How to Set the Format

Follow these steps to set the automation communication format.









1. Enter Program mode. (See Section 5.1.)
2. Press  for General Options.
3. Press  for Communications.
4. Press  to setup automation configuration.
5. Press the  or  button until the display flashes on the desired port setting.
6. Press .
7. Press  if you wish to exit menu or continue with heartbeat.

How Enable or Disable Hex Mode

When Hex Mode is enabled, any call data that is determined to be bad will output in a Hex format. This feature is only available if SK 9000 automation protocol is selected.

Note: This feature should be disabled if the automation software package that you are using does not recognize Hex data.









Follow these steps to enable or disable heartbeat:

1. Enter program mode. (See Section 5.1.)
2. Press  for General Options.
3. Press  for Communications.
4. Press  to set up automation configuration.
5. Press  until the Hex field is flashing.
6. Press  or  until the display flashes on the desired setting.
7. Press .
8. If you wish to exit, press  until you exit this menu.

How Enable or Disable Heartbeat

A heartbeat is a supervisory signal continually test the communication link between the automation computer and the receiver.





Follow these steps to enable or disable heartbeat:

1. Enter program mode. (See Section 5.1.)
2. Press  for General Options.
3. Press  for Communications.
4. Press  to set up automation configuration.
5. Press  until the Heartbeat field is flashing.
6. Press  or  until the display flashes on the desired setting.
7. Press .
8. If you wish to exit, press  until you exit this menu.

Set Heartbeat Time Period

This option determines how often the heartbeat is sent to the automation computer. For example, if the time is set to 60 seconds (default setting) then a heartbeat will be sent every 60 seconds.





Follow these steps to set the time period or the heartbeat:

1. Enter program mode. (See Section 5.1.)
2. Press **1** for General Options.
3. Press **3** for Communications.
4. Press **5** to set up automation configuration.
5. Press  until the Time field is flashing.
6. From the number keypad enter the desired number or press  or  until the display flashes on the desired setting.
7. Press .
8. If you wish to exit, press  until you exit this menu.

Ack Time (Acknowledge Time)

The acknowledge time is the duration that the receiver will wait for a response from the automation computer after a data packet has been sent. Data packets include all reports and heartbeats.

Follow these steps to set the time period or the heartbeat:

1. Enter program mode. (See Section 5.1.)
2. Press **1** for General Options.
3. Press **3** for Communications.
4. Press **5** to set up automation configuration.
5. Press  until the AckTimeout field is flashing.
6. From the number keypad enter the desired number or press  or  until the display flashes on the desired setting.
7. Press .
8. If you wish to exit, press  until you exit this menu.

ITI Options (Only Visible if ITI Gen or ITIComp Formats are Chosen)

These are options particular to the ITI automation format and can only be edited if one of these formats is used to communicate with the automation computer. See *Automation Communication Protocols Reference Guide* (PN 151393) for detailed information.

Follow these steps to set the ITI options:









1. Enter program mode. (See Section 5.1.)
2. Press  for General Options.
3. Press  for Communications.
4. Press  to set up automation configuration.
5. Press  until the ITI field is flashing.
6. Press .

Table 5-6: ITI Automation Format Options





Option	Choices	Default	Description
Log Recs	Y (Yes)	N	Log records identify the time and date of a incoming report.
	N (No)		
XID	Y (Yes)	N	Extended panel Identification code. See <i>Automation Communication Protocols Reference Guide</i> (PN 151393).
	N (No)		
SupCh		s	Supervisory Character is sent from the automation computer. The receiver will respond with an OKAY or supervisory record. See <i>Automation Communication Protocols Reference Guide</i> (PN 151393).
No Data		0	Identifies the no data character in the log record.
Generic Rev		6.1 & 6.2	6.1

Note: ITI automation formats are covered in greater detail in Automation Communication Protocols Reference Guide (PN 151393).





Log Recs (For ITI Formats):

1. At the flashing Log Recs field press  or  until the display flashes on the desired setting.
2. Press .
3. If you wish to exit, press  until you exit this menu.





XID (Extended ID for ITI Panels):

1. At the flashing XID field press  or  until the display flashes on the desired setting.
2. Press .
3. If you wish to exit, press  until you exit this menu.

SupCh (Supervisory Character):







1. At the flashing SupCh [E] field press  or  until the display flashes on the desired setting.
2. Press .
3. If you wish to exit, press  until you exit this menu.

NoData (No Data Character for Log Record):

1. At the flashing NoData[] field enter a digit from 0-9 from the touchpad or press  or  until the display flashes on the desired setting.
2. Press .
3. If you wish to exit, press  until you exit this menu.







5.4.3.6 How to Configure the On-board Annunciator Outputs

Program what will give a trouble annunciation or what will not annunciate from the on-board annunciator.

1. Enter program mode. (See Section 5.1.)
 2. Press  for General Options.
 3. Press  for Communications.
 4. Press  to set annunciator configuration.
A list of the annunciator output options appears.
 5. Press  or  to move through the annunciator output options.
 6. When the equal sign highlights the option you wish to change, press .
- Note: Additional presses of the enter button toggle the setting between “yes” or “no”. See Table 5-4.*
7. Repeat steps 5 through 6 for all annunciator options you wish to change.

5.4.3.7 How to Configure the Auxiliary Relay Outputs

Program what will give a trouble output to the auxiliary relay contact. (To program the normal state of the auxiliary relay see Section 5.4.4.)

1. Enter program mode. (See Section 5.1.)
 2. Press  for General Options.
 3. Press  for Communications.
 4. Press  to set relay configuration.
A list of the relay output options appears.
 5. Press  or  to move through the relay output options.
 6. When the equal sign highlights the option you wish to change, press .
- Note: Additional presses of the enter button toggle the setting between “yes” or “no”. See Table 5-4.*
7. Repeat steps 5 through 6 for all relay options you wish to change.

5.4.4 System Options

In System Options you can configure the backup battery configuration, the receiver ID number, and the normal state of the auxiliary relay. Table 5-7 list the available choices and gives a description of those choices.







Figure 5-8 System Options Display

Table 5-7: System Options

General Options Items	Level 1 Choices	Level 2 Choices	Level 3 Choices	Comments
System Options	Battery Backup Cfg	No Battery Bkp		No charging current applied to battery circuit. Receiver will not test battery output or give trouble annunciations. Default. See Section 5.4.4.1.
		DC Bkp		No charging current applied to battery circuit. Typically used for systems that use a UPS (uninterrupted power supply) for backup battery power. See Section 5.4.4.1.
		Battery Bkp		Charging current applied to battery circuit. See Section 5.4.4.1.
	Receiver ID No.	01-99		Default: 01. See Section 5.4.4.2.
	Bad Data Blocks	Strip Bad		An indicator is sent to the automation computer that indicates a bad data block was received. Default. See Section 5.4.4.3
		Send Bad		Same as Strip Data except the bad data block is sent with the indicator. See Section 5.4.4.3
	Auxiliary Relay Normal State	Off		Off= Deenergized. Default.
		Energized		On = Energized See Section 5.4.4.4.
	Clock Source	60 Hz		Receiver clock runs on 60Hz AC power input. See Section 5.4.4.5
		50 Hz		Receiver clock runs on 50Hz AC power input. See Section 5.4.4.5.
Int			Receiver clock runs on internal crystal. Use in areas where AC line frequency is not dependable. See Section 5.4.4.5.	







5.4.4.1 How to Change Backup Battery Setting

Through System Options the backup battery can be configured for the type of backup battery your installation site requires.

1. Enter program mode. (See Section 5.1.)
2. Press  for General Options.
3. Press  for System Options.
4. Press  or  until the display flashes on the desired setting.
5. Press .







To Exit press  until you return to the main menu.

5.4.4.2 How to Set the Receiver ID Number

1. In large central stations where calls may be coming in on several receivers at once, the automation software will need to identify which receiver it received a call from. This will help in troubleshooting if a problem occurred with the automation system or receiver.
2. Enter program mode. (See Section 5.1.)
3. Press  for General Options.
4. Press  for System Options.
5. Press  until the Receiver ID programming field is flashing Rcvr ID=.
6. The display will flash on the receiver ID number: Rcvr ID=.
7. Enter the desired receiver ID number (a number from 01 to 99).
8. Press .

5.4.4.3 How to Configure Output for Bad Data Blocks







This feature selects how bad data blocks will be sent from the receiver to the automation computer. If Strip Bad is selected then an indicator will be sent to the automation computer when a bad data block is received, but the actual bad data block will not be sent. If Send Bad is selected an indicator will be sent to the automation computer along with the bad data block.

1. Enter program mode. (See Section 5.1.)
2. Press  for General Options.
3. Press  for System Options.
4. Press  until display will flashes on the Bad Data Blocks: **Strip_Bad**
5. Press  or  until the display flashes on the desired setting.
6. Press .

To Exit press  until you return to the main menu.

5.4.4.4 How to Set the Normal State of the Auxiliary Relay Contact

The auxiliary relay contact is a Form C relay. This feature allows you to set the state of the auxiliary relay normally open contact when power is applied to the receiver.

1. Enter program mode. (See Section 5.1.)
2. Press  for General Options.
3. Press  for System Options.
4. Press  until display will flash on the auxiliary relay setting: Aux Relay=**Off**
5. Press  or  until the display flashes on the desired setting.
6. Press . To Exit press  until you return to the main menu.

5.4.4.5 Select the Receivers Clock Source

The receiver can use 50 Hz, 60 Hz, or an internal crystal to calculate time. Select the internal setting if you are in an area where the AC line frequency is not dependable and you wish to have the receiver calculate the time using an internal crystal. The internal crystal is not as accurate as the AC power source, and normally you should select 60 Hz or 50 Hz.

1. Enter program mode. (See Section 5.1.)
2. Press **1** for General Options.
3. Press **4** for System Options.
4. Press **▶** until display will flash on the auxiliary relay setting: Clk=**60Hz**
5. Press **▲** or **▼** until the display flashes on the desired setting.
6. Press **ENTER MENU**. To Exit press **◀** until you return to the main menu.

5.4.5 Message Queue Options

The Message Queue option lets you adjust some settings on how the receive handles incoming events. See Section 7 for trouble messages.



Figure 5-9 Message Queue Display

Note: The “Warning On” can be set from 10% to 99%, the “Warning Off” can be set from 1% to 90%. A minimum separation of 5% will be set between the On % and the Off%. For example, if the “Warning On” is set to 82% the “Warning Off” maximum setting can be 77%.

Table 5-8: Message Queue Option

General Options	Level 1 Choices	Level 2 Choices	Level 3 Choices	Comments
Message Queue Options	% Warning Lvl	On: 10 to 99%		Percentage full message queue must reach before a trouble indication occurs. Default: 75%. See Section 5.4.5.1.
		Off: 01 to 90%		Percentage message queue must drop to clear a trouble indication. Default: 50%. See Section 5.4.5.2.
	Event Release Sec.	1, 20 to 120 sec		Time from call beginning until events released to system. Default: 60 sec. See Section 5.4.5.3.

5.4.5.1 Set the Message Queue Warning On Level





Set the percentage of how full the message queue can get before the receiver indicates a “Message Queue Warning” condition.

1. Enter program mode. (See Section 5.1.)
2. Press **1** for General Options.
3. Press **5** for Message Queue Options.
4. Enter the level (in %) you wish the receiver message queue to get before it will indicate a message queue warning in the Wrn Lvl On field.
5. Press **ENTER MENU**.

To Exit press  until you return to the main menu.

5.4.5.2 Set the Message Queue Warning Off Level





Set the percentage level where the receiver will indicate a restore condition for a “Message Queue Warning”.

1. Enter program mode. (See Section 5.1.)
2. Press  for General Options.
3. Press  for Message Queue Options.
4. Press  until the display flashes on the **Off** field.
5. Enter the level (in %) you wish the receiver message queue to get before it will indicate a message queue warning restore.
6. Press .

5.4.5.3 Set the Event Release Time

Used to define the maximum amount of time (in seconds) that the receiver will hold an event in memory prior to sending it to automation, VFD, and printer. The time begins at the beginning of the call or on an acknowledgement.

Note: For 9815 line cards, if the Event Release setting is greater than the Call Hang-Up setting the receiver will not disconnect the line (panel) until the Event Release time has expired. The actual amount of time before the receiver disconnects a line may at times be greater than the actual programmed value for Call Hang-Up Time. An event in progress (Event Release) has to complete before the call hang-up takes effect.

1. Enter program mode. (See Section 5.1.)
2. Press  for General Options.
3. Press  for Message Queue Options.
4. Press  until the display flashes on the **Event Release** field.
5. Enter the event release time (001 or 020 to 120) in seconds.
6. Press .

5.5 Line Device Menu

You can add, edit, clear (delete), or view existing line cards from the Line Device Menu. Figure 5-10 shows the sequence used to reach the Line Card Menu. Appendix A shows all of the options available in the Line Device Menu.

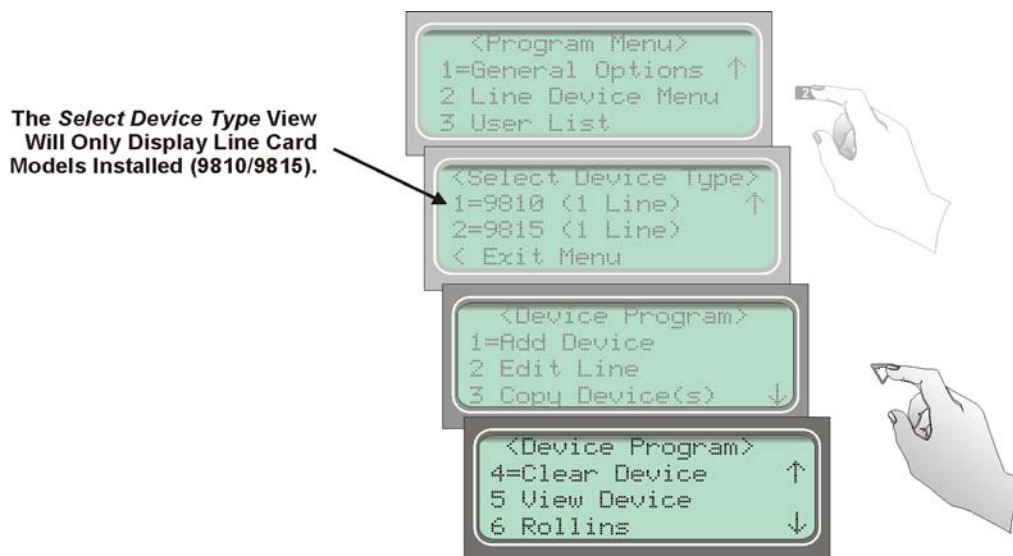











Figure 5-10 The Line Device Menu Options

5.5.1 Add Device

Line cards are added automatically if you power down the receiver and then add the line card. If, however, you swap out a line card with the receiver on, you will need to use the Add Device option.

To program in a new line card follow these steps:

1. Install the new line card. (See Section 3.4.)
2. Log on to the receiver. (See Section 4.4.4 for log on procedure.)
3. Press  .
4. Press  for the Program Menu.
The display will briefly display `Initializing`
`Please wait . . .`
5. Press  to choose Line Device Menu.
The display will show `<Select Device Type>`.
6. Press  if the line card is a 9810, and press  if the line card is a 9815. If you have only one line card model installed, only that model number will display.
7. Press  to add a new line card.
The display will show `<Add Device> _ _`
`Enter Device #:`
8. Enter the line card slot number (1-2).
9. Press  .
10. Press  to use line card defaults set at the factory, or press  to use copy the programming of another line card.

5.5.2 Edit Line Card

Important!

Due to the increasing number of formats a single line can accept and the wide variety of manufacturer's specifications for handshake/acknowledgment tones required for their digital dialers to communicate, Silent Knight strongly recommends the following for handshake tone order.

1. Some SIA DCS communicators respond to the 2300Hz handshake. Always place the 2225Hz handshake tone first for line cards accepting SIA DCS format.
2. Some Contact ID communicators respond to the 1400Hz handshake followed by the 2300Hz handshake instead of the dual tone 1400-2300Hz handshake (NAPCO Gemini communicators have been known to do this). Line cards accepting Contact ID should not have the 1400Hz followed by the 2300Hz before the dual tone 1400-2300Hz handshake.
3. SIA DCS communicators will respond to the Modem II and IIe handshakes. If a line card is to accept both SIA DCS and Modem II or IIe, the 2225Hz handshake must come before the Modem II and Modem IIe handshakes.
4. Some Westec panels will respond to the Modem II handshake. If a line card is to accept both Westec and Modem II formats, the Westec handshake must come before the Modem II handshake.
5. Some ITI panels don't respond to the default 2225Hz handshake. They need a lot longer handshake duration than what the 9500 receiver is defaulted as. You don't want to change the default 2225Hz handshake (1st handshake group) because it's optimized for SIA panels. What you should do is to program the 2nd 2225Hz handshake group with a long handshake duration (say 2550 ms). This way, a SIA panel responds to the 1st 2225Hz handshake and ITI panels respond to the 2nd 2225Hz handshake.

5.5.2.1 Edit Line Card Menu Options

From the Edit Line menu option, you can make changes to line card setting such as handshake sequence, pulse format, and listen-in mode. Table 5-9 describes line card edit options.

Table 5-9: Edit Line Card Menu Options

Line Card Menu	Choice	Choice	Choice	Default	Comments	
Edit Line	Handshake Sequence	Sequence Number	1 to 6	See Table 5-10	The order in which the line card will output different handshakes. Number 1 is sent first and number 6 is sent last. See page 5-37.	
		Format Group	2225 Hz 2300 Hz 1400 Hz 1400_2300Hz Westec Modem Iie Modem II Reserved 1400_2300-2 Not Used	Defaults apply only in relation to each Sequence Number	Handshake type. See page 5-37	
		HS Duration*			Length of time the receiver will send a handshake tone. See page 5-38.	
		Max Wait†	9810: 0 to 250 msec 9815: 0 to 9999 msec		Length of time the receiver will wait for data from the reporting panel before sending the next handshake tone. See page 5-39	
		Ack Duration*			Length of time the receiver will send an acknowledgement tone to the reporting panel. See page 5-39	
	Pulse Format	5-digit Format	4/1		✓	If a pulse comes in a 5-digit format the data is treated as the selected format.
			3/2			
			3/1CS			3 by 1 w/Check sum
		6-digit Format	4/2		✓	If a pulse comes in a 6-digit format then the data will then be treated as the selected format.
			3/2CS			3 by 2 w/Check sum
			4/1CS			4 by 1 w/Check sum
		Timeout (Inter-digit Tm [ms])	300 ms to 2 Sec.			This feature selects the time period between data blocks. If 0000 is selected then the receiver will use an automatic algorithm.
		Ack/Even (Ack on Even Round)	Yes			
	No			✓		
	Part (Partially Extended)	Yes		✓		Select this option if you have multiple extended data blocks for 3/1 or 4/1 formats.
No						

* Each numeric option is 10 times the displayed value. Example—064 X 10 = 640 msec.

† Each numeric option is 50 times the displayed value. Example—004 X 50 = 200 msec.

Table 5-9: Edit Line Card Menu Options

Line Card Menu	Choice	Choice	Choice	Default	Comments		
Edit Line (cont.)	Line Options	Direct	Y (Yes)		Y = dedicated or direct connect phone line. N = used for standard phone lines. See page 5-41 for more information.		
			No (No)	✓			
		Number of Rings	000-255	002	Number of rings the line card needs to receive before it will answer a call. It is recommended that number of rings is not set higher than 005. If Caller ID is turned on, set to 002 (see section 5.5.2.8 for more information on the Caller ID option). See page 5-42 for more information on Number of Rings.		
					On time	1-255 in 50ms periods	010 (500ms)
		Off time	1-255 in 50ms periods	010 (500ms)	9810 line card only. See page 5-43 for more information.		
		dB Level	Lo (Low) Hi (High) Md (Medium)	Lo (Low)	✓	9810 line card only. Select the db level of the handshake and acknowledge tones.	
				Hi (High)			
				Md (Medium)			
		Country Code	See page 5-44 for detailed list	USA	9815 line card only. Some Country Code selections support multiple countries. See page 5-44 for detailed list.		
		Threshold	1-15 in 2.0 VDC steps	08 (16.0VDC)	See page 5-45.		
	Fault Detect (Sample)	0-255 sec - 9810 0-90 sec - 9815	020 (20 Sec)	See page 5-45.			
	Listen In	Listen Mode	Not Used Common PBX	Not Used	✓	See page 5-46 for more information. Must not be used in UL installations.	
				Common			
				PBX	PBX edit string		
		Account List	Add Edit Clear Account	Add	Add up to 20 accounts. See page 5-49.		
				Edit	See page 5-49.		
				Clear Account	See page 5-49.		
		PBX String edit		None	Only available if PBX is selected in Listen Mode. See page 5-47.		
		Timeout	0-255	0	See page 5-48.		
		Account List	Add Account Edit Account Clear Account	Add Account	None	See page 5-48.	
				Edit Account			
	Clear Account						
	Trap List	Add Account Edit Account Clear Account	Enter Account # Choose Account Choose Account	None	See page 5-50 through page 5-51.		
Edit Account							
Clear Account							

Table 5-9: Edit Line Card Menu Options

Line Card Menu	Choice	Choice	Choice	Default	Comments
Edit Line (cont.)	Misc. Line Options	Echo Suppress	Y (Yes)		Outputs a 2 second 2025 Hz tone to disable echo suppression equipment that may interfere with modem formats. See page 5-52.
			N (No)	✓	
		Caller ID	Yes	✓	The Caller ID information will only be sent on incoming call messages that contain no data. If the call message contains any data (valid or invalid) no Caller Id information will be output. See page 5-52.
			No		
		Billing Delay	Y (Yes)		Initiates a 2 second delay at the start of each call before the handshake delay.
			N (No)	✓	See page 5-52 for more information.
		Hunt Group	00-99	00	Allows multiple line cards to report under the same group number to the automation software. See page 5-53.
		Ring Options	Min Ring	30 ms	9815 line card only. See page 5-53.
			Max Ring	060 ms	
			Ring Off	4000 ms	
			Min Ring Off	450 ms	
			Ring Off Error	2200 ms	
	Min # Rings Period	05			
	Call Hang Up			Max number of seconds the line card will stay off hook for a call. Helps prevent a run away panel from monopolizing the phone line.	
	Ademco Auto Opt.	BFSK AutoOut	H/S	✓	Used to setup communication with a automation system using ADEMCO 685 or CAPS. See Section 5.5.2.9.
			4/2		
		3/1 Restore Out	3/1	✓	
			H/S		
		4/2 Auto Out	H/S	✓	
			Nor		
FBI Printer Out		S/Fast	✓		
		LAR300			
Pulse Extended		Ext	✓		
		No Ext			
Extend Out	H/S	✓			
	4/2				

Table 5-9: Edit Line Card Menu Options

Line Card Menu	Choice	Choice	Choice	Default	Comments
Edit Device (cont.)	ITI Options Menu	ITI SCode Menu	Default SCode	12345	Used in communication locking on ITI panels.
			Add Acct/SCode	None	See Section 5.4.2.5 and 5.5.2.10.
			Edit Acct/SCode	None	
			Clear Acct/SCode	None	
			Add SCode Table	None	
			Clear SCode Table	None	
		Date/Time Flag	Requested	✓	
			Always		
		ITI 300 Baud	Yes	✓	If enabled, the receiver attempts to negotiate 300 baud communication with ITI panels that support 300 baud. See Section 5.5.2.10.
			No		
		Audio Mode	Instant	✓	Select the type of listen in that will be performed for ITI control panels. See Section 5.5.2.10.
			One Ring		
	Dial Back				
	Line Gain Opt	Transmit Gain	-3 to 14 dB	8 dB	9815 line card only. Sets line transmit and line receive gain. See Section 5.5.2.11.
		Receive Gain	0 to 12 db	6 dB	
		CID Monitor	Norm, Prearm, DTMF, or Marks	Norm	These options only apply if the Caller ID option is used. See Section 5.5.2.11 for information on the Line Gain Options and page 5-52 for information on the Caller ID option.
		CID Gain	-6 to 7 dB	7 dB	
		On Hook Gain	2 to 7 dB	7 dB	
		Ringer Imped	HI or SY	HI	

5.5.2.2 To Enter the Edit Line Card Option

To edit an existing line card follow these steps:

1. Log on to the receiver. (See Section 4.4.4 for log on procedure.)



2. Press  .

3. Press  to display the Program Menu.

The display will briefly show Initializing

Please wait . . .



4. Press  to choose Line Device Menu.

5. Press  or  to select the line card model you want to edit. Only installed models are displayed in the Select Device Type list (9810 and/or 9815).

6. When the equal sign highlights the model you wish to edit, press  .

7. Press  to edit the line card.

The display will show a list of installed line cards.

8. Press  or  to move through the available list.

9. When the equal sign highlights the line card you wish to edit, press  .

The display will show a list of choices. Table 5-9 lists these choices and provides a description of the options.

5.5.2.3 Handshake Sequence

Each line card is intelligent enough to determine what format is being sent from a reporting panel. You only need to program the handshake order and parameters for each line card (Figure 5-11). A line card will initiate up to four different types of handshake tone groups. The order in which the receiver sends out these handshake signals can be changed in this program location for each line card. Table 6-1 in Section 6 lists the proper handshake to use for the type of communication format you are using with a panel.



Figure 5-11 Handshake Sequence Menu

About the Handshake Sequence

The handshake sequence sets the order in which the receiver will send out handshakes. The default settings for each handshake sequence number is shown in Table 5-10. See Table 5-9 for ranges. The following sections describe how to change the handshake order and the parameters associated with the handshake.

Table 5-10: Handshake Format Group Default Settings by Line Card Model





Line Card Model	Seq #	Handshake Group	Handshake Duration*	Max Wait†	Acknowledge Duration*
9810	1	2225 Hz	090	064	075
	2	1400_2300-2	010	010	080
	3	2300 Hz	100	064	100
	4	1400 Hz	100	064	100
	5	Westec	063	064	026
	6	ModemII	100	064	075
9815	1	2225 Hz	0900	3200	0750
	2	1400_2300-2	0100	1250	0800
	3	2300 Hz	1000	3200	1000
	4	1400 Hz	0630	3200	1000
	5	Westec	0630	3200	0260
	6	ModemII	064	3200	0600

Notes below apply to the 9810 line card only. 9815 line cards display the actual time in msec.







* Each numeric option is 10 times the displayed value. Example—064 X 10 = 640 msec.

† Each numeric option is 50 times the displayed value in the Max Wait field. Example—004 X 50 = 200 msec.

Change the Handshake Sequence Number







1. Follow the procedure in Section 5.5.2.2.
2. Press  for handshake sequence menu.
When display flashes on the Seq# (see Figure 5-11).
3. Press  or  to change the ordered handshake number.
1 = the first handshake tone sent 2 = the second handshake tone to be sent and so on.
4. When the desired sequence number is flashing press  or .
The display will start flashing the format group field.

Change the Format Group

1. Follow the procedure in Section 5.5.2.2.
2. Press  for handshake sequence menu.
3. Press  until the display flashes on the Format Group field.
4. Press  or  to change the format group. See Table 6-1 in Section 6 for your communication format.
5. When the desired format group is flashing press  or .





Change the Handshake Duration Time

The handshake duration is the length of time that the receiver will send a handshake tone. See Table 5-10 for valid entries for each line card model.

1. Follow the procedure in Section 5.5.2.2.
2. Press  for handshake sequence menu.
3. Press  until the display flashes on the Hs duration field.
4. Enter the desired value from the keypad or press  or  to change the handshake duration time.
5. When the desired handshake duration time is flashing press  or .



Change the Maximum Handshake Wait Time

The wait time is the amount of time the receiver will wait for data from the reporting panel before outputting the next handshake sequence. See Table 5-10 for valid entries.

1. Follow the procedure in Section 5.5.2.2.
2. Press **1** for handshake sequence menu.
3. Press  until the display flashes on the Max Wait field.
4. Enter the desired value from the keypad or press  or  to change the wait time.
5. When the desired wait time is flashing press  or .

Change the Acknowledgment Tone Duration Time





The acknowledgment tone duration time is the amount of time the receiver will send an acknowledgment tone to the reporting panel. See Table 5-10 for valid entries.

1. Follow the procedure in Section 5.5.2.2.
2. Press **1** for handshake sequence menu.
3. Press  until the display flashes on the Ack duration field.
4. Enter the desired value from the keypad or press  or  to change the acknowledgment tone duration time.







5.5.2.4 Pulse Format

Select how this line card will handle pulse formats.

Select Which Format a 5-digit Pulse Format will be Received As







1. Follow the procedure in Section 5.5.2.2.
2. Press **2** for pulse format menu.
3. Press  until the display flashes on the 5-digit Fmt field.
4. Select the format by pressing  or .
5. When the desired wait time is flashing press  or .

Select Which Format a 6-digit Pulse Format will be Received As







1. Follow the procedure in Section 5.5.2.2.
2. Press  for pulse format menu.
3. Press  until the display flashes on the 6-digit Pulse Fmt field.
4. Select the format by pressing  or .
5. When the desired wait time is flashing press  or .

Select the Inter-Digit





This option adjust the time period between data blocks that the receiver will tolerate.

1. Follow the procedure in Section 5.5.2.2.
2. Press  for pulse format menu.
3. Press  until the display flashes on the Inter-digit field.
4. Enter the desired value from the keypad or press  or .
5. When the desired wait time is flashing press  or .

Set for 2300 and 1400 formats that Require Acknowledges on Even Rounds

1. Follow the procedure in Section 5.5.2.2.
2. Press  for pulse format menu.
3. Press  until the display flashes on the Ack on Even Round field.
4. Select the format by pressing  or .
5. When the desired wait time is flashing press  or .

Set for 3/1 and 4/1 Partially Extended Formats

1. Follow the procedure in Section 5.5.2.2.
2. Press **2** for pulse format menu.
3. Press  until the display flashes on the Partially Extended field.
4. Select the format by pressing  or .
5. When the desired wait time is flashing press  or .

5.5.2.5 Line Options





Line options is used to set options such as the type of phone line, number of rings, ring on/off duration, threshold voltage, and sample time. Not all options are available with both line card models (9810 and 9815). Options that only apply to one card are noted in the procedure heading.

Note:
The 9815 line card is shown in this example. Some of the 9810 numeric options are slightly different







Figure 5-12 Line Options Menu

How to Set the Line Card for a Direct Line (Dedicated Line):

1. Follow the procedure in Section 5.5.2.2.
2. Press **3** for Line Options menu.
3. The display will flash on the Direct Cnct field.
4. Press  or  to toggle between Y for Yes, or N for No.
5. When the desired setting is flashing press  or .

To Change the Number of Rings Follow These Steps:





This controls the number of rings the receiver needs to see before it will answer the call.

1. Follow the procedure in Section 5.5.2.2.
2. Press **3** for Line Options menu.
3. The display will flash on the Number of Rings field.
4. Enter the desired value from the keypad (0-255) or press  or  to change the number of rings before the receiver will answer.
5. When the desired number of rings is flashing press  or .

Note: If Caller ID (see Section 5.5.2.8) is turned on the number of rings must be set to 2.







To Change the Ring On Time (9810 only):

The “On” field controls the ring on time on 9810 line cards only. The ring on time is the length of time the receiver will listen to a ring prior to recognizing it as a ring.

1. Follow the procedure in Section 5.5.2.2.
2. Press **3** for Line Options menu.
3. Press  until the display flashes on the On Time field.
4. Enter the desired value from the keypad or press  or  to change the ring on time. Values range from 0 to 255 in increments of 50ms (1=50ms, 2=100ms, 3=150ms and so on).
5. When the desired ring on time is flashing press  or .

To Change the Ring Off Time (9810 only):

The “Off” field controls the ring off time on 9810 line cards only. The ring off time is the length of time the receiver will recognize an “Off” ring voltage.







1. Follow the procedure in Section 5.5.2.2.
2. Press  for Line Options menu.
3. Press  until the display flashes on the Off Time field.
4. Enter the desired value from the keypad or press  or  to change the ring off time. Values range from 0 to 255 in increments of 50ms (1=50ms, 2=100ms, 3=150ms and so on).
5. When the desired ring off time is flashing press  or  .

To Change the Country Code (9815 only):

To Country Code field identifies the phone system to which the receiver is connected. Some Country Code options support multiple countries as shown below. Select the appropriate Country Code for your phone system.





Table 5-11: Country Code Options

Option	Support Countries
USA	Argentina, Bahrain, Canada, Chile, Columbia, Ecuador, El Salvador, Guam, Hong Kong, Hungary, India, Kuwait, Macao, Mexico, Oman, Saudi Arabia, Singapore, UAE, USA, Yemen
CTR21	Austria, Belgium, Cyprus, Denmark, Finland, France, Germany, Greece, Iceland, Ireland, Israel, Italy, Liechtenstein, Luxembourg, Netherlands, Norway, Portugal, Spain, Sweden, Switzerland, United Kingdom
Australia	Australia
Brazil	Brazil, China, Japan, Jordan, Malaysia, Pakistan, Taiwan
Bulgaria	Bulgaria, Czech Republic, New Zealand, Slovakia, Slovenia
Latvia	Latvia
Nigeria	Nigeria
Philippines	Philippines
Poland	Poland
South Africa	South Africa
South Korea	South Korea

1. Follow the procedure in Section 5.5.2.2.
2. Press  for Line Options menu.
3. Press  until the display flashes on the Country Code field.
4. Press  or  to change the Country Code.
5. Press  or .







To Change the Ring Threshold Voltage:

The Threshold field controls the phone line low voltage/Line Fault threshold level. If the voltage on the phone line connected to the line card drops below this set threshold level for that line card, the receiver will indicate a Line Fault on that phone line.

1. Follow the procedure in Section 5.5.2.2.
2. Press **3** for Line Options menu.
3. Press  until the display flashes on the Threshold field.
4. Enter the desired value from the keypad or press  or  to change the Line fault threshold level. Values range from 1 to 15 volts in 2.0 VDC increments (0=line monitor disabled, 1=2.0VDC, 2=4.0VDC, 3=6.0VDC and so on).
5. When the desired line fault threshold is flashing press  or .

To Change the Phone Line Fault Detection (Sample Rate):

The Fault Detect field controls how often the receiver will sample the phone line to verify that it is above the set threshold level of that line card. This is how often the receiver verifies the integrity of the phone line.

1. Follow the procedure in Section 5.5.2.2.
2. Press **3** for Line Options menu.
3. Press  until the display flashes on the Fault Detect field.
4. Enter the desired value from the keypad or press  or  to change the line sample rate. For the 9810, values range from 0 to 255 in 1 second increments (1=1 second, 2=2 seconds, 3=3 seconds and so on). For the 9815, values ranging from 0 to 90 seconds in 1 second increments. The receiver will make two to three samples before generating a trouble condition on a faulty line.
5. When the desired sample time is flashing press  or .
6. Press  to exit this menu.

5.5.2.6 Listen-In

Note: See Section 2.3.2 for UL requirement on listen-in.

The listen in feature is used to perform two-way voice alarm verification between the central station and the alarm installation site.

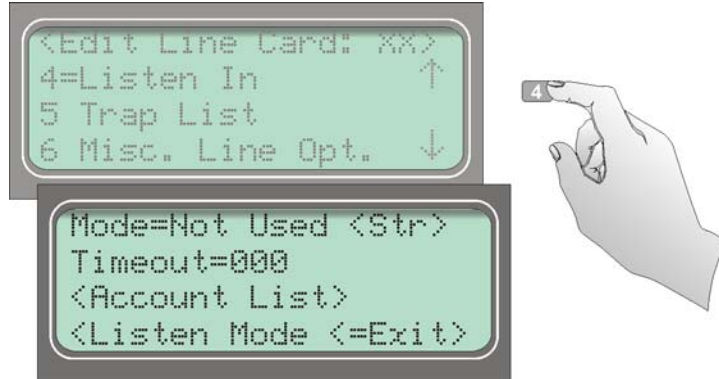





Figure 5-13 Listen Mode Menu Display

To Change the Listen Mode:

1. Follow the procedure in Section 5.5.2.2.
2. Press **4** for the listen in options menu.
3. When the display shows the listen in options menu (see Figure 5-13):

Press  or  to change the listen mode setting.

4. When the desired setting is flashing press  .

To Change the PBX String:

This option only appears if PBX is select as the mode.







1. Follow the procedure in Section 5.5.2.2.
2. Press  for Listen In options menu.
3. Press  until the display flashes on the <Str> field.
4. Press .
5. Enter the desired numeric value from the keypad or press  or  to enter any special characters.



Table 5-12: Valid Programmable String Characters

Character	Description
F	Flash hook.
P	Delay 500ms
,	Delay 2 seconds
H	Force a hang up of the line.
@	Detect dial tone.
t	Check to see if the line is busy by looking for a busy tone.
0-9, *, #, A, B, C, D	DTMF digits.

6. Press  to move to the next character.

or

7. Press  to enter the PBX string.

8. Select Y or N by pressing  or .

Y = Yes, erase or clear the PBX string. N = No, do not clear the PBX string, save the entered value.

Note: If Yes is selected the PBX string will be cleared and the "Clear String" option will revert to N (No).

To Change the Listen-In Timeout:

Timeout is the amount of time Listen-in will remain active before timing out.

1. Follow the procedure in Section 5.5.2.2.
2. Press **4** for Listen In options menu.
3. Press **▶** until the display flashes on the <Timeout> field.
4. Enter the desired value from the keypad or press **▲** or **▼** to change the timeout setting. Values range from 0 to 255 in 1 second increments.
5. When the desired value is flashing press **ENTER MENU**.

To Edit the Listen-In Accounts Lists:

1. Follow the procedure in Section 5.5.2.2.
2. Press **4** for Listen In options menu.
3. Press **▶** until the display flashes on the <Account List> field.
4. Press **ENTER MENU**.

The Figure 5-14 shows the next display.

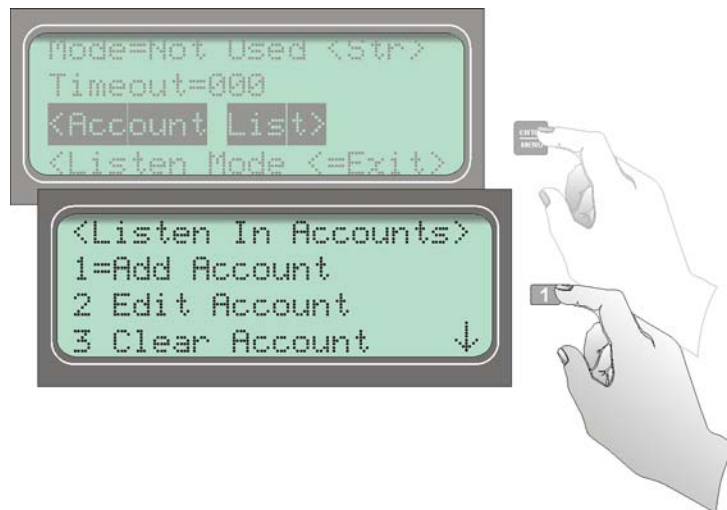

Figure 5-14 Listen In Accounts Menu

To Add a Listen In Account

5. Press .

The display briefly shows the number (indicated by **XX**) of the lowest available listen in account number slot (20 total listen in account numbers). Adding # **XX**

6. Enter the account number you wish to add to the listen in account list.



7. When the desired account number is flashing press .

Table 5-13: Account Characters

Characters	Description
0-9	Numeric entries
A-Z	Alpha entries
*	Alpha-numeric wild card entry. Example: 123* = any account starting with 123.
#	Numeric wild card entry. Example: # = 0 to 9. Example: 12345# = 123450 to 123459.

To Edit a Listen In Account

8. Press .

9. Press  or  until the desired listen in account is highlighted by the equal sign.

10. Press .



11. Enter the revised account number you wish to the account list. See Table 5-13.

12. Press .

Note: When editing an existing account it must be completely re-entered.

To Clear a Listen In Account

13. Press .

14. Press  or  until the desired listen in account is highlighted by the equal sign.

15. Press .

The Display will read: < WARNING! >
Delete Record No

16. Press  or  to toggle to Yes.

17. Press .

5.5.2.7 Trap List

The trap list is used to trap an account that you wish to route to a downloading computer for initial or additional programming.





To Add a Trap Account

1. Follow the procedure in Section 5.5.2.2.
2. Press **5** for Trap List menu.
3. Press **1**.



The display briefly shows the number (indicated by **XX**) of the lowest available trap account number slot (20 total trap account numbers). Adding # **XX**

4. Enter the account number you wish to add to the trap account list. See Table 5-13.
5. When the desired account number is flashing press .

To Edit a Trap Account

1. Follow the procedure in Section 5.5.2.2.
2. Press **5** for Trap Lists menu.
3. Press **2**.
4. Press  or  until the desired trap account is highlighted by the equal sign.
5. Press .
6. Enter the account number you wish to add to the trap account list. See Table 5-13.
7. Press .

To Clear a Trap Account

1. Follow the procedure in Section 5.5.2.2.
2. Press **5** for Trap List menu.
3. Press **3**.
4. Press  or  until the desired listen in account is highlighted by the equal sign.
5. Press .

The Display will read: < WARNING! >
 Delete Record No

6. Press  or  to toggle to Yes.

Note: Additional presses of the up or down arrow will toggle the choice between “yes” and “No”.

7. Press .

5.5.2.8 Misc. Line Opt.

Some phone lines may use miscellaneous line options such as echo suppression, a billing delay feature, or a hunt group. These miscellaneous phone options can be set through this programming menu.



Note:
The 9815 line card is shown in this example. Some of the 9810 numeric options are slightly different



Figure 5-15 Miscellaneous Phone Line Options

To Change the Echo Suppress Setting:





If echo suppression is enabled (Y) a 2025Hz signal will be output for two seconds to disable echo suppression equipment. This option should be used only for panels that require a 2225Hz handshake.

1. Follow the procedure in Section 5.5.2.2.
2. Press **6** for Miscellaneous Line Options menu (see Figure 5-15).
The display Flashes on the Echo Suppress= field.
3. Press  or  to change the echo suppress option from Y (Yes) to N (No) or vice versa.
4. When the setting is flashing press .

How to Set Caller ID





Caller Id information is only sent if the incoming call has no data contained in it.

Note: If the incoming message contains any data (valid or invalid) no Caller ID information will be sent.





1. Follow the procedure in Section 5.5.2.2.
2. Press **6** for Miscellaneous Line Options menu (see Figure 5-15).
The display Flashes on the Echo Suppress= field.
3. Press  until the display flashes on the Caller ID field.
4. Press  or  to change the caller ID option from Y (Yes) to N (No) or vice versa.
5. When the setting is flashing press .

To Change the Billing Delay Setting:

If billing delay is enabled (Y), a delay of two seconds will be inserted at the beginning of each incoming call.

1. Follow the procedure in Section 5.5.2.2.
2. Press **6** for Miscellaneous Line Options menu.
3. Press  until the display flashes on the Billing Delay field.
4. Press  or  to toggle the billing delay between “Yes” or “No”.
5. When the desired setting is flashing press .

To Change the Hunt Group:

1. Follow the procedure in Section 5.5.2.2.
2. Press **6** for Miscellaneous Line Options menu.
3. Press  until the display flashes on the HntGrp field.
4. Enter the desired value from the keypad or press  or  to change the hunt group number.
5. When the desired hunt group is flashing press .
6. To exit press .

To Change the Ring Options (9815 only)





Use Ring Option settings to control when the line card answers an incoming call. To review the Ring Option settings see Table 5-14.

Note: The default ring options will function for most installations and will not need to be changed.

Table 5-14: Ring Options





Choice	Default	Comments
Min Ring 15-99 ms	30	Minimum ringer frequency that is accepted as valid.
Max Ring 015 to 100 ms	060	Maximum ringer frequency that is accepted as a valid.
Ring Off 1500 to 8000 ms	4000	This value is the normal amount of time between rings on the local phone system. If the value entered in this field is too large for your local phone system, it may cause the system to miss the beginning of Caller ID information.
Min Ring Off 100 to 800 ms	450	Caller ID information is normally sent between the first and second ring. On some phone systems the first ring is sent in 2 bursts with a short pause in between. For proper handling of caller ID the system needs to be able to determine that these 2 bursts are one ring. The Minimum Ringer Off Time is used to determine what the minimum interval is between rings so that the system will treat two burst separated by a brief pause as one ring.
Ring Off Error 0800 to 4400 ms	2200	An amount of time added to the Ringer Off Time and Min Ring Off options when determining if a ring is a new call. When the length of time since the last ring exceeds this sum, the ring is handled as a new call.
Min # Rings Period 01 to 20	05	The number of valid rings that must be received before the system answers a call.

To set ring options:

1. Follow the procedure in Section 5.5.2.2.
2. Press  for Miscellaneous Line Options menu.
3. Press  until the display flashes on the RingOptions field.
4. Press .
5. Make the desired changes using the arrow keys to navigate and select values.
6. To exit press .





To Change Call Hang Up Settings

Use Call Hang Up setting to control how long the receiver will hold the line before hanging up after a call has ended. See Table 5-10 for more information.

1. Follow the procedure in Section 5.5.2.2.
2. Press  for Miscellaneous Line Options menu.
3. Press  until the display flashes on the CallHangUp field.
4. Enter the desired value from the keypad or press  or  to change the setting.
5. To exit press .

5.5.2.9 Ademco Auto Opt

Used to set up communication with a automation system using Ademco automation protocols.

1. Follow the procedure in Section 5.5.2.2.
2. Press **7** for Ademco Automation Options menu.
3. Press  until the display flashes on the desired field.
4. Enter the desired value from the keypad or press  or  to change the setting.
5. Press .
6. Repeat steps 3 and 4 for each option.
7. To exit press .

5.5.2.10 ITI Options Menu

In this programming location settings particular to an ITI control panel can be set, such as security codes (SCode), date and time setting, and 300 baud negotiation. See Table 5-15 for more information on the ITI Options menu.



Figure 5-16 ITI Options Menu

Table 5-15: ITI Options Menu Items

ITI Options Menu	Choice	Valid Entry	Comments
ITI SCode Menu	Default SCode		00000 to 99999 This set the default security code for this line card. Additional security codes can be added to the SCode table (see below).
	Add Acct/SCode (up to 20 entries)	Enter control panel 5-digit account No.	00000 to 99999 Enter the 5-digit account number of the ITI control panel that the receiver will be looking for on this line card.
		Set or Clear Security Code.	Clear or Set Clear old security code and set to default security code. (See Default SCode above.) If set is chosen an additional menu will appear that allows you to enter the security code you wish to set the panel to.
		Security Code	00000 to 99999 (Appears only if Set is previously chosen) Note: If the security code entered here is not presently in the SCode table (see below), it will automatically be entered once the line card has successfully communicated with that account.
	Edit Acct/SCode	1 to 20	Same as Add Acct/SCode Edit an account previously programmed into Add Acct/SCode table.
	Clear Acct/SCode		1 to 20 Remove an account that was previously programmed into Add Acct/SCode table.
	Add SCode Table (up to 20)		00000 to 99999 Adds a new security code to the security code table.
	Clear Scode Table		1 to 20 Removes an security code from the SCode table.
Date/Time Flag	Requested		The date and time programmed into an ITI control panel will only be updated by the receiver if the control panel requests it.
	Always		The date and time programmed into an ITI control panel will be updated by the receiver automatically every time the control panel calls into the receiver.
ITI 300 Baud	Yes		If enabled, the receiver will attempt to negotiate 300 baud communication with ITI panels that support 300 baud communication. See 5.5.2.8 for programming steps.
	No		
Audio Mode	Instant		ITI controls that have listen in initialized will preform listen in instantly when the control calls the central station.
	One Ring		ITI controls that have listen in initialized will preform listen in after one ring when the control is called, after the control calls the central station.
	Dial Back		ITI controls that have listen in initialized will call a programmed phone number after the control calls the central station.

ITI SCode Menu:

Some ITI control panels use one of two types of communication locks (phone lock or a central station lock). On the panels using a central station lock, a security code is required during communication. In this programming location a 5-digit central station lock security code can be set.

1. Follow the procedure in Section 5.5.2.2.
2. Press **6** for ITI options menu.

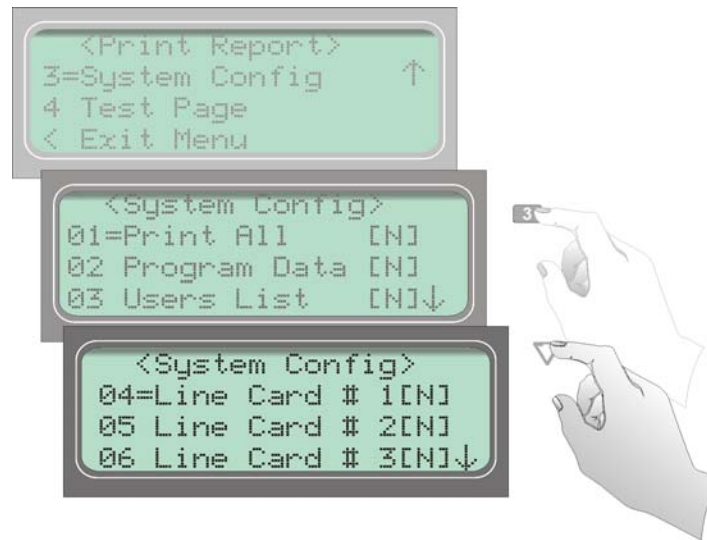









Figure 5-17 ITI SCode Menu

3. Press **1** for ITI SCode (security code) menu.
Choose the desired option (refer to Table 5-15).
4. Press **ENTER MENU**.
5. Enter the necessary field information (see Table 5-15).





To Set Date/Time Flag:

1. Follow the procedure in Section 5.5.2.2.
2. Press **6** for ITI options menu.
3. Press **2** for date/time flag menu.
4. Press  or  to toggle between Requested or Always. See Table 5-15 for description.
5. When the desired setting is flashing press . To exit press .

To Enable or Disable ITI 300 Baud Negotiation:

1. Follow the procedure in Section 5.5.2.2.
2. Press **6** for ITI options menu.
3. Press **3** for ITI options menu.
4. Press  or  to toggle between Yes or No. See Table 5-15 for description.
5. When the desired setting is flashing press . To exit press .

Set the Type of Listen-In Used for ITI Controls:

1. Follow the procedure in Section 5.5.2.2.
2. Press **7** for ITI options menu.
3. Press **4** for Audio Mode menu.
4. Press  or  to select the desired setting. See Table 5-15 for description.
5. When the desired setting is flashing press . To exit press .

5.5.2.11 Line Gain Options Menu (9815 only)

The Line Gain Options menu let you set parameters for a 9815 line card.



Figure 5-18 Line Gain Options Menu

Changing the Transmit and Receive Gain

1. Follow the procedure in Section 5.5.2.2.
2. Press **9** for the Line Gain Options menu (see Figure 5-18).

The display Flashes on the `Xmit=` to change the transmit gain or the `Rec=` field to change the transmit receive gain.





3. Press **▲** or **▼** to change the transmit gain option.
4. When the setting is flashing press **ENTER MENU**.

Changing the Caller ID (CID) Monitor

Caller ID Monitor allows you to select from the following decoding modes:

- Normal (standard) – The detection method is first ring, delay, preamble, marks, and then Caller ID data. Normal is the default.
- Preamble – The Caller ID chip looks for preamble data prior to Caller ID.
- DTMF (non-standard) – The system looks for DTMF based Caller ID data.
- Marks – The Caller ID chip looks for a Marks signal prior to the Caller ID data.







Note: This option is only applicable when Caller ID has been selected (see page page 52).

1. Follow the procedure in Section 5.5.2.2.
2. Press  for the Line Gain Options menu.
3. Press  until the display flashes on the Mon= field.
4. Press  or  to change the CID option.
5. When the setting is flashing press .

Changing the Caller ID (CID) Gain and On Hook Gain

Caller ID Gain sets the gain of the Caller ID receive logic. On Hook Gain sets the analog receive Caller ID gain prior to line pickup.





Note: These options are only applicable when Caller ID has been selected (see page page 52).

1. Follow the procedure in Section 5.5.2.2.
2. Press  for the Line Gain Options menu.
3. To change the CID Gain option, press  until the display flashes on the Gain= field, or press  until the display flashes on the OHGain= field.
4. Press  or  to change the Gain option.
5. When the setting is flashing press .

Changing the Ringer Impedance

Ringer Impedance allows the impedance the Caller ID chip presents to the phone line to be set for either High or Synthesize.

Note: This option is only applicable when Caller ID has been selected (see page 52).

1. Follow the procedure in Section 5.5.2.2.
2. Press **9** for the Line Gain Options menu.
3. Press  until the display flashes on the RImp= field.
4. Press  or  to change the ring impedance option.
5. When the setting is flashing press .





5.5.3 Copy Devices

The Copy Device option lets you to program a line card to default factory settings established by Silent Knight or copy the programming of an existing line card.

5.5.3.1 To Program the Default Settings Into a Line Card

The Use Defaults option lets you program a line card to default factory settings established by Silent Knight.









Warning: *This procedure cannot be undone.*

1. Enter Program Mode (see Section 5.1).
2. Press **2** to choose Line Device Menu.
The display will show <Select Device Type>.
3. Press **1** if the line card is a 9810, and press **2** if the line card is a 9815. If you have only one line card model installed, only that model number will display.
4. Press **3** to select the Copy Device(s) menu.
5. Press **1** to select the Use Defaults menu.
6. Press  or  until the equal sign highlights the desired line card number.
7. Press the  button to toggle to 'Y' (yes) to program this line card to default values.
8. When all line cards you want program to factory defaults are chosen, press .

5.5.3.2 Copy the Programming of an Existing Line Card to Another

The Copy Existing option is a time saving feature that lets you copy the programming of one line card to one or more installed line cards.

Warning: This procedure cannot be undone.

1. Enter Program Mode (see Section 5.1).
2. Press **2** to choose Line Device Menu.
The display will show <Select Device Type>.
3. Press **1** if the line card is a 9810, and press **2** if the line card is a 9815. If you have only one line card model installed, only that model number will display.
4. Press **3** to select the Copy Device(s) menu.
5. Press **2** to select the Copy Existing menu.
6. Press  or  until the equal sign highlights the desired Source line card number.
7. Press .
8. Press  or  until the equal sign highlights the desired Target line card number.
9. Press the  button to toggle to 'Y' (yes) to copy this line card.
10. When all line cards you want copy are chosen, press .
11. Press .

5.5.4 Clear Device

You can use the Clear Device option to remove a line card from being seen by the receiver.

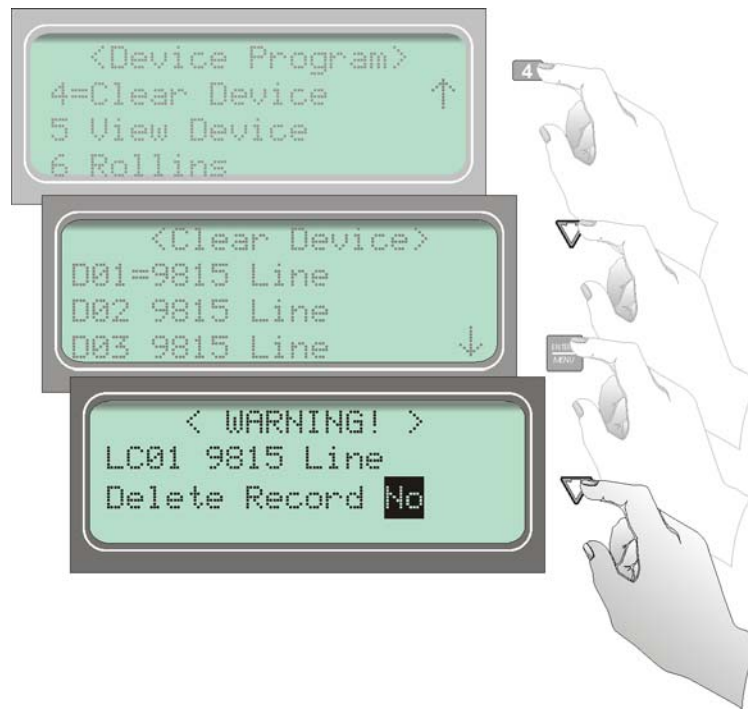





Figure 5-19 Steps to Clear a Line Card From the Receiver

To Clear or Delete a Line Card From the Receiver:

1. Enter Program Mode (see Section 5.1).
2. Press **2** to choose Line Device Menu.
The display will show <Select Device Type>.
3. Press **1** if the line card is a 9810, and press **2** if the line card is a 9815. If you have only one line card model installed, only that model number will display.
4. Press **4** to select the Clear Device menu.
5. Press **▽** until the desired line card is highlighted with an equal sign.
6. Press **ENTER MENU**.
The display will read <Warning!>
LC01 9815 Line
Delete Record No
7. Press **△** until Yes is flashing.
8. Press **ENTER MENU**, then press **◀** to exit.





5.5.5 View Device

To view all the line cards in the receiver follow these steps:

1. Enter Program Mode (see Section 5.1).
2. Press **2** to choose Line Device Menu.
The display will show <Select Device Type>.
3. Press **1** if the line card is a 9810, and press **2** if the line card is a 9815. If you have only one line card model installed, only that model number will display.
4. Press **5** to select the View Device menu.
5. Press **4** to view line cards.
6. When display shows the list of line cards, press  to scroll through the list of line cards to select the desired line card.
7. Press  to see device information, including part number and serial number.
8. To exit press .

5.5.6 Rollins

To set this line card to receive calls from Rollins control panels.

1. Enter Program Mode (see Section 5.1).
2. Press **2** to choose Line Device Menu.
The display will show <Select Device Type>.
3. Press **6** to select the Rollins menu. The display shows the list of line cards.
4. Press  or  until the equal sign highlights the desired line card number.
5. Press the  button to toggle to Y (yes) to copy this line card.
6. When all line cards for which you want to accept Rollins calls are chosen, press .

5.6 User List

The User List option is used to program and store the information on the installers and operators who will operate and maintain the receiver. From this option, you can add, edit, and clear (delete) installers and operators. The receiver supports up to 40 users. Each user is assigned a name, PIN (personal identification number), and a profile.

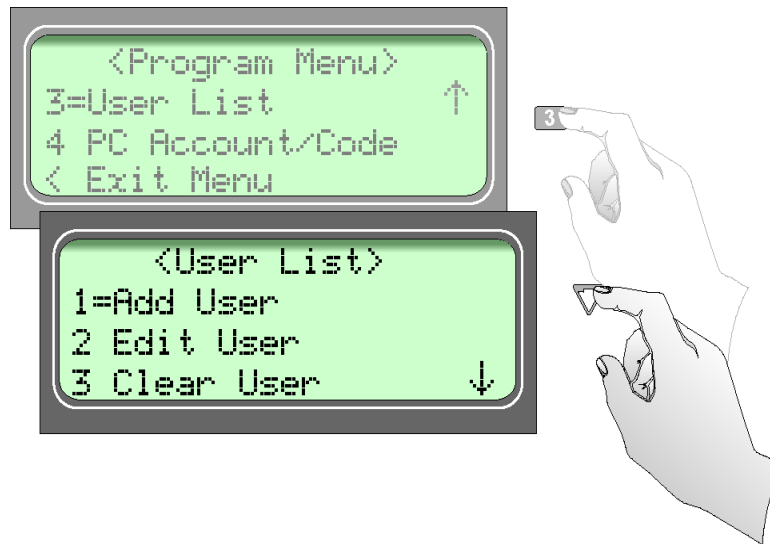

Figure 5-20 User List Menu Items

Table 5-16 lists the available choices under User List and provides a matrix of choices.

Table 5-16: User List Menu Items and Steps

Choice	Step 1	Step 2	Step 3	Comments
Add User	Enter user name: 1. Use the up or down arrow to move through characters. 2. Press the right arrow to move to next character slot. 3. Press enter key to move to next step.	Enter PIN code: 4 digits minimum 9 digits maximum	Choose profile level: Operator or Installer	Add user is used to add a new user to the system and enter the user's PIN and profile information.
Edit User	When "Choose User" list appears: 1. Press the down arrow key until the desired user is highlighted with the equal sign. 2. Press enter to move to next step.	Repeat Steps 1-3 under Add User.		Edit user is used to change an existing users profile.
Clear User	When "Choose User" list appears: 1. Press the down arrow key until the desired user is highlighted with the equal sign. 2. Press enter to move to clear user from profile list.			Clear user is used to delete a user from the receiver's memory.

5.6.1 Adding a User

Use the following steps to add a user to the system:

1. Enter Program Mode (see Section 5.1).
2. Press **3** to choose User List.
3. Press **1** to add a user.

The user number to be programmed will appear in the display for one second. This user number will always be the lowest available user number.



4. Press  or  to move through the available characters.





Table 5-17: Available Characters

Characters	Comments
Space, 0-9, !, -, _, =, %, &, *, #	The word "Space" indicates that a physical space would be inserted if this character were chosen.
A-Z	Upper case alphabetical characters
a-z	Lower case alphabetical characters

There are 16 characters available for each user name.

Note: If no characters are entered in the name field, the user name will default to "User #XX". XX = the number location of the user being programmed. For example, if user 12 location is being programmed and no name characters are entered in the name field, then that user will be named User #12.

When the desired character is flashing in the display:

5. Press the .
6. Repeat steps 6 and 7 until the user's name is complete.
7. Press .
8. Enter the desired 4 to 9 character user PIN code.
9. Press . The display will flash Operator.
10. Press  to toggle between Installer and Operator.
11. When the desired profile level is flashing press .

5.6.2 Editing a User



Use the following steps to edit an existing user:

1. Enter Program Mode (see Section 5.1).

2. Press **3** to choose User List.

3. Press **2** to edit a user.



A list of all the users will appear starting with the lowest user number.

4. Press  or  to move through the user list.

5. When the equal sign highlights the user you wish to edit, press .

6. If you **do not** want the user name changed, press .

Or

To change the user name, press  or  to move through the available characters.
(See Table 5-17 for list of available characters.)

7. When the name change is complete press .

8. If you **do not** want the PIN code changed, press .

Or

To change the PIN code enter the desired code (4 to 9 digits in length), then press .

The display will flash the current profile level.

9. Press  to toggle between Installer and Operator.

10. When the desired profile level is flashing press .



5.6.3 Clearing a User From the Receiver

You can remove a user from the receiver's memory at any time using the Clear User option. The Installer and Operator user's (01 and 02 in the user list) cannot be deleted from the receiver.



Use the following steps to clear or delete a user from the system:

1. Enter Program Mode (see Section 5.1).
2. Press **3** to choose User List.
3. Press **3** to clear (delete) a user.

A list of all the users will appear starting with the lowest user number.

4. Press  or  to move through the user list.
5. When the equal sign highlights the user you wish to clear press .

The display shows < WARNING ! >
Delete Record No

6. Press  or  to toggle the flashing display to Yes.
7. Press .

5.7 PC Account/Code

The PC Account/Code feature, as shown below, is for factory diagnostics and is not for use in the field by installers.



Section 6

Compatible Reporting Formats

This section lists all the reporting formats that are compatible with the 9500.

Table 6-1 shows the formats that the 9500 can decode, handshake frequency format group which accommodates that format (see Section 5.5 for line card programming). Each line card can decode every format listed below, however, a line card can be programmed to prioritize the handshake order in which that line card will communicate.

6.1 Formats By Communication Group.

Table 6-1 shows which formats fit under the general communication groups and the corresponding handshake frequency.

Table 6-1: Formats compatible with the 9500

Communication Group	Format Name	Description	Handshake Format Group
Tone Burst	SK 4+2	Sends a 4-digit account and a 2-digit alarm code up to four rounds.	1400 Hz
	Sescoa 3+1/Franklin 3+1	Sends a 3-digit account and a 1-digit alarm code up to four rounds in a tone burst format. Each digit can be programmed from (0-9). Because there is no standard, this format reports in codes only.	2300 Hz
	Radionics 3+1 Checksum	Sends a 3-digit account and a 1-digit alarm code and a checksum.	1400 or 2300 Hz
	SK 3+1/3+1 Extended	Sends a 3-digit account and a 1-digit alarm code up to four rounds (10-40pps). Each block of data (2 rounds). If a second block of data is sent, it will contain the extended information. The account number cannot have repetitive digits (333, 888, etc.).	1400 or 2300 Hz
	4+1/4+1 Extended	Sends a 4-digit account code and a 1-digit alarm code up to four rounds in a pulse format (10-40pps).	4/1 1400 or 4/1 2300 Hz
	Pulse 4+2	sends a 4-digit account code and a 2-digit alarm code.	1400 or 2300 Hz
DTMF	Ademco Contact ID	Dual Tone Multiple Frequency. The data is decoded into English account information.	1400_2300 Hz
	Ademco Super Fast,	Sends a 4-digit account code and a 2-digit alarm code up to 9 events per call.	
	Acron Touch Tone	Sends a 4-digit account code and a 1-digit alarm code. Will send a maximum of 8 events per call.	
	Ademco Express	Sends a 4-digit account code and a 2-digit alarm code with a checksum.	
	DTMF 4+2	Sends a 4-digit account code and a 2-digit alarm code with a checksum.	1400 or 2300 Hz
	FBI 4+3+1	Sends a 4-digit account code, a 3-digit zone code and a 1-digit event code.	
	Westec	Sends a 4-digit account code, a 3-digit Dealer code followed by the event code.	

Table 6-1: Formats compatible with the 9500

Communication Group	Format Name	Description	Handshake Format Group
FSK	SX-III, SX-IVA	Sends a 5-digit account code in a Bell 103 format with checksum. The data is decoded into English account information.	2225 Hz
	SX-IVB		
	ITI SX-V		
	ITI Commander		
	ITI RF Commander, Harbor Guard		
	ITI Commander 2000, LifeGard		
	ITI CareTaker+, SecurityPro 4000		
	ITI MeterMinder		
	ITI FonSafe, PhoneWatch		
	ITI UltraGard		
	SIA DCS (Digital Communication Standard)	The data is decoded into English account information.	
	SIA 2000 (pending approval)	The data is decoded into English account information.	
	BFSK	Sends a 3-digit account and a 1-digit alarm code, similar to 3+1 Extended format except the data is decoded into English account information.	1400 or 2300 Hz
	SK FSK, FSK 0, FSK 80	Sends a 4-digit account code and a 1 byte (8 bit) of zone status information. Sends a 2225 Hz mark Frequency and a 2025 Hz space frequency from the dialer. Repeats the data message for verification.	1400 or 2300 Hz
SKFSK I, FSK I, FSK 81	Sends a 4-digit account code and a 2-digit alarm code. Sends a 2225 Hz mark Frequency and a 2025 Hz space frequency from the dialer. verification is done with check xor and checksum. 1 to 8 events per call.	1400 or 2300 Hz	
FSK II, FSK 86	Sends a 6-digit account code with a 2-digit alarm type and 2-digit zone number. Sends a check xor and checksum. 1 to 8 events per call.	1400 Hz	
Modem II	Sends a 4-digit account code with multiple 2-digit event codes.	Modem II	
Modem IIe	Sends a 4-digit account code with multiple 2-digit event codes.	Modem IIe	

6.2 Format Numbers Used In Printer Output

In a printed report the format used by a calling panels is listed as a number, that number represents a particular format. Table 6-2 lists these numbers along with the corresponding format.

Table 6-2: Formats By Report Number

Format Number	Format Type	Format Number	Format Type
0	No Response	38	4/1 Extended
3	SIA 2000	40	Unknown Pulse
4	SIA DCS	41	4/2 Ademco/SK
9	ITI	43	4/2 Extended
10	ITI SX-III or SX-IVA	46	3/1 Radionics
11	ITI Pin Point 128	47	3/1 Radionics with checksum
12	ITI RF Commander	48	4/2 Radionics with checksum
13	ITI Protection One/UltraGard	50	Ademco Contact ID
14	ITI CareTaker Plus	51	Ademco Touch Tone
15	ITI SX-V	52	Acron Touch Tone 3-digit account
16	ITI Commander 2000	53	Westec Touch Tone
17	ITI Harbor Guard	54	Ademco Express
18	ITI Simon	55	SIA D1
19	ITI Vector	56	SIA D1 with checksum
20	ITI Hardwire Commander	57	Ademco DTMF 4/2 with checksum
21	ITI SX-V Special/Rollins	58	Ademco DTMF 4/1 with checksum
22	ITI Marsden	59	Acron Touch Tone 4 digit account.
23	ITI Network Security	60	BFSK
24	ITI Nutone	61	FSK0/FSK80
25	ITI SX-IVB	62	FSK1/FSK81
30	3/1 Pulse Tone	63	FSK2/FSK86
31	3/1 Franklin/Sescoa	64	FBI 4/3/1 with checksum
32	3/1 Ademco/SK	65	FBI 4/3/1
33	3/1 Extended	71	Westec W970
35	4/1 Pulse Tone	72	Westec W1000, W2000, W3000
36	4/1 Franklin/Sescoa	74	Modem II
37	4/1 Ademco/SK	75	Modem Iie

6.3 Using Contact ID Format

!WARNING!

If you are receiving Contact ID format on your 9500 receiver you must use SK Expanded automation protocol. The 9000 automation protocol does not support Contact ID reporting format.

Important!

Due to the increasing number of formats a single line can accept and the wide variety of manufacturer's specifications for handshake/acknowledgement tones required for their digital dialers to communicate, Silent Knight strongly recommends the following for handshake tone order.

Section 7

Troubleshooting & Maintenance

This section contains a list of possible error messages and a troubleshooting process for each.

7.1 Error Messages

Table 7-1 lists the error messages that are displayed on the LCD of the receiver as well as the message sent to the printer. There are two types of error messages that are displayed and printed, line card communication errors, and system event errors. Line card communication errors relate specifically to how the receiver communicated to an incoming call. System event errors relate specifically to the system and the performance of its peripheral devices such as the automation software, printers, etc. In Table 7-1, heading “LC Error” indicates that the error message was a line card communication error and “SYS Error” indicates any system event related error messages.

Table 7-1: Error Messages

LC Error	Sys Error	LCD Messages	Printer Message	Description	What to Do
✓		No Data Received	No Data Received	On an incoming call no data was sent to the receiver after the receiver gave its handshake tones.	Usually a wrong number.
✓		0 Length Block	0 Length Blk	One of the message blocks received contained no data.	Possibly a call with caller ID information but no data from a control panel.
✓		No Ack	No Ack	Receiver was unable to acknowledge the call.	Check the line card setup and retest the panel.
✓		Time Out	Time Out	The incoming call timed out and the phone line was released.	1. Retest Panel.
✓		Corrupted Data	Corrupted Data	Bad or corrupted data was sent to the receiver.	2. Replace panel.
✓		Illegal Specifier	Illegal Specifier	An error occurred in the look-up table for this call message.	3. Replace line card.
✓		Undefined Event	Undefined Event	The panel communicating to the receiver sent an event code that the receiver does not recognize.	Call Technical Support.
✓		Unsupported Event	Unsupported Event	The panel communicating to the receiver sent an event code that the receiver recognized but does not support.	
✓		Unsupported Format	Unsupported Fmt	The calling panel communicated in a format not supported by the receiver.	Program the panel to a different reporting format.

Table 7-1: Error Messages

LC Error	Sys Error	LCD Messages	Printer Message	Description	What to Do
✓		Communication Error	Communication Error, Panel Requested Re-send	There was a communication error between the panel and the receiver and the receiver asked the panel to re-send the message.	If it continues test the panel.
✓		Possible Incomplete	Possible Incomplete Call	The receiver missed information in the call sequence.	Retest the panel.
	✓	System Power Up	System Power Up	Indicated that the receiver powered up.	
	✓	Expander Trouble	Expander Trouble	Trouble with a device connected to the SBUS.	Check the connection of that device on the SBUS. If connection OK replace SBUS device (line cards and touchpads).
	✓	Expander Trbl Rst	Expander Trouble Restore	The trouble condition of a SBUS device was corrected.	
	✓	AC Trouble	AC Trouble	AC power failure.	Check AC outlet and AC power cord.
	✓	AC Trouble Rst	AC Trouble Restore	AC power was restored.	
	✓	Battery Low Restore	Battery Low Restore	The backup battery power supply trouble has been corrected.	Restores at 12VDC after a low battery condition.
	✓	Battery Low	Battery Low	The backup battery is checked continually every second. This message would be displayed if the backup battery were set to "Battery Bkp". See Section 5.4.4. Indicates a low battery when the voltage drops to 10.2 VDC or lower.	Check battery cables. If they are OK replace backup battery.
	✓	Local Program Begin	Local Program Begin User #	This message indicates the time a system "installer" entered program mode.	
	✓	Local Program End	Local Program End User #	This message indicates the time a system "installer" exited program mode.	
	✓	Local Program Fail	Local Program Fail User #	The receiver will stay in program mode for 15 minutes without any activity, then it will time out and go back to normal mode. This message indicates that an installer entered programming and did not exit programming before it timed out.	
	✓	Listen-in End	Listen-in End	A listen-in session completed	
	✓	Listen-in Begin	Listen-in Begin	A listen-in session started.	
	✓	System Date Changed	System Date Changed User #	An installer changed the system date.	
	✓	System Time Changed	System Time Changed User #	An installer changed the system time.	

Table 7-1: Error Messages

LC Error	Sys Error	LCD Messages	Printer Message	Description	What to Do
	✓	Msg Queue Full	Message Queue Full	Messages can be sent to automation computer, a printer or can be manually acknowledged. If one or more of these devices does not respond to messages being sent or manually acknowledged, the message queue will fill up. When the message queue is full the receiver will no longer accept incoming calls.	Verify that messages are acknowledged to any printers, automation software, and while in manual mode.
	✓	Msg Queue Full restore	Message Queue Full restore	Indicates that the message queue full error has been corrected.	
	✓	Main Computer Trbl	Main Computer Trouble	A communication problem exists between the automation software and the receiver.	Check cable connections. Verify that the port is configured properly.
	✓	Main Computer Rst	Main Computer Restore	The communication error between the receiver and the automation software has been corrected.	
	✓	Bkup Computer Trbl	Bkup Computer Trouble	A communication problem exists between the backup automation software and the receiver.	Check cable connections. Verify that the port is configured properly.
	✓	Bkup Computer Rst	Bkup Computer Restore	The communication error between the receiver and the backup automation software has been corrected.	
	✓	Main Prn Off Trbl	Main Printer Off Line	The port programmed as the primary printer port is off line.	Check cable connections. Verify that the port is configured properly. Check power to printer.
	✓	Main Prn Paper Out	Main Printer Paper Out	The port programmed as the primary printer port is out of paper.	Replace paper in printer.
	✓	Main Prn Restore	Main Printer Restore	The error on the primary printer has been corrected.	
	✓	Bkup Prn Off Trbl	Bkup Printer Off Line	The port programmed as the backup printer port is off line.	Check cable connections. Verify that the port is configured properly. Check power to printer.
	✓	Bkup Prn Paper Out	Bkup Printer Paper Out	The port programmed as the backup printer port is out of paper.	Replace paper in printer.
	✓	Bkup Prn Restore	Bkup Printer Restore	The error on the backup printer has been corrected.	
	✓	DC Input Low Rst	DC Input Low Restore	The backup DC power supply trouble has been corrected.	Restores at 12VDC after a low battery condition.

Table 7-1: Error Messages

LC Error	Sys Error	LCD Messages	Printer Message	Description	What to Do
	✓	DC Input Low	DC Input Low	The backup battery is checked continually every second. This message would be displayed if the backup battery setting were set to "DC Bkp". See Section 5.4.4. Indicates a low when the voltage drops to 10.2 VDC or lower.	Check the connection to the DC power supply. Verify the output from DC power supply.
	✓	Msg Que > Warning	Message Queue Warning	When the message queue reaches the programmed level mark, this message is given as a pre-warning to "Message Queue Full". See Section 5.4.5.1 to program the % level at which the receiver will indicate the warning.	Verify that messages are acknowledged to any printers, automation software, and while in manual mode.
	✓	Msg Que < Warning	Message Queue Warning Restore	This message is given when the message queue drops below the programmed level after a message queue warning indication has displayed. See Section 5.4.5.2 to program the % level.	
	✓	LC Run in ROM	Linecard Running ROM Code	The line card is not running the application code.	Replace the line card.
	✓	Line Fault	Line Fault	The phone line voltage has dropped below the threshold voltage as programmed. (See Section 5.5.2.5.)	Check phone line outlet and phone cord.
	✓	Line Fault Restore	Line Fault Restore	Phone line voltage has been restored to normal parameters.	
	✓	Line Card Deleted	Line Card Record Deleted	A line card has been deleted.	
	✓	Line Card Added	Line Card Record Added	A line card has been added.	
	✓	User Log In	User Log In: User #	A user has logged on to the receiver.	
	✓	User Log Out	User Log Out: User #	A user has logged off of the receiver.	

7.2 Troubleshooting Process

Before you call Technical Support you may be able to solve the problem yourself by following these procedures.

1. Verify that a problem exists.
2. Check Fault Status.

This can be done by pressing the



. If the system fault LED in on the display will read:



Press the down arrow to view fault messages.

3. Check the manual for suggestions or solutions.
4. Check connections.
5. Isolate the problem. Remove other devices that may be interfering.
6. Try swapping devices to isolate the problem.
7. Try to replace the problematic device.
8. Document the failures and the steps used to resolve them.

7.3 Replacing the 9500 Fuse

If the AC Power light is off or flashing and the 9500 has 120 VAC of power, check the 9500 fuse. If the fuse needs to be replaced, follow the steps below.

1. Remove power from the 9500.
2. Locate the fuse cap on the back of the 9500 as shown in Figure 7-1.

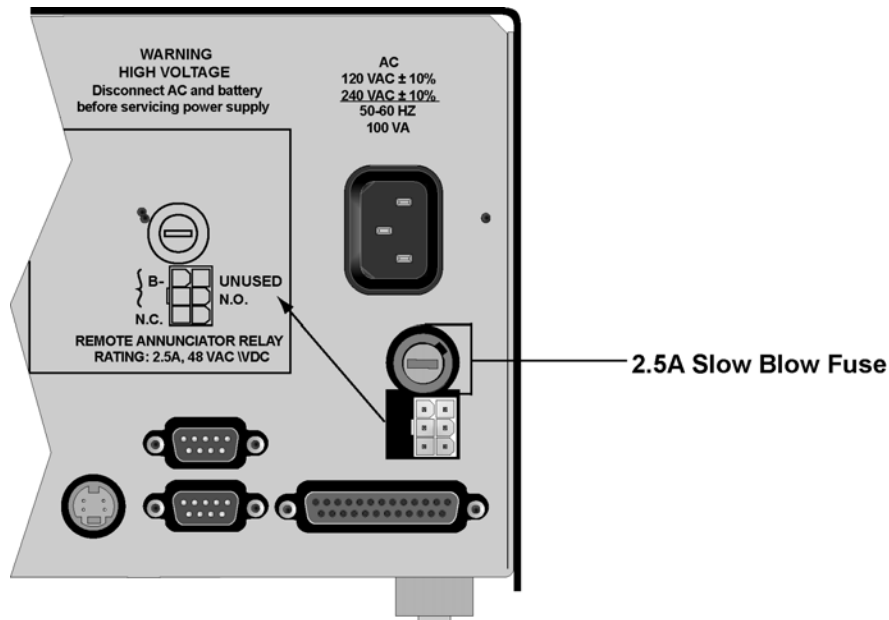

Figure 7-1 Replacing the Power Supply Fuse

3. Using a flathead screw driver, gently turn the fuse holder counterclockwise to remove.
4. Remove the existing fuse from the fuse cap and replace with a 2.5A slow blow fuse.
5. Reinsert the fuse cap in the 9500 and gently turn clockwise until it is seated.

7.4 Safe Mode

Safe mode can be used to reset User #01 access code back to default of 9500 regardless of its present setting.

For Example, if the code for the installer (User #01) is lost and additional programming is required the receiver can be restarted in safe mode to return User #01 to an access code of 9500.

Follow these steps to initiate Safe Mode and default User code #01:

1. Follow the steps in Section 4.6.7 to restart the receiver.

Note: All messages must be acknowledged before a system restart procedure can be performed. If all messages are not acknowledged, cycle the receiver's power to restart the system. If the power is cycled all unacknowledged messages will be lost.

2. When the display shows

```
Model 9500 Receiver
Silent Knight
```

3. Press the  button, then the button.

The display will read

```
Safe Mode Activated
```

4. Press .

5. Enter the default Installer code or 9500.

7.5 Updating the Receiver Software

Silent Knight will continue to test reporting formats with the 9500 receiver. As additional reporting formats become available it may be necessary to update your receiver. This can be done from your own PC, using a null modem cable (see Figure 3-14 and Figure 3-15). Any software upgrades will be sent to you on a 3.5 inch floppy disk and will come with downloading instructions.

Appendix A

Programming Quick Reference Chart

Table A-1: Programming Quick Chart

Program Mode Options	Choices	Choices	Choices	Choices	Comments
General Options	Operation Mode	Manual			See Section 4.5 for description of modes of operation. See also Section 5.4.1.
		Automatic			
		Log Only			
	Language	English			See Section 5.4.2 for details.
		español			
	Time Format	AMPM			Not available at this time.
		24Hr			
	Date Format	M/D/Y			12 hour clock. See Section 5.4.2.2 for details.
		D·M·Y			
		Y-M-D			
Day Light Saving	Yes/No			24 hour clock. See Section 5.4.2.2 for details.	
	Start Month				
Display Options	ITI Options	Jan-Dec			See Section 5.4.2.3 for details.
		1st - 4th and Last			
		Jan-Dec			
		1st - 4th and Last			
Format Config.	FSK 1	Attempts			M = month, D = day, Y = year.
		CPU Time			
		CPU Type			
		Panel Rev			
		Arming Level			
		Code			
		English			
General Options		Yes/No			See Section 5.4.2.4 for details.
		Start Month			
Display Options	ITI Options	Jan-Dec			See Section 5.4.2.5
		1st - 4th and Last			
		Jan-Dec			
		1st - 4th and Last			
Format Config.	FSK 1	Attempts			Affects printer and LCD output only.
		CPU Time			
		CPU Type			
		Panel Rev			
		Arming Level			
		Code			
		English			

Table A-1: Programming Quick Chart

Program Mode Options	Choices	Choices	Choices	Comments
			Code	If "English" is selected, the printer and LCD output will be text. If "Code" is selected then the printer and LCD will display the SIA codes followed by zone or other information. See Section 5.4.2.6 for step-by-step instructions.
	BSEFK		English	This option only affects the SK Expanded automation protocol output. If "English" is selected each event will be sent to the automation as two SIA events; the first with the two digit Group number and the second with the three digit ID number. If "Code" is selected, each event is sent as eleven digits; two digits Message type, one-digit Event Qualifier, three-digit Event Code, two-digit Group Number, and three-digit ID number. See Section 5.4.2.6 for step-by-step instructions.
	SIA		Code English	If "English" is selected then the printer and LCD output for calls of these formats will be text descriptions. If "Code" is selected then the printer and LCD output for calls of these formats will be the Code and Zone numbers. See Section 5.4.2.6 for step-by-step instructions.
General Options (cont.)	Display Options (cont.)	Format Config. (cont.)	Code	If "English" is selected, the printer and LCD output will be text. If "Code" is selected then the printer and LCD will display the SIA codes followed by zone or other information. See Section 5.4.2.6 for step-by-step instructions.
			English	This option only affects the SK Expanded automation protocol output. If "English" is selected each event will be sent to the automation as two SIA events; the first with the two digit Group number and the second with the three digit ID number. If "Code" is selected, each event is sent as eleven digits; two digits Message type, one-digit Event Qualifier, three-digit Event Code, two-digit Group Number, and three-digit ID number. See Section 5.4.2.6 for step-by-step instructions.
	PULSE		0 .. 9 0 .. F	If "0 .. 9" is selected hexadecimal digits B through F are forced to 0 as in the way the 9000 receiver does it, or if "0 .. F" is selected digits are sent as is.
	SK9000		Packed Unpacked	Each data packet to the automation contains a single (unpacked) or multiple (packed) events. See Section 5.4.2.6.
	ACRON		Zero and Space	If set to Space then zero characters are translated as a space, if set to Zero then a zero is sent as a zero. See Section 5.4.2.6.
	HISPEED		SAI and HiSpeed	If set to SIA then an event is translated to SIA format when sent to the automation computer. See Section 5.4.2.6.
	Virtual		Printer	If set to Printer, line card slot numbers are sent to SK9000 automation and printer.
			All	If set to All, virtual line numbers are sent to SK9000 automation and printer.

Table A-1: Programming Quick Chart

Program Mode Options	Choices	Choices	Choices	Comments	
Display Options (cont.)	Hold last event	Yes No		If Yes, LCD will display the last acknowledged event instead of the date/time display in the auto mode. In manual mode the display will show the oldest unacknowledged event. See Section 5.4.2.6.	
	Port Functions	Com1 Com2 Par (Parallel)	Unused/Automation/Printer/ Unused/[Auto Bkp]/[Auto Bkp Prm]/[Print Bkp]/Diag/Printer Unused/[Auto Bkp]/Printer/Diag	Rules for Port Configuration: Functions in Brackets [] appear only if "Automation" is selected for Com1. Functions in { } appear only if "Printer" is selected in Com1 or Par. A function may be selected only once in the 3 ports (only one printer, only one Diag, etc.). All ports may be configured "Unused". See Section 5.4.3.1.	
General Options (cont.)	Baud		38400, 19200, 9600, 7200, 4800, 2400, 1200, 600, 300, 110	See Section 5.4.3.2 for details.	
	D (# Data Bits)		8, 7		
	S (# Stop bits)		1 or 2		
	P (Parity)		Even, Odd, No,		
	Port Monitor		Yes, No		
	F (Flow Control)		Hdwr, Sftwr, None		
	Init Str (Initialization String)			Enter ASCII characters for the Escape command sequence desired. For example: Set the page size or number of lines per page for a serial printer.	
	Com Port2		Same as Com1		
	Par Port		Edit Init String Clear Init String	Enter or edit an Escape command sequence. For example: Set the page size or number of lines per page for a printer.	
	Automation Cfg.	Format		SK EXP, SK9000, SIA CIS, CAPS, FBI I220, ADEM 685, ITIComp, ITI Gen	See Section 5.4.3.5 for details.
		Hex		Y (yes) N (no)	This feature is only available if SK 9000 automation protocol is selected.
		Heartbeat		Y (yes) N (no)	
		Time (of heartbeat)		10-600 seconds	
Ack timeout			1 to 120 seconds		

Table A-1: Programming Quick Chart

Program Mode Options	Choices	Choices	Choices	Comments	
General Options (cont.)	Communication (cont.)	Annunciator Configuration	Printer	Yes or No	Yes = will annunciate if an event, trouble or fault condition occurs. No = no annunciation if an event, trouble or fault condition occurs. Default for all options: Yes. See Section 5.4.3.6. * Listen In option must be set to No for UL installations.
			Bkp Printer	Yes or No	
			Auto Comp	Yes or No	
			Bkp Auto Comp	Yes or No	
			Battery	Yes or No	
			Device	Yes or No	
			Line Fault	Yes or No	
			AC Power	Yes or No	
			Buffer Full	Yes or No	
			Listen In	Yes or No	
Call Pending	Yes or No				
Aux Relay Cfg	Options the same as Annunciator Configuration. See Section 5.4.3.7. * Listen In option must be set to No for UL installations.				
System Options	Battery Backup Cfg	No Battery Bkpb	No Battery Bkpb	No charging current applied to battery circuit. Receiver will not test battery output or give trouble annunciations. Default. See Section 5.4.4.1.	
			DC Bkpb	No charging current applied to battery circuit. Typically used for systems that use a UPS (uninterrupted power supply) for backup battery power. See Section 5.4.4.1.	
			Battery Bkpb	Charging current applied to battery circuit. See Section 5.4.4.1.	
			01-99	Default: 01. See Section 5.4.4.2.	
			Strip Bad	An indicator is sent to the automation computer that indicates a bad data block was received. Default. See Section 5.4.4.3	
			Send Bad	Same as Strip Data except the bad data block is sent with the indicator. See Section 5.4.4.3	
			Off	Off= Deenergized. Default.	
			Energized	On = Energized See Section 5.4.4.4.	
			60 Hz	Receiver clock runs on 60Hz AC power input. See Section 5.4.4.5	
			50 Hz	Receiver clock runs on 50Hz AC power input. See Section 5.4.4.5.	
Int	Receiver clock runs on internal crystal. Use in areas where AC line frequency is not dependable. See Section 5.4.4.5.				

Table A-1: Programming Quick Chart

Program Mode Options	Choices	Choices	Choices	Choices	Comments
General Options (cont.)	Message Queue Options	% Warning Lvl	On: 10 to 99%		Percentage full message queue must reach before a trouble indication occurs. Default: 75%. See Section 5.4.5.1.
		Event Release Sec.	Off: 01 to 90%		Percentage message queue must drop to clear a trouble indication. Default: 50%. See Section 5.4.5.2.
Line Device Menu	Add Device	Enter Device #	1, 20 to 120 sec		Time from call beginning until events released to system. Default: 60 sec. See Section 5.4.5.3.
			Use Defaults		See Section 5.5.1 for details.
			Copy Existing		
			Sequence Number	1 to 6	The order in which the line card will output different handshakes. Number 1 is sent first and number 6 is sent last. See page 5-37.
			Format Group	2225 Hz 2300 Hz 1400 Hz 1400_2300Hz Westec Modem Ite Modem II Reserved 1400_2300-2 Not Used	Handshake type. See page 5-37
			Handshake Sequence		
			Edit Line		
			HS Duration*	9810: 0 to 250 msec	Length of time the receiver will send a handshake tone. See page 5-38.
			Max Wait†	9815: 0 to 9999 msec	Length of time the receiver will wait for data from the reporting panel before sending the next handshake tone. See page 5-39
			Ack Duration*	* Each numeric option is 10 times the displayed value. Example—064 X 10 = 640 msec. † Each numeric option is 50 times the displayed value. Example—004 X 50 = 200 msec.	Length of time the receiver will send an acknowledgement tone to the reporting panel. See page 5-39
		Pulse Format	4/1	If a pulse comes in a 5-digit format the data is treated as the selected format.	
		5-digit Format	3/2		
			3/1CS	3 by 1 w/Check sum	

Table A-1: Programming Quick Chart

Program Mode Options	Choices	Choices	Choices	Comments
		6-digit Format	4/2 3/2CS 4/1CS	If a pulse comes in a 6-digit format then the data will then be treated as the selected format. 3 by 2 w/Check sum 4 by 1 w/Check sum
	Pulse Format (cont.)	Timeout (Inter-digit Tm [ms])	300 ms to 2 Sec.	This feature selects the time period between data blocks. If 0000 is selected then the receiver will use an automatic algorithm.
		Ack/Even (Ack on Even Round)	Yes No	Select this option if the 1400 or 2300 Hz format requires a Ack tone on even rounds.
		Part (Partially Extended)	Yes No	Select this option if you have multiple extended data blocks for 3/1 or 4/1 formats.
		Direct	Y (Yes) No (No)	Y = dedicated or direct connect phone line. N = used for standard phone lines. See page 5-41 for more information.
Line Device Menu (cont.)	Edit Line (cont.)	Number of Rings	000-255	Number of rings the line card needs to receive before it will answer a call. It is recommended that number of rings is not set higher than 005. If Caller ID is turned on, set to 002 (see page 5-52 for more information on the Caller ID option). See page 5-42 for more information on Number of Rings.
		On time	1-255 in 50ms periods	9810 line card only. See page 5-42 for more information.
		Off time	1-255 in 50ms periods	9810 line card only. See page 5-43 for more information.
		dB Level	Lo (Low) Hi (High) Md (Medium)	9810 line card only. Select the db level of the handshake and acknowledge tones.
		Country Code	See page 5-44	9815 line card only. Some Country Code selections support multiple countries. See page 5-44 for detailed list.
		Threshold	1-15 in 2.0 VDC steps	See page 5-45.
		Fault Detect (Sample)	0-255 sec - 9810 0-90 sec - 9815	See page 5-45.

Table A-1: Programming Quick Chart

Program Mode Options	Choices	Choices	Choices	Comments	
Program Mode Options	Listen In	Listen Mode	Not Used Common PBX	See page 5-46 for more information. Must not be used in UL installations.	
			Account List	Add up to 20 accounts. See page 5-49. See page 5-49. See page 5-49.	
		PBX String edit Timeout	0-255	Only available if PBX is selected in Listen Mode. See page 5-47. See page 5-48.	
	Trap List	Account List	Add Account Edit Account Clear Account	See page 5-48.	
		Add Account Edit Account Clear Account	Enter Account # Choose Account Choose Account	See page 5-50 through page 5-51.	
		Echo Suppress	Y (Yes)	Outputs a 2 second 2025Hz tone to disable echo suppression equipment that may interfere with modem formats. See page 5-52	
	Line Device Menu (cont.) Edit Line (cont.)	Misc. Line Options	Caller ID	N (No) Yes No	The Caller ID information will only be sent on incoming call messages that contain no data. If the call message contains any data (valid or invalid) no Caller Id information will be output. See page 5-52.
			Billing Delay	Y (Yes) N (No)	Initiates a 2 second delay at the start of each call before the handshake delay. See page 5-52 for more information.
			Hunt Group	00-99	Allows multiple line cards to report under the same group number to the automation software.
			Ring Options	Min Ring Max Ring Ring Off Min Ring Off Ring Off Error Min # Rings Period	9815 line card only. See page 5-53.
		Call Hang Up		Max number of seconds the line card will stay off hook for a call. Helps prevent a run away panel from monopolizing the phone line. See page 5-54.	

Table A-1: Programming Quick Chart

Program Mode Options	Choices	Choices	Choices	Comments
Line Device Menu (cont.)	Edit Line (cont.)	BFSK AutoOut	H/S	Used to setup communication with a automation system using ADEMCO 685 or CAPS. See Section 5.5.2.9.
		3/1 Restore Out	4/2	
		4/2 Auto Out	3/1	
		FBI Printer Out	H/S	
		Pulse Extended	H/S	
		Extend Out	Nor	
			S/Fast	
			LAR300	
			Ext	
			No Ext	
			H/S	
			4/2	
Line Device Menu (cont.)	Edit Line (cont.)	ITL SCode Menu	Default SCode	Used in communication locking on ITI panels. See Section 5.4.2.5. and Section 5.5.2.10.
		Date/Time Flag	Add Acct/SCode	
		ITL 300 Baud	Edit Acct/SCode	
		Audio Mode	Clear Acct/SCode	
		Transmit Gain	Add SCode Table	
		Receive Gain	Clear SCode Table	
		CID Monitor	Requested	
		CID Gain	Always	
		On Hook Gain	Yes	
		Ringer Imped	No	
			Instant	
			One Ring	
	Dial Back			
	-3 to 14 dB			
	0 to 12 dB			
	Norm, Pream, DTMF, or Marks			
	-6 to 7 dB			
	2 to 7 dB			
	HI or SY			

Table A-1: Programming Quick Chart

Program Mode Options	Choices	Choices	Choices	Choices	Comments
Line Device Menu (cont.)	Use Defaults	Choose Line card(s) #			Choose Line card(s) # that you wish to be programmed to factory defaults.
	Copy Device(s)	Copy Existing	Choose Line card # of Source Line Card	Choose the target line card(s) #.	Copy the programming of one line card (source) and paste it into one or several (target) line cards.
	Clear Device	Line Card #			See Section 5.5.4 for details.
	View Device	Line Card #			See Section 5.5.5 for details.
User List	Rollins	Line Card #(s)			See Section 5.5.6 for details.
	Add User	User Name	Up to 16 characters.		
		User Code	4-9 digits		
		User Profile	Installer/Operator		
	Edit User	List of users	User name, code and profile		
		Clear User	List of users		

Silent Knight Fire Product Warranty and Return Policy

Limited Warranty

Silent Knight warrants that the products of its manufacture shall be free from defects in materials or workmanship for five years from the manufacturing date code on the printed circuit board, if such goods have been properly installed, are subject to normal proper use, and have not been modified in any manner whatsoever. Upon return of the defective product, Silent Knight will at its sole discretion, either repair or replace, at no cost, such goods as may be of defective material or workmanship. Customers outside the United States are to return products to their distributor for repair.

Silent Knight SHALL NOT UNDER ANY CIRCUMSTANCES BE LIABLE FOR ANY INCIDENTAL OR CONSEQUENTIAL DAMAGES ARISING FROM LOSS OF PROPERTY OR OTHER DAMAGE OR LOSSES OWING TO THE FAILURE OF Silent Knight PRODUCTS BEYOND THE COST OF REPAIR OR REPLACEMENT OF ANY DEFECTIVE PRODUCTS.

Silent Knight MAKES NO WARRANTY OF FITNESS OR MERCHANTABILITY AND NO OTHER WARRANTY, ORAL OR WRITTEN, EXPRESS OR IMPLIED, BEYOND THE 18 MONTH WARRANTY EXPRESSLY SPECIFIED HEREIN.

IMPORTANT: Silent Knight products should be tested weekly to ensure complete and proper operation and proper input and output connections.

Repair and RA Procedure

- All products that are returned to Silent Knight for credit or repair require a RA (Return Authorization) number. Call Silent Knight Customer Service at 800-446-6444 or 763-493-6435 between 8:00 A.M. and 4:45 P.M. CST, Monday through Friday to obtain a return authorization number. Silent Knight Technical Support is available at 800-328-0103 between 8:00 A.M. and 6:00 P.M. CST, Monday through Friday.
- RA number must be prominently displayed on the outside of the shipping box. See return address example under Advanced Replacement Policy.
- Include a packing slip that has the RA number, a content list, and a detailed description of the problem should be included with each return.
- All products returned to Silent Knight must be sent freight pre-paid. After product is processed, Silent Knight will pay for shipping product back to customer via UPS ground.
- Do not return batteries. Silent Knight has the authority to determine if a product is repairable. Products that are deemed un-repairable will be returned to the customer.

- Product that is returned that has a board date code more than five years from date of manufacture will be repaired and the customer will be assessed the standard Silent Knight repair charge for that model.

- Repairs and returns should be sent to:

Silent Knight

Attn: Repair Department

7550 Meridian Circle Suite 100

Maple Grove, MN 55369-4927

RA Number: _____

Index

Numerics

230 VAC	3-12
25-Pin Null Modem Cable	3-16
9-Pin Null Modem Cable	3-16

A

Accessories	1-2
Acknowledge Time	5-19
Acknowledgment Tone Duration Time	5-39
Automation Communication Format	5-17
Auxiliary Relay	3-1, 5-22, 5-25

B

Backup Battery	5-24
----------------------	------

C

Caller ID	5-34, 5-42, 5-52, A-7
Com Port 1	3-16, 5-15
Com Port 2	5-15
communication option	5-12
computer port baud rate	3-16
Configure Printer	4-21

D

Date Format Display	5-9
Day Light Saving	5-9
Dedicated Line	5-41
default settings	1-5
Default User Codes	4-6
delete a user	5-68
Direct Line	5-41
Display options	5-6

E

earth ground	3-13
Enter Program Mode	5-1

F

FCC	2-1
FCC Registration Number	2-1
Features	1-1
firmware information	4-12
Formats	1-3
Fuse	3-1

G	
General Options	5-3
Grounding	3-13
H	
Handshake Duration	5-38
Handshake Sequence	5-37
Handshake Wait	5-39
Heartbeat	5-18, 5-19
Hold Last Event	5-11
I	
Initialization string (Init string)	5-16
ITI Computer Interface format	5-20
ITI Formats	5-21
ITI Generic	5-20
ITI Panels	5-21
ITI Security Code	5-57
L	
Language Display	5-8
LCD	4-3
LCD Contrast	4-4
LED	4-3
Line card	5-31
Line Options	5-41
Line Voltage	3-1
Listen-in	4-29
log off	4-7
log on	4-6
Log Record	5-21
M	
Main Menu	4-9
Main Menu Option Items by Profile	4-5
Maneuver Around in Program Mode	5-2
Maneuver Through Main Menu	4-10
Manual (Common) Listen-In	4-29
model number	4-12
N	
Normal mode	4-8
O	
On-board Annunciator	5-22
Operation mode	5-4, 5-5

P

PBX string	4-30
Phone Line Sample Rate	5-45
PIN	1-5, 4-6, 5-65, 5-66, 5-67
Port function	5-14
Power Up	4-5
Print a Test Page	4-20
Print Call History	4-17
print menu	4-15
Print Report	4-17
Print System Configuration	4-19
Print System History	4-18
printer cable	3-8
Program Menu	4-22
Programming	5-1
Programming Choices	5-3
Programming Fields	5-2

R

Receiver ID	4-12, 5-24
Ring Off Time	5-43
Ring On Time	5-42
Ring Threshold Voltage	5-45
Rings	5-42

S

Set Time & Date	4-13
software date code	4-12
software revision	4-12
Supervisory Character	5-21
System History	4-11
System Info	4-12
System Options	5-23

T

Testing	4-30
Threshold	5-45
Time Format Display	5-8
Touchpad Buttons	4-2

U

User List	5-65
-----------------	------



**SILENT
KNIGHT**

by Honeywell

7550 Meridian Circle
Maple Grove, MN 55369-4927
763-493-6455
1-800-328-0103
Fax: 763-493-6475

© 2006 Silent Knight