

BUSH HOG®

ESTATE ZERO TURN MOWER GRASS CATCHER Model GC-310



Operator's Manual

ASSEMBLY ● OPERATION ● MAINTENANCE

CONGRATULATIONS!

You have invested in the best implement of its type on the market today.

The care you give your Bush Hog implement will greatly determine your satisfaction with its performance and its service life. We urge a careful study of this manual to provide you with a thorough understanding of your new implement before operating, as well as suggestions for operation and maintenance.

If your manual should become lost or destroyed, Bush Hog will be glad to provide you with a new copy. Order from Bush Hog, P. O. Box 1039, Selma, Alabama 36702-1039. Most of our manuals can also be downloaded from our website at www.bushhog.com.

As an authorized Bush Hog dealer, we stock genuine Bush Hog parts which are manufactured with the same precision and skill as our original equipment. Our trained service personnel are well informed on methods required to service Bush Hog equipment, and are ready and able to help you.

Should you require additional information or assistance, please contact us.

YOUR AUTHORIZED
BUSH HOG DEALER

BECAUSE BUSH HOG MAINTAINS AN ONGOING PROGRAM OF PRODUCT IMPROVEMENT, WE RESERVE THE RIGHT TO MAKE IMPROVEMENTS IN DESIGN OR CHANGES IN SPECIFICATIONS WITHOUT INCURRING ANY OBLIGATION TO INSTALL THEM ON UNITS PREVIOUSLY SOLD.

BECAUSE OF THE POSSIBILITY THAT SOME PHOTOGRAPHS IN THIS MANUAL WERE TAKEN OF PROTOTYPE MODELS, PRODUCTION MODELS MAY VARY IN SOME DETAIL. IN ADDITION, SOME PHOTOGRAPHS MAY SHOW SHIELDS REMOVED FOR PURPOSES OF CLARITY. **NEVER OPERATE** THIS IMPLEMENT WITHOUT ALL SHIELDS IN PLACE.

ESTATE ZERO TURN MOWER GRASS CATCHER TABLE OF CONTENTS

SECTION	PAGE	SECTION	PAGE
Warranty	2	2-9 Attachment of The Upper Hose	8
Federal Laws and Regulations	3	2-10 Attachment Of The Upper Hose To	8
Safety Alert Symbols	4	The Lower Cone	
I INTRODUCTION AND DESCRIPTION	5	2-11 Attachment Of The Lower Hose To	8
1-1 Introduction	5	The Boot	
1-2 Description	5	2-12 Front Weight Assembly	8
II PREPARATION FOR USE	5	2-13 Installation/Removal Of Collection Bags	8
2-1 Modification Of ZT	5	III OPERATING INSTRUCTIONS	10
2-2 Attaching Frame Mount Brackets	6	3-1 General Safety	10
2-3 Belt Installation	6	3-2 Operation & Tips On Mowing	10
2-4 Cam Assembly Adjustment	7	3-3 Disengagement Of The Blower	10
2-5 Attachemnt Of Upper Frame	7	IV MAINTENANCE	10
Assembly To The Lower Frame		4-1 Maintenance Checklist	10
2-6 Attachment Of Top Assembly To The	7	4-2 Lubrication	11
Upper Frame Assembly		Safety Decals	12
2-7 Attachment Of The Boot To	7	Torque Specifications	13
The Mower Deck			
2-8 Adjustment Of The Lengths Of Hoses	8		

RETAIL CUSTOMER'S RESPONSIBILITY UNDER THE BUSH HOG WARRANTY

It is the Retail Customer and/or Operator's responsibility to read the Operator's Manual, to operate, lubricate, maintain and store the product in accordance with all instructions and safety procedures. Failure of the operator to read the Operator's Manual is a misuse of this equipment.

It is the Retail Customer and/or Operator's responsibility to inspect the product and to have any part(s) repaired or replaced when continued operation would cause damage or excessive wear to other parts or cause a safety hazard.

It is the Retail Customer's responsibility to deliver the product to the authorized Bush Hog Dealer, from whom he purchased it, for service or replacement of defective parts which are covered by warranty. Repairs to be submitted for warranty consideration must be made within forty-five (45) days of failure.

It is the Retail Customer's responsibility for any cost incurred by the Dealer for traveling to or hauling of the product for the purpose of performing a warranty obligation or inspection.

BUSH HOG® LIMITED WARRANTY



Bush Hog warrants to the original purchaser of any new Bush Hog equipment, purchased from an authorized Bush Hog dealer, that the equipment be free from defects in material and workmanship for a period of one (1) year for non-commercial, state, and municipalities' use and ninety (90) days for commercial use from date of retail sale. The obligation of Bush Hog to the purchaser under this warranty is limited to the repair or replacement of defective parts.

Replacement or repair parts installed in the equipment covered by this limited warranty are warranted for ninety (90) days from the date of purchase of such part or to the expiration of the applicable new equipment warranty period, whichever occurs later. Warranted parts shall be provided at no cost to the user at an authorized Bush Hog dealer during regular working hours. Bush Hog reserves the right to inspect any equipment or parts which are claimed to have been defective in material or workmanship.

DISCLAIMER OF IMPLIED WARRANTIES & CONSEQUENTIAL DAMAGES

Bush Hog's obligation under this limited warranty, to the extent allowed by law, is in lieu of all warranties, implied or expressed, **INCLUDING IMPLIED WARRANTIES OF MERCHANTABILITY AND FITNESS FOR A PARTICULAR PURPOSE** and any liability for incidental and consequential damages with respect to the sale or use of the items warranted. Such incidental and consequential damages shall include but not be limited to: transportation charges other than normal freight charges; cost of installation other than cost approved by Bush Hog; duty; taxes; charges for normal service or adjustment; loss of crops or any other loss of income; rental of substitute equipment, expenses due to loss, damage, detention or delay in the delivery of equipment or parts resulting from acts beyond the control of Bush Hog.

THIS LIMITED WARRANTY SHALL NOT APPLY:

1. To vendor items which carry their own warranties, such as engines, tires, and tubes.
2. If the unit has been subjected to misapplication, abuse, misuse, negligence, fire or other accident.
3. If parts not made or supplied by Bush Hog have been used in connection with the unit, if, in the sole judgement of Bush Hog such use affects its performance, stability or reliability.
4. If the unit has been altered or repaired outside of an authorized Bush Hog dealership in a manner which, in the sole judgement of Bush Hog, affects its performance, stability or reliability.
5. To normal maintenance service and normal replacement items such as gearbox lubricant, hydraulic fluid, worn blades, or to normal deterioration of such things as belts and exterior finish due to use or exposure.
6. To expendable or wear items such as teeth, chains, sprockets, belts, springs and any other items that in the company's sole judgement is a wear item.

NO EMPLOYEE OR REPRESENTATIVE OF BUSH HOG IS AUTHORIZED TO CHANGE THIS LIMITED WARRANTY IN ANY WAY OR GRANT ANY OTHER WARRANTY UNLESS SUCH CHANGE IS MADE IN WRITING AND SIGNED BY BUSH HOG'S SERVICE MANAGER, POST OFFICE BOX 1039, SELMA, ALABAMA 36702-1039.



Record the model number, serial number and date purchased. This information will be helpful to your dealer if parts or service are required.

MODEL NUMBER _____

SERIAL NUMBER _____

MAKE CERTAIN THE WARRANTY REGISTRATION CARD HAS BEEN FILED WITH BUSH HOG/
SELMA, ALABAMA

DATE OF RETAIL SALE _____

IMPORTANT FEDERAL LAWS AND REGULATIONS* CONCERNING EMPLOYERS, EMPLOYEES AND OPERATIONS.

*(This section is intended to explain in broad terms the concept and effect of the following federal laws and regulations. It is not intended as a legal interpretation of the laws and should not be considered as such).

U.S. Public Law 91-596 (The Williams-Steiger Occupational and Health Act of 1970) OSHA

This Act Seeks:

“...to assure so far as possible every working man and woman in the nation safe and healthful working conditions and to preserve our human resources...”

DUTIES

Sec. 5 (a) Each employer—

- (1) shall furnish to each of his employees employment and a place of employment which are free from recognized hazards that are causing or are likely to cause death or serious physical harm to his employees;
- (2) shall comply with occupational safety and health standards promulgated under this Act.
 - (b) Each employee shall comply with occupational safety and health standards and all rules, regulations and orders issued pursuant to this Act which are applicable to his own actions and conduct.

OSHA Regulations

Current OSHA regulations state in part: “At the time of initial assignment and at least annually thereafter, the employer shall instruct every employee in the safe operation and servicing of all equipment with which the employee is, or will be involved.” These will include (but are not limited to) instructions to:

Keep all guards in place when the machine is in operation;

Permit no riders on equipment;

Stop engine, disconnect the power source, and wait for all machine movement to stop before servicing, adjusting, cleaning or unclogging the equipment, except where the machine must be running to be properly serviced or maintained, in which case the employer shall instruct employees as to all steps and procedures which are necessary to safely service or maintain the equipment.

Make sure everyone is clear of machinery before starting the engine, engaging power, or operating the machine.

EMPLOYEE TRACTOR OPERATING INSTRUCTIONS:

1. Securely fasten your seat belt if the tractor has a ROPS.
2. Where possible, avoid operating the tractor near ditches, embankments, and holes.
3. Reduce speed when turning, crossing slopes, and on rough, slick, or muddy surfaces.
4. Stay off slopes too steep for safe operation.
5. Watch where you are going, especially at row ends, on roads, and around trees.
6. Do not permit others to ride.
7. Operate the tractor smoothly - no jerky turns, starts, or stops.
8. Hitch only to the drawbar and hitch points recommended by tractor manufacturers.
9. When tractor is stopped, set brakes securely and use park lock if available.

Child Labor Under 16 Years Old

Some regulations specify that no one under the age of 16 may operate power machinery. It is your responsibility to know what these regulations are in your own area or situation. (Refer to U.S. Dept. of Labor, Employment Standard Administration, Wage & Home Division, Child Labor Bulletin #102.)

Safety Alert Symbol



This Safety Alert Symbol means: “**ATTENTION! BECOME ALERT! YOUR SAFETY IS INVOLVED!**”

This symbol is used to call attention to safety precautions that should be followed by the operator to avoid accidents. When you see this symbol, carefully read the message that follows and heed its advice. Failure to comply with safety precautions could result in death or serious bodily injury.

Safety Signs *Signal Words*

The signal words **DANGER, WARNING, AND CAUTION** are used on the equipment safety signs. These words are intended to alert the viewer to the existence and the degree of hazard seriousness.

 **DANGER**

White letters on **RED**

This signal word indicates a potentially hazardous situation which, if not avoided, will result in death or serious injury.

 **WARNING**

Black letters on **ORANGE**

This signal word indicates a potentially hazardous situation which, if not avoided, could result in death or serious injury

It may also be used to alert against unsafe practices.

 **CAUTION**

Black letters on **YELLOW**

This signal word indicates a potentially hazardous situation exist which, if not avoided, may result in minor or moderate injury.

It may also be used to alert against unsafe practices.

SECTION I INTRODUCTION AND DESCRIPTION

Figure 1



1-1 Introduction

We are pleased to have you as a return Bush Hog customer. Your GC-310 has been designed to give you a low maintenance, simple, and effective way to collect the grass clippings from your Bush Hog Estate ZT mower. This manual is provided to give you the necessary instructions to properly mount and operate the GC-310 on your ZT mower. Please read this manual thoroughly. Understand what each control is for and how to use it. Observe all safety decal precautions on the machine and noted throughout the manual.

Note: all references made to right, left, front, rear, top or bottom are as viewed from the normal operator's position on the ZT mower.

Note: All work must be performed with the engine off and the parking brake locked.

1-2 Description

The GC-310 Grass Catcher, Figure 1, is designed for turf maintenance where there is a need to collect the grass clippings as the ZT mower cuts the turf. It is also good for picking up leaves and twigs in pre-season and post-season clean-up.

The blower, mounted on the right side of the unit, uses a belt and gearbox system from the engine PTO shaft. Drive train protection comes through belt slippage. The blower draws grass clippings from the discharge area of the cutter deck up to the collection bags mounted over the rear portion of the ZT frame. The operator can engage the blower with a push of the over-center linkage on the right side of the unit. Once the bags are full of clippings, the top of the unit can be pivoted up and each of the three bags can be removed individually for emptying.

Figure 2
Complete Machine
In Shipping Crate



Crate and Boxes
Opened For Parts
Removal



SECTION II PREPARATION FOR USE

2-1 ZT Modification Of Zero Turn

Carefully remove wrapping from around shipping crate and open boxes. Remove and sort all parts for easy identification.

NOTE: Before each step of assembly it will help to study the exploded drawings on pages 7, 8, and 9.

From the underside of the ZT engine remove the bolt and bushing from the electric clutch assembly. Replace these parts with the pulley and 7/16"-20 x 3-1/4" bolt that will power the grass catcher blower. Note that the center of the hub that is extended should be upward toward the engine. (Figure 3) Torque the bolt to 55 ft./lbs.

Figure 3 Electric Clutch Assy. Grass Catcher Pulley

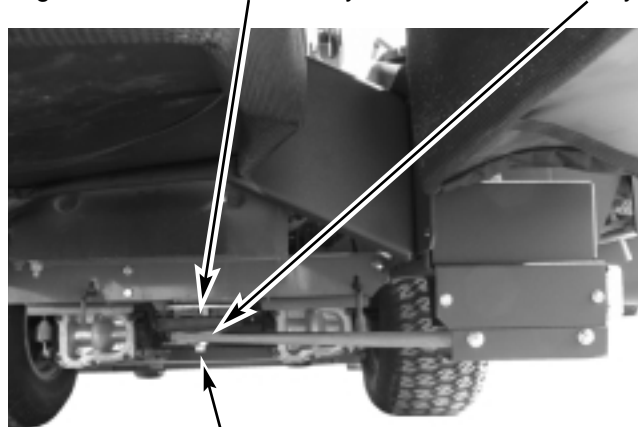

7/16"-20 x 3-1/4" Bolt

2-2 Attaching Frame Mount Brackets

To mount the frame mount brackets which support the bagger unit, you must first remove the existing rear bumper. Mount the brackets to the ZT frame as shown in Figure 4 below using 3/8"-16 x 1" bolts and 3/8" Nyloc nuts. **NOTE: The front two bolt holes on each side in the ZT frame must be enlarged by drilling with a 3/8" drill bit before using the new bolts.**

Figure 4 3/8" Bolts Left Frame Mount Brackets

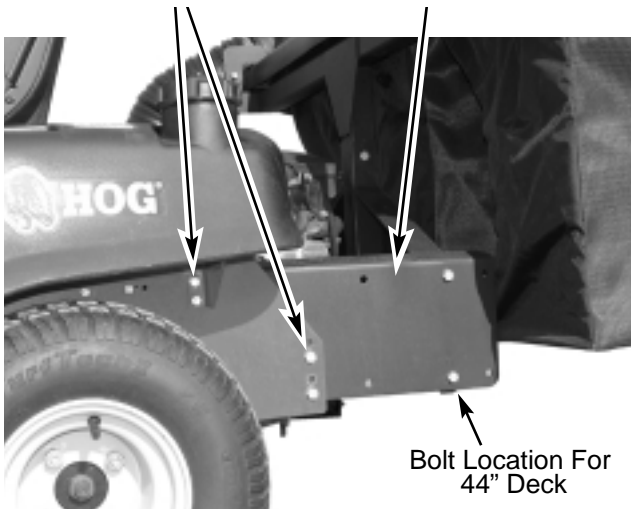

Assemble right frame bracket to opposite side of the ZT frame as shown in Figure 5.

Figure 5 Right Frame Mount Bracket

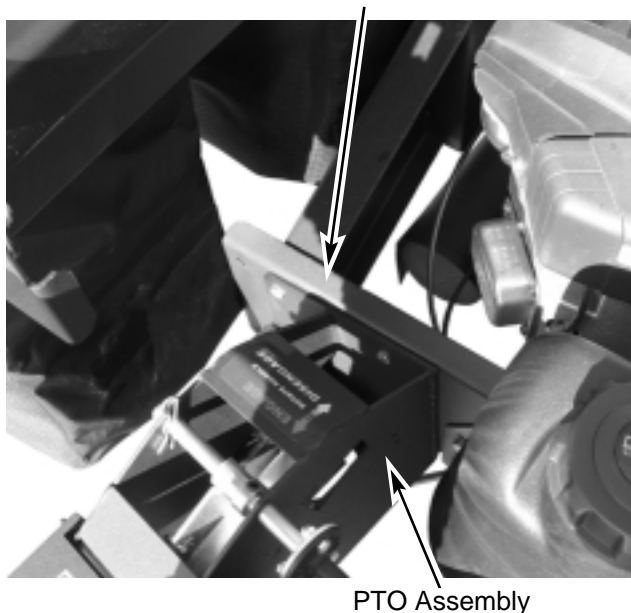

Fasten the PTO assembly to the mount bracket as shown using 5/16 x 1" bolts and nylock nuts. **IMPORTANT: Note that the lower frame assembly must be mounted at the same time utilizing the rear bolts. Also note that the lower frame must be located dependent on the size of the**

deck on your particular ZT. Models with a 44" deck use the front mounting holes and models with a 52" deck use the rear holes.

2-3 Belt Installation

The gear box shield must first be removed to allow access to the bolts that secure the gear box.

Loosen the two bolts that secure the gear box assembly to the PTO mount plate. (Figure 6) Loosen the adjustment bolt until the gear box assembly is at its far left adjustment (the gear box is moved towards the mower's engine pulley). Install the Kevlar cord belt from the engine pulley to the lower gear box pulley. To tension the drive belt, turn the adjustment bolt clockwise until there is 1" of deflection, with 10-11 lbs. of pressure between the engine pulley and the gear box pulley. Once the correct tension on the belt is achieved, tighten the (2) bolts that secure the gear box assembly and re-attach the shield. (Figures 6 and 7)

Figure 6 Gear Box Attachment Bolts Are Under The Shield

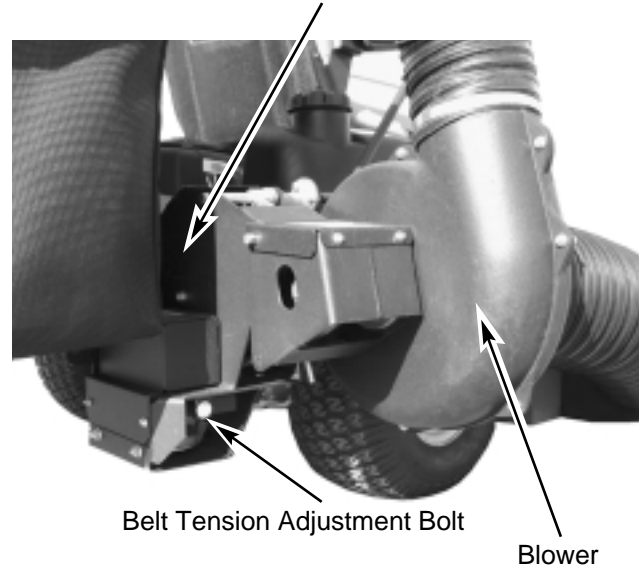
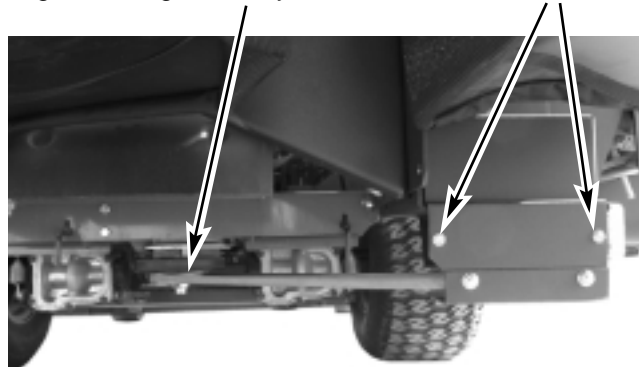

Figure 7 Engine Pulley Gear Box Shield Bolts



2-4 Cam Assembly Adjustment

The cam assembly, which controls the blower belt tension, comes from the factory pre-adjusted. If the belt is too tight, or becomes too loose, remove the hair pin clip from the belt tension rod and pull the "L" end of the rod out of its hole in the cam assembly. The tension rod may then be screwed out to tighten the belt or screwed in to loosen the belt. Replace the "L" end into the top hole in the cam and replace the hair pin clip. Adjust the cam stop bolt to allow the cam to rotate slightly over center when the blower is disengaged. (Figure 8)

Figure 8 Belt Tension Rod Cam Stop Bolt Is Below The Cam Assembly



2-5 Attachment Of Upper Frame Assembly To The Lower Frame

NOTE: During this step it is suggested that two people install the Top Frame to the Lower Frame
Using two people to raise the top frame, lift the top frame above the lower frame making sure the bag frames are located away from the engine as shown in Figure 9. Slide the top frame vertical tube into the lower frame vertical tube aligning the holes. Insert the 1/2" X 2-1/4" clevis pin through the holes and fasten with a hair pin clip.

Figure 9 Top Frame Clevis Pin Lower Frame

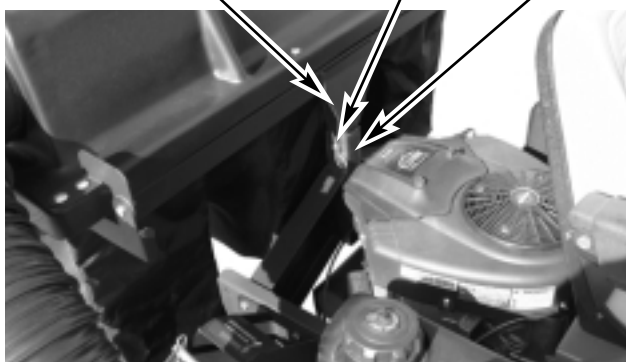

2-6 Attachment Of Top Assembly To The Upper Frame Assembly

Align the pivot brackets of the top assembly to the pivot points on either side of the upper frame assembly. Place a fender washer between each pivot point and fasten each side by using a 5/16" - 18 x 3/4" bolt and nyloc nut. When fastening leave the nut slightly loose so that the top can pivot freely. (Figure 10)

Figure 10 Top Assembly Locates Here

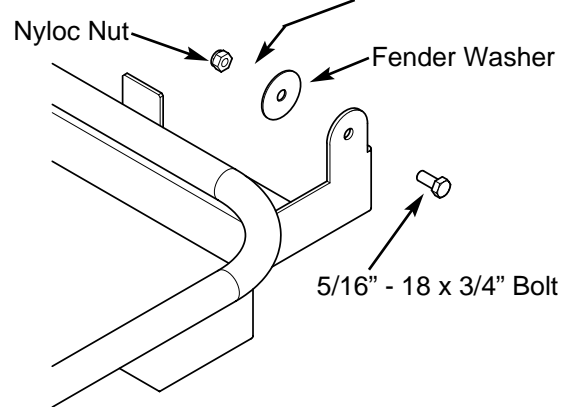

2-7 Attachment Of The Boot To The Mower Deck

Remove the mower's discharge chute from the cutter deck. The boot rod will replace the cap screws and create a mounting surface for the deck boot. Slide the boot rod through the lugs on the cutter deck and fasten into place with a hair pin clip as shown in Figure 11.

Attach the boot plate to the boot using 3/8 x 1" carriage bolts inserted from the inside of the boot. This will prevent grass from building up on the bolts. Use 3/8" serrated, flanged lock nuts on the bolts, but do not tighten at this time. With the rod in place, slide the boot plate tabs under the rod. Allow the boot to rotate down and rest against the cutter deck opening. Adjust the boot location to cover the deck opening and tighten the lock nuts. (Figure 11)

Figure 11 Boot Hair Pin Clip Rod

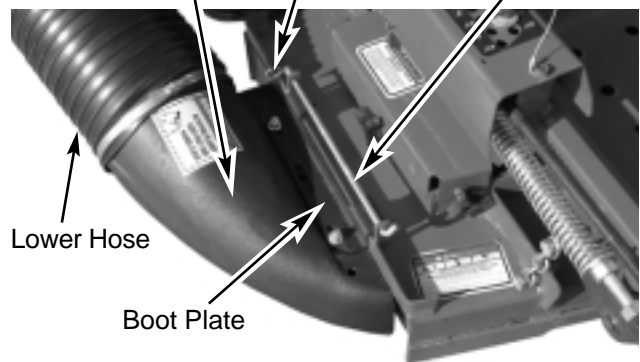

2-8 Adjustment Of The Lengths Of Hoses

The hoses in steps 2-9 and 2-10 must be cut to fit your machine. Follow the steps and do not cut the hoses until you have tried them on your particular machine. Remember that the hoses must be long enough to allow for enough clamping surface between the inlet, blower assembly and the deck boot.

2-9 Attachment Of The Upper Hose

Fasten the inlet to the plastic top by sliding the inlet from the inside of the top to the outside and snap into place. Slide a 5" - 6" upper hose clamp onto both ends of the 6" upper hose, then slide one end of the hose onto the inlet. Make sure there is about a 2" overlap between the hose end and the container inlet. Proceed to slide the opposite end of the hose onto the outlet of the blower assembly as shown in Figure 12. Make sure both ends of the hose are clearly attached to the inlet and the blower assembly inlet. Tighten the hose clamps.

Figure 12 Inlet Hose Clamp 6" Upper Hose

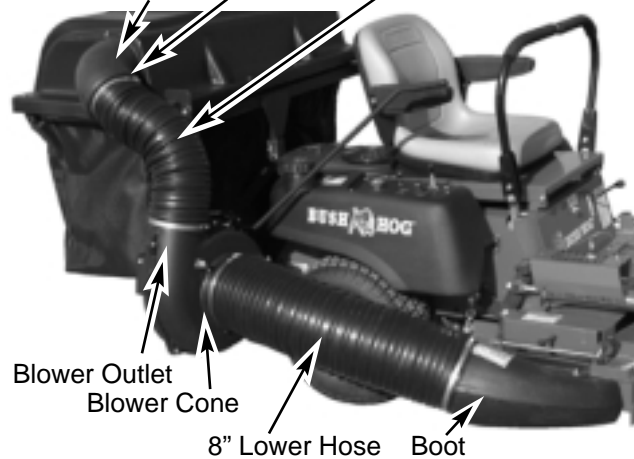

2-10 Attachment Of The Lower Hose To The Blower Cone

Fasten the blower cone to the blower housing by using two 5/16" - 18 x 2-1/2" bolts and jam nuts. Slide a 7"-8" hose clamp over each end of the lower hose, then proceed to slide the lower hose onto the blower cone. Tighten the hose clamps. (Figure 12)

2-11 Attachment Of The Lower Hose To The Boot

Take the unattached end of the lower hose and slide it over the circular end of the boot. Use the lower hose clamp to secure the hose to the boot. (Figure 12) **Tip: Before securing the clamp, rotate the hose counter-clockwise (away from yourself) approximately 1" to aid in retaining boot to mower deck.**

2-12 Front Weight Assembly

Attach each front weight bracket to the front cross member of the ZT frame as shown in Figure 13. Note the positions of the left and right brackets. Fasten with two 3/8 x 3" bolts and flanged locknuts on each side. When installing the 100 lb. weight you should have another person help position the weight onto a floor jack. Using a floor jack will make installing the weight much easier. Lift the weight up to the weight brackets. Fasten the weight to the weight brackets by using a 1/2" 13 x 4-1/2" U-bolt and two flanged locknuts per bracket. Once the weight is secure, tighten all nuts. Be sure weight is centered in reference to the U-bolts. (Figure 13)

Figure 13

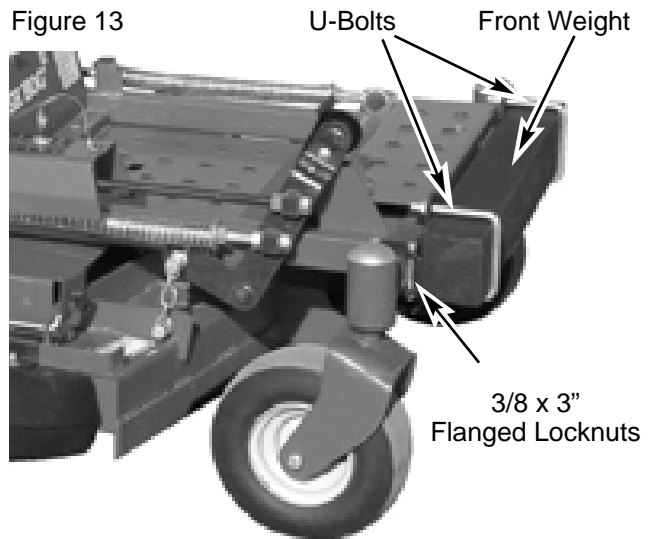

2-13 Installation/Removal Of Collection Bags

To install the bag onto the ring, first install ring end caps onto both ends of the ring. Place the seam openings of the bag onto the bag ring openings and slide the bag around the ring until the slot bracket in the bag ring is protruding through the opening in the bag. Do this for each of the three bags. (Figure 14)

Figure 14 Bag Installation

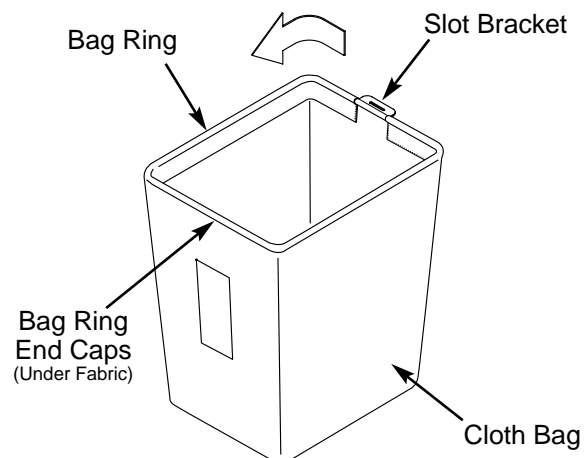

Install the completed assemblies onto the support frame and close the plastic top. Fasten both draw latches to hold the plastic top closed. (Figures 15 & 16)

To empty the bag, remove the bag ring by lifting and sliding rearward. Grasp the loop on the bottom of the bag, turn it upside down and empty the collected debris. Repeat for the other bags. Reinstall all bags and line with plastic bags if desired, close the plastic top and reattach the draw latches.

Plastic lawn and leaf bags, 33 gallon size, may be used inside the cloth bags. Be sure to leave enough plastic bag hanging over the frame so the plastic bag can be twist tied before emptying.

Figure 15 One Bag Removed



Figure 16

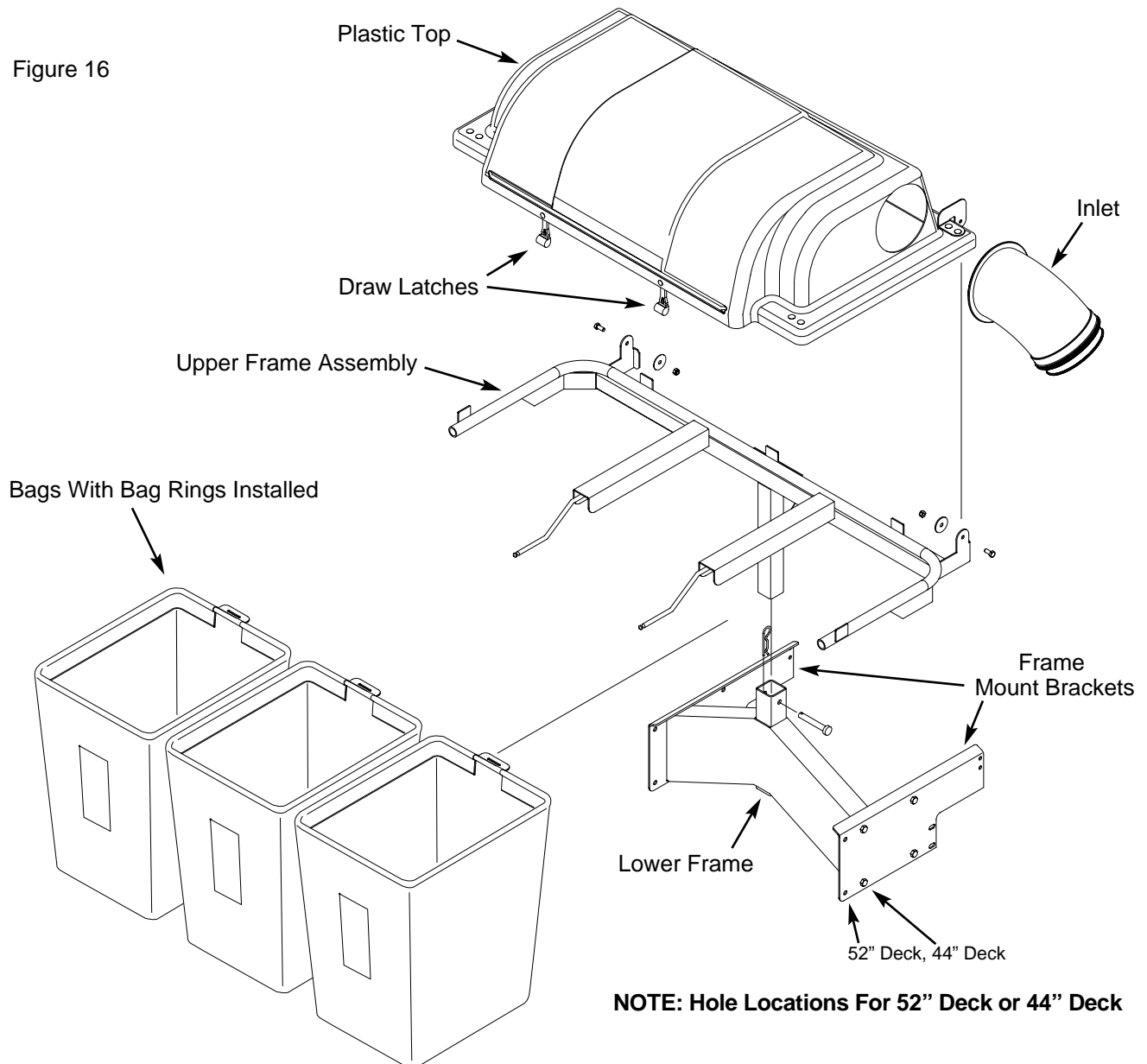

SECTION III OPERATING INSTRUCTIONS

3-1 General Safety

Only qualified people familiar with this operator's manual and the mower's operator's manual should operate this machine.

3-2 Operation And Tips On Mowing

- A. Perform BEFORE EACH USE maintenance list in paragraph 4-1.
- B. Start mower.
- C. While seated in the operator's seat, rotate the engagement handle of the collection system away from the mower. Continue to rotate the handle until it stops in an over center position. With the blower engaged, you can proceed to operate the control levers of the mower.
- D. With the mower at high speed, engage the mower deck.

NOTE: If the collection system does not appear to be collection the grass clippings, disengage the deck and blower, then engage the parking brake and turn the engine off. proceed to Section 3-3 and review Section 2-6 in this manual.

To obtain the maximum effectiveness from your collection system the tips listed below should be followed:

- * Watch your speed - Normal conditions will allow a speed of up to approximately 5 mph, but thick, heavy damp conditions will require reduced ground speed.
- * Mow with sharp blades - A sharp blade cuts cleaner.
- * Wet grass and leaves will decrease effectiveness and will increase horsepower requirements.
- * Mow at higher cutting heights - Remove and mulch no more than 2" of grass length with each mowing. (Experts recommend not cutting off more than 1/3 of the grass blade length at any given time.)
- * Mow twice, at different height settings, (high, then low), if grass is extra tall.
- * Remember that horsepower requirements will vary with the mowing conditions such as type and height of turf grass, moisture content, amount of leaves, whether the terrain is flat or hilly, etc.

3-3 Disengagement Of The Blower

- A. To disengage the blower, rotate the engagement handle towards the mower.

WARNING: To determine when the collection bags are full, follow the following steps:

- A. Stop the forward movement of the mower.
- B. Disengage the mower deck.
- C. Disengage the blower.
- D. Engage the parking brake.
- E. Once the parking brake has been engaged, and only then, walk behind the mower and check the collection bags by lifting the plastic top. The load in the bags should not exceed the height of the installed bags.
- F. To release bags from the frame, lift the bag ring from the tab on the bagger frame, slide the bag out and turn the bag over to deposit the clippings.
- G. Follow steps on page 14 to re-attach the bags back to the bagger.

NOTE: Do not allow collection bags to become over filled as potential damage may occur to your equipment. Also, be sure to clean the hood screen as needed.

SECTION IV MAINTENANCE

4-1 Maintenance Checklist

Before each use:

1. Check blades and spindles to be sure that no foreign objects, such as wire or steel strapping bands, are wrapped around them.
2. Inspect blades for wear. Replace if necessary. If it is necessary to sharpen blades, remove the blades from the spindles before sharpening. DO NOT sharpen blades while still attached to the mower.
3. Make sure all shields are in place and in good condition. Repair or replace any missing or damaged shields.
4. Perform lubrication per paragraph 4-2.
5. Listen for abnormal sounds, which might indicate loose parts, damaged bearings, or other damage. Correct any deficiency before continuing operation.
6. With the engine off, engage the blower assembly. Check the belt tension and inspect the pulley belt for cracks or tears.
7. Check for wear or deterioration of the upper or lower hoses. If there are any portions of the hose that have been torn or worn through, replace with genuine BUSH HOG parts.

After Each Use:

1. Clean all debris from machine especially from the container, underneath the belt shields and off of safety decals. Replace any missing or illegible decals.

2. Inspect the unit for worn or damaged components. Repair or replace before next use. Any replacement component installed during repair shall include the component's current safety decal specified by the manufacturers to be affixed to the component.
3. Check belt for proper tension.

4-2 Lubrication

NOTE: Use only white lithium base grease for lubrication of the shaft on the blower assembly.

1. On the initial use: Grease the fitting on the blower shaft.
2. Every 25 hours of use: Re-grease the grease fitting.
3. Every 200 hours of use: Check oil levels in gear box. Oil in gear box should cover the gears. If not, fill using an EP90 weight oil. 6 oz. will fill the gear box from empty.

Parts And Service Information

Bush Hog collection system owners should record the name and telephone number of their dealer. Your dealer will be happy to supply replacement parts, accessories and do any service or repairs to your collection system. If for any reason your dealer is unable to service your collection system or supply replacement parts, contact Bush Hog and include the following information from the serial number plate:

Model Number _____

Serial Number _____



SAFETY DECALS

To promote safe operation, Bush Hog supplies safety decals on all products manufactured. Because damage can occur to safety decals either through shipment, use or reconditioning, Bush Hog will, upon request, provide safety decals for any of our products in the field at no charge. Contact your authorized Bush Hog dealer for more information.



50031301



50031304



50031303



50031302



50052129



50052916



50052915

TORQUE SPECIFICATIONS

Proper torque for American fasteners used on Bush Hog equipment.
Recommended Torque in Foot Pounds (Newton Meters).*

AMERICAN

Bolt Head Markings

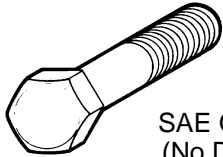

SAE Grade 2
(No Dashes)

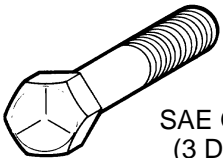

SAE Grade 5
(3 Dashes)

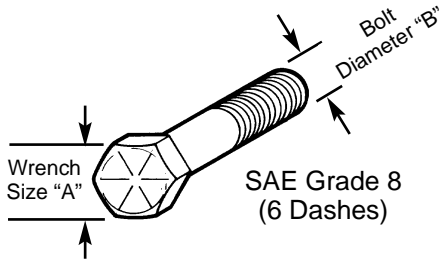

SAE Grade 8
(6 Dashes)

WRENCH SIZE (IN.) "A"	BOLT DIAMETER (IN.) "B" AND THREAD SIZE	SAE GRADE 2	SAE GRADE 5	SAE GRADE 8
7/16	1/4 - 20 UNC	6 (7)	8 (11)	12 (16)
7/16	1/4 - 28 UNF	6 (8)	10 (13)	14 (18)
1/2	5/16 - 18 UNC	11 (15)	17 (23)	25 (33)
1/2	5/16 - 24 UNF	13 (17)	19 (26)	27 (37)
9/16	3/8 - 16 UNC	20 (27)	31 (42)	44 (60)
9/16	3/8 - 24 UNF	23 (31)	35 (47)	49 (66)
5/8	7/16 - 14 UNC	32 (43)	49 (66)	70 (95)
5/8	7/16 - 20 UNF	36 (49)	55 (75)	78 (106)
3/4	1/2 - 13 UNC	49 (66)	76 (103)	106 (144)
3/4	1/2 - 20 UNF	55 (75)	85 (115)	120 (163)
7/8	9/16 - 12 UNC	70 (95)	109 (148)	153 (207)
7/8	9/16 - 18 UNF	79 (107)	122 (165)	172 (233)
15/16	5/8 - 11 UNC	97 (131)	150 (203)	212 (287)
15/16	5/8 - 18 UNF	110 (149)	170 (230)	240 (325)
1-1/8	3/4 - 10 UNC	144 (195)	266 (360)	376 (509)
1-1/8	3/4 - 16 UNF	192 (260)	297 (402)	420 (569)
1-5/16	7/8 - 9 UNC	166 (225)	430 (583)	606 (821)
1-5/16	7/8 - 14 UNF	184 (249)	474 (642)	668 (905)
1-1/2	1 - 8 UNC	250 (339)	644 (873)	909 (1232)
1-1/2	1 - 12 UNF	274 (371)	705 (955)	995 (1348)
1-1/2	1 - 14 UNF	280 (379)	721 (977)	1019 (1381)
1-11/16	1-1/8 - 7 UNC	354 (480)	795 (1077)	1288(1745)
1-11/16	1-1/8 - 12 UNF	397 (538)	890 (1206)	1444 (1957)
1-7/8	1-1/4 - 7 UNC	500 (678)	1120 (1518)	1817 (2462)
1-7/8	1-1/4 - 12 UNF	553 (749)	1241 (1682)	2013 (2728)
2-1/16	1-3/8 - 6 UNC	655 (887)	1470 (1992)	2382 (3228)
2-1/16	1-3/8 - 12 UNF	746 (1011)	1672 (2266)	2712 (3675)
2-1/4	1-1/2 - 6 UNC	870 (1179)	1950 (2642)	3161 (4283)
2-1/4	1-1/2 - 12 UNF	979 (1327)	2194 (2973)	3557 (4820)

METRIC

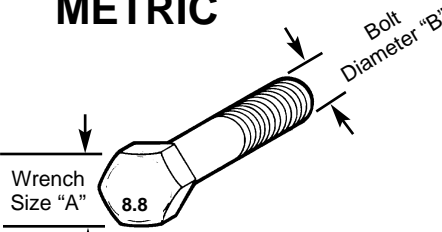

Numbers appearing on bolt heads indicate ASTM class.

Proper torque for metric fasteners used on Bush Hog equipment.
Recommended torque in foot pounds (newton Meters).*

WRENCH SIZE (mm) "A"	BOLT DIA. (mm) "B"	ASTM 4.6	ASTM 8.8	ASTM 9.8	ASTM 10.9
8	5	1.8 (2.4)		5.1 (6.9)	6.5 (8.8)
10	6	3 (4)		8.7 (12)	11.1 (15)
13	8	7.3 (10)		21.1 (29)	27 (37)
16	10	14.5 (20)		42 (57)	53 (72)
18	12	25 (34)	74 (100)	73 (99)	93 (126)
21	14	40 (54)	118 (160)	116 (157)	148 (201)
24	16	62 (84)	167 (226)	181 (245)	230 (312)
30	20	122 (165)	325 (440)		449 (608)
33	22		443 (600)		611 (828)
36	24	211 (286)	563 (763)		778 (1054)
41	27		821 (1112)		1138 (1542)
46	30	418 (566)	1119 (1516)		1547 (2096)

*Use 75% of the specified torque value for plated fasteners. Use 85% of the specified torque values for lubricated fasteners.



BUSH HOG[®], L.L.C.

P.O. Box 1039 • Selma, AL 36702-1039

Telephone (334) 874-2700 • www.bushhog.com