

**48TC
Gas Heat/Electric Cooling Packaged Rooftop
3 to 12.5 Nominal Tons**



Turn to the Experts.™

Product Data



C08514

(Unit shown with optional economizer.)



This product has been designed and manufactured to meet Energy Star® criteria for energy efficiency. However, proper refrigerant charge and proper air flow are critical to achieve rated capacity and efficiency. Installation of this product should follow all manufacturer's refrigerant charging and air flow instructions. **Failure to confirm proper charge and air flow may reduce energy efficiency and shorten equipment life.**

TABLE OF CONTENTS

	PAGE		PAGE
FEATURES AND BENEFITS	3	COOLING TABLES	25
MODEL NUMBER NOMENCLATURE	4	STATIC PRESSURE ADDERS	35
FACTORY OPTIONS AND/OR ACCESSORIES	6	FAN PERFORMANCE	36
ARI COOLING RATING TABLES	8	OUTDOOR AIR INTAKE & EXHAUST PERF	48
HEAT RATING TABLE	9	ELECTRICAL INFORMATION	49
SOUND PERFORMANCE TABLE	10	MCA / MOCP	53
PHYSICAL DATA	12	TYPICAL WIRING DIAGRAMS	57
CURBS & WEIGHTS DIMENSIONS	16	SEQUENCE OF OPERATION	61
APPLICATION DATA	22	GUIDE SPECIFICATIONS	63

48TC



Turn to the Experts.™

Your Carrier rooftop unit (RTU) was designed by customers for customers. With “no-strip screw” collars, handled access panels, and more we’ve made your unit easy to install, easy to maintain and easy to use.

Easy to install:

All WeatherMaker® units are field-convertible to horizontal air flow; no special adapter curbs or kits are necessary. Convertible airflow design makes it easy to adjust to unexpected job-site complications. Lighter units make easy replacement. Carrier 3-12.5 ton 48TC rooftops fit on existing Carrier curbs dating back to 1989. Also, our large control box gives you room to work and room to mount Carrier accessory controls.

Easy to maintain:

Easy access handles by Carrier provide quick and easy access to all normally serviced components. Our “no-strip” screw system has superior holding power and guides screws into position while preventing the screw from stripping the unit’s metal. Take accurate pressure readings by reading condenser pressure with panels on. Simply remove the black, composite plug, route your gauge line(s) through the hole, and connect them to the refrigeration service valve(s). Now, you can take refrigeration system pressure readings without affecting the condenser airflow.

Easy to use:

The newly designed, master terminal board by Carrier puts all your connections and troubleshooting points in one convenient place, standard. Most low voltage connections are made to the same board and make it easy to find what you’re looking for and easy to access it. Carrier rooftops have high and low pressure switches, a filter drier, and 2” (51mm) filters standard.



This product has been designed and manufactured to meet Energy Star® criteria for energy efficiency. However, proper refrigerant charge and proper air flow are critical to achieve rated capacity and efficiency. Installation of this product should follow all manufacturer’s refrigerant charging and air flow instructions. **Failure to confirm proper charge and air flow may reduce energy efficiency and shorten equipment life.**



FEATURES AND BENEFITS

- Single cooling stage models are available from 3 - 10 ton.
- Two cooling stage models are available from 7.5 - 12.5 ton with NOVATION™ condenser coil technology.
- SEER up to 13.0.
- EER's up to 11.2.
- IPLV's up to 12.2.
- Up to 28% lighter than similar industry units. Lighter rooftops make easier replacement jobs.
- Utility connections are the same because 3-12.5 ton units fit on existing Carrier rooftop curbs. This saves time and money on replacement jobs.
- Standardized components and layout. Standardized components and controls make service and stocking parts easier.
- Scroll compressors on all units. This makes service, stocking parts, replacement, and trouble-shooting easier.
- Field convertible airflow (3-12.5 ton). Being able to convert a unit from vertical airflow to horizontal makes it easy to overcome job site complications.
- Easy-adjust, belt-drive motor available. Carrier provides a factory solution for most points in the fan performance table. There's no need for field-supplied drives or motors.
- Provisions for bottom or side condensate drain.
- Capable of thru-the-base or thru-the-curb gas-line routing.
- Single-point gas / electrical connection.
- Sloped, composite drain pan. Sloped, composite drain pan sheds water; and won't rust.
- Standardized controls and control box layout. Standardized components and controls make stocking parts and service easier.
- Tool-less filter access door.
- Clean, easy to use control box.
- Color-coded wiring.
- Large, laminated wiring and power wiring drawings which are affixed to unit make troubleshooting easy.
- Single, central terminal board for test and wiring connections.
- Fast-access, handled, panels for easy access on normally accessed service panels.
- "No-strip" screw system guides screws into the panel and captures them tightly without stripping the screw, the panel, or the unit.
- Exclusive, newly-design indoor refrigerant header for easier maintenance and replacement.
- Mechanical cooling (115°F to 25°F or 46°C to -4°C) on Direct Digital Controller (DDC) with Winter Start Kit (PremierLink™ or RTU-MP controller).
- Mechanical cooling (115°F to 25°F or 46°C to -4°C) on Electro-Mechanical (E/M) models, with Winter Start Kit.
- High efficiency, gas heat with induced-draft flue exhaust design (3-12.5 tons).
- Induce draft motor ensures no flue gas can escape into the indoor air stream.
- Carrier designed naturally draining heat exchanger, unlike positive pressure heat exchangers, do not need to be periodically, manually drained. This saves labor and maintenance expense.
- 2" (51mm) disposable filters on all units.
- Refrigerant filter-drier on each circuit.
- High and low pressure switches. Added reliability with high pressure switch and low pressure switch.
- Many factory-installed options ranging from air management economizers, 2 position dampers, plus convenience outlets, disconnect switch and smoke detectors.
- Standard Warranty: 10 year aluminized heat exchanger, 5 year compressor, 3 year NOVATION™ condenser coil, 1 year parts.
- Factory-installed Humidi-MiZer™ adaptive dehumidification system.

MODEL NUMBER NOMENCLATURE

1	2	3	4	5	6	7	8	9	10	11	12	13	14	15	16	17	18
4	8	T	C	D	A	0	4	A	1	A	5	-	0	A	0	A	0

48TC

Unit Heat Type

48 = Cooling/Gas Heat RTU

Tier / Model

TC = Entry tier (with Puron refrigerant)

Heat Size

- D = Low heat
- E = Medium heat
- F = High heat
- L = Low NO_x, low heat
- M = Low NO_x, medium heat
- N = Low NO_x, high heat
- S = Stainless steel, low heat
- R = Stainless steel, medium heat
- T = Stainless steel, high heat

Refrig. System Options

- A = Standard 1-stage cooling
- B = Standard 1-stage cooling w/Humidi-MiZer
- D = 2-stg. cooling comp. w/NOVATION™ coil

Cooling Tons

- | | |
|------------|---------------|
| 04 = 3 Ton | 08 = 7.5 Ton |
| 05 = 4 Ton | 09 = 8.5 Ton |
| 06 = 5 Ton | 12 = 10 Ton |
| 07 = 6 Ton | 14 = 12.5 Ton |

Sensor Options

- A = None
- B = RA smoke detector
- C = SA smoke detector
- D = RA & SA smoke detector
- E = CO₂ sensor
- F = RA smoke detector & CO₂
- G = SA smoke detector & CO₂
- H = RA & SA smoke detector & CO₂

Indoor Fan Options

- 1 = Standard static option
- 2 = Medium static option
- 3 = High static option

Brand / Packaging

- 0 = Standard
- 1 = LTL

Electrical Options

- A = None
- C = Non-fused disc
- D = Thru the base
- F = Non-fused & thru the base

Service Options

- 0 = None
- 1 = Unpowered convenience outlet
- 2 = Powered convenience outlet

Intake / Exhaust Options

- A = None
- B = Temp econo w/ baro relief
- F = Enthalpy econo w/ baro relief
- K = 2-Position damper

Base Unit Controls

- 0 = Electromechanical
- 1 = PremierLink DDC controller
- 2 = RTU-MP multi protocol controller

Design Rev

Factory assigned

Voltage

- 1 = 575/3/60
- 3 = 208-230/1/60
- 5 = 208-230/3/60
- 6 = 460/3/60

1-Stage Cooling Coil Options (Outdoor - Indoor)

- A = Al/Cu - Al/Cu
- B = Precoat Al/Cu - Al/Cu
- C = E coat Al/Cu - Al/Cu
- D = E coat Al/Cu - E coat Al/Cu
- E = Cu/Cu - Al/Cu
- F = Cu/Cu - Cu/Cu
- M = Al/Cu - Al/Cu - Louvered Hail Guards
- N = Precoat Al/Cu - Al/Cu - Louvered Hail Guards
- P = E coat Al/Cu - Al/Cu - Louvered Hail Guards
- Q = E coat Al/Cu - E coat Al/Cu - Louvered Hail Guards
- R = Cu/Cu - Al/Cu - Louvered Hail Guards
- S = Cu/Cu - Cu/Cu - Louvered Hail Guards

2-Stage Cooling Coil Options (Outdoor - Indoor)

- G = Al/Al - Al/Cu
- H = Al/Al - Cu/Cu
- J = Al/Al - E-coat Al/Cu
- K = E-coat Al/Al - Al/Cu
- L = E-coat Al/Al - E-coat Al/Cu
- T = Al/Al - Al/Cu - Louvered Hail Guards
- U = Al/Al - Cu/Cu - Louvered Hail Guards
- V = Al/Al - E-coat Al/Cu - Louvered Hail Guards
- W = E-coat Al/Al - Al/Cu - Louvered Hail Guards
- X = E-coat Al/Al - E-coat Al/Cu - Louvered Hail Guards

TABLE 1 – FACTORY-INSTALLED OPTIONS AND FIELD-INSTALLED ACCESSORIES

CATEGORY	ITEM	FACTORY INSTALLED OPTION	FIELD INSTALLED ACCESSORY
Cabinet	Thru-the-base electrical or gas-line connections	X	X
Coil Options	Cu/Cu indoor and/or outdoor coils ¹	X	
	Pre-coated outdoor coils ¹	X	
	Premium, E-coated outdoor coils ¹	X	
Humidity Control	Humdi-MiZer™ Adaptive Dehumidification System	X	
Condenser Protection	Condenser coil hail guard (louvered design)	X	X
Controls	Thermostats, temperature sensors, and subbases		X
	PremierLink DDC communicating controller	X	X
	RTU-MP open-protocol controller	X	
	Smoke detector (supply and/or return air)	X	
	Time Guard II compressor delay control circuit		X
	Phase Monitor		X
Economizers & Outdoor Air Dampers	EconoMiSer™ IV (for electro-mechanical controlled RTUs)	X	X
	EconoMiSer™ 2 (for DDC controlled RTUs)	X	X
	Motorized 2 position outdoor-air damper	X	X
	Manual outdoor-air damper (25% and 50%)		X
	Barometric relief ²	X	X
	Power exhaust		X
Economizer Sensors & IAQ Devices	Single dry bulb temperature sensors ³	X	X
	Differential dry bulb temperature sensors ³		X
	Single enthalpy sensors ³	X	X
	Differential enthalpy sensors ³		X
	Wall or duct mounted CO ₂ sensor ³		X
	Unit mounted CO ₂ sensor ³	X	
Gas Heat	Propane conversion kit		X
	Stainless steel heat exchanger	X	
	High altitude conversion kit		X
	Flue Shield		X
	Flue Discharge Deflector		X
Indoor Motor & Drive	Multiple motor and drive packages	X	
Low Ambient Control	Winter start kit ⁴		X
	Motormaster® head pressure controller ⁴		X
Power Options	Convenience outlet (powered)	X	
	Convenience outlet (unpowered)	X	
	Non-fused disconnect	X	
Roof Curbs	Roof curb 14" (356mm)		X
	Roof curb 24" (610mm)		X

48TC

NOTES:

1. NOVATION™ coils (2-stage cooling models 08-14): Condenser Coil = E-coat, Indoor Coil = Cu/Cu or E-coat
2. Included with economizer.
3. Sensors used to optimize economizer performance.
4. See application data for assistance.

FACTORY OPTIONS AND/OR ACCESSORIES

Economizer (dry-bulb or enthalpy)

Economizers save money. They bring in fresh, outside air for ventilation; and provide cool, outside air to cool your building. This is the preferred method of low-ambient cooling. When coupled to CO₂ sensors, economizers can provide even more savings by coupling the ventilation air to only that amount required.

Economizers are available, installed and tested by the factory, with either enthalpy or dry-bulb temperature inputs. There are also models for electromechanical as well as direct digital controllers. Additional sensors are available as accessories to optimize the economizers.

Economizers include gravity controlled, barometric relief equalizes building pressure and ambient air pressures. This can be a cast effective solution to prevent building pressurization.

CO₂ Sensor

Improves productivity and saves money by working with the economizer to intake only the correct amount of outside air for ventilation. As occupants fill your building, the CO₂ sensor detects their presence through increasing CO₂ levels, and opens the economizer appropriately.

When the occupants leave, the CO₂ levels decrease, and the sensor appropriately closes the economizer. This intelligent control of the ventilation air, called Demand Control Ventilation (DCV) reduces the overall load on the rooftop, saving money.

Smoke Detectors

Trust the experts. Smoke detectors make your application safer and your job easier. Carrier smoke detectors immediately shut down the rooftop unit when smoke is detected. They are available, installed by the factory, for supply air, return air, or both.

Louvered Hail Guards

Sleek, louvered panels protect the condenser coil from hail damage, foreign objects, and incidental contact.

Convenience Outlet (powered or un-powered)

Reduce service and/or installation costs by including a convenience outlet in your specification. Carrier will install this service feature at our factory. Provides a convenient, 15 amp, 115v GFCI receptacle with “Wet in Use” cover. The “powered” option allows the installer to power the outlet from the line side of the disconnect or load side as required by code. The “unpowered” option is to be powered from a separate 115/120v power source.

Non-fused Disconnect

This OSHA-compliant, factory-installed, safety switch allows a service technician to locally secure power to the rooftop.

Power Exhaust with Barometric Relief

Superior internal building pressure control. This field-installed accessory may eliminate the need for costly, external pressure control fans.

PremierLink, DDC Controller

This CCN controller regulates your rooftop’s performance to tighter tolerances and expanded limits, as well as facilitates zoning systems and digital accessories. It also unites your Carrier HVAC equipment together on one, coherent CCN network. The PremierLink can be factory-installed, or easily field-installed.

RTU-MP, Multi-Protocol Controller

Connect the rooftop to an existing BAS without needing complicated translators or adapter modules using the RTU-MP controller. This new controller speaks the 4 most common building automation system languages (Bacnet, Modbus, N2, and Lonworks). Use this controller when you have an existing BAS.

Time Guard II Control Circuit

This accessory protects your compressor by preventing short-cycling in the event of some other failure, prevents the compressor from restarting for 30 seconds after stopping. Not required with PremierLink, RTU-MP, or authorized commercial thermostats.

Motorized 2-Position Damper

The new Carrier 2-position, motorized outdoor air damper admits up to 100% outside air. Using reliable, gear-driven technology, the 2-position damper opens to allow ventilation air and closes when the rooftop stops, stopping unwanted infiltration.

Manual OA Damper

Manual outdoor air dampers are an economical way to bring in ventilation air. The dampers are available in 25% and 50% versions.

Optional Humidi-MiZer™ Adaptive Dehumidification System

Carrier’s Humidi-MiZer adaptive dehumidification system is an all-inclusive factory-installed option that can be ordered with any WeatherMaker 48TC-04-07 rooftop unit.

This system expands the envelope of operation of Carrier’s WeatherMaker rooftop products to provide unprecedented flexibility to meet year-round comfort conditions.

The Humidi-MiZer adaptive dehumidification system has the industry’s only dual dehumidification mode setting. The Humidi-MiZer system includes two new modes of operation.

The WeatherMaker 48TC-04-07 rooftop coupled with the Humidi-MiZer system is capable of operating in normal design cooling mode, subcooling mode, and hot gas reheat mode. Normal design cooling mode is when the unit will operate under its normal sequence of operation by cycling compressors to maintain comfort conditions.

Subcooling mode will operate to satisfy part load type conditions when the space requires combined sensible and a higher proportion of latent load control. Hot Gas Reheat mode will operate when outdoor temperatures diminish and the need for latent capacity is required for sole humidity control. Hot Gas Reheat mode will provide neutral air for maximum dehumidification operation.

Motormaster Head Pressure Controller

The Motormaster motor controller is a low ambient, head pressure controller kit that is designed to maintain the unit's condenser head pressure during periods of low ambient cooling operation. This device should be used as an alternative to economizer free cooling not when economizer usage is either not appropriate or desired. The Motormaster will either cycle the outdoor-fan motors or operate them at reduced speed to maintain the unit operation, depending on the model.

Winter Start Kit

The winter start kit by Carrier extends the low ambient limit of your rooftop to 25°F (-4°C). The kit bypasses the low pressure switch, preventing nuisance tripping of the low pressure switch. Other low ambient precautions may still be prudent.

Propane Heating

Convert your gas heat rooftop from standard natural gas operation to Propane using this field-installed kit.

High Altitude Heating

High altitudes have less oxygen, which means heat exchangers need less fuel. The new gas orifices in this field-installed kit make the necessary adjustment for high altitude applications. They restore the optimal fuel to air mixture and maintain healthy combustion at altitudes above 2000 ft (610m). Kits may not be required in all areas.

Flue Discharge Deflector

The flue discharge deflector is a useful accessory when flue gas recirculation is a concern. By venting the flue discharge upwards, the deflector minimizes the chance for a neighboring unit to intake the flue exhaust.

Optional Stainless Steel Heat Exchanger

The stainless steel heat exchanger option provides the tubular heat exchanger be made out of a minimum 20 gauge type 409 stainless steel for applications where the mixed air to the heat exchanger is expected to drop below 45°F (7°C). Stainless steel may be specified on applications where the presence of airborne contaminants require its use (applications such as paper mills) or in area with very high outdoor humidity that may result in severe condensation in the heat exchanger during cooling operation.

Flue Discharge Heat Shield

The flue discharge heat shield keeps people from touching the rooftop unit's potentially hot flue discharge. This is especially useful for ground level applications, where more, untrained people could have access to the unit's exterior.

Alternate Motors and Drives

Some applications need larger horsepower motors, some need more airflow, and some need both. Regardless of the case, your Carrier expert has a factory installed combination to meet your application. A wide selection of motors and pulleys (drives) are available, factory installed, to handle nearly any application.

Thru-the-Base Connections

Thru-the-base connections, available as either an accessory or as a factory option, are necessary to ensure proper connection and seal when routing wire and piping through the rooftop's basepan and curb. These couplings eliminate roof penetration and should be considered for gas lines, main power lines, as well as control power.

TABLE 2 – ARI COOLING RATING TABLE 1-STAGE COOLING

UNIT	COOLING STAGES	NOM. CAPACITY (TONS)	NET COOLING CAPACITY (MBH)	TOTAL POWER (KW)	SEER	EER	IPLV
A04	1	3	34.6	3.1	13.00	11.00	N/A
A05	1	4	45.0	4.0	13.00	11.00	N/A
A06	1	5	59.0	5.5	13.00	10.75	N/A
A07	1	6	70.0	6.4	N/A	11.00	N/A
A08	1	7.5	88.0	8.0	N/A	11.00	N/A
A09	1	8.5	97.0	8.8	N/A	11.00	N/A
A12	1	10	117.0	10.6	N/A	11.00	N/A

TABLE 3 – ARI COOLING RATING TABLE 2-STAGE COOLING

UNIT	COOLING STAGES	NOM. CAPACITY (TONS)	NET COOLING CAPACITY (MBH)	TOTAL POWER (KW)	SEER	EER	IPLV
D08	2	7.5	83.0	7.5	N/A	11.00	12.0
D12	2	10	114.0	10.3	N/A	11.10	12.2
D14	2	12.5	140.0	12.9	N/A	10.80	11.4

48TC

LEGEND

- ARI – Air Conditioning, Heating and Refrigeration Institute Test Standard
- ASHRAE – American Society of Heating, Refrigerating and Air Conditioning, Inc.
- EER – Energy Efficiency Ratio
- IPLV – Integrated Part Load Value
- SEER – Seasonal Energy Efficiency Ratio

NOTES:

1. Rated and certified under ARI Standard 210/240–06 or 340/360–07, as appropriate.
2. Ratings are based on:
Cooling Standard: 80°F (27°C) db, 67°F (19°C) wb indoor air temp and 95°F (35°C) db outdoor air temp.
IPLV Standard: 80°F (27°C) db, 67°F (19°C) wb indoor air temp and 80°F (27°C) db outdoor air temp.
3. All 48TC units comply with ASHRAE 90.1 2001, 2004 Energy Standard for minimum SEER and EER requirements.
4. 48TC units comply with US Energy Policy Act (2005). To evaluate code compliance requirements, refer to state and local codes or visit the following website: <http://bcap-energy.org>.



ARI Standard
210/240 UAC



ARI Standard
340/360



This product has been designed and manufactured to meet Energy Star® criteria for energy efficiency. However, proper refrigerant charge and proper air flow are critical to achieve rated capacity and efficiency. Installation of this product should follow all manufacturer's refrigerant charging and air flow instructions. Failure to confirm proper charge and air flow may reduce energy efficiency and shorten equipment life.

TABLE 4 – HEATING RATING TABLE - NATURAL GAS & PROPANE

Units	Gas Heat	AL/SS HEAT EXCHANGER		TEMP RISE (DEG F)	THERMAL EFFICIENCY (%)	AFUE (%)	
		INPUT / OUTPUT STAGE 1 (MBH)	INPUT / OUTPUT STAGE 2 (MBH)				
Single Phase	04	LOW	–	72 / 59	25 – 55	82%	81%
		MED	–	115 / 93	55 – 85	80%	80%
		HIGH	–	–	–	–	–
	05	LOW	–	72 / 59	25 – 55	82%	81%
		MED	–	115 / 93	35 – 65	81%	80%
		HIGH	–	150 / 120	50 – 80	80%	80%
	06	LOW	–	72 / 59	20 – 55	82%	81%
		MED	–	115 / 93	30 – 65	81%	80%
		HIGH	–	150 / 120	40 – 80	80%	80%
Three Phase	04	LOW	–	72 / 59	25 – 55	82%	N/A
		MED	82 / 66	115 / 93	55 – 85	80%	N/A
		HIGH	–	–	–	–	–
	05	LOW	–	72 / 59	25 – 55	82%	N/A
		MED	–	115 / 93	35 – 65	81%	N/A
		HIGH	120 / 96	150 / 120	50 – 80	80%	N/A
	06	LOW	–	72 / 59	20 – 55	82%	N/A
		MED	–	115 / 93	30 – 65	81%	N/A
		HIGH	120 / 96	150 / 120	40 – 80	80%	N/A
	07	LOW	–	72 / 59	15 – 55	82%	N/A
		MED	–	115 / 93	25 – 65	81%	N/A
		HIGH	120 / 96	150 / 120	35 – 80	80%	N/A
	08	LOW	–	125 / 103	20 – 50	82%	N/A
		MED	120 / 98	180 / 148	35 – 65	82%	N/A
		HIGH	180 / 147	224 / 184	45 – 75	82%	N/A
	09	LOW	–	125 / 103	20 – 50	82%	N/A
		MED	120 / 98	180 / 148	30 – 65	82%	N/A
		HIGH	180 / 147	224 / 184	40 – 75	82%	N/A
12	LOW	120 / 98	180 / 148	25 – 65	82%	N/A	
	MED	180 / 147	224 / 184	30 – 65	82%	N/A	
	HIGH	200 / 160	250 / 205	35 – 70	80%	N/A	
14	LOW	120 / 98	180 / 148	20 – 65	82%	N/A	
	MED	180 / 147	224 / 184	25 – 65	82%	N/A	
	HIGH	200 / 160	250 / 205	25 – 70	80%	N/A	

NOTES:

Heat ratings are for natural gas heat exchangers operated at or below 2000 ft (610 m). For information on Propane or altitudes above 2000 ft (610 m), see the Application Data section of this book. Accessory Propane/High Altitude kits are also available.

In the USA the input rating for altitudes above 2000 ft (610m) must be derated by 4% for each 1000 ft (305 m) above sea level. In Canada, the input rating must be derated by 10% for altitudes of 2000 ft (610 m) to 4500 ft (1372 m) above sea level.

48TC

TABLE 5 – HEATING RATING TABLE - LOW NO_x¹

UNIT	GAS HEAT	LOW NO _x HEAT EXCHANGER		TEMP RISE (DEG F)	THERMAL EFFICIENCY (%)	AFUE (%)		
		INPUT / OUTPUT STAGE 1 (MBH)	INPUT / OUTPUT STAGE 2 (MBH)					
Single Phase	04	LOW	–	60 / 50	20 – 50	81%	80%	
		MED	–	90 / 74	30 – 60	81%	81%	
		HIGH	–	–	–	–	–	–
	05	LOW	–	60 / 50	20 – 50	81%	81%	80%
		MED	–	90 / 74	30 – 60	81%	81%	81%
		HIGH	–	120 / 101	40 – 70	81%	81%	80%
	06	LOW	–	60 / 50	15 – 50	81%	81%	80%
		MED	–	90 / 74	25 – 60	80%	80%	81%
		HIGH	–	120 / 101	35 – 70	80%	80%	81%
Three Phase	04	LOW	–	60 / 50	20 – 50	81%	80%	
		MED	–	90 / 74	30 – 60	81%	81%	
		HIGH	–	–	–	–	–	–
	05	LOW	–	60 / 50	20 – 50	81%	81%	80%
		MED	–	90 / 74	30 – 60	81%	81%	81%
		HIGH	–	120 / 101	40 – 70	81%	81%	80%
	06	LOW	–	60 / 50	15 – 50	81%	81%	80%
		MED	–	90 / 74	25 – 60	80%	80%	81%
		HIGH	–	120 / 101	35 – 70	80%	80%	81%

48TC

NOTE:

- Units meet California’s South Coast Air Quality Management District (SCAQMD) Low–NO_x emissions requirement of 40 nanograms per joule or less.

TABLE 6 – SOUND PERFORMANCE TABLE

UNIT	COOLING STAGES	OUTDOOR SOUND (dB)								
		A–WEIGHTED	63	125	250	500	1000	2000	4000	8000
A04	1	80	90.6	80.9	80.2	76	74.6	71.3	68.5	63.9
A05	1	81	90.9	84.6	79.5	77.9	76.5	71.1	66.9	62.5
A06	1	78	84.0	82.2	76.3	74.8	72.5	68.8	65.6	61.8
A07	1	78	88.8	81.8	76.9	74.4	73.3	69.8	66.3	62.7
A08	1	82	90.1	82.6	81.0	79.4	77.0	73.0	70.4	66.7
D08	2	82	85.8	84.3	80.5	78.7	76.4	72.7	68.3	65.1
A09	1	83	91.2	86.4	81.9	81.0	78.3	73.9	71.4	67.3
A12	1	82	88.6	85.0	81.6	79.5	77.4	74.1	71.0	66.3
D12	2	82	89.0	83.1	80.5	78.5	75.5	71.6	69.6	69.3
D14	2	87	87.0	85.2	84.6	84.9	82.2	78.4	75.3	72.9

LEGEND

dB – Decibel



NOTES:

- Outdoor sound data is measure in accordance with ARI standard 270–2008.
- Measurements are expressed in terms of sound power. Do not compare these values to sound pressure values because sound pressure depends on specific environmental factors which normally do not match individual applications. Sound power values are independent of the environment and therefore more accurate.
- A–weighted sound ratings filter out very high and very low frequencies, to better approximate the response of “average” human ear. A–weighted measurements for Carrier units are taken in accordance with ARI standard 270–2008.

TABLE 7 – MINIMUM - MAXIMUM AIRFLOW RATINGS - NATURAL GAS & PROPANE

UNIT	HEAT LEVEL	COOLING		HEATING	
		MINIMUM	MAXIMUM	MINIMUM	MAXIMUM
48TC**04	LOW	900	1500	990	2190
	MED			1000	1550
	HIGH			-	-
48TC**05	LOW	1200	2000	990	2190
	MED			1330	2460
	HIGH			1390	2220
48TC**06	LOW	1500	2500	990	2730
	MED			1330	2880
	HIGH			1390	2780
48TC**07	LOW	1800	3000	990	3640
	MED			1330	3450
	HIGH			1390	3170
48TC**08	LOW	2250	3750	1900	4750
	MED			2100	3900
	HIGH			2270	3780
48TC**09	LOW	2550	4250	1900	4750
	MED			2100	4560
	HIGH			2270	4250
48TC**12	LOW	3000	5000	2100	5470
	MED			2620	5670
	HIGH			2650	5290
48TC**14	LOW	3600	6000	2100	6830
	MED			2620	6800
	HIGH			2650	7410

48TC

TABLE 8 – PHYSICAL DATA

(COOLING)

3 - 6 TONS

		48TC*A04	48TC*A05	48TC*A06	48TC*A07
Refrigeration System					
# Circuits / # Comp. / Type		1 / 1 / Scroll	1 / 1 / Scroll	1 / 1 / Scroll	1 / 1 / Scroll
Puron® refrig. (R-410A) charge per circuit A/B (lbs-oz)		5-10 / -	8-8 / -	10-11 / -	14-2 / -
Operating charge (lbs-oz) – Humidi-MiZer Unit		8-12	14-13	16-0	22-4
Metering Device		Acutrol	Acutrol	Acutrol	Acutrol
High-press. Trip / Reset (psig)		630 / 505	630 / 505	630 / 505	630 / 505
Low-press. Trip / Reset (psig)		54 / 117	54 / 117	54 / 117	54 / 117
Evap. Coil					
Material		Cu / Al	Cu / Al	Cu / Al	Cu / Al
Coil type		3/8" RTPF	3/8" RTPF	3/8" RTPF	3/8" RTPF
Rows / FPI		2 / 15	2 / 15	4 / 15	4 / 15
Total Face Area (ft ²)		5.5	5.5	5.5	7.3
Condensate Drain Conn. Size		3/4"	3/4"	3/4"	3/4"
Evap. Fan and Motor					
Standard Static 1 phase	Motor Qty / Drive Type	1 / Belt	1 / Belt	1 / Belt	-
	Max BHP	1.2	1.2	1.2	-
	RPM Range	560-854	560-854	770-1175	-
	Motor Frame Size	48	48	48	-
	Fan Qty / Type	1 / Centrifugal	1 / Centrifugal	1 / Centrifugal	-
	Fan Diameter (in)	10 x 10	10 x 10	10 x 10	-
Medium Static 1 phase	Motor Qty / Drive Type	1 / Belt	1 / Belt	1 / Belt	-
	Max BHP	1.2	1.2	1.5	-
	RPM Range	770-1175	770-1175	1035-1466	-
	Motor Frame Size	48	48	56	-
	Fan Qty / Type	1 / Centrifugal	1 / Centrifugal	1 / Centrifugal	-
	Fan Diameter (in)	10 x 10	10 x 10	10 x 10	-
Standard Static 3 phase	Motor Qty / Drive Type	1 / Belt	1 / Belt	1 / Belt	1 / Belt
	Max BHP	1.2	1.2	1.5	2.4
	RPM Range	560-854	560-854	770-1175	1073-1457
	Motor Frame Size	48	48	48	56
	Fan Qty / Type	1 / Centrifugal	1 / Centrifugal	1 / Centrifugal	1 / Centrifugal
	Fan Diameter (in)	10 x 10	10 x 10	10 x 10	10 x 10
Medium Static 3 phase	Motor Qty / Drive Type	1 / Belt	1 / Belt	1 / Belt	1 / Belt
	Max BHP	1.2	1.2	2.4	2.9*
	RPM Range	770-1175	770-1175	1035-1466	1173-1518
	Motor Frame Size	48	48	56	56
	Fan Qty / Type	1 / Centrifugal	1 / Centrifugal	1 / Centrifugal	1 / Centrifugal
	Fan Diameter (in)	10 x 10	10 x 10	10 x 10	10 x 10
High Static 3 phase	Motor Qty / Drive Type	1 / Belt	1 / Belt	1 / Belt	1 / Belt
	Max BHP	2.4	2.4	2.9	3.7
	RPM Range	1035-1466	1035-1466	1303-1687	1474-1788
	Motor Frame Size	56	56	56	56
	Fan Qty / Type	1 / Centrifugal	1 / Centrifugal	1 / Centrifugal	1 / Centrifugal
	Fan Diameter (in)	10 x 10	10 x 10	10 x 10	10 x 10
Cond. Coil					
Material		Cu / Al	Cu / Al	Cu / Al	Cu / Al
Coil type		3/8" RTPF	3/8" RTPF	3/8" RTPF	3/8" RTPF
Rows / FPI		1 / 17	2 / 17	2 / 17	2 / 17
Total Face Area (ft ²)		14.6	16.5	16.5	21.3
Humidi-MiZer Coil					
Material		Cu / Al	Cu / Al	Cu / Al	Cu / Al
Rows..Fins/in.		1 / 17	2 / 17	2 / 17	2 / 17
Total Face Area (ft ²)		3.9	3.9	3.9	5.2
Cond. fan / motor					
Qty / Motor Drive Type		1/ Direct	1/ Direct	1/ Direct	1/ Direct
Motor HP / RPM		1/4 / 1100	1/4 / 1100	1/4 / 1100	1/4 / 1100
Fan diameter (in)		22	22	22	22
Filters					
RA Filter # / Size (in)		2 / 16 x 25 x 2	2 / 16 x 25 x 2	2 / 16 x 25 x 2	4 / 16 x 16 x 2
OA inlet screen # / Size (in)		1 / 20 x 24 x 1	1 / 20 x 24 x 1	1 / 20 x 24 x 1	1 / 20 x 24 x 1

48TC

* 575V motor utilizes 3.7 BHP.

TABLE 9 – PHYSICAL DATA

(HEATING)

3 - 6 TONS

		48TC**04	48TC**05	48TC**06	48TC**07
Gas Connection					
	# of Gas Valves	1	1	1	1
	Nat. gas supply line press (in. w.g.)/(PSIG)	4 – 13 / 0.18 – 0.47	4 – 13 / 0.18 – 0.47	4 – 13 / 0.18 – 0.47	4 – 13 / 0.18 – 0.47
	Propane supply line press (in. w.g.)/(PSIG)	11 – 13 / 0.40 – 0.47	11 – 13 / 0.40 – 0.47	11 – 13 / 0.40 – 0.47	11 – 13 / 0.40 – 0.47
Heat Anticipator Setting (Amps)					
	1st stage	0.14	0.14	0.14	0.14
	2nd stage	0.14	0.14	0.14	0.14
Natural Gas, Propane Heat					
LOW	# of stages / # of burners (total)	1 / 2	1 / 2	1 / 2	1 / 2
	Connection size	1/2" NPT	1/2" NPT	1/2" NPT	1/2" NPT
	Rollout switch opens / closes	195 / 115	195 / 115	195 / 115	195 / 115
	Temperature rise range (F)	25 – 55	25 – 55	20 – 55	15 – 55
MED	# of stages / # of burners (total)	1 or 2 / 3	1 / 3	1 / 3	1 / 3
	Connection size	1/2" NPT	1/2" NPT	1/2" NPT	1/2" NPT
	Rollout switch opens / closes	195 / 115	195 / 115	195 / 115	195 / 115
	Temperature rise range (F)	55 – 85	35 – 65	30 – 65	25 – 65
HIGH	Connection size	–	1 or 2 / 3	1 or 2 / 3	1 or 2 / 3
	# of stages / # of burners (total)	–	1/2" NPT	1/2" NPT	1/2" NPT
	Rollout switch opens / closes	–	195 / 115	195 / 115	195 / 115
	Temperature rise range (F)	–	50 – 80	40 – 80	35 – 80
Low NO_x Gas Heat					
LOW	# of stages / # of burners (total)	1 / 2	1 / 2	1 / 2	–
	Connection size	1/2" NPT	1/2" NPT	1/2" NPT	–
	Rollout switch opens / closes	195 / 115	195 / 115	195 / 115	–
	Temperature rise range (F)	20 – 50	20 – 50	15 – 50	–
MED	# of stages / # of burners (total)	1 / 3	1 / 3	1 / 3	–
	Connection size	1/2" NPT	1/2" NPT	1/2" NPT	–
	Rollout switch opens / closes	195 / 115	195 / 115	195 / 115	–
	Temperature rise range (F)	30 – 60	30 – 60	25 – 60	–
HIGH	# of stages / # of burners (total)	–	1 / 3	1 / 3	–
	Connection size	–	1/2" NPT	1/2" NPT	–
	Rollout switch opens / closes	–	195 / 115	195 / 115	–
	Temperature rise range (F)	–	40 – 70	35 – 70	–

48TC

TABLE 10 – PHYSICAL DATA

(COOLING)

7.5 - 12.5 TONS

		48TC*A08	48TC*D08	48TC*A09	48TC*A12	48TC*D12	48TC*D14
Refrigeration System							
# Circuits / # Comp. / Type		1 / 1 / Scroll	2 / 2 / Scroll	1 / 1 / Scroll	1 / 1 / Scroll	2 / 2 / Scroll	2 / 2 / Scroll
Puron® refrig. (R-410A) charge per circuit A/B (lbs-oz)		13-12 / -	4-6 / 4-6	15-4 / -	20-0 / -	6-0 / 6-0	7-6 / 8-0
Oil A/B (oz)		60	42 / 42	85	110	42 / 42	56 / 56
Metering Device		Acutrol	Acutrol	Acutrol	Acutrol	Acutrol	Acutrol
High-press. Trip / Reset (psig)		630 / 505	630 / 505	630 / 505	630 / 505	630 / 505	630 / 505
Low-press. Trip / Reset (psig)		54 / 117	54 / 117	54 / 117	54 / 117	54 / 117	54 / 117
Evap. Coil							
Material		Cu / Al	Cu / Al	Cu / Al	Cu / Al	Cu / Al	Cu / Al
Coil type		3/8" RTPF	3/8" RTPF	3/8" RTPF	3/8" RTPF	3/8" RTPF	3/8" RTPF
Rows / FPI		3 / 15	3 / 15	3 / 15	4 / 15	4 / 15	4 / 15
Total Face Area (ft ²)		8.9	8.9	11.1	11.1	11.1	11.1
Condensate Drain Conn. Size		3/4"	3/4"	3/4"	3/4"	3/4"	3/4"
Evap. Fan and Motor							
Standard Static 3 phase	Motor Qty / Drive Type	1 / Belt	1 / Belt	1 / Belt	1 / Belt	1 / Belt	1 / Belt
	Max BHP	1.7	1.7	1.7	2.4	2.4	2.9*
	RPM Range	489-747	489-747	518-733	591-838	591-838	652-843
	Motor Frame Size	56	56	56	56	56	56
	Fan Qty / Type	1 / Centrifugal	1 / Centrifugal	1 / Centrifugal	1 / Centrifugal	1 / Centrifugal	1 / Centrifugal
	Fan Diameter (in)	15 x 15	15 x 15	15 x 15	15 x 15	15 x 15	15 x 15
Medium Static 3 phase	Motor Qty / Drive Type	1 / Belt	1 / Belt	1 / Belt	1 / Belt	1 / Belt	1 / Belt
	Max BHP	2.9*	2.9*	2.4	3.7	3.7	3.7
	RPM Range	733-949	733-949	690-936	838-1084	838-1084	838-1084
	Motor Frame Size	56	56	56	56	56	56
	Fan Qty / Type	1 / Centrifugal	1 / Centrifugal	1 / Centrifugal	1 / Centrifugal	1 / Centrifugal	1 / Centrifugal
	Fan Diameter (in)	15 x 15	15 x 15	15 x 15	15 x 15	15 x 15	15 x 15
High Static 3 phase	Motor Qty / Drive Type	1 / Belt	1 / Belt	1 / Belt	1 / Belt	1 / Belt	1 / Belt
	Max BHP	4.7	4.7	3.7	4.7	4.7	4.7
	RPM Range	909-1102	909-1102	838-1084	1022-1240	1022-1240	1022-1240
	Motor Frame Size	145TY	145TY	56	145TY	145TY	145TY
	Fan Qty / Type	1 / Centrifugal	1 / Centrifugal	1 / Centrifugal	1 / Centrifugal	1 / Centrifugal	1 / Centrifugal
	Fan Diameter (in)	15 x 15	15 x 15	15 x 15	15 x 15	15 x 15	15 x 15
Cond. Coil							
Material		Cu / Al	Al / Al	Cu / Al	Cu / Al	Al / Al	Al / Al
Coil type		3/8" RTPF	NOVATION™	3/8" RTPF	3/8" RTPF	NOVATION™	NOVATION™
Rows / FPI		2 / 17	1 / 20	2 / 17	2 / 17	1 / 20	2 / 20
Total Face Area (ft ²)		20.5	20.5	21.4	25.1	25.1	25.1
Cond. fan / motor							
Qty / Motor Drive Type		2 / Direct	2 / direct	2 / Direct	2 / Direct	2 / direct	1 / direct
Motor HP / RPM		1/4 / 1100	1/4 / 1100	1/4 / 1100	1/4 / 1100	1/4 / 1100	1 / 1175
Fan Diameter (in)		22	22	22	22	22	30
Filters							
RA Filter # / Size (in)		4 / 16 x 20 x 2	4 / 16 x 20 x 2	4 / 20 x 20 x 2	4 / 20 x 20 x 2	4 / 20 x 20 x 2	4 / 20 x 20 x 2
OA inlet screen # / Size (in)		1 / 20 x 24 x 1	1 / 20 x 24 x 1	1 / 20 x 24 x 1	1 / 20 x 24 x 1	1 / 20 x 24 x 1	1 / 20 x 24 x 1

48TC

* 575V motor utilizes 3.7 BHP.

TABLE 11 – PHYSICAL DATA

(HEATING)

7.5 - 12.5 TONS

		48TC**08	48TC**09	48TC**12	48TC**14
Gas Connection					
	# of Gas Valves	1	1	1	1
	Nat. gas supply line press (in. w.g.)/(PSIG)	4 – 13 / 0.18 – 0.47	4 – 13 / 0.18 – 0.47	4 – 13 / 0.18 – 0.47	4 – 13 / 0.18 – 0.47
	Propane supply line press (in. w.g.)/(PSIG)	11 – 13 / 0.40 – 0.47	11 – 13 / 0.40 – 0.47	11 – 13 / 0.40 – 0.47	11 – 13 / 0.40 – 0.47
Heat Anticipator Setting (Amps)					
	1st stage	0.14	0.14	0.14	0.14
	2nd stage	0.14	0.14	0.14	0.14
Natural Gas, Propane Heat					
LOW	# of stages / # of burners (total)	1 / 3	1 / 3	2 / 4	2 / 4
	Connection size	1/2" NPT	1/2" NPT	3/4" NPT	3/4" NPT
	Rollout switch opens / closes	195 / 115	195 / 115	195 / 115	195 / 115
	Temperature rise range (F)	20 – 50	20 – 50	25 – 65	25 – 65
MED	# of stages / # of burners (total)	2 / 4	2 / 4	2 / 5	2 / 5
	Connection size	3/4" NPT	3/4" NPT	3/4" NPT	3/4" NPT
	Rollout switch opens / closes	195 / 115	195 / 115	195 / 115	195 / 115
	Temperature rise range (F)	35 – 65	30 – 65	30 – 65	25 – 65
HIGH	# of stages / # of burners (total)	2 / 5	2 / 5	2 / 5	2 / 5
	Connection size	3/4" NPT	3/4" NPT	3/4" NPT	3/4" NPT
	Rollout switch opens / closes	195 / 115	195 / 115	195 / 115	195 / 115
	Temperature rise range (F)	45 – 75	40 – 75	35 – 70	35 – 70

48TC

CURBS & WEIGHTS DIMENSIONS - CHASSIS 1

NOTES:

1. DIMENSIONS ARE IN INCHES, DIMENSIONS IN () ARE IN MILLIMETERS.
2. CENTER OF GRAVITY
3. DIRECTION OF AIR FLOW

48TC

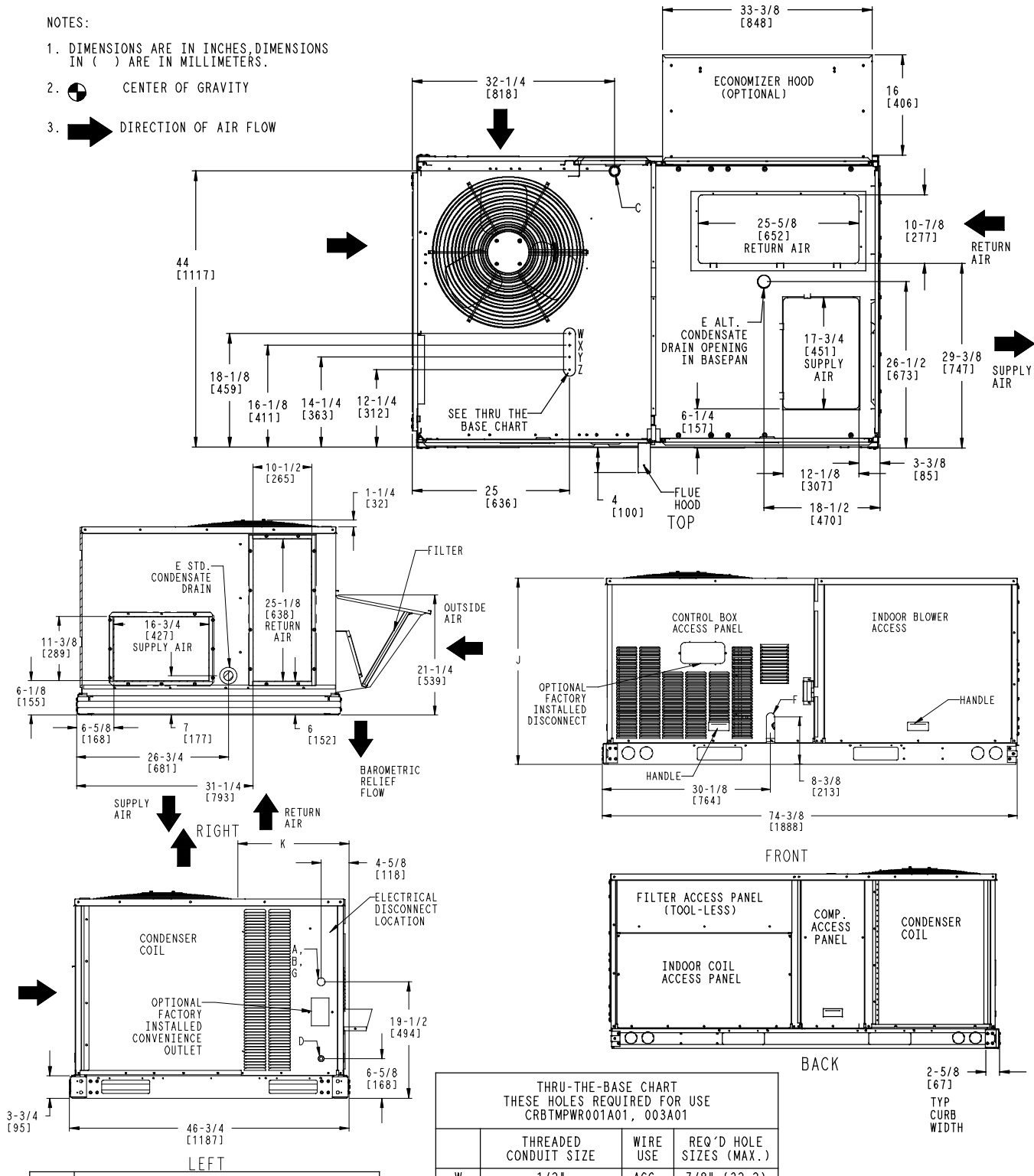

CONNECTION SIZES	
A	1 3/8" DIA [35] FIELD POWER SUPPLY HOLE
B	2" [50] DIA POWER SUPPLY KNOCKOUT
C	1 3/4" DIA [51] GAUGE ACCESS PLUG
D	7/8" DIA [22] FIELD CONTROL WIRING HOLE
E	3/4"-14 NPT CONDENSATE DRAIN
F	1/2"-14 NPT GAS CONNECTION
G	2 1/2" DIA [64] POWER SUPPLY KNOCK-OUT

THRU-THE-BASE CHART THESE HOLES REQUIRED FOR USE CRBTMPWR001A01, 003A01			
	THREADED CONDUIT SIZE	WIRE USE	REQ'D HOLE SIZES (MAX.)
W	1/2"	ACC.	7/8" (22.2)
X	1/2"	24V	7/8" (22.2)
Y *	3/4" (001,003)	POWER	1 1/8" (28.4)
Z**	(003) 1/2" FPT	GAS	1 3/16" (30.0)
FOR "THRU-THE-BASEPAN" FACTORY OPTION, FITTINGS FOR ONLY X, Y, & Z ARE PROVIDED			
*	SELECT EITHER 3/4" OR 1/2" FOR POWER, DEPENDING ON WIRE SIZE		
**	(001) PROVIDES 3/4" FPT THRU CURB FLANGE & FITTING.		

UNIT	J	K
48TC-A04	33 3/8 [847]	18 5/8 [472]
48TC-A05	33 3/8 [847]	14 7/8 [377]
48TC-A06	33 3/8 [847]	14 7/8 [377]
48TC-A07	41 3/8 [1051]	14 7/8 [377]

Fig. 1 - Dimensions 48TC 04-07

CURBS & WEIGHTS DIMENSIONS - CHASSIS 1 (cont.)

UNIT	STD. UNIT WEIGHT		CORNER WEIGHT (A)		CORNER WEIGHT (B)		CORNER WEIGHT (C)		CORNER WEIGHT (D)		C.G.		HEIGHT
	LBS.	KG.	LBS.	KG.	LBS.	KG.	LBS.	KG.	LBS.	KG.	X	Y	Z
48TC-A04	483	219	111	50	125	57	131	59	116	53	39 [991]	23 [584]	16 3/8 [416]
48TC-A05	537	244	124	56	139	63	145	66	129	59	39 [991]	23 [584]	17 [432]
48TC-A06	569	258	131	59	147	67	154	70	137	62	39 [991]	23 [584]	17 1/4 [438]
48TC-A07	652	296	150	68	169	76	176	80	157	71	39 [991]	23 [584]	20 1/8 [511]

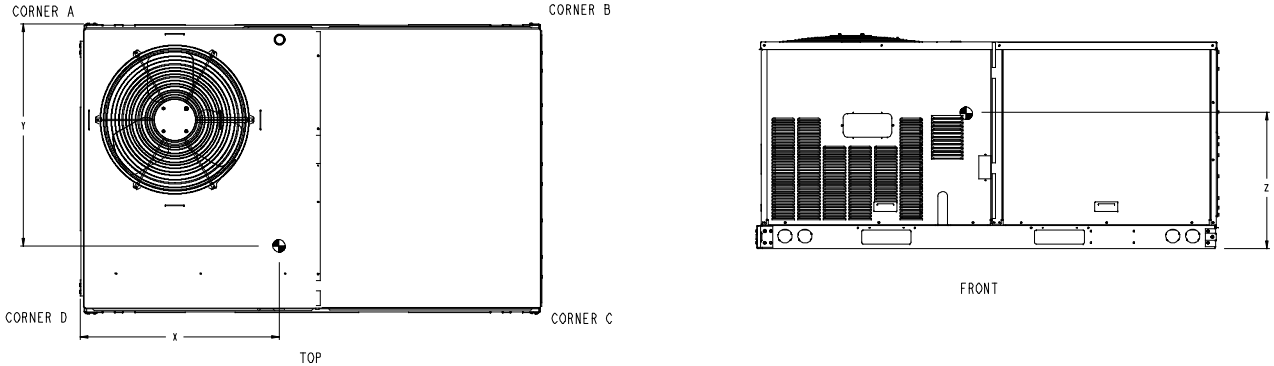

Fig. 2 - Dimensions 48TC 04-07

C08593

48TC

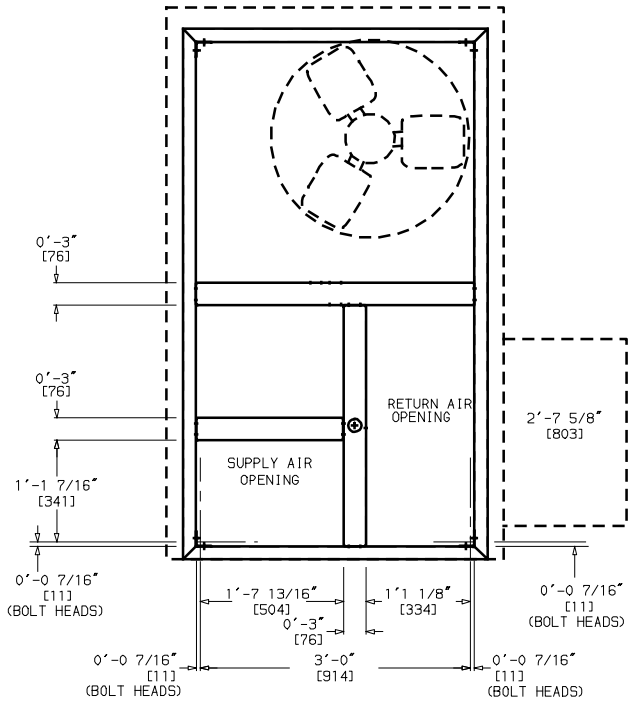

Fig. 3 - Curb Dimensions

C07458

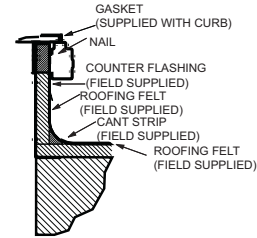

Fig. 4 - Curb Installation Detail (Typical)

C07457

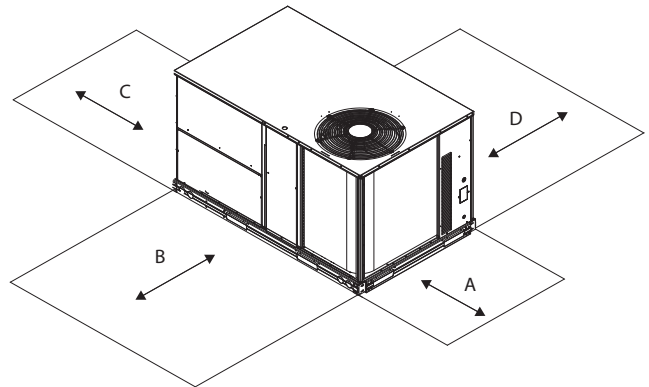

Fig. 5 - Service Clearance

C08337

LOC	DIMENSION	CONDITION
A	48" (1219 mm)	Unit disconnect is mounted on panel
	18" (457 mm)	No disconnect, convenience outlet option
	18" (457 mm)	Recommended service clearance
	12" (305 mm)	Minimum clearance
B	42" (1067 mm)	Surface behind servicer is grounded (e.g., metal, masonry wall)
	36" (914 mm) Special	Surface behind servicer is electrically non-conductive (e.g., wood, fiberglass) Check for sources of flue products within 10-ft of unit fresh air intake hood
C	36" (914 mm)	Side condensate drain is used
	18" (457 mm)	Minimum clearance
D	48" (1219 mm)	No flue discharge accessory installed, surface is combustible material
	42" (1067 mm)	Surface behind servicer is grounded (e.g., metal, masonry wall, another unit)
	36" (914 mm)	Surface behind servicer is electrically non-conductive (e.g., wood, fiberglass)
	Special	Check for adjacent units or building fresh air intakes within 10-ft of this unit's flue outlet

CURBS & WEIGHTS DIMENSIONS - CHASSIS 2

NOTES:

1. DIMENSIONS ARE IN INCHES, DIMENSIONS IN () ARE IN MILLIMETERS.
2. CENTER OF GRAVITY
3. DIRECTION OF AIR FLOW

48TC

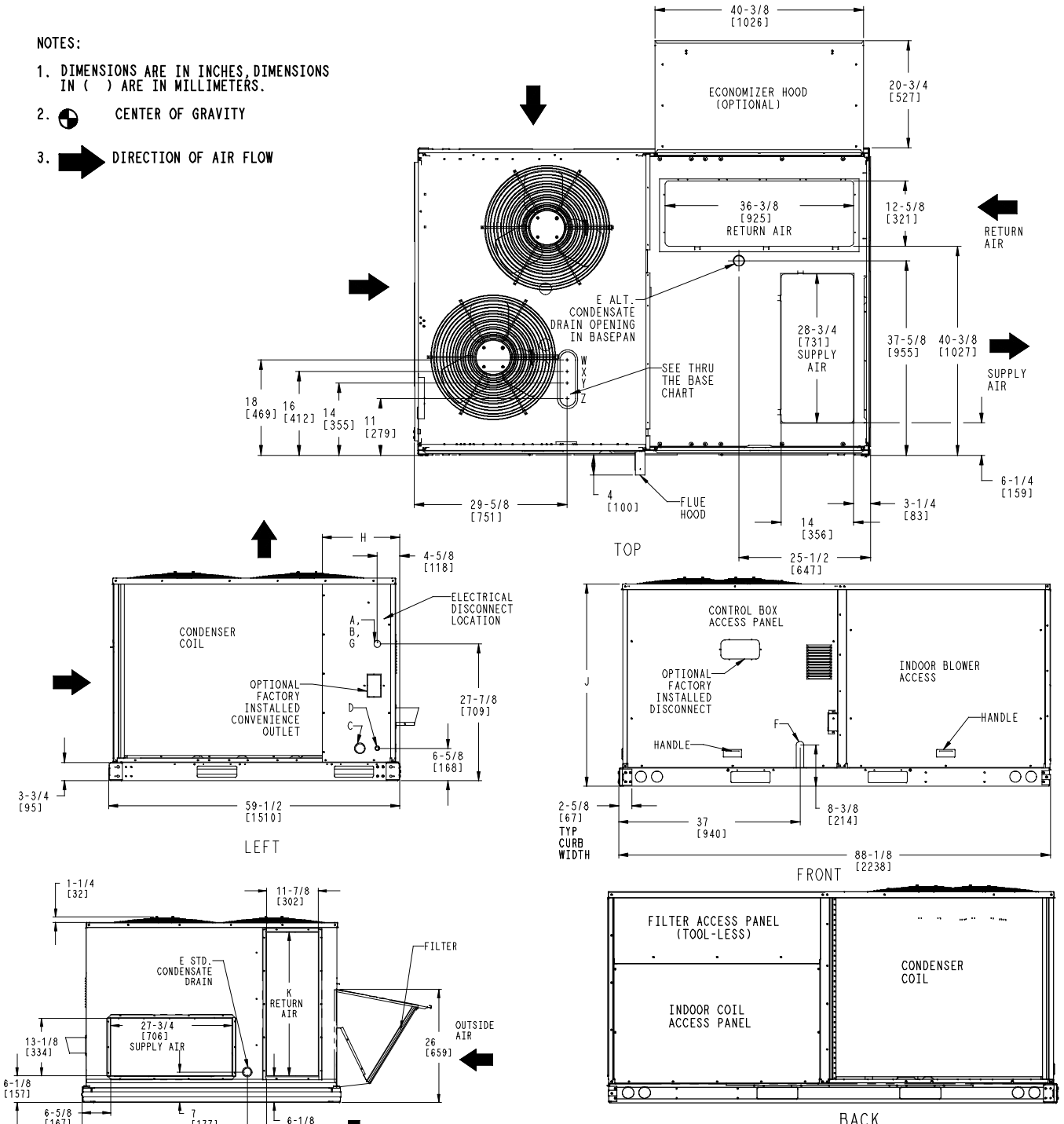

CONNECTION SIZES	
A	1 3/8" DIA [35] FIELD POWER SUPPLY HOLE
B	2 1/2" [64] DIA POWER SUPPLY KNOCKOUT
C	1 3/4" DIA [51] GAUGE ACCESS PLUG
D	7/8" DIA [22] FIELD CONTROL WIRING HOLE
E	3/4"-14 NPT CONDENSATE DRAIN
F	1/2"-14 NPT GAS CONNECTION 3/4"-14 NPT GAS CONNECTION
G	2" DIA [51] POWER SUPPLY KNOCK-OUT

THRU-THE-BASE CHART THESE HOLES REQUIRED FOR USE CRBTMPNR002A01, 004A01			
	THREADED CONDUIT SIZE	WIRE USE	REQ'D HOLE SIZES (MAX.)
W	1/2"	ACC.	7/8" (22.2)
X	1/2"	24V	7/8" (22.2)
Y	1 1/4" (002,004)	POWER	1 3/4" (44.4)
Z **,*	(004) 3/4" FPT	GAS	1 5/8" (41.3)
FOR "THRU-THE-BASEPAN" FACTORY OPTION, FITTINGS FOR ONLY X, Y, & Z ARE PROVIDED			
*	FOR HEAT SIZES "D" & "S" - A FIELD SUPPLIED 1/2" ADAPTER IS REQUIRED BETWEEN BASE PAN FITTING AND GAS VALVE.		
**	(002) PROVIDES 3/4" FPT THRU CURB FLANGE & FITTING.		

UNIT	J	K	H
48TC-A08	41 1/4 [1048]	33 [658]	15 7/8 [403]
48TC-A09	49 3/8 [1253]	37 1/4 [946]	23 7/8 [609]
48TC-A12	49 3/8 [1253]	37 1/4 [946]	15 7/8 [403]
48TC-D08	41 1/4 [1048]	33 [658]	15 7/8 [403]
48TC-D12	49 3/8 [1253]	37 1/4 [946]	15 7/8 [403]

* - FOR TWO STAGE COOLING MODELS WITH NOVATION CONDENSER COILS.

Fig. 6 - Dimensions 48TC 08-12

CURBS & WEIGHTS DIMENSIONS - CHASSIS 2 (cont.)

UNIT	STD. UNIT WEIGHT		CORNER WEIGHT (A)		CORNER WEIGHT (B)		CORNER WEIGHT (C)		CORNER WEIGHT (D)		C.G.		
	LBS.	KG.	LBS.	KG.	LBS.	KG.	LBS.	KG.	LBS.	KG.	X	Y	Z
48TC-A08	810	367	171	78	164	74	233	106	242	110	41 7/8 (1064)	33 7/8 (860)	20 1/4 (514)
48TC-A09	910	413	193	88	181	82	260	118	276	125	41 3/8 (1051)	22 7/8 (581)	22 7/8 (581)
48TC-A12	965	438	207	94	204	93	275	125	279	127	42 3/8 (1076)	24 1/8 (613)	24 1/8 (613)
48TC-D08	860	390	153	69.3	147	66.6	273	124	284	129	42 3/4 (1088)	37 1/2 (954)	20 1/8 (512)
48TC-D12	940	426	196	88.9	190	86.2	271	123	279	127	42 (1067)	33 7/8 (862)	20 1/4 (513)

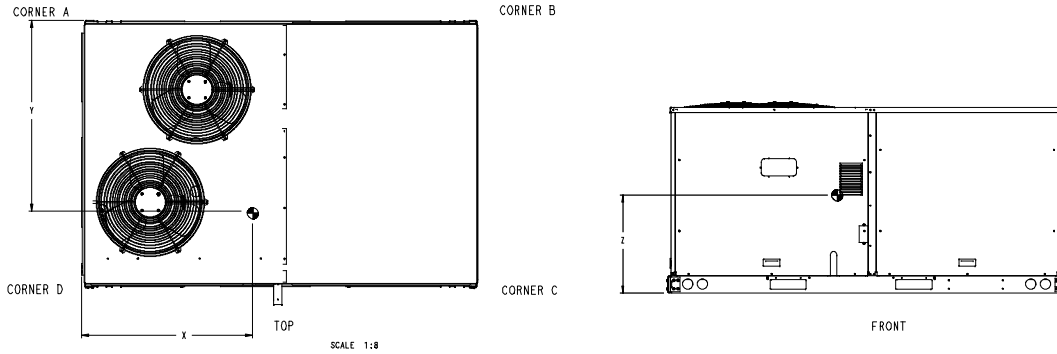

Fig. 7 - 48TC 08-12

C08520

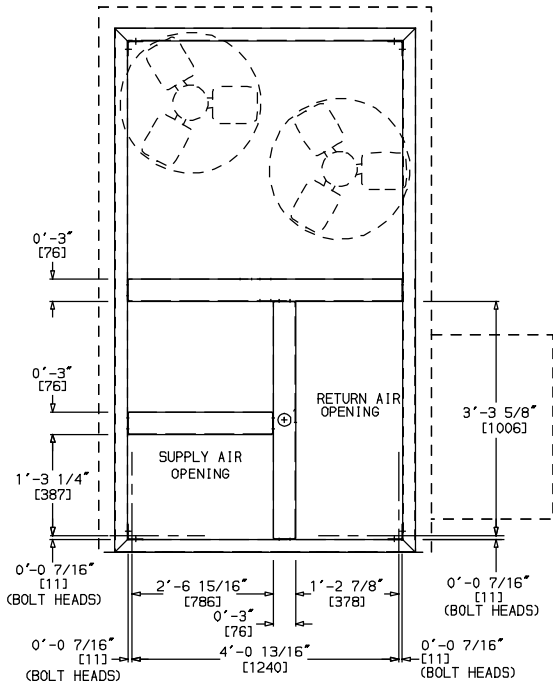

Fig. 8 - Curb Dimensions

C08309

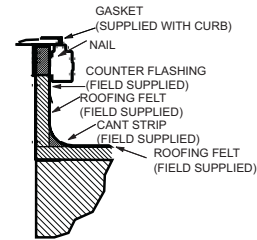

Fig. 9 - Curb Installation Detail (Typical)

C07457

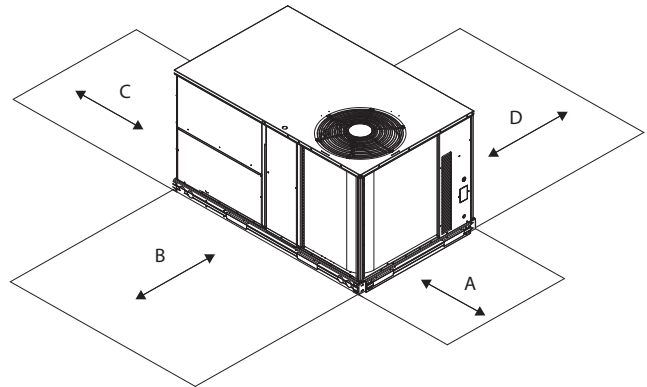

Fig. 10 - Service Clearance

C08337

LOC	DIMENSION	CONDITION
A	48" (1219 mm)	Unit disconnect is mounted on panel
	36" (914 mm)	If dimension-B is 12" (305 mm)
	18" (457 mm)	No disconnect, convenience outlet option
	18" (457 mm)	Recommended service clearance (use electric screwdriver)
	12" (305 mm)	Minimum clearance (use manual ratchet screwdriver)
B	36" (914 mm)	Unit has economizer
	12" (305 mm) Special	If dimension-A is 36" (914 mm) Check for sources of flue products within 10-ft of unit fresh air intake hood
C	36" (914 mm)	Side condensate drain is used
	18" (457 mm)	Minimum clearance
D	48" (1219 mm)	No flue discharge accessory installed, surface is combustible material
	42" (1067 mm)	Surface behind servicer is grounded (e.g., metal, masonry wall, another unit)
	36" (914 mm)	Surface behind servicer is electrically non-conductive (e.g., wood, fiberglass)
	Special	Check for adjacent units or building fresh air intakes within 10-ft of this unit's flue outlet

48TC

CURBS & WEIGHTS DIMENSIONS - CHASSIS 3

NOTES:

1. DIMENSIONS ARE IN INCHES, DIMENSIONS IN () ARE IN MILLIMETERS.
2. CENTER OF GRAVITY
3. DIRECTION OF AIR FLOW

48TC

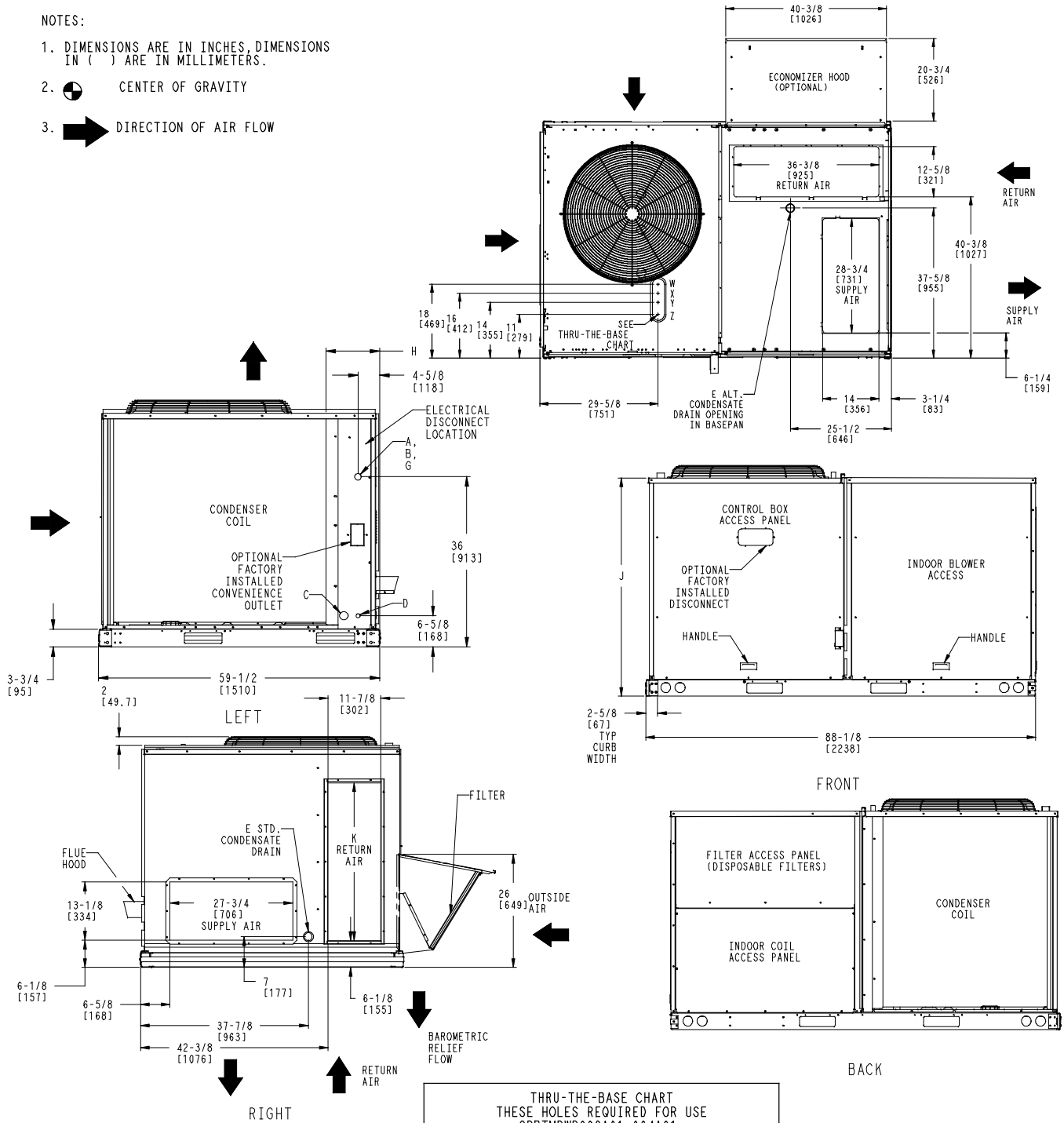

CONNECTION SIZES	
A	1 3/8" [35] DIA FIELD POWER SUPPLY HOLE
B	2 1/2" [64] DIA POWER SUPPLY KNOCKOUT
C	1 3/4" [51] DIA GAUGE ACCESS PLUG
D	7/8" [22] DIA FIELD CONTROL WIRING HOLE
E	3/4"-14 NPT CONDENSATE DRAIN
F	3/4"-14 NPT GAS CONNECTION
G	2" [51] DIA POWER SUPPLY KNOCK-OUT

THRU-THE-BASE CHART THESE HOLES REQUIRED FOR USE CRBTMPWR002A01, 004A01			
	THREADED CONDUIT SIZE	WIRE USE	REQ'D HOLE SIZES (MAX.)
W	1/2"	ACC.	7/8" (22.2)
X	1/2"	24V	7/8" (22.2)
Y	1 1/4" (002,004)	POWER	1 3/4" (44.4)
Z*	(004) 3/4" FPT	GAS	1 5/8" (41.3)
FOR "THRU-THE-BASEPAN" FACTORY OPTION, FITTINGS FOR ONLY X, Y, & Z ARE PROVIDED			
*	(002) PROVIDES 3/4" FPT THRU CURB FLANGE & FITTING.		

UNIT	H	J	K
48TC-D14	11 3/8 [289]	49 3/8 [1253]	35 5/8 [905]

Fig. 11 - Dimensions 48TC-14

C08521

CURBS & WEIGHTS DIMENSIONS - CHASSIS 3 (cont.)

UNIT	STD. UNIT WEIGHT		CORNER WEIGHT (A)		CORNER WEIGHT (B)		CORNER WEIGHT (C)		CORNER WEIGHT (D)		C.G.		
	LBS.	KG.	LBS.	KG.	LBS.	KG.	LBS.	KG.	LBS.	KG.	X	Y	Z
48TC-D14	1116	506	297	135	157	71	229	104	434	197	29 1/2 (749)	34 1/4 (870)	20 1/4 (514)

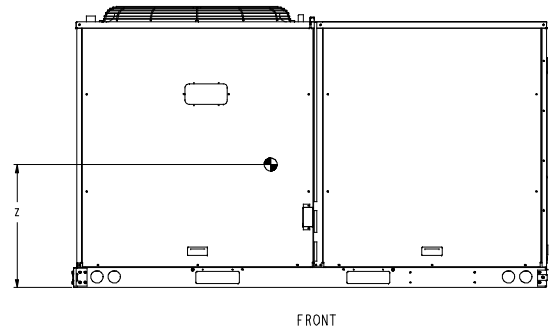
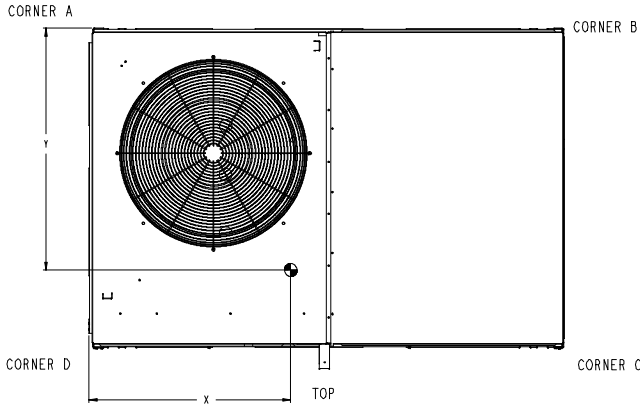

48TC

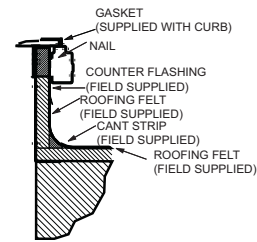
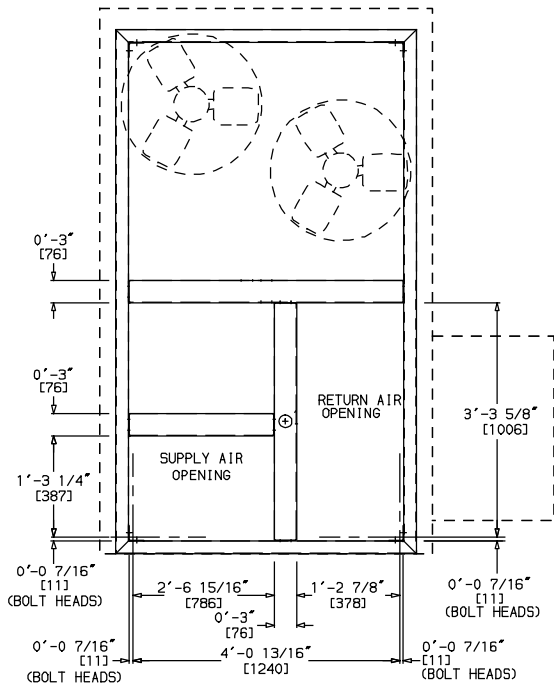

Fig. 13 - Curb Installation Detail (Typical)

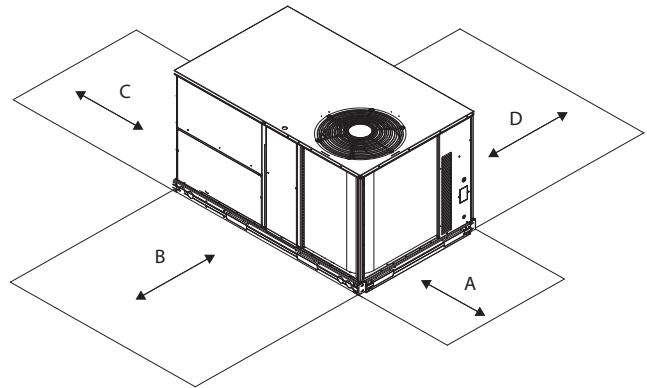

Fig. 12 - Curb Dimensions

Fig. 14 - Service Clearance

LOC	DIMENSION	CONDITION
A	48" (1219 mm)	Unit disconnect is mounted on panel
	36" (914 mm)	If dimension-B is 12" (305 mm)
	18" (457 mm)	No disconnect, convenience outlet option
	18" (457 mm)	Recommended service clearance (use electric screwdriver)
	12" (305 mm)	Minimum clearance (use manual ratchet screwdriver)
B	36" (914 mm)	Unit has economizer
	12" (305 mm) Special	If dimension-A is 36" (914 mm) Check for sources of flue products within 10-ft of unit fresh air intake hood
C	36" (914 mm)	Side condensate drain is used
	18" (457 mm)	Minimum clearance
D	48" (1219 mm)	No flue discharge accessory installed, surface is combustible material
	42" (1067 mm)	Surface behind servicer is grounded (e.g., metal, masonry wall, another unit)
	36" (914 mm) Special	Surface behind servicer is electrically non-conductive (e.g., wood, fiberglass) Check for adjacent units or building fresh air intakes within 10-ft of this unit's flue outlet

APPLICATION DATA

Min operating ambient temp (cooling):

In mechanical cooling mode, your Carrier rooftop unit can safely operate down to an outdoor ambient temperature of 40°F (4°C) and 25°F (-4°C), with an accessory winter start kit. It is possible to provide cooling at lower outdoor ambient temperatures by using less outside air, economizers, and/or accessory low ambient kits.

Max operating ambient temp (cooling):

The maximum operating ambient temperature for cooling mode is 115°F (46°C). While cooling operation above 115°F (46°C) may be possible, it could cause either a reduction in performance, reliability, or a protective action by the unit's internal safety devices.

Min mixed air temp (heating):

Using the factory settings, the minimum temperatures for the mixed air (the combined temperature of the warm return air and the cold outdoor air) entering the dimpled, gas heat exchangers are:

Aluminized

50°F (10°C) continuous

45°F (7°C) intermittent

Stainless Steel

40°F (4°C) continuous

35°F (2°C) intermittent

Operating at lower mixed-air temperatures may be possible, if a field-supplied, outdoor air thermostat initiates both heat stages when the temperature is less than the minimum temperatures listed above. Please contact your local Carrier representative for assistance.

Min and max airflow (heating and cooling):

To maintain safe and reliable operation of your rooftop, operate within the heating airflow limits during heating mode and cooling airflow limits during cooling mode. Operating above the max may cause blow-off, undesired airflow noise, or airflow related problems with the rooftop unit. Operating below the min may cause problems with coil freeze-up and unsafe heating operation. Heating and cooling limitations differ when evaluating operating CFM, the minimum value is the HIGHER of the cooling and heating minimum CFM values published in Table 7 and the maximum value is the LOWER of the cooling and heating minimum values published in Table 7.

Heating-to-cooling changeover:

Your unit will automatically change from heating to cooling mode when using a thermostat with an auto-change-over feature.

Airflow:

All units are draw-through in cooling mode and blow-through in heating mode.

Outdoor air application strategies:

Economizers reduce operating expenses and compressor run time by providing a free source of cooling and a means of ventilation to match application changing needs. In fact, they should be considered for most applications. Also, consider the various economizer control methods and their benefits, as well as sensors required to accomplish your application goals. Please contact your local Carrier representative for assistance.

Motor limits, break horsepower (BHP):

Due to internal design of Carrier units, the air path, and specially designed motors, the full horsepower (maximum continuous BHP) band, as listed in Table 8 and 10, can be used with the utmost confidence. There is no need for extra safety factors, as Carrier motors are designed and rigorously tested to use the entire, listed BHP range without either nuisance tripping or premature motor failure.

Propane heating:

Propane has different physical qualities than natural gas. As a result, Propane requires different fuel to air mixture. To optimize the fuel/air mixture for Propane, Carrier sells different burner orifices in an easy to install accessory kit. To select the correct burner orifices or determine the heat capacity for an Propane application, use either the selection software, or the unit's service manual.

High altitude heating:

High altitudes have less oxygen, which affects the fuel/air mixture in heat exchangers. In order to maintain a proper fuel/air mixture, heat exchangers operating in altitudes above 2000 ft (610 m) require different orifices. To select the correct burner orifices or determine the heat capacity for a high altitude application, use either the selection software, or the unit's service manual.

High altitudes have less oxygen, which means heat exchangers need less fuel. The new gas orifices in this field-installed kit make the necessary adjustment for high altitude applications. They restore the optimal fuel to air mixture and maintain healthy combustion on altitudes above 2000 ft (610 m).

NOTE: Typical natural gas heating value ranges from 975 to 1050 Btu/ft³ at sea level nationally. The heating value goes down approximately 1.7% per every thousand feet elevation. Standard factory orifices can typically be used up to 2000 ft (610m) elevation without any operational issues.

NOTE: For installations in Canada, the input rating should be derated by 10% for altitudes from 2000 ft (610m) to 4500 ft (1372m) above sea level.

Sizing a rooftop

Bigger isn't necessarily better. While an air conditioner needs to have enough capacity to meet the design loads, it doesn't need excess capacity. In fact, excess capacity typically results in very poor part load performance and humidity control.

Using higher design temperatures than ASHRAE recommends for your location, adding "safety factors" to the calculated load, are all signs of oversizing air conditioners. Oversizing the air conditioner leads to poor humidity control, reduced efficiency, higher utility bills, larger indoor temperature swings, excessive noise, and increased wear and tear on the air conditioner.

Rather than oversizing an air conditioner, engineers should "right-size" or even slightly undersize air conditioners. Correctly sizing an air conditioner controls humidity better; promotes efficiency; reduces utility bills; extends equipment life, and maintains even, comfortable temperatures. Please contact your local Carrier representative for assistance.

Low ambient applications

The optional Carrier economizer can adequately cool your space by bringing in fresh, cool outside air. In fact, when so equipped, accessory low-ambient kit may not be necessary. In low ambient conditions, unless the outdoor air is excessively humid or contaminated, economizer-based "free cooling" is the preferred less costly and energy conscious method.

In low ambient applications where outside air might not be desired (such as contaminated or excessively humid outdoor environments), your Carrier rooftop can operate to ambient temperatures down to -20° F (-29° C) using the recommended accessory Motormaster low ambient controller.

SELECTION PROCEDURE (WITH 48TC*A07 EXAMPLE)¹

I. Determine cooling and heating loads.

Given:

Mixed air dry bulb	80°F (27°C)
Mixed air wet bulb	67°F (19°C)
Ambient dry bulb	95°F (35°C)
TC _{Load}	72.0 MBH
SHC _{Load}	54.0 MBH
Vertical supply air	2100 CFM
Heating load	85.0 MBH
External static pressure	0.67 in. wg
Electrical characteristics	230-3-60

II. Make an initial guess at cooling tons.

Refrig. tons = TC_{Load} / 12 MBH per ton
 Refrig. tons = 72.0 / 12 = 6.0 tons
 In this case, start by looking at the 48TC*A07.

III. Look up the rooftop's TC and SHC.

Table 15 shows that, at the application's supply air CFM, mixed air and ambient temperatures, the 48TC*A07 supplies:
 TC = 73.7 MBH²
 SHC = 54.4 MBH²

IV. Calculate the building latent heat load.

LC_{Load} = TC_{Load} - SHC_{Load}
 LC_{Load} = 72.0 MBH - 54.0 MBH = 18.0 MBH

V. Calculate RTU latent heat capacity.

LC = TC - SHC
 LC = 73.7 MBH - 54.4 MBH = 19.3 MBH

VI. Compare RTU capacities to loads.³

Compare the rooftop's SHC and LC to the building's sensible and latent heat loads.

VII. Select factory options (FIOP)

Local code requires an economizer for any unit with TC greater than 65.0 MBH.

VIII. Calculate the total static pressure.

External static pressure	0.67 in. wg
Sum of FIOP / Accessory static	<u>+0.13 in. wg</u>
Total Static Pressure	0.80 in. wg

IX. Look up the indoor fan RPM & BHP.

Table 36 shows, at 2100 CFM & ESP= 0.8, RPM = 1358 & BHP = 1.52

X. Convert BHP (Step VIII) into fan motor heat.

Fan motor heat = 2.546* BHP/Motor Eff.⁴
 Fan motor heat = 4.9 MBH

XI. Calculate RTU heating capacity.

Building heating load	85.0 MBH
Fan motor heat	<u>-4.9 MBH</u>
Required heating capacity	80.1 MBH

XII. Select a gas heater.

Table 4 shows the heating capacities of the 48TCEA07 = 93.0 MBH. Select the 48TCEA07

XIII. Determine electrical requirements.

Table 56 shows the MCA and MOCP of a 48TC*A07 (without convenience outlet) as:
 MCA = 30.5 amps & MOCP = 45.0 amps
 Min. disconnect size: FLA = 30 & LRA = 157.

LEGEND

BHP	— Break horsepower
FLA	— Full load amps
LC	— Latent capacity
LRA	— Lock rotor amp
MBH	— (1,000) BTUH
MCA	— Min. circuit ampacity
MOCP	— Max. over-current protection
RPM	— Revolutions per minute
RTU	— Rooftop unit
SHC	— Sensible heat capacity
TC	— Total capacity

NOTES:

1. Selection software by Carrier saves time by performing many of the steps above. Contact your Carrier sales representative for assistance.
2. Unit ratings are gross capacities and do not include the effect of evaporator fan motor heat. See Step X. for determining amount of evaporator fan motor heat to subtract from total and sensible capacities to obtain net cooling and net sensible capacities.
3. Selecting a unit with a SHC slightly lower than the SHC_{Load} is often better than oversizing. Slightly lower SHC's will help control indoor humidity, and prevent temperature swings.
4. Indoor fan motor efficiency is available in Table 49. Use the decimal form in the equation, eg. 80% = .8.

TABLE 12 – COOLING CAPACITIES

1-STAGE COOLING

3 TONS

48TC*A04				AMBIENT TEMPERATURE											
				85			95			105			115		
				EAT (db)			EAT (db)			EAT (db)			EAT (db)		
				75	80	85	75	80	85	75	80	85	75	80	85
900 Cfm	EAT (wb)	58	TC	28.1	28.1	31.7	26.3	26.3	29.8	24.5	24.5	27.7	22.6	22.6	25.5
			SHC	24.4	28.1	31.7	22.9	26.3	29.8	21.3	24.5	27.7	19.6	22.6	25.5
		62	TC	30.3	30.3	31.0	27.8	27.8	29.8	25.1	25.1	28.4	22.6	22.6	26.5
			SHC	22.6	26.8	31.0	21.5	25.7	29.8	20.2	24.3	28.4	18.7	22.6	26.5
		67	TC	35.5	35.5	35.5	33.1	33.1	33.1	30.5	30.5	30.5	27.5	27.5	27.5
			SHC	19.5	23.7	27.9	18.5	22.7	26.9	17.4	21.6	25.8	16.2	20.4	24.6
		72	TC	39.0	39.0	39.0	37.1	37.1	37.1	35.1	35.1	35.1	32.7	32.7	32.7
			SHC	15.3	19.5	23.7	14.5	18.8	23.0	13.7	17.9	22.2	12.9	17.1	21.3
		76	TC	-	41.4	41.4	-	39.6	39.6	-	37.6	37.6	-	35.4	35.4
			SHC	-	16.0	21.0	-	15.4	20.2	-	14.6	19.3	-	13.8	18.3
1050 Cfm	EAT (wb)	58	TC	30.2	30.2	34.2	28.4	28.4	32.2	26.5	26.5	30.0	24.5	24.5	27.7
			SHC	26.3	30.2	34.2	24.7	28.4	32.2	23.1	26.5	30.0	21.3	24.5	27.7
		62	TC	31.9	31.9	34.2	29.4	29.4	32.8	26.7	26.7	31.2	24.5	24.5	28.8
			SHC	24.6	29.4	34.2	23.4	28.1	32.8	22.0	26.6	31.2	20.3	24.5	28.8
		67	TC	36.7	36.7	36.7	34.8	34.8	34.8	32.2	32.2	32.2	29.1	29.1	29.1
			SHC	20.6	25.4	30.2	19.8	24.6	29.4	18.8	23.6	28.4	17.6	22.4	27.2
		72	TC	40.1	40.1	40.1	38.2	38.2	38.2	36.1	36.1	36.1	33.7	33.7	33.7
			SHC	15.7	20.5	25.3	15.0	19.8	24.6	14.2	19.0	23.8	13.4	18.2	23.0
		76	TC	-	42.4	42.4	-	40.6	40.6	-	38.5	38.5	-	36.2	36.2
			SHC	-	16.6	22.2	-	15.9	21.3	-	15.2	20.4	-	14.4	19.5
1200 Cfm	EAT (wb)	58	TC	32.2	32.2	36.4	30.4	30.4	34.3	28.4	28.4	32.1	26.3	26.3	29.7
			SHC	28.0	32.2	36.4	26.4	30.4	34.3	24.7	28.4	32.1	22.8	26.3	29.7
		62	TC	33.3	33.3	37.0	30.8	30.8	35.5	28.4	28.4	33.4	26.3	26.3	30.9
			SHC	26.4	31.7	37.0	25.1	30.3	35.5	23.4	28.4	33.4	21.7	26.3	30.9
		67	TC	37.7	37.7	37.7	35.6	35.6	35.6	33.4	33.4	33.4	30.4	30.4	30.4
			SHC	21.7	27.0	32.4	20.9	26.3	31.6	20.0	25.4	30.8	18.8	24.2	29.6
		72	TC	40.9	40.9	40.9	39.0	39.0	39.0	36.9	36.9	36.9	34.4	34.4	34.4
			SHC	16.1	21.5	26.8	15.4	20.8	26.1	14.7	20.0	25.4	13.8	19.2	24.5
		76	TC	-	43.1	43.1	-	41.3	41.3	-	39.1	39.1	-	36.8	36.8
			SHC	-	17.1	23.1	-	16.4	22.3	-	15.7	21.4	-	14.9	20.5
1350 Cfm	EAT (wb)	58	TC	-	-	-	32.1	32.1	36.3	30.0	30.0	34.0	27.9	27.9	31.5
			SHC	-	-	-	27.9	32.1	36.3	26.1	30.0	34.0	24.2	27.9	31.5
		62	TC	28.4	28.4	30.5	32.2	32.2	37.8	30.1	30.1	35.3	27.9	27.9	32.8
			SHC	17.6	24.1	30.5	26.6	32.2	37.8	24.8	30.1	35.3	23.0	27.9	32.8
		67	TC	33.2	33.2	33.2	36.4	36.4	36.4	34.1	34.1	34.1	31.5	31.5	32.0
			SHC	15.0	21.4	27.9	21.9	27.8	33.7	21.0	26.9	32.9	20.0	26.0	32.0
		72	TC	37.5	37.5	37.5	39.7	39.7	39.7	37.5	37.5	37.5	35.0	35.0	35.0
			SHC	11.8	18.3	24.8	15.8	21.7	27.5	15.0	20.9	26.8	14.2	20.1	26.0
		76	TC	-	40.1	40.1	-	41.8	41.8	-	39.6	39.6	-	37.3	37.3
			SHC	-	15.3	22.7	-	16.8	23.2	-	16.1	22.3	-	15.3	21.5
1500 Cfm	EAT (wb)	58	TC	28.1	28.1	34.2	33.7	33.7	38.1	31.6	31.6	35.7	29.3	29.3	33.2
			SHC	21.9	28.1	34.2	29.3	33.7	38.1	27.4	31.6	35.7	25.5	29.3	33.2
		62	TC	30.3	30.3	33.8	33.7	33.7	39.6	31.6	31.6	37.1	29.4	29.4	34.5
			SHC	19.8	26.8	33.8	27.8	33.7	39.6	26.1	31.6	37.1	24.2	29.4	34.5
		67	TC	35.5	35.5	35.5	36.9	36.9	36.9	34.6	34.6	34.9	32.0	32.0	34.0
			SHC	16.7	23.7	30.7	22.8	29.2	35.7	21.9	28.4	34.9	21.0	27.5	34.0
		72	TC	39.0	39.0	39.0	40.2	40.2	40.2	38.0	38.0	38.0	35.5	35.5	35.5
			SHC	12.4	19.5	26.6	16.1	22.5	28.8	15.4	21.7	28.1	14.6	21.0	27.4
		76	TC	-	41.4	41.4	-	42.2	42.2	-	40.0	40.0	-	-	-
			SHC	-	16.0	24.3	-	17.2	24.0	-	16.5	23.2	-	-	-

48TC

LEGEND:

- Do not operate
- Cfm - Cubic feet per minute (supply air)
- EAT(db) - Entering air temperature (dry bulb)
- EAT(wb) - Entering air temperature (wet bulb)
- SHC - Sensible heat capacity
- TC - Total capacity

48TC04 (3 TONS) – UNIT WITH HUMIDI-MIZER SYSTEM IN HOT GAS REHEAT MODE

Air Entering Evaporator – CFM

Temp (F) Air Ent Condenser (Edb)		75 dry bulb			75 dry bulb			75 dry bulb		
		62.5 wet bulb (50% relative)			64 wet bulb (55% relative)			65.3 wet bulb (60% relative)		
		1050	1200	1350	1050	1200	1350	1050	1200	1350
80	TC	14.7	15.5	16.2	15.9	16.7	17.4	16.9	17.7	18.4
	SHC	6.7	7.6	8.5	4.8	5.7	6.6	3.2	4.1	5.0
	kW	2.0	2.0	2.0	2.0	2.0	2.0	2.0	2.0	2.0
75	TC	15.1	15.8	16.4	16.2	17.0	17.6	17.2	18.0	18.6
	SHC	7.5	8.4	9.2	5.8	6.7	7.5	4.4	5.2	6.0
	kW	1.9	1.9	1.9	2.0	2.0	2.0	2.0	2.0	2.0
70	TC	15.5	16.1	16.7	16.6	17.3	17.9	17.5	18.2	18.8
	SHC	8.4	9.3	10.0	6.9	7.7	8.5	5.5	6.4	7.1
	kW	1.9	1.9	1.9	1.9	1.9	1.9	1.9	1.9	1.9
60	TC	16.2	16.8	17.3	17.2	17.8	18.3	18.1	18.7	19.2
	SHC	10.2	10.9	11.6	8.9	9.7	10.4	7.8	8.6	9.3
	kW	1.8	1.8	1.8	1.8	1.8	1.8	1.9	1.9	1.9
50	TC	17.0	17.5	17.9	17.9	18.4	18.8	18.7	19.2	19.6
	SHC	11.9	12.6	13.2	11.0	11.6	12.2	10.1	10.8	11.4
	kW	1.7	1.7	1.7	1.8	1.8	1.8	1.8	1.8	1.8
40	TC	17.7	18.1	18.5	18.6	19.0	19.3	19.3	19.7	20.1
	SHC	13.7	14.3	14.8	13.0	13.6	14.1	12.4	13.0	13.5
	kW	1.7	1.7	1.7	1.7	1.7	1.7	1.7	1.7	1.7

48TC04 (3 TONS) – UNIT WITH HUMIDI-MIZER SYSTEM IN SUBCOOLING MODE

Air Entering Evaporator – CFM

Temp (F) Air Ent Condenser (Edb)		80 dry bulb			80 dry bulb			80 dry bulb		
		72 wet bulb			67 wet bulb			62 wet bulb		
		900	1200	1500	900	1200	1500	900	1200	1500
75	TC	40.6	43.2	45.3	37.0	39.4	41.3	33.4	35.6	37.4
	SHC	21.6	23.9	25.6	25.6	27.7	29.3	29.6	31.6	33.1
	kW	2.0	2.0	2.0	2.0	2.0	2.0	2.0	2.0	2.0
85	TC	37.0	39.6	41.7	33.6	36.0	37.9	30.2	32.3	34.1
	SHC	17.7	20.2	22.2	22.7	25.0	26.9	27.7	29.9	31.6
	kW	2.3	2.3	2.3	2.3	2.3	2.3	2.3	2.3	2.3
95	TC	33.5	36.0	38.1	30.2	32.5	34.4	26.9	29.1	30.8
	SHC	13.7	16.6	18.8	19.7	22.4	24.4	25.7	28.2	30.1
	kW	2.6	2.6	2.6	2.5	2.5	2.5	2.5	2.5	2.5
105	TC	29.9	32.4	34.5	26.8	29.1	31.0	23.6	25.8	27.5
	SHC	9.8	12.9	15.3	16.8	19.7	22.0	23.8	26.5	28.6
	kW	2.9	2.9	2.9	2.8	2.8	2.8	2.8	2.8	2.8
115	TC	26.3	28.8	30.9	23.3	25.7	27.5	20.4	22.5	24.2
	SHC	5.8	9.2	11.9	13.8	17.0	19.5	21.9	24.8	27.1
	kW	3.2	3.2	3.2	3.1	3.1	3.1	3.1	3.1	3.1
125	TC	22.8	25.3	27.3	19.9	22.2	24.1	17.1	19.2	20.8
	SHC	1.9	5.6	8.5	10.9	14.4	17.0	19.9	23.1	25.6
	kW	3.5	3.5	3.5	3.4	3.4	3.4	3.4	3.4	3.4

LEGEND

- Edb – Entering Dry–Bulb
- Ewb – Entering Wet–Bulb
- kW – Compressor Motor Power Input
- ldb – Leaving Dry–Bulb
- lwb – Leaving Wet–Bulb
- SHC – Sensible Heat Capacity (1000 Btuh) Gross
- TC – Total Capacity (1000 Btuh) Gross

NOTES:

1. Direct interpolation is permissible. Do not extrapolate.
2. The following formulas may be used:

$$t_{ldb} = t_{edb} - \frac{\text{sensible capacity (Btuh)}}{1.10 \times \text{cfm}}$$

t_{lwb} = Wet–bulb temperature corresponding to enthalpy of air leaving evaporator coil (h_{lwb})

$$h_{lwb} = h_{ewb} - \frac{\text{total capacity (Btuh)}}{4.5 \times \text{cfm}}$$

Where: h_{ewb} = Enthalpy of air entering evaporator coil

TABLE 13 – COOLING CAPACITIES

1-STAGE COOLING

4 TONS

48TC*A05			AMBIENT TEMPERATURE												
			85			95			105			115			
			EAT (db)			EAT (db)			EAT (db)			EAT (db)			
			75	80	85	75	80	85	75	80	85	75	80	85	
1200 Cfm	EAT (wb)	58	TC	-	-	-	-	-	-	36.1	36.1	40.7	34.3	34.3	38.6
		SHC	-	-	-	-	-	-	31.5	36.1	40.7	29.9	34.3	38.6	
		62	TC	43.1	43.1	43.1	40.8	40.8	40.8	38.4	38.4	39.4	35.9	35.9	38.2
		SHC	31.2	36.4	41.7	30.1	35.3	40.6	28.9	34.1	39.4	27.8	33.0	38.2	
		67	TC	47.4	47.4	47.4	45.2	45.2	45.2	42.9	42.9	42.9	40.3	40.3	40.3
		SHC	25.9	31.2	36.4	25.0	30.2	35.5	23.9	29.2	34.4	22.9	28.2	33.4	
		72	TC	51.1	51.1	51.1	49.1	49.1	49.1	46.8	46.8	46.8	43.9	43.9	43.9
		SHC	20.1	25.5	30.9	19.4	24.7	30.1	18.4	23.7	29.0	17.4	22.7	28.0	
		76	TC	-	53.3	53.3	-	51.5	51.5	-	49.2	49.2	-	45.9	45.9
		SHC	-	20.8	27.4	-	20.2	26.8	-	19.3	25.7	-	18.3	24.6	
1400 cfm	EAT (wb)	58	TC	41.9	41.9	47.3	40.1	40.1	45.3	38.2	38.2	43.2	36.3	36.3	41.0
		SHC	36.6	41.9	47.3	35.0	40.1	45.3	33.3	38.2	43.2	31.7	36.3	41.0	
		62	TC	44.6	44.6	45.4	42.3	42.3	44.2	39.8	39.8	42.9	37.3	37.3	41.6
		SHC	33.4	39.4	45.4	32.3	38.3	44.2	31.0	37.0	42.9	29.8	35.7	41.6	
		67	TC	48.7	48.7	48.7	46.6	46.6	46.6	44.2	44.2	44.2	41.4	41.4	41.4
		SHC	27.3	33.2	39.2	26.4	32.3	38.3	25.3	31.3	37.3	24.2	30.2	36.2	
		72	TC	52.2	52.2	52.2	50.3	50.3	50.3	47.8	47.8	47.8	44.8	44.8	44.8
		SHC	20.6	26.7	32.7	19.9	25.9	32.0	18.9	24.9	30.9	17.9	23.8	29.7	
		76	TC	-	54.1	54.1	-	52.3	52.3	-	49.9	49.9	-	46.4	46.4
		SHC	-	21.5	29.0	-	20.8	28.0	-	19.9	26.9	-	18.8	25.7	
1600 Cfm	EAT (wb)	58	TC	44.0	44.0	49.6	42.1	42.1	47.4	40.1	40.1	45.2	38.1	38.1	43.0
		SHC	38.3	44.0	49.6	36.7	42.1	47.4	34.9	40.1	45.2	33.2	38.1	43.0	
		62	TC	45.7	45.7	48.6	43.5	43.5	47.5	41.0	41.0	46.0	38.5	38.5	44.4
		SHC	35.3	42.0	48.6	34.2	40.8	47.5	32.9	39.4	46.0	31.6	38.0	44.4	
		67	TC	49.8	49.8	49.8	47.6	47.6	47.6	45.1	45.1	45.1	42.3	42.3	42.3
		SHC	28.4	35.0	41.6	27.6	34.2	40.9	26.5	33.2	39.9	25.4	32.1	38.7	
		72	TC	53.0	53.0	53.0	51.1	51.1	51.1	48.6	48.6	48.6	45.4	45.4	45.4
		SHC	21.0	27.6	34.3	20.3	27.0	33.6	19.4	26.0	32.6	18.3	24.8	31.3	
		76	TC	-	54.6	54.6	-	52.8	52.8	-	50.4	50.4	-	46.8	46.8
		SHC	-	22.0	29.9	-	21.3	29.0	-	20.3	27.9	-	19.2	26.6	
1800 Cfm	EAT (wb)	58	TC	44.0	44.0	50.3	42.1	42.1	48.1	40.1	40.1	45.9	38.0	38.0	43.5
		SHC	37.6	44.0	50.3	36.0	42.1	48.1	34.3	40.1	45.9	32.6	38.0	43.5	
		62	TC	45.7	45.7	49.5	43.5	43.5	48.3	41.0	41.0	46.8	38.4	38.4	45.2
		SHC	34.5	42.0	49.5	33.4	40.8	48.3	32.1	39.4	46.8	30.8	38.0	45.2	
		67	TC	49.8	49.8	49.8	47.6	47.6	47.6	45.1	45.1	45.1	42.3	42.3	42.3
		SHC	27.6	35.0	42.5	26.8	34.2	41.7	25.7	33.2	40.7	24.6	32.1	39.5	
		72	TC	53.0	53.0	53.0	51.1	51.1	51.1	48.6	48.6	48.6	45.4	45.4	45.4
		SHC	20.2	27.6	35.1	19.5	27.0	34.4	18.5	26.0	33.4	17.5	24.8	32.1	
		76	TC	-	54.6	54.6	-	52.8	52.8	-	50.4	50.4	-	46.8	46.8
		SHC	-	22.0	30.9	-	21.3	30.0	-	20.3	28.9	-	19.2	27.5	
2000 Cfm	EAT (wb)	58	TC	46.9	46.9	52.9	45.0	45.0	50.8	42.9	42.9	48.4	40.7	40.7	45.9
		SHC	40.9	46.9	52.9	39.3	45.0	50.8	37.4	42.9	48.4	35.5	40.7	45.9	
		62	TC	47.5	47.5	54.0	45.3	45.3	52.5	43.0	43.0	50.3	40.7	40.7	47.7
		SHC	38.5	46.3	54.0	37.3	44.9	52.5	35.6	43.0	50.3	33.8	40.7	47.7	
		67	TC	51.2	51.2	51.2	49.1	49.1	49.1	46.5	46.5	46.5	43.5	43.5	43.5
		SHC	30.5	38.3	46.0	29.8	37.6	45.5	28.7	36.6	44.5	27.5	35.4	43.2	
		72	TC	54.0	54.0	54.0	52.1	52.1	52.1	49.7	49.7	49.7	46.2	46.2	46.2
		SHC	21.7	29.2	36.8	21.1	28.7	36.4	20.1	27.8	35.4	18.9	26.4	33.9	
		76	TC	-	55.2	55.2	-	53.5	53.5	-	51.0	51.0	-	47.3	47.3
		SHC	-	22.7	31.4	-	22.0	30.6	-	21.1	29.6	-	19.9	28.1	

48TC

LEGEND:

- Do not operate
- Cfm - Cubic feet per minute (supply air)
- EAT(db) - Entering air temperature (dry bulb)
- EAT(wb) - Entering air temperature (wet bulb)
- SHC - Sensible heat capacity
- TC - Total capacity

48TC05 (4 TONS) – UNIT WITH HUMIDI-MIZER SYSTEM IN HOT GAS REHEAT MODE

Air Entering Evaporator – CFM

Temp (F) Air Ent Condenser (Edb)		75 dry bulb			75 dry bulb			75 dry bulb		
		62.5 wet bulb (50% relative)			64 wet bulb (55% relative)			65.3 wet bulb (60% relative)		
		1200	1600	2000	1200	1600	2000	1200	1600	2000
80	TC	11.6	13.8	15.5	13.5	15.8	17.6	15.2	17.5	19.3
	SHC	-1.0	1.2	3.0	-3.1	-0.8	0.9	-4.8	-2.6	-0.9
	kW	2.5	2.5	2.5	2.5	2.5	2.5	2.5	2.5	2.5
75	TC	12.5	14.6	16.2	14.3	16.4	18.1	15.9	18.1	19.8
	SHC	-0.7	1.4	3.0	-2.7	-0.6	1.1	-4.3	-2.2	-0.6
	kW	2.5	2.5	2.5	2.5	2.5	2.5	2.5	2.5	2.5
70	TC	13.4	15.3	16.8	15.1	17.1	18.7	16.6	18.7	20.3
	SHC	-0.5	1.5	3.0	-2.3	-0.3	1.2	-3.8	-1.9	-0.3
	kW	2.5	2.5	2.5	2.5	2.5	2.5	2.5	2.5	2.5
60	TC	15.1	16.8	18.1	16.7	18.4	19.8	18.1	19.9	21.2
	SHC	0.0	1.7	3.1	-1.5	0.2	1.5	-2.8	-1.1	0.2
	kW	2.6	2.6	2.6	2.6	2.6	2.6	2.6	2.6	2.6
50	TC	16.9	18.3	19.4	18.3	19.8	20.9	19.6	21.0	22.2
	SHC	0.6	2.0	3.1	-0.7	0.7	1.8	-1.8	-0.4	0.7
	kW	2.6	2.6	2.6	2.6	2.6	2.6	2.6	2.6	2.6
40	TC	18.7	19.8	20.7	19.9	21.1	22.0	21.0	22.2	23.2
	SHC	1.1	2.2	3.1	0.1	1.2	2.1	-0.8	0.4	1.3
	kW	2.6	2.6	2.6	2.7	2.7	2.7	2.7	2.7	2.7

48TC05 (4 TONS) – UNIT WITH HUMIDI-MIZER SYSTEM IN SUBCOOLING MODE

Air Entering Evaporator – CFM

Temp (F) Air Ent Condenser (Edb)		80 dry bulb			80 dry bulb			80 dry bulb		
		72 wet bulb			67 wet bulb			62 wet bulb		
		1200	1600	2000	1200	1600	2000	1200	1600	2000
75	TC	52.5	55.9	58.6	47.1	50.2	52.7	41.7	44.5	46.8
	SHC	22.6	25.5	27.8	27.1	29.9	32.0	31.6	34.2	36.2
	kW	2.5	2.5	2.5	2.5	2.5	2.5	2.5	2.5	2.5
85	TC	48.7	52.2	54.9	43.4	46.5	49.0	38.0	40.8	43.1
	SHC	18.0	21.3	23.9	23.6	26.8	29.2	29.3	32.2	34.4
	kW	2.9	2.9	2.9	2.9	2.9	2.9	2.9	2.9	2.9
95	TC	44.9	48.4	51.2	39.6	42.8	45.3	34.3	37.1	39.4
	SHC	13.4	17.2	20.0	20.2	23.7	26.4	27.0	30.2	32.7
	kW	3.4	3.4	3.4	3.3	3.3	3.3	3.3	3.3	3.3
105	TC	41.1	44.7	47.5	35.9	39.1	41.7	30.6	33.5	35.8
	SHC	8.8	13.0	16.1	16.7	20.6	23.6	24.6	28.2	31.0
	kW	3.8	3.8	3.8	3.7	3.7	3.7	3.7	3.7	3.7
115	TC	37.4	41.0	43.9	32.1	35.4	38.0	26.8	29.8	32.1
	SHC	4.3	8.8	12.2	13.3	17.5	20.7	22.3	26.2	29.2
	kW	4.2	4.2	4.2	4.2	4.2	4.2	4.1	4.1	4.1
125	TC	33.6	37.2	40.2	28.3	31.6	34.3	23.1	26.1	28.4
	SHC	-0.3	4.6	8.4	9.8	14.4	17.9	20.0	24.2	27.5
	kW	4.6	4.6	4.6	4.6	4.6	4.6	4.5	4.5	4.5

LEGEND

- Edb – Entering Dry–Bulb
- Ewb – Entering Wet–Bulb
- kW – Compressor Motor Power Input
- ldb – Leaving Dry–Bulb
- lwb – Leaving Wet–Bulb
- SHC – Sensible Heat Capacity (1000 Btuh) Gross
- TC – Total Capacity (1000 Btuh) Gross

NOTES:

1. Direct interpolation is permissible. Do not extrapolate.
2. The following formulas may be used:

$$t_{ldb} = t_{edb} - \frac{\text{sensible capacity (Btuh)}}{1.10 \times \text{cfm}}$$

t_{lwb} = Wet–bulb temperature corresponding to enthalpy of air leaving evaporator coil (h_{lwb})

$$h_{lwb} = h_{ewb} - \frac{\text{total capacity (Btuh)}}{4.5 \times \text{cfm}}$$

Where: h_{ewb} = Enthalpy of air entering evaporator coil

48TC

TABLE 14 – COOLING CAPACITIES

1-STAGE COOLING

5 TONS

48TC*A06			AMBIENT TEMPERATURE												
			85			95			105			115			
			EAT (db)			EAT (db)			EAT (db)			EAT (db)			
			75	80	85	75	80	85	75	80	85	75	80	85	
1500 Cfm	EAT (wb)	58	TC	52.9	52.9	60.0	49.9	49.9	56.6	46.6	46.6	52.9	43.1	43.1	48.9
		SHC	45.8	52.9	60.0	43.2	49.9	56.6	40.4	46.6	52.9	37.3	43.1	48.9	
		62	TC	56.2	56.2	57.6	52.2	52.2	55.7	47.8	47.8	53.5	43.2	43.2	51.0
		SHC	41.8	49.7	57.6	39.9	47.8	55.7	37.8	45.6	53.5	35.5	43.2	51.0	
		67	TC	62.4	62.4	62.4	58.8	58.8	58.8	54.4	54.4	54.4	49.5	49.5	49.5
		SHC	34.8	42.8	50.7	33.2	41.2	49.1	31.4	39.3	47.3	29.4	37.3	45.3	
		72	TC	68.2	68.2	68.2	64.8	64.8	64.8	60.8	60.8	60.8	56.2	56.2	56.2
		SHC	27.2	35.2	43.2	25.9	33.9	41.9	24.4	32.4	40.4	22.6	30.6	38.6	
		76	TC	-	71.1	71.1	-	69.0	69.0	-	65.4	65.4	-	60.9	60.9
		SHC	-	28.4	36.6	-	27.6	35.9	-	26.3	34.6	-	24.8	33.0	
1750 Cfm	EAT (wb)	58	TC	56.5	56.5	64.0	53.3	53.3	60.4	49.8	49.8	56.5	46.1	46.1	52.3
		SHC	48.9	56.5	64.0	46.1	53.3	60.4	43.1	49.8	56.5	39.9	46.1	52.3	
		62	TC	58.5	58.5	63.4	54.4	54.4	61.3	49.9	49.9	58.9	46.1	46.1	54.4
		SHC	45.2	54.3	63.4	43.2	52.2	61.3	41.0	49.9	58.9	37.9	46.1	54.4	
		67	TC	64.3	64.3	64.3	60.5	60.5	60.5	56.2	56.2	56.2	51.3	51.3	51.3
		SHC	36.9	46.1	55.2	35.3	44.5	53.7	33.6	42.8	51.9	31.6	40.8	49.9	
		72	TC	69.5	69.5	69.5	66.5	66.5	66.5	62.4	62.4	62.4	57.7	57.7	57.7
		SHC	27.8	36.9	45.9	26.7	35.9	45.1	25.2	34.5	43.7	23.5	32.8	42.0	
		76	TC	-	72.2	72.2	-	70.1	70.1	-	66.6	66.6	-	-	-
		SHC	-	29.3	38.9	-	28.6	38.2	-	27.4	36.8	-	-	-	
2000 Cfm	EAT (wb)	58	TC	59.3	59.3	67.3	56.1	56.1	63.6	52.5	52.5	59.5	48.6	48.6	55.1
		SHC	51.4	59.3	67.3	48.6	56.1	63.6	45.4	52.5	59.5	42.1	48.6	55.1	
		62	TC	60.1	60.1	68.5	56.2	56.2	66.3	52.5	52.5	62.0	48.7	48.7	57.4
		SHC	48.1	58.3	68.5	46.2	56.2	66.3	43.1	52.5	62.0	39.9	48.7	57.4	
		67	TC	65.7	65.7	65.7	61.9	61.9	61.9	57.5	57.5	57.5	52.6	52.6	54.4
		SHC	38.8	49.1	59.5	37.3	47.7	58.1	35.6	46.0	56.4	33.6	44.0	54.4	
		72	TC	70.1	70.1	70.1	67.6	67.6	67.6	63.6	63.6	63.6	58.9	58.9	58.9
		SHC	28.3	38.1	48.0	27.4	37.7	48.0	26.0	36.4	46.7	24.3	34.7	45.2	
		76	TC	-	72.9	72.9	-	70.8	70.8	-	67.4	67.4	-	-	-
		SHC	-	30.1	40.7	-	29.3	39.9	-	28.2	38.7	-	-	-	
2250 Cfm	EAT (wb)	58	TC	61.5	61.5	69.8	58.4	58.4	66.2	54.8	54.8	62.1	50.8	50.8	57.6
		SHC	53.2	61.5	69.8	50.5	58.4	66.2	47.4	54.8	62.1	43.9	50.8	57.6	
		62	TC	61.6	61.6	72.6	58.4	58.4	68.9	54.8	54.8	64.6	50.8	50.8	59.9
		SHC	50.6	61.6	72.6	47.9	58.4	68.9	45.0	54.8	64.6	41.7	50.8	59.9	
		67	TC	66.8	66.8	66.8	63.0	63.0	63.0	58.5	58.5	60.6	53.6	53.6	58.6
		SHC	40.5	52.0	63.4	39.1	50.7	62.3	37.4	49.0	60.6	35.5	47.0	58.6	
		72	TC	70.8	70.8	70.8	68.5	68.5	68.5	64.5	64.5	64.5	59.8	59.8	59.8
		SHC	28.7	39.5	50.2	28.0	39.3	50.5	26.7	38.1	49.6	25.0	36.6	48.1	
		76	TC	-	73.4	73.4	-	71.2	71.2	-	67.9	67.9	-	-	-
		SHC	-	30.7	42.1	-	30.0	41.4	-	28.9	40.4	-	-	-	
2500 Cfm	EAT (wb)	58	TC	63.3	63.3	71.8	60.1	60.1	68.2	56.5	56.5	64.1	52.6	52.6	59.6
		SHC	54.8	63.3	71.8	52.1	60.1	68.2	49.0	56.5	64.1	45.5	52.6	59.6	
		62	TC	63.4	63.4	74.7	60.2	60.2	71.0	56.6	56.6	66.7	52.6	52.6	62.1
		SHC	52.0	63.4	74.7	49.4	60.2	71.0	46.5	56.6	66.7	43.2	52.6	62.1	
		67	TC	67.6	67.6	67.6	63.8	63.8	66.2	59.3	59.3	64.6	54.4	54.4	62.5
		SHC	42.1	54.6	67.1	40.9	53.5	66.2	39.2	51.9	64.6	37.2	49.8	62.5	
		72	TC	71.3	71.3	71.3	69.0	69.0	69.0	65.1	65.1	65.1	60.4	60.4	60.4
		SHC	29.1	40.7	52.2	28.5	40.7	52.9	27.3	39.7	52.2	25.7	38.3	50.9	
		76	TC	-	73.8	73.8	-	71.4	71.4	-	68.3	68.3	-	-	-
		SHC	-	31.2	43.3	-	30.5	42.6	-	29.6	41.9	-	-	-	

48TC

LEGEND:

- Do not operate
- Cfm - Cubic feet per minute (supply air)
- EAT(db) - Entering air temperature (dry bulb)
- EAT(wb) - Entering air temperature (wet bulb)
- SHC - Sensible heat capacity
- TC - Total capacity

58TC06 (5 TONS) – UNIT WITH HUMIDI-MIZER SYSTEM IN HOT GAS REHEAT MODE

Air Entering Evaporator – CFM

Temp (F) Air Ent Condenser (Edb)		75 dry bulb			75 dry bulb			75 dry bulb		
		62.5 wet bulb (50% relative)			64 wet bulb (55% relative)			65.3 wet bulb (60% relative)		
		1750	2000	2250	1750	2000	2250	1750	2000	2250
80	TC	23.0	24.4	25.6	24.7	26.2	27.4	26.3	27.7	29.0
	SHC	5.3	6.1	6.8	3.2	4.0	4.7	1.4	2.2	2.9
	kW	2.9	2.9	2.9	2.9	2.9	2.9	2.9	2.9	2.9
75	TC	23.3	24.6	25.7	25.0	26.3	27.5	26.4	27.8	29.0
	SHC	5.1	5.8	6.5	3.1	3.9	4.5	1.4	2.2	2.8
	kW	2.9	2.9	2.9	2.9	2.9	2.9	2.9	2.9	2.9
70	TC	23.5	24.8	25.9	25.2	26.4	27.5	26.6	27.9	29.0
	SHC	4.8	5.5	6.2	3.0	3.7	4.3	1.4	2.1	2.8
	kW	3.0	3.0	3.0	3.0	3.0	3.0	3.0	3.0	3.0
60	TC	24.1	25.2	26.1	25.6	26.7	27.7	26.9	28.0	29.0
	SHC	4.3	5.0	5.5	2.8	3.4	3.9	1.4	2.0	2.6
	kW	3.0	3.0	3.0	3.0	3.0	3.0	3.0	3.0	3.0
50	TC	24.7	25.6	26.4	26.1	27.0	27.8	27.2	28.2	29.0
	SHC	3.8	4.4	4.8	2.5	3.1	3.5	1.4	2.0	2.4
	kW	3.1	3.1	3.1	3.1	3.1	3.1	3.1	3.1	3.1
40	TC	25.3	26.0	26.7	26.5	27.3	27.9	27.6	28.3	29.0
	SHC	3.3	3.8	4.2	2.3	2.8	3.1	1.4	1.9	2.3
	kW	3.1	3.1	3.1	3.2	3.2	3.2	3.2	3.2	3.2

48TC

58TC06 (5 TONS) – UNIT WITH HUMIDI-MIZER SYSTEM IN SUBCOOLING MODE

Air Entering Evaporator – CFM

Temp (F) Air Ent Condenser (Edb)		80 dry bulb			80 dry bulb			80 dry bulb		
		72 wet bulb			67 wet bulb			62 wet bulb		
		1750	2000	2250	1750	2000	2250	1750	2000	2250
75	TC	73.1	78.7	84.5	63.2	66.9	70.8	53.2	55.1	57.1
	SHC	35.3	37.2	38.8	42.0	43.7	45.3	48.7	50.3	51.8
	kW	3.3	3.3	3.3	3.3	3.3	3.3	3.3	3.3	3.3
85	TC	67.6	71.2	75.0	59.1	61.2	63.3	50.6	51.1	51.5
	SHC	27.9	30.0	31.9	36.3	38.3	40.1	44.8	46.6	48.2
	kW	3.8	3.8	3.8	3.8	3.8	3.8	3.8	3.8	3.8
95	TC	62.1	63.8	65.5	55.1	55.4	55.8	48.0	47.0	46.0
	SHC	20.5	22.9	24.9	30.7	32.9	34.8	40.9	42.9	44.7
	kW	4.3	4.3	4.3	4.3	4.3	4.3	4.3	4.3	4.3
105	TC	56.6	56.3	56.0	51.0	49.6	48.3	45.4	43.0	40.5
	SHC	13.1	15.7	18.0	25.0	27.5	29.6	36.9	39.2	41.2
	kW	4.8	4.8	4.8	4.8	4.8	4.8	4.7	4.7	4.7
115	TC	51.1	48.8	46.5	46.9	43.9	40.7	42.8	39.0	35.0
	SHC	5.8	8.6	11.0	19.4	22.0	24.4	33.0	35.5	37.7
	kW	5.3	5.3	5.3	5.3	5.3	5.3	5.2	5.2	5.2
125	TC	45.6	41.4	37.0	42.9	38.1	33.2	40.2	34.9	29.4
	SHC	-1.6	1.4	4.1	13.7	16.6	19.1	29.1	31.8	34.1
	kW	5.8	5.8	5.8	5.8	5.8	5.8	5.7	5.7	5.7

LEGEND

- Edb – Entering Dry–Bulb
- Ewb – Entering Wet–Bulb
- kW – Compressor Motor Power Input
- ldb – Leaving Dry–Bulb
- lwb – Leaving Wet–Bulb
- SHC – Sensible Heat Capacity (1000 Btuh) Gross
- TC – Total Capacity (1000 Btuh) Gross

NOTES:

1. Direct interpolation is permissible. Do not extrapolate.
2. The following formulas may be used:

$$t_{ldb} = t_{edb} - \frac{\text{sensible capacity (Btuh)}}{1.10 \times \text{cfm}}$$

t_{lwb} = Wet–bulb temperature corresponding to enthalpy of air leaving evaporator coil (h_{lwb})

$$h_{lwb} = h_{ewb} - \frac{\text{total capacity (Btuh)}}{4.5 \times \text{cfm}}$$

Where: h_{ewb} = Enthalpy of air entering evaporator coil

TABLE 15 – COOLING CAPACITIES

1-STAGE COOLING

6 TONS

48TC*A07			AMBIENT TEMPERATURE												
			85			95			105			115			
			EAT (db)			EAT (db)			EAT (db)			EAT (db)			
			75	80	85	75	80	85	75	80	85	75	80	85	
1800 Cfm	EAT (wb)	58	TC	64.9	64.9	73.3	62.1	62.1	70.0	58.9	58.9	66.4	55.6	55.6	62.7
		SHC	56.6	64.9	73.3	54.1	62.1	70.0	51.4	58.9	66.4	48.5	55.6	62.7	
		62	TC	68.7	68.7	70.3	64.9	64.9	68.5	60.8	60.8	66.4	56.4	56.4	64.0
		SHC	51.7	61.0	70.3	49.9	59.2	68.5	47.9	57.2	66.4	45.7	54.9	64.0	
		67	TC	75.6	75.6	75.6	71.7	71.7	71.7	67.4	67.4	67.4	62.5	62.5	62.5
	SHC	42.8	52.2	61.5	41.2	50.5	59.8	39.3	48.6	58.0	37.2	46.5	55.8		
	72	TC	82.6	82.6	82.6	78.5	78.5	78.5	73.7	73.7	73.7	67.8	67.8	67.8	
	SHC	33.5	42.8	52.2	31.9	41.3	50.6	30.0	39.3	48.6	27.8	36.9	45.9		
	76	TC	-	87.5	87.5	-	83.3	83.3	-	77.7	77.7	-	70.9	70.9	
	SHC	-	35.0	44.9	-	33.5	43.4	-	31.6	41.5	-	29.3	39.1		
2100 Cfm	EAT (wb)	58	TC	68.9	68.9	77.7	65.9	65.9	74.3	62.5	62.5	70.5	58.7	58.7	66.2
		SHC	60.1	68.9	77.7	57.4	65.9	74.3	54.5	62.5	70.5	51.2	58.7	66.2	
		62	TC	70.9	70.9	76.9	67.1	67.1	75.0	63.0	63.0	72.5	58.7	58.7	68.7
		SHC	55.6	66.3	76.9	53.8	64.4	75.0	51.6	62.1	72.5	48.7	58.7	68.7	
		67	TC	77.8	77.8	77.8	73.7	73.7	73.7	69.2	69.2	69.2	64.0	64.0	64.0
	SHC	45.4	56.1	66.8	43.7	54.4	65.2	41.8	52.5	63.2	39.6	50.2	60.7		
	72	TC	84.5	84.5	84.5	80.3	80.3	80.3	75.1	75.1	75.1	68.8	68.8	68.8	
	SHC	34.5	45.2	55.9	32.9	43.5	54.2	30.9	41.4	52.0	28.5	38.7	48.9		
	76	TC	-	89.2	89.2	-	84.7	84.7	-	78.8	78.8	-	71.6	71.6	
	SHC	-	36.3	47.8	-	34.7	46.0	-	32.6	43.7	-	30.1	40.9		
2400 Cfm	EAT (wb)	58	TC	72.0	72.0	81.2	68.7	68.7	77.5	65.2	65.2	73.5	61.1	61.1	68.9
		SHC	62.8	72.0	81.2	60.0	68.7	77.5	56.9	65.2	73.5	53.3	61.1	68.9	
		62	TC	72.8	72.8	82.8	68.9	68.9	80.7	65.2	65.2	76.4	61.2	61.2	71.6
		SHC	59.1	71.0	82.8	57.2	68.9	80.7	54.1	65.2	76.4	50.7	61.2	71.6	
		67	TC	79.4	79.4	79.4	75.2	75.2	75.2	70.5	70.5	70.5	65.1	65.1	65.3
	SHC	47.7	59.8	71.8	46.0	58.1	70.2	44.0	56.0	68.1	41.6	53.5	65.3		
	72	TC	86.0	86.0	86.0	81.6	81.6	81.6	76.1	76.1	76.1	69.6	69.6	69.6	
	SHC	35.3	47.2	59.2	33.7	45.6	57.5	31.7	43.3	55.0	29.1	40.3	51.4		
	76	TC	-	90.3	90.3	-	85.7	85.7	-	79.6	79.6	-	72.1	72.1	
	SHC	-	37.3	49.8	-	35.6	48.0	-	33.5	45.6	-	30.8	42.5		
2700 Cfm	EAT (wb)	58	TC	60.3	60.3	74.1	71.1	71.1	80.2	67.4	67.4	76.0	63.0	63.0	71.1
		SHC	46.4	60.3	74.1	62.0	71.1	80.2	58.8	67.4	76.0	55.0	63.0	71.1	
		62	TC	65.4	65.4	69.3	71.2	71.2	83.3	67.5	67.5	79.0	63.1	63.1	73.8
		SHC	41.0	55.1	69.3	59.0	71.2	83.3	55.9	67.5	79.0	52.3	63.1	73.8	
		67	TC	72.7	72.7	72.7	76.3	76.3	76.3	71.5	71.5	72.6	65.8	65.8	69.4
	SHC	33.8	48.0	62.2	48.2	61.6	74.9	46.1	59.3	72.6	43.5	56.5	69.4		
	72	TC	79.7	79.7	79.7	82.5	82.5	82.5	76.9	76.9	76.9	70.1	70.1	70.1	
	SHC	25.8	40.2	54.6	34.5	47.5	60.5	32.3	45.0	57.7	29.7	41.7	53.8		
	76	TC	-	85.1	85.1	-	86.4	86.4	-	80.2	80.2	-	72.5	72.5	
	SHC	-	33.5	48.4	-	36.5	49.9	-	34.3	47.3	-	31.5	44.0		
3000 Cfm	EAT (wb)	58	TC	64.9	64.9	78.8	73.1	73.1	82.5	69.2	69.2	78.0	64.5	64.5	72.7
		SHC	51.1	64.9	78.8	63.8	73.1	82.5	60.3	69.2	78.0	56.2	64.5	72.7	
		62	TC	68.7	68.7	76.5	73.2	73.2	85.7	69.2	69.2	81.0	64.5	64.5	75.5
		SHC	45.5	61.0	76.5	60.7	73.2	85.7	57.4	69.2	81.0	53.5	64.5	75.5	
		67	TC	75.6	75.6	75.6	77.2	77.2	79.4	72.2	72.2	76.8	66.3	66.3	73.0
	SHC	36.6	52.2	67.7	50.2	64.8	79.4	48.0	62.4	76.8	45.1	59.1	73.0		
	72	TC	82.6	82.6	82.6	83.3	83.3	83.3	77.5	77.5	77.5	70.5	70.5	70.5	
	SHC	27.2	42.8	58.5	35.1	49.2	63.3	32.9	46.6	60.3	30.2	43.0	55.9		
	76	TC	-	87.5	87.5	-	86.9	86.9	-	80.6	80.6	-	72.8	72.8	
	SHC	-	35.0	51.5	-	37.3	51.6	-	35.0	48.9	-	32.1	45.3		

48TC

LEGEND:

- Do not operate in this region
- Cfm - Cubic feet per minute (supply air)
- EAT(db) - Entering air temperature (dry bulb)
- EAT(wb) - Entering air temperature (wet bulb)
- SHC - Sensible heat capacity
- TC - Total capacity

48TC07 (6 TONS) – UNIT WITH HUMIDI-MIZER SYSTEM IN HOT GAS REHEAT MODE

Air Entering Evaporator – CFM

Temp (F) Air Ent Condenser (Edb)		75 dry bulb			75 dry bulb			75 dry bulb		
		62.5 wet bulb (50% relative)			64 wet bulb (55% relative)			65.3 wet bulb (60% relative)		
		2100	2400	2700	2100	2400	2700	1750	2000	2700
80	TC	16.7	19.8	22.5	18.8	21.9	24.7	16.2	19.4	26.7
	SHC	0.6	0.6	0.6	-0.4	-0.4	-0.4	-1.3	-1.3	-1.3
	kW	4.0	4.0	4.0	4.0	4.0	4.0	4.0	4.0	4.0
75	TC	17.7	20.6	23.1	19.6	22.6	25.3	17.3	20.3	27.1
	SHC	0.6	0.6	0.6	-0.3	-0.3	-0.3	-1.2	-1.2	-1.2
	kW	4.0	4.0	4.0	4.0	4.0	4.0	4.0	4.0	4.0
70	TC	18.6	21.3	23.7	20.5	23.3	25.8	18.3	21.1	27.6
	SHC	0.7	0.7	0.7	-0.2	-0.2	-0.2	-1.0	-1.0	-1.0
	kW	4.0	4.0	4.0	4.1	4.1	4.1	4.1	4.1	4.1
60	TC	20.5	22.9	25.0	22.2	24.7	26.8	20.4	22.8	28.5
	SHC	0.7	0.7	0.7	-0.0	-0.0	-0.0	-0.7	-0.7	-0.7
	kW	4.1	4.1	4.1	4.1	4.1	4.1	4.1	4.1	4.1
50	TC	22.4	24.4	26.2	24.0	26.0	27.9	22.4	24.5	29.3
	SHC	0.8	0.8	0.8	0.1	0.1	0.1	-0.4	-0.4	-0.4
	kW	4.1	4.1	4.1	4.1	4.1	4.1	4.2	4.2	4.2
40	TC	24.3	25.9	27.4	25.7	27.4	28.9	24.5	26.3	30.2
	SHC	0.8	0.8	0.8	0.3	0.3	0.3	-0.1	-0.1	-0.1
	kW	4.1	4.1	4.1	4.2	4.2	4.2	4.2	4.2	4.2

48TC07 (6 TONS) – UNIT WITH HUMIDI-MIZER SYSTEM IN SUBCOOLING MODE

Air Entering Evaporator – CFM

Temp (F) Air Ent Condenser (Edb)		80 dry bulb			80 dry bulb			80 dry bulb		
		72 wet bulb			67 wet bulb			62 wet bulb		
		2100	2400	2700	2100	2400	2700	2100	2400	2700
75	TC	86.7	89.9	92.8	79.3	82.3	84.9	71.9	74.6	77.0
	SHC	40.1	41.8	43.3	46.9	48.5	49.9	53.7	55.2	56.5
	kW	4.3	4.3	4.3	4.2	4.2	4.2	4.2	4.2	4.2
85	TC	79.5	82.6	85.4	72.5	75.3	77.9	65.4	68.0	70.3
	SHC	32.1	34.0	35.7	40.7	42.5	44.1	49.4	51.0	52.5
	kW	5.0	5.0	5.0	5.0	5.0	5.0	4.9	4.9	4.9
95	TC	72.4	75.3	78.1	65.6	68.3	70.8	58.8	61.3	63.6
	SHC	24.1	26.3	28.1	34.6	36.6	38.3	45.1	46.9	48.5
	kW	5.8	5.8	5.8	5.7	5.7	5.7	5.6	5.6	5.6
105	TC	65.2	68.1	70.7	58.7	61.4	63.8	52.3	54.7	56.8
	SHC	16.2	18.5	20.5	28.5	30.6	32.6	40.7	42.8	44.6
	kW	6.5	6.5	6.5	6.4	6.4	6.4	6.3	6.3	6.3
115	TC	58.0	60.8	63.3	51.9	54.4	56.7	45.7	48.0	50.1
	SHC	8.2	10.7	13.0	22.3	24.7	26.8	36.4	38.6	40.6
	kW	7.2	7.2	7.2	7.1	7.1	7.1	7.0	7.0	7.0
125	TC	50.8	53.5	55.9	45.0	47.4	49.6	39.2	41.4	43.4
	SHC	0.2	3.0	5.4	16.2	18.7	21.0	32.1	34.5	36.6
	kW	8.0	8.0	8.0	7.8	7.8	7.8	7.7	7.7	7.7

LEGEND

- Edb – Entering Dry–Bulb
- Ewb – Entering Wet–Bulb
- kW – Compressor Motor Power Input
- ldb – Leaving Dry–Bulb
- lwb – Leaving Wet–Bulb
- SHC – Sensible Heat Capacity (1000 Btuh) Gross
- TC – Total Capacity (1000 Btuh) Gross

NOTES:

1. Direct interpolation is permissible. Do not extrapolate.
2. The following formulas may be used:

$$t_{ldb} = t_{edb} - \frac{\text{sensible capacity (Btuh)}}{1.10 \times \text{cfm}}$$

t_{lwb} = Wet–bulb temperature corresponding to enthalpy of air leaving evaporator coil (h_{lwb})

$$h_{lwb} = h_{ewb} - \frac{\text{total capacity (Btuh)}}{4.5 \times \text{cfm}}$$

Where: h_{ewb} = Enthalpy of air entering evaporator coil

48TC

TABLE 16 – COOLING CAPACITIES

1-STAGE COOLING

7.5 TONS

48TC*A08			AMBIENT TEMPERATURE												
			85			95			105			115			
			EAT (db)			EAT (db)			EAT (db)			EA (db)			
			75	80	85	75	80	85	75	80	85	75	80	85	
2250 Cfm	EAT (wb)	58	TC	81.2	81.2	91.8	77.5	77.5	87.7	73.6	73.6	83.3	69.5	69.5	78.7
			SHC	70.5	81.2	91.8	67.3	77.5	87.7	63.9	73.6	83.3	60.4	69.5	78.7
		62	TC	86.9	86.9	86.9	82.3	82.3	84.0	77.2	77.2	81.5	71.9	71.9	78.8
			SHC	63.6	74.9	86.2	61.4	72.7	84.0	58.9	70.2	81.5	56.3	67.6	78.8
		67	TC	95.2	95.2	95.2	90.7	90.7	90.7	85.7	85.7	85.7	79.9	79.9	79.9
			SHC	52.8	64.2	75.6	50.9	62.2	73.6	48.8	60.1	71.5	46.3	57.6	68.9
		72	TC	103.5	103.5	103.5	98.9	98.9	98.9	93.8	93.8	93.8	87.3	87.3	87.3
			SHC	41.5	53.1	64.6	39.7	51.2	62.7	37.7	49.2	60.6	35.3	46.6	57.8
		76	TC	-	109.6	109.6	-	104.8	104.8	-	99.1	99.1	-	91.6	91.6
			SHC	-	43.7	56.0	-	42.0	54.3	-	40.0	52.4	-	37.4	49.8
2625 Cfm	EAT (wb)	58	TC	85.9	85.9	97.2	82.2	82.2	93.1	78.1	78.1	88.4	73.9	73.9	83.6
			SHC	74.6	85.9	97.2	71.4	82.2	93.1	67.9	78.1	88.4	64.1	73.9	83.6
		62	TC	89.6	89.6	94.1	85.1	85.1	91.7	80.1	80.1	89.1	74.6	74.6	86.0
			SHC	68.1	81.1	94.1	65.9	78.8	91.7	63.4	76.3	89.1	60.6	73.3	86.0
		67	TC	97.9	97.9	97.9	93.2	93.2	93.2	88.1	88.1	88.1	82.0	82.0	82.0
			SHC	55.7	68.7	81.7	53.7	66.7	79.8	51.6	64.6	77.6	49.0	62.0	74.9
		72	TC	106.0	106.0	106.0	101.3	101.3	101.3	95.9	95.9	95.9	89.0	89.0	89.0
			SHC	42.7	55.8	68.9	40.9	53.9	67.0	38.8	51.8	64.7	36.2	48.9	61.7
		76	TC	-	111.8	111.8	-	106.9	106.9	-	100.7	100.7	-	92.7	92.7
			SHC	-	45.3	59.8	-	43.6	58.0	-	41.4	55.6	-	38.7	52.6
3000 Cfm	EAT (wb)	58	TC	89.6	89.6	101.4	85.9	85.9	97.2	81.7	81.7	92.5	77.0	77.0	87.1
			SHC	77.9	89.6	101.4	74.6	85.9	97.2	71.0	81.7	92.5	66.9	77.0	87.1
		62	TC	91.8	91.8	101.1	87.2	87.2	98.6	82.3	82.3	95.5	77.1	77.1	90.6
			SHC	72.2	86.7	101.1	69.9	84.3	98.6	67.2	81.3	95.5	63.5	77.1	90.6
		67	TC	99.9	99.9	99.9	95.2	95.2	95.2	89.9	89.9	89.9	83.6	83.6	83.6
			SHC	58.3	72.9	87.5	56.4	71.0	85.5	54.2	68.8	83.4	51.6	66.1	80.5
		72	TC	107.9	107.9	107.9	103.0	103.0	103.0	97.3	97.3	97.3	90.1	90.1	90.1
			SHC	43.7	58.3	72.8	41.9	56.4	70.9	39.7	54.1	68.4	37.0	51.0	65.0
		76	TC	-	113.8	113.8	-	108.4	108.4	-	102.0	102.0	-	93.4	93.4
			SHC	-	46.7	62.5	-	44.8	60.4	-	42.6	57.9	-	39.6	54.7
3375 Cfm	EAT (wb)	58	TC	92.7	92.7	104.9	88.8	88.8	100.5	84.6	84.6	95.7	79.6	79.6	90.0
			SHC	80.5	92.7	104.9	77.1	88.8	100.5	73.4	84.6	95.7	69.1	79.6	90.0
		62	TC	93.7	93.7	107.3	89.1	89.1	104.7	84.6	84.6	99.5	79.6	79.6	93.6
			SHC	75.8	91.6	107.3	73.5	89.1	104.7	69.8	84.6	99.5	65.6	79.6	93.6
		67	TC	101.5	101.5	101.5	96.7	96.7	96.7	91.3	91.3	91.3	84.8	84.8	85.7
			SHC	60.8	76.9	93.0	58.8	74.9	91.0	56.7	72.8	88.9	53.9	69.8	85.7
		72	TC	109.4	109.4	109.4	104.3	104.3	104.3	98.4	98.4	98.4	90.9	90.9	90.9
			SHC	44.6	60.5	76.4	42.8	58.6	74.4	40.5	56.2	71.8	37.7	52.8	68.0
		76	TC	-	115.1	115.1	-	109.5	109.5	-	102.8	102.8	-	94.0	94.0
			SHC	-	47.8	64.9	-	45.9	62.7	-	43.5	60.1	-	40.4	56.5
3750 Cfm	EAT (wb)	58	TC	95.3	95.3	107.8	91.3	91.3	103.3	86.9	86.9	98.3	81.7	81.7	92.4
			SHC	82.7	95.3	107.8	79.3	91.3	103.3	75.5	86.9	98.3	70.9	81.7	92.4
		62	TC	95.5	95.5	112.2	91.3	91.3	107.4	87.0	87.0	102.2	81.7	81.7	96.0
			SHC	78.7	95.5	112.2	75.3	91.3	107.4	71.7	87.0	102.2	67.4	81.7	96.0
		67	TC	102.8	102.8	102.8	97.9	97.9	97.9	92.3	92.3	94.0	85.7	85.7	90.5
			SHC	63.1	80.6	98.2	61.2	78.7	96.3	59.0	76.5	94.0	56.0	73.2	90.5
		72	TC	110.6	110.6	110.6	105.4	105.4	105.4	99.2	99.2	99.2	91.5	91.5	91.5
			SHC	45.5	62.7	79.9	43.5	60.7	77.8	41.3	58.1	75.0	38.3	54.5	70.7
		76	TC	-	116.1	116.1	-	110.3	110.3	-	103.5	103.5	-	94.5	94.5
			SHC	-	48.9	67.0	-	46.8	64.8	-	44.4	62.0	-	41.1	58.1

48TC

LEGEND:

- Do not operate in this region
- Cfm - Cubic feet per minute (supply air)
- EAT(db) - Entering air temperature (dry bulb)
- EAT(wb) - Entering air temperature (wet bulb)
- SHC - Sensible heat capacity
- TC - Total capacity

TABLE 17 – COOLING CAPACITIES

2-STAGE COOLING

7.5 TONS

48TC*D08			AMBIENT TEMPERATURE												
			85			95			105			115			
			EAT (db)			EAT (db)			EAT (db)			EA (db)			
			75	80	85	75	80	85	75	80	85	75	80	85	
2250 Cfm	EAT (wb)	58	TC	77.4	77.4	87.8	73.8	73.8	83.8	70.1	70.1	79.5	66.0	66.0	74.9
		SHC	66.9	77.4	87.8	63.9	73.8	83.8	60.6	70.1	79.5	57.1	66.0	74.9	
		62	TC	82.2	82.2	83.9	77.5	77.5	81.7	72.6	72.6	79.2	67.3	67.3	76.4
		SHC	60.8	72.4	83.9	58.6	70.1	81.7	56.3	67.7	79.2	53.6	65.0	76.4	
		67	TC	90.1	90.1	90.1	86.0	86.0	86.0	81.4	81.4	81.4	75.9	75.9	75.9
	SHC	50.2	61.8	73.3	48.5	60.1	71.6	46.5	58.1	69.7	44.2	55.8	67.4		
	72	TC	98.0	98.0	98.0	94.0	94.0	94.0	89.5	89.5	89.5	84.3	84.3	84.3	
	SHC	39.1	50.7	62.4	37.5	49.2	60.9	35.8	47.5	59.2	33.8	45.5	57.2		
	76	TC	-	104.3	104.3	-	100.4	100.4	-	95.9	95.9	-	90.7	90.7	
	SHC	-	41.7	54.0	-	40.3	52.7	-	38.7	51.0	-	36.8	49.0		
2625 Cfm	EAT (wb)	58	TC	82.1	82.1	93.2	78.4	78.4	89.0	74.4	74.4	84.4	70.0	70.0	79.5
		SHC	71.0	82.1	93.2	67.8	78.4	89.0	64.3	74.4	84.4	60.6	70.0	79.5	
		62	TC	84.9	84.9	91.8	80.4	80.4	89.5	75.4	75.4	86.7	70.2	70.2	82.9
		SHC	65.4	78.6	91.8	63.2	76.3	89.5	60.6	73.7	86.7	57.6	70.2	82.9	
		67	TC	92.5	92.5	92.5	88.3	88.3	88.3	83.6	83.6	83.6	78.3	78.3	78.3
	SHC	53.0	66.3	79.5	51.3	64.6	78.0	49.4	62.8	76.1	47.2	60.6	73.9		
	72	TC	100.4	100.4	100.4	96.4	96.4	96.4	91.7	91.7	91.7	86.4	86.4	86.4	
	SHC	40.2	53.5	66.7	38.7	52.0	65.3	36.9	50.3	63.7	35.0	48.4	61.8		
	76	TC	-	106.5	106.5	-	102.6	102.6	-	98.0	98.0	-	92.7	92.7	
	SHC	-	43.3	57.6	-	41.8	55.9	-	40.2	54.1	-	38.4	52.2		
3000 Cfm	EAT (wb)	58	TC	85.7	85.7	97.3	82.2	82.2	93.3	78.0	78.0	88.6	73.5	73.5	83.4
		SHC	74.1	85.7	97.3	71.1	82.2	93.3	67.5	78.0	88.6	63.6	73.5	83.4	
		62	TC	86.9	86.9	98.7	82.8	82.8	96.4	78.2	78.2	92.3	73.6	73.6	86.9
		SHC	69.3	84.0	98.7	67.2	81.8	96.4	64.1	78.2	92.3	60.3	73.6	86.9	
		67	TC	94.3	94.3	94.3	90.1	90.1	90.1	85.2	85.2	85.2	79.8	79.8	80.1
	SHC	55.6	70.5	85.4	54.0	68.9	83.9	52.1	67.1	82.2	49.9	65.0	80.1		
	72	TC	102.2	102.2	102.2	98.1	98.1	98.1	93.3	93.3	93.3	87.9	87.9	87.9	
	SHC	41.2	56.0	70.7	39.7	54.6	69.5	38.0	53.0	68.0	36.0	51.1	66.2		
	76	TC	-	108.1	108.1	-	104.2	104.2	-	99.5	99.5	-	94.2	94.2	
	SHC	-	44.5	60.2	-	43.2	58.7	-	41.6	57.0	-	39.8	55.2		
3375 Cfm	EAT (wb)	58	TC	88.5	88.5	100.4	85.0	85.0	96.4	81.0	81.0	92	76.5	76.5	86.8
		SHC	76.5	88.5	100.4	73.5	85.0	96.4	70.1	81.0	92	66.1	76.5	86.8	
		62	TC	88.9	88.9	103.9	85.1	85.1	100.4	81.1	81.1	95.7	76.5	76.5	90.3
		SHC	72.3	88.1	103.9	69.7	85.1	100.4	66.5	81.1	95.7	62.7	76.5	90.3	
		67	TC	95.8	95.8	95.8	91.5	91.5	91.5	86.6	86.6	87.9	81.1	81.1	85.8
	SHC	58.0	74.4	90.9	56.4	73.0	89.6	54.6	71.3	87.9	52.4	69.1	85.8		
	72	TC	103.6	103.6	103.6	99.4	99.4	99.4	94.6	94.6	94.6	89.1	89.1	89.1	
	SHC	42.0	58.3	74.5	40.6	57.0	73.4	38.9	55.5	72.0	37.0	53.7	70.3		
	76	TC	-	109.2	109.2	-	105.4	105.4	-	100.7	100.7	-	95.3	95.3	
	SHC	-	45.6	62.6	-	44.4	61.3	-	42.8	59.7	-	41.0	58.0		
3750 Cfm	EAT (wb)	58	TC	90.8	90.8	103.0	87.3	87.3	99.1	83.3	83.3	94.5	78.8	78.8	89.4
		SHC	78.5	90.8	103.0	75.5	87.3	99.1	72.0	83.3	94.5	68.2	78.8	89.4	
		62	TC	90.9	90.9	107.2	87.4	87.4	103.1	83.3	83.3	98.4	78.9	78.9	93.1
		SHC	74.5	90.9	107.2	71.6	87.4	103.1	68.3	83.3	98.4	64.7	78.9	93.1	
		67	TC	97.0	97.0	97.0	92.6	92.6	95.1	87.6	87.6	93.4	82.1	82.1	91.2
	SHC	60.3	78.2	96.2	58.8	76.9	95.1	56.9	75.2	93.4	54.8	73.0	91.2		
	72	TC	104.7	104.7	104.7	100.5	100.5	100.5	95.6	95.6	95.6	90.1	90.1	90.1	
	SHC	42.9	60.5	78.1	41.4	59.3	77.1	39.8	57.8	75.9	37.9	56.1	74.3		
	76	TC	-	110.2	110.2	-	106.2	106.2	-	101.6	101.6	-	96.1	96.1	
	SHC	-	46.7	64.8	-	45.4	63.6	-	44.0	62.3	-	42.2	60.6		

LEGEND:

- Do not operate in this region
- Cfm - Cubic feet per minute (supply air)
- EAT(db) - Entering air temperature (dry bulb)
- EAT(wb) - Entering air temperature (wet bulb)
- SHC - Sensible heat capacity
- TC - Total capacity

TABLE 18 – COOLING CAPACITIES

1-STAGE COOLING

8.5 TONS

48TC*A09			AMBIENT TEMPERATURE												
			85			95			105			115			
			EAT (db)			EAT (db)			EAT (db)			EAT (db)			
			75	80	85	75	80	85	75	80	85	75	80	85	
2550 Cfm	EAT (wb)	58	TC	88.1	88.1	99.9	84.1	84.1	95.3	79.6	79.6	90.3	74.9	74.9	84.9
			SHC	76.4	88.1	99.9	72.8	84.1	95.3	69.0	79.6	90.3	64.9	74.9	84.9
		62	TC	93.9	93.9	95.2	88.6	88.6	92.6	82.8	82.8	89.7	76.6	76.6	86.5
			SHC	69.4	82.3	95.2	66.8	79.7	92.6	64.1	76.9	89.7	61.0	73.8	86.5
		67	TC	103.8	103.8	103.8	98.7	98.7	98.7	93.0	93.0	93.0	86.7	86.7	86.7
			SHC	57.8	70.7	83.6	55.6	68.5	81.4	53.1	66.1	79.0	50.5	63.4	76.4
		72	TC	113.1	113.1	113.1	108.0	108.0	108.0	102.4	102.4	102.4	96.1	96.1	96.1
			SHC	45.2	58.3	71.3	43.2	56.3	69.3	41.1	54.1	67.1	38.7	51.7	64.7
		76	TC	-	119.9	119.9	-	114.7	114.7	-	109.0	109.0	-	102.7	102.7
			SHC	-	47.9	61.9	-	46.0	60.1	-	44.1	58.1	-	41.9	55.8
2975 Cfm	EAT (wb)	58	TC	93.6	93.6	106.1	89.3	89.3	101.2	84.6	84.6	96.0	79.6	79.6	90.3
			SHC	81.1	93.6	106.1	77.4	89.3	101.2	73.3	84.6	96.0	69.0	79.6	90.3
		62	TC	97.5	97.5	104.3	92.0	92.0	101.4	86.1	86.1	98.3	79.8	79.8	94.1
			SHC	74.7	89.5	104.3	72.0	86.7	101.4	69.1	83.7	98.3	65.6	79.8	94.1
		67	TC	106.7	106.7	106.7	101.5	101.5	101.5	95.7	95.7	95.7	89.2	89.2	89.2
			SHC	61.0	75.8	90.6	58.8	73.6	88.5	56.4	71.3	86.1	53.8	68.7	83.6
		72	TC	115.8	115.8	115.8	110.6	110.6	110.6	104.9	104.9	104.9	98.4	98.4	98.4
			SHC	46.5	61.3	76.2	44.5	59.4	74.2	42.3	57.2	72.1	40.0	54.8	69.7
		76	TC	-	122.4	122.4	-	117.0	117.0	-	111.1	111.1	-	104.5	104.5
			SHC	-	49.8	66.1	-	47.8	63.9	-	45.7	61.6	-	43.4	59.0
3400 Cfm	EAT (wb)	58	TC	98.1	98.1	111.3	93.7	93.7	106.2	88.9	88.9	100.8	83.7	83.7	94.9
			SHC	85.0	98.1	111.3	81.2	93.7	106.2	77.0	88.9	100.8	72.5	83.7	94.9
		62	TC	100.0	100.0	112.3	94.9	94.9	108.6	89.1	89.1	104.9	83.8	83.8	98.7
			SHC	79.3	95.8	112.3	76.3	92.5	108.6	73.2	89.1	104.9	68.8	83.8	98.7
		67	TC	109.0	109.0	109.0	103.6	103.6	103.6	97.6	97.6	97.6	91.0	91.0	91.0
			SHC	63.9	80.5	97.2	61.8	78.5	95.2	59.4	76.1	92.9	56.8	73.5	90.3
		72	TC	117.9	117.9	117.9	112.5	112.5	112.5	106.6	106.6	106.6	100.0	100.0	100.0
			SHC	47.6	64.1	80.6	45.6	62.1	78.7	43.4	60.0	76.6	41.1	57.6	74.2
		76	TC	-	124.2	124.2	-	118.6	118.6	-	112.5	112.5	-	105.7	105.7
			SHC	-	51.2	69.0	-	49.2	66.7	-	47.0	64.4	-	44.7	61.9
3825 Cfm	EAT (wb)	58	TC	101.6	101.6	115.1	97.2	97.2	110.1	92.3	92.3	104.6	87.0	87.0	98.6
			SHC	88.0	101.6	115.1	84.2	97.2	110.1	80.0	92.3	104.6	75.4	87.0	98.6
		62	TC	101.9	101.9	120.0	97.3	97.3	114.6	92.4	92.4	108.9	87.1	87.1	102.6
			SHC	83.7	101.8	120.0	79.9	97.3	114.6	75.9	92.4	108.9	71.6	87.1	102.6
		67	TC	110.7	110.7	110.7	105.3	105.3	105.3	99.2	99.2	99.3	92.5	92.5	96.7
			SHC	66.7	85.0	103.4	64.6	83.0	101.5	62.2	80.8	99.3	59.6	78.2	96.7
		72	TC	119.4	119.4	119.4	114.0	114.0	114.0	108.0	108.0	108.0	101.3	101.3	101.3
			SHC	48.5	66.6	84.6	46.6	64.7	82.7	44.4	62.6	80.7	42.1	60.2	78.4
		76	TC	-	125.5	125.5	-	119.8	119.8	-	113.6	113.6	-	106.7	106.7
			SHC	-	52.4	71.5	-	50.4	69.3	-	48.2	67.0	-	45.9	64.4
4250 Cfm	EAT (wb)	58	TC	104.4	104.4	118.3	99.9	99.9	113.2	95.0	95.0	107.6	89.5	89.5	101.5
			SHC	90.4	104.4	118.3	86.6	99.9	113.2	82.3	95.0	107.6	77.6	89.5	101.5
		62	TC	104.4	104.4	123.0	99.9	99.9	117.8	95.0	95.0	112.0	89.6	89.6	105.6
			SHC	85.8	104.4	123.0	82.1	99.9	117.8	78.1	95.0	112.0	73.6	89.6	105.6
		67	TC	112.1	112.1	112.1	106.6	106.6	107.5	100.4	100.4	105.3	93.6	93.6	102.7
			SHC	69.2	89.2	109.2	67.2	87.3	107.5	64.9	85.1	105.3	62.3	82.5	102.7
		72	TC	120.7	120.7	120.7	115.1	115.1	115.1	109.0	109.0	109.0	102.2	102.2	102.2
			SHC	49.4	68.9	88.4	47.4	67.0	86.5	45.3	64.9	84.6	42.9	62.6	82.3
		76	TC	-	126.6	126.6	-	120.8	120.8	-	114.5	114.5	-	107.4	107.4
			SHC	-	53.5	73.9	-	51.5	71.7	-	49.3	69.4	-	46.9	66.8

48TC

LEGEND:

- Do not operate in this region
- Cfm - Cubic feet per minute (supply air)
- EAT(db) - Entering air temperature (dry bulb)
- EAT(wb) - Entering air temperature (wet bulb)
- SHC - Sensible heat capacity
- TC - Total capacity

TABLE 19 – COOLING CAPACITIES

1-STAGE COOLING

10 TONS

48TC

48TC*A12			AMBIENT TEMPERATURE												
			85			95			105			115			
			EAT (db)			EAT (db)			EAT (db)			EAT (db)			
			75	80	85	75	80	85	75	80	85	75	80	85	
3000 Cfm	EAT (wb)	58	TC	106.3	106.3	120.5	101.7	101.7	115.2	96.6	96.6	109.4	91.0	91.0	103.1
			SHC	92.2	106.3	120.5	88.2	101.7	115.2	83.8	96.6	109.4	78.9	91.0	103.1
		62	TC	112.5	112.5	115.2	106.5	106.5	112.3	99.9	99.9	109.0	92.7	92.7	105.2
			SHC	83.8	99.5	115.2	81.0	96.6	112.3	77.8	93.4	109.0	74.2	89.7	105.2
		67	TC	123.5	123.5	123.5	117.8	117.8	117.8	111.3	111.3	111.3	104.0	104.0	104.0
			SHC	69.2	85.0	100.7	66.8	82.5	98.3	64.1	79.8	95.5	61.0	76.8	92.5
		72	TC	134.3	134.3	134.3	128.5	128.5	128.5	122.0	122.0	122.0	114.7	114.7	114.7
			SHC	53.8	69.6	85.5	51.6	67.4	83.2	49.1	64.9	80.7	46.3	62.1	77.9
		76	TC	-	142.4	142.4	-	136.3	136.3	-	129.5	129.5	-	121.8	121.8
			SHC	-	56.8	73.3	-	54.7	71.2	-	52.3	68.8	-	49.7	66.2
3500 Cfm	EAT (wb)	58	TC	112.9	112.9	127.8	108.0	108.0	122.3	102.7	102.7	116.3	96.8	96.8	109.7
			SHC	97.9	112.9	127.8	93.6	108.0	122.3	89.0	102.7	116.3	83.9	96.8	109.7
		62	TC	116.3	116.3	126.2	110.5	110.5	123.3	103.8	103.8	119.5	97.1	97.1	114.3
			SHC	90.2	108.2	126.2	87.4	105.3	123.3	84.0	101.8	119.5	79.8	97.1	114.3
		67	TC	126.9	126.9	126.9	120.9	120.9	120.9	114.3	114.3	114.3	106.8	106.8	106.8
			SHC	73.2	91.3	109.4	70.8	88.9	107.1	68.1	86.2	104.4	65.0	83.2	101.3
		72	TC	137.5	137.5	137.5	131.4	131.4	131.4	124.7	124.7	124.7	117.2	117.2	117.2
			SHC	55.3	73.4	91.5	53.1	71.1	89.2	50.6	68.7	86.7	47.8	65.9	83.9
		76	TC	-	145.1	145.1	-	138.8	138.8	-	131.7	131.7	-	123.6	123.6
			SHC	-	59.0	78.2	-	56.7	75.8	-	54.3	73.1	-	51.5	70.0
4000 Cfm	EAT (wb)	58	TC	117.8	117.8	133.5	113.0	113.0	128.0	107.5	107.5	121.8	101.5	101.5	115.0
			SHC	102.2	117.8	133.5	98.0	113.0	128.0	93.3	107.5	121.8	88.0	101.5	115.0
		62	TC	119.1	119.1	136.0	113.5	113.5	132.5	107.7	107.7	126.7	101.6	101.6	119.6
			SHC	95.8	115.9	136.0	92.8	112.6	132.5	88.6	107.7	126.7	83.6	101.6	119.6
		67	TC	129.4	129.4	129.4	123.3	123.3	123.3	116.5	116.5	116.5	108.9	108.9	109.8
			SHC	76.9	97.3	117.7	74.5	95.0	115.4	71.8	92.3	112.8	68.8	89.3	109.8
		72	TC	139.7	139.7	139.7	133.5	133.5	133.5	126.6	126.6	126.6	118.8	118.8	118.8
			SHC	56.7	76.8	97.0	54.4	74.6	94.7	51.9	72.1	92.3	49.1	69.3	89.5
		76	TC	-	147.0	147.0	-	140.5	140.5	-	133.2	133.2	-	124.9	124.9
			SHC	-	60.6	81.7	-	58.4	79.3	-	55.8	76.5	-	53.0	73.5
4500 Cfm	EAT (wb)	58	TC	121.7	121.7	137.9	116.8	116.8	132.3	111.2	111.2	126.0	105.0	105.0	118.9
			SHC	105.6	121.7	137.9	101.3	116.8	132.3	96.4	111.2	126.0	91.0	105.0	118.9
		62	TC	121.8	121.8	143.4	116.9	116.9	137.6	111.3	111.3	131.0	105.1	105.1	123.7
			SHC	100.2	121.8	143.4	96.1	116.9	137.6	91.6	111.3	131.0	86.5	105.1	123.7
		67	TC	131.3	131.3	131.3	125.1	125.1	125.1	118.2	118.2	120.8	110.5	110.5	117.7
			SHC	80.3	102.9	125.5	78.0	100.7	123.3	75.3	98.0	120.8	72.3	95.0	117.7
		72	TC	141.5	141.5	141.5	135.1	135.1	135.1	128.0	128.0	128.0	120.1	120.1	120.1
			SHC	57.9	80.0	102.1	55.6	77.7	99.9	53.1	75.2	97.4	50.3	72.4	94.6
		76	TC	-	148.3	148.3	-	141.8	141.8	-	134.3	134.3	-	125.8	125.8
			SHC	-	62.1	84.9	-	59.8	82.5	-	57.3	79.7	-	54.4	76.6
5000 Cfm	EAT (wb)	58	TC	125.0	125.0	141.6	120.0	120.0	135.9	114.3	114.3	129.5	107.9	107.9	122.3
			SHC	108.4	125.0	141.6	104.0	120.0	135.9	99.1	114.3	129.5	93.6	107.9	122.3
		62	TC	125.1	125.1	147.2	120.1	120.1	141.4	114.4	114.4	134.7	108.0	108.0	127.2
			SHC	102.9	125.1	147.2	98.8	120.1	141.4	94.1	114.4	134.7	88.9	108.0	127.2
		67	TC	132.8	132.8	133.0	126.5	126.5	130.8	119.6	119.6	128.2	111.8	111.8	125.1
			SHC	83.6	108.3	133.0	81.2	106.0	130.8	78.6	103.4	128.2	75.6	100.3	125.1
		72	TC	142.8	142.8	142.8	136.3	136.3	136.3	129.1	129.1	129.1	121.1	121.1	121.1
			SHC	59.0	82.9	106.9	56.7	80.7	104.7	54.1	78.2	102.2	51.3	75.4	99.4
		76	TC	-	149.4	149.4	-	142.8	142.8	-	135.1	135.1	-	126.5	126.5
			SHC	-	63.4	87.9	-	61.2	85.5	-	58.6	82.7	-	55.6	79.4

LEGEND:

- Do not operate in this region
- Cfm - Cubic feet per minute (supply air)
- EAT(db) - Entering air temperature (dry bulb)
- EAT(wb) - Entering air temperature (wet bulb)
- SHC - Sensible heat capacity
- TC - Total capacity

TABLE 20 – COOLING CAPACITIES

2-STAGE COOLING

10 TONS

48TC*D12			AMBIENT TEMPERATURE												
			85			95			105			115			
			EAT (db)			EAT (db)			EAT (db)			EAT (db)			
			75	80	85	75	80	85	75	80	85	75	80	85	
3000 Cfm	EAT (wb)	58	TC	107.6	107.6	121.9	102.5	102.5	116.2	96.8	96.8	109.7	90.5	90.5	102.6
			SHC	93.2	107.6	121.9	88.8	102.5	116.2	83.9	96.8	109.7	78.4	90.5	102.6
		62	TC	113.6	113.6	116.5	107.1	107.1	113.4	99.7	99.7	109.8	91.8	91.8	104.9
			SHC	84.6	100.6	116.5	81.5	97.4	113.4	78.0	93.9	109.8	73.7	89.3	104.9
		67	TC	124.4	124.4	124.4	118.4	118.4	118.4	111.5	111.5	111.5	103.3	103.3	103.3
			SHC	69.7	85.7	101.7	67.1	83.2	99.2	64.3	80.3	96.3	60.8	76.8	92.8
		72	TC	135.8	135.8	135.8	129.7	129.7	129.7	122.8	122.8	122.8	115	115	115
			SHC	54.3	70.4	86.6	52.0	68.1	84.2	49.3	65.4	81.6	46.4	62.5	78.6
		76	TC	-	145.3	145.3	-	139	139	-	131.9	131.9	-	124.1	124.1
			SHC	-	57.8	74.3	-	55.6	72.1	-	53.1	69.6	-	50.4	66.9
3500 Cfm	EAT (wb)	58	TC	114.2	114.2	129.4	108.9	108.9	123.4	102.9	102.9	116.6	96.3	96.3	109.1
			SHC	98.9	114.2	129.4	94.3	108.9	123.4	89.1	102.9	116.6	83.4	96.3	109.1
		62	TC	117.2	117.2	127.9	111.0	111.0	124.7	104.0	104.0	119.5	96.5	96.5	113.7
			SHC	91.1	109.5	127.9	88.1	106.4	124.7	83.9	101.7	119.5	79.3	96.5	113.7
		67	TC	127.8	127.8	127.8	121.7	121.7	121.7	114.5	114.5	114.5	106.6	106.6	106.6
			SHC	73.8	92.3	110.8	71.3	89.8	108.3	68.4	87.0	105.5	65.2	83.8	102.3
		72	TC	139.4	139.4	139.4	133.0	133.0	133	125.8	125.8	125.8	117.9	117.9	117.9
			SHC	56.0	74.6	93.1	53.7	72.2	90.8	51.0	69.6	88.2	48.1	66.7	85.4
		76	TC	-	148.8	148.8	-	142.2	142.2	-	134.9	134.9	-	126.8	126.8
			SHC	-	60.2	79.5	-	58.0	77.1	-	55.4	74.5	-	52.7	71.6
4000 Cfm	EAT (wb)	58	TC	119.0	119.0	134.9	114.0	114.0	129.2	108.0	108.0	122.4	101.1	101.1	114.6
			SHC	103.1	119.0	134.9	98.7	114.0	129.2	93.6	108.0	122.4	87.6	101.1	114.6
		62	TC	120.3	120.3	137.1	114.7	114.7	132.8	108.2	108.2	127.5	101.3	101.3	119.3
			SHC	96.5	116.8	137.1	93.0	112.9	132.8	88.9	108.2	127.5	83.2	101.3	119.3
		67	TC	130.5	130.5	130.5	124.1	124.1	124.1	116.8	116.8	116.8	108.7	108.7	111.1
			SHC	77.7	98.6	119.5	75.2	96.2	117.2	72.3	93.3	114.4	69.1	90.1	111.1
		72	TC	142.1	142.1	142.1	135.5	135.5	135.5	128.2	128.2	128.2	120.0	120.0	120.0
			SHC	57.6	78.4	99.3	55.2	76.1	97.1	52.5	73.6	94.6	49.7	70.7	91.8
		76	TC	-	151.4	151.4	-	144.7	144.7	-	137.1	137.1	-	-	-
			SHC	-	62.3	83.8	-	60.0	81.4	-	57.5	78.8	-	-	-
4500 Cfm	EAT (wb)	58	TC	123.0	123.0	139.5	117.8	117.8	133.6	111.9	111.9	126.9	105.3	105.3	119.3
			SHC	106.6	123.0	139.5	102.1	117.8	133.6	97.0	111.9	126.9	91.2	105.3	119.3
		62	TC	123.4	123.4	144.4	117.9	117.9	139.0	112.0	112.0	132.0	105.4	105.4	124.2
			SHC	100.9	122.7	144.4	96.9	117.9	139	92.1	112.0	132	86.6	105.4	124.2
		67	TC	132.6	132.6	132.6	126.0	126	126.0	118.7	118.7	122.9	110.4	110.4	119.6
			SHC	81.4	104.6	127.9	78.9	102.3	125.7	76.1	99.5	122.9	72.9	96.2	119.6
		72	TC	144.2	144.2	144.2	137.4	137.4	137.4	129.9	129.9	129.9	121.6	121.6	121.6
			SHC	59.0	82.1	105.2	56.6	79.8	103.1	54.0	77.3	100.7	51.1	74.5	98
		76	TC	-	153.4	153.4	-	146.6	146.6	-	138.9	138.9	-	-	-
			SHC	-	64.1	87.8	-	61.9	85.6	-	59.4	83	-	-	-
5000 Cfm	EAT (wb)	58	TC	126.5	126.5	143.3	121.2	121.2	137.4	115.1	115.1	130.5	108.4	108.4	122.8
			SHC	109.6	126.5	143.3	105.0	121.2	137.4	99.8	115.1	130.5	93.9	108.4	122.8
		62	TC	126.5	126.5	149.1	121.3	121.3	142.9	115.2	115.2	135.8	108.5	108.5	127.8
			SHC	104.0	126.5	149.1	99.7	121.3	142.9	94.7	115.2	135.8	89.1	108.5	127.8
		67	TC	134.2	134.2	135.9	127.5	127.5	133.8	120.1	120.1	131.0	111.9	111.9	127.6
			SHC	84.9	110.4	135.9	82.4	108.1	133.8	79.6	105.3	131	76.4	102.0	127.6
		72	TC	145.8	145.8	145.8	139.0	139.0	139.0	131.3	131.3	131.3	122.9	122.9	122.9
			SHC	60.3	85.6	110.8	57.9	83.4	108.9	55.3	81.0	106.6	52.5	78.2	104
		76	TC	-	155.1	155.1	-	148.2	148.2	-	-	-	-	-	-
			SHC	-	65.9	91.5	-	63.7	89.5	-	-	-	-	-	-

48TC

LEGEND:

- Do not operate in this region
- Cfm - Cubic feet per minute (supply air)
- EAT(db) - Entering air temperature (dry bulb)
- EAT(wb) - Entering air temperature (wet bulb)
- SHC - Sensible heat capacity
- TC - Total capacity

TABLE 21 – COOLING CAPACITIES

2-STAGE COOLING

12.5 TONS

48TC*D14			AMBIENT TEMPERATURE												
			85			95			105			115			
			EAT (db)			EAT (db)			EAT (db)			EAT (db)			
			75	80	85	75	80	85	75	80	85	75	80	85	
3600 Cfm	EAT (wb)	58	TC	127.6	127.6	142.9	121.7	121.7	137.6	115.0	115.0	130	108.3	108.3	122.6
			SHC	110.3	126.6	142.9	105.8	121.7	137.6	99.9	115.0	130	94.1	108.3	122.6
		62	TC	136.1	136.1	136.1	131.1	131.1	131.1	123.8	123.8	124.5	114.9	114.9	120.3
			SHC	96.6	112.8	129.0	94.7	111.2	127.7	91.4	108.0	124.5	87.3	103.8	120.3
		67	TC	146.2	146.2	146.2	142.0	142.0	142.0	136.2	136.2	136.2	128.8	128.8	128.8
			SHC	78.5	94.4	110.3	76.9	93.1	109.2	74.7	91.0	107.3	71.7	88.1	104.6
		72	TC	155.9	155.9	155.9	152.4	152.4	152.4	147.2	147.2	147.2	140.1	140.1	140.1
			SHC	60.1	76.6	93.2	58.7	75.2	91.7	56.8	73.3	89.7	54.2	70.6	87.0
		76	TC	-	163.0	163	-	160.0	160	-	155.1	155.1	-	148.2	148.2
			SHC	-	62.0	81.8	-	61.1	80.9	-	59.5	79.3	-	57.0	76.3
4200 Cfm	EAT (wb)	58	TC	132.2	132.2	149.5	128.2	128.2	144.9	121.9	121.9	137.8	115.0	115.0	130.1
			SHC	115.0	132.2	149.5	111.5	128.2	144.9	106.0	121.9	137.8	99.9	115.0	130.1
		62	TC	139.6	139.6	139.6	134.7	134.7	138	128.0	128.0	135.6	119.1	119.1	131.2
			SHC	102.5	120.8	139	100.8	119.4	138	98.1	116.8	135.6	93.9	112.6	131.2
		67	TC	149.5	149.5	149.5	145.4	145.4	145.4	139.6	139.6	139.6	132.1	132.1	132.1
			SHC	81.8	99.6	117.4	80.6	98.7	116.8	78.5	96.9	115.2	75.7	94.3	112.8
		72	TC	159.0	159.0	159.0	155.5	155.5	155.5	150.3	150.3	150.3	143.1	143.1	143.1
			SHC	61.4	79.6	97.8	60.2	78.5	96.8	58.3	76.7	95	55.8	74.2	92.5
		76	TC	-	165.7	165.7	-	162.8	162.8	-	157.8	157.8	-	150.8	150.8
			SHC	-	64.6	87.7	-	63.5	86.3	-	61.5	83.3	-	58.9	79.9
4800 Cfm	EAT (wb)	58	TC	136.7	136.7	154.5	133.0	133.0	150.3	127.7	127.7	144.3	120.6	120.6	136.4
			SHC	118.9	136.7	154.5	115.7	133.0	150.3	111.0	127.7	144.3	104.9	120.6	136.4
		62	TC	142.2	142.2	147.8	137.4	137.4	147.1	131.0	131.0	144.7	122.8	122.8	140.3
			SHC	107.7	127.8	147.8	106.2	126.7	147.1	103.6	124.2	144.7	99.3	119.8	140.3
		67	TC	152.1	152.1	152.1	148.0	148	148	142.2	142.2	142.2	134.6	134.6	134.6
			SHC	84.8	104.3	123.7	83.8	103.8	123.7	82.0	102.3	122.6	79.4	99.9	120.4
		72	TC	161.3	161.3	161.3	157.8	157.8	157.8	152.5	152.5	152.5	145.4	145.4	145.4
			SHC	62.6	82.2	101.9	61.4	81.4	101.3	59.7	79.7	99.8	57.2	77.3	97.5
		76	TC	-	167.7	167.7	-	164.9	164.9	-	159.9	159.9	-	152.8	152.8
			SHC	-	66.4	91.4	-	65	89.2	-	63.1	86.4	-	60.5	83.1
5400 Cfm	EAT (wb)	58	TC	140.5	140.5	158.8	136.9	136.9	154.7	131.8	131.8	149	125.2	125.2	141.6
			SHC	122.2	140.5	158.8	119	136.9	154.7	114.7	131.8	149	108.9	125.2	141.6
		62	TC	144.3	144.3	155.7	139.6	139.6	155	133.5	133.5	152.4	125.8	125.8	147.8
			SHC	112.2	133.9	155.7	110.9	132.9	155	108.1	130.2	152.4	103.9	125.8	147.8
		67	TC	154.2	154.2	154.2	150.0	150.0	150.0	144.2	144.2	144.2	136.7	136.7	136.7
			SHC	87.6	108.6	129.6	86.8	108.5	130.1	85.2	107.3	129.4	82.8	105.1	127.4
		72	TC	163.1	163.1	163.1	159.7	159.7	159.7	154.3	154.3	154.3	147.1	147.1	147.1
			SHC	63.6	84.6	105.6	62.5	83.9	105.4	60.8	82.5	104.2	58.4	80.2	102
		76	TC	-	169.3	169.3	-	166.5	166.5	-	161.5	161.5	-	154.2	154.2
			SHC	-	67.6	93.7	-	66.4	91.7	-	64.5	89.2	-	61.9	86.1
6000 Cfm	EAT (wb)	58	TC	143.6	143.6	162.3	140.1	140.1	158.3	135.1	135.1	152.7	128.7	128.7	145.5
			SHC	124.9	143.6	162.3	121.8	140.1	158.3	117.5	135.1	152.7	111.9	128.7	145.5
		62	TC	146.1	146.1	162.4	141.7	141.7	161.5	135.6	135.6	159.2	128.8	128.8	151.2
			SHC	116.1	139.3	162.4	114.7	138.1	161.5	112.1	135.6	159.2	106.4	128.8	151.2
		67	TC	155.8	155.8	155.8	151.6	151.6	151.6	145.9	145.9	145.9	138.3	138.3	138.3
			SHC	90.1	112.6	135	89.6	112.8	136	88.3	112.0	135.8	85.9	110.0	134.1
		72	TC	164.5	164.5	164.5	161.2	161.2	161.2	155.8	155.8	155.8	148.5	148.5	148.5
			SHC	64.5	86.7	108.9	63.5	86.3	109.1	61.9	85.1	108.2	59.6	82.9	106.3
		76	TC	-	170.6	170.6	-	167.8	167.8	-	162.8	162.8	-	155.5	155.5
			SHC	-	68.7	95.8	-	67.5	94.1	-	65.7	91.8	-	63.3	88.8

LEGEND:

- Do not operate in this region
- Cfm - Cubic feet per minute (supply air)
- EAT(db) - Entering air temperature (dry bulb)
- EAT(wb) - Entering air temperature (wet bulb)
- SHC - Sensible heat capacity
- TC - Total capacity

TABLE 22 – STATIC PRESSURE ADDERS (FACTORY OPTIONS AND/OR ACCESSORIES)

Economizer

3 – 6 TONS											
CFM (in. wg)	600	800	1000	1250	1500	1750	2000	2250	2500	2750	3000
Vertical Economizer	0.01	0.02	0.04	0.05	0.07	0.09	0.12	0.15	0.18	0.22	0.26
Horizontal Economizer	0.02	0.03	0.04	0.06	0.08	0.10	0.13	0.15	0.18	0.23	0.28

7.5 – 12.5 TONS																
CFM (in. wg)	2250	2500	2750	3000	3250	3500	3750	4000	4250	4500	4750	5000	5250	5500	5750	6000
Vertical Economizer	0.06	0.08	0.09	0.12	0.13	0.15	0.17	0.20	0.22	0.25	0.29	0.33	0.36	0.40	0.44	0.48
Horizontal Economizer	0.08	0.10	0.13	0.15	0.18	0.21	0.25	0.28	0.30	0.34	0.39	0.43	0.47	0.51	0.56	0.60

48TC

Humidi-Mizer

3 – 6 TONS										
CFM (in. wg)	1000	1200	1400	1600	1800	2000	2200	2400	2600	2800
3 Ton	0.04	0.05	0.06	0.07	–	–	–	–	–	–
4 and 5 Ton	–	0.10	0.13	0.16	0.19	0.23	0.25	0.28	0.32	–
6 Ton	–	–	–	–	0.14	0.15	0.17	0.20	0.23	0.25

General fan performance notes:

1. Interpolation is permissible. Do not extrapolate.
2. External static pressure is the static pressure difference between the return duct and the supply duct plus the static pressure caused by any FIOPs or accessories.
3. Tabular data accounts for pressure loss due to clean filters, unit casing, and wet coils. Factory options and accessories may add static pressure losses, as shown in Table 22. Selection software is available, through your salesperson, to help you select the best motor/drive combination for your application.
4. The Fan Performance tables offer motor/drive recommendations. In cases when two motor/drive combinations would work, Carrier recommended the lower horsepower option.
5. For information on the electrical properties of Carrier motors, please see the Electrical information section of this book.
6. For more information on the performance limits of Carrier motors, see the application data section of this book.

FAN PERFORMANCE

TABLE 23 – 48TC04**

1 PHASE

3 TON HORIZONTAL SUPPLY

CFM	AVAILABLE EXTERNAL STATIC PRESSURE (in. wg)									
	0.2		0.4		0.6		0.8		1.0	
	RPM	BHP	RPM	BHP	RPM	BHP	RPM	BHP	RPM	BHP
	Field–Supplied Drive¹		Standard Static Option				Medium Static Option			
900	553	0.14	681	0.22	782	0.32	870	0.42	948	0.53
975	575	0.16	700	0.25	801	0.35	888	0.46	965	0.57
1050	597	0.18	720	0.28	820	0.38	906	0.49	983	0.61
1125	620	0.21	741	0.31	839	0.42	925	0.54	1001	0.66
1200	643	0.23	762	0.34	859	0.46	944	0.58	1020	0.71
1275	667	0.27	783	0.38	879	0.50	963	0.63	1038	0.76
1350	691	0.30	805	0.42	900	0.55	983	0.68	1057	0.82
1425	715	0.34	827	0.47	920	0.60	1002	0.74	1076	0.88
1500	740	0.38	849	0.52	941	0.66	1023	0.80	1096	0.95

CFM	AVAILABLE EXTERNAL STATIC PRESSURE (in. wg)									
	1.2		1.4		1.6		1.8		2.0	
	RPM	BHP	RPM	BHP	RPM	BHP	RPM	BHP	RPM	BHP
	Medium Static Option				Field–Supplied Drive²					
900	1019	0.64	1084	0.76	1146	0.89	1203	1.02	1258	1.16
975	1036	0.69	1101	0.81	1162	0.94	1219	1.08	–	–
1050	1053	0.74	1118	0.86	1179	1.00	1236	1.14	–	–
1125	1071	0.79	1135	0.92	1196	1.06	1253	1.20	–	–
1200	1089	0.84	1153	0.98	1213	1.12	–	–	–	–
1275	1107	0.90	1171	1.04	1231	1.19	–	–	–	–
1350	1126	0.96	1189	1.11	–	–	–	–	–	–
1425	1144	1.03	1208	1.18	–	–	–	–	–	–
1500	1163	1.10	–	–	–	–	–	–	–	–

NOTE: For more information, see General Fan Performance Notes on page 35.

Boldface indicates field–supplied drive is required.

1. Recommend using field–supplied fan pulley (part no. KR11AG006) and belt (part no. KR30AE039).
2. Recommend using field–supplied motor pulley (part no. KR11HY161) and belt (part no. KR30AE035).

TABLE 24 – 48TC04**

1 PHASE

3 TON VERTICAL SUPPLY

CFM	AVAILABLE EXTERNAL STATIC PRESSURE (in. wg)									
	0.2		0.4		0.6		0.8		1.0	
	RPM	BHP	RPM	BHP	RPM	BHP	RPM	BHP	RPM	BHP
	Field–Supplied Drive¹		Standard Static Option				Medium Static Option			
900	567	0.15	688	0.22	786	0.30	871	0.37	947	0.44
975	591	0.17	710	0.26	807	0.34	891	0.42	966	0.49
1050	615	0.20	732	0.29	828	0.38	911	0.47	985	0.55
1125	641	0.23	755	0.33	849	0.42	931	0.52	1005	0.61
1200	666	0.26	778	0.37	871	0.47	952	0.57	1025	0.67
1275	693	0.29	802	0.41	893	0.53	974	0.63	1046	0.74
1350	719	0.33	826	0.46	916	0.58	995	0.70	1067	0.81
1425	746	0.38	850	0.51	939	0.64	1017	0.76	1088	0.89
1500	773	0.42	875	0.57	963	0.70	1040	0.84	1110	0.96

CFM	AVAILABLE EXTERNAL STATIC PRESSURE (in. wg)									
	1.2		1.4		1.6		1.8		2.0	
	RPM	BHP	RPM	BHP	RPM	BHP	RPM	BHP	RPM	BHP
	Medium Static Option				Field–Supplied Drive²					
900	1016	0.51	1080	0.57	1139	0.64	1195	0.71	1249	0.77
975	1034	0.57	1098	0.64	1157	0.72	1213	0.79	1266	0.86
1050	1053	0.63	1116	0.71	1176	0.79	1231	0.87	1284	0.95
1125	1073	0.70	1135	0.79	1194	0.87	1250	0.96	1302	1.04
1200	1093	0.77	1155	0.87	1213	0.96	1268	1.05	1321	1.14
1275	1113	0.85	1174	0.95	1232	1.05	1287	1.15	–	–
1350	1133	0.92	1194	1.03	1252	1.14	–	–	–	–
1425	1154	1.01	1215	1.12	–	–	–	–	–	–
1500	1175	1.09	–	–	–	–	–	–	–	–

NOTE: For more information, see General Fan Performance Notes on page 35.

Boldface indicates field–supplied drive is required.

1. Recommend using field–supplied fan pulley (part no. KR11AG006) and belt (part no. KR30AE039).
2. Recommend using field–supplied motor pulley (part no. KR11HY161) and belt (part no. KR30AE035).

48TC

FAN PERFORMANCE (cont.)

TABLE 25 – 48TC04**

3 PHASE

3 TON HORIZONTAL SUPPLY

CFM	AVAILABLE EXTERNAL STATIC PRESSURE (in. wg)									
	0.2		0.4		0.6		0.8		1.0	
	RPM	BHP	RPM	BHP	RPM	BHP	RPM	BHP	RPM	BHP
	Field–Supplied Drive ¹		Standard Static Option				Medium Static Option			
900	553	0.14	681	0.22	782	0.32	870	0.42	948	0.53
975	575	0.16	700	0.25	801	0.35	888	0.46	965	0.57
1050	597	0.18	720	0.28	820	0.38	906	0.49	983	0.61
1125	620	0.21	741	0.31	839	0.42	925	0.54	1001	0.66
1200	643	0.23	762	0.34	859	0.46	944	0.58	1020	0.71
1275	667	0.27	783	0.38	879	0.50	963	0.63	1038	0.76
1350	691	0.30	805	0.42	900	0.55	983	0.68	1057	0.82
1425	715	0.34	827	0.47	920	0.60	1002	0.74	1076	0.88
1500	740	0.38	849	0.52	941	0.66	1023	0.80	1096	0.95

CFM	AVAILABLE EXTERNAL STATIC PRESSURE (in. wg)									
	1.2		1.4		1.6		1.8		2.0	
	RPM	BHP	RPM	BHP	RPM	BHP	RPM	BHP	RPM	BHP
	Medium Static Option					High Static Option				
900	1019	0.64	1084	0.76	1146	0.89	1203	1.02	1258	1.16
975	1036	0.69	1101	0.81	1162	0.94	1219	1.08	1274	1.22
1050	1053	0.74	1118	0.86	1179	1.00	1236	1.14	1290	1.28
1125	1071	0.79	1135	0.92	1196	1.06	1253	1.20	1307	1.35
1200	1089	0.84	1153	0.98	1213	1.12	1270	1.27	1324	1.42
1275	1107	0.90	1171	1.04	1231	1.19	1287	1.34	1341	1.50
1350	1126	0.96	1189	1.11	1249	1.26	1305	1.42	1358	1.58
1425	1144	1.03	1208	1.18	1267	1.34	1323	1.50	1376	1.66
1500	1163	1.10	1226	1.25	1285	1.41	1341	1.58	1394	1.75

48TC

NOTE: For more information, see General Fan Performance Notes on page 35.

1. Recommend using field–supplied drive (part no. KR11AG006) and belt (part no. KR30AE039)

TABLE 26 – 48TC04**

3 PHASE

3 TON VERTICAL SUPPLY

CFM	AVAILABLE EXTERNAL STATIC PRESSURE (in. wg)									
	0.2		0.4		0.6		0.8		1.0	
	RPM	BHP	RPM	BHP	RPM	BHP	RPM	BHP	RPM	BHP
	Field–Supplied Drive ¹		Standard Static Option				Medium Static Option			
900	567	0.15	688	0.22	786	0.30	871	0.37	947	0.44
975	591	0.17	710	0.26	807	0.34	891	0.42	966	0.49
1050	615	0.20	732	0.29	828	0.38	911	0.47	985	0.55
1125	641	0.23	755	0.33	849	0.42	931	0.52	1005	0.61
1200	666	0.26	778	0.37	871	0.47	952	0.57	1025	0.67
1275	693	0.29	802	0.41	893	0.53	974	0.63	1046	0.74
1350	719	0.33	826	0.46	916	0.58	995	0.70	1067	0.81
1425	746	0.38	850	0.51	939	0.64	1017	0.76	1088	0.89
1500	773	0.42	875	0.57	963	0.70	1040	0.84	1110	0.96

CFM	AVAILABLE EXTERNAL STATIC PRESSURE (in. wg)									
	1.2		1.4		1.6		1.8		2.0	
	RPM	BHP	RPM	BHP	RPM	BHP	RPM	BHP	RPM	BHP
	Medium Static Option					High Static Option				
900	1016	0.51	1080	0.57	1139	0.64	1195	0.71	1249	0.77
975	1034	0.57	1098	0.64	1157	0.72	1213	0.79	1266	0.86
1050	1053	0.63	1116	0.71	1176	0.79	1231	0.87	1284	0.95
1125	1073	0.70	1135	0.79	1194	0.87	1250	0.96	1302	1.04
1200	1093	0.77	1155	0.87	1213	0.96	1268	1.05	1321	1.14
1275	1113	0.85	1174	0.95	1232	1.05	1287	1.15	1339	1.25
1350	1133	0.92	1194	1.03	1252	1.14	1307	1.25	1358	1.35
1425	1154	1.01	1215	1.12	1272	1.24	1326	1.35	1378	1.46
1500	1175	1.09	1235	1.22	1292	1.34	1346	1.46	1397	1.58

NOTE: For more information, see General Fan Performance Notes on page 35.

Boldface indicates field–supplied drive is required.

1. Recommend using field–supplied fan pulley (part no. KR11AG006) and belt (part no. KR30AE039).

FAN PERFORMANCE (cont.)

TABLE 27 – 48TC05**

1 PHASE

4 TON HORIZONTAL SUPPLY

CFM	AVAILABLE EXTERNAL STATIC PRESSURE (in. wg)									
	0.2		0.4		0.6		0.8		1.0	
	RPM	BHP	RPM	BHP	RPM	BHP	RPM	BHP	RPM	BHP
	Standard Static Option					Medium Static Option				
1200	643	0.23	762	0.34	859	0.46	944	0.58	1020	0.71
1300	675	0.28	790	0.40	886	0.52	969	0.65	1044	0.78
1400	707	0.33	819	0.45	913	0.58	996	0.72	1070	0.86
1500	740	0.38	849	0.52	941	0.66	1023	0.80	1096	0.95
1600	773	0.45	879	0.59	970	0.73	1050	0.88	1123	1.04
1700	807	0.52	910	0.67	999	0.82	1078	0.98	1150	1.14
1800	841	0.59	942	0.75	1029	0.91	1106	1.08	1177	1.25
1900	875	0.68	974	0.85	1059	1.02	1135	1.19	1205	1.37
2000	910	0.77	1006	0.95	1090	1.13	1165	1.31	1234	1.49

48TC

CFM	AVAILABLE EXTERNAL STATIC PRESSURE (in. wg)									
	1.2		1.4		1.6		1.8		2.0	
	RPM	BHP	RPM	BHP	RPM	BHP	RPM	BHP	RPM	BHP
	Medium Static Option					Field-Supplied Drive ¹				
1200	1089	0.84	1153	0.98	1213	1.12	-	-	-	-
1300	1113	0.92	1177	1.06	-	-	-	-	-	-
1400	1138	1.01	1201	1.15	-	-	-	-	-	-
1500	1163	1.10	-	-	-	-	-	-	-	-
1600	1189	1.20	-	-	-	-	-	-	-	-
1700	-	-	-	-	-	-	-	-	-	-
1800	-	-	-	-	-	-	-	-	-	-
1900	-	-	-	-	-	-	-	-	-	-
2000	-	-	-	-	-	-	-	-	-	-

NOTE: For more information, see General Fan Performance Notes on page 35.

Boldface indicates field-supplied drive is required.

1. Recommend using field-supplied motor pulley (part no. KR11HY161) and belt (part no. KR30AE035).

TABLE 28 – 48TC05**

1 PHASE

4 TON VERTICAL SUPPLY

CFM	AVAILABLE EXTERNAL STATIC PRESSURE (in. wg)									
	0.2		0.4		0.6		0.8		1.0	
	RPM	BHP	RPM	BHP	RPM	BHP	RPM	BHP	RPM	BHP
	Standard Static Option					Medium Static Option				
1200	666	0.26	778	0.37	871	0.47	952	0.57	1025	0.67
1300	701	0.31	810	0.43	901	0.54	981	0.65	1053	0.76
1400	737	0.36	842	0.49	931	0.62	1010	0.74	1081	0.86
1500	773	0.42	875	0.57	963	0.70	1040	0.84	1110	0.96
1600	810	0.49	909	0.65	994	0.79	1070	0.94	1140	1.08
1700	847	0.57	943	0.73	1027	0.89	1101	1.05	1170	1.20
1800	885	0.66	978	0.83	1060	1.00	1133	1.16	1200	1.32
1900	923	0.75	1014	0.94	1093	1.11	1165	1.29	1231	1.46
2000	962	0.85	1049	1.05	1127	1.24	1198	1.42	1263	1.61

CFM	AVAILABLE EXTERNAL STATIC PRESSURE (in. wg)									
	1.2		1.4		1.6		1.8		2.0	
	RPM	BHP	RPM	BHP	RPM	BHP	RPM	BHP	RPM	BHP
	Medium Static Option					Field-Supplied Drive ¹				
1200	1093	0.77	1155	0.87	1213	0.96	1268	1.05	1321	1.14
1300	1119	0.87	1181	0.98	1239	1.08	1294	1.18	-	-
1400	1147	0.98	1208	1.09	-	-	-	-	-	-
1500	1175	1.09	-	-	-	-	-	-	-	-
1600	-	-	-	-	-	-	-	-	-	-
1700	-	-	-	-	-	-	-	-	-	-
1800	-	-	-	-	-	-	-	-	-	-
1900	-	-	-	-	-	-	-	-	-	-
2000	-	-	-	-	-	-	-	-	-	-

NOTE: For more information, see General Fan Performance Notes on page 35.

Boldface indicates field-supplied drive is required.

1. Recommend using field-supplied motor pulley (part no. KR11HY161) and belt (part no. KR30AE035).

FAN PERFORMANCE (cont.)

TABLE 29 – 48TC05**

3 PHASE

4 TON HORIZONTAL SUPPLY

CFM	AVAILABLE EXTERNAL STATIC PRESSURE (in. wg)									
	0.2		0.4		0.6		0.8		1.0	
	RPM	BHP	RPM	BHP	RPM	BHP	RPM	BHP	RPM	BHP
	Standard Static Option					Medium Static Option				
1200	643	0.23	762	0.34	859	0.46	944	0.58	1020	0.71
1300	675	0.28	790	0.40	886	0.52	969	0.65	1044	0.78
1400	707	0.33	819	0.45	913	0.58	996	0.72	1070	0.86
1500	740	0.38	849	0.52	941	0.66	1023	0.80	1096	0.95
1600	773	0.45	879	0.59	970	0.73	1050	0.88	1123	1.04
1700	807	0.52	910	0.67	999	0.82	1078	0.98	1150	1.14
1800	841	0.59	942	0.75	1029	0.91	1106	1.08	1177	1.25
1900	875	0.68	974	0.85	1059	1.02	1135	1.19	1205	1.37
2000	910	0.77	1006	0.95	1090	1.13	1165	1.31	1234	1.49

CFM	AVAILABLE EXTERNAL STATIC PRESSURE (in. wg)									
	1.2		1.4		1.6		1.8		2.0	
	RPM	BHP	RPM	BHP	RPM	BHP	RPM	BHP	RPM	BHP
	Medium Static Option					High Static Option				
1200	1089	0.84	1153	0.98	1213	1.12	1270	1.27	1324	1.42
1300	1113	0.92	1177	1.06	1237	1.21	1293	1.36	1347	1.52
1400	1138	1.01	1201	1.15	1261	1.31	1317	1.47	1370	1.63
1500	1163	1.10	1226	1.25	1285	1.41	1341	1.58	1394	1.75
1600	1189	1.20	1252	1.36	1310	1.53	1365	1.70	1418	1.87
1700	1216	1.31	1277	1.48	1335	1.65	1390	1.83	1442	2.01
1800	1242	1.42	1303	1.60	1361	1.78	1415	1.96	1467	2.15
1900	1270	1.55	1330	1.73	1387	1.92	1441	2.11	1493	2.30
2000	1297	1.68	1357	1.87	1414	2.07	1467	2.26	-	-

48TC

NOTE: For more information, see General Fan Performance Notes on page 35.

Boldface indicates field-supplied drive is required.

1. Recommend using field-supplied fan pulley (part no. KR11AZ506), motor pulley (part no. KR11HY181) and belt (part no. KR30AE041).

TABLE 30 – 48TC05**

3 PHASE

4 TON VERTICAL SUPPLY

CFM	AVAILABLE EXTERNAL STATIC PRESSURE (in. wg)									
	0.2		0.4		0.6		0.8		1.0	
	RPM	BHP	RPM	BHP	RPM	BHP	RPM	BHP	RPM	BHP
	Standard Static Option					Medium Static Option				
1200	666	0.26	778	0.37	871	0.47	952	0.57	1025	0.67
1300	701	0.31	810	0.43	901	0.54	981	0.65	1053	0.76
1400	737	0.36	842	0.49	931	0.62	1010	0.74	1081	0.86
1500	773	0.42	875	0.57	963	0.70	1040	0.84	1110	0.96
1600	810	0.49	909	0.65	994	0.79	1070	0.94	1140	1.08
1700	847	0.57	943	0.73	1027	0.89	1101	1.05	1170	1.20
1800	885	0.66	978	0.83	1060	1.00	1133	1.16	1200	1.32
1900	923	0.75	1014	0.94	1093	1.11	1165	1.29	1231	1.46
2000	962	0.85	1049	1.05	1127	1.24	1198	1.42	1263	1.61

CFM	AVAILABLE EXTERNAL STATIC PRESSURE (in. wg)									
	1.2		1.4		1.6		1.8		2.0	
	RPM	BHP	RPM	BHP	RPM	BHP	RPM	BHP	RPM	BHP
	Medium Static Option					High Static Option				
1200	1093	0.77	1155	0.87	1213	0.96	1268	1.05	1321	1.14
1300	1119	0.87	1181	0.98	1239	1.08	1294	1.18	1346	1.28
1400	1147	0.98	1208	1.09	1265	1.21	1320	1.32	1371	1.43
1500	1175	1.09	1235	1.22	1292	1.34	1346	1.46	1397	1.58
1600	1204	1.21	1263	1.35	1320	1.48	1373	1.61	1424	1.74
1700	1233	1.34	1292	1.49	1348	1.63	1401	1.77	1451	1.91
1800	1262	1.48	1321	1.64	1376	1.79	1428	1.94	1479	2.09
1900	1293	1.63	1350	1.79	1405	1.96	1457	2.12	1506	2.28
2000	1323	1.79	1380	1.96	1434	2.13	1486	2.31	-	-

NOTE: For more information, see General Fan Performance Notes on page 35.

Boldface indicates field-supplied drive is required.

1. Recommend using field-supplied fan pulley (part no. KR11AZ506), motor pulley (part no. KR11HY181) and belt (part no. KR30AE041).

FAN PERFORMANCE (cont.)

TABLE 31 – 48TC06**

1 PHASE

5 TON HORIZONTAL SUPPLY

CFM	AVAILABLE EXTERNAL STATIC PRESSURE (in. wg)									
	0.2		0.4		0.6		0.8		1.0	
	RPM	BHP	RPM	BHP	RPM	BHP	RPM	BHP	RPM	BHP
	Standard Static Option									
1500	800	0.39	904	0.49	999	0.60	1087	0.72	1169	0.85
1625	849	0.48	947	0.59	1038	0.70	1122	0.83	1201	0.96
1750	899	0.59	992	0.70	1078	0.82	1159	0.95	1235	1.08
1875	950	0.70	1038	0.82	1120	0.95	1198	1.08	1271	1.22
2000	1001	0.84	1085	0.96	1163	1.09	1238	1.23	1309	1.38
2125	1053	0.99	1133	1.12	1208	1.26	1280	1.40	-	-
2250	1106	1.16	1182	1.29	1254	1.44	-	-	-	-
2375	1159	1.34	1231	1.49	-	-	-	-	-	-
2500	-	-	-	-	-	-	-	-	-	-

48TC

CFM	AVAILABLE EXTERNAL STATIC PRESSURE (in. wg)									
	1.2		1.4		1.6		1.8		2.0	
	RPM	BHP	RPM	BHP	RPM	BHP	RPM	BHP	RPM	BHP
	Medium Static Option									
1500	1247	0.98	1320	1.13	1390	1.28	1457	1.44	-	-
1625	1276	1.10	1348	1.24	1416	1.40	-	-	-	-
1750	1308	1.22	1377	1.38	-	-	-	-	-	-
1875	1342	1.37	-	-	-	-	-	-	-	-
2000	-	-	-	-	-	-	-	-	-	-
2125	-	-	-	-	-	-	-	-	-	-
2250	-	-	-	-	-	-	-	-	-	-
2375	-	-	-	-	-	-	-	-	-	-
2500	-	-	-	-	-	-	-	-	-	-

NOTE: For more information, see General Fan Performance Notes on page 35.
Boldface indicates field-supplied drive is required.

TABLE 32 – 48TC06**

1 PHASE

5 TON VERTICAL SUPPLY

CFM	AVAILABLE EXTERNAL STATIC PRESSURE (in. wg)									
	0.2		0.4		0.6		0.8		1.0	
	RPM	BHP	RPM	BHP	RPM	BHP	RPM	BHP	RPM	BHP
	Standard Static Option								Medium Static Option	
1500	848	0.42	968	0.55	1069	0.68	1158	0.80	1238	0.94
1625	897	0.51	1013	0.65	1111	0.79	1198	0.93	1277	1.07
1750	947	0.61	1059	0.76	1155	0.91	1240	1.06	1318	1.21
1875	997	0.72	1105	0.89	1199	1.05	1283	1.21	1359	1.37
2000	1048	0.85	1153	1.03	1244	1.20	1326	1.37	-	-
2125	1100	1.00	1201	1.19	1290	1.37	-	-	-	-
2250	1152	1.16	1250	1.36	-	-	-	-	-	-
2375	1205	1.34	-	-	-	-	-	-	-	-
2500	-	-	-	-	-	-	-	-	-	-

CFM	AVAILABLE EXTERNAL STATIC PRESSURE (in. wg)									
	1.2		1.4		1.6		1.8		2.0	
	RPM	BHP	RPM	BHP	RPM	BHP	RPM	BHP	RPM	BHP
	Medium Static Option						Field-Supplied Drive¹			
1500	1312	1.07	1380	1.20	1445	1.34	1506	1.48	-	-
1625	1350	1.21	1418	1.35	1482	1.50	-	-	-	-
1750	1390	1.36	-	-	-	-	-	-	-	-
1875	-	-	-	-	-	-	-	-	-	-
2000	-	-	-	-	-	-	-	-	-	-
2125	-	-	-	-	-	-	-	-	-	-
2250	-	-	-	-	-	-	-	-	-	-
2375	-	-	-	-	-	-	-	-	-	-
2500	-	-	-	-	-	-	-	-	-	-

NOTE: For more information, see General Fan Performance Notes on page 35.
Boldface indicates field-supplied drive is required.

1. Recommend using field-supplied motor pulley (part no. KR11HY171) and belt (part no. KR30AE039).

FAN PERFORMANCE (cont.)

TABLE 33 – 48TC06**

3 PHASE

5 TON HORIZONTAL SUPPLY

CFM	AVAILABLE EXTERNAL STATIC PRESSURE (in. wg)									
	0.2		0.4		0.6		0.8		1.0	
	RPM	BHP	RPM	BHP	RPM	BHP	RPM	BHP	RPM	BHP
	Standard Static Option									
1500	800	0.39	904	0.49	999	0.60	1087	0.72	1169	0.85
1625	849	0.48	947	0.59	1038	0.70	1122	0.83	1201	0.96
1750	899	0.59	992	0.70	1078	0.82	1159	0.95	1235	1.08
1875	950	0.70	1038	0.82	1120	0.95	1198	1.08	1271	1.22
2000	1001	0.84	1085	0.96	1163	1.09	1238	1.23	1309	1.38
2125	1053	0.99	1133	1.12	1208	1.26	1280	1.40	1348	1.55
2250	1106	1.16	1182	1.29	1254	1.44	1323	1.59	1389	1.74
2375	1159	1.34	1231	1.49	1300	1.64	1367	1.80	1430	1.96
2500	1212	1.55	1281	1.70	1348	1.86	1412	2.02	1473	2.19

CFM	AVAILABLE EXTERNAL STATIC PRESSURE (in. wg)									
	1.2		1.4		1.6		1.8		2.0	
	RPM	BHP	RPM	BHP	RPM	BHP	RPM	BHP	RPM	BHP
	Medium Static Option								High Static Option	
1500	1247	0.98	1320	1.13	1390	1.28	1457	1.44	1522	1.61
1625	1276	1.10	1348	1.24	1416	1.40	1481	1.56	1544	1.73
1750	1308	1.22	1377	1.38	1444	1.53	1507	1.70	1569	1.87
1875	1342	1.37	1409	1.52	1473	1.69	1536	1.86	1596	2.03
2000	1377	1.53	1442	1.69	1505	1.86	1565	2.03	1624	2.21
2125	1414	1.71	1477	1.87	1538	2.04	1597	2.22	1654	2.40
2250	1452	1.91	1514	2.08	1573	2.25	1630	2.43	1686	2.62
2375	1492	2.12	1551	2.30	1609	2.48	1665	2.66	1719	2.85
2500	1533	2.36	1591	2.54	1647	2.73	-	-	-	-

48TC

NOTE: For more information, see General Fan Performance Notes on page 35.

Boldface indicates field-supplied drive is required.

1. Recommend using field-supplied fan pulley (part no. KR11AZ506), motor pulley (part no. KR11HY191) and belt (part no. KR30AE042).

TABLE 34 – 48TC06**

3 PHASE

5 TON VERTICAL SUPPLY

CFM	AVAILABLE EXTERNAL STATIC PRESSURE (in. wg)									
	0.2		0.4		0.6		0.8		1.0	
	RPM	BHP	RPM	BHP	RPM	BHP	RPM	BHP	RPM	BHP
	Standard Static Option					Medium Static Option				
1500	848	0.42	968	0.55	1069	0.68	1158	0.80	1238	0.94
1625	897	0.51	1013	0.65	1111	0.79	1198	0.93	1277	1.07
1750	947	0.61	1059	0.76	1155	0.91	1240	1.06	1318	1.21
1875	997	0.72	1105	0.89	1199	1.05	1283	1.21	1359	1.37
2000	1048	0.85	1153	1.03	1244	1.20	1326	1.37	1401	1.54
2125	1100	1.00	1201	1.19	1290	1.37	1370	1.55	1444	1.73
2250	1152	1.16	1250	1.36	1336	1.55	1415	1.75	1487	1.94
2375	1205	1.34	1299	1.55	1384	1.76	1460	1.96	1532	2.17
2500	1258	1.54	1349	1.76	1431	1.98	1506	2.20	1576	2.41

CFM	AVAILABLE EXTERNAL STATIC PRESSURE (in. wg)									
	1.2		1.4		1.6		1.8		2.0	
	RPM	BHP	RPM	BHP	RPM	BHP	RPM	BHP	RPM	BHP
	Medium Static Option					High Static Option				
1500	1312	1.07	1380	1.20	1445	1.34	1506	1.48	1564	1.62
1625	1350	1.21	1418	1.35	1482	1.50	1542	1.64	1600	1.79
1750	1390	1.36	1457	1.51	1520	1.67	1580	1.83	1637	1.98
1875	1430	1.53	1496	1.69	1559	1.86	1618	2.02	1675	2.19
2000	1471	1.72	1536	1.89	1598	2.06	1657	2.24	1713	2.41
2125	1513	1.92	1577	2.10	1638	2.28	1696	2.47	1752	2.65
2250	1555	2.13	1619	2.33	1679	2.52	1736	2.72	-	-
2375	1598	2.37	1661	2.57	1720	2.78	-	-	-	-
2500	1642	2.63	1704	2.84	-	-	-	-	-	-

NOTE: For more information, see General Fan Performance Notes on page 35.

Boldface indicates field-supplied drive is required.

1. Recommend using field-supplied fan pulley (part no. KR11AZ506), motor pulley (part no. KR11HY191) and belt (part no. KR30AE042).

FAN PERFORMANCE (cont.)

TABLE 35 – 48TC**07

3 PHASE

6 TON HORIZONTAL SUPPLY

CFM	AVAILABLE EXTERNAL STATIC PRESSURE (in. wg)									
	0.2		0.4		0.6		0.8		1.0	
	RPM	BHP	RPM	BHP	RPM	BHP	RPM	BHP	RPM	BHP
	Field – Supplied Drive¹		Standard Static Option							
1800	913	0.64	1010	0.80	1098	0.98	1178	1.16	1252	1.35
1950	972	0.78	1065	0.96	1148	1.14	1226	1.34	1298	1.54
2100	1032	0.95	1120	1.14	1200	1.33	1275	1.54	1345	1.75
2250	1093	1.14	1177	1.34	1254	1.55	1325	1.76	1393	1.98
2400	1155	1.36	1234	1.57	1308	1.78	1377	2.01	1443	2.24
2550	1217	1.60	1293	1.82	1363	2.05	1430	2.28	1494	2.53
2700	1280	1.87	1352	2.10	1420	2.34	1484	2.59	1546	2.84
2850	1343	2.17	1412	2.42	1477	2.67	1539	2.93	1599	3.19
3000	1406	2.50	1472	2.76	1535	3.03	1595	3.29	1653	3.57

48TC

CFM	AVAILABLE EXTERNAL STATIC PRESSURE (in. wg)									
	1.2		1.4		1.6		1.8		2.0	
	RPM	BHP	RPM	BHP	RPM	BHP	RPM	BHP	RPM	BHP
	Standard Static Option			Medium Static Option				High Static Option		
1800	1322	1.56	1388	1.77	1451	1.98	1510	2.21	1568	2.44
1950	1366	1.75	1430	1.97	1491	2.20	1550	2.43	1606	2.67
2100	1411	1.97	1473	2.20	1533	2.43	1590	2.67	1645	2.92
2250	1457	2.21	1518	2.45	1576	2.69	1632	2.94	1686	3.20
2400	1505	2.48	1564	2.73	1621	2.98	1676	3.24	1729	3.51
2550	1554	2.78	1612	3.03	1667	3.30	1721	3.57	–	–
2700	1604	3.10	1660	3.37	1715	3.64	–	–	–	–
2850	1656	3.46	–	–	–	–	–	–	–	–
3000	–	–	–	–	–	–	–	–	–	–

NOTE: For more information, see General Fan Performance Notes on page 35.

Boldface indicates field – supplied drive is required.

1. Recommend using field – supplied fan pulley (part no. KR11AZ406), motor pulley (part no. KR11HY151) and belt (part no. KR29AF035).

TABLE 36 – 48TC**07

3 PHASE

6 TON VERTICAL SUPPLY

CFM	AVAILABLE EXTERNAL STATIC PRESSURE (in. wg)									
	0.2		0.4		0.6		0.8		1.0	
	RPM	BHP	RPM	BHP	RPM	BHP	RPM	BHP	RPM	BHP
	Field – Supplied Drive¹		Standard Static Option							
1800	967	0.63	1075	0.80	1170	0.97	1255	1.13	1333	1.28
1950	1029	0.77	1132	0.96	1223	1.14	1306	1.32	1382	1.49
2100	1091	0.93	1189	1.14	1278	1.33	1358	1.52	1433	1.71
2250	1154	1.11	1248	1.33	1333	1.55	1411	1.75	1484	1.96
2400	1218	1.32	1308	1.55	1390	1.78	1466	2.01	1537	2.23
2550	1283	1.55	1369	1.80	1448	2.05	1521	2.29	1590	2.52
2700	1348	1.80	1431	2.07	1507	2.33	1578	2.59	1645	2.84
2850	1414	2.09	1493	2.37	1566	2.65	1636	2.92	1701	3.19
3000	1479	2.40	1556	2.70	1627	3.00	1694	3.29	1757	3.57

CFM	AVAILABLE EXTERNAL STATIC PRESSURE (in. wg)									
	1.2		1.4		1.6		1.8		2.0	
	RPM	BHP	RPM	BHP	RPM	BHP	RPM	BHP	RPM	BHP
	Medium Static Option				High Static Option					
1800	1406	1.43	1475	1.58	1540	1.72	1601	1.87	1660	2.00
1950	1454	1.65	1521	1.82	1585	1.98	1645	2.13	1703	2.29
2100	1502	1.89	1568	2.07	1631	2.25	1690	2.42	1747	2.59
2250	1552	2.15	1617	2.35	1678	2.54	1737	2.73	1793	2.92 ²
2400	1603	2.44	1666	2.65	1727	2.86	1784	3.06	1839	3.26
2550	1655	2.75	1717	2.98	1776	3.20	1833	3.42	1887	3.64
2700	1709	3.09	1769	3.33	1827	3.57	–	–	–	–
2850	1763	3.45	–	–	–	–	–	–	–	–
3000	–	–	–	–	–	–	–	–	–	–

NOTE: For more information, see General Fan Performance Notes on page 35.

Boldface indicates field – supplied drive is required.

1. Recommend using field – supplied fan pulley (part no. KR11AZ406), motor pulley (part no. KR11HY151) and belt (part no. KR29AF035).
2. Recommend using field – supplied fan pulley (part no. KR11AZ506), motor pulley (part no. KR11HY191) and belt (part no. KR29AF042).

FAN PERFORMANCE (cont.)

TABLE 37 – 48TC08**

3 PHASE

7.5 TON HORIZONTAL SUPPLY

CFM	AVAILABLE EXTERNAL STATIC PRESSURE (in. wg)									
	0.2		0.4		0.6		0.8		1.0	
	RPM	BHP	RPM	BHP	RPM	BHP	RPM	BHP	RPM	BHP
	Standard Static Option								Medium Static Option	
2250	505	0.52	586	0.73	657	0.97	722	1.22	782	1.50
2438	533	0.62	610	0.85	679	1.09	742	1.36	800	1.65
2625	562	0.74	635	0.98	701	1.23	762	1.51	819	1.81
2813	591	0.88	661	1.13	725	1.39	783	1.68	839	1.98
3000	621	1.03	688	1.29	749	1.57	806	1.87	859	2.18
3188	652	1.21	715	1.48	774	1.77	829	2.07	881	2.40
3375	682	1.40	743	1.68	800	1.98	853	2.30	903	2.63
3563	713	1.61	772	1.91	826	2.22	878	2.55	927	2.89
3750	745	1.85	801	2.15	853	2.48	903	2.82	951	3.18

CFM	AVAILABLE EXTERNAL STATIC PRESSURE (in. wg)									
	1.2		1.4		1.6		1.8		2.0	
	RPM	BHP	RPM	BHP	RPM	BHP	RPM	BHP	RPM	BHP
	Medium Static Option					High Static Option				
2250	838	1.81	891	2.12	941	2.46	988	2.82	1033	3.19
2438	854	1.96	906	2.28	955	2.63	1001	2.99	1046	3.37
2625	872	2.12	922	2.46	970	2.81	1016	3.17	1060	3.56
2813	890	2.31	940	2.65	986	3.01	1031	3.38	1074	3.77
3000	910	2.51	958	2.86	1004	3.23	1048	3.61	1090	4.01
3188	930	2.74	977	3.10	1022	3.47	1065	3.86	1107	4.26¹
3375	951	2.99	997	3.35	1041	3.74	1083	4.13	1124	4.54
3563	973	3.26	1018	3.63	1061	4.02	1103	4.43	–	–
3750	996	3.55	1040	3.93	1082	4.34	–	–	–	–

48TC

NOTE: For more information, see General Fan Performance Notes on page 35.

Boldface indicates field-supplied drive is required.

1. Recommend using field-supplied fan pulley (part no. KR11AZ002) and belt (part no. KR29AF054).

TABLE 38 – 48TC08**

3 PHASE

7.5 TON VERTICAL SUPPLY

CFM	AVAILABLE EXTERNAL STATIC PRESSURE (in. wg)									
	0.2		0.4		0.6		0.8		1.0	
	RPM	BHP	RPM	BHP	RPM	BHP	RPM	BHP	RPM	BHP
	Standard Static Option								Medium Static Option	
2250	513	0.54	595	0.76	665	1.01	728	1.27	786	1.56
2438	541	0.65	620	0.89	688	1.14	750	1.42	806	1.71
2625	570	0.77	645	1.02	712	1.29	772	1.58	827	1.88
2813	600	0.91	672	1.18	736	1.46	794	1.76	848	2.07
3000	629	1.07	699	1.35	761	1.64	818	1.95	871	2.28
3188	660	1.25	726	1.54	787	1.85	842	2.17	894	2.51
3375	690	1.45	754	1.75	813	2.07	867	2.41	917	2.76
3563	721	1.67	783	1.98	840	2.32	892	2.67	941	3.03
3750	752	1.91	812	2.24	867	2.59	918	2.95	966	3.32

CFM	AVAILABLE EXTERNAL STATIC PRESSURE (in. wg)									
	1.2		1.4		1.6		1.8		2.0	
	RPM	BHP	RPM	BHP	RPM	BHP	RPM	BHP	RPM	BHP
	Medium Static Option					High Static Option				
2250	839	1.86	889	2.18	935	2.52	980	2.87	1022	3.23
2438	858	2.02	907	2.35	953	2.70	997	3.06	1039	3.43
2625	878	2.20	926	2.54	972	2.89	1015	3.26	1056	3.64
2813	899	2.40	946	2.75	991	3.11	1033	3.49	1074	3.88
3000	920	2.62	966	2.98	1010	3.35	1052	3.74	1093	4.14
3188	942	2.86	987	3.23	1031	3.61	1072	4.01	1112	4.42¹
3375	964	3.12	1009	3.50	1052	3.89	1093	4.30	–	–
3563	988	3.41	1032	3.80	1074	4.20	1114	4.61	–	–
3750	1011	3.71	1054	4.11	1096	4.53	–	–	–	–

NOTE: For more information, see General Fan Performance Notes on page 35.

Boldface indicates field-supplied drive is required.

1. Recommend using field-supplied fan pulley (part no. KR11AZ002) and belt (part no. KR29AF054).

FAN PERFORMANCE (cont.)

TABLE 39 – 48TC09**

3 PHASE

8.5 TON HORIZONTAL SUPPLY

CFM	AVAILABLE EXTERNAL STATIC PRESSURE (in. wg)									
	0.2		0.4		0.6		0.8		1.0	
	RPM	BHP	RPM	BHP	RPM	BHP	RPM	BHP	RPM	BHP
	Field – Supplied Drive ¹		Standard Static Option						Medium Static Option	
2550	497	0.48	579	0.61	651	0.75	717	0.90	777	1.05
2763	524	0.58	602	0.72	671	0.87	735	1.03	794	1.19
2975	551	0.70	626	0.86	693	1.01	754	1.18	812	1.35
3188	580	0.84	651	1.00	716	1.17	775	1.34	831	1.52
3400	609	1.00	677	1.17	739	1.35	797	1.53	851	1.71
3613	638	1.17	703	1.35	763	1.54	819	1.73	871	1.93
3825	668	1.37	730	1.56	788	1.76	842	1.96	893	2.16
4038	698	1.59	758	1.79	813	2.00	866	2.20	915	2.42
4250	728	1.83	786	2.04	839	2.26	890	2.47	938	2.70

48TC

CFM	AVAILABLE EXTERNAL STATIC PRESSURE (in. wg)									
	1.2		1.4		1.6		1.8		2.0	
	RPM	BHP	RPM	BHP	RPM	BHP	RPM	BHP	RPM	BHP
	Medium Static Option					High Static Option				
2550	833	1.21	886	1.38	936	1.56	984	1.74	1029	1.93
2763	849	1.36	900	1.53	950	1.72	996	1.90	1041	2.10
2975	865	1.52	916	1.70	964	1.89	1010	2.09	1054	2.29
3188	883	1.70	933	1.89	980	2.09	1025	2.29	1068	2.50
3400	902	1.90	950	2.10	996	2.30	1041	2.51	1083	2.73
3613	921	2.13	969	2.33	1014	2.54	1057	2.76	1099	2.98
3825	941	2.37	988	2.58	1032	2.80	1075	3.02	1116	3.25
4038	963	2.63	1008	2.86	1051	3.08	1093	3.31	1133	3.55
4250	984	2.92	1029	3.15	1071	3.39	1112	3.63	1152	3.87

NOTE: For more information, see General Fan Performance Notes on page 35.

Boldface indicates field – supplied drive is required.

1. Recommend using field – supplied fan pulley (part no. KR11AK012) and belt (part no. KR29AF055).
2. Recommend using field – supplied motor pulley (part no. KR11HY310), fan pulley (part no. KR11AZ002) and belt (part no. KR29AF054).

TABLE 40 – 48TC09**

3 PHASE

8.5 TON VERTICAL SUPPLY

CFM	AVAILABLE EXTERNAL STATIC PRESSURE (in. wg)									
	0.2		0.4		0.6		0.8		1.0	
	RPM	BHP	RPM	BHP	RPM	BHP	RPM	BHP	RPM	BHP
	Standard Static Option						Medium Static Option			
2550	526	0.51	600	0.65	666	0.79	727	0.93	783	1.07
2763	557	0.62	627	0.77	690	0.92	749	1.08	804	1.23
2975	588	0.75	655	0.91	716	1.08	772	1.24	825	1.40
3188	621	0.90	684	1.07	743	1.25	797	1.42	848	1.60
3400	653	1.06	714	1.25	770	1.44	822	1.62	872	1.81
3613	687	1.25	744	1.45	798	1.65	849	1.84	897	2.04
3825	720	1.45	775	1.67	827	1.88	876	2.09	922	2.30
4038	754	1.69	807	1.91	856	2.13	904	2.35	949	2.57
4250	788	1.94	839	2.17	886	2.41	932	2.64	976	2.88

CFM	AVAILABLE EXTERNAL STATIC PRESSURE (in. wg)									
	1.2		1.4		1.6		1.8		2.0	
	RPM	BHP	RPM	BHP	RPM	BHP	RPM	BHP	RPM	BHP
	Medium Static Option					High Static Option				
2550	836	1.20	886	1.34	934	1.48	979	1.61	1022	1.74
2763	855	1.37	904	1.52	950	1.67	995	1.82	1037	1.97
2975	875	1.56	923	1.72	968	1.88	1012	2.04	1053	2.20
3188	897	1.77	943	1.94	987	2.11	1030	2.29	1071	2.46
3400	919	1.99	964	2.18	1007	2.36	1049	2.55	1089	2.73¹
3613	943	2.24	986	2.44	1029	2.63	1069	2.83	1108	3.02
3825	967	2.51	1010	2.71	1051	2.92	1090	3.13	1129	3.34
4038	992	2.80	1034	3.02	1074	3.24	1112	3.46	1150	3.68
4250	1018	3.11	1058	3.34	1097	3.57	–	–	–	–

NOTE: For more information, see General Fan Performance Notes on page 35.

Boldface indicates field – supplied drive is required.

1. Recommend using field – supplied motor pulley (part no. KR11HY310), fan pulley (part no. KR11AZ002) and belt (part no. KR29AF054).

FAN PERFORMANCE (cont.)

TABLE 41 – 48TC12**

3 PHASE

10 TON HORIZONTAL SUPPLY

CFM	AVAILABLE EXTERNAL STATIC PRESSURE (in. wg)									
	0.2		0.4		0.6		0.8		1.0	
	RPM	BHP	RPM	BHP	RPM	BHP	RPM	BHP	RPM	BHP
	Field–Supplied Drive ¹		Standard Static Option						Medium Static Option	
3000	579	0.70	660	0.89	732	1.09	799	1.29	860	1.50
3250	613	0.85	690	1.06	760	1.27	823	1.49	883	1.71
3500	648	1.03	721	1.25	788	1.48	850	1.71	907	1.95
3750	683	1.23	753	1.47	817	1.71	877	1.96	933	2.21
4000	719	1.45	786	1.71	848	1.97	905	2.23	959	2.50
4250	756	1.71	819	1.98	879	2.26	934	2.53	987	2.81
4500	792	1.99	853	2.28	910	2.57	964	2.87	1015	3.16
4750	830	2.31	888	2.62	943	2.92	995	3.23	1044	3.54
5000	867	2.66	923	2.98	976	3.30	1026	3.63	1074	3.95

CFM	AVAILABLE EXTERNAL STATIC PRESSURE (in. wg)									
	1.2		1.4		1.6		1.8		2.0	
	RPM	BHP	RPM	BHP	RPM	BHP	RPM	BHP	RPM	BHP
	Medium Static Option						High Static Option			
3000	917	1.70	970	1.91	1021	2.13	1070	2.34	1117	2.56
3250	938	1.93	991	2.16	1041	2.38	1089	2.61	1134	2.85
3500	961	2.18	1013	2.42	1062	2.66	1108	2.91	1153	3.15
3750	985	2.46	1035	2.71	1083	2.97	1129	3.23	1173	3.49
4000	1011	2.76	1059	3.03	1106	3.30	1151	3.58	1194	3.85
4250	1037	3.09	1084	3.38	1130	3.66	1174	3.95	1216	4.24
4500	1064	3.46	1110	3.76	1155	4.06	1198	4.36	1239	4.66
4750	1091	3.85	1137	4.16	1180	4.48	–	–	–	–
5000	1120	4.28	1164	4.61	–	–	–	–	–	–

48TC

NOTE: For more information, see General Fan Performance Notes on page 35.

Boldface indicates field–supplied drive is required.

1. Recommend using field–supplied fan pulley (part no. KR11AD912) and belt (part no. KR29AF051).
2. Recommend using field–supplied motor pulley (part no. KR11HY410).

TABLE 42 – 48TC12**

3 PHASE

10 TON VERTICAL SUPPLY

CFM	AVAILABLE EXTERNAL STATIC PRESSURE (in. wg)									
	0.2		0.4		0.6		0.8		1.0	
	RPM	BHP	RPM	BHP	RPM	BHP	RPM	BHP	RPM	BHP
	Standard Static Option						Medium Static Option			
3000	616	0.79	689	0.97	757	1.16	821	1.36	882	1.57
3250	655	0.96	724	1.16	788	1.37	849	1.58	907	1.80
3500	695	1.17	760	1.38	821	1.60	879	1.83	934	2.06
3750	736	1.41	797	1.63	855	1.86	910	2.10	963	2.35
4000	777	1.68	834	1.91	889	2.16	942	2.41	993	2.67
4250	818	1.98	873	2.23	925	2.49	976	2.75	1025	3.02
4500	860	2.32	912	2.58	962	2.85	1010	3.13	1057	3.41
4750	902	2.69	951	2.97	999	3.26	1046	3.55	1091	3.84
5000	944	3.11	991	3.40	1037	3.70	1082	4.00	1125	4.31

CFM	AVAILABLE EXTERNAL STATIC PRESSURE (in. wg)									
	1.2		1.4		1.6		1.8		2.0	
	RPM	BHP	RPM	BHP	RPM	BHP	RPM	BHP	RPM	BHP
	Medium Static Option						High Static Option			
3000	939	1.79	994	2.01	1047	2.24	1098	2.47	1147	2.71
3250	962	2.03	1015	2.26	1066	2.50	1115	2.75	1163	3.00
3500	987	2.30	1038	2.54	1088	2.80	1135	3.05	1181	3.32
3750	1014	2.60	1063	2.86	1111	3.12	1157	3.39	1202	3.66
4000	1042	2.93	1090	3.20	1136	3.48	1180	3.76	1224	4.04
4250	1072	3.30	1118	3.58	1162	3.87	1205	4.16	–	–
4500	1103	3.70	1147	4.00	1190	4.29	1232	4.60	–	–
4750	1135	4.14	1177	4.45	–	–	–	–	–	–
5000	1167	4.63	–	–	–	–	–	–	–	–

NOTE: For more information, see General Fan Performance Notes on page 35.

Boldface indicates field–supplied drive is required.

1. Recommend using field–supplied motor pulley (part no. KR11HY410).

FAN PERFORMANCE (cont.)

TABLE 43 – 48TC**14

3 PHASE

12.5 TON HORIZONTAL SUPPLY

CFM	AVAILABLE EXTERNAL STATIC PRESSURE (in. wg)									
	0.2		0.4		0.6		0.8		1.0	
	RPM	BHP	RPM	BHP	RPM	BHP	RPM	BHP	RPM	BHP
	Standard Static Option					Medium Static Option				
3438	639	0.98	713	1.20	781	1.43	843	1.65	901	1.88
3750	683	1.23	753	1.47	817	1.71	877	1.96	933	2.21
4063	728	1.52	794	1.78	855	2.04	912	2.31	966	2.57
4375	774	1.85	836	2.13	894	2.41	949	2.70	1001	2.98
4688	820	2.23	879	2.53	935	2.83	987	3.14	1037	3.44
5000	867	2.66	923	2.98	976	3.30	1026	3.63	1074	3.95
5313	914	3.15	967	3.49	1018	3.83	1066	4.17	1112	4.52
5625	962	3.69	1012	4.05	1061	4.42	-	-	-	-
5938	1009	4.30	1058	4.68	-	-	-	-	-	-
6250	-	-	-	-	-	-	-	-	-	-

48TC

CFM	AVAILABLE EXTERNAL STATIC PRESSURE (in. wg)									
	1.2		1.4		1.6		1.8		2.0	
	RPM	BHP	RPM	BHP	RPM	BHP	RPM	BHP	RPM	BHP
	Medium Static Option					High Static Option				
3438	955	2.12	1007	2.35	1056	2.59	1103	2.83	1148	3.08
3750	985	2.46	1035	2.71	1083	2.97	1129	3.23	1173	3.49
4063	1017	2.84	1066	3.12	1112	3.39	1157	3.67	1200	3.95
4375	1050	3.27	1097	3.56	1142	3.86	1186	4.15	1228	4.45
4688	1084	3.75	1130	4.06	1174	4.37	1216	4.68	1257	5.00
5000	1120	4.28	1164	4.61	-	-	1248	5.27	1288	5.60
5313	-	-	-	-	-	-	-	-	-	-
5625	-	-	-	-	-	-	-	-	-	-
5938	-	-	-	-	-	-	-	-	-	-
6250	-	-	-	-	-	-	-	-	-	-

NOTE: For more information, see General Fan Performance Notes on page 35.

Boldface indicates field – supplied drive is required.

TABLE 44 – 48TC**14

3 PHASE

12.5 TON VERTICAL SUPPLY

CFM	AVAILABLE EXTERNAL STATIC PRESSURE (in. wg)									
	0.2		0.4		0.6		0.8		1.0	
	RPM	BHP	RPM	BHP	RPM	BHP	RPM	BHP	RPM	BHP
	Standard Static Option					Medium Static Option				
3438	685	1.12	751	1.32	813	1.54	871	1.76	927	1.99
3750	736	1.41	797	1.63	855	1.86	910	2.10	963	2.35
4063	787	1.75	844	1.99	898	2.24	951	2.49	1001	2.75
4375	839	2.14	892	2.40	943	2.67	993	2.94	1041	3.21
4688	891	2.60	941	2.87	990	3.15	1037	3.44	1082	3.73
5000	944	3.11	991	3.40	1037	3.70	1082	4.00	1125	4.31
5313	997	3.69	1042	4.00	1085	4.32	1128	4.64	-	-
5625	1051	4.34	1093	4.67	-	-	-	-	-	-
5938	-	-	-	-	-	-	-	-	-	-
6250	-	-	-	-	-	-	-	-	-	-

CFM	AVAILABLE EXTERNAL STATIC PRESSURE (in. wg)									
	1.2		1.4		1.6		1.8		2.0	
	RPM	BHP	RPM	BHP	RPM	BHP	RPM	BHP	RPM	BHP
	Medium Static Option					High Static Option				
3438	981	2.23	1032	2.47	1082	2.72	1130	2.97	1177	3.23
3750	1014	2.60	1063	2.86	1111	3.12	1157	3.39	1202	3.66
4063	1049	3.02	1097	3.29	1142	3.57	1186	3.85	1230	4.14
4375	1087	3.49	1132	3.78	1176	4.08	1218	4.37	1260	4.68
4688	1126	4.03	1169	4.33	1211	4.64	-	-	-	-
5000	1167	4.63	-	-	-	-	-	-	-	-
5313	-	-	-	-	-	-	-	-	-	-
5625	-	-	-	-	-	-	-	-	-	-
5938	-	-	-	-	-	-	-	-	-	-
6250	-	-	-	-	-	-	-	-	-	-

NOTE: For more information, see General Fan Performance Notes on page 35.

Boldface indicates field – supplied drive is required.

FAN PERFORMANCE (cont.)

TABLE 45 – PULLEY ADJUSTMENT

UNIT	MOTOR/DRIVE COMBO	MOTOR PULLEY TURNS OPEN											
		0.0	0.5	1.0	1.5	2.0	2.5	3.0	3.5	4.0	4.5	5.0	
04	1 phase	Standard Static	854	825	795	766	736	707	678	648	619	589	560
		Medium Static	1175	1135	1094	1054	1013	973	932	892	851	811	770
		High Static	-	-	-	-	-	-	-	-	-	-	-
	3 phase	Standard Static	854	825	795	766	736	707	678	648	619	589	560
		Medium Static	1175	1135	1094	1054	1013	973	932	892	851	811	770
		High Static	1466	1423	1380	1337	1294	1251	1207	1164	1121	1078	1035
05	1 phase	Standard Static	854	825	795	766	736	707	678	648	619	589	560
		Medium Static	1175	1135	1094	1054	1013	973	932	892	851	811	770
		High Static	-	-	-	-	-	-	-	-	-	-	-
	3 phase	Standard Static	854	825	795	766	736	707	678	648	619	589	560
		Medium Static	1175	1135	1094	1054	1013	973	932	892	851	811	770
		High Static	1466	1423	1380	1337	1294	1251	1207	1164	1121	1078	1035
06	1 phase	Standard Static	1175	1135	1094	1054	1013	973	932	892	851	811	770
		Medium Static	1466	1423	1380	1337	1294	1251	1207	1164	1121	1078	1035
		High Static	-	-	-	-	-	-	-	-	-	-	-
	3 phase	Standard Static	1175	1135	1094	1054	1013	973	932	892	851	811	770
		Medium Static	1466	1423	1380	1337	1294	1251	1207	1164	1121	1078	1035
		High Static	1687	1649	1610	1572	1533	1495	1457	1418	1380	1341	1303
07	3 phase	Standard Static	1457	1419	1380	1342	1303	1265	1227	1188	1150	1111	1073
		Medium Static	1518	1484	1449	1415	1380	1346	1311	1277	1242	1208	1173
		High Static	1788	1757	1725	1694	1662	1631	1600	1568	1537	1505	1474
08	3 phase	Standard Static	747	721	695	670	644	618	592	566	541	515	489
		Medium Static	949	927	906	884	863	841	819	798	776	755	733
		High Static	1102	1083	1063	1044	1025	1006	986	967	948	928	909
09	3 phase	Standard Static	733	712	690	669	647	626	604	583	561	540	518
		Medium Static	936	911	887	862	838	813	788	764	739	715	690
		High Static	1084	1059	1035	1010	986	961	936	912	887	863	838
12	3 phase	Standard Static	838	813	789	764	739	715	690	665	640	616	591
		Medium Static	1084	1059	1035	1010	986	961	936	912	887	863	838
		High Static	1240	1218	1196	1175	1153	1131	1109	1087	1066	1044	1022
14	3 phase	Standard Static	838	813	789	764	739	715	690	665	640	616	591
		Medium Static	1084	1059	1035	1010	986	961	936	912	887	863	838
		High Static	1240	1218	1196	1175	1153	1131	1109	1087	1066	1044	1022

NOTE: Do not adjust pulley further than 5 turns open.

■ - Factory settings

48TC

ECONOMIZER, BAROMETRIC RELIEF AND PE PERFORMANCE

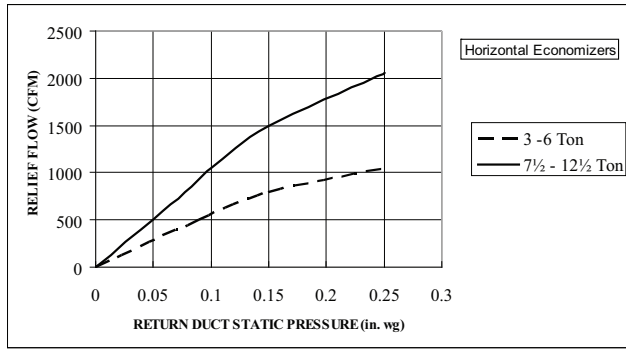

C08070

Fig. 15 - Barometric Relief Flow Capacity

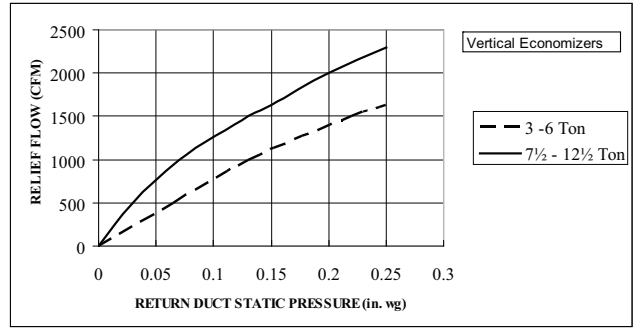

C08073

Fig. 19 - Barometric Relief Flow Capacity

48TC

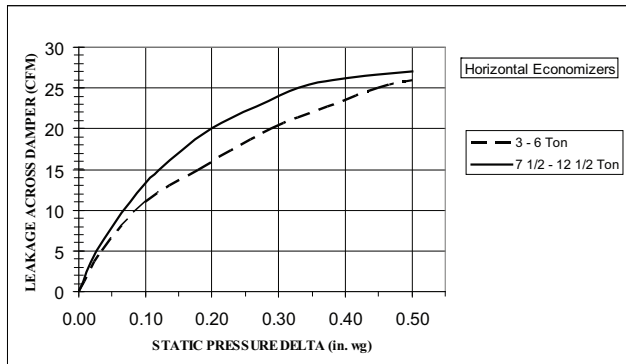

C08071

Fig. 16 - Outdoor Air Damper Leakage

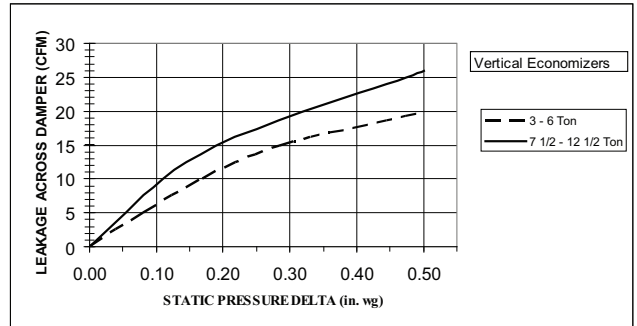

C08074

Fig. 20 - Outdoor Air Damper Leakage

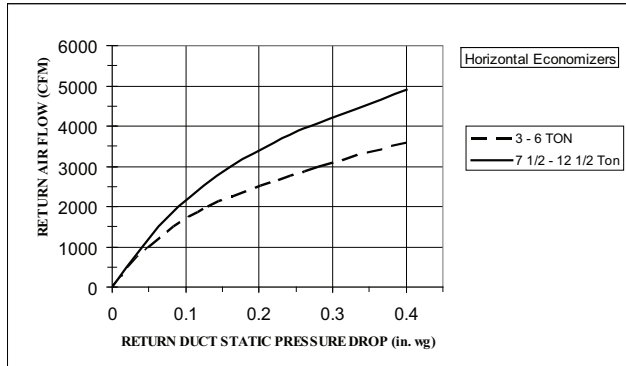

C08072

Fig. 17 - Return Air Pressure Drop

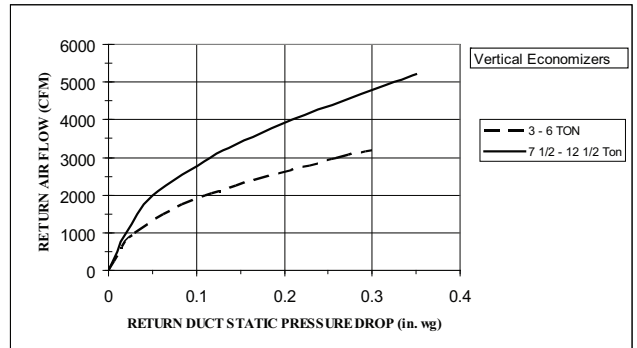

C08075

Fig. 21 - Return Air Pressure Drop

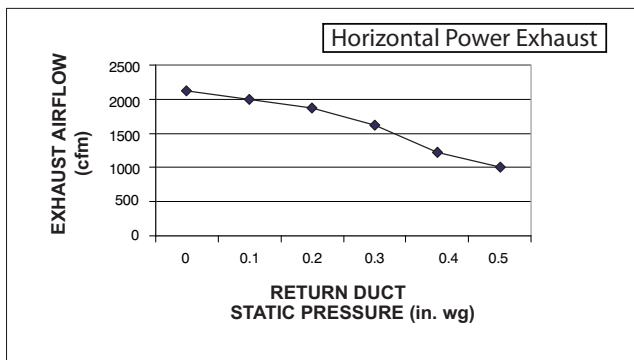

C08012

Fig. 18 - Horizontal Power Exhaust Performance

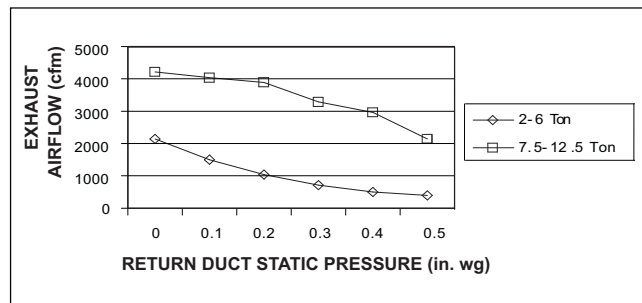

C08013

Fig. 22 - Vertical Power Exhaust Performance

ELECTRICAL INFORMATION

TABLE 46 – 48TC*A04
1-STAGE COOLING
3 TONS

V-Ph-Hz	VOLTAGE RANGE		COMP (ea)		OFM (ea)		IFM				
	MIN	MAX	RLA	LRA	WATTS	FLA	TYPE	Max WATTS	Max AMP Draw	EFF at Full Load	FLA
208-1-60	187	253	16.6	79	325	1.5	Std Static	1000	5.1	70%	4.9
							Med Static	1000	5.1	70%	4.9
230-1-60	187	253	16.6	79	325	1.5	Std Static	1000	5.1	70%	4.9
							Med Static	1000	5.1	70%	4.9
208-3-60	187	253	10.4	73	325	1.5	Std Static	1000	5.1	70%	4.9
							Med Static	1000	5.1	70%	4.9
							High Static	2120	5.5	80%	5.2
230-3-60	187	253	10.4	73	325	1.5	Std Static	1000	5.1	70%	4.9
							Med Static	1000	5.1	70%	4.9
							High Static	2120	5.5	80%	5.2
460-3-60	414	506	5.8	38	325	0.8	Std Static	1000	2.2	70%	2.1
							Med Static	1000	2.2	70%	2.1
							High Static	2120	2.7	80%	2.6
575-3-60	518	633	3.8	37	325	0.6	Std Static	1000	2.0	71%	1.9
							Med Static	1000	2.0	71%	1.9
							High Static	2120	2.1	80%	2.0

48TC
TABLE 47 – 48TC*A05
1-STAGE COOLING
4 TONS

V-Ph-Hz	VOLTAGE RANGE		COMP (ea)		OFM (ea)		IFM				
	MIN	MAX	RLA	LRA	WATTS	FLA	TYPE	Max WATTS	Max AMP Draw	EFF at Full Load	FLA
208-1-60	187	253	21.8	117	325	1.5	Std Static	1000	5.1	70%	4.9
							Med Static	1850	7.4	78%	7.0
230-1-60	187	253	21.8	117	325	1.5	Std Static	1000	5.1	70%	4.9
							Med Static	1850	7.4	78%	7.0
208-3-60	187	253	13.7	83	325	1.5	Std Static	1000	5.1	70%	4.9
							Med Static	1000	5.1	70%	4.9
							High Static	2120	5.5	80%	5.2
230-3-60	187	253	13.7	83	325	1.5	Std Static	1000	5.1	70%	4.9
							Med Static	1000	5.1	70%	4.9
							High Static	2120	5.5	80%	5.2
460-3-60	414	506	6.2	41	325	0.8	Std Static	1000	2.2	70%	2.1
							Med Static	1000	2.2	70%	2.1
							High Static	2120	2.7	80%	2.6
575-3-60	518	633	4.8	37	325	0.6	Std Static	1000	2.0	71%	1.9
							Med Static	1000	2.2	71%	2.1
							High Static	2120	2.1	80%	2.0

TABLE 48 – 48TC*A06
1-STAGE COOLING
5 TONS

V-Ph-Hz	VOLTAGE RANGE		COMP (ea)		OFM (ea)		IFM				
	MIN	MAX	RLA	LRA	WATTS	FLA	TYPE	Max WATTS	Max AMP Draw	EFF at Full Load	FLA
208-1-60	187	253	26.2	134	325	1.5	Std Static	1000	5.1	70%	4.9
							Med Static	1850	7.4	78%	7.0
230-1-60	187	253	26.2	134	325	1.5	Std Static	1000	5.1	70%	4.9
							Med Static	1850	7.4	78%	7.0
208-3-60	187	253	15.6	110	325	1.5	Std Static	1000	5.1	70%	4.9
							Med Static	2120	5.5	80%	5.2
							High Static	2615	7.9	81%	7.5
230-3-60	187	253	15.6	110	325	1.5	Std Static	1000	5.1	70%	4.9
							Med Static	2120	5.5	80%	5.2
							High Static	2615	7.9	81%	7.5
460-3-60	414	506	7.7	52	325	0.8	Std Static	1000	2.2	70%	2.1
							Med Static	2120	2.7	80%	2.6
							High Static	2615	3.6	81%	3.4
575-3-60	518	633	5.8	39	325	0.6	Std Static	1000	2.0	71%	1.9
							Med Static	1390	2.1	81%	2.0
							High Static	3775	2.9	81%	2.8

ELECTRICAL INFORMATION (cont.)

TABLE 49 – 48TC*A07
1-STAGE COOLING
6 TONS

V-Ph-Hz	VOLTAGE RANGE		COMP (ea)		OFM (ea)		IFM				
	MIN	MAX	RLA	LRA	WATTS	FLA	TYPE	Max WATTS	Max AMP Draw	EFF at Full Load	FLA
208-3-60	187	253	19.0	123	325	1.5	Std Static	2120	5.5	80%	5.2
							Med Static	2615	7.9	81%	7.5
							High Static	2615	7.9	81%	7.5
230-3-60	187	253	19.0	123	325	1.5	Std Static	2120	5.5	80%	5.2
							Med Static	2615	7.9	81%	7.5
							High Static	2615	7.9	81%	7.5
460-3-60	414	506	9.7	62	325	0.8	Std Static	2120	2.7	80%	2.6
							Med Static	2615	3.6	81%	3.4
							High Static	3775	4.6	81%	4.4
575-3-60	518	633	7.4	50	325	0.6	Std Static	2120	2.1	80%	2.0
							Med Static	3775	2.9	81%	2.8
							High Static	3775	2.9	81%	2.8

48TC
TABLE 50 – 48TC*A08
1-STAGE COOLING
7.5 TONS

V-Ph-Hz	VOLTAGE RANGE		COMP (ea)		OFM (ea)		IFM				
	MIN	MAX	RLA	LRA	WATTS	FLA	TYPE	Max WATTS	Max AMP Draw	EFF at Full Load	FLA
208-3-60	187	253	25.0	164	325	1.5	Std Static	1448	5.5	80%	5.2
							Med Static	2278	7.9	81%	7.5
							High Static	4400	15.0	81%	15.0
230-3-60	187	253	25.0	164	325	1.5	Std Static	1448	5.5	80%	5.2
							Med Static	2278	7.9	81%	7.5
							High Static	4400	15.0	81%	15.0
460-3-60	414	506	12.2	100	325	0.8	Std Static	1448	2.7	80%	2.6
							Med Static	2278	3.6	81%	3.4
							High Static	4400	7.4	81%	7.4
575-3-60	518	633	9.0	78	325	0.6	Std Static	1379	2.5	80%	2.4
							Med Static	3775	2.9	81%	2.8
							High Static	4400	5.9	81%	5.6

TABLE 51 – 48TC*D08
2-STAGE COOLING
7.5 TONS

V-Ph-Hz	VOLTAGE RANGE		COMP (Cir 1)		COMP (Cir 2)		OFM (ea)		IFM				
	MIN	MAX	RLA	LRA	RLA	LRA	WATTS	FLA	TYPE	Max WATTS	Max AMP Draw	EFF at Full Load	FLA
208-3-60	187	253	13.6	83	13.6	83	325	1.5	STD	1448	5.5	80%	5.2
									MED	2278	7.9	81%	7.5
									HIGH	4400	15.0	81%	15.0
230-3-60	187	253	13.6	83	13.6	83	325	1.5	STD	1448	5.5	80%	5.2
									MED	2278	7.9	81%	7.5
									HIGH	4400	15.0	81%	15.0
460-3-60	414	506	6.1	41	6.1	41	325	0.8	STD	1448	2.7	80%	2.6
									MED	2278	3.6	81%	3.4
									HIGH	4400	7.4	81%	7.4
575-3-60	518	633	4.2	33	4.2	33	325	0.6	STD	1379	2.5	80%	2.4
									MED	3775	2.9	81%	2.8
									HIGH	4400	5.9	81%	5.6

ELECTRICAL INFORMATION (cont.)

TABLE 52 – 48TC*A09
1-STAGE COOLING
8.5 TONS

V-Ph-Hz	VOLTAGE RANGE		COMP (ea)		OFM (ea)		IFM				
	MIN	MAX	RLA	LRA	WATTS	FLA	TYPE	Max WATTS	Max AMP Draw	EFF at Full Load	FLA
208-3-60	187	253	29.5	195	325	1.5	Std Static	1448	5.5	80%	5.2
							Med Static	2120	5.5	80%	5.2
							High Static	2694	10.5	80%	10.0
230-3-60	187	253	29.5	195	325	1.5	Std Static	1448	5.5	80%	5.2
							Med Static	2120	5.5	80%	5.2
							High Static	2694	10.5	80%	10.0
460-3-60	414	506	14.7	95	325	0.8	Std Static	1448	2.7	80%	2.6
							Med Static	2120	2.7	80%	2.6
							High Static	2694	4.6	80%	4.4
575-3-60	518	633	12.2	80	325	0.6	Std Static	1379	2.5	80%	2.4
							Med Static	1390	2.1	80%	2.0
							High Static	3775	2.9	81%	2.8

48TC
TABLE 53 – 48TC*A12
1-STAGE COOLING
10 TONS

V-Ph-Hz	VOLTAGE RANGE		COMP (ea)		OFM (ea)		IFM				
	MIN	MAX	RLA	LRA	WATTS	FLA	TYPE	Max WATTS	Max AMP Draw	EFF at Full Load	FLA
208-3-60	187	253	30.1	225	325	1.5	Std Static	2120	5.5	80%	5.2
							Med Static	3775	10.5	81%	10.0
							High Static	4400	15.0	81%	15.0
230-3-60	187	253	30.1	225	325	1.5	Std Static	2120	5.5	80%	5.2
							Med Static	3775	10.5	81%	10.0
							High Static	4400	15.0	81%	15.0
460-3-60	414	506	16.7	114	325	0.8	Std Static	2120	2.7	80%	2.6
							Med Static	3775	4.6	81%	4.4
							High Static	4400	7.4	81%	7.4
575-3-60	518	633	12.2	80	325	0.6	Std Static	1390	2.1	80%	2.0
							Med Static	3775	2.9	81%	2.8
							High Static	4400	5.9	81%	5.6

TABLE 54 – 48TC*D12
2-STAGE COOLING
10 TONS

V-Ph-Hz	VOLTAGE RANGE		COMP (Cir 1)		COMP (Cir 2)		OFM (ea)		IFM				
	MIN	MAX	RLA	LRA	RLA	LRA	WATTS	FLA	TYPE	Max WATTS	Max AMP Draw	EFF at Full Load	FLA
208-3-60	187	253	15.6	110	15.9	110	325	1.5	STD	2120	5.5	80%	5.2
									MED	3775	10.5	81%	10.0
									HIGH	4400	15.0	81%	15.0
230-3-60	187	253	15.6	110	15.9	110	325	1.5	STD	2120	5.5	80%	5.2
									MED	3775	10.5	81%	10.0
									HIGH	4400	15.0	81%	15.0
460-3-60	414	506	7.7	52	7.7	52	325	0.8	STD	2120	2.7	80%	2.6
									MED	3775	4.6	81%	4.4
									HIGH	4400	7.4	81%	7.4
575-3-60	518	633	5.8	39	5.7	39	325	0.6	STD	1390	2.1	80%	2.0
									MED	3775	2.9	81%	2.8
									HIGH	4400	5.9	81%	5.6

ELECTRICAL INFORMATION (cont.)

TABLE 55 – 48TC*D14

2-STAGE COOLING

12.5 TONS

V-Ph-Hz	VOLTAGE RANGE		COMP (Cir 1)		COMP (Cir 2)		OFM (ea)		IFM				
	MIN	MAX	RLA	LRA	RLA	LRA	WATTS	FLA	TYPE	Max WATTS	Max AMP Draw	EFF at Full Load	FLA
208-3-60	187	253	19.0	123	22.4	149	1288	6.2	STD	2615	7.9	81%	7.5
									MED	3775	10.5	81%	10.0
									HIGH	4400	15.0	81%	15.0
230-3-60	187	253	19.0	123	22.4	149	1288	6.2	STD	2615	7.9	81%	7.5
									MED	3775	10.5	81%	10.0
									HIGH	4400	15.0	81%	15.0
460-3-60	414	506	9.7	62	10.6	75	1288	3.1	STD	2615	3.6	81%	3.4
									MED	3775	4.6	81%	4.4
									HIGH	4400	7.4	81%	7.4
575-3-60	518	633	7.4	50	7.7	54	1288	2.5	STD	3775	2.9	81%	2.8
									MED	3775	2.9	81%	2.8
									HIGH	4400	5.9	81%	5.6

48TC

TABLE 56 – MCA/MOCP DETERMINATION NO C.O. OR UNPWRD C.O.

UNIT	NOM. V-Ph-Hz	IFM TYPE	COMBUSTION FAN MOTOR FLA	POWER EXHAUST FLA	NO C.O. or UNPWRD C.O.							
					NO P.E.				w/ P.E. (pwrd fr/ unit)			
					MCA	MOCP	DISC. SIZE		MCA	MOCP	DISC. SIZE	
							FLA	LRA			FLA	LRA
48TC*A04	208/230-1-60	STD	0.48	1.9	27.2	40.0	26	95	29.1	45.0	29	97
		MED			27.2	40.0	26	95	29.1	45.0	29	97
	208/230-3-60	STD	0.48	1.9	19.4	25.0	19	89	21.3	30.0	22	91
		MED			19.4	25.0	19	89	21.3	30.0	22	91
		HIGH			19.7	30.0	20	107	21.6	30.0	22	109
	460-3-60	STD	0.25	1.0	10.2	15.0	10	46	11.2	15.0	11	47
		MED			10.2	15.0	10	46	11.2	15.0	11	47
		HIGH			10.7	15.0	11	55	11.7	15.0	12	56
	575-3-60	STD	0.24	1.9	7.3	15.0	7	44	9.2	15.0	9	46
		MED			7.3	15.0	7	44	9.2	15.0	9	46
		HIGH			7.4	15.0	7	50	9.3	15.0	10	52
	48TC*A05	208/230-1-60	STD	0.48	1.9	33.7	50.0	32	133	35.6	50.0	35
MED			33.7			50.0	32	133	35.6	50.0	35	135
208/230-3-60		STD	0.48	1.9	23.5	30.0	23	99	25.4	30.0	25	101
		MED			23.5	30.0	23	99	25.4	30.0	25	101
		HIGH			23.8	30.0	23	117	25.7	30.0	25	119
460-3-60		STD	0.25	1.0	10.7	15.0	10	49	11.7	15.0	12	50
		MED			10.7	15.0	10	49	11.7	15.0	12	50
		HIGH			11.2	15.0	11	58	12.2	15.0	12	59
575-3-60		STD	0.24	1.9	8.5	15.0	8	44	10.4	15.0	11	46
		MED			8.5	15.0	8	44	10.4	15.0	11	46
		HIGH			8.6	15.0	9	50	10.5	15.0	11	52
48TC*A06		208/230-1-60	STD	0.48	1.9	39.2	60.0	37	150	41.1	60.0	40
	MED		41.3			60.0	40	175	43.2	60.0	42	177
	208/230-3-60	STD	0.48	1.9	25.9	30.0	25	126	27.8	40.0	27	128
		MED			26.2	40.0	26	144	28.1	40.0	28	146
		HIGH			28.5	40.0	29	170	30.4	45.0	30	172
	460-3-60	STD	0.25	1.0	12.5	20.0	12	60	13.5	20.0	13	61
		MED			13.0	20.0	13	69	14.0	20.0	14	70
		HIGH			13.8	20.0	14	82	14.8	20.0	15	83
	575-3-60	STD	0.24	1.9	9.8	15.0	10	46	11.7	15.0	12	48
		MED			9.9	15.0	10	52	11.8	15.0	13	54
		HIGH			10.7	15.0	11	63	12.6	15.0	13	65
	48TC*A07	208/230-3-60	STD	0.48	1.9	30.5	45	30	157	32.4	50	32
MED			32.8			50	32	183	34.7	50	34	185
HIGH			32.8			50	32	183	34.7	50	34	185
460-3-60		STD	0.25	1.0	15.5	25	15	79	16.5	25	16	80
		MED			16.3	25	16	92	17.3	25	17	93
		HIGH			17.3	25	17	101	18.3	25	18	102
575-3-60		STD	0.24	1.9	11.9	15	12	63	13.8	20	14	65
		MED			12.7	20	12	74	14.6	20	15	76
		HIGH			12.7	20	12	74	14.6	20	15	76
48TC*A08	208/230-3-60	STD	0.48	3.8	39.5	60	38	191	43.3	60	43	195
		MED			41.8	60	41	228	45.6	60	45	232
		HIGH			49.3	60	49	254	53.1	60	54	258
	460-3-60	STD	0.25	1.8	19.5	30	19	113	21.3	30	21	115
		MED			20.3	30	20	132	22.1	30	22	134
		HIGH			24.3	30	24	145	26.1	30	26	147
	575-3-60	STD	0.24	3.8	14.9	20	14	89	18.7	25	19	93
		MED			15.3	20	15	104	19.1	25	19	108
		HIGH			18.1	25	18	118	21.9	30	23	122

48TC

See notes on next page.

TABLE 56 (cont.) MCA/MOCP DETERMINATION NO C.O. OR UNPWRD C.O.

UNIT	NOM. V-Ph-Hz	IFM TYPE	COMBUSTION FAN MOTOR FLA	POWER EXHAUST FLA	NO C.O. or UNPWRD C.O.							
					NO P.E.				w/ P.E. (pwr fr/ unit)			
					MCA	MOCP	DISC. SIZE		MCA	MOCP	DISC. SIZE	
							FLA	LRA			FLA	LRA
48TC*D08	208/230-3-60	STD	0.48	3.8	38.8	50	41	193	42.6	50	45	197
		MED			41.1	50	43	230	44.9	50	48	234
		HIGH			49.0	60	52	256	52.8	60	56	260
	460-3-60	STD	0.25	1.8	17.9	20	19	95	19.7	25	21	97
		MED			18.7	25	20	114	20.5	25	22	116
		HIGH			23.1	30	24	127	24.9	30	26	129
575-3-60	STD	0.24	3.8	13.1	15	14	77	16.9	20	18	81	
	MED			13.5	15	14	92	17.3	20	19	96	
	HIGH			16.6	20	17	106	20.4	25	22	110	
48TC*A09	208/230-3-60	STD	0.48	3.8	45.1	60	43	222	48.9	60	48	226
		MED			45.1	60	43	233	48.9	60	48	237
		HIGH			49.9	60	49	276	53.7	80	53	280
	460-3-60	STD	0.25	1.8	22.6	30	22	108	24.4	30	24	110
		MED			22.6	30	22	114	24.4	30	24	116
		HIGH			24.4	30	24	136	26.2	30	26	138
575-3-60	STD	0.24	3.8	18.9	30	18	91	22.7	30	23	95	
	MED			18.5	30	18	95	22.3	30	22	99	
	HIGH			19.3	30	19	106	23.1	30	23	110	
48TC*A12	208/230-3-60	STD	0.48	3.8	45.8	60	44	263	49.6	60	48	267
		MED			50.6	60	50	306	54.4	80	54	310
		HIGH			55.6	80	55	315	59.4	80	60	319
	460-3-60	STD	0.25	1.8	25.1	30	24	133	26.9	40	26	135
		MED			26.9	40	26	155	28.7	45	28	157
		HIGH			29.9	45	30	159	31.7	45	32	161
575-3-60	STD	0.24	3.8	18.5	30	18	95	22.3	30	22	99	
	MED			19.3	30	19	106	23.1	30	23	110	
	HIGH			22.1	30	22	120	25.9	30	26	124	
48TC*D12	208/230-3-60	STD	0.48	3.8	43.7	50	46	258	47.5	60	50	262
		MED			48.5	60	51	301	52.3	60	56	305
		HIGH			53.5	60	57	310	57.3	70	61	314
	460-3-60	STD	0.25	1.8	21.5	25	23	123	23.3	30	25	125
		MED			23.3	30	25	145	25.1	30	27	147
		HIGH			26.3	30	28	149	28.1	35	30	151
575-3-60	STD	0.24	3.8	16.2	20	17	93	20.0	25	21	97	
	MED			17.0	20	18	104	20.8	25	22	108	
	HIGH			19.8	25	21	118	23.6	30	25	122	
48TC*D14	208/230-3-60	STD	0.48	3.8	60.7	80	63	360	64.5	80	68	364
		MED			63.2	80	66	377	67.0	80	71	381
		HIGH			68.2	80	72	386	72.0	80	76	390
	460-3-60	STD	0.25	1.8	29.5	40	31	181	31.3	40	33	183
		MED			30.5	40	32	190	32.3	40	34	192
		HIGH			33.5	40	35	194	35.3	45	37	196
575-3-60	STD	0.24	3.8	22.3	30	23	142	26.1	30	28	146	
	MED			22.3	30	23	142	26.1	30	28	146	
	HIGH			25.1	30	27	156	28.9	35	31	100	

48TC

LEGEND:

- C.O. - Convenient outlet
- DISC - Disconnect
- FLA - Full load amps
- IFM - Indoor fan motor
- LRA - Locked rotor amps
- MCA - Minimum circuit amps
- MOCP - Maximum over current protection
- P.E. - Power exhaust
- UNPWRD CO - Unpowered convenient outlet



Example: Supply voltage is 230-3-60



AB = 224 v
BC = 231 v
AC = 226 v

$$\text{Average Voltage} = \frac{(224 + 231 + 226)}{3} = \frac{681}{3} = 227$$

Determine maximum deviation from average voltage.

(AB) 227 - 224 = 3 v

(BC) 231 - 227 = 4 v

(AC) 227 - 226 = 1 v

Maximum deviation is 4 v.

Determine percent of voltage imbalance.

$$\% \text{ Voltage Imbalance} = 100 \times \frac{4}{227} = 1.76\%$$

This amount of phase imbalance is satisfactory as it is below the maximum allowable 2%.

IMPORTANT: If the supply voltage phase imbalance is more than 2%, contact your local electric utility company immediately.

NOTES:

- In compliance with NEC requirements for multimotor and combination load equipment (refer to NEC Articles 430 and 440), the overcurrent protective device for the unit shall be fuse or HACR breaker. Canadian units may be fuse or circuit breaker.
- Unbalanced 3-Phase Supply Voltage**
Never operate a motor where a phase imbalance in supply voltage is greater than 2%. Use the following formula to determine the percentage of voltage imbalance.

$$\% \text{ Voltage Imbalance} = 100 \times \frac{\text{max voltage deviation from average voltage}}{\text{average voltage}}$$

TABLE 57 – MCA/MOCP DETERMINATION W/ PWRD C.O.

UNIT	NOM. V-Ph-Hz	IFM TYPE	COMBUSTION FAN MOTOR FLA	POWER EXHAUST FLA	w/ PWRD C.O.								
					NO P.E.				w/ P.E. (pwrd fr/ unit)				
					MCA	MOCP	DISC. SIZE		MCA	MOCP	DISC. SIZE		
							FLA	LRA			FLA	LRA	
48TC*A04	208/230-1-60	STD	0.48	1.9	32.0	45.0	32	100	33.9	50.0	34	102	
		MED			32.0	45.0	32	100	33.9	50.0	34	102	
	208/230-3-60	STD	0.48	1.9	24.2	30.0	25	94	26.1	30.0	27	96	
		MED			24.2	30.0	25	94	26.1	30.0	27	96	
		HIGH			24.5	30.0	25	112	26.4	30.0	27	114	
	460-3-60	STD	0.25	1.0	12.4	15.0	13	48	13.4	15.0	14	49	
		MED			12.4	15.0	13	48	13.4	15.0	14	49	
		HIGH			12.9	15.0	13	57	13.9	20.0	14	58	
	575-3-60	STD	0.24	1.9	9.0	15.0	9	46	10.9	15.0	11	48	
		MED			9.0	15.0	9	46	10.9	15.0	11	48	
		HIGH			9.1	15.0	9	52	11.0	15.0	12	54	
	48TC*A05	208/230-1-60	STD	0.48	1.9	38.5	60.0	38	138	40.4	60.0	40	140
MED			38.5			60.0	38	138	40.4	60.0	40	140	
208/230-3-60		STD	0.48	1.9	28.3	40.0	29	104	30.2	40.0	31	106	
		MED			28.3	40.0	29	104	30.2	40.0	31	106	
		HIGH			28.6	40.0	29	122	30.5	40.0	31	124	
460-3-60		STD	0.25	1.0	12.9	15.0	13	51	13.9	20.0	14	52	
		MED			12.9	15.0	13	51	13.9	20.0	14	52	
		HIGH			13.4	15.0	14	60	14.4	20.0	15	61	
575-3-60		STD	0.24	1.9	10.2	15.0	10	46	12.1	15.0	13	48	
		MED			10.2	15.0	10	46	12.1	15.0	13	48	
		HIGH			10.3	15.0	10	52	12.2	15.0	13	54	
48TC*A06		208/230-1-60	STD	0.48	1.9	44.0	60.0	43	155	45.9	60.0	45	157
	MED		46.1			60.0	45	180	48.0	60.0	48	182	
	208/230-3-60	STD	0.48	1.9	30.7	45.0	31	131	32.6	45.0	33	133	
		MED			31.0	45.0	31	149	32.9	45.0	33	151	
		HIGH			33.3	45.0	34	175	35.2	50.0	36	177	
	460-3-60	STD	0.25	1.0	14.7	20.0	15	62	15.7	20.0	16	63	
		MED			15.2	20.0	15	71	16.2	20.0	16	72	
		HIGH			16.0	20.0	16	84	17.0	20.0	17	85	
	575-3-60	STD	0.24	1.9	11.5	15.0	12	48	13.4	15.0	14	50	
		MED			11.6	15.0	12	54	13.5	15.0	14	56	
		HIGH			12.4	15.0	13	65	14.3	20.0	15	67	
	48TC*A07	208/230-3-60	STD	0.48	1.9	35.3	50.0	35	162	37.2	50.0	37	164
MED			37.6			50.0	38	188	39.5	50.0	40	190	
HIGH			37.6			50.0	38	188	39.5	50.0	40	190	
460-3-60		STD	0.25	1.0	17.7	25.0	18	81	18.7	25.0	19	82	
		MED			18.5	25.0	19	94	19.5	25.0	20	95	
		HIGH			19.5	25.0	20	103	20.5	30.0	21	104	
575-3-60		STD	0.24	1.9	13.6	20.0	13	65	15.5	20.0	16	67	
		MED			14.4	20.0	14	76	16.3	20.0	17	78	
		HIGH			14.4	20.0	14	76	16.3	20.0	17	78	
48TC*A08		208/230-3-60	STD	0.48	3.8	44.3	60	44	196	48.1	60	48	200
			MED			46.6	60	46	233	50.4	60	51	237
			HIGH			54.1	70	55	259	57.9	80	59	263
	460-3-60	STD	0.25	1.8	21.7	30	21	115	23.5	30	23	117	
		MED			22.5	30	22	134	24.3	30	24	136	
		HIGH			26.5	30	27	147	28.3	40	29	149	
	575-3-60	STD	0.24	3.8	16.6	25	16	91	20.4	25	21	95	
		MED			17.0	25	17	106	20.8	25	21	110	
		HIGH			19.8	25	20	120	23.6	30	24	124	

48TC

See notes on next page.

TABLE 57 (cont.) MCA/MOCP DETERMINATION W/ PWRD C.O.

UNIT	NOM. V-Ph-Hz	IFM TYPE	COMBUSTION FAN MOTOR FLA	POWER EXHAUST FLA	w/ PWRD C.O.								
					NO P.E.				w/ P.E. (pwrd fr/ unit)				
					MCA	MOCP	DISC. SIZE		MCA	MOCP	DISC. SIZE		
							FLA	LRA			FLA	LRA	
48TC*D08	208/230-3-60	STD	0.48	3.8	43.6	50	46	198	47.4	60	51	202	
		MED			45.9	50	49	235	49.7	60	53	239	
		HIGH			53.8	60	58	261	57.6	70	62	265	
	460-3-60	STD	0.25	1.8	20.1	25	21	97	21.9	25	23	99	
		MED			20.9	25	22	116	22.7	25	24	118	
		HIGH			25.3	30	27	129	27.1	30	29	131	
575-3-60	STD	0.24	3.8	14.8	20	16	79	18.6	20	20	83		
	MED			15.2	20	16	94	19.0	25	21	98		
	HIGH			18.3	20	19	108	22.1	25	24	112		
48TC*A09	208/230-3-60	STD	0.48	3.8	49.9	60	49	227	53.7	80	53	231	
		MED			49.9	60	49	238	53.7	80	53	242	
		HIGH			54.7	80	54	281	58.5	80	59	285	
	460-3-60	STD	0.25	1.8	24.8	30	24	110	26.6	40	26	112	
		MED			24.8	30	24	116	26.6	40	26	118	
		HIGH			26.6	40	26	138	28.4	40	28	140	
575-3-60	STD	0.24	3.8	20.6	30	20	93	24.4	30	24	97		
	MED			20.2	30	20	97	24.0	30	24	101		
	HIGH			21.0	30	21	108	24.8	30	25	112		
48TC*A12	208/230-3-60	STD	0.48	3.8	50.6	60	50	268	54.4	80	54	272	
		MED			55.4	80	55	311	59.2	80	59	315	
		HIGH			60.4	80	61	320	64.2	80	65	324	
	460-3-60	STD	0.25	1.8	27.3	40	27	135	29.1	45	29	137	
		MED			29.1	45	29	157	30.9	45	31	159	
		HIGH			32.1	45	32	161	33.9	50	34	163	
575-3-60	STD	0.24	3.8	20.2	30	20	97	24.0	30	24	101		
	MED			21.0	30	21	108	24.8	30	25	112		
	HIGH			23.8	30	24	122	27.6	35	28	126		
48TC*D12	208/230-3-60	STD	0.48	3.8	48.5	60	51	263	52.3	60	56	267	
		MED			53.3	60	57	306	57.1	70	61	310	
		HIGH			58.3	70	62	315	62.1	70	67	319	
	460-3-60	STD	0.25	1.8	23.7	30	25	125	25.5	30	27	127	
		MED			25.5	30	27	147	27.3	30	29	149	
		HIGH			28.5	35	31	151	30.3	35	33	153	
575-3-60	STD	0.24	3.8	17.9	20	19	95	21.7	25	23	99		
	MED			18.7	25	20	106	22.5	25	24	110		
	HIGH			21.5	25	23	120	25.3	30	27	124		
48TC*D14	208/230-3-60	STD	0.48	3.8	65.5	80	69	365	69.3	80	73	369	
		MED			68.0	80	72	382	71.8	80	76	386	
		High	Model not available due to high amperage draw.										
	460-3-60	STD	0.25	1.8	31.7	40	33	183	33.5	40	35	185	
		MED			32.7	40	35	192	34.5	45	37	194	
		HIGH			35.7	45	38	196	37.5	45	40	198	
575-3-60	STD	0.24	3.8	24.0	30	25	144	27.8	30	30	148		
	MED			24.0	30	25	144	27.8	30	30	148		
	HIGH			26.8	30	29	158	30.6	35	33	162		

48TC

LEGEND:

- C.O. - Convenient outlet
- DISC - Disconnect
- FLA - Full load amps
- IFM - Indoor fan motor
- LRA - Locked rotor amps
- MCA - Minimum circuit amps
- MOCP - Maximum over current protection
- P.E. - Power exhaust
- UNPWRD CO - Unpowered convenient outlet



Example: Supply voltage is 230-3-60



AB = 224 v
BC = 231 v
AC = 226 v

$$\text{Average Voltage} = \frac{(224 + 231 + 226)}{3} = \frac{681}{3} = 227$$

Determine maximum deviation from average voltage.

- (AB) 227 - 224 = 3 v
- (BC) 231 - 227 = 4 v
- (AC) 227 - 226 = 1 v

Maximum deviation is 4 v.

Determine percent of voltage imbalance.

$$\% \text{ Voltage Imbalance} = 100 \times \frac{4}{227} = 1.76\%$$

This amount of phase imbalance is satisfactory as it is below the maximum allowable 2%.

IMPORTANT: If the supply voltage phase imbalance is more than 2%, contact your local electric utility company immediately.

NOTES:

1. In compliance with NEC requirements for multimotor and combination load equipment (refer to NEC Articles 430 and 440), the overcurrent protective device for the unit shall be fuse or HACR breaker. Canadian units may be fuse or circuit breaker.
2. **Unbalanced 3-Phase Supply Voltage**
Never operate a motor where a phase imbalance in supply voltage is greater than 2%. Use the following formula to determine the percentage of voltage imbalance.

$$\% \text{ Voltage Imbalance} = 100 \times \frac{\text{max voltage deviation from average voltage}}{\text{average voltage}}$$

TYPICAL WIRING DIAGRAMS

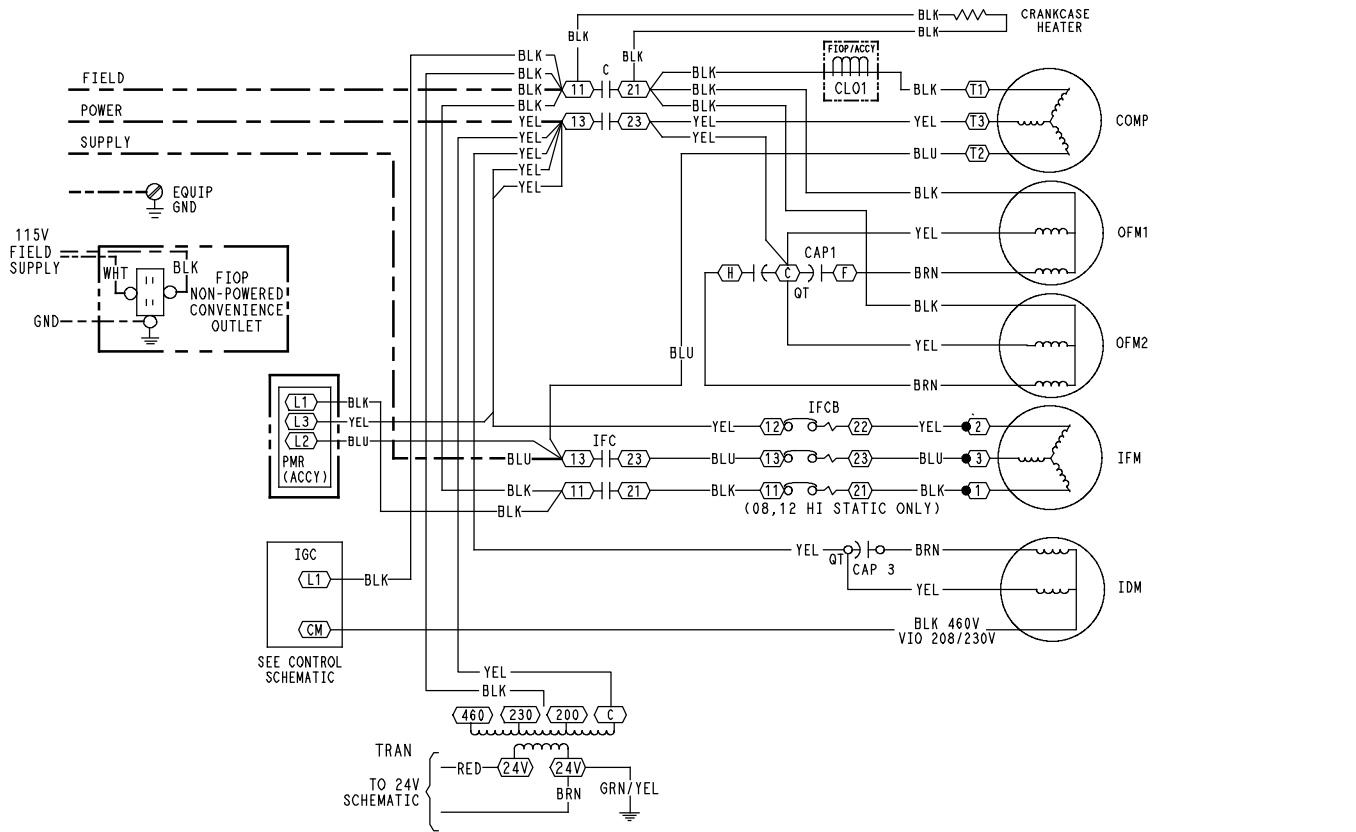

LEGEND

- (X) MARKED WIRE
- (X) TERMINAL (MARKED)
- TERMINAL (UNMARKED)
- [X] TERMINAL BLOCK
- SPLICE
- ◐ SPLICE (MARKED)
- FACTORY WIRING
- - - - FIELD CONTROL WIRING
- - - - FIELD POWER WIRING
- - - - CIRCUIT BOARD TRACE
- ACCESSORY OR OPTIONAL WIRING
- TO INDICATE COMMON POTENTIAL ONLY: NOT TO REPRESENT WIRING

NOTES

1. IF ANY OF THE ORIGINAL WIRE FURNISHED MUST BE REPLACED, IT MUST BE REPLACED WITH TYPE 90 C WIRE OR ITS EQUIVALENT.
2. COMPRESSOR AND FAN MOTORS ARE THERMALLY PROTECTED. THREE PHASE MOTORS ARE PROTECTED AGAINST PRIMARY SINGLE PHASING CONDITIONS.
3. 208/230V UNIT TRAN IS WIRED FOR 230V UNIT. IF UNIT IS TO BE RUN WITH 208V POWER SUPPLY DISCONNECT BLK WIRE FROM 230V TAP AND CONNECT TO 200V TAP.
4. USE COPPER, COPPER CLAD, ALUMINUM OR ALUMINUM CONNECTORS.
5. USE COPPER CONDUCTOR ONLY.

C	CONTACTOR, COMPRESSOR	OAQ	OUTDOOR AIR QUALITY
CAP	CAPACITOR	OAT	OUTDOOR AIR TEMP. SEN
CB	CIRCUIT BREAKER	OFM	OUTDOOR FAN MOTOR
CCH	CRANKCASE HEATER	OL	OVERLOAD
CCN	CARRIER COMFORT NETWORK	PL	PLUG ASSEMBLY
CMP	COMPRESSOR SAFETY	POT	POTENTIOMETER
COMP	COMPRESSOR MOTOR	PMR	PHASE MONITOR RELAY
DDC	DIRECT DIGITAL CONTROL	QT	QUADRUPLE TERMINAL
FSD	FIRE SHUT DOWN	R	RELAY
FU	FUSE	RAT	RETURN AIR TEMP. SEN
GND	GROUND	RMT OCC	REMOTE OCCUPANCY
GVR	GAS VALVE RELAY	RS	ROLLOUT SWITCH
HPS	HIGH PRESSURE SWITCH	SAT	SUPPLY AIR TEMP. SENSOR
HS	HALL EFFECT SENSOR	SEN	SENSOR
I	IGNITOR	SET	SET POINT OFFSET
IAQ	INDOOR AIR QUALITY SENSORS	SFS	SUPPLY FAN STATUS
IFC	INDOOR FAN CONTACTOR	TDR	TIME DELAY RELAY
IFCB	INDOOR FAN CIRCUIT BREAKER	TRAN	TRANSFORMER
IFM	INDOOR FAN MOTOR		
IGC	INTEGRATED GAS CONTROL		
IRH	INDOOR RELATIVE HUMIDITY		
LA	LOW AMBIENT LOCKOUT		
LOOP PWR	CURRENT LOOP POWER		
LPS	LOW PRESSURE SWITCH		
LSM	LIMIT SWITCH (MANUAL RESET)		
MGV	MAIN GAS VALVE		

Fig. 23 - 1-Stage Cooling Typical Power Diagram

C08518

TYPICAL WIRING DIAGRAMS (cont.)

48TC

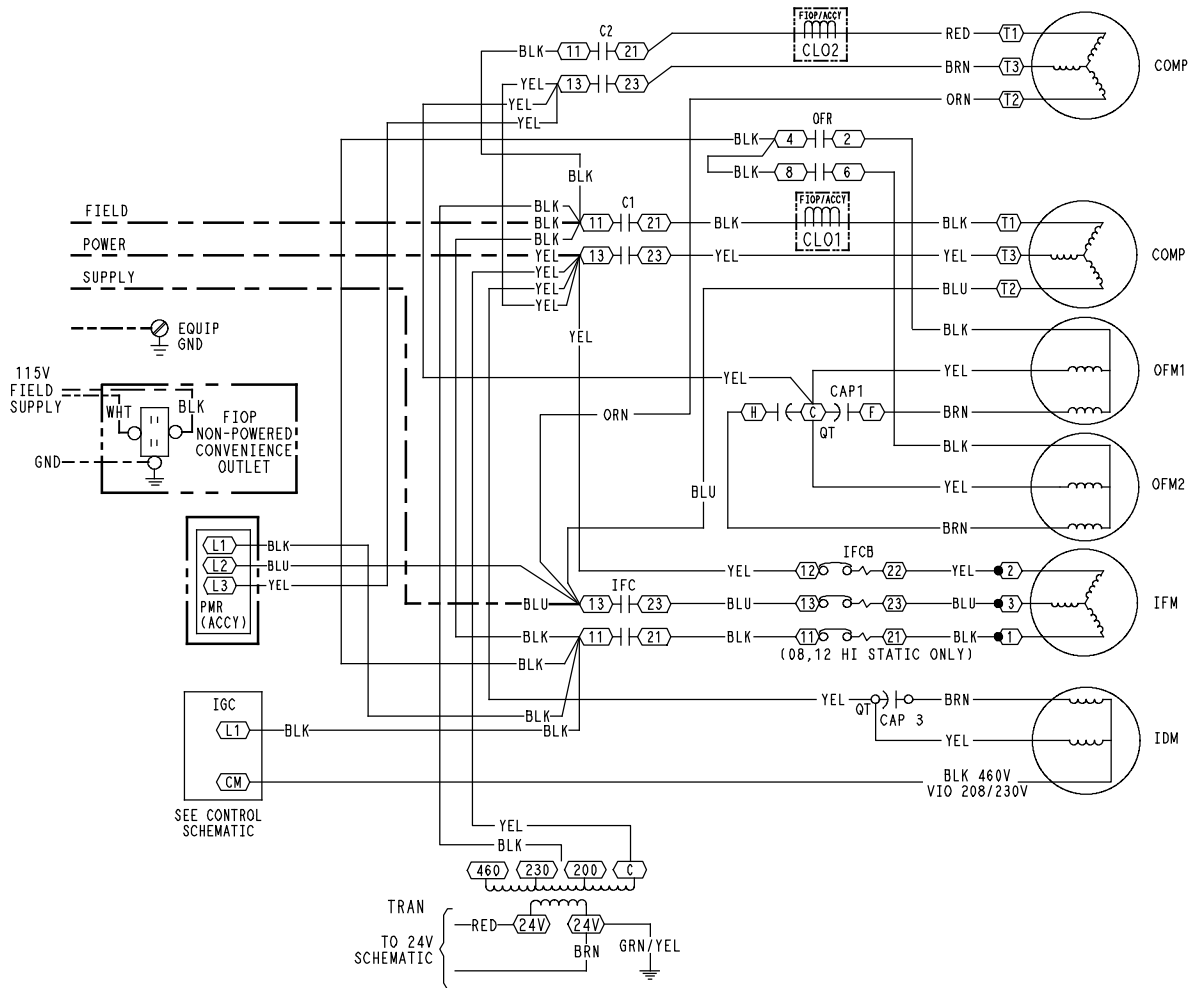

LEGEND

- X MARKED WIRE
- X TERMINAL (MARKED)
- TERMINAL (UNMARKED)
- X TERMINAL BLOCK
- SPLICE
- SPLICE (MARKED)
- FACTORY WIRING
- - - FIELD CONTROL WIRING
- - - - FIELD POWER WIRING
- - - - CIRCUIT BOARD TRACE
- - - - ACCESSORY OR OPTIONAL WIRING
- TO INDICATE COMMON POTENTIAL ONLY: NOT TO REPRESENT WIRING

NOTES

1. IF ANY OF THE ORIGINAL WIRE FURNISHED MUST BE REPLACED. IT MUST BE REPLACED WITH TYPE 90 C WIRE OR ITS EQUIVALENT.
2. COMPRESSOR AND FAN MOTORS ARE THERMALLY PROTECTED. THREE PHASE MOTORS ARE PROTECTED AGAINST PRIMARY SINGLE PHASING CONDITIONS.
3. 208/230V UNIT TRAN IS WIRED FOR 230V UNIT. IF UNIT IS TO BE RUN WITH 208V POWER SUPPLY DISCONNECT BLK WIRE FROM 230V TAP AND CONNECT TO 200V TAP.
4. USE COPPER, COPPER CLAD, ALUMINUM OR ALUMINUM CONNECTORS.
5. USE COPPER CONDUCTOR ONLY.

C	CONTACTOR, COMPRESSOR	OAQ	OUTDOOR AIR QUALITY
CAP	CAPACITOR	OAT	OUTDOOR AIR TEMP. SEN
CB	CIRCUIT BREAKER	OFM	OUTDOOR FAN MOTOR
CCH	CRANKCASE HEATER	OL	OVERLOAD
CCN	CARRIER COMFORT NETWORK	PL	PLUG ASSEMBLY
CMP SAFE	COMPRESSOR SAFETY	POT	POTENTIOMETER
CLO	COMPRESSOR LOCKOUT	PMR	PHASE MONITOR RELAY
COMP	COMPRESSOR MOTOR	QT	QUADRUPLE TERMINAL
DDC	DIRECT DIGITAL CONTROL	R	RELAY
FSD	FIRE SHUT DOWN	RAT	RETURN AIR TEMP. SEN
FS	FLAME SENSOR	RMT OCC	REMOTE OCCUPANCY
FU	FUSE	RS	ROLLOUT SWITCH
GND	GROUND	SAT	SUPPLY AIR TEMP. SENSOR
GVR	GAS VALVE RELAY	SEN	SENSOR
HPS	HIGH PRESSURE SWITCH	SET	SET POINT OFFSET
HS	HALL EFFECT SENSOR	SFS	SUPPLY FAN STATUS
I	IGNITOR	TDR	TIME DELAY RELAY
IAQ	INDOOR AIR QUALITY SENSORS	TRAN	TRANSFORMER
IDM	INDUCED DRAFT MOTOR		
IFC	INDOOR FAN CONTACTOR		
IFCB	INDOOR FAN CIRCUIT BREAKER		
IFM	INDOOR FAN MOTOR		
IGC	INTEGRATED GAS CONTROL		
IRH	INDOOR RELATIVE HUMIDITY		
JMP	JUMPER		
LA	LOW AMBIENT LOCKOUT		
LOOP PWR	CURRENT LOOP POWER		
LPS	LOW PRESSURE SWITCH		
LSM	LIMIT SWITCH (MANUAL RESET)		
LS	LIMIT SWITCH		
MGV	MAIN GAS VALVE		
OFR	OUTDOOR FAN RELAY		

Fig. 24 - 2-Stage Cooling Typical Power Diagram

C08577

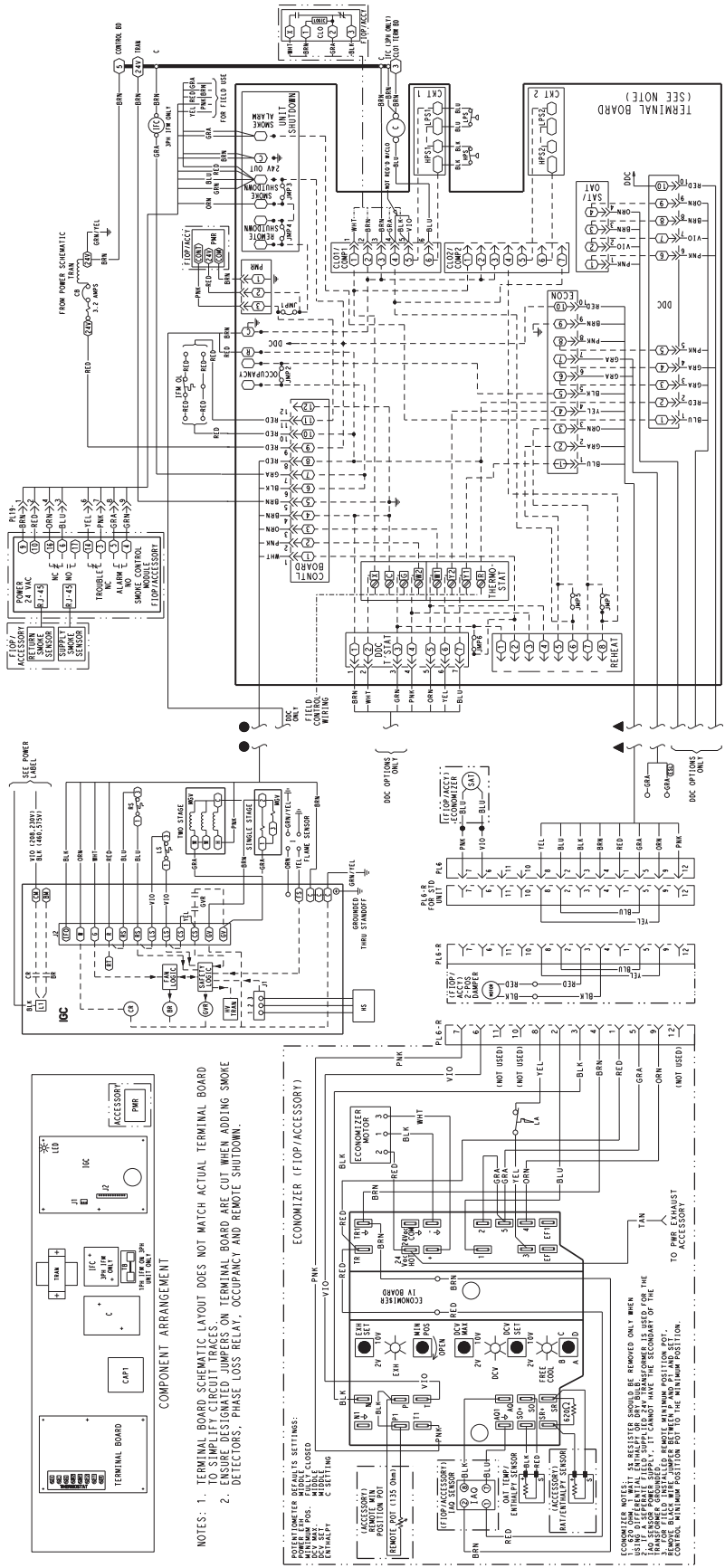

C08524

Fig. 25 - 1-Stage Typical Wiring Diagram

- NOTES: 1. TERMINAL BOARD SCHEMATIC LAYOUT DOES NOT MATCH ACTUAL TERMINAL BOARD TO SIMPLIFY CIRCUIT TRACES.
 2. INSURANCE-DESIGNED RELAYS ON TERMINAL BOARD ARE CUT WHEN ADDING SMOKE DETECTIONS, PHASE LOSS RELAY, OCCUPANCY AND REMOTE SHUTDOWN.

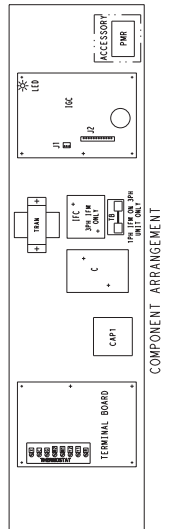

ECONOMIZER (FTOP/ACCESSORY)

POWERMETER DEFAULT SETTINGS:
 REMOTE PNT (1332 Ohm)
 REMOTE PNT (1332 Ohm)
 REMOTE PNT (1332 Ohm)
 REMOTE PNT (1332 Ohm)

ECONOMIZER NOTES:
 1. RESISTOR SHOULD BE REMOVED ONLY WHEN USING DIFFERENTIAL CIRCUITS OR DRIVERS.
 2. REMOTE PNT (1332 Ohm) IS NOT TO BE USED.
 3. REMOTE PNT (1332 Ohm) IS NOT TO BE USED.
 4. REMOTE PNT (1332 Ohm) IS NOT TO BE USED.
 5. REMOTE PNT (1332 Ohm) IS NOT TO BE USED.
 6. REMOTE PNT (1332 Ohm) IS NOT TO BE USED.
 7. REMOTE PNT (1332 Ohm) IS NOT TO BE USED.
 8. REMOTE PNT (1332 Ohm) IS NOT TO BE USED.
 9. REMOTE PNT (1332 Ohm) IS NOT TO BE USED.
 10. REMOTE PNT (1332 Ohm) IS NOT TO BE USED.

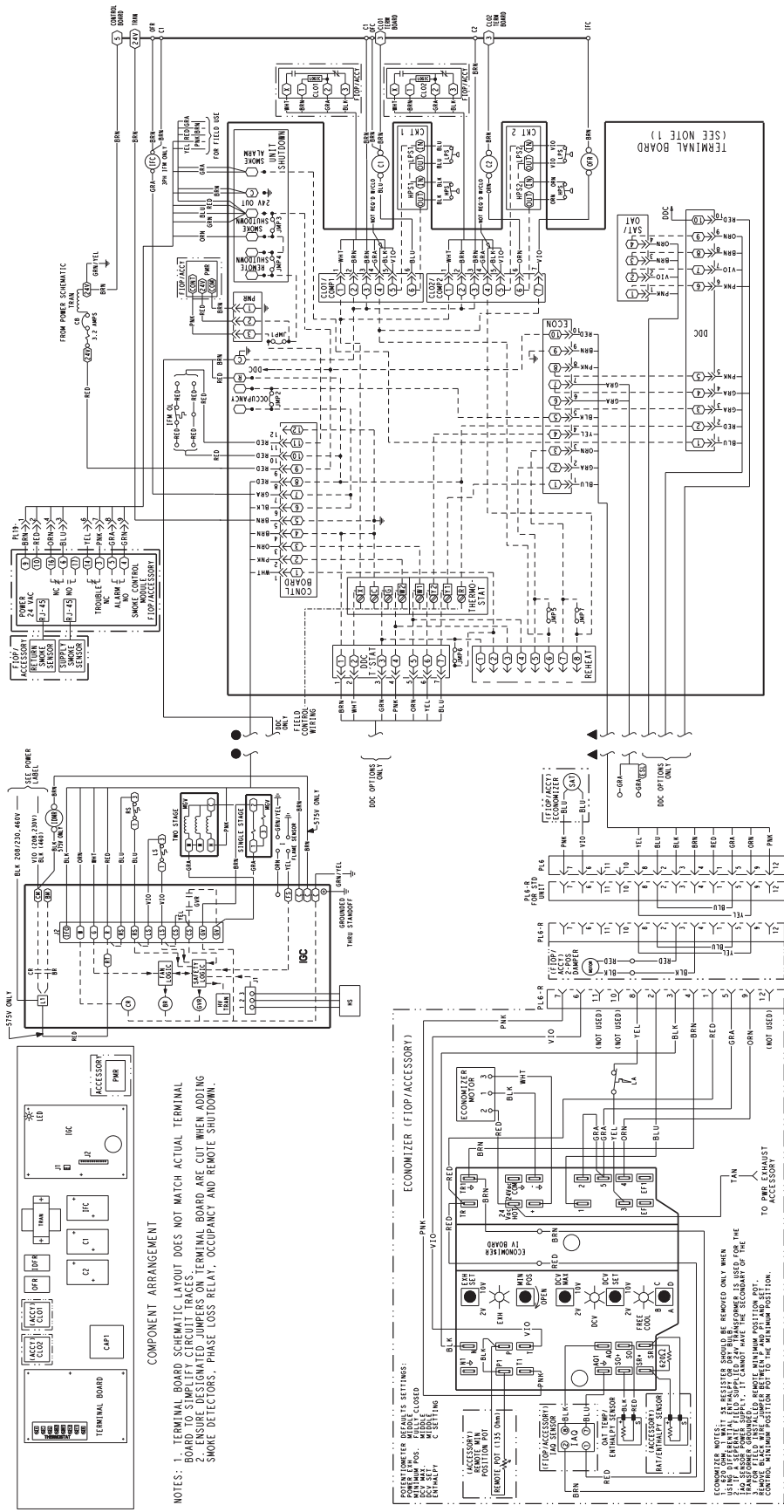

C08578

Fig. 26 - 2-Stage Typical Wiring Diagram

SEQUENCE OF OPERATION

General

The sequence below describes the sequence of operation for an electro-mechanical unit with and without a factory installed EconoMi\$er™ IV (called “economizer” in this sequence). For information regarding a direct digital controller, see the start-up, operations, and troubleshooting manual for the applicable controller.

Electro-mechanical units with no economizer

Cooling —

When the thermostat calls for cooling, terminals G and Y1 are energized. As a result, the indoor-fan contactor (IFC) and the compressor contactor (C1) are energized, causing the indoor-fan motor (IFM), compressor #1, and outdoor fan to start. If the unit has 2 stages of cooling, the thermostat will additionally energize Y2. The Y2 signal will energize compressor contactor #2 (C2), causing compressor #2 to start. Regardless of the number of stages, the outdoor-fan motor runs continuously while unit is cooling.

Heating

NOTE: WeatherMaker™ (48TC) units have either 1 or 2 stages of gas heat.

When the thermostat calls for heating, power is sent to W on the Integrated Gas Controller (IGC) board. An LED (light-emitting diode) on the IGC board turns on and remains on during normal operation. A check is made to ensure that the rollout switch and limit switch are closed. If the check was successful, the induced-draft motor is energized, and when its speed is satisfactory, as proven by the “hall effect” sensor, the ignition activation period begins. The burners will ignite within 5 seconds. If the burners do not light, there is a 22-second delay before another 5-second attempt. This sequence is repeated for 15 minutes or until the burners light. If, after the 15 minutes, the burners still have not lit, heating is locked out. To reset the control, break 24-v power to the thermostat.

When ignition occurs, the IGC board will continue to monitor the condition of the rollout switch, the limit switches, the “hall effect” sensor, as well as the flame sensor. 45 seconds after ignition occurs, assuming the unit is controlled through a room thermostat set for fan auto, the indoor-fan motor will energize (and the outdoor-air dampers will open to their minimum position). If, for some reason, the over-temperature limit opens prior to the start of the indoor fan blower, the unit will shorten the 45-second delay to 5 seconds less than the time from initiation of heat to when the limit tripped. Gas will not be interrupted to the burners and heating will continue. Once the fan-on delay has been modified, it will not change back to 45 seconds until power is reset to the control.

On units with 2 stages of heat, when additional heat is required, W2 closes and initiates power to the second stage of the main gas valve. When the thermostat is satisfied, W1 and W2 open and the gas valve closes, interrupting the flow of gas to the main burners.

If the call for W1 lasted less than 1 minute, the heating cycle will not terminate until 1 minute after W1 became active. If the unit is controlled through a room thermostat set for fan auto, the indoor-fan motor will continue to operate for an additional 45 seconds then stop. If the over-temperature limit opens after the indoor motor is stopped, but within 10 minutes of W1 becoming inactive, on the next cycle the time will be extended by 15 seconds. The maximum delay is 3 minutes. Once modified, the fan off delay will not change back to 45 seconds unless power is reset to the control. A LED indicator is provided on the IGC to monitor operation.

Electro-mechanical units with an economizer

Cooling —

When free cooling is not available, the compressors will be controlled by the zone thermostat. When free cooling is available, the outdoor-air damper is modulated by the EconoMi\$er IV control to provide a 50°F (10°C) to 55°F (13°C) mixed-air temperature into the zone. As the mixed air temperature fluctuates above 55°F (13°C) or below 50°F (10°C) dampers will be modulated (open or close) to bring the mixed-air temperature back within control. If mechanical cooling is utilized with free cooling, the outdoor-air damper will maintain its current position at the time the compressor is started. If the increase in cooling capacity causes the mixed-air temperature to drop below 45°F (7°C), then the outdoor-air damper position will be decreased to the minimum position. If the mixed-air temperature continues to fall, the outdoor-air damper will close. Control returns to normal once the mixed-air temperature rises above 48°F (9°C). The power exhaust fans will be energized and de-energized, if installed, as the outdoor-air damper opens and closes.

If field-installed accessory CO₂ sensors are connected to the EconoMi\$er IV control, a demand controlled ventilation strategy will begin to operate. As the CO₂ level in the zone increases above the CO₂ setpoint, the minimum position of the damper will be increased proportionally. As the CO₂ level decreases because of the increase in fresh air, the outdoor-air damper will be proportionally closed. For EconoMi\$er IV operation, there must be a thermostat call for the fan (G). If the unit is occupied and the fan is on, the damper will operate at minimum position. Otherwise, the damper will be closed.

When the EconoMi\$er IV control is in the occupied mode and a call for cooling exists (Y1 on the thermostat), the control will first check for indoor fan operation. If the fan is not on, then cooling will not be activated. If the fan is on, then the control will open the EconoMi\$er IV damper to the minimum position.

On the initial power to the EconoMi\$er IV control, it will take the damper up to 2 1/2 minutes before it begins to position itself. After the initial power-up, further changes in damper position can take up to 30 seconds to initiate. Damper movement from full closed to full open (or vice versa) will take between 1 1/2 and 2 1/2 minutes. If free cooling can be used as determined from the appropriate changeover command (switch, dry bulb, enthalpy curve, differential dry bulb, or differential enthalpy), then the control will modulate the dampers open to maintain the mixed-air temperature setpoint at 50°F (10°C) to 55°F (13°C). If there is a further demand for cooling (cooling second stage - Y2 is energized), then the control will bring on compressor stage 1 to maintain the mixed-air temperature setpoint. The EconoMi\$er IV damper will be open at maximum position. EconoMi\$er IV operation is limited to a single compressor.

Heating

The sequence of operation for the heating is the same as an electromechanical unit with no economizer. The only difference is how the economizer acts. The economizer will stay at the Economizer Minimum Position while the evaporator fan is operating. The outdoor-air damper is closed when the indoor fan is not operating.

Optional Humidi-MiZer Dehumidification System

Units with the factory-equipped Humidi-MiZer option are capable of providing multiple modes of improved dehumidification as a variation of the normal cooling cycle. The Humidi-MiZer option includes additional valves in the liquid line and discharge line of each refrigerant circuit, a small reheat condenser coil downstream of the evaporator, and Motormaster

variable-speed control of some or all outdoor fans. Operation of the revised refrigerant circuit for each mode is described below.

NOTE: x = refrigerant circuit A, B, or C.

Normal Cooling

Refrigerant flows from the outdoor condenser through the normally open Cooling Valve (CV.x) to the expansion device. Reheat1 Valve (RH1.x) and Reheat2 Valve (RH2.x) are closed.

Reheat1 (Subcooling Mode) - 48TC04-07

This mode increases latent cooling and decreases sensible cooling compared to normal cooling. Refrigerant flows from the outdoor condenser, through the normally open Reheat1 Valve (RH1.x), and through the reheat condenser coil to the expansion device. Cooling Valve (CV.x) and Reheat2 Valve (RH2.x) are closed.

Reheat2 (Hot Gas Reheat Mode) -48TC04-07

This mode provides maximum latent cooling with little to no sensible capacity. This mode can operate to provide dehumidification when there is no cooling demand. Like Reheat1 mode, refrigerant flows from the outdoor condenser, through the normally open Reheat1 Valve (RH1.x), and through the reheat condenser coil to the expansion device. The Cooling Valve (CV.x) is closed. Reheat2 Valve (RH2.x) is open which provides some compressor discharge gas to the reheat condenser to further increase the reheat of the evaporator airstream.

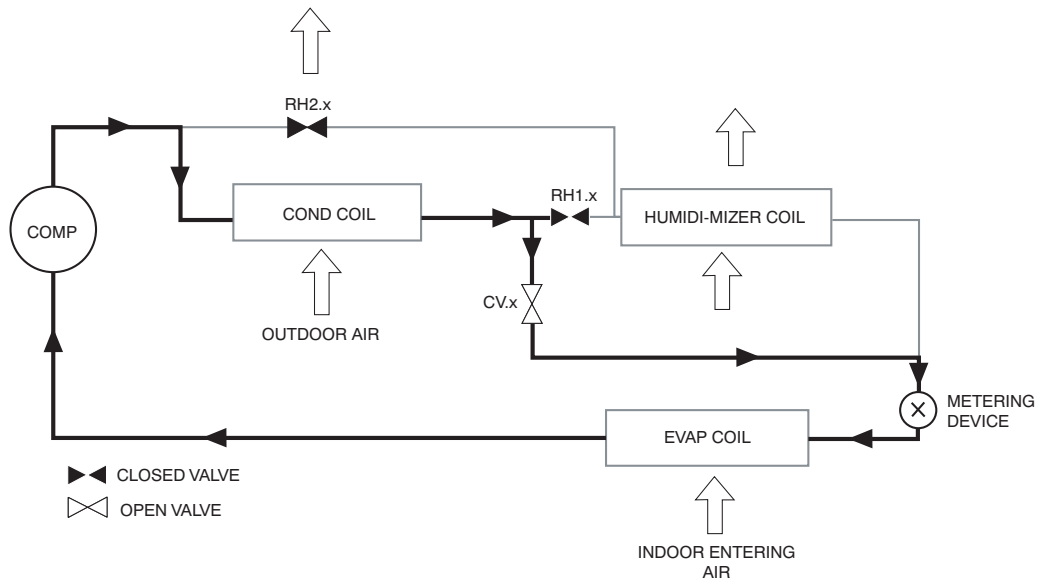

Normal Cooling Mode - Humidi-MiZer System (48TC04-07)

C07119

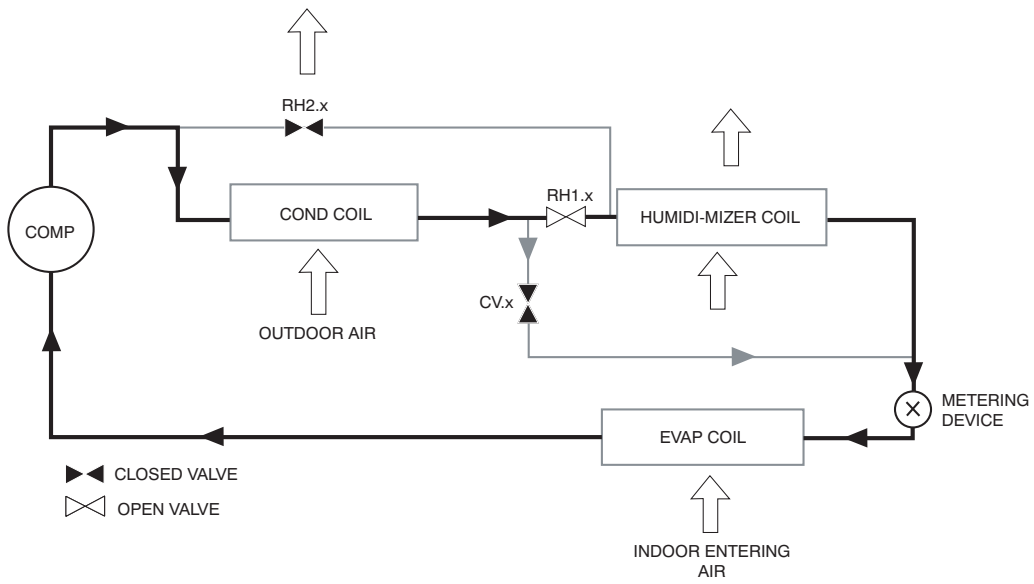

C07120

48TC

Subcooling Mode (Reheat 1) - Humidi-MiZer System (48TC04-07)

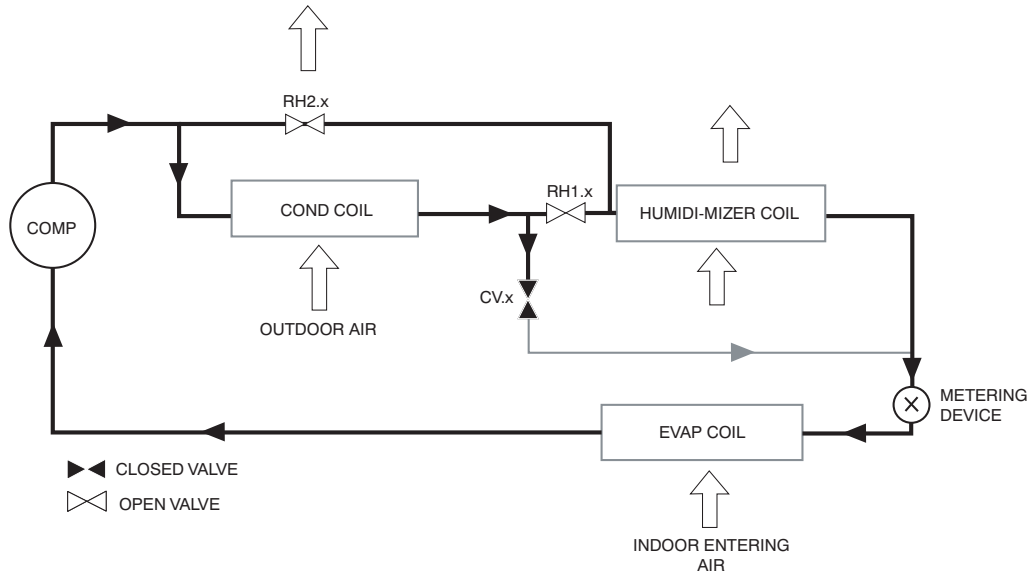

C07121

Hot Gas Reheat Mode (Reheat2) - Humidi-MiZer System (48TC04-07)

GUIDE SPECIFICATIONS - 48TC**04-14

Note about this specification:

Carrier wrote this specification in the 2004 version of the “Masterformat” as published by the Construction Specification Institute. Please feel free to copy this specification directly into your building spec.

Gas Heat/Electric Cooling Packaged Rooftop

HVAC Guide Specifications

Size Range: 3 to 12.5 Nominal Tons



This product has been designed and manufactured to meet Energy Star® criteria for energy efficiency. However, proper refrigerant charge and proper air flow are critical to achieve rated capacity and efficiency. Installation of this product should follow all manufacturer's refrigerant charging and air flow instructions. **Failure to confirm proper charge and air flow may reduce energy efficiency and shorten equipment life.**

48TC

<u>Section</u>	<u>Description</u>
----------------	--------------------

23 06 80	Schedules for Decentralized HVAC Equipment
-----------------	---

- | | |
|----------------|---|
| 23 06 80.13 | Decentralized Unitary HVAC Equipment Schedule |
| 23 06 80.13.A. | Rooftop unit schedule |
| 1. | Schedule is per the project specification requirements. |

23 07 16	HVAC Equipment Insulation
-----------------	----------------------------------

- | | |
|----------------|---|
| 23 07 16.13 | Decentralized, Rooftop Units: |
| 23 07 16.13.A. | Evaporator fan compartment: |
| 1. | Interior cabinet surfaces shall be insulated with a minimum 1/2-in. thick, minimum 1 1/2 lb density, flexible fiberglass insulation bonded with a phenolic binder, neoprene coated on the air side. |
| 2. | Insulation and adhesive shall meet NFPA 90A requirements for flame spread and smoke generation. |
| 23 07 16.13.B. | Gas heat compartment: |
| 1. | Aluminum foil-faced fiberglass insulation shall be used. |
| 2. | Insulation and adhesive shall meet NFPA 90A requirements for flame spread and smoke generation. |

23 09 13	Instrumentation and Control Devices for HVAC
-----------------	---

- | | |
|----------------|---|
| 23 09 13.23 | Sensors and Transmitters |
| 23 09 13.23.A. | Thermostats |
| 1. | Thermostat must |
| a. | energize both “W” and “G” when calling for heat. |
| b. | have capability to energize 2 different stages of cooling, and 2 different stages of heating. |
| c. | include capability for occupancy scheduling. |

23 09 23	Direct-digital Control system for HVAC
-----------------	---

- | | |
|----------------|--|
| 23 09 23.13 | Decentralized, Rooftop Units: |
| 23 09 23.13.A. | PremierLink™ controller |
| 1. | Shall be ASHRAE 62-2001 compliant. |
| 2. | Shall accept 18-32 VAC input power. |
| 3. | Shall have an operating temperature range from -40°F (-40°C) to 158°F (70°C), 10% - 95% RH (non-condensing). |
| 4. | Shall include an integrated economizer controller to support an economizer with 4 to 20 mA actuator input and no microprocessor controller. |
| 5. | Controller shall accept the following inputs: space temperature, setpoint adjustment, outdoor air temperature, indoor air quality, outdoor air quality, indoor relative humidity, compressor lock-out, fire shutdown, enthalpy, fan status, remote time clock/door switch. |

6. Shall accept a CO₂ sensor in the conditioned space, and be Demand Control Ventilation (DCV) ready.
 7. Shall provide the following outputs: economizer, fan, cooling stage 1, cooling stage 2, heat stage 1, heat stage 2, heat stage 3/ exhaust/ reversing valve/ dehumidify/ occupied.
 8. Unit shall provide surge protection for the controller through a circuit breaker.
 9. Shall be Internet capable, and communicate at a Baud rate of 38.4K or faster
 10. Shall have an LED display independently showing the status of activity on the communication bus, and processor operation.
 11. Shall include an EIA-485 protocol communication port, an access port for connection of either a computer or a Carrier technician tool, an EIA-485 port for network communication to intelligent space sensors and displays, and a port to connect an optional LonWorks plug-in communications card.
 12. Shall have built-in Carrier Comfort Network™ (CCN) protocol, and be compatible with other CCN devices, including ComfortLink™ and ComfortVIEW™ controllers.
 13. Shall have built-in support for Carrier technician tool.
 14. Software upgrades will be accomplished by local download. Software upgrades through chip replacements are not allowed.
 15. Shall be shock resistant in all planes to 5G peak, 11ms during operation, and 100G peak, 11ms during storage.
 16. Shall be vibration resistant in all planes to 1.5G @ 20-300 Hz.
 17. Shall support a bus length of 4000 ft (1219m) max, 60 devices per 1000 ft (305m) section, and 1 RS-485 repeater per 1000 ft (305m) sections.
- 23 09 23.13.B. RTU-MP - Open protocol, direct digital controller:
1. Shall be ASHRAE 62-2001 compliant.
 2. Shall accept 18-30VAC, 50-60Hz, and consumer 15VA or less power.
 3. Shall have an operating temperature range from -40°F (-40°C) to 130°F (54°C), 10% - 90% RH (non-condensing).
 4. Shall include built-in protocol for BACNET (MS/TP and PTP modes), Modbus (RTU and ASCII), Johnson N2 and LonWorks. LonWorks Echelon processor required for all Lon applications shall be contained in separate communication board.
 5. Shall allow access of up to 62 network variables (SNVT). Shall be compatible with all open controllers
 6. Baud rate Controller shall be selectable using a dipswitch.
 7. Shall have an LED display independently showing the status of serial communication, running, errors, power, all digital outputs, and all analog inputs.
 8. Shall accept the following inputs: space temperature, setpoint adjustment, outdoor air temperature, indoor air quality, outdoor air quality, compressor lock-out, fire shutdown, enthalpy switch, and fan status/filter status/ humidity/ remote occupancy.
 9. Shall provide the following outputs: economizer, fan, cooling stage 1, cooling stage 2, heat stage 1, heat stage 2, heat stage 3/ exhaust/ reversing valve.
 10. Shall have built-in surge protection circuitry through solid state polyswitches. Polyswitches shall be used on incoming power and network connections. Polyswitches will return to normal when the “trip” condition clears.
 11. Shall have a battery back-up capable of a minimum of 10,000 hours of data and time clock retention during power outages.
 12. Shall have built-in support for Carrier technician tool.
 13. Shall include an EIA-485 protocol communication port, an access port for connection of either a computer or a Carrier technician tool, an EIA-485 port for network communication to intelligent space sensors and displays, and a port to connect an optional LonWorks communications card.
 14. Software upgrades will be accomplished by either local or remote download. No software upgrades through chip replacements are allowed.

23 09 33 Electric and Electronic Control System for HVAC

23 09 33.13 Decentralized, Rooftop Units:

23 09 33.13.A. General:

1. Shall be complete with self-contained low-voltage control circuit protected by a resettable circuit breaker on the 24-v transformer side. Transformer shall have 75VA capability.
2. Shall utilize color-coded wiring.
3. Shall include a central control terminal board to conveniently and safely provide connection points for vital control functions such as: smoke detectors, phase monitor, gas controller, economizer, thermostat, DDC control options, and low and high pressure switches.

4. The heat exchanger shall be controlled by an integrated gas controller (IGC) microprocessor. See heat exchanger section of this specification.
5. Unit shall include a minimum of one 8-pin screw terminal connection board for connection of control wiring.

23 09 33.23.B. Safeties:

1. Compressor over-temperature, over-current. High internal pressure differential.
2. Low-pressure switch.
 - a. Units with 2 compressors shall have different sized connectors for the circuit 1 and circuit 2 low and high pressure switches. They shall physically prevent the cross-wiring of the safety switches between circuits 1 and 2.
 - b. Low pressure switch shall use different color wire than the high pressure switch. The purpose is to assist the installer and service technician to correctly wire and or troubleshoot the rooftop unit.
3. High-pressure switch.
 - a. Units with 2 compressors shall have different sized connectors for the circuit 1 and circuit 2 low and high pressure switches. They shall physically prevent the cross-wiring of the safety switches between circuits 1 and 2.
 - b. High pressure switch shall use different color wire than the low pressure switch. The purpose is to assist the installer and service technician to correctly wire and or troubleshoot the rooftop unit.
4. Automatic reset, motor thermal overload protector.
5. Heating section shall be provided with the following minimum protections:
 - a. High-temperature limit switches.
 - b. Induced draft motor speed sensor.
 - c. Flame rollout switch.
 - d. Flame proving controls.

23 09 93 Sequence of Operations for HVAC Controls

23 09 93.13 Decentralized, Rooftop Units:

23 09 93.13 INSERT SEQUENCE OF OPERATION

23 40 13 Panel Air Filters

23 40 13.13 Decentralized, Rooftop Units:

23 40 13.13.A. Standard filter section

1. Shall consist of factory-installed, low velocity, disposable 2-in. thick fiberglass filters of commercially available sizes.
2. Unit shall use only one filter size. Multiple sizes are not acceptable.
3. Filters shall be accessible through an access panel with “no-tool” removal as described in the unit cabinet section of this specification (23 81 19.13.H).

23 81 19 Self-Contained Air Conditioners

23 81 19.13 Small-Capacity Self-Contained Air Conditioners (48TC**04-14)

23 81 19.13.A. General

1. Outdoor, rooftop mounted, electrically controlled, heating and cooling unit utilizing a fully hermetic scroll compressor(s) for cooling duty and gas combustion for heating duty.
2. Factory assembled, single-piece heating and cooling rooftop unit. Contained within the unit enclosure shall be all factory wiring, piping, controls, and special features required prior to field start-up.
3. Unit shall use environmentally sound, Puron® refrigerant.
4. Unit shall be installed in accordance with the manufacturer’s instructions.
5. Unit must be selected and installed in compliance with local, state, and federal codes.

23 81 19.13.B. Quality Assurance

1. Unit meets ASHRAE 90.1-2004 minimum efficiency requirements.
2. 3 phase units are Energy Star certified.
3. Unit shall be rated in accordance with AHRI Standards 210 and 360.
4. Unit shall be designed to conform to ASHRAE 15, 2001.
5. Unit shall be UL-tested and certified in accordance with ANSI Z21.47 Standards and UL-listed and certified under Canadian standards as a total package for safety requirements.
6. Insulation and adhesive shall meet NFPA 90A requirements for flame spread and smoke generation.
7. Unit casing shall be capable of withstanding 500-hour salt spray exposure per ASTM B117 (scribed specimen).
8. Unit casing shall be capable of withstanding Federal Test Method Standard No. 141 (Method 6061) 5000-hour salt spray.

9. Unit shall be designed in accordance with ISO 9001:2000, and shall be manufactured in a facility registered by ISO 9001:2000.
 10. Roof curb shall be designed to conform to NRCA Standards.
 11. Unit shall be subjected to a completely automated run test on the assembly line. The data for each unit will be stored at the factory, and must be available upon request.
 12. Unit shall be designed in accordance with UL Standard 1995, including tested to withstand rain.
 13. Unit shall be constructed to prevent intrusion of snow and tested to prevent snow intrusion into the control box up to 40 mph.
 14. Unit shake tested to assurance level 1, ASTM D4169 to ensure shipping reliability.
- 23 81 19.13.C. Delivery, Storage, and Handling
1. Unit shall be stored and handled per manufacturer's recommendations.
 2. Lifted by crane requires either shipping top panel or spreader bars.
 3. Unit shall only be stored or positioned in the upright position.
- 23 81 19.13.E. Project Conditions
1. As specified in the contract.
- 23 81 19.13.F. Operating Characteristics
1. Unit shall be capable of starting and running at 115°F (46°C) ambient outdoor temperature, meeting maximum load criteria of AHRI Standard 210/240 or 360 at ± 10% voltage.
 2. Compressor with standard controls shall be capable of operation down to 40°F (4°C), ambient outdoor temperatures. Accessory winter start kit is necessary if mechanically cooling at ambient temperatures below 40°F (4°C).
 3. Unit shall discharge supply air vertically or horizontally as shown on contract drawings.
 4. Unit shall be factory configured for vertical supply & return configurations.
 5. Unit shall be field convertible from vertical to horizontal configuration without the use of special conversion kits.
 6. Unit shall be capable of mixed operation: vertical supply with horizontal return or horizontal supply with vertical return.
- 23 81 19.13.G. Electrical Requirements
1. Main power supply voltage, phase, and frequency must match those required by the manufacturer.
- 23 81 19.13.H. Unit Cabinet
1. Unit cabinet shall be constructed of galvanized steel, and shall be bonderized and coated with a pre-painted baked enamel finish on all externally exposed surfaces.
 2. Unit cabinet exterior paint shall be: film thickness, (dry) 0.003 inches minimum, gloss (per ASTM D523, 60°F / 16°C): 60, Hardness: H-2H Pencil hardness.
 3. Evaporator fan compartment interior cabinet insulation shall conform to AHRI Standards 210 or 360 minimum exterior sweat criteria. Interior surfaces shall be insulated with a minimum 1/2-in. thick, 1 lb density, flexible fiberglass insulation, neoprene coated on the air side. Aluminum foil-faced fiberglass insulation shall be used in the gas heat compartment.
 4. Base of unit shall have a minimum of four locations for thru-the-base gas and electrical connections (factory installed or field installed), standard.
 5. Base Rail
 - a. Unit shall have base rails on a minimum of 2 sides.
 - b. Holes shall be provided in the base rails for rigging shackles to facilitate maneuvering and overhead rigging.
 - c. Holes shall be provided in the base rail for moving the rooftop by fork truck.
 - d. Base rail shall be a minimum of 16 gauge thickness.
 6. Condensate pan and connections:
 - a. Shall be a sloped condensate drain pan made of a non-corrosive material.
 - b. Shall comply with ASHRAE Standard 62.
 - c. Shall use a 3/4" -14 NPT drain connection, possible either through the bottom or side of the drain pan. Connection shall be made per manufacturer's recommendations.
 7. Top panel:
 - a. Shall be a single piece top panel on 04 thru 12 sizes, two piece on 14 size.
 8. Gas Connections:
 - a. All gas piping connecting to unit gas valve shall enter the unit cabinet at a single location on side of unit (horizontal plane).

- b. Thru-the-base capability
 - (1.) Standard unit shall have a thru-the-base gas-line location using a raised, embossed portion of the unit basepan.
 - (2.) Optional, factory-approved, water-tight connection method must be used for thru-the-base gas connections.
 - (3.) No basepan penetration, other than those authorized by the manufacturer, is permitted.

9. Electrical Connections

- a. All unit power wiring shall enter unit cabinet at a single, factory-prepared, knockout location.
- b. Thru-the-base capability.
 - (1.) Standard unit shall have a thru-the-base electrical location(s) using a raised, embossed portion of the unit basepan.
 - (2.) Optional, factory-approved, water-tight connection method must be used for thru-the-base electrical connections.
 - (3.) No basepan penetration, other than those authorized by the manufacturer, is permitted.

10. Component access panels (standard)

- a. Cabinet panels shall be easily removable for servicing.
- b. Unit shall have one factory installed, tool-less, removable, filter access panel.
- c. Panels covering control box, indoor fan, indoor fan motor, gas components (where applicable), and compressors shall have a molded composite handles.
- d. Handles shall be UV modified, composite. They shall be permanently attached, and recessed into the panel.
- e. Screws on the vertical portion of all removable access panel shall engage into heat resistant, molded composite collars.
- f. Collars shall be removable and easily replaceable using manufacturer recommended parts.

23 81 19.13.I. Gas Heat

1. General

- a. Heat exchanger shall be an induced draft design. Positive pressure heat exchanger designs shall not be allowed.
- b. Shall incorporate a direct-spark ignition system and redundant main gas valve.
- c. Gas supply pressure at the inlet to the rooftop unit gas valve must match that required by the manufacturer.

2. The heat exchanger shall be controlled by an integrated gas controller (IGC) microprocessor.

- a. IGC board shall notify users of fault using an LED (light-emitting diode).
- b. The LED shall be visible without removing the control box access panel.
- c. IGC board shall contain algorithms that modify evaporator-fan operation to prevent future cycling on high temperature limit switch.
- d. Unit shall be equipped with anti-cycle protection with one short cycle on unit flame rollout switch or 4 continuous short cycles on the high temperature limit switch. Fault indication shall be made using an LED.

3. Standard Heat Exchanger construction

- a. Heat exchanger shall be of the tubular-section type constructed of a minimum of 20-gauge steel coated with a nominal 1.2 mil aluminum-silicone alloy for corrosion resistance.
- b. Burners shall be of the in-shot type constructed of aluminum-coated steel.
- c. Burners shall incorporate orifices for rated heat output up to 2000 ft (610m) elevation. Additional accessory kits may be required for applications above 2000 ft (610m) elevation, depending on local gas supply conditions.
- d. Each heat exchanger tube shall contain multiple dimples for increased heating effectiveness.

4. Optional Stainless Steel Heat Exchanger construction

- a. Use energy saving, direct-spark ignition system.
- b. Use a redundant main gas valve.
- c. Burners shall be of the in-shot type constructed of aluminum-coated steel.
- d. All gas piping shall enter the unit cabinet at a single location on side of unit (horizontal plane).
- e. The optional stainless steel heat exchanger shall be of the tubular-section type, constructed of a minimum of 20-gauge type 409 stainless steel.
- f. Type 409 stainless steel shall be used in heat exchanger tubes and vestibule plate.
- g. Complete stainless steel heat exchanger allows for greater application flexibility.

5. Optional Low NO_x Heat Exchanger construction
 - a. Low NO_x reduction shall be provided to reduce nitrous oxide emissions to meet California's Air Quality Management District (SCAQMD) low-NO_x emissions requirement of 40 nanograms per joule or less.
 - b. Primary tubes and vestibule plates on low NO_x units shall be 409 stainless steel. Other components shall be aluminized steel.
6. Induced draft combustion motor and blower
 - a. Shall be a direct-drive, single inlet, forward-curved centrifugal type.
 - b. Shall be made from steel with a corrosion-resistant finish.
 - c. Shall have permanently lubricated sealed bearings.
 - d. Shall have inherent thermal overload protection.
 - e. Shall have an automatic reset feature.

23 81 19.13.J. Coils

1. Standard Aluminum/Copper Coils: (04 -12 single compressor/single stage cooling models only)
 - a. Standard evaporator and condenser coils shall have aluminum lanced plate fins mechanically bonded to seamless internally grooved copper tubes with all joints brazed.
 - b. Evaporator coils shall be leak tested to 150 psig, pressure tested to 450 psig, and qualified to UL 1995 burst test at 1775 psig.
 - c. Condenser coils shall be leak tested to 150 psig, pressure tested to 650 psig, and qualified to UL 1995 burst test at 1980 psig.
2. Optional Pre-coated aluminum-fin condenser coils: (04 -12 single compressor/single stage cooling models only)
 - a. Shall have a durable epoxy-phenolic coating to provide protection in mildly corrosive coastal environments.
 - b. Coating shall be applied to the aluminum fin stock prior to the fin stamping process to create an inert barrier between the aluminum fin and copper tube.
 - c. Epoxy-phenolic barrier shall minimize galvanic action between dissimilar metals.
3. Optional Copper-fin evaporator and condenser coils: (04 -12 single compressor/single stage cooling models only)
 - a. Shall be constructed of copper fins mechanically bonded to copper tubes and copper tube sheets.
 - b. Galvanized steel tube sheets shall not be acceptable.
 - c. A polymer strip shall prevent coil assembly from contacting the sheet metal coil pan to minimize potential for galvanic corrosion between coil and pan.
4. Optional E-coated aluminum-fin evaporator and condenser coils: (04 -12 single compressor/single stage cooling models only)
 - a. Shall have a flexible epoxy polymer coating uniformly applied to all coil surface areas without material bridging between fins.
 - b. Coating process shall ensure complete coil encapsulation of tubes, fins and headers.
 - c. Color shall be high gloss black with gloss per ASTM D523-89.
 - d. Uniform dry film thickness from 0.8 to 1.2 mil on all surface areas including fin edges.
 - e. Superior hardness characteristics of 2H per ASTM D3363-92A and cross-hatch adhesion of 4B-5B per ASTM D3359-93.
 - f. Impact resistance shall be up to 160 in.-lb (ASTM D2794-93).
 - g. Humidity and water immersion resistance shall be up to minimum 1000 and 250 hours respectively (ASTM D2247-92 and ASTM D870-92).
 - h. Corrosion durability shall be confirmed through testing to be no less than 1000 hours salt spray per ASTM B117-90.
5. Standard Coils: (08 -14 two compressor/two stage cooling models only)
 - a. Standard evaporator coils shall have aluminum lanced plate fins mechanically bonded to seamless internally grooved copper tubes with all joints brazed.
 - b. Evaporator coils shall be leak tested to 150 psig, pressure tested to 450 psig, and qualified to UL 1995 burst test at 1775 psig.
 - c. Standard condenser coils shall have all aluminum NOVATION™ Heat Exchanger Technology design consisting of aluminum multi port flat tube design and aluminum fin. Coils shall be a furnace brazed design and contain epoxy lined shrink wrap on all aluminum to copper connections.
 - d. Condenser coils shall be leak tested to 150 psig, pressure tested to 650 psig, and qualified to UL 1995 burst test at 1980 psig.
6. Optional E-coated aluminum-fin, aluminum tube condenser coils:
 - a. Shall have a flexible epoxy polymer coating uniformly applied to all coil external surface areas without material bridging between fins or louvers.

- b. Coating process shall ensure complete coil encapsulation, including all exposed fin edges.
- c. E-coat thickness of 0.8 to 1.2 mil with top coat having a uniform dry film thickness from 1.0 to 2.0 mil on all external coil surface areas, including fin edges, shall be provided.
- d. Shall have superior hardness characteristics of 2H per ASTM D3363-00 and cross-hatch adhesion of 4B-5B per ASTM D3359-02.
- e. Shall have superior impact resistance with no cracking, chipping or peeling per NSF/ANSI 51-2002 Method 10.2.

23 81 19.13.K. Refrigerant Components

1. Refrigerant circuit shall include the following control, safety, and maintenance features:
 - a. Fixed orifice metering system shall prevent mal-distribution of two-phase refrigerant by including multiple fixed orifice devices in each refrigeration circuit. Each orifice is to be optimized to the coil circuit it serves.
 - b. Refrigerant filter drier - Solid core design.
 - c. Service gauge connections on suction and discharge lines.
 - d. Pressure gauge access through a specially designed access port in the top panel of the unit.
2. There shall be gauge line access port in the skin of the rooftop, covered by a black, removable plug.
 - a. The plug shall be easy to remove and replace.
 - b. When the plug is removed, the gauge access port shall enable maintenance personnel to route their pressure gauge lines.
 - c. This gauge access port shall facilitate correct and accurate condenser pressure readings by enabling the reading with the compressor access panel on.
 - d. The plug shall be made of a leak proof, UV-resistant, composite material.
3. Compressors
 - a. Unit shall use fully hermetic, scroll compressor for each independent refrigeration circuit.
 - b. Models shall be available with single compressor/single stage cooling designs on 04 – 12 models, plus additional 2 compressor/2 stage cooling models from 08 – 14 sizes with NOVATION™ condenser coils.
 - c. Compressor motors shall be cooled by refrigerant gas passing through motor windings.
 - d. Compressors shall be internally protected from high discharge temperature conditions.
 - e. Compressors shall be protected from an over-temperature and over-amperage conditions by an internal, motor overload device.
 - f. Compressor shall be factory mounted on rubber grommets.
 - g. Compressor motors shall have internal line break thermal, current overload and high pressure differential protection.
 - h. Crankcase heaters shall not be required for normal operating range, unless provided by the factory.

23 81 19.13.L. Filter Section

1. Filters access is specified in the unit cabinet section of this specification.
2. Filters shall be held in place by a pivoting filter tray, facilitating easy removal and installation.
3. Shall consist of factory-installed, low velocity, throw-away 2-in. thick fiberglass filters.
4. Filters shall be standard, commercially available sizes.
5. Only one size filter per unit is allowed.

23 81 19.13.M. Evaporator Fan and Motor

1. Evaporator fan motor:
 - a. Shall have permanently lubricated bearings.
 - b. Shall have inherent automatic-reset thermal overload protection or circuit breaker.
 - c. Shall have a maximum continuous bhp rating for continuous duty operation; no safety factors above that rating shall be required.
2. Belt-driven Evaporator Fan:
 - a. Belt drive shall include an adjustable-pitch motor pulley.
 - b. Shall use sealed, permanently lubricated ball-bearing type.
 - c. Blower fan shall be double-inlet type with forward-curved blades.
 - d. Shall be constructed from steel with a corrosion resistant finish and dynamically balanced.

23 81 19.13.N. Condenser Fans and Motors

1. Condenser fan motors:
 - a. Shall be a totally enclosed motor.
 - b. Shall use permanently lubricated bearings.

- c. Shall have inherent thermal overload protection with an automatic reset feature.
- d. Shall use a shaft-down design on 04 to 12 models and shaft-up on 14 size with rain shield.

2. Condenser Fans:

- a. Shall be a direct-driven propeller type fan.
- b. Shall have aluminum blades riveted to corrosion-resistant steel spiders and shall be dynamically balanced.

23 81 19.13.O. Special Features Options and Accessories

1. Integrated Economizers:

- a. Integrated, gear-driven parallel modulating blade design type capable of simultaneous economizer and compressor operation.
- b. Independent modules for vertical or horizontal return configurations shall be available. Vertical return modules shall be available as a factory installed option.
- c. Damper blades shall be galvanized steel with composite gears. Plastic or composite blades on intake or return shall not be acceptable.
- d. Shall include all hardware and controls to provide free cooling with outdoor air when temperature and/or humidity are below setpoints.
- e. Shall be equipped with gear driven dampers for both the outdoor ventilation air and the return air for positive air stream control.
- f. Shall be equipped with low-leakage dampers, not to exceed 2% leakage at 1 in. wg pressure differential.
- g. Shall be capable of introducing up to 100% outdoor air.
- h. Shall be equipped with a barometric relief damper capable of relieving up to 100% return air.
- i. Shall be designed to close damper(s) during loss-of-power situations with spring return built into motor.
- j. Dry bulb outdoor-air temperature sensor shall be provided as standard. Outdoor air sensor setpoint shall be adjustable and shall range from 40 to 100°F / 4 to 38°C. Additional sensor options shall be available as accessories.
- k. The economizer controller shall also provide control of an accessory power exhaust unit. function. Factory set at 100%, with a range of 0% to 100%.
- l. The economizer shall maintain minimum airflow into the building during occupied period and provide design ventilation rate for full occupancy. A remote potentiometer may be used to override the damper setpoint.
- m. Dampers shall be completely closed when the unit is in the unoccupied mode.
- n. Economizer controller shall accept a 2-10Vdc CO₂ sensor input for IAQ/DCV control. In this mode, dampers shall modulate the outdoor-air damper to provide ventilation based on the sensor input.
- o. Compressor lockout sensor shall open at 35°F (2°C) and close closes at 50°F (10°C).
- p. Actuator shall be direct coupled to economizer gear. No linkage arms or control rods shall be acceptable.
- q. Economizer controller shall provide indications when in free cooling mode, in the DCV mode, or the exhaust fan contact is closed.

2. Two-Position Damper

- a. Damper shall be a Two-Position Damper. Damper travel shall be from the full closed position to the field adjustable %-open setpoint.
- b. Damper shall include adjustable damper travel from 25% to 100% (full open).
- c. Damper shall include single or dual blade, gear driven dampers and actuator motor.
- d. Actuator shall be direct coupled to damper gear. No linkage arms or control rods shall be acceptable.
- e. Damper will admit up to 100% outdoor air for applicable rooftop units.
- f. Damper shall close upon indoor (evaporator) fan shutoff and/or loss of power.
- g. The damper actuator shall plug into the rooftop unit's wiring harness plug. No hard wiring shall be required.
- h. Outside air hood shall include aluminum water entrainment filter.

3. Manual damper

- a. Manual damper package shall consist of damper, air inlet screen, and rain hood which can be preset to admit up to 25 or 50% outdoor air for year round ventilation.

4. Humidi-MiZer Adaptive Dehumidification System:

- a. The Humidi-MiZer dehumidification system shall be factory-installed in the 50TC04-07 rooftop units, and shall provide greater dehumidification of the occupied space by two modes of dehumidification operations beside its normal design cooling mode:
 - (1.) Subcooling mode further subcools the hot liquid refrigerant leaving the condenser coil when both temperature and humidity in the space are not satisfied.

- (2.) Hot gas reheat mode shall mix a portion of the hot gas from the discharge of the compressor with the hot liquid refrigerant leaving the condenser coil to create a two-phase heat transfer in the system, resulting in a neutral leaving- air temperature when only humidity in the space is not satisfied.
5. Head Pressure Control Package
 - a. Controller shall control coil head pressure by condenser-fan speed modulation or condenser-fan cycling and wind baffles.
 - b. Shall consist of solid-state control and condenser-coil temperature sensor to maintain condensing temperature between 90°F (32°C) and 110°F (43°C) at outdoor ambient temperatures down to -20°F (-29°C).
 6. Propane Conversion Kit
 - a. Package shall contain all the necessary hardware and instructions to convert a standard natural gas unit for use with liquefied propane, up to 2000 ft (610m) elevation.
 - b. Additional accessory kits may be required for applications above 2000 ft (610m) elevation.
 7. Flue Shield
 - a. Flue shield shall provide protection from the hot sides of the gas flue hood.
 8. Condenser Coil Hail Guard Assembly
 - a. Shall protect against damage from hail.
 - b. Shall be either hood style or louvered.
 9. Unit-Mounted, Non-Fused Disconnect Switch:
 - a. Switch shall be factory-installed, internally mounted.
 - b. National Electric Code (NEC) and UL approved non-fused switch shall provide unit power shutoff.
 - c. Shall be accessible from outside the unit.
 - d. Shall provide local shutdown and lockout capability.
 10. Convenience Outlet:
 - a. Powered convenience outlet.
 - (1.) Outlet shall be powered from main line power to the rooftop unit.
 - (2.) Outlet shall be powered from line side or load side of disconnect by installing contractor, as required by code. If outlet is powered from load side of disconnect, unit electrical ratings shall be UL certified and rated for additional outlet amperage.
 - (3.) Outlet shall be factory-installed and internally mounted with easily accessible 115-v female receptacle.
 - (4.) Outlet shall include 15 amp GFI receptacles with independent fuse protection.
 - (5.) Voltage required to operate convenience outlet shall be provided by a factory-installed step-down transformer.
 - (6.) Outlet shall be accessible from outside the unit.
 - (7.) Outlet shall include a field-installed “Wet in Use” cover.
 - b. Non-Powered convenience outlet.
 - (1.) Outlet shall be powered from a separate 115/120v power source.
 - (2.) A transformer shall not be included.
 - (3.) Outlet shall be factory-installed and internally mounted with easily accessible 115-v female receptacle.
 - (4.) Outlet shall include 15 amp GFI receptacles with independent fuse protection.
 - (5.) Outlet shall be accessible from outside the unit.
 - (6.) Outlet shall include a field-installed “Wet in Use” cover.
 11. Flue Discharge Deflector:
 - a. Flue discharge deflector shall direct unit exhaust vertically instead of horizontally.
 - b. Deflector shall be defined as a “natural draft” device by the National Fuel and Gas (NFG) code.
 12. Thru-the-Base Connectors:
 - a. Kits shall provide connectors to permit gas and electrical connections to be brought to the unit through the unit basepan.
 - b. Minimum of four connection locations per unit.
 13. Propeller Power Exhaust:
 - a. Power exhaust shall be used in conjunction with an integrated economizer.
 - b. Independent modules for vertical or horizontal return configurations shall be available.
 - c. Horizontal power exhaust is shall be mounted in return ductwork.
 - d. Power exhaust shall be controlled by economizer controller operation. Exhaust fans shall be energized when dampers open past the 0-100% adjustable setpoint on the economizer control.

14. Roof Curbs (Vertical):
 - a. Full perimeter roof curb with exhaust capability providing separate air streams for energy recovery from the exhaust air without supply air contamination.
 - b. Formed galvanized steel with wood nailer strip and shall be capable of supporting entire unit weight.
 - c. Permits installation and securing of ductwork to curb prior to mounting unit on the curb.
15. High Altitude Gas Conversion Kit:
 - a. Package shall contain all the necessary hardware and instructions to convert a standard natural gas unit to operate from 2000-7000 ft (610 to 2134m) elevation with natural gas or from 0-7000 ft (90-2134m) elevation with liquefied propane.
16. Outdoor Air Enthalpy Sensor:
 - a. The outdoor air enthalpy sensor shall be used to provide single enthalpy control. When used in conjunction with a return air enthalpy sensor, the unit will provide differential enthalpy control. The sensor allows the unit to determine if outside air is suitable for free cooling.
17. Return Air Enthalpy Sensor:
 - a. The return air enthalpy sensor shall be used in conjunction with an outdoor air enthalpy sensor to provide differential enthalpy control.
18. Indoor Air Quality (CO₂) Sensor:
 - a. Shall be able to provide demand ventilation indoor air quality (IAQ) control.
 - b. The IAQ sensor shall be available in duct mount, wall mount, or wall mount with LED display. The setpoint shall have adjustment capability.
19. Smoke detectors:
 - a. Shall be a Four-Wire Controller and Detector.
 - b. Shall be environmental compensated with differential sensing for reliable, stable, and drift-free sensitivity.
 - c. Shall use magnet-activated test/reset sensor switches.
 - d. Shall have tool-less connection terminal access.
 - e. Shall have a recessed momentary switch for testing and resetting the detector.
 - f. Controller shall include:
 - (1.) One set of normally open alarm initiation contacts for connection to an initiating device circuit on a fire alarm control panel.
 - (2.) Two Form-C auxiliary alarm relays for interface with rooftop unit or other equipment.
 - (3.) One Form-C supervision (trouble) relay to control the operation of the Trouble LED on a remote test/reset station.
 - (4.) Capable of direct connection to two individual detector modules.
 - (5.) Can be wired to up to 14 other duct smoke detectors for multiple fan shutdown applications
20. Winter start kit
 - a. Shall contain a bypass device around the low pressure switch.
 - b. Shall be required when mechanical cooling is required down to 25°F (-4°C).
 - c. Shall not be required to operate on an economizer when below an outdoor ambient of 40°F (4°C).
21. Time Guard
 - a. Shall prevent compressor short cycling by providing a 5-minute delay (±2 minutes) before restarting a compressor after shutdown for any reason.
 - b. One device shall be required per compressor.

