

INSTALLATION MANUAL

HIGH EFFICIENCY TUBULAR HEAT EXCHANGER SERIES

MODELS: GY8S*DH / GM8S*DH / LY8S*DH / LM8S*DH
(Single Stage Downflow / Horizontal / Low NOx)

40 - 130 MBH INPUT
(11.72 - 38.10 KW) INPUT



LIST OF SECTIONS

| | | | |
|------------------------|---|--------------------------------|----|
| SAFETY | 1 | TWINNING AND STAGING | 12 |
| DUCTWORK | 4 | VENT SYSTEM | 14 |
| FILTERS | 8 | SAFETY CONTROLS | 19 |
| GAS PIPING | 8 | START-UP AND ADJUSTMENTS | 20 |
| ELECTRICAL POWER | 9 | WIRING DIAGRAM | 27 |

LIST OF FIGURES

| | | | |
|--|----|--|----|
| Combustible Floor Base Accessory | 5 | Vent Termination | 14 |
| Typical Attic Installation | 6 | Typical Sidewall Vent Application | 15 |
| Typical Suspended Furnace / Crawl Space Installation | 7 | Typical Sidewall Vent and Termination Configuration | 15 |
| Dimensions | 7 | Home Layout | 16 |
| Gas Valve | 8 | Combustion Airflow Path Through The Furnace Casing | 17 |
| Downflow Gas Piping | 8 | Alternate Air Intake, Air Outlet and Chimney Connections | 17 |
| Horizontal Gas Piping | 8 | Air Inlet, Outlet and Chimney Connections | 17 |
| Electrical Wiring | 10 | Typical Chimney Connections | 17 |
| Thermostat Chart | 11 | Horizontal Air Inlet, Outlet and Chimney Connections | 18 |
| Accessory Connections | 12 | Outside and Ambient Combustion Air | 18 |
| Typical Twinned Furnace Application | 12 | Pressure Switch Tubing Routing | 19 |
| Single Stage Twinning Wiring Diagram | 13 | Gas Valve | 22 |
| Two-Stage Twinning Wiring Diagram | 13 | Reading Gas Pressure | 22 |
| Vent Termination 10 ft. (3.0 m) or less | 14 | Furnace Control Board | 23 |
| Vent Termination more than 10 ft. (3.0 m) | 14 | Wiring Diagram | 27 |

LIST OF TABLES

| | | | |
|--|----|--|----|
| Unit Clearances to Combustibles | 4 | Estimated Free Area | 17 |
| Minimum Duct Sizing For Proper Airflow | 5 | Unconfined Space Minimum Area in Square Inch | 18 |
| Round Duct Size | 5 | Free Area | 18 |
| Cabinet and Duct Dimensions | 7 | Inlet Gas Pressure Range | 22 |
| Recommended Filter Sizes | 8 | Nominal Manifold Pressure | 22 |
| Nominal Manifold Pressure - High Fire | 9 | Filter Performance - Pressure Drop Inches W.C. and (kPa) | 24 |
| Ratings & Physical / Electrical Data | 10 | Blower Performance CFM - (without filter) | 25 |
| Roof Pitch | 14 | Field Installed Accessories - Non Electrical | 26 |

SECTION I: SAFETY



This is a safety alert symbol. When you see this symbol on labels or in manuals, be alert to the potential for personal injury.

Understand and pay particular attention to the signal words **DANGER**, **WARNING**, or **CAUTION**.

DANGER indicates an **imminently** hazardous situation, which, if not avoided, **will result in death or serious injury**.

WARNING indicates a **potentially** hazardous situation, which, if not avoided, **could result in death or serious injury**.

CAUTION indicates a potentially hazardous situation, which, if not avoided **may result in minor or moderate injury**. It is also used to alert against unsafe practices and hazards involving only property damage.

WARNING

Improper installation may create a condition where the operation of the product could cause personal injury or property damage.

Improper installation, adjustment, alteration, service or maintenance can cause injury or property damage. Refer to this manual for assistance or for additional information, consult a qualified contractor, installer or service agency.

CAUTION

This product must be installed in strict compliance with the installation instructions and any applicable local, state, and national codes including, but not limited to building, electrical, and mechanical codes.

SPECIFIC SAFETY RULES AND PRECAUTIONS

1. Only Natural gas or Propane (LP) gas are approved for use with this furnace. Refer to the furnace rating plate or SECTION IV of these instructions.
2. Install this furnace only in a location and position as specified in SECTION I of these instructions.
3. A gas-fired furnace for installation in a residential garage must be installed as specified in SECTION I of these instructions.
4. Provide adequate combustion and ventilation air to the furnace space as specified in SECTION VI of these instructions.
5. Combustion products must be discharged outdoors. Connect this furnace to an approved vent system only, as specified in SECTION VI of these instructions.

WARNING

FIRE OR EXPLOSION HAZARD

Failure to follow the safety warnings exactly could result in serious injury, death or property damage.

Never test for gas leaks with an open flame. Use a commercially available soap solution made specifically for detection of leaks to check all connections. A fire or explosion may result causing property damage, personal injury or loss of life.

6. Test for gas leaks as specified in SECTION VIII of these instructions.
7. Always install the furnace to operate within the furnace's intended temperature rise range. Only connect the furnace to a duct system which has an external static pressure within the allowable range, as specified on the furnace rating plate.
8. When a furnace is installed so that supply ducts carry air circulated by the furnace to areas outside the space containing the furnace, the return air shall also be handled by duct(s) sealed to the furnace casing and terminating outside the space containing the furnace.
9. It is permitted to use the furnace for heating of buildings or structures under construction. Installation must comply with all manufacturer's installation instructions including:
 - Proper vent installation;
 - Furnace operating under thermostatic control;
 - Return air duct sealed to the furnace;
 - Air filters in place;
 - Set furnace input rate and temperature rise per rating plate marking;
 - Means for providing outdoor air required for combustion;
 - Return air temperature maintained between 55°F (13°C) and 80°F (27°C);
 - The **air filter must be replaced** upon substantial completion of the construction process;
 - Clean furnace, duct work and components upon substantial completion of the construction process, and verify furnace-operating conditions including ignition, input rate, temperature rise and venting, according to the manufacturer's instructions.
10. When installed in an Approved Modular Home or building constructed on-site, combustion air shall not be supplied from occupied spaces.
11. The size of the unit should be based on an acceptable heat loss calculation for the structure. ACCA, Manual J or other approved methods may be used.

SAFETY REQUIREMENTS

- This furnace should be installed in accordance with all national and local building/safety codes and requirements, local plumbing or waste water codes, and other applicable codes. In the absence of local codes, install in accordance with the National Fuel Gas Code ANSI Z223.1/NFPA 54, National Fuel Gas Code, and/or CAN/CGA B149.1 Natural Gas and Propane Installation Code (latest editions). Furnaces have been certified to the latest edition of standard ANSI Z21-47 • CSA 2.3.

- Refer to the unit rating plate for the furnace model number, and then see the dimensions page of this instruction for return air plenum dimensions in Figure 4. The plenum must be installed according to the instructions.
- Provide clearances from combustible materials as listed under Clearances to Combustibles in Table 1.
- Provide clearances for servicing ensuring that service access is allowed for both the burners and blower.
- These models **ARE NOT** CSA listed or approved for installation into a **Manufactured (Mobile) Home**.
- This furnace is not approved for installation in trailers or recreational vehicles.
- **Failure to carefully read and follow all instructions in this manual can result in furnace malfunction, death, personal injury and/or property damage.**
- Furnaces for installation on combustible flooring shall not be installed directly on carpeting, tile or other combustible material other than wood flooring.
- Check the rating plate and power supply to be sure that the electrical characteristics match. All models use nominal 115 VAC, 1 Phase, 60-Hertz power supply. **DO NOT CONNECT THIS APPLIANCE TO A 50 HZ POWER SUPPLY OR A VOLTAGE ABOVE 130 VOLTS.**
- Furnace shall be installed so the electrical components are protected from water.
- Installing and servicing heating equipment can be hazardous due to the electrical components and the gas fired components. Only trained and qualified personnel should install, repair, or service gas heating equipment. Untrained service personnel can perform basic maintenance functions such as cleaning and replacing the air filters. When working on heating equipment, observe precautions in the manuals and on the labels attached to the unit and other safety precautions that may apply.
- These instructions cover minimum requirements and conform to existing national standards and safety codes. In some instances these instructions exceed certain local codes and ordinances, especially those who have not kept up with changing residential and modular home construction practices. These instructions are required as a minimum for a safe installation.

COMBUSTION AIR QUALITY (LIST OF CONTAMINANTS)

The furnace will require **OUTDOOR AIR** for combustion when the furnace is located in any of the following environments.

- Restricted Environments
- Commercial buildings
- Buildings with indoor pools
- Furnaces installed in laundry rooms
- Furnaces installed in hobby or craft rooms
- Furnaces installed near chemical storage areas
- Chemical exposure

The furnace will require **OUTDOOR AIR** for combustion when the furnace is located in an area where the furnace is being exposed to the following substances and / or chemicals.

- Permanent wave solutions
- Chlorinated waxes and cleaners
- Chlorine based swimming pool chemicals
- Water softening chemicals
- De-icing salts or chemicals
- Carbon tetrachloride
- Halogen type refrigerants
- Cleaning solvents (such as perchloroethylene)
- Printing inks, paint removers, varnishes, etc.
- Hydrochloric acid
- Cements and glues
- Anti-static fabric softeners for clothes dryers
- Masonry acid washing materials

When outdoor air is used for combustion, the combustion air intake duct system termination must be located external to the building and in an area where there will be no exposure to the substances listed above.

▲ WARNING

The furnace area must not be used as a broom closet or for any other storage purposes, as a fire hazard may be created. Never store items such as the following on, near, or in contact with the furnace.

1. Spray or aerosol cans, rags, brooms, dust mops, vacuum cleaners or other cleaning tools.
2. Soap powders, bleaches, waxes or other cleaning compounds; plastic items or containers; gasoline, kerosene, cigarette lighter fluid, dry cleaning fluids or other volatile fluid.
3. Paint thinners and other painting compounds.
4. Paper bags, boxes or other paper products

Never operate the furnace with the blower door removed. To do so could result in serious personal injury and/or equipment damage.

FOR FURNACES INSTALLED IN THE COMMONWEALTH OF MASSACHUSETTS ONLY

For all side wall horizontally vented gas fueled equipment installed in every dwelling, building or structure used in whole or in part for residential purposes, including those owned or operated by the Commonwealth and where the side wall exhaust vent termination is less than seven (7) feet above finished grade in the area of the venting, including but not limited to decks and porches, the following requirements shall be satisfied:

1. **INSTALLATION OF CARBON MONOXIDE DETECTORS.** At the time of installation of the side wall horizontal vented gas fueled equipment, the installing plumber or gasfitter shall observe that a hard wired carbon monoxide detector with an alarm and battery back-up is installed on the floor level where the gas equipment is to be installed. In addition, the installing plumber or gasfitter shall observe that a battery operated or hard wired carbon monoxide detector with an alarm is installed on each additional level of the dwelling, building or structure served by the side wall horizontal vented gas fueled equipment. It shall be the responsibility of the property owner to secure the services of qualified licensed professionals for the installation of hard wired carbon monoxide detectors
 - a. In the event that the side wall horizontally vented gas fueled equipment is installed in a crawl space or an attic, the hard wired carbon monoxide detector with alarm and battery back-up may be installed on the next adjacent floor level.
 - b. In the event that the requirements of this subdivision can not be met at the time of completion of installation, the owner shall have a period of thirty (30) days to comply with the above requirements; provided, however, that during said thirty (30) day period, a battery operated carbon monoxide detector with an alarm shall be installed.
2. **APPROVED CARBON MONOXIDE DETECTORS.** Each carbon monoxide detector as required in accordance with the above provisions shall comply with NFPA 720 and be ANSI/UL 2034 listed and IAS certified.
3. **SIGNAGE.** A metal or plastic identification plate shall be permanently mounted to the exterior of the building at a minimum height of eight (8) feet above grade directly in line with the exhaust vent terminal for the horizontally vented gas fueled heating appliance or equipment. The sign shall read, in print size no less than one-half (1/2) inch in size, "**GAS VENT DIRECTLY BELOW. KEEP CLEAR OF ALL OBSTRUCTIONS**".
4. **INSPECTION.** The state or local gas inspector of the side wall horizontally vented gas fueled equipment shall not approve the installation unless, upon inspection, the inspector observes carbon monoxide detectors and signage installed in accordance with the provisions of 248 CMR 5.08(2)(a)1 through 4.

INSPECTION

As soon as a unit is received, it should be inspected for possible damage during transit. If damage is evident, the extent of the damage should be noted on the carrier's freight bill. A separate request for inspection by the carrier's agent should be made in writing. Also, before installation the unit should be checked for screws or bolts, which may have loosened in transit. There are no shipping or spacer brackets which need to be removed.

FURNACE LOCATION AND CLEARANCES**The furnace shall be located using the following guidelines:**

1. Where a minimum amount of air intake/vent piping and elbows will be required.
2. As centralized with the air distribution as possible.
3. Where adequate combustion air will be available (particularly when the appliance is not using outdoor combustion air).
4. Where it will not interfere with proper air circulation in the confined space.
5. Where the outdoor vent terminal will not be blocked or restricted. Refer to "VENT CLEARANCES" located in SECTION VI of these instructions. These minimum clearances must be maintained in the installation.
6. Where the unit will be installed in a level position with no more than 1/4" (0.64 cm) slope side-to-side and front-to-back.

Installation in freezing temperatures:

1. Furnace shall be installed in an area where ventilation facilities provide for safe limits of ambient temperature under normal operating conditions. Ambient temperatures may fall below 32° F (0° C) providing the flue temperature does not fall below 260° F (127° C) at any point in the flue pipe between the furnace and the chimney or a B-Vent. The flue products will condense in the vent pipe if the flue temperature falls below 260° F (127° C) causing the vent pipe to deteriorate rapidly.
2. Do not allow return air temperature to be below 55° F (13° C) for extended periods. To do so may cause condensation to occur in the main heat exchanger, leading to premature heat exchanger failure.

▲ WARNING

Improper installation in an ambient below 32°F (0.0° C) could create a hazard, resulting in damage, injury or death.

3. If this furnace is installed in an unconditioned space and an extended power failure occurs, there will be potential damage to the internal components. Following a power failure situation, do not operate the unit until inspection and repairs are performed.

Clearances for access:

Ample clearances should be provided to permit easy access to the unit. The following minimum clearances are recommended:

1. Twenty-four (24) inches (61 cm) between the front of the furnace and an adjacent wall or another appliance, when access is required for servicing and cleaning.
2. Eighteen (18) inches (46 cm) at the side where access is required for passage to the front when servicing or for inspection or replacement of flue/vent connections.

In all cases, accessibility clearances shall take precedence over clearances for combustible materials where accessibility clearances are greater.

WARNING

Downflow furnaces for installation on combustible flooring only when installed on the accessory combustible floor base on wood flooring only and shall not be installed directly on carpeting, tile or other combustible material.

Check the rating plate and power supply to be sure that the electrical characteristics match. All models use nominal 115 VAC, 1 Phase 60Hz power supply.

Furnace shall be installed so the electrical components are protected from water.

Installation in a residential garage:

A gas-fired furnace for installation in a residential garage must be installed so the burner(s) and the ignition source are located not less than eighteen (18) inches (46 cm) above the floor, and the furnace must be located or protected to avoid physical damage by vehicles.

TABLE 1: Unit Clearances to Combustibles

| Application | Top | Front | Rear | Left Side | Right Side | Flue | Floor/Bottom | Closet | Alcove | Attic | Line Contact |
|-------------------|----------|----------|----------|-----------|------------|----------|-----------------------|--------|--------|-------|------------------|
| | In. (cm) | In. (cm) | In. (cm) | In. (cm) | In. (cm) | In. (cm) | | | | | |
| Downflow | 1 (2.5) | 6 (15.2) | 0 (0.0) | 0 (0.0) | 3 (7.6) | 6 (15.2) | 1 (25.4) ¹ | Yes | Yes | Yes | No |
| Downflow B-Vent | 1 (2.5) | 3 (7.6) | 0 (0.0) | 0 (0.0) | 0 (0.0) | 1 (2.5) | 1 (25.4) ¹ | Yes | Yes | Yes | No |
| Horizontal | 1 (2.5) | 6 (15.2) | 0 (0.0) | 0 (0.0) | 3 (7.6) | 6 (15.2) | Combustible | No | Yes | Yes | Yes ² |
| Horizontal B-Vent | 1 (2.5) | 3 (7.6) | 0 (0.0) | 0 (0.0) | 0 (0.0) | 1 (2.5) | Combustible | No | Yes | Yes | Yes ² |

1. Special floor base or air conditioning coil required for use on combustible floor.
2. Line contact only permitted between lines formed by the intersection of the rear panel and side panel (top in horizontal position) of the furnace jacket and building joists, studs or framing.

SECTION II: DUCTWORK

DUCTWORK GENERAL INFORMATION

The duct system's design and installation must:

1. Handle an air volume appropriate for the served space and within the operating parameters of the furnace specifications.
2. Be installed in accordance with standards of NFPA (National Fire Protection Association) as outlined in NFPA pamphlets 90A and 90B (latest editions) or applicable national, provincial, or state, and local fire and safety codes.
3. Create a closed duct system. For residential and Modular Home installations, when a furnace is installed so that the supply ducts carry air circulated by the furnace to areas outside the space containing the furnace, the return air shall also be handled by a duct(s) sealed to the furnace casing and terminating outside the space containing the furnace.
4. Complete a path for heated or cooled air to circulate through the air conditioning and heating equipment and to and from the conditioned space.

CAUTION

The cooling coil must be installed in the supply air duct, downstream of the furnace. Cooled air may not be passed over the heat exchanger.

When the furnace is used in conjunction with a cooling coil, the coil must be installed parallel with, or in the supply air side of the furnace to avoid condensation in the primary heat exchanger. When a parallel flow arrangement is used, dampers or other means used to control airflow must be adequate to prevent chilled air from entering the furnace. If manually operated, the damper must be equipped with means to prevent the furnace or the air conditioner from operating unless the damper is in full heat or cool position.

WARNING

The duct system must be properly sized to obtain the correct airflow for the furnace size that is being installed.

Refer to Table 7 and the furnace rating plate for the correct rise range and static pressures

If the ducts are undersized, the result will be high duct static pressures and/or high temperature rises which can result in a heat exchanger OVERHEATING CONDITION. This condition can result in premature heat exchanger failure, which can result in personal injury, property damage, or death.

FLOOR BASE AND DUCTWORK INSTALLATION

Downflow Combustible Floor Base

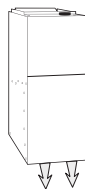

Installations on combustible material or floors must use a combustible floor base shown in Figure 1. Follow the instructions supplied with the combustible floor base accessory. This combustible floor base can be replaced with a matching cooling coil, properly sealed to prevent leaks. Follow the instructions supplied with the cooling coil cabinet for installing the cabinet to the duct connector. Refer to the installation instructions for additional information.

Downflow Duct Connectors

All downflow installations must use a suitable duct connector approved by the furnace manufacturer for use with this furnace. The duct connectors are designed to be connected to the rectangular duct under the floor and sealed. Refer to the instructions supplied with the duct connector for proper installation. Refer to the separate accessory parts list at the end of these instructions for the approved accessory duct connectors.

When replacing an existing furnace, if the existing plenum is not the same size as the new furnace then the existing plenum must be removed and a new plenum installed that is the proper size for the new furnace.

The duct system is a very important part of the installation. **If the duct system is improperly sized the furnace will not operate properly.** The ducts attached to the furnace plenum, should be of sufficient size so that the furnace operates at the specified external static pressure and within the air temperature rise specified on the nameplate.

Table 2 is a guide for determining whether the rectangular duct system that the furnace is being connected to be of sufficient size for proper furnace operation.

Use the Example below to help you in calculating the duct area to determine whether the ducts have sufficient area so that the furnace operates at the specified external static pressure and within the air temperature rise specified on the nameplate.

The following are general duct sizing guidelines that may not serve to requirements of every application.

Example: The furnace input is 80,000 BTUH with 1,200 CFM blower requirement. The recommended duct area is 216 sq. in, there are two 8 x 12 rectangular ducts attached to the plenum and there are two 7 inch round ducts attached to the furnace.

1. Take 8 x 12, which equals 96 sq. in. X 2, which equals 192 square inches then go to round duct size located in Table 3.
2. The square inch area for 7 inch round ducts is 38.4 sq. in. x 2 = 76.8 square inches.
3. Then take the 192 square inch from the rectangular duct and add it to the 76.8 sq. in. of round duct. The total square inch of duct attached to the furnace supply plenum is 268.8 total square inches. This exceeds the recommended 216 square inch of duct.

In this example, the duct system attached to the plenum has a sufficient area so that the furnace operates at the specified external static pressure and within the air temperature rise specified on the nameplate, providing the return duct is properly sized as well.

TABLE 2: Minimum Duct Sizing For Proper Airflow

| Input/Cabinet | Airflow | Return ¹ | Rectangular ² | Round ² | Supply ³ | Rectangular ² | Round ² |
|---------------|-----------------------|------------------------------------|--------------------------|--------------------|------------------------------------|--------------------------|--------------------|
| BTU/H (kW) | CFM (m ³) | In ² (cm ²) | in. x in. (cm x cm) | in. (cm) dia. | In ² (cm ²) | in. x in. (cm x cm) | in. (cm) dia. |
| 40/A (11.7) | 1200 (34.0) | 280 (1806) | 14 x 20 (35.6 x 50.8) | 18 (45.7) | 216 (1394) | 12 x 18 (30.5 x 45.7) | 16 (40.6) |
| 60/A (17.6) | 1200 (34.0) | 280 (1806) | 14 x 20 (35.6 x 50.8) | 18 (45.7) | 216 (1394) | 12 x 18 (30.5 x 45.7) | 16 (40.6) |
| 80/A (23.4) | 1200 (34.0) | 280 (1806) | 14 x 20 (35.6 x 50.8) | 18 (45.7) | 216 (1394) | 12 x 18 (30.5 x 45.7) | 16 (40.6) |
| 80/B (23.4) | 1600 (45.3) | 360 (2322) | 18 x 20 (45.7 x 50.8) | 22 (55.8) | 280 (1806) | 14 x 20 (35.6 x 50.8) | 18 (45.7) |
| 80/C (23.4) | 1600 (45.3) | 360 (2322) | 18 x 20 (45.7 x 50.8) | 22 (55.8) | 280 (1806) | 14 x 20 (35.6 x 50.8) | 18 (45.7) |
| 100/B (29.3) | 1200 (34.0) | 280 (1806) | 14 x 20 (35.6 x 50.8) | 18 (45.7) | 216 (1394) | 12 x 18 (30.5 x 45.7) | 16 (40.6) |
| 100/C (29.3) | 1600 (45.3) | 360 (2322) | 18 x 20 (45.7 x 50.8) | 22 (55.8) | 280 (1806) | 14 x 20 (35.6 x 50.8) | 18 (45.7) |
| 100/C (29.3) | 2000 (56.6) | 440 (2834) | 20 x 22 (50.8 x 55.8) | 24 (60.9) | 390 (2516) | 16 x 22 (40.6 x 55.8) | 22 (55.8) |
| 115/C (33.7) | 1600 (45.3) | 360 (2322) | 18 x 20 (45.7 x 50.8) | 22 (55.8) | 280 (1806) | 14 x 20 (35.6 x 50.8) | 18 (45.7) |
| 115/C (33.7) | 2000 (56.6) | 440 (2834) | 20 x 22 (50.8 x 55.8) | 24 (60.9) | 390 (2516) | 16 x 22 (40.6 x 55.8) | 22 (55.8) |
| 130/D (38.1) | 2000 (56.6) | 440 (2834) | 20 x 22 (50.8 x 55.8) | 24 (60.9) | 390 (2516) | 16 x 22 (40.6 x 55.8) | 22 (55.8) |

NOTE: This chart does not replace proper duct sizing calculations or take into account static pressure drop for run length and fittings. Watch out for the temperature rise and static pressures.

1. Maximum return air velocity in rigid duct @ 700 feet per minute (213 m/min).
2. Example return main trunk duct minimum dimensions.
3. Maximum supply air velocity in rigid duct @ 900 feet per minute (274 m/min).

TABLE 3: Round Duct Size

| Round Duct Size | Calculated Area For Each Round Duct Size |
|-----------------|--|
| inches (cm) | Sq.in (cm ²) |
| 5 (13) | 19.6 (126) |
| 6 (15) | 28.2 (182) |
| 7 (18) | 38.4 (248) |
| 8 (20) | 50.2 (324) |
| 9 (23) | 63.6 (410) |
| 10 (25) | 78.5 (506) |
| 11 (28) | 95 (613) |
| 12 (30) | 113.1 (730) |
| 13 (33) | 132.7 (856) |
| 14 (36) | 153.9 (993) |

1. The Air Temperature Rise is determined by subtracting the Return Air Temperature Reading from the Supply Air Temperature Reading.
2. The External Static Pressure is determined by adding the Supply Duct Static Pressure reading to the Return Duct Static Pressure reading and adding the pressure drop across any applied a-coil and return air filter.

Tables 2 and 3 are to be used as a guide only to help the installer determine if the duct sizes are large enough to obtain the proper air flow (CFM) through the furnace. Tables 2 and 3 ARE NOT to be used to design ductwork for the building where the furnace is being installed. There are several variables associated with proper duct sizing that are not included in the tables. To properly design the ductwork for the building, refer to the ASHRAE Fundamentals Handbook, chapter on "DUCT DESIGN" or a company that specializes in Residential and Modular

Home duct designs.

IMPORTANT: If the supply air duct is being connected to the furnace without the use of an accessory duct connector, then a transition duct must be installed with flanges or tabs that are securely attached and sealed to the supply air duct and to the base of the furnace. The transition duct must have insulation between the transition duct and any combustible material.

The transition duct must be the same dimensional size as the rectangular opening in the base of the furnace.

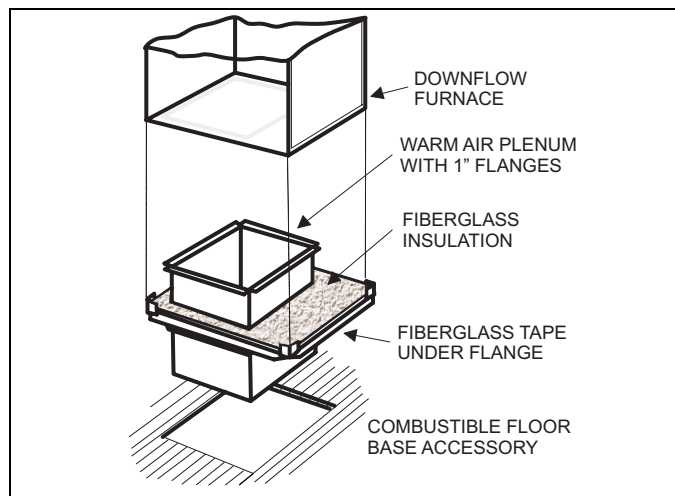

FIGURE 1: Combustible Floor Base Accessory

⚠ WARNING

The supply air temperature **MUST NEVER** exceed the **Maximum Outlet Air Temperature**, specified on the nameplate.

Operating the furnace above the maximum outlet air temperature will cause the heat exchanger to overheat, causing premature heat exchanger failure. Improper duct sizing, dirty air filters, incorrect manifold pressure, incorrect gas orifice and/or a faulty limit switch can cause the furnace to operate above the maximum supply air temperature. Refer to SECTIONS II, III and VIII for additional information on correcting the problem.

Downflow Air Conditioning Coil Cabinet

The furnace should be installed with coil cabinet part number specifically intended for downflow application. If a matching cooling coil is used, it may be placed directly on the furnace outlet and sealed to prevent leakage. For details of the coil cabinet dimensions and installation requirements, refer to the installation instructions supplied with the coil cabinet.

Attach the air conditioning coil cabinet to the duct connector, and then position the furnace on top of the coil cabinet. The connection to the furnace, air conditioning coil cabinet, duct connector, and supply air duct must be sealed to prevent air leakage.

IMPORTANT: On all installations without a coil, a removable access panel is recommended in the outlet duct such that smoke or reflected light would be observable inside the casing to indicate the presence of leaks in the heat exchanger. This access cover shall be attached in such a manner as to prevent leaks.

HORIZONTAL MODELS

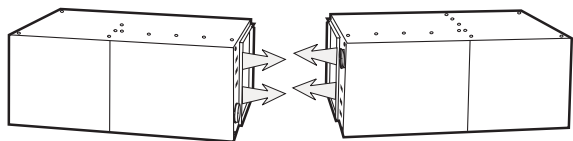

IMPORTANT: This furnace may be installed in a horizontal position on either side as shown above. **It must not be installed on its back.**

Horizontal Installations With a Cooling Coil Cabinet

The furnace should be installed with coil cabinet part number specifically intended for Horizontal application. If a matching cooling coil is used, it may be placed directly on the furnace outlet and sealed to prevent leakage. Follow the coil instructions for installing the supply plenum. For details of the coil cabinet dimensions and installation requirements, refer to the installation instructions supplied with the coil cabinet.

Attach the supply plenum to the air conditioning coil cabinet outlet duct flanges through the use of S cleat material when a metal plenum is used. The use of an approved flexible duct connector is recommended on all installations. The connection to the furnace, air conditioning coil cabinet and the supply plenum should be sealed to prevent air leakage. The sheet metal should be cross-hatched to eliminate any popping of the sheet metal when the indoor fan is energized.

The minimum plenum height is 12" (30.5 cm). If the plenum is shorter than 12" (30.5 cm) the turbulent air flow may cause the limit controls not to operate as designed, or the limit controls may not operate at all. Also the plastic drain pan in the air conditioning coil can overheat and melt. Refer to the installation instructions supplied with the air conditioning coil for additional information.

Horizontal Installations Without a Cooling Coil Cabinet

When installing this appliance, the furnace must be installed so as to create a closed duct system, the supply duct system must be connected to the furnace outlet and the supply duct system must terminate outside the space containing the furnace. When replacing an existing furnace, if the existing plenum is not the same size as the new furnace then the existing plenum must be removed and a new plenum installed that is the proper size for the new furnace.

Attach the supply plenum to the furnace outlet duct flanges through the use of S cleat material when a metal plenum is used. The use of an approved flexible duct connector is recommended on all installations. This connection should be sealed to prevent air leakage. The sheet metal should be cross-hatched to eliminate any popping of the sheet metal when the indoor fan is energized. On all installations without a coil, a removable access panel is recommended in the outlet duct such that smoke or reflected light would be observable inside the casing to indicate the presence of leaks in the heat exchanger. This access cover shall be attached in such a manner as to prevent leaks.

Residential and Modular Home Horizontal Return Plenum Connections

The return duct system must be connected to the furnace inlet and the return duct system must terminate outside the space containing the furnace. When replacing an existing furnace, if the existing plenum is not the same size as the new furnace then the existing plenum must be removed and a new plenum installed that is the proper size for the new furnace.

Attach the return plenum to the furnace inlet duct flanges. This is typically through the use of S cleat material when a metal plenum is used. The use of an approved flexible duct connector is recommended on all installations. The connection of the plenum to the furnace and all the ducts connecting to the plenum must be sealed to prevent air leakage. The sheet metal should be cross-hatched to eliminate any popping of the sheet metal when the indoor fan is energized.

The duct system is a very important part of the installation. If the duct system is improperly sized the furnace will not operate properly. The ducts attached to the furnace must be of sufficient size so that the furnace operates at the specified external static pressure and within the air temperature rise specified on the nameplate.

Attic installations must meet all minimum clearances to combustibles and have floor support with required service accessibility.

IMPORTANT: if an external mounted filter rack is being used see the instructions provided with that accessory for proper hole cut size.

ATTIC INSTALLATION

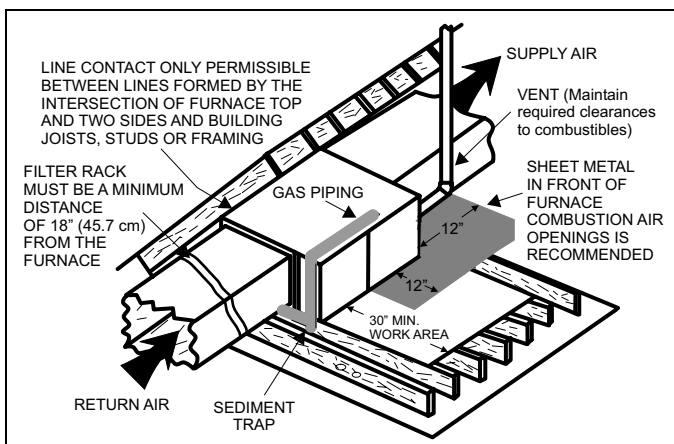

FIGURE 2: Typical Attic Installation

This appliance is design certified for line contact when the furnace is installed in the horizontal left or right position. The line contact is only permissible between lines that are formed by the intersection of the top and two sides of the furnace and the building joists, studs or framing. This line may be in contact with combustible material.

⚠ WARNING

When a furnace is installed in an attic or other insulated space, keep all insulating materials at least 12 inches (30.5 cm) away from furnace and burner combustion air openings.

SUSPENDED FURNACE / CRAWL SPACE INSTALLATION

The furnace can be hung from floor joists or installed on suitable blocks or pad. Blocks or pad installations shall provide adequate height to ensure the unit will not be subject to water damage. Units may also be suspended from rafters or floor joists using rods, pipe angle supports or straps. Angle supports should be placed at the supply air end and near the blower deck. Do not support at return air end of unit. All four suspension points must be level to ensure quiet furnace operation. When suspending the furnace use a secure platform constructed of plywood or other building material secured to the floor joists. Refer to Figure 3 for typical crawl space installation.

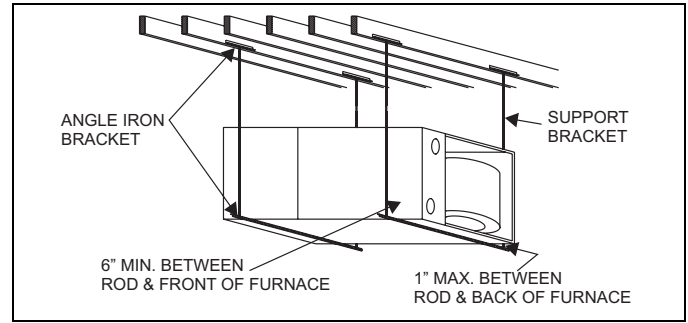

FIGURE 3: Typical Suspended Furnace / Crawl Space Installation

CAUTION

In any application where temperatures below freezing are possible, see "INSTALLATION IN FREEZING TEMPERATURES" in SECTION I

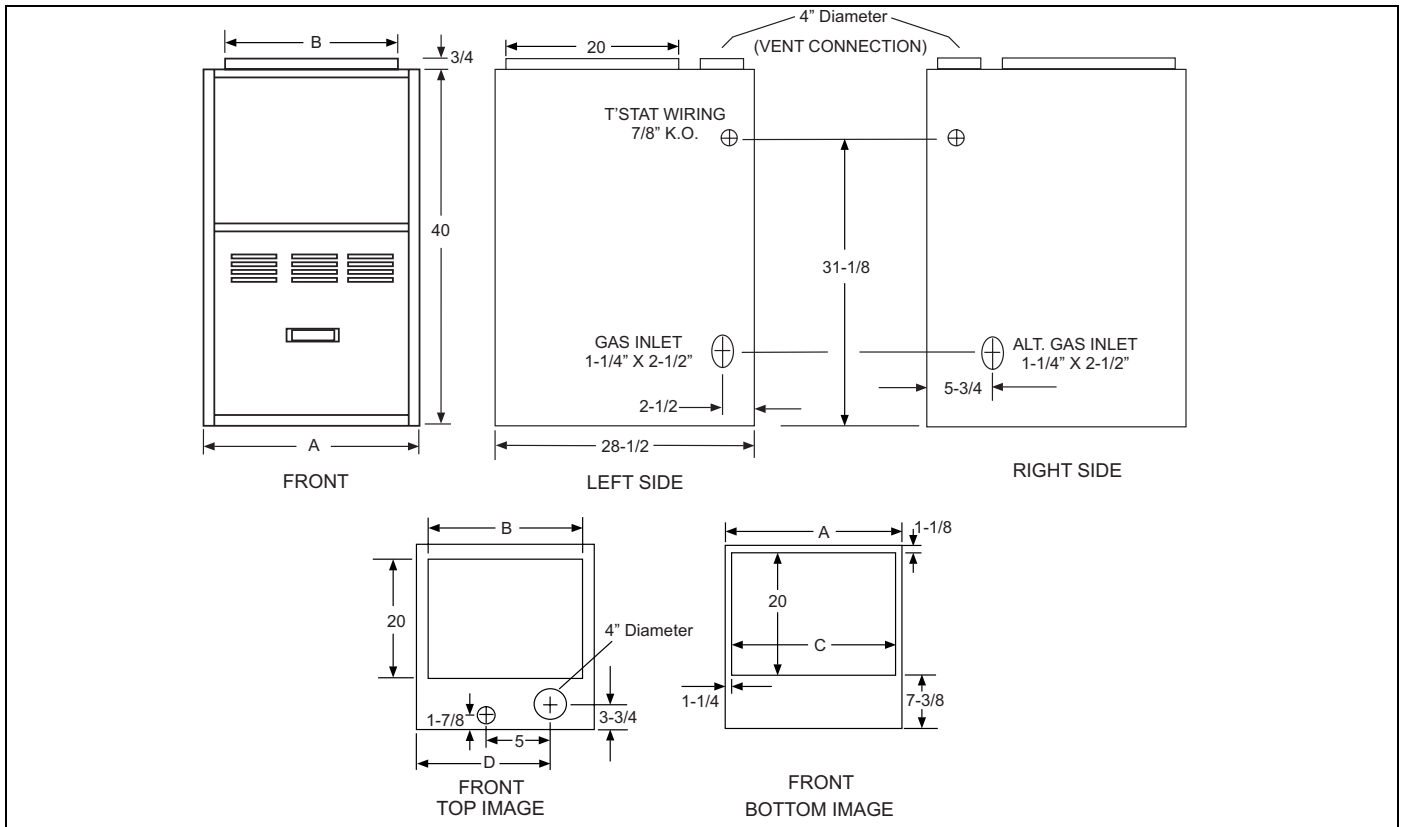

FIGURE 4: Dimensions

TABLE 4: Cabinet and Duct Dimensions

| BTUH (kW) Input | Airflow CFM (m ³ /min) | Cabinet Size | Cabinet Dimension | | | | | | | |
|--------------------|--------------------------------------|-----------------|-------------------|--------|--------|--------|--------|--------|--------|-------|
| | | | A | A (cm) | B | B (cm) | C | C (cm) | D | D(cm) |
| 40 (11.7) | 1200 (34.0) | A | 14 1/2 | 36.8 | 13 1/4 | 33.6 | 12 | 30.5 | 10 3/8 | 26.4 |
| 60 (17.6) | 1200 (34.0) | A | 14 1/2 | 36.8 | 13 1/4 | 33.6 | 12 | 30.5 | 10 3/8 | 26.4 |
| 80 (23.4) | 1200 (34.0) | A | 14 1/2 | 36.8 | 13 1/4 | 33.6 | 12 | 30.5 | 10 3/8 | 26.4 |
| 80 (23.2) | 1600 (45.3) | B | 17 1/2 | 44.4 | 16 1/4 | 41.3 | 15 | 38.1 | 11-3/4 | 29.8 |
| 80 (23.2) | 1600 (45.3) | C | 21 | 53.3 | 19 3/4 | 50.2 | 18-1/2 | 47.0 | 13 1/2 | 34.3 |
| 100 (29.3) | 1200 (34.0) | B | 17 1/2 | 44.4 | 16 1/4 | 41.3 | 15 | 38.1 | 11 3/4 | 29.8 |
| 100 (29.3) | 1600 (45.3) | C | 21 | 53.3 | 19 3/4 | 50.2 | 18-1/2 | 38.1 | 13 1/2 | 34.3 |
| 100 (29.3) | 2000 (56.6) | C | 21 | 53.3 | 19 3/4 | 50.2 | 18-1/2 | 47.0 | 13 1/2 | 34.3 |
| 115 (33.7) | 1600 (45.3) | C | 21 | 53.3 | 19 3/4 | 50.2 | 18-1/2 | 47.0 | 13 1/2 | 34.3 |
| 115 (33.7) | 2000 (56.6) | C | 21 | 53.3 | 19 3/4 | 50.2 | 18-1/2 | 47.0 | 13 1/2 | 34.3 |
| 130 (38.1) | 2000 (56.6) | D | 24 1/2 | 62.2 | 23 1/4 | 59.1 | 22 | 55.9 | 15 1/4 | 38.7 |

RESIDENTIAL AND MODULAR HOME DOWNFLOW RETURN PLENUM CONNECTION

The return duct system must be connected to the furnace inlet and the return duct system must terminate outside the space containing the furnace. When replacing an existing furnace, if the existing plenum is not the same size as the new furnace then the existing plenum must be removed and a new plenum installed that is the proper size for the new furnace.

Attach the return plenum to the furnace inlet duct flanges. This is typically through the use of S cleat material when a metal plenum is used. The use of an approved flexible duct connector is recommended on all installations. The connection of the plenum to the furnace and all the ducts connecting to the plenum must be sealed to prevent air leakage. The sheet metal should be cross-hatched to eliminate any popping of the sheet metal when the indoor fan is energized.

The duct system is a very important part of the installation. If the duct system is improperly sized the furnace will not operate properly. The ducts attached to the furnace must be of sufficient size so that the furnace operates at the specified external static pressure and within the air temperature rise specified on the nameplate.

IMPORTANT: If an external mounted filter rack is being used see the instructions provided with that accessory for proper hole cut size.

SECTION III: FILTERS

FILTER INSTALLATION

All applications require the use of an external filter. All filters and mounting provisions must be field supplied. Refer to Tables 5 & 16 for accessory External Filter Kits.

IMPORTANT: Air velocity through throwaway type filters must not exceed 300 feet per minute (91 m/min). All velocities over this require the use of high velocity filters. Refer to Table 14.

TABLE 5: Recommended Filter Sizes

| Cabinet Size | Top Return (in) | Top Return (cm) |
|--------------|-----------------|-----------------|
| A | (2) 14 x 20 | (2) 35.6 x 50.8 |
| B | (2) 14 x 20 | (2) 35.6 x 50.8 |
| C | (2) 14 x 20 | (2) 35.6 x 50.8 |
| D | (2) 14 x 20 | (2) 35.6 x 50.8 |

NOTES:

- Air velocity through throwaway type filters may not exceed 300 feet per minute. All velocities over this require the use of high velocity filters.

HORIZONTAL APPLICATION

Horizontal Filters

All filters and mounting provisions must be field supplied. Filters(s) may be located in the duct system external to the furnace or in a return filter grille(s). Filters(s) may be located in the duct system using an external duct filter box attached to the furnace plenum. Any branch duct (rectangular or round duct) attached to the plenum must attach to the vertical plenum above the filter height. The use of straps and / or supports is required to support the weight of the external filter box.

CAUTION

All installations must have a filter installed.

SECTION IV: GAS PIPING

GAS SAFETY

IMPORTANT: Plan your gas supply before determining the correct gas pipe entry. Use 90-degree service elbow(s), or short nipples and conventional 90-degree elbow(s) to enter through the cabinet access holes.

DANGER

An overpressure protection device, such as a pressure regulator, must be installed in the gas piping system upstream of the furnace and must act to limit the downstream pressure to the gas valve so it does not exceed 0.5 PSI (14" w.c. (3.48 kPa)). Pressures exceeding 0.5 PSI (14" w.c. (3.48 kPa)) at the gas valve will cause damage to the gas valve, resulting in a fire or explosion or cause damage to the furnace or some of its components that will result in property damage and loss of life.

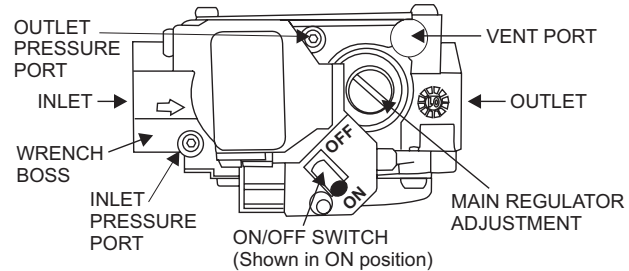

FIGURE 5: Gas Valve

GAS PIPING INSTALLATION

Properly sized wrought iron, approved flexible or steel pipe must be used when making gas connections to the unit. If local codes allow the use of a flexible gas appliance connection, always use a new listed connector. Do not use a connector that has previously serviced another gas appliance.

Some utility companies or local codes require pipe sizes larger than the minimum sizes listed in these instructions and in the codes. The furnace rating plate and the instructions in this section specify the type of gas approved for this furnace - only use those approved gases. The installation of a drip leg and ground union is required. Refer to Figures 6 & 7.

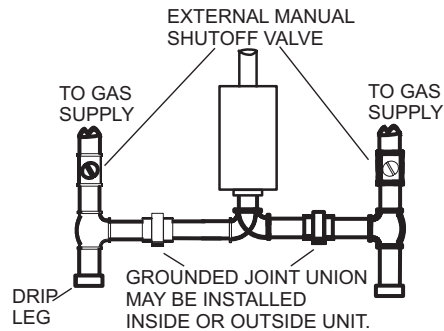

FIGURE 6: Downflow Gas Piping

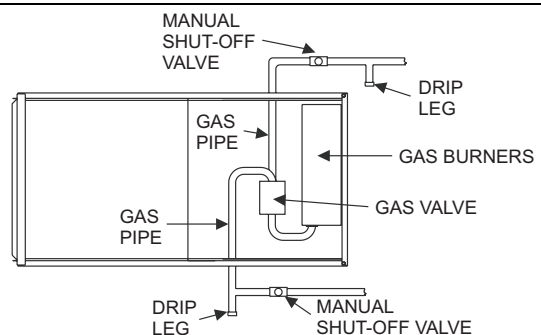

FIGURE 7: Horizontal Gas Piping

IMPORTANT: An accessible manual shut-off valve must be installed upstream of the furnace gas controls and within six (6) feet (1.8 m) of the furnace.

The furnace must be isolated from the gas supply piping system by closing its individual external manual shut-off valve during any pressure testing of the gas supply piping system at pressures equal to or less than 1/2 psig (3.5 kPa).

CAUTION

Never apply a pipe wrench to the body of the gas valve when installing piping. A wrench must be placed on the octagonal hub located on the gas inlet side of the valve. Placing a wrench to the body of the gas valve will damage the valve causing improper operation and/or the valve to leak.

Gas piping may be connected from either side of the furnace using any of the gas pipe entry knockouts on both sides of the furnace. Refer to Figure 4 dimensions.

GAS ORIFICE CONVERSION FOR PROPANE (LP)

This furnace is constructed at the factory for natural gas-fired operation, but may be converted to operate on propane (LP) gas by using a factory-supplied LP conversion kit. Follow the instructions supplied with the LP kit. Refer to Table 6 or the instructions in the propane (LP) conversion kit for the proper gas orifice size.

TABLE 6: Nominal Manifold Pressure - High Fire

| Manifold Pressures (in wc) | | | | |
|-----------------------------------|-----------|-----------------|-----------|-----------|
| | | Altitude (feet) | | |
| | | 0-7999 | 8000-8999 | 9000-9999 |
| Gas Heating Value (BTU/cu ft.) | 800 | 3.5 | 3.5 | 3.5 |
| | 850 | 3.5 | 3.5 | 3.5 |
| | 900 | 3.5 | 3.5 | 3.5 |
| | 950 | 3.5 | 3.5 | 3.3 |
| | 1000 | 3.5 | 3.2 | 2.9 |
| | 1050 | 3.5 | 2.9 | 2.7 |
| | 1100 | 3.2 | 2.7 | 2.4 |
| | 2500 (LP) | 9.8 | 8.2 | 7.5 |

WARNING

LoNOx furnaces requiring propane (LP) gas must have the LoNOx screens removed prior to installation and operation. See the instructions supplied with the propane conversion kit or the start up procedure at the back of these instructions on proper removal of the NOx screens.

HIGH ALTITUDE GAS ORIFICE CONVERSION

This furnace is constructed at the factory for natural gas-fired operation at 0 – 8,000 feet (0-m – 2,438 m) above sea level.

The manifold pressure must be changed in order to maintain proper and safe operation when the furnace is installed in a location where the altitude is greater than 8,000 feet (2,438 m) above sea level. Refer to Table 6 for proper manifold pressure settings.

HIGH ALTITUDE PRESSURE SWITCH CONVERSION

For installation where the altitude is less than 8,000 feet (2,438 m), it is not required that the pressure switch be changed. For altitudes above 8,000 feet (2,438 m), see Table 16 Field Installed Accessories - High Altitude Pressure Switch.

| Manifold Pressures (kpa) | | | | |
|--------------------------------|-----------|--------------|-----------|-----------|
| | | Altitude (m) | | |
| | | 0-2437 | 2438-2742 | 2743-3048 |
| Gas Heating Value (MJ/cu m) | 29.8 | 0.87 | 0.87 | 0.87 |
| | 31.7 | 0.87 | 0.87 | 0.87 |
| | 33.5 | 0.87 | 0.87 | 0.87 |
| | 35.4 | 0.87 | 0.87 | 0.81 |
| | 37.3 | 0.87 | 0.80 | 0.73 |
| | 39.1 | 0.87 | 0.73 | 0.67 |
| | 41.0 | 0.80 | 0.66 | 0.61 |
| | 93.2 (LP) | 2.44 | 2.03 | 1.86 |

DANGER

PROPANE AND HIGH ALTITUDE CONVERSION KITS

It is very important to choose the correct kit and/or gas orifices for the altitude and the type of gas for which the furnace is being installed.

Only use natural gas in furnaces designed for natural gas. Only use propane (LP) gas for furnaces that have been properly converted to use propane (LP) gas. Do not use this furnace with butane gas.

Incorrect gas orifices or a furnace that has been improperly converted will create an extremely dangerous condition resulting in premature heat exchanger failure, excessive sooting, high levels of carbon monoxide, personal injury, property damage, a fire hazard and/or death.

High altitude and propane (LP) conversions are required in order for the appliance to satisfactorily meet the application.

An authorized distributor or dealer must make all gas conversions.

In Canada, a certified conversion station or other qualified agency, using factory specified and/or approved parts, must perform the conversion.

The installer must take every precaution to insure that the furnace has been converted to the proper gas orifice size when the furnace is installed. Do not attempt to drill out any orifices to obtain the proper orifice size. Drilling out a gas orifice will cause misalignment of the burner flames, causing premature heat exchanger burnout, high levels of carbon monoxide, excessive sooting, a fire hazard, personal injury, property damage and/or death.

SECTION V: ELECTRICAL POWER

Electrical Power Connections

Field wiring to the unit must be grounded. Electric wires that are field installed shall conform to the temperature limitation of 63°F (35°C) rise when installed in accordance with these instructions. Refer to Table 7 in these instructions for specific furnace electrical data.

CAUTION

Use copper conductors only.

TABLE 7: Ratings & Physical / Electrical Data

| Input | | Output | | Nominal Airflow | | Cabinet Width | | Total Unit Amps | AFUE | Air Temp. Rise | |
|-------|------|----------------------|------|-----------------|---------------------|---------------|-------------|--------------------------|--------------------------------------|------------------|-------|
| MBH | kW | MBH | kW | CFM | m ³ /min | In. | cm | | | °F | °C |
| 40 | 11.7 | 32 | 9.4 | 1200 | 34.0 | 14-1/2 | 36.8 | 9.0 | 80.0 | 20-50 | 11-28 |
| 60 | 17.6 | 48 | 14.1 | 1200 | 34.0 | 14-1/2 | 36.8 | 9.0 | 80.0 | 25-55 | 13-31 |
| 80 | 23.5 | 64 | 18.8 | 1200 | 34.0 | 14-1/2 | 36.8 | 9.0 | 80.0 | 35-65 | 19-36 |
| 80 | 23.5 | 64 | 18.8 | 1600 | 45.3 | 17-1/2 | 44.5 | 12.0 | 80.0 | 25-55 | 13-31 |
| 80 | 23.5 | 64 | 18.8 | 1600 | 45.3 | 21 | 53.3 | 12.0 | 80.0 | 25-55 | 13-31 |
| 100 | 29.3 | 80 | 23.4 | 1200 | 34.0 | 17-1/2 | 44.5 | 12.0 | 80.0 | 40-70 | 22-39 |
| 100 | 29.3 | 80 | 23.4 | 1600 | 45.3 | 21 | 53.3 | 12.0 | 80.0 | 25-55 | 13-31 |
| 100 | 29.3 | 80 | 23.4 | 2000 | 56.6 | 21 | 53.3 | 14.0 | 80.0 | 25-55 | 13-31 |
| 115 | 33.7 | 92 | 26.9 | 1600 | 45.3 | 21 | 53.3 | 12.0 | 80.0 | 35-65 | 19-36 |
| 115 | 33.7 | 92 | 26.9 | 2000 | 56.6 | 21 | 53.3 | 14.0 | 80.0 | 30-60 | 17-33 |
| 130 | 38.1 | 104 | 30.5 | 2000 | 56.6 | 24-1/2 | 62.2 | 14.0 | 80.0 | 40-70 | 22-39 |
| Input | | Max. Outlet Air Temp | | Blower | | Blower Size | | Max Over-Current Protect | Min. wire Size (awg) @ 75 ft one way | Operation Weight | |
| MBH | kW | °F | °C | Hp | Amps | In. | cm | | | LBS | Kg |
| 40 | 11.7 | 150 | 65.6 | 1/3 | 6.2 | 10 x 8 | 25.4 x 20.3 | 20 | 14 | 100 | 45.4 |
| 60 | 17.6 | 155 | 68.3 | 1/3 | 6.2 | 10 x 8 | 25.4 x 20.3 | 20 | 14 | 110 | 49.9 |
| 80 | 23.5 | 165 | 73.9 | 1/3 | 6.2 | 10 x 8 | 25.4 x 20.3 | 20 | 14 | 120 | 54.4 |
| 80 | 23.5 | 160 | 71.1 | 3/4 | 11.0 | 11 x 10 | 27.9 x 25.4 | 20 | 14 | 130 | 59.0 |
| 80 | 23.5 | 160 | 71.1 | 3/4 | 11.0 | 10 x 10 | 25.4 x 25.4 | 20 | 14 | 130 | 59.0 |
| 100 | 29.3 | 170 | 76.7 | 1/2 | 7.0 | 10 x 8 | 25.4 x 20.3 | 20 | 14 | 125 | 56.7 |
| 100 | 29.3 | 155 | 68.3 | 3/4 | 11.0 | 11 X 10 | 27.9 x 25.4 | 20 | 14 | 140 | 63.5 |
| 100 | 29.3 | 155 | 68.3 | 1 | 12.2 | 11 x 11 | 27.9 x 27.9 | 20 | 12 | 140 | 63.5 |
| 115 | 33.7 | 165 | 73.9 | 3/4 | 11.0 | 11 x 10 | 27.9 x 25.4 | 20 | 14 | 150 | 68.0 |
| 115 | 33.7 | 160 | 71.1 | 1 | 12.2 | 11 x 11 | 27.9 x 27.9 | 20 | 12 | 150 | 68.0 |
| 130 | 38.1 | 170 | 76.7 | 1 | 12.2 | 11 x 11 | 27.9 x 27.9 | 20 | 12 | 160 | 72.6 |

Wire size and over current protection must comply with the National Electrical Code (NFPA-70-latest edition) and all local codes. The furnace shall be installed so that the electrical components are protected from water. Annual Fuel Utilization Efficiency (AFUE) numbers are determined in accordance with DOE Test procedures.

SUPPLY VOLTAGE CONNECTIONS

IMPORTANT: The power connection leads and wiring box may be relocated to the left side of the furnace. Remove the screws and cut wire tie holding excess wiring. Reposition on the left side of the furnace and fasten using holes provided.

1. Provide a power supply separate from all other circuits. Install overcurrent protection and disconnect switch per local/national electrical codes. The switch should be close to the unit for convenience in servicing. With the disconnect or fused switch in the OFF position, check all wiring against the unit wiring label. Refer to the wiring diagram, Figure 30, in this instruction.
2. Remove the screws retaining the junction box cover. Route the power wiring through the opening in the unit into the junction box with a conduit connector or other proper connection. In the junction box there will be three (3) wires, a Black Wire, a White Wire and a Green Wire. Connect the power supply as shown on the unit wiring label on the inside of the blower compartment door or Figure 8. The black furnace lead must be connected to the L1 (hot) wire from the power supply. The white furnace lead must be connected to neutral. Connect the green furnace lead (equipment ground) to the power supply ground. An alternate wiring method is to use a field provided 2" (5.1 cm) x 4" (10.2 cm) box and cover on the outside of the furnace. Route the furnace leads into the box using a protective bushing where the wires pass through the furnace panel. After making the wiring connections replace the wiring box cover and screws.
3. The furnace's control system requires correct polarity of the power supply and a proper ground connection. If the power supply polarity is reversed, the control board will flash nine (9) times. The furnace will not operate until the polarity is corrected. Refer to "FURNACE DIAGNOSTICS" section of the "User's Information, Maintenance, & Service Manual" provided with this furnace for symptoms of reversed power supply polarity.

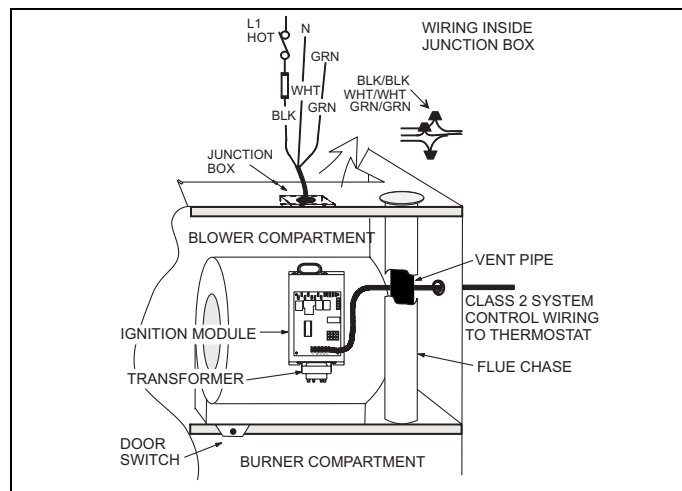

FIGURE 8: Electrical Wiring

LOW VOLTAGE CONTROL WIRING CONNECTIONS

Install the field-supplied thermostat by following the instructions that come with the thermostat. With the thermostat set in the OFF position and the main electrical source disconnected, connect the thermostat wiring from the wiring connections on the thermostat to the terminal board on the ignition module, as shown in Figure 9. Electronic thermostats may require the common wire to be connected as shown in Figure 9. Apply strain relief to thermostat wires passing through cabinet. If air conditioning equipment is installed, use thermostat wiring to connect the Y and C terminals on the furnace control board to the proper wires on the condensing unit (unit outside).

For additional connection diagrams for all UPG equipment refer to "Low Voltage System Wiring" document available online at www.upgnet.com in the Product Catalog Section.

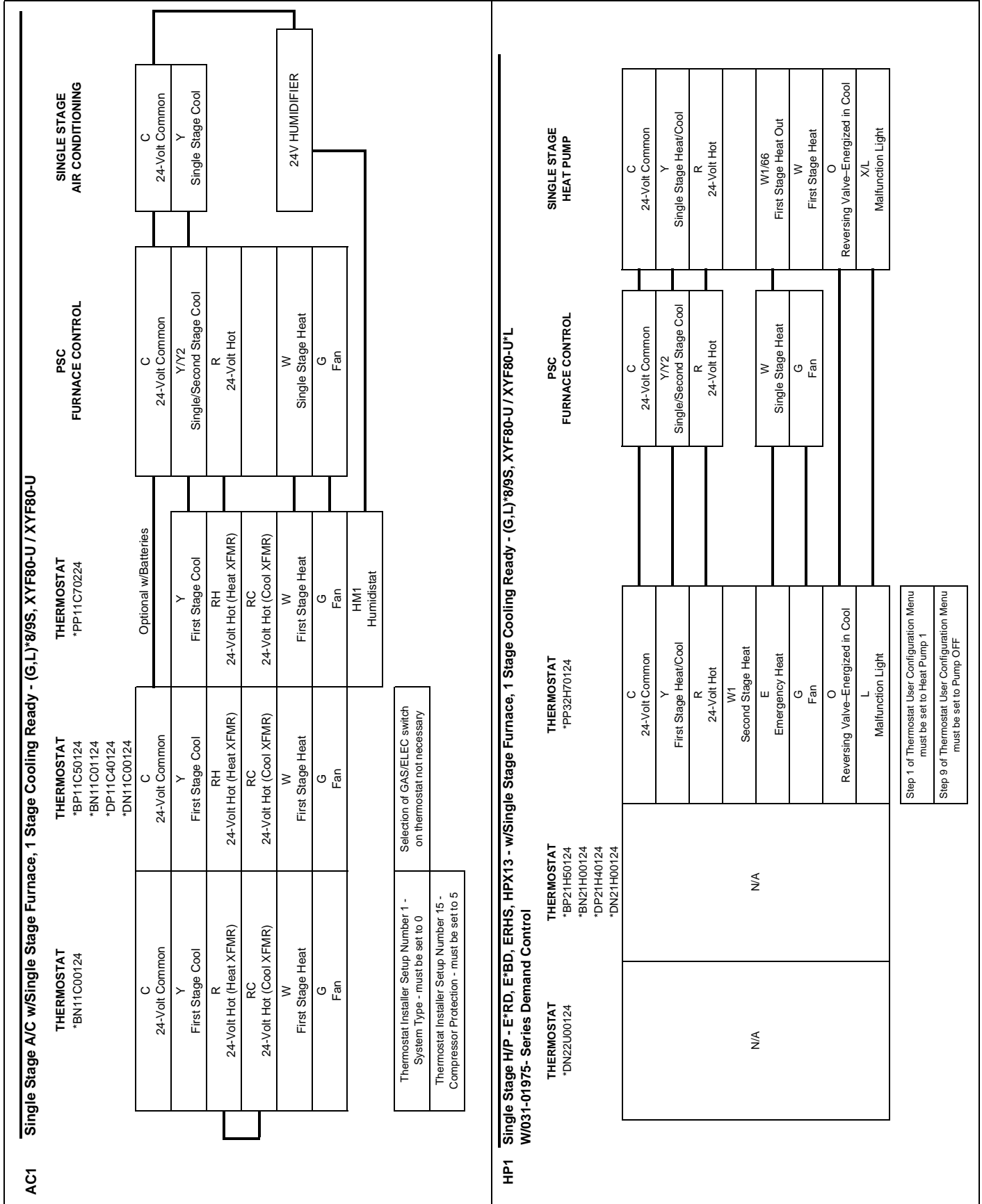

FIGURE 9: Thermostat Chart

Set the heat anticipator in the room thermostat as shown below. Setting it lower will cause short cycles. Setting it higher will cause the room temperature to exceed the setpoint.

| | |
|-------------------------|---------|
| Single Stage Thermostat | .4 Amps |
|-------------------------|---------|

IMPORTANT: Some electronic thermostats do not have adjustable heat anticipators. They may have other type cycle rate adjustments. Follow the thermostat manufacturer's instructions.

The 24-volt, 40 VA transformer is sized for the furnace components only, and should not be connected to power auxiliary devices such as humidifiers, air cleaners, etc. The transformer may provide power for an air conditioning unit contactor.

ACCESSORY CONNECTIONS

The furnace control will allow power-switching control of various accessories. Refer to Figure 10, for connection details.

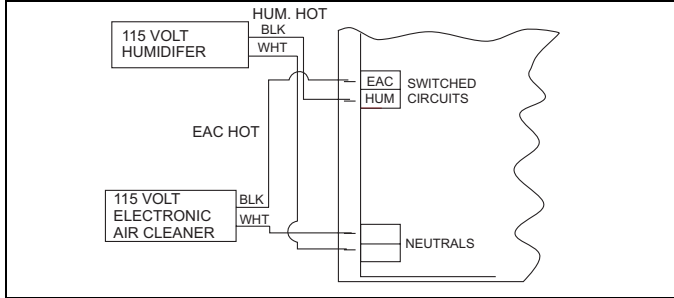

FIGURE 10: Accessory Connections

ELECTRONIC AIR CLEANER CONNECTION

Two 1/4" (0.64 cm) spade terminals (EAC and NEUTRAL) for electronic air cleaner connections are located on the control board. The terminals provide 115 VAC (1.0 amp maximum) during circulating blower operation.

HUMIDIFIER CONNECTION

Two 1/4" (0.64 cm) spade terminals (HUM and NEUTRAL) for humidifier connections are located on the control board. The terminals provide 115 VAC (1.0 amp maximum) during heating system operation.

SECTION VI: TWINNING AND STAGING

In applications where more heating capacity or more airflow capacity is needed than what one furnace can deliver, twinning can be used to make two furnaces operate in tandem. When two furnaces are installed using the same duct system, it is very important that the two furnace circulating air blowers operate in unison. If one blower starts before the second blower, the duct system will become pressurized and the blower on the second furnace will turn backwards causing the second furnace to overheat, resulting in damage to the furnace. Twinning is used to make two furnaces operate in tandem, using one duct system, one room thermostat and causing both furnaces to turn on and off simultaneously.

WARNING

Before installing the relay and wiring, disconnect electrical power to both furnaces. Failure to cut power could result in electrical shock or equipment damage.

CAUTION

The relay must not be installed in any location where it could be exposed to water. If the relay has been exposed to water in any way, it must not be used.

TWINNING DUCT SYSTEM

Twinning furnaces must only be applied on a common duct system. A single air supply plenum must be used for both furnaces and coil(s). Separate plenums and supply ducts systems cannot be utilized. A single return air plenum, common to both furnaces must be used. It is suggested that a return platform be utilized, with bottom air entrance into each furnace. If a side entrance returns system is used, the common return duct must be divided equally so as to supply each furnace with an equal amount of return air.

Both furnaces must be identical models in both heating capacity and CFM capacity. Both furnaces must be operated on the same motor speed tap. See typical application, Figure 11.

If furnace staging is desired with two single stage furnaces on a common duct, where the gas burner on the first furnace operates on W1 and the gas burner on the second furnace operates on W2, then the use of an air-mixing device in the plenum to mix the air from both furnaces is strongly recommended. The mixing device must be installed before any ducts that supply air to occupied spaces. Twinning causes both indoor fans to operate simultaneously. If a mixing device is not used, any ducts that are connected down stream from the furnace that operates on W2, will be supplying cold air in the Heating mode to the occupied spaces unless W2 is energized.

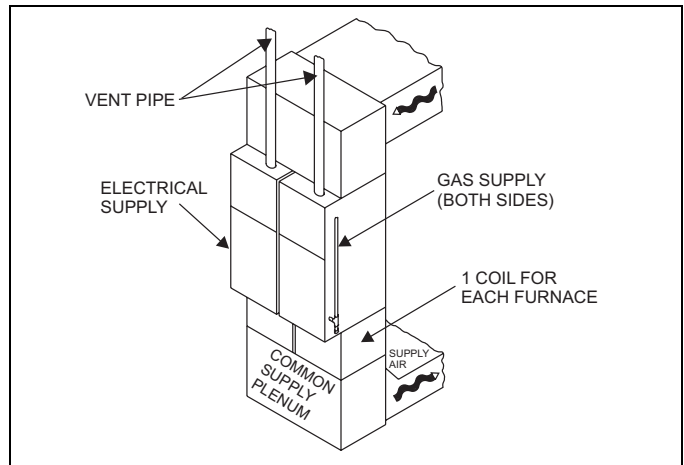

FIGURE 11: Typical Twinned Furnace Application

IMPORTANT: When two furnaces are twinned, typical system total airflow will be approximately 85% of additive individual furnaces, i.e., two 2000 CFM units will yield a total 3400 CFM.

CAUTION

If a return duct is connected to only one furnace (with a connection between the two furnaces) an imbalance in the airflow will occur and the furnace furthest from the return plenum will overheat.

GAS PIPING

Furnace gas supplies must be provided as specified with these instructions. Since the furnaces are side by side, with no space between, gas supplies must enter on the right and left respectively. All gas piping must be in accordance with the national fuel gas code, ANSI Z223.1, latest edition, and/or all local code or utility requirements.

TWINNING

In applications where more heating capacity or more airflow capacity is needed than what one furnace can deliver, twinning can be used to make two furnaces operate in tandem, using one duct system and one room thermostat. When one duct system is used for two furnaces, it is necessary that the two blowers operate in unison. The twinning function of the board in this furnace ensures that both blowers turn on and off simultaneously, and operate on the same blower speed.

Single-Wire Twinning

The control in the furnace has the single-wire twinning feature. With this feature, a single wire is connected between the TWIN terminal on one furnace board to the TWIN terminal on the second furnace board. The board then communicates the blower status from one furnace to the other along this wire. This communication makes the second furnace blower come on at the same time, and on the same speed, as the first furnace blower.

Single-Wire Twinning Instructions

Connect the control wiring as shown in Figure 12.

1. Connect the low voltage wiring from the wall thermostat to the terminal strip on the control board of Furnace #1.
2. Connect a wire from the TWIN terminal of Furnace #1 to the TWIN terminal of Furnace #2.
3. Install a separate 24V relay as shown in the diagram below. Use of this relay is required, as it ensures that the transformers of the two furnaces are isolated, thus preventing the possibility of any safety devices being bypassed.

Single-Wire Twinning Operation

Heating - On a call for heat (W signal) from the wall thermostat, both furnaces will start the ignition sequence and the burners on both furnaces will light. About thirty seconds after the burners light, the blowers on both furnaces will come on in heating speed. When the thermostat is satisfied, the burners will all shut off and, after the selected blower off delay time, both blowers will shut off at the same time. The twinning control ensures that both blowers come on and shut off at the same time.

Cooling - On a call for cooling (Y signal) from the wall thermostat, both furnace blowers will come on at the same time in cooling speed. When the thermostat is satisfied, both blowers will stay on for 60 seconds, then will shut off at the same time.

Continuous Fan - On a thermostat call for continuous fan (G signal), both furnace blowers will come on at the same time in cooling speed and will stay on until the G signal is removed.

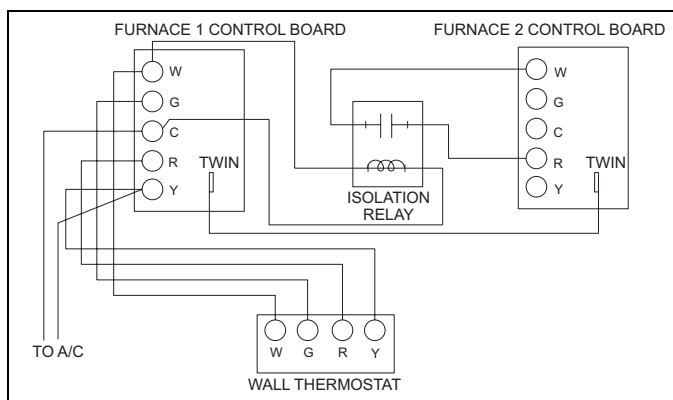

FIGURE 12: Single Stage Twinning Wiring Diagram

STAGING

In applications where more heating capacity or more airflow capacity is needed than what one furnace can deliver, twinning can be used to make two furnaces operate in tandem, using one duct system and one room thermostat. This control can also be used along with a two-stage wall thermostat to stage two twinned furnaces, making them operate like a single two-stage furnace. This allows only one furnace to supply heat during times when the heat output from one furnace is sufficient to satisfy the demand. When one duct system is used for two furnaces, it is necessary that the two blowers operate in unison. The twinning function of this board ensures that both blowers turn on and off simultaneously, and operate on the same blower speed. Even when only one furnace is supplying heat, both furnace blowers must run.

Single-Wire Staging

The single-wire twinning feature of this board can also be used for staging of two furnaces. With this feature, a single wire is connected between the TWIN terminal on one furnace board to the TWIN terminal on the second furnace board. The board then communicates the blower status from one furnace to the other along this wire. This communication makes the second furnace blower come on at the same time, and on the same speed, as the first furnace blower.

Single-Wire Staging Instructions

Connect the control wiring as shown in Figure 13.

1. Connect the low voltage wiring from the wall thermostat to the terminal strip on the control board of Furnace #1. For staging applications, the wire from thermostat W1 is connected to the W connection on the board on Furnace #1. The wire from thermostat W2 is connected to Furnace #2 through a separate relay, as described below.
2. Connect a wire from the TWIN terminal of Furnace #1 to the TWIN terminal of Furnace #2.
3. Install a separate 24V relay as shown in the diagram below. Use of this relay is required, as it ensures that the transformers of the two furnaces are isolated, thus preventing the possibility of any safety devices being bypassed.

Single-Wire Staging Operation

Heating - On a call for first-stage heat (W1 signal) from the wall thermostat, Furnace #1 will start the ignition sequence and the burners will light. About thirty seconds after the burners light, the blowers on both furnaces will come on in heating speed. When the thermostat is satisfied, the burners will shut off and, after the selected blower off delay time, both blowers will shut off at the same time. On a call for second stage of heat, the burners of Furnace #2 will also light and both blowers will run. The twinning control ensures that both blowers come on and shut off at the same time.

Cooling - On a call for cooling (Y signal) from the wall thermostat, both furnace blowers will come on at the same time. When the thermostat is satisfied, both blowers will stay on for 60 seconds, then will shut off at the same time.

Continuous Fan - On a thermostat call for continuous fan (G signal), both furnace blowers will come on at the same time in cooling speed and will stay on until the G signal is removed.

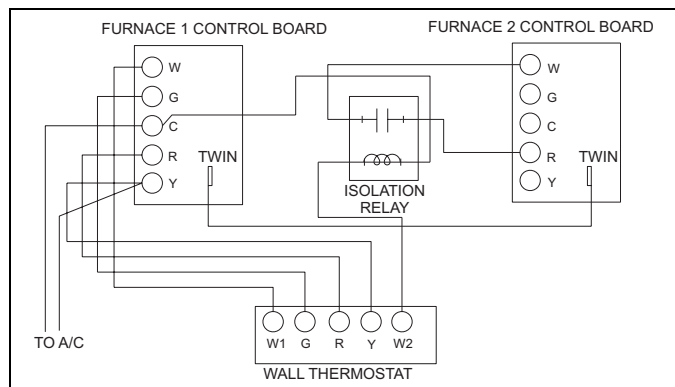

FIGURE 13: Two-Stage Twinning Wiring Diagram

SECTION VII: VENT SYSTEM

VENT SAFETY

This Category I, furnace is designed for residential application. It may be installed without modification in a basement, garage, equipment room, alcove, attic or any other indoor location where all required clearance to combustibles and other restrictions are met.

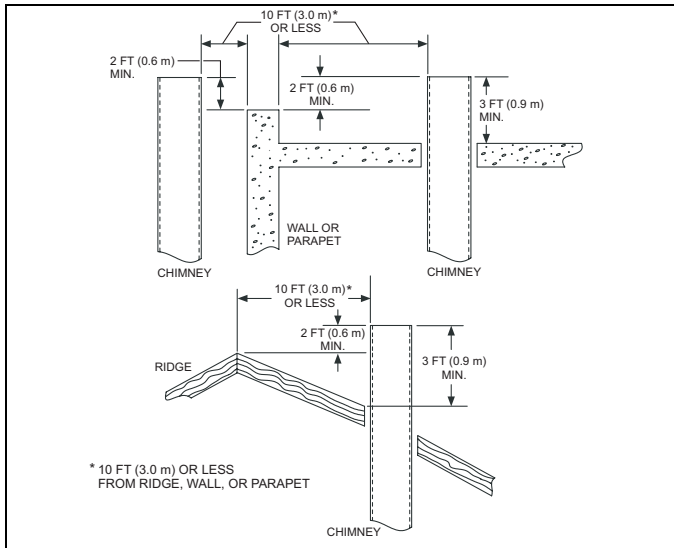

FIGURE 14: Vent Termination 10 ft. (3.0 m) or less

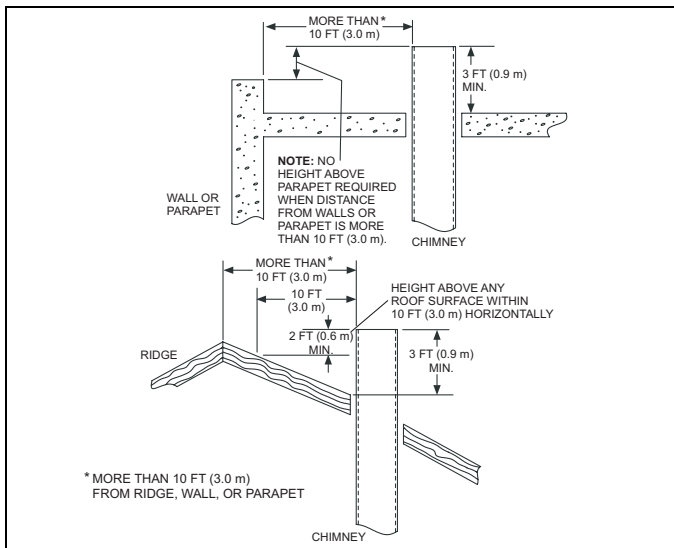

FIGURE 15: Vent Termination more than 10 ft. (3.0 m)

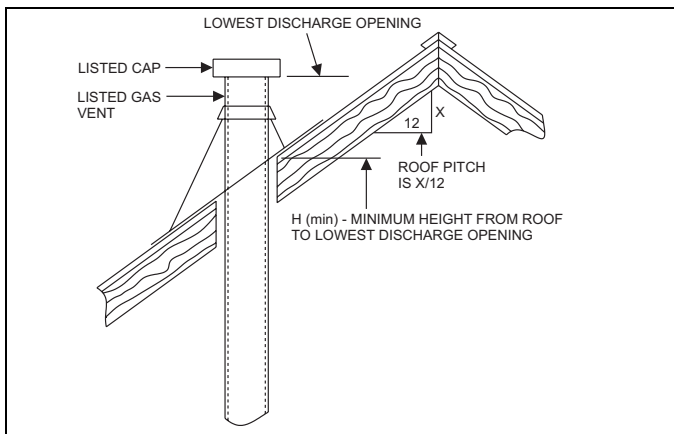

FIGURE 16: Vent Termination

TABLE 8: Roof Pitch

| ROOF PITCH | H(min) ft | m |
|---------------------|-----------|------|
| Flat to 6/12 | 1.0 | 0.30 |
| 6/12 to 7/12 | 1.25 | 0.38 |
| Over 7/12 to 8/12 | 1.5 | 0.46 |
| Over 8/12 to 9/12 | 2.0 | 0.61 |
| Over 9/12 to 10/12 | 2.5 | 0.76 |
| Over 10/12 to 11/12 | 3.25 | 0.99 |
| Over 11/12 to 12/12 | 4.0 | 1.22 |
| Over 12/12 to 14/12 | 5.0 | 1.52 |
| Over 14/12 to 16/12 | 6.0 | 1.83 |
| Over 16/12 to 18/12 | 7.0 | 2.13 |
| Over 18/12 to 20/12 | 7.5 | 2.27 |
| Over 20/12 to 21/12 | 8.0 | 2.44 |

CATEGORY 1 - 450 F. MAX. VENT TEMP.

The venting system must be installed in accordance with Section 5.3, Air for Combustion and Ventilation, of the National Fuel Gas Code Z223.1/NFPA 54 (latest edition), or Sections 7.2, 7.3 or 7.4 of CSA B149.1, National Gas and Propane Codes (latest edition) or applicable provisions of the local building code and these instructions.

The furnace shall be connected to any type of B, BW or L vent connector, and shall be connected to a factory-built or masonry chimney. **The furnace shall not be connected to a chimney flue serving a separate appliance designed to burn solid fuel.**

The furnace rating plate lists the maximum vent gas temperature. This temperature must be used to select the appropriate venting materials and clearances.

It is recommended that the appliance is installed in a location where the space temperature is 32 °F (0°C) or higher. If the appliance is installed in a location where the ambient temperature is below 32 °F (0°C), the combustion by-products could condense causing damage to the appliance heat exchanger.

IMPORTANT: The "VENT SYSTEM" must be installed as specified in these instructions for Residential and Modular Homes.

This appliance may be common vented with another gas appliance for residential installations as allowed by the codes and standards listed in these instructions.

Approved Modular Homes must be vented with an approved roof jack and may not be common vented with other appliances.

VENTING

Category I venting consists of vertically venting one or more appliances in B-vent or masonry chimney (as allowed), using single wall metal pipe or B-vent connectors. Type B-vent system extends in a general vertical direction and does not contain offsets exceeding 45 degrees. A vent system having not more than one 60 degree offset is permitted.

The vent system must be attached to the flue collar with a minimum of two (2) mechanical fasteners, such as screws or rivets. See Figure 20.

VENTING INTO AN EXISTING CHIMNEY

For Category I installations, the furnace shall be connected to a factory built chimney or vent complying with a recognized standard, or a masonry or concrete chimney lined with a material acceptable to the authority having jurisdiction. Venting into an unlined masonry chimney or concrete chimney is prohibited.

Whenever possible, B-1 metal pipe should be used for venting. Where use of an existing chimney is unavoidable, the following rules must be followed:

1. The masonry chimney must be built and installed in accordance with nationally recognized building codes or standards and must be lined with approved fire clay tile flue liners or other approved liner material that will resist corrosion, softening, or cracking from flue gases. **THIS FURNACE IS NOT TO BE VENTED INTO AN UNLINED MASONRY CHIMNEY.**

2. This furnace must be vented into a fire clay tile lined masonry chimney only if a source of dilution air is provided, such as by common venting with a draft hood equipped water heater. If no source of dilution air is available, Type B vent must be used, or masonry chimney vent kit 1CK0603 or 1CK0604 must be used. Refer to the instructions with the kit to properly apply these masonry chimney kits.
3. The chimney must extend at least three (3) ft (0.91 m) above the highest point where it passes through a roof of a building and at least two (2) feet higher than any portion of the building with a horizontal distance of ten (10) feet.
4. The chimney must extend at least five (5) ft (1.5 m) above the highest equipment draft hood or flue collar.

HORIZONTAL SIDEWALL VENTING

For applications where vertical venting is not possible, the only approved method of horizontal venting is the use of an auxiliary power vent. Approved power venters are Fields Controls Model SWG-4Y or the appropriate Tjernlund GPAK model. Follow all application and installation details provided by the manufacturer of the power vent. This unit may be horizontally vented using 4" (10.2 cm) diameter pipe with a minimum length of 4.5 feet (1.37 m) and a maximum length of 34.5 feet (10.82 m) with up to 4 elbows.

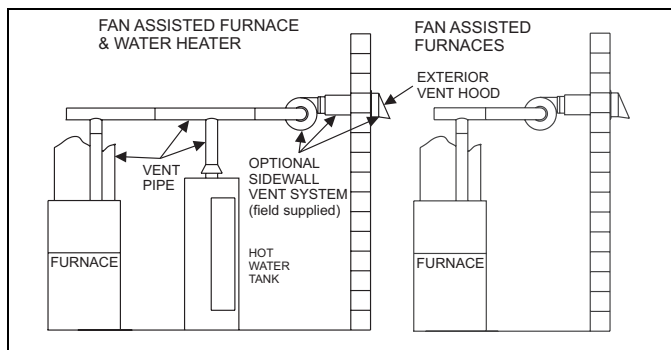

FIGURE 17: Typical Sidewall Vent Application

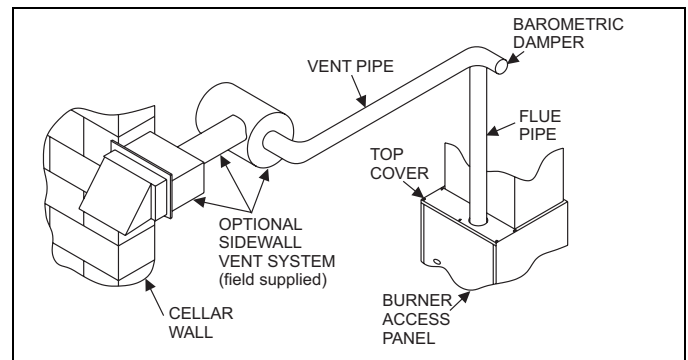

FIGURE 18: Typical Sidewall Vent and Termination Configuration

VENT PIPING ASSEMBLY

The final assembly procedure for the vent piping is as follows:

1. Cut piping to the proper length beginning at the furnace.
2. Deburr the piping inside and outside.
3. Dry-fit the vent piping assembly from the furnace to the termination checking for proper fit support and slope. Piping should be supported with pipe hangers to prevent sagging. The maximum spacing between hangers is 5 feet (1.5 m).
4. Assemble the vent piping from the furnace to the termination securing the pipe connections with screws.

VENT CLEARANCES

IMPORTANT: The vent must be installed with the following minimum clearances as shown in Figure 19, and must comply with local codes and requirements.

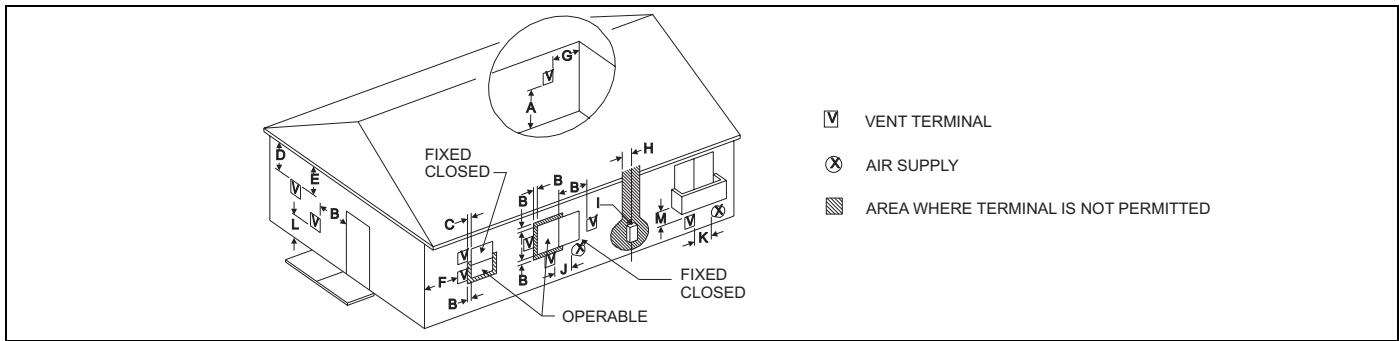

FIGURE 19: Home Layout

| | Canadian Installations ¹ | US Installation ² |
|---|--|---|
| A. Clearance above grade, veranda, porch, deck, or balcony | 12 inches (30 cm) | 12 inches (30 cm) |
| B. Clearance to window or door that may be opened | 12 inches (30 cm) for models <100,000 BTUH (30 kW), 36 inches (91 cm) for models > 100,000 BTUH (30 kW) | 4 Feet (1.22 m) |
| C. Clearance to permanently closed window | 12 inches (30 cm) | 12 inches (30 cm) |
| D. Vertical clearance to ventilated soffit located above the terminal within a horizontal distance of 2 feet (61 cm) from the center line of the terminal | 4 Feet (1.22 m) | 4 Feet (1.22 m) |
| E. Clearance to unventilated soffit | 12 Inches | 12 Inches |
| F. Clearance to outside corner | 12 Inches | 12 Inches |
| G. Clearance to inside corner | 6 feet (1.83 m) | 6 feet (1.83 m) |
| H. Clearance to each side of center line extended above meter/regulator assembly | 3 feet (91 cm) within a height 15 feet (4.5 m) above the meter/regulator assembly | 3 feet (91 cm) within a height 15 feet (4.5 m) above the meter/regulator assembly |
| I. Clearance to service regulator vent outlet | 3 feet (91 cm) | 3 feet (91 cm) |
| J. Clearance to nonmechanical air supply inlet to building or the combustion air inlet to any other appliance | 12 inches (30 cm) for models <100,000 BTUH (30 kW), 35 inches (91 cm) for models >100,000 BTUH (30 kW) | 4 Feet (1.22 m) |
| K. Clearance to a mechanical supply inlet | 6 feet (1.83 m) | 3 feet (91 cm) above if within 10 feet (3 cm) horizontally |
| L. Clearance above paved sidewalk or paved driveway located on public property | 7 feet (2.13 m) † | 7 feet (2.13 m) † |
| M. Clearance under veranda, porch, deck, or balcony | 12 inches (30.4 cm) | 12 inches (30.4 cm) |
| Vent Termination from any Building Surface | 12 inches (30.4 cm) | 12 inches (30.4 cm) |
| Above anticipated snow depth | 12 inches (30.4 cm) | 12 inches (30.4 cm) |

1. In accordance with the current CSA B149.1-00, Natural Gas and Propane Installation Code.
2. In accordance with the current ANSI Z223.1 / NFPA 54, National Gas Code.

† A vent shall not terminate directly above a sidewalk or paved driveway that is located between two single family dwellings and serves both dwellings.

‡ Permitted only if veranda, porch, deck, or balcony is fully open on a minimum of two sides beneath the floor. For clearance not specified in ANSI Z223.1 / NFPA 54 or CSA B149.1-00.

** Clearance in accordance with local installation codes and the requirements of the gas supplier and the manufacturer's Installation Manual.

Any fresh air or make up inlet for dryer or furnace area is considered to be forced air inlet.

Avoid areas where condensate drippage may cause problems such as above planters, patios, or adjacent to windows where steam may cause fogging.

A terminus of a vent shall be either:

Fitted with a cap in accordance with the vent manufacturer's installation instructions, or In accordance with the installation instructions for a special venting system.

IMPORTANT: Consideration must be given for degradation of building materials by flue gases. Sidewall termination may require sealing or shielding of building surfaces with a corrosion resistant material to protect against combustion product corrosion. Consideration must be given to wind direction in order to prevent flue products and/or condensate from being blown against the building surfaces. If a metal shield is used it must be a stainless steel material at a minimum dimension of 20 inches. It is recommended that a retaining type collar be used that is attached to the building surface to prevent movement of the vent pipe.

Responsibility for the provision of proper adequate venting and air supply for application shall rest with the installer.

Vent shall extend high enough above building, or a neighboring obstruction, so that wind from any direction will not create a positive pressure in the vicinity of the vent.

HORIZONTAL VENT APPLICATIONS AND TERMINATION

When selecting the location for a horizontal combustion air / vent termination, the following should be considered:

1. Observe all clearances listed in vent clearances in these instructions.
2. Termination should be positioned where vent vapors will not damage plants or shrubs or air conditioning equipment.
3. Termination should be located where it will not be affected by wind gusts, light snow, airborne leaves or allow recirculation of flue gases.
4. Termination should be located where it will not be damaged or exposed to flying stones, balls, etc.
5. Termination should be positioned where vent vapors are not objectionable.

6. Horizontal portions of the vent system must slope upwards and be supported to prevent sagging. The vent system may be supported by the use of clamps or hangers secured to a permanent part of the structure every four (4) ft. (1.22 m).

FAN-ASSISTED COMBUSTION SYSTEM

This appliance is equipped with an integral mechanical means to draw products of combustion through the heat exchanger.

Ambient Combustion Air Supply

This type installation will draw the air required for combustion from within the space surrounding the appliance and from areas or rooms adjacent to the space surrounding the appliance. This may be from within the space in a non-confined location or it may be brought into the furnace area from outdoors through permanent openings or ducts. A properly sized duct from the outside to the furnace location must be provided.

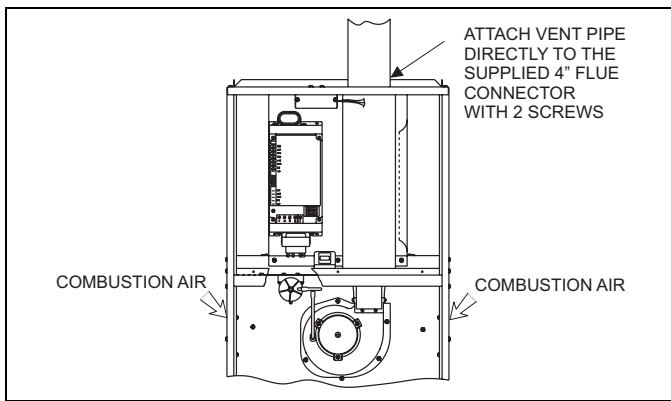

FIGURE 20: Combustion Airflow Path Through The Furnace Casing

WARNING

This type of installation requires that the supply air to the appliance(s) be of a sufficient amount to support all of the appliance(s) in the area. Operation of a mechanical exhaust, such as an exhaust fan, kitchen ventilation system, clothes dryer or fireplace may create conditions requiring special attention to avoid unsatisfactory operation of gas appliances. A venting problem or a lack of supply air will result in a hazardous condition, which can cause the appliance to soot and generate dangerous levels of CARBON MONOXIDE, which can lead to serious injury, property damage and / or death.

An **unconfined space** is not less than 50 cu.ft (1.42 m³) per 1,000 Btu/hr. (0.2928 kW) input rating for all of the appliances installed in that area.

Rooms communicating directly with the space containing the appliances are considered part of the unconfined space, if openings are not furnished with doors.

A **confined space** is an area with less than 50 cu.ft (1.42 m³) per 1,000 Btu/hr. (0.2928 kW) input rating for all of the appliances installed in that area. The following must be considered to obtain proper air for combustion and ventilation in confined spaces.

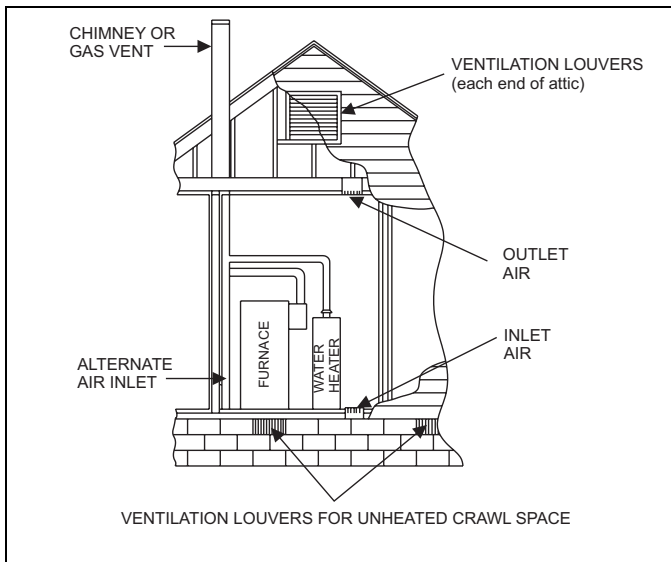

FIGURE 21: Alternate Air Intake, Air Outlet and Chimney Connections

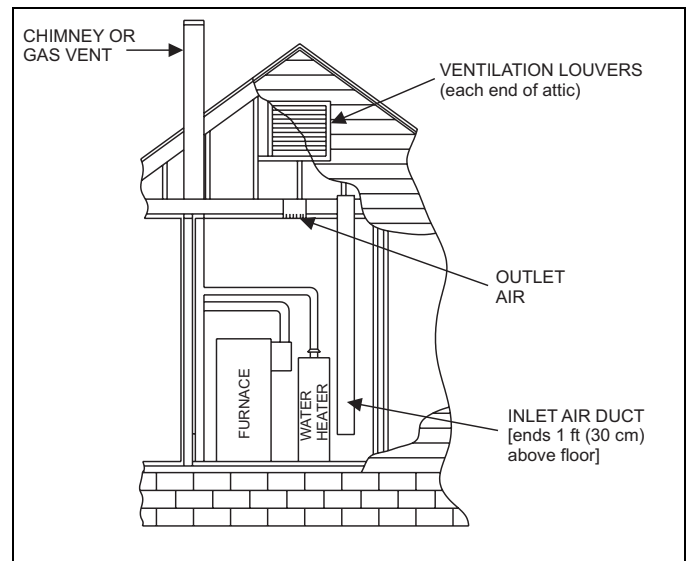

FIGURE 22: Air Inlet, Outlet and Chimney Connections

Combustion Air Source From Outdoors

The blocking effects of louvers, grilles and screens must be given consideration in calculating free area. If the free area of a specific louver or grille is not known, refer to Table 9, to estimate free area.

TABLE 9: Estimated Free Area

| | |
|----------------------------------|-------------------------------------|
| Wood or Metal Louvers or Grilles | Wood 20-25%* Metal 60-70% * |
| Screens+ | 1/4" (0.635 cm) mesh or larger 100% |

+ Do not use less than 1/4" (0.635 cm) mesh

* Free area of louvers and grille varies widely; the installer should follow louver or grille manufacturer's instructions.

Dampers, Louvers and Grilles (Canada Only)

1. The free area of a supply air opening shall be calculated by subtracting the blockage area of all fixed louvers, grilles or screens from the gross area of the opening.
2. Apertures in a fixed louver, grille, or screen shall have no dimension smaller than 0.25" (0.64 cm).
3. A manually operated damper or manually adjustable louvers are not permitted for use.
4. An automatically operated damper or automatically adjustable louvers shall be interlocked so that the main burner cannot operate unless either the damper or the louver is in the fully open position.

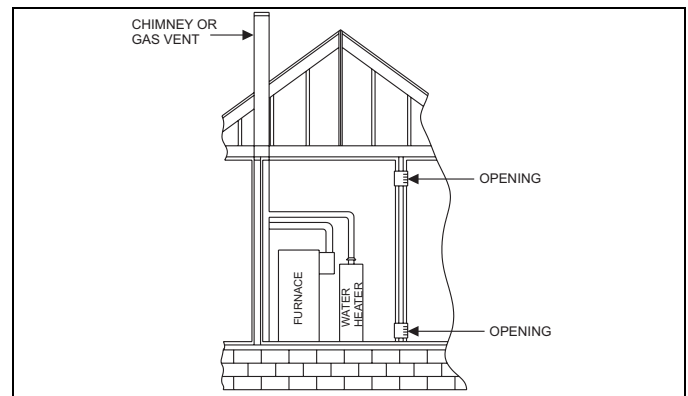

FIGURE 23: Typical Chimney Connections

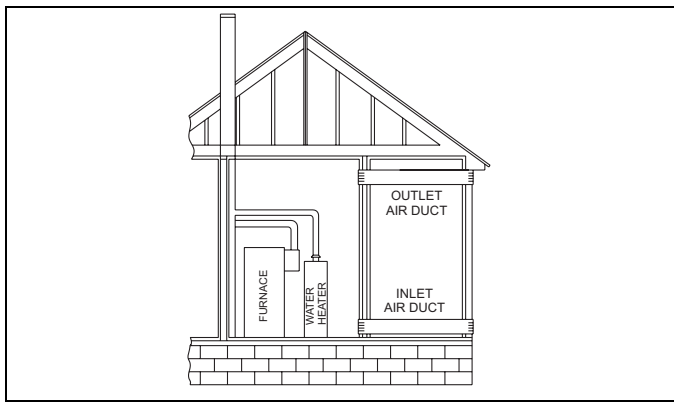

FIGURE 24: Horizontal Air Inlet, Outlet and Chimney Connections

TABLE 10: Unconfined Space Minimum Area in Square Inch

| BTUH Input Rating | Minimum Free Area in Square Inches Required for Each Opening (50 ft. ³ / 1000 BTUH) |
|-------------------|--|
| 40,000 | 40 (258 cm ²) |
| 60,000 | 60 (387 cm ²) |
| 80,000 | 80 (516 cm ²) |
| 100,000 | 100 (645 cm ²) |
| 115,000 | 115 (742 cm ²) |
| 130,000 | 130 (838 cm ²) |

TABLE 11: Free Area

| Combined BTUH Input Rating For All Appliances | Minimum Free Area Required for Each Opening | | |
|---|---|--|-----------------------------------|
| | Horizontal Duct (2,000 BTUH / Sq. In.) | Vertical Duct or Opening to Outside (4,000 BTUH / Sq. In.) | Round Duct (4,000 BTUH / Sq. In.) |
| 40,000 | 20 in ² (129 cm ²) | 10 in ² (64 cm ²) | 4" (10 cm) |
| 60,000 | 30 in ² (193 cm ²) | 15 in ² (97 cm ²) | 5" (13 cm) |
| 80,000 | 40 in ² (258 cm ²) | 20 in ² (129 cm ²) | 5" (13 cm) |
| 100,000 | 50 in ² (322 cm ²) | 25 in ² (161 cm ²) | 6" (15 cm) |
| 150,000 | 60 in ² (387 cm ²) | 30 in ² (193 cm ²) | 7" (18 cm) |
| 130,000 | 65 in ² (419 cm ²) | 33 in ² (213 cm ²) | 7" (18 cm) |

EXAMPLE: Determining Free Area - Vertical Minimum Duct Size

Appliance 1 Appliance 2 Total Input
100,000 + 30,000 = 130,000 ÷ 4,000 = 32.5 Sq. In.

EXAMPLE: Determining Free Area - Horizontal Minimum Duct Size

Appliance 1 Appliance 2 Total Input
100,000 + 30,000 = 130,000 ÷ 2,000 = 65 Sq. In.

WARNING

When a Category I furnace is removed or replaced, the original venting system may no longer be correctly sized to properly vent the attached appliances. An improperly sized vent system can cause CARBON MONOXIDE to spill into the living space causing personal injury, and or death.

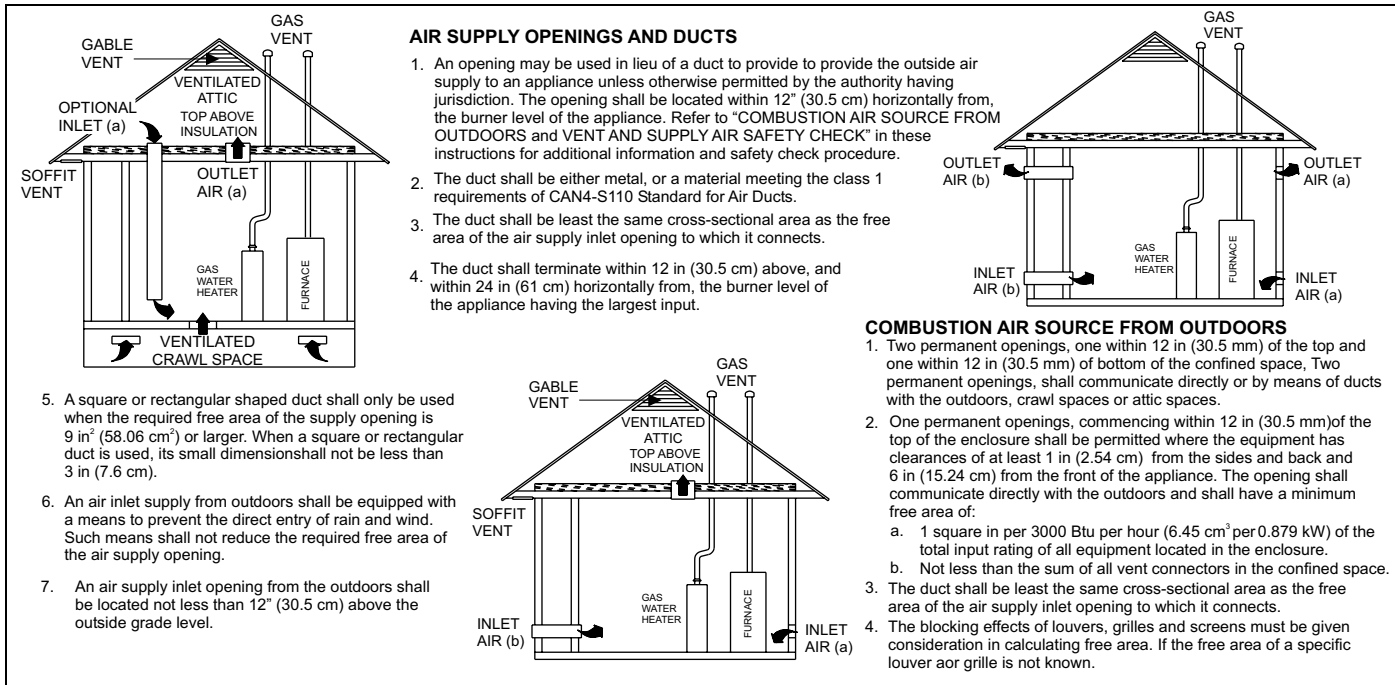

FIGURE 25: Outside and Ambient Combustion Air

Ventilated Combustion Air

The ventilated attic space or a crawl space from which the combustion air is taken must comply with the requirements specified in "AIR SOURCE FROM OUTDOORS" in this instruction or in Section 5.3, Air for Combustion and Ventilation of the National Fuel Gas Code, ANSI Z223.1 (latest edition). This type installation requires two (2) properly sized pipes. One brings combustion air from a properly ventilated attic space or crawl space and a second pipe that extends from the furnace vent connection (top right of unit) to the exterior of the building. Follow all notes, procedures and required materials in the SEALED COMBUS-

TION AIR SUPPLY section in these instructions when installing the combustion air pipe from the unit and into a ventilated attic space or crawl space. DO NOT terminate vent pipe in an attic or crawl space.

Vent and Supply (Outside) Air Safety Check Procedure

For Category I furnaces, vent installations shall be in accordance with Parts 7 and 11 of the National Fuel Gas Code, ANSI Z223.1/NFPA 54, and or Section 7 and Appendix B of the CSA B149.1, Natural Gas and Propane Installation Codes, the local building codes, furnace and vent manufacturer's instructions.

Multi-story or common venting systems are permitted and must be installed in accordance with the National Fuel Gas Code, ANSI Z223.1/NFPA 54 and / or the CSA B149.1, Natural Gas and Propane Installation Codes, local codes, and the manufacturer's instructions.

Vent connectors serving Category I furnaces shall not be connected into any portion of mechanical draft systems operating under positive pressure.

Horizontal portions of the venting system shall be supported to prevent sagging using hangers or perforated straps and must slope upwards not less than 1/4" per foot (0.635 cm/m) from the furnace to the vent terminal.

It is recommended that you follow the venting safety procedure below. This procedure is designed to detect an inadequate ventilation system that can cause the appliances in the area to operate improperly causing unsafe levels of Carbon Monoxide or an unsafe condition to occur.

▲ WARNING

CARBON MONOXIDE POISONING HAZARD

Failure to follow the steps outlined below for each appliance connected to the venting system being placed into operation could result in carbon monoxide poisoning or death.

The following steps shall be followed for each appliance connected to the venting system being placed into operation, while all other appliances connected to the venting system are not in operation:

1. Seal any unused openings in the venting system.
2. Inspect the venting system for proper size and horizontal pitch, as required in the National Fuel Gas Code, ANSI Z223.1/NFPA 54 or the CSA B149.1, Natural Gas and Propane Installation Code and these instructions. Determine that there is not blockage or restriction, leakage, corrosion and other deficiencies which could cause an unsafe condition.
3. As far as practical, close all building doors and windows and all doors between the space in which the appliance(s) connected to the venting system are located and other spaces of the building.
4. Close fireplace dampers.
5. Turn on clothes dryers and any appliance not connected to the venting system. Turn on any exhaust fans, such as range hoods and bathroom exhausts, so they are operating at maximum speed. Do not operate a summer exhaust fan.
6. Follow the lighting instructions. Place the appliance being inspected into operation. Adjust the thermostat so appliance is operating continuously.
7. Test for spillage from draft hood equipped appliances at the draft hood relief opening after 5 minutes of main burner operation. Use the flame of a match or candle.
8. If improper venting is observed during any of the above tests, the venting system must be corrected in accordance with the National Fuel Gas Code, ANSI Z223.1/NFPA 54 and/or CSA B149.1, Natural Gas and Propane Installation Code.
9. After it has been determined that each appliance connected to the venting system properly vents when tested as outlined above, return doors, windows, exhaust fans, fireplace dampers and any other gas-fired burning appliance to their previous conditions of use.

SECTION VIII: SAFETY CONTROLS

CONTROL CIRCUIT FUSE

A 3-amp fuse is provided on the control circuit board to protect the 24-volt transformer from overload caused by control circuit wiring errors. This is an ATO 3, automotive type fuse and is located on the control board.

BLOWER DOOR SAFETY SWITCH

This unit is equipped with an electrical interlock switch mounted in the blower compartment. This switch interrupts all power at the unit when the panel covering the blower compartment is removed.

Electrical supply to this unit is dependent upon the panel that covers the blower compartment being in place and properly positioned.

▲ CAUTION

Main power to the unit must still be interrupted at the main power disconnect switch before any service or repair work is to be done to the unit. Do not rely upon the interlock switch as a main power disconnect.

Blower and burner must never be operated without the blower panel in place.

ROLLOUT SWITCH CONTROLS

These controls are mounted on the burner assembly. If the temperature around the burners exceed the set point, the ignition control and the gas valve are de-energized. The operation of this control indicates a malfunction in the combustion air blower, heat exchanger or a blocked vent pipe connection. Corrective action is required. These are manual reset controls that must be reset before operation can continue.

PRESSURE SWITCHES

This furnace is supplied with a pressure switch which monitors the flow through the combustion air/vent piping system. This switch de-energizes the ignition control module and the gas valve if any of the following conditions are present. Refer to Figure 26 for tubing connections.

1. Blockage of vent piping or terminal.
2. Failure of combustion air blower motor.

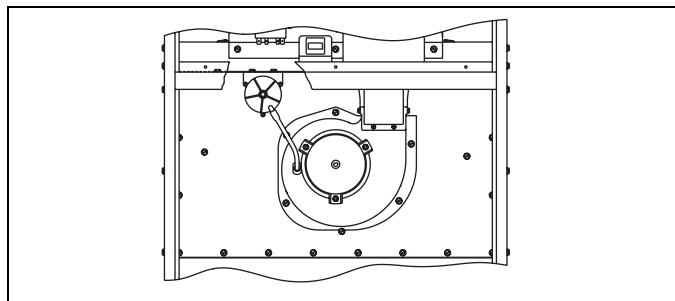

FIGURE 26: Pressure Switch Tubing Routing

LIMIT CONTROLS

There is a high temperature limit control located on the furnace vestibule panel near the gas valve. This is an automatic reset control that provides over temperature protection due to reduced airflow. This may be caused by:

1. Dirty filter.
2. If the indoor fan motor should fail.
3. Too many supply or return registers closed or blocked off.

The control module will lockout if the limit trips five (5) consecutive times. Control will reset and try again after one 1 hour.

SECTION IX: START-UP AND ADJUSTMENTS

The initial start-up of the furnace requires the following additional procedures:

IMPORTANT: All electrical connections made in the field and in the factory should be checked for proper tightness.

When the gas supply is initially connected to the furnace, the gas piping may be full of air. In order to purge this air, it is recommended that the ground union be loosened until the odor of gas is detected. When gas is detected, immediately re-tighten the union and check for leaks. Allow five (5) minutes for any gas to dissipate before continuing with the start-up procedure. Be sure proper ventilation is available to dilute and carry away any vented gas.

NOx SCREEN REMOVAL (Lo-NOx Models Only)

If the furnace is equipped with NOx screens and is to be used with LP (propane) gas, the screens must be removed prior to start-up.

1. Make sure that the electrical power to the unit is turned off and that the gas supply is turned off at the shut-off valve.
2. Remove the blower compartment and burner compartment access doors.
3. Disconnect the gas supply piping at the union to permit removal of the entire burner and gas control assembly from the vestibule panel. Use the wrench boss on the gas valve when removing or installing the piping.
4. Unplug the igniter from the wire harness. Disconnect the flame sensor wires located on top of the air shield. Unplug the gas valve from the wiring harness.
5. Remove the igniter and igniter bracket. Handle the igniter very carefully since it is fragile and easily broken.
6. Remove the screws holding the burner assembly to the vestibule panel. It may be necessary to remove the rollout switch bracket(s) to gain access to one or more of these screws.
7. Remove the burner assembly. It should be possible to swing the burner assembly out of the way without disconnecting the remaining wires.
8. With the burner assembly out of the way, simply slide the NOx screens out of the heat exchanger tubes and discard the screens.
9. Replace all components in reverse order. Reconnect all wiring.

TOOLS AND INFORMATION THAT WILL BE REQUIRED IN ORDER TO PROPERLY PERFORM THE FURNACE START-UP PROCEDURE.

1. Call the local gas supplier to obtain heating value of the natural gas. If you cannot obtain the heating value of the gas from the gas supplier, you may use a default value of 1030 BTU/SCF (38.8 MJ/m³).
2. You will need a thermometer or portable digital thermometer to read the supply and return air temperatures.
3. You will need a U-tube manometer or digital equipment that has the ability to read pressures between 0 – 15" in.w.c (0 - 3.73 kPa) in order to measure the gas line and the manifold pressures.
4. You will need a 3/32" Allen wrench for the pressure port plugs in the gas valve.
5. You will need 2 pieces of 1/8" (0.3 cm) ID flexible tubing that is 12" (30 cm) in length, 2 – pieces of 1/8" (0.3 cm) tubing that are 4" (10.0 cm) in length, a 1/8" (0.3 cm) tee and a 1/8" (0.3 cm) adapter to connect the U-tube manometer or the digital pressure measuring equipment to the gas valve pressure ports.

There is an accessory kit (1PK0601) available from Source 1, which has the following items:

- 1 – 12" (30 cm) length x 1/8" (0.3 cm) diameter tubing

- 2 – pieces of 4" (10 cm) length x 1/8" (0.3 cm) diameter tubing
- 1 – 5/16" (0.8 cm) tee
- 1 – 5/16" (0.8 cm) x 1/8" (3.175 mm) reducing coupling
- 1 – 1/8" (0.3 cm) adapter

There is an accessory kit (1PK0602) available from Source 1, which has the following items:

- 12" (30 cm) length x 1/8" (0.3 cm) diameter tubing
- 2 – pieces of 4" (10 cm) length x 1/8" (0.3 cm) diameter tubing
- 1 – 5/16" (0.8 cm) tee
- 1 – 5/16" (0.8 cm) x 1/8" (0.3 cm) reducing coupling
- 1 – 1/8" (0.3 cm) adapter
- 1 – Dwyer – Manometer

These items are required in order to properly perform the required start-up procedure.

IGNITION SYSTEM SEQUENCE

1. Turn the gas supply ON at external valve and main gas valve.
2. Set the thermostat above room temperature to call for heat.
3. System start-up will occur as follows:
 - a. The induced draft blower motor will start and come up to speed. Shortly after inducer start-up, the hot surface igniter will glow for about 17 seconds.
 - b. After this warm up, the ignition module will energize (open) the main gas valve.
 - c. After flame is established, the supply air blower will start in about 30 seconds.

WARNING

FIRE OR EXPLOSION HAZARD

Failure to follow the safety warnings exactly could result in serious injury, death or property damage.

Never test for gas leaks with an open flame. Use a commercially available soap solution made specifically for the detection of leaks to check all connections. A fire or explosion may result causing property damage, personal injury or loss of life.

IMPORTANT: Burner ignition may not be satisfactory on first start-up due to residual air in the gas line or until gas manifold pressure is adjusted. The ignition control will make three (3) attempts to light before locking out.

With furnace in operation, check all of the pipe joints, gas valve connections and manual valve connections for leakage using an approved gas detector, a non-corrosive leak detection fluid, or other leak detection methods. Take appropriate steps to stop any leak. If a leak persists, replace the component.

The furnace and its equipment shut-off valve must be disconnected from the gas supply piping system during any pressure testing of that system at test pressures in excess of 1/2 PSI (3.45 kPa).

CALCULATING THE FURNACE INPUT (NATURAL GAS)

NOTE: Burner orifices are sized to provide proper input rate using natural gas with a heating value of 1030 BTU/Ft³ (38.4 MJ/m³). If the heating value of your gas is significantly different, it may be necessary to replace the orifices.

NOTE: Front door of burner box must be secured when checking gas input.

1. Turn off all other gas appliances connected to the gas meter.
2. At the gas meter, measure the time (with a stop watch) it takes to use 2 cubic ft. (0.0566 m³.) of gas.
3. Calculate the furnace input by using one of the following equations.

In the USA use the following formula to calculate the furnace input.

For natural gas multiply the heat content of the gas BTU/SCF or Default 1030 BTU/SCF (38.4 MJ/m³), times 2 cubic ft. (0.056 m) of gas measured at the gas meter, times a barometric pressure and temperature correction factor of 0.960; times 3600, then divided by the time (In seconds) it took to measure 2 cubic ft. (0.056 m) of gas from the gas meter.

For propane (LP) gas multiply the heat content of the gas BTU/SCF or Default 2500 BTU/SCF (93.15 MJ/m³), times 1 cubic ft. (0.028 m) of gas measured at the gas meter, times a barometric pressure and temperature correction factor of 0.960; times 3600, then divided by the time (In seconds) it took to measure 1 cubic ft. (0.028 m) of gas from the gas meter.

The formula for US input calculation using a cubic foot gas meter:

| | | | | | |
|--|---|-----------|--|---|-----------|
| $\frac{\text{BTU/ft}^3 \times 2 \text{ cu.ft.} \times 0.960 \times 3600}{\text{Seconds it took to measure the 2 cu.ft. of gas}}$ | = | BTU/H | $\frac{\text{BTU/ft}^3 \times 1 \text{ cu.ft.} \times 0.960 \times 3600}{\text{Seconds it took to measure the 1 cu.ft. of gas}}$ | = | BTU/H |
| NATURAL GAS INPUT CALCULATION | | | PROPANE (LP) GAS INPUT CALCULATION | | |
| EXAMPLE: | | | EXAMPLE: | | |
| $\frac{1030 \times 2 \times 0.960 \times 3600}{90.5}$ | = | 78,666.90 | $\frac{2500 \times 1 \times 0.960 \times 3600}{108}$ | = | 80,000.00 |
| Natural Gas | | | Propane Gas | | |
| 1030 BTU/SCF | | | 2500 BTU/SCF | | |

In Canada you will use the following formula to calculate the furnace input if you are using a cubic foot gas meter.

For Natural Gas multiply the Heat content of the gas MJ/m³ (or Default 38.4), times 2 cubic ft. of gas x 0.028 to convert from cubic feet to cubic meters measured at the gas meter, times a barometric pressure and temperature correction factor of 0.960; times 3600, then divided by the time it took to measure 2 cubic ft. (0.056 m) of gas from the gas meter.

For Propane (LP) Gas multiply the Heat content of the gas MJ/m³ (or Default 93.15), times 1 cu. ft. of gas x 0.028 to convert from cubic feet to cubic meters measured at the gas meter, times a barometric pressure and temperature correction factor of 0.960; times 3600, then divided by the time it took to measure 1 cubic ft. (0.028 m) of gas from the gas meter.

The formula for metric input calculation using a cubic foot gas meter:

| | | | | | | | | | | |
|---|---|-------|---|--------|---|-------|---|---------|---|-----------|
| $\frac{\text{MJ/m}^3 \times 2 \text{ cu.ft.} \times 0.028 \times 0.960 \times 3600}{\text{Seconds it took to measure the 2 cu.ft. of gas}}$ | = | MJ/H | x | 0.2777 | = | kW | x | 3412.14 | = | BTU/H |
| NATURAL GAS INPUT CALCULATION | | | | | | | | | | |
| EXAMPLE: | | | | | | | | | | |
| $\frac{38.4 \times 2 \times 0.028 \times 0.960 \times 3600}{90.5}$ | = | 82.12 | x | 0.2777 | = | 22.80 | x | 3412.14 | = | 77,796.80 |
| Natural Gas | | | | | | | | | | |
| 1030 BTU/SCF = 38.4 MJ/m ³ | | | | | | | | | | |
| PROPANE (LP) GAS INPUT CALCULATION | | | | | | | | | | |
| EXAMPLE: | | | | | | | | | | |
| $\frac{93.15 \times 1 \times 0.028 \times 0.960 \times 3600}{108}$ | = | 83.46 | x | 0.2777 | = | 23.18 | x | 3412.14 | = | 79,093.4 |
| Propane Gas | | | | | | | | | | |
| 2500 BTU/SCF = 93.15 MJ/m ³ | | | | | | | | | | |

In Canada use the following formula to calculate the furnace input if you are using a gas meter that measures cubic meters.

For Natural Gas multiply the Heat content of the gas MJ/m³ (or Default 38.4), times 0.10 m³ of gas measured at the gas meter, times a barometric pressure and temperature correction factor of 0.960; times 3600, then divided by the time it took to measure 0.10 m³ of gas from the gas meter.

For Propane (LP) Gas multiply the Heat content of the gas MJ/m³ (or Default 93.15), times 0.10 m³ of gas measured at the gas meter, times a barometric pressure and temperature correction factor of 0.960; times 3600, then divided by the time it took to measure 0.10 m³ of gas from the gas meter.

The formula for metric input calculation using a cubic meter gas meter:

| | | | | | | | | | | |
|--|---|-------|---|--------|---|-------|---|---------|---|-----------|
| $\frac{\text{MJ/m}^3 \times \text{m}^3 \times 0.960 \times 3600}{\text{Seconds it took to measure the 0.10 m}^3 \text{ of gas}}$ | = | MJ/H | x | 0.2777 | = | kW | x | 3412.14 | = | BTU/H |
| NATURAL GAS INPUT CALCULATION | | | | | | | | | | |
| EXAMPLE: | | | | | | | | | | |
| $\frac{38.4 \times 0.1 \times 0.960 \times 3600}{160}$ | = | 82.94 | x | 0.2777 | = | 23.03 | x | 3412.14 | = | 78,581.60 |
| Natural Gas | | | | | | | | | | |
| 1030 BTU/SCF = 38.4 MJ/m ³ | | | | | | | | | | |
| PROPANE (LP) GAS INPUT CALCULATION | | | | | | | | | | |
| EXAMPLE: | | | | | | | | | | |
| $\frac{93.15 \times 0.1 \times 0.960 \times 3600}{387}$ | = | 83.19 | x | 0.2777 | = | 23.10 | x | 3412.14 | = | 78,826.3 |
| Propane Gas | | | | | | | | | | |
| 2500 BTU/SCF = 93.15 MJ/m ³ | | | | | | | | | | |

DO NOT ADJUST the manifold pressure regulator if the actual input is equal to or within 8% less than the furnace input specified on the rating plate or if the furnace rise is above the specified rise range on the rating plate.

If the actual input is significantly higher than the furnace input specified on the rating plate then replace the gas orifices with the gas orifices of the proper size for the type of gas you are using.

CAUTION

Be sure to relight any gas appliances that were turned off at the start of this input check.

ADJUSTMENT OF MANIFOLD GAS PRESSURE

Inlet and manifold gas pressure may be measured by connecting the "U" tube manometer to the gas valve with a piece of tubing. Follow the appropriate section in the instructions below. Refer to Figure 27 for a drawing of the locations of the pressure ports on the gas valve.

Turn gas off at the ball valve or gas cock on gas supply line before the gas valve. Find the pressure ports on the gas valve marked OUT P and IN P.

1. The manifold pressure must be taken at the port marked OUT P.
2. The gas line pressure must be taken at the port marked IN P.
3. Using a 3/32" (2.4 mm) Allen wrench, loosen the set screw by turning it one (1) turn counter clockwise. **DO NOT REMOVE THE SET SCREW FROM THE PRESSURE PORT.**

Read the inlet gas pressure

Connect the positive side of the manometer to the IN P Tap on the gas valve. Do not connect any tubing to the negative side of the manometer, as it will reference atmospheric pressure. Refer to Figure 28 for connection details.

1. Turn gas and electrical supplies on and follow the operating instructions to place the unit back in operation.

TABLE 12: Inlet Gas Pressure Range

| INLET GAS PRESSURE RANGE | | |
|--------------------------|-----------------------|-----------------------|
| | Natural Gas | Propane (LP) |
| Minimum | 4.5" W.C. (1.12 kPa) | 8.0" W.C. (1.99 kPa) |
| Maximum | 10.5" W.C. (2.61 kPa) | 13.0" (3.24 kPa) W.C. |

IMPORTANT: The inlet gas pressure operating range table specifies what the minimum and maximum gas line pressures must be for the furnace to operate safely. The gas line pressure **MUST BE** a minimum of

- 7" W.C. (1.74 kPa) for Natural Gas
- 11" W.C. (2.74 kPa) for Propane (LP) Gas

In order to obtain the BTU input specified on the rating plate and/or the nominal manifold pressure specified in these instructions and on the rating plate.

2. Once the correct gas inlet pressure has been established, see Table 12, turn the gas valve to OFF and turn the electrical supply switch to OFF; then remove the flexible tubing from the gas valve pressure tap and tighten the pressure tap plug using the 3/32" (2.4 mm) allen wrench.
3. Turn the electrical and gas supplies back on, and with the burners in operation, check for gas leakage around the gas valve pressure port for leakage using an approved non-corrosive gas leak detection fluid, or other non-flammable leak detection method.

Read the manifold gas pressure

Connect the positive side of the manometer to the OUT P Tap on the gas valve. Do not connect any tubing to the negative side of the manometer, as it will reference atmospheric pressure. Refer to Figure 28 for connection details.

IMPORTANT: The cap for the pressure regulator must be removed entirely to gain access to the adjustment screw. Loosening or tightening the cap does not adjust the flow of gas.

NOTE: The regulated outlet pressures, both low and high, have been calibrated at the factory. Additional pressure adjustment should not be necessary. If adjustment is necessary, set to the following specifications. After adjustment, check for gas leakage.

1. Refer to Figure 27 for location of pressure regulator adjustment cap and adjustment screws on main gas valve.

2. Turn gas and electrical supplies on and follow the operating instructions to place the unit back in operation.
3. Adjust manifold pressure by adjusting gas valve regulator screw for the appropriate gas per the following:

TABLE 13: Nominal Manifold Pressure

| NOMINAL MANIFOLD PRESSURE | |
|---------------------------|------------------------|
| Natural Gas | 3.5" w.c. (0.87 kPa) |
| Propane (LP) Gas | 10.0" w.c. (2.488 kPa) |

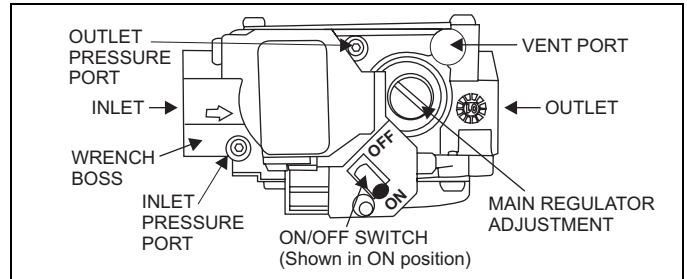

FIGURE 27: Gas Valve

IMPORTANT: If gas valve regulator is turned in (clockwise), manifold pressure is increased. If screw is turned out (counter clockwise), manifold pressure will decrease.

4. After the manifold pressure has been adjusted, re-calculate the furnace input to make sure you have not exceeded the specified input on the rating plate. Refer to "CALCULATING THE FURNACE INPUT (NATURAL GAS)".
5. Once the correct BTU (kW) input has been established, turn the gas valve to OFF and turn the electrical supply switch to OFF; then remove the flexible tubing from the gas valve pressure tap and tighten the pressure tap plug using the 3/32" (2.4 mm) Allen wrench.
6. Turn the electrical and gas supplies back on, and with the burners in operation, check for gas leakage around the gas valve pressure port for leakage using an approved non-corrosive gas leak detection fluid, or other non-flammable leak detection method.

WARNING

The manifold pressure must be checked with the screw-off cap for the gas valve pressure regulator in place. If not, the manifold pressure setting could result in an over-fire condition. A high manifold pressure will cause an over-fire condition, which could cause premature heat exchanger failure. If the manifold pressure is too low, sooting and eventual clogging of the heat exchanger could occur. Be sure that gas valve regulator cap is in place and burner box to gas valve pressure reference hose is connected.

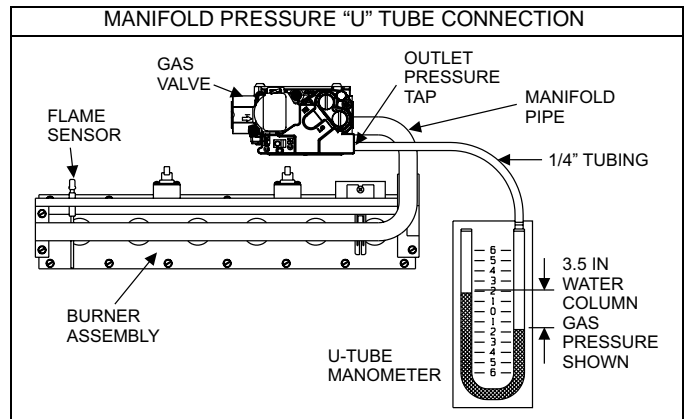

FIGURE 28: Reading Gas Pressure

ADJUSTMENT OF TEMPERATURE RISE

▲ DANGER

The temperature rise, or temperature difference between the return air and the supply (heated) air from the furnace, must be within the range shown on the furnace rating plate and within the application limitations shown in Table 7 "RATINGS & PHYSICAL/ELECTRICAL DATA".

The supply air temperature cannot exceed the "Maximum Supply Air Temperature" specified in these instructions and on the furnace rating plate. Under NO circumstances can the furnace be allowed to operate above the Maximum Supply Air Temperature. Operating the furnace above the Maximum Supply Air Temperature will cause premature heat exchanger failure, high levels of Carbon Monoxide, a fire hazard, personal injury, property damage, and/or death.

The temperature rise, or temperature difference between the return air and the heated supply air from the furnace, must be within the range shown on the furnace rating plate and within the application limitations as shown in Table 7.

After about 20 minutes of operation, determine the furnace temperature rise. Take readings of both the return air and the heated air in the ducts, about six (6) feet (1.83 m) from the furnace where they will not be affected by radiant heat. Increase the blower speed to decrease the temperature rise; decrease the blower speed to increase the rise.

DIRECT DRIVE MOTORS

All direct-drive blowers have multi-speed motors. The blower motor speed taps are located in the control box in the blower compartment. Refer to Figure 29, and the unit-wiring label to change the blower speed. To use the same speed tap for heating and cooling, the heat terminal and cool terminal must be connected using a jumper wire and connected to the desired motor lead. Place all unused motor leads on Park terminals. Two are provided.

▲ CAUTION

Do not energize more than one motor speed at a time or damage to the motor will result.

ADJUSTMENT OF FAN CONTROL SETTINGS

This furnace is equipped with a time-on/time-off heating fan control. The fan on delay is fixed at 30 seconds. The fan off delay has 4 settings (60, 90, 120 and 180 seconds). The fan off delay is factory set to 120 seconds. The fan-off setting must be long enough to adequately cool the furnace, but not so long that cold air is blown into the heated space. The fan-off timing may be adjusted by positioning the jumper on two of the four pins as shown in Figure 29.

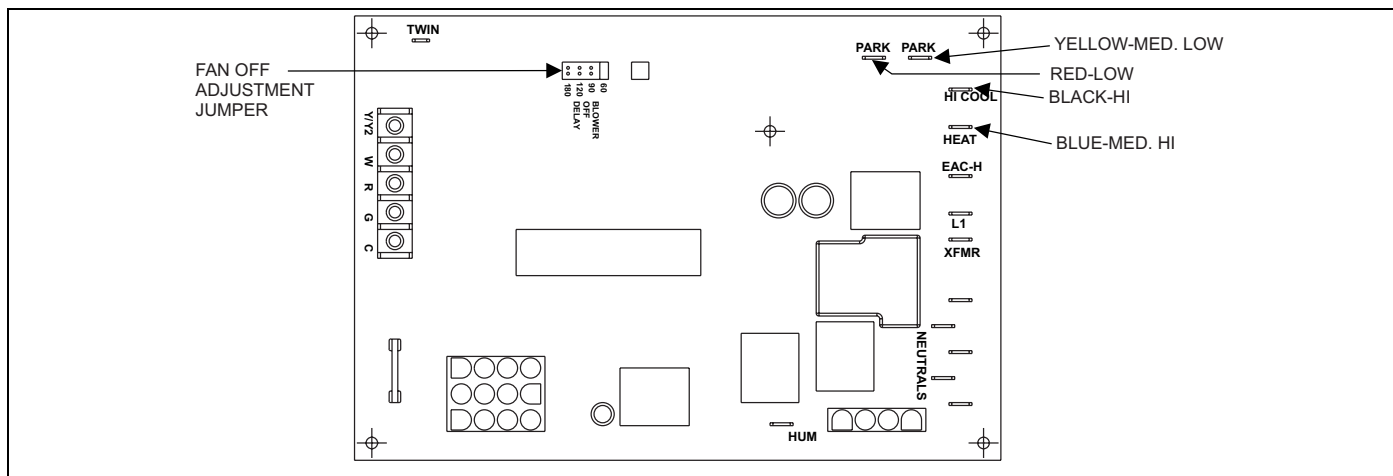

FIGURE 29: Furnace Control Board

FURNACE CONTROL DIAGNOSTICS

The furnace has built-in, self-diagnostic capability. If a system problem occurs, a blinking LED shows a fault code. The LED can flash red, green or amber to indicate various conditions. It is located behind a clear view port in the blower compartment door.

The control continuously monitors its own operation and the operation of the system. If a failure occurs, the LED will indicate the failure code. If the failure is internal to the control, the light will stay on continuously. In this case, the entire control should be replaced, as the control is not field repairable.

Flash sequence codes 1 through 10 are as follows: LED will turn "on" for 1/4 second and "off" for 1/4 second. This pattern will be repeated the number of times equal to the code. For example, six "on" flashes equals a number 6 fault code. All flash code sequences are broken by a 2 second "off" period.

SLOW GREEN FLASH: Normal operation.

SLOW AMBER FLASH: Normal operation with call for heat.

RAPID RED FLASH: Twinning error, incorrect 24V phasing. Check twinning wiring.

RAPID AMBER FLASH: Flame sense current is below 1.5 microamps. Check and clean flame sensor. Check for proper gas flow.

4 AMBER FLASHES: The control board is receiving a "Y" signal from the thermostat without a "G" signal, indicating improper thermostat wiring.

1 RED FLASH: This indicates that flame was sensed when there was not a call for heat. With this fault code the control will turn on both the inducer motor and supply air blower. A gas valve that leaks through or is slow closing would typically cause this fault.

2 RED FLASHES: This indicates that the normally open pressure switch contacts are stuck in the closed position. The control confirms these contacts are open at the beginning of each heat cycle. This would indicate a faulty pressure switch or miswiring.

3 RED FLASHES: This indicates the normally open pressure switch contact did not close after the inducer was energized. This could be caused by a number of problems: faulty inducer, blocked vent pipe, broken pressure switch hose or faulty pressure switch.

4 RED FLASHES: This indicates that a primary or auxiliary limit switch has opened its normally closed contacts. With this fault code the control will operate the supply air blower and inducer. This condition may be caused by: dirty filter, improperly sized duct system, incorrect blower speed setting, incorrect firing rate or faulty blower motor.

5 RED FLASHES: This fault is indicated if the normally closed contacts in the rollout switch opens. The rollout control is manually reset. If it has opened, check for proper combustion air, proper inducer operation, and primary heat exchanger failure or burner problem. Be sure to reset the switch after correcting the failure condition.

6 RED FLASHES: This indicates that after the unit was operating, the pressure switch opened 4 times during the call for heat. If the main blower is in a "Delay on" mode it will complete it, and any subsequent delay off period. The furnace will lock out for one hour and then restart.

7 RED FLASHES: This fault code indicates that the flame could not be established. This no-light condition occurred 3 times (2 retries) during the call for heat before locking out. Low gas pressure, faulty gas valve, faulty hot surface ignitor or burner problem may cause this. The furnace will lock out for one hour and then restart.

8 RED FLASHES: This fault is indicated if the flame is lost 5 times (4 recycles) during the heating cycle. This could be caused by low gas pressure or faulty gas valve. The furnace will lock out for one hour and then restart.

9 RED FLASHES: Indicates reversed line voltage polarity or grounding problem. Both heating and cooling operations will be affected. Check polarity at furnace and branch. Check furnace grounding. Check that flame probe is not shorted to chassis.

10 RED FLASHES: Gas valve energized with no call for heat. Check gas valve and gas valve wiring.

11 RED FLASHES: This indicates that a primary or auxiliary limit switch has opened its normally-closed contacts and has remained open for more than five minutes. This condition is usually caused by a failed blower motor or blower wheel.

12 RED FLASHES: This code indicates an open igniter circuit, which could be caused by a disconnected or loose wire or by a cracked or broken igniter.

STEADY ON RED: Control failure. Replace control board.

60-MINUTE AUTOMATIC RESET FROM LOCKOUT: This control includes a "watchdog" type circuit that will reset from a lockout condition after 60 minutes. Operational faults 6,7,8 will be reset. This provides protection to an unoccupied structure if a temporary condition exists causing a furnace malfunction. An example would be a low incoming gas supply pressure preventing unit operation. When the gas pressure is restored, at some point the "watchdog" would restart the unit and provide heat for the house.

NOTE: If a flame is detected the control flashes the LED for 1/8 of a second and then enters a flame stabilization period.

| |
|--|
| <p>IGNITION CONTROL</p> <p>Normal flame sense current is approximately 3.7 microamps DC (μa)</p> <p>Low flame signal warning starts at 1.5 microamps.</p> <p>Low flame signal control lockout point is 0.1 microamps DC (μa)</p> |
|--|

DIAGNOSTIC FAULT CODE STORAGE AND RETRIEVAL

The control in this furnace is equipped with memory that will store up to five error codes to allow a service technician to diagnose problems more easily. This memory will be retained even if power to the furnace is lost. **This feature should only be used by a qualified service technician.**

The control stores up to five separate error codes. If more than five error codes have occurred since the last reset, only the five most recent will be retained. The furnace control board has a button, labeled "LAST ERROR" that is used to retrieve error codes. This function will only work if there are no active thermostat signals. So any call for heating, cooling or continuous fan must be terminated before attempting to retrieve error codes.

To retrieve the error codes, push the LAST ERROR button. The LED on the control will then flash the error codes that are in memory, starting with the most recent. There will be a two-second pause between each flash code. After the error codes have all been displayed, the LED will resume the normal slow green flash after a five second pause. To repeat the series of error codes, push the button again.

If there are no error codes in memory, the LED will flash two green flashes. To clear the memory, push the LAST ERROR button and hold it for more than five seconds. The LED will flash three green flashes when the memory has been cleared, then will resume the normal slow green flash after a five-second pause.

FILTER PERFORMANCE

The airflow capacity data published in Table 15 represents blower performance WITHOUT filters. To determine the approximate blower performance of the system, apply the filter drop value for the filter being used or select an appropriate value from Table 14.

NOTE: The filter pressure drop values in Table 14 are typical values for the type of filter listed and should only be used as a guideline. Actual pressure drop ratings for each filter type vary between filter manufacturers.

TABLE 14: Filter Performance - Pressure Drop Inches W.C. and (kPa)

| Airflow Range | | Minimum Opening Size | | Filter Type | | | | | |
|---------------|---------------------|----------------------|-----------------|-------------|---------|----------------|---------|---------|---------|
| | | | | Disposable | | Washable Fiber | | Pleated | |
| CFM | m ³ /min | in ² | cm ² | In W.C. | kPA | In W.C. | kPA | In W.C. | kPA |
| 0 - 750 | 0 - 21.4 | 230 | 1484 | 0.01 | 0.00249 | 0.01 | 0.00249 | 0.15 | 0.03736 |
| 751 - 1000 | 21.25 - 28.32 | 330 | 2129 | 0.05 | 0.01245 | 0.05 | 0.01245 | 0.20 | 0.04982 |
| 1001 - 1250 | 28.33 - 35.40 | 330 | 2129 | 0.10 | 0.02491 | 0.10 | 0.02491 | 0.20 | 0.04982 |
| 1251 - 1500 | 35.41 - 42.48 | 330 | 2129 | 0.10 | 0.02491 | 0.10 | 0.02491 | 0.25 | 0.06227 |
| 1501 - 1750 | 42.49 - 49.55 | 380 | 2452 | 0.15 | 0.03736 | 0.14 | 0.03487 | 0.30 | 0.07473 |
| 1751 - 2000 | 49.56 - 56.63 | 380 | 2542 | 0.19 | 0.04733 | 0.18 | 0.04484 | 0.30 | 0.07473 |
| 2001 & Above | 56.64 - Above | 463 | 2987 | 0.19 | 0.04733 | 0.18 | 0.04484 | 0.30 | 0.07473 |

TABLE 15: Blower Performance CFM - (without filter)

| MODELS Input / CFM/kW | Speed | Airflow Data (SCFM) | | | | | | | | | | Airflow Data (m ³ min) | | | | | | | | | |
|-----------------------------|-------------|---------------------------------------|------|------|------|------|------|------|------|------|------|--|-------|-------|-------|-------|-------|-------|-------|-------|-------|
| | | External Static Pressure, Inches W.C. | | | | | | | | | | External Static Pressure, Inches (kPa) | | | | | | | | | |
| | | 0.1 | 0.2 | 0.3 | 0.4 | 0.5 | 0.6 | 0.7 | 0.8 | 0.9 | 1.0 | 0.025 | 0.050 | 0.075 | 0.100 | 0.125 | 0.149 | 0.174 | 0.199 | 0.224 | 0.249 |
| 40/1200/A† 11.7/34.0/A | High | 1620 | 1590 | 1480 | 1400 | 1310 | 1240 | 1140 | 1040 | 910 | 760 | 45.9 | 45.0 | 41.9 | 39.6 | 37.1 | 35.1 | 32.3 | 29.4 | 25.8 | 21.5 |
| | Medium High | 1430 | 1390 | 1340 | 1280 | 1220 | 1140 | 1050 | 960 | 820 | 710 | 40.5 | 39.4 | 37.9 | 36.2 | 34.5 | 32.3 | 29.7 | 27.2 | 23.2 | 20.1 |
| | Medium Low | 1210 | 1210 | 1190 | 1200 | 1100 | 1020 | 940 | 850 | 730 | 620 | 34.3 | 34.3 | 33.7 | 34.0 | 31.1 | 28.9 | 26.6 | 24.1 | 20.7 | 17.6 |
| | Low | 980 | 980 | 970 | 950 | 920 | 870 | 810 | 720 | 620 | 520 | 27.8 | 27.8 | 27.5 | 26.9 | 26.1 | 24.6 | 22.9 | 20.4 | 17.6 | 14.7 |
| 60/1200/A† 17.6/34.0/A | High | 1500 | 1470 | 1390 | 1320 | 1240 | 1170 | 1070 | 960 | 830 | 700 | 42.5 | 41.6 | 39.4 | 37.4 | 35.1 | 33.1 | 30.3 | 27.2 | 23.5 | 19.8 |
| | Medium High | 1380 | 1340 | 1280 | 1210 | 1150 | 1060 | 970 | 870 | 760 | 610 | 39.1 | 37.9 | 36.2 | 34.3 | 32.6 | 30.0 | 27.5 | 24.6 | 21.5 | 17.3 |
| | Medium Low | 1220 | 1200 | 1160 | 1110 | 1050 | 990 | 910 | 820 | 700 | 600 | 34.5 | 34.0 | 32.8 | 31.4 | 29.7 | 28.0 | 25.8 | 23.2 | 19.8 | 17.0 |
| | Low | 960 | 950 | 940 | 920 | 890 | 840 | 770 | 710 | 630 | 530 | 27.2 | 26.9 | 26.6 | 26.1 | 25.2 | 23.8 | 21.8 | 20.1 | 17.8 | 15.0 |
| 80/1200/A† 23.4/34.0/A | High | 1550 | 1480 | 1410 | 1330 | 1250 | 1150 | 1050 | 940 | 810 | 700 | 43.9 | 41.9 | 39.9 | 37.7 | 35.4 | 32.6 | 29.7 | 26.6 | 22.9 | 19.8 |
| | Medium High | 1400 | 1360 | 1290 | 1220 | 1150 | 1060 | 970 | 860 | 730 | 590 | 39.6 | 38.5 | 36.5 | 34.5 | 32.6 | 30.0 | 27.5 | 24.4 | 20.7 | 16.7 |
| | Medium Low | 1230 | 1210 | 1170 | 1120 | 1060 | 990 | 910 | 810 | 680 | 560 | 34.8 | 34.3 | 33.1 | 31.7 | 30.0 | 28.0 | 25.8 | 22.9 | 19.3 | 15.9 |
| | Low | 980 | 970 | 960 | 930 | 890 | 830 | 760 | 680 | 550 | 450 | 27.8 | 27.5 | 27.2 | 26.3 | 25.2 | 23.5 | 21.5 | 19.3 | 15.6 | 12.7 |
| 80/1600/B† 23.4/45.3/B | High | 2070 | 2000 | 1930 | 1850 | 1770 | 1670 | 1580 | 1470 | 1360 | 1250 | 58.6 | 56.6 | 54.7 | 52.4 | 50.1 | 47.3 | 44.7 | 41.6 | 38.5 | 35.4 |
| | Medium | 1650 | 1630 | 1610 | 1560 | 1490 | 1420 | 1360 | 1270 | 1170 | 1040 | 46.7 | 46.2 | 45.6 | 44.2 | 42.2 | 40.2 | 38.5 | 36.0 | 33.1 | 29.4 |
| | Low | 1410 | 1400 | 1370 | 1340 | 1320 | 1270 | 1210 | 1140 | 1050 | 950 | 39.9 | 39.6 | 38.8 | 37.9 | 37.4 | 36.0 | 34.3 | 32.3 | 29.7 | 26.9 |
| 80/1600/C† 23.4/45.3/C | High | 1895 | 1812 | 1736 | 1624 | 1544 | 1437 | 1311 | 1153 | 1032 | 836 | 53.6 | 51.3 | 49.1 | 46.0 | 43.7 | 40.7 | 37.1 | 32.6 | 29.2 | 23.7 |
| | Medium | 1726 | 1645 | 1581 | 1491 | 1412 | 1311 | 1192 | 1049 | 908 | 750 | 48.8 | 46.6 | 44.7 | 42.2 | 40.0 | 37.1 | 33.7 | 29.7 | 25.7 | 21.2 |
| | Low | 1561 | 1493 | 1430 | 1373 | 1304 | 1199 | 1089 | 967 | 816 | 699 | 44.2 | 42.3 | 40.5 | 38.9 | 36.9 | 33.9 | 30.8 | 27.4 | 23.1 | 19.8 |
| 100/1200/B† 29.3/34.0/B | High | 1710 | 1650 | 1580 | 1510 | 1420 | 1330 | 1260 | 1160 | 1090 | 930 | 48.4 | 46.7 | 44.7 | 42.8 | 40.2 | 37.7 | 35.7 | 32.8 | 30.9 | 26.3 |
| | Medium High | 1480 | 1440 | 1380 | 1330 | 1270 | 1180 | 1090 | 980 | 790 | 630 | 41.9 | 40.8 | 39.1 | 37.7 | 36.0 | 33.4 | 30.9 | 27.8 | 22.4 | 17.8 |
| | Medium Low | 1240 | 1230 | 1200 | 1170 | 1110 | 1030 | 950 | 850 | 710 | 600 | 35.1 | 34.8 | 34.0 | 33.1 | 31.4 | 29.2 | 26.9 | 24.1 | 20.1 | 17.0 |
| 100/1600/C† 29.3/45.3/C | High | 2210 | 2160 | 2100 | 2030 | 1940 | 1850 | 1750 | 1640 | 1520 | 1400 | 62.6 | 61.2 | 59.5 | 57.5 | 54.9 | 52.4 | 49.6 | 46.4 | 43.0 | 39.6 |
| | Medium | 1640 | 1640 | 1620 | 1590 | 1530 | 1500 | 1430 | 1360 | 1270 | 1160 | 46.4 | 46.4 | 45.9 | 45.0 | 43.3 | 42.5 | 40.5 | 38.5 | 36.0 | 32.8 |
| | Low | 1410 | 1410 | 1370 | 1360 | 1300 | 1260 | 1210 | 1150 | 1090 | 1010 | 39.9 | 39.9 | 38.8 | 38.5 | 36.8 | 35.7 | 34.3 | 32.6 | 30.9 | 28.6 |
| 100/2000/C† 29.3/56.6/C | High | 2400 | 2330 | 2240 | 2130 | 2030 | 1960 | 1820 | 1710 | 1570 | 1390 | 68.0 | 66.0 | 63.4 | 60.3 | 57.5 | 55.5 | 51.5 | 48.4 | 44.5 | 39.4 |
| | Medium High | 2130 | 2070 | 2000 | 1940 | 1840 | 1760 | 1660 | 1540 | 1420 | 1230 | 60.3 | 58.6 | 56.6 | 54.9 | 52.1 | 49.8 | 47.0 | 43.6 | 40.2 | 34.8 |
| | Medium Low | 1800 | 1760 | 1730 | 1650 | 1580 | 1510 | 1430 | 1300 | 1200 | 1030 | 51.0 | 49.8 | 49.0 | 46.7 | 44.7 | 42.8 | 40.5 | 36.8 | 34.0 | 29.2 |
| | Low | 1480 | 1450 | 1390 | 1360 | 1300 | 1240 | 1180 | 1080 | 960 | 860 | 41.9 | 41.1 | 39.4 | 38.5 | 36.8 | 35.1 | 33.4 | 30.6 | 27.2 | 24.4 |
| 115/1600/C† 33.7/45.3/C | High | 2210 | 2160 | 2100 | 2030 | 1940 | 1850 | 1750 | 1640 | 1520 | 1400 | 62.6 | 61.2 | 59.5 | 57.5 | 54.9 | 52.4 | 49.6 | 46.4 | 43.0 | 39.6 |
| | Medium | 1640 | 1640 | 1620 | 1590 | 1530 | 1500 | 1430 | 1360 | 1270 | 1160 | 46.4 | 46.4 | 45.9 | 45.0 | 43.3 | 42.5 | 40.5 | 38.5 | 36.0 | 32.8 |
| | Low | 1410 | 1410 | 1370 | 1360 | 1300 | 1260 | 1210 | 1150 | 1090 | 1010 | 39.9 | 39.9 | 38.8 | 38.5 | 36.8 | 35.7 | 34.3 | 32.6 | 30.9 | 28.6 |
| 115/2000/C† 33.7/56.6/C | High | 2400 | 2310 | 2220 | 2120 | 2010 | 1910 | 1800 | 1660 | 1520 | 1350 | 68.0 | 65.4 | 62.9 | 60.0 | 56.9 | 54.1 | 51.0 | 47.0 | 43.0 | 38.2 |
| | Medium High | 2090 | 2030 | 1970 | 1880 | 1790 | 1730 | 1640 | 1520 | 1370 | 1190 | 59.2 | 57.5 | 55.8 | 53.2 | 50.7 | 49.0 | 46.4 | 43.0 | 38.8 | 33.7 |
| | Medium Low | 1720 | 1690 | 1650 | 1600 | 1550 | 1460 | 1370 | 1270 | 1150 | 980 | 48.7 | 47.9 | 46.7 | 45.3 | 43.9 | 41.3 | 38.8 | 36.0 | 32.6 | 27.8 |
| | Low | 1440 | 1430 | 1400 | 1340 | 1280 | 1220 | 1140 | 1040 | 930 | 830 | 40.8 | 40.5 | 39.6 | 37.9 | 36.2 | 34.5 | 32.3 | 29.4 | 26.3 | 23.5 |
| 130/2000/D† 38.1/56.6/D | High | 2530 | 2420 | 2340 | 2250 | 2110 | 2020 | 1920 | 1750 | 1590 | 1410 | 71.6 | 68.5 | 66.3 | 63.7 | 59.7 | 57.2 | 54.4 | 49.6 | 45.0 | 39.9 |
| | Medium High | 2190 | 2150 | 2070 | 1970 | 1910 | 1790 | 1680 | 1550 | 1400 | 1250 | 62.0 | 60.9 | 58.6 | 55.8 | 54.1 | 50.7 | 47.6 | 43.9 | 39.6 | 35.4 |
| | Medium Low | 1800 | 1760 | 1720 | 1680 | 1610 | 1490 | 1410 | 1300 | 1160 | 1040 | 51.0 | 49.8 | 48.7 | 47.6 | 45.6 | 42.2 | 39.9 | 36.8 | 32.8 | 29.4 |
| | Low | 1450 | 1440 | 1410 | 1360 | 1310 | 1250 | 1170 | 1080 | 980 | 860 | 41.1 | 40.8 | 39.9 | 38.5 | 37.1 | 35.4 | 33.1 | 30.6 | 27.8 | 24.4 |

NOTES:

1. Airflow expressed in standard cubic feet per minute (CFM) and in cubic meters per minute (m³/min).
2. Motor voltage at 115 V.

† Indicates model available in LoNOx.

APPLYING FILTER PRESSURE DROP TO DETERMINE SYSTEM AIRFLOW

To determine the approximate airflow of the unit with a filter in place, follow the steps below:

1. Select the filter type.
2. Select the number of return air openings or calculate the return opening size in square inches to determine the proper filter pressure drop.
3. Determine the External System Static Pressure (ESP) without the filter.
4. Select a filter pressure drop from the table based upon the number of return air openings or return air opening size and add to the ESP from Step 3 to determine the total system static.
5. If total system static matches an ESP value in the airflow table (i.e. 0.20 w.c. (50 Pa), 0.60 w.c. (150 Pa), etc.) the system airflow corresponds to the intersection of the ESP column and Model/Blower Speed row.
6. If the total system static falls between ESP values in the table (i.e. 0.58 w.c. (144 Pa), 0.75 w.c. (187 Pa), etc.), the static pressure may be rounded to the nearest value in the table determining the airflow using Step 5 or calculate the airflow by using the following example.

Example: For a 60,000 BTUH (38.06 kW) furnace operating on high-speed blower, it is found that total system static is 0.58" w.c. To determine the system airflow, complete the following steps:

Obtain the airflow values at 0.50 w.c. (125 Pa) & 0.60 w.c. (150 Pa) ESP.

Airflow @ 0.50": 1240 CFM (35.1 m³/min)

Airflow @ 0.60": 1170 CFM (23.1 m³/min)

Subtract the airflow @ 0.50 w.c. (125 Pa) from the airflow @ 0.60 w.c. (150 Pa) to obtain airflow difference.

1170 - 1240 = -70 CFM (2.0 m³/min)

Subtract the total system static from 0.50 w.c. (125 Pa) and divide this difference by the difference in ESP values in the table

0.60 w.c. (150 Pa) - 0.50 w.c. (125 Pa), to obtain a percentage.

$(0.58 - 0.50) / (0.60 - 0.50) = 0.8$

Multiply percentage by airflow difference to obtain airflow reduction.

$(0.8) \times (-70) = -56$ CFM (0.8) x (2.0) = 1.6 m³/min

Subtract airflow reduction value to airflow @ 0.50 w.c. (125 Pa) to obtain actual airflow @ 0.58 in. w.c. (144 Pa) ESP.

1240 (35.1) - 56 (1.6) = 1184 (33.5)

TABLE 16: Field Installed Accessories - Non Electrical

| MODEL NO. | DESCRIPTION | USED WITH |
|-----------|---|------------------------|
| 1NP0347 | PROPANE (LP) CONVERSION KIT | ALL MODELS |
| 1PS0301 | HIGH ALTITUDE PRESSURE SWITCH KIT* (Does Not Include Orifices) | 40, 60, 80 MBH |
| 1PS0311 | | 100, 115, 130 MBH |
| 1CB0314 | COMBUSTIBLE FLOOR BASE FOR DOWNFLOW UNITS | 14-1/2" ("A") CABINETS |
| 1CB0317 | | 17-1/2" ("B") CABINETS |
| 1CB0321 | | 21" ("C") CABINETS |
| 1CB0324 | | 24-1/2" ("D") CABINETS |

SECTION X: WIRING DIAGRAM

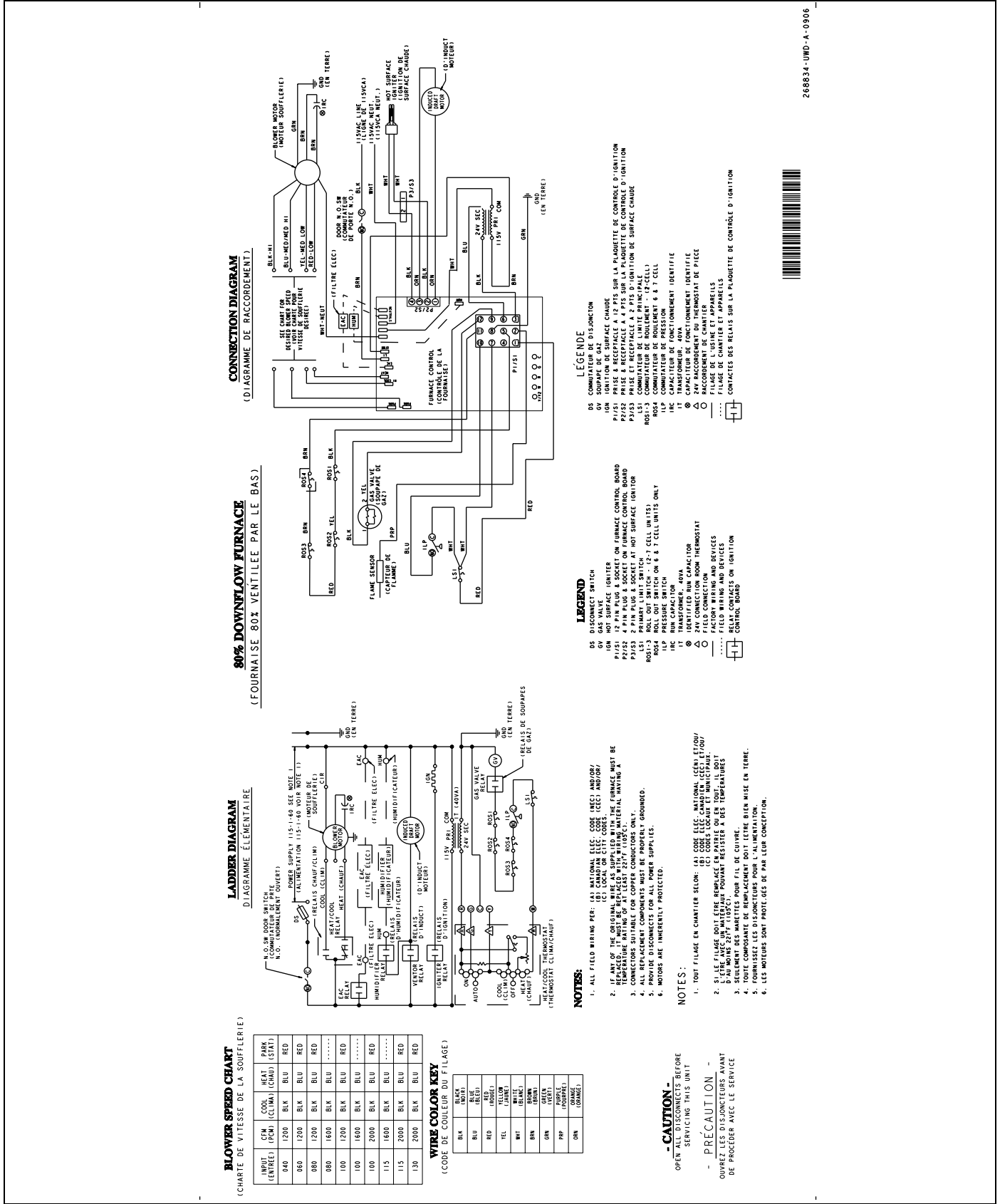

FIGURE 30: Wiring Diagram

NOTES