

Gigaset

C300 H
C300 H

Issued by
Gigaset Communications GmbH
Frankenstr. 2a, D-46395 Bocholt
Manufactured by Gigaset Communications GmbH
under trademark license of Siemens AG.
As of 1 Oct. 2011 Gigaset products bearing the
trademark 'Siemens' will exclusively use the trademark 'Gigaset'.

© Gigaset Communications GmbH 2010
All rights reserved. Subject to availability.
Rights of modification reserved.
www.gigaset.com

GIGASET. INSPIRING CONVERSATION.*
*GIGASET. Pour des conversations inspirées.
MADE IN GERMANY

SIEMENS

Gigaset C300H – your high-quality accessory

Congratulations on your purchase of this latest generation Gigaset.

Your Gigaset can do a lot more than just make calls:

Directory for up to 250 entries

Save phone numbers and names to the directory (→ page 25). You can designate important entries as VIPs (Very Important Persons). VIP calls are then recognised by their ringer and their colour in the directory (→ page 26).

If you don't (always) want it to ring

Use time control for calls (→ page 32) or ensure that all calls from a withheld number are not signalled (→ page 33).

Other practical information

Transfer the directory from an existing Gigaset handset (→ page 26), use the shortcut function (→ page 26) and adjust the colour and contrast of the display to your requirements (→ page 31).

Protecting our environment

Gigaset Green Home — Be environmentally aware when using your phone. Details about our ECO DECT products can be found at www.gigaset.com/service.

Further information on your phone can be found at www.gigaset.com/gigasetc300h.

After purchasing your Gigaset phone, please register it at www.gigaset.com/service this will ensure any questions you may have or warranty services you request are dealt with even faster!

Have fun using your new phone!

Overview

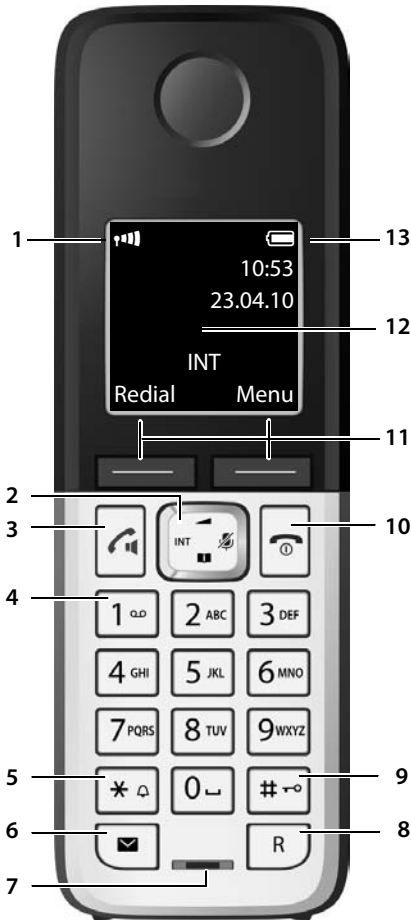

- 1 **Signal strength** (→ page 15)
Colour/Symbol changes when Eco Mode / Eco Mode+ is activated (→ page 30)
- 2 **Control key** (→ page 17)
Mute microphone (→ page 24)
- 3 **Talk/Handsfree key**
Flashes: incoming call;
Lights up: handsfree mode activated;
accept call; open redial list (press briefly);
start dialling (press and hold);
during a call: switch between earpiece and
handsfree mode (→ page 24)
- 4 **Key 1**
Dial network mailbox (press and hold)
- 5 **Star key**
Activate/deactivate ringer (press and hold);
With an open connection: switch between
pulse dialling/tone dialling (press briefly)
- 6 **Message key** (→ page 27)
Access to call and message lists;
Flashes: new message or new call
- 7 **Microphone**
- 8 **Recall key**
- Recall
- Insert a dialling pause (press and hold)
- 9 **Hash key**
Keypad lock on/off (press and hold in idle sta-
tus);
Toggles between upper/lower case and digits
- 10 **End call key, On/Off key**
End call; cancel function; go back one menu
level (press briefly); back to idle status (press
and hold); activate/deactivate handset (press
and hold in idle status)
- 11 **Display keys** (→ page 4)
- 12 **Display in idle status**
- 13 **Battery charge status** (→ page 15)

Please note
To change **the display language, proceed as described on page 31.**

Understanding the display icons

The following symbols are displayed dependent on the settings and the operating status of your telephone:

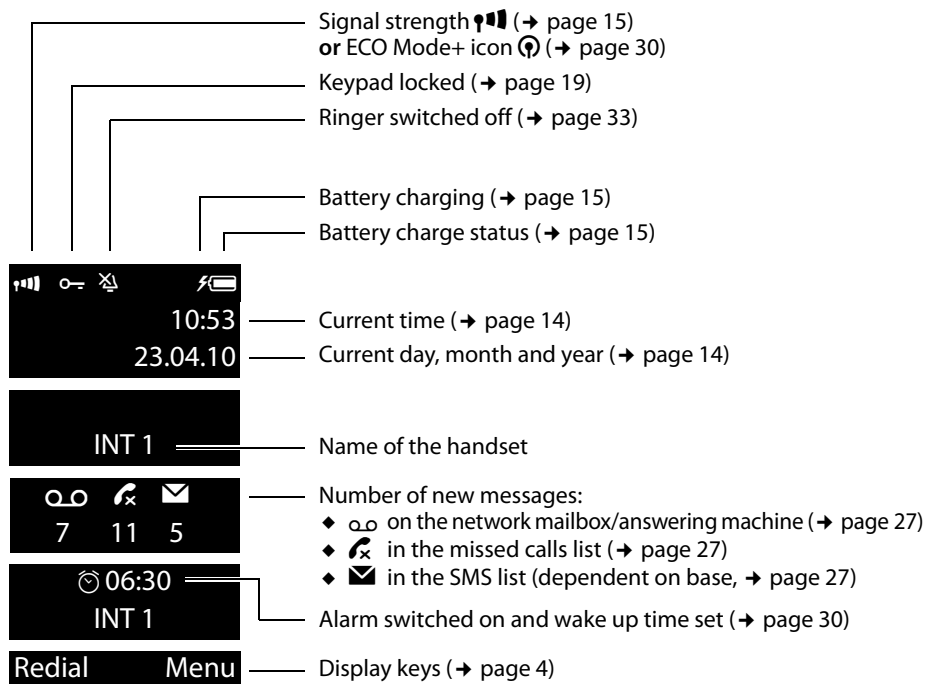

Display during external call:

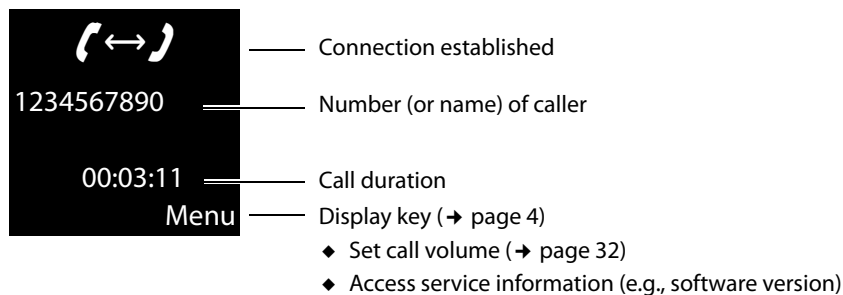

Using the display keys

Other display icons:

Establishing a connection



Connection established



Connection cannot be established or connection interrupted



External call (→ page 23)



Internal call (→ page 24)



Alarm call (→ page 30)



Please wait ...



Information

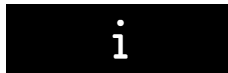

Query



Action complete



Action failed



Using the display keys

The functions of the display keys change depending on the particular operating situation. Example:



- ① Current display key function
- ② Display keys

Important display keys:

Redial	Open redial list.
Menu	Open a menu for further functions.
OK	Confirm selection.
Del.	Delete key: Delete character by character/word by word from right to left.
Back	Go back one menu level or cancel operation.

Main menu icons

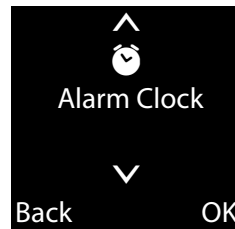

- SMS (dependent on base)
- Alarm Clock
- Voice Mail
- Settings

Information on using the menus → page 18
Menu overview → page 22

Contents

Gigaset C300H – your high-quality accessory	1
Overview	2
Understanding the display icons	3
Using the display keys	4
Main menu icons	4
Following safety precautions	7
Taking the first steps	8
Checking the package contents	8
Setting up the charger	9
Connecting the charger	9
Setting up the handset for use	10
Changing the display language	11
Registering the handset	12
Setting the date and time	14
What would you like to do next?	16
Using the phone	17
Using the control key	17
Using keys on the keypad	17
Correcting incorrect entries	17
Using the menus	18
Activating/deactivating the handset	19
Activating/deactivating keypad lock	19
Understanding the operating steps	20
Menu overview	22
Making calls	23
Making an external call	23
Ending a call	23
Accepting a call	23
Using handsfree mode	24
Switching to mute	24
Making internal calls	24
Using the directory and lists	25
Directory	25
Using the redial list	27
Message key function	27
Incoming message list (dependent on base)	28
Call list (dependent on base)	28

- Using the network mailbox** 29
 - Using fast access for the network mailbox 29
 - Viewing the network mailbox message 29
- ECO DECT** 30
- Using the handset as an alarm clock** 30
- Handset settings** 31
 - Changing the display language 31
 - Setting the display/screensaver 31
 - Activating/deactivating auto answer 31
 - Changing the handsfree/earpiece volume 32
 - Changing ringtones 32
 - Changing the base 33
 - Restoring the handset default settings 33
- Service (Customer Care)** 34
 - Questions and answers 35
 - Authorisation 35
 - Guarantee Certificate
 - United Kingdom 36
 - Guarantee Certificate
 - Ireland 36
- Protecting our environment** 38
- Appendix** 39
 - Caring for your telephone 39
 - Contact with liquid 39
 - Specifications 39
 - Writing and editing text 40
- Accessories** 42
- Mounting the charger on the wall** 42
- Index** 43

Following safety precautions

Warning

Be sure to read this user guide and the safety precautions before using your telephone.

Explain their content and the potential hazards associated with using the telephone to your children.



Use only the power adapter supplied.



Use only **rechargeable batteries** that correspond to the **specification provided on page 39**, as this could otherwise result in significant health risks and personal injury.



Using your telephone may affect nearby medical equipment. Be aware of the technical conditions in your particular environment, e.g., doctor's surgery. If you use a medical device (e.g., a pacemaker), please contact the device manufacturer. They will be able to advise you regarding the susceptibility of the device to external sources of high frequency energy. Please refer to the "Appendix" chapter for the specifications of this Gigaset product.



Do not hold the rear of the handset to your ear when it is ringing or when speaker mode is activated. Otherwise you risk serious and permanent damage to your hearing.

Your Gigaset is compatible with the majority of digital hearing aids on the market. However, perfect function with all hearing aids cannot be guaranteed.

The handset may cause interference in analogue hearing aids. If you require assistance, please contact the hearing aid supplier.



Do not install the charger in bathrooms or shower rooms. The charger is not splash-proof (→ page 39).



Do not use your phone in environments with a potential explosion hazard (e.g., paint shops).



If you give your Gigaset to a third party, make sure you also give them the user guide.



Remove faulty bases from use or have them repaired by our Service, as these could interfere with other wireless services.

Please note

- ◆ Not all of the functions described in this user guide are available in all countries.
- ◆ The device cannot be used in the event of a power failure. It is also **not** possible to transmit **emergency calls**.

Taking the first steps

Checking the package contents



- 1 One Gigaset C300H handset
- 2 Two batteries
- 3 One battery cover
- 4 One charger
- 5 One power adapter
- 6 One user guide

Setting up the charger

The charger is designed for use in dry rooms in a temperature range of +5°C to +45°C.

- ▶ Set up the charger on a level, non-slip surface or mount the charger on the wall
→ page 42.

Please note

Pay attention to the range of the base.

This is up to 300 m in unobstructed outdoor areas and up to 50 m inside buildings. The range is reduced when Eco Mode is activated (→ page 30).

The phone's feet do not usually leave any marks on surfaces. However, due to the multitude of different varnishes and polishes used on today's furnishings, the occurrence of marks on the surfaces cannot be completely ruled out.

Please note:

- ◆ Never expose the telephone to the influence of heat sources, direct sunlight or other electrical devices.
- ◆ Protect your Gigaset from moisture, dust, corrosive liquids and fumes.

Connecting the charger

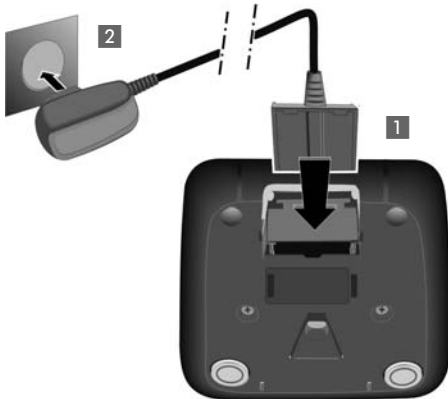

- ▶ Connect the flat plug from the power adapter **1**.
- ▶ Plug the power adapter into the plug socket **2**.

To disconnect the plug from the charger, press the release button **3** and disconnect the plug **4**.

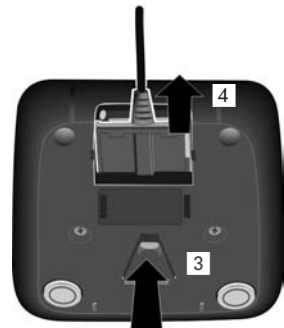

Setting up the handset for use

The display is protected by a plastic film.
Please remove the protective film!

Inserting the batteries and closing the battery cover

Warning

Use only rechargeable batteries (→ page 39) recommended by Gigaset Communications GmbH, as this could otherwise result in significant health risks and personal injury. For example, the outer casing of the batteries could be destroyed or the batteries could explode. The phone could also malfunction or be damaged as a result of using batteries that are not of the recommended type.

- ▶ Insert the batteries with the polarity in the correct direction. The polarity is indicated in the battery compartment.



- ▶ First insert the battery cover at the top (a).
- ▶ Then press the cover (b) until it clicks into place.

To open the battery cover, for instance to replace the batteries, insert a coin into the cavity on the casing, then pull the battery cover in an upward direction.



Changing the display language

Change the display language, if you do not understand the language currently set.



- ▶ Press right on the control key.
- ▶ Press the keys **6_{MNO}** and **4_{GHI}** **slowly** one after the other.

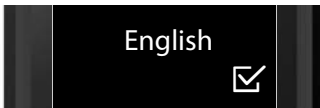

The display for setting languages appears. The current language (e.g., English) is selected

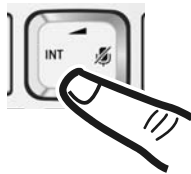

- ▶ Press down on the control key  ...

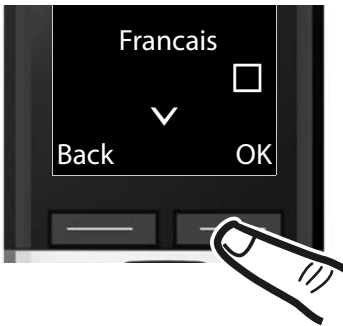

... until the language you wish to use is displayed e.g., French.

- ▶ Press the key below **OK** to select this language.



The selection is marked with .

- ▶ Press and **hold** the end call key  to return to idle status.

Registering the handset

Before you can use the phone, you must first register the handset to the base. The registration procedure will depend on the type of base.

Automatically registering the C300H handset to the Gigaset C300/C300A base

Prerequisite: The handset must not already be registered to a base.



- ▶ Place the handset with the **display facing up** in the base.

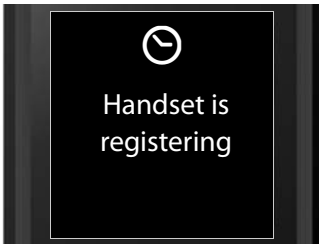

The handset registers automatically. Registration can take **up to 5 minutes**. **Do not remove the handset from the base during this time.**

Please note

- ◆ Each key press interrupts automatic registration.
- ◆ If the handset is already registered to at least one base or if automatic registration does not work, the handset will have to be registered manually.

Manually registering the C300H handset

You must manually register the handset on both the handset (1) and the base (2).

1) On the handset

Menu ▶ **Settings** ▶ **Registration** ▶ **Register Handset**

If the handset is already registered to four bases:



Select base e.g., **Base 3** and press **OK**.



If required, enter the system PIN for the base and press **OK**.

The display shows **Handset is registering**.

2) On the base

- ▶ Within 60 seconds, press and **hold** the registration/paging key on the base (approx. 3 seconds).

A Gigaset C300H handset can be registered on up to four bases.

Once the registration process has been completed successfully, the handset returns to idle status. The handset's internal number is shown in the display e.g., INT 2. If not, repeat the procedure.

Please note

For instructions on deregistering the handsets, please consult the base user guide.

Initial charging and discharging of the batteries

The correct charge status can only be displayed if the battery is first fully charged **and** then discharged.

- ▶ Charge the handset in the charger for **7.5 hours**.

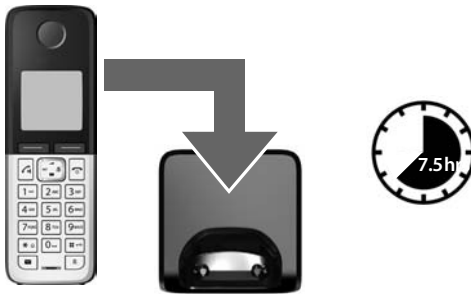

Please note

The handset must only be placed in the designated Gigaset C300/C300A base or charger.

- ▶ After charging, remove the handset from the charger and only replace it when the batteries are **fully discharged**.

Please note

- ◆ After the first battery charge **and** discharge, you may place your handset in the charger after every call.
- ◆ Always repeat the charging and discharging procedure if you remove the batteries from the handset and reinsert them.
- ◆ The batteries may warm up during charging. This is not dangerous.
- ◆ After a while, the charge capacity of the batteries will decrease for technical reasons.

Setting the date and time

Set the date and time so that the correct date and time can be assigned to incoming calls, and so that the alarm can be used.

Please note

Depending on your network provider, the date and time may be displayed automatically.

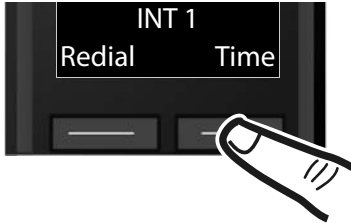

- ▶ Press the key below **Time** on the display screen to open the input field. (If you have already set the time and date, open the input field via the menu → page 22.)

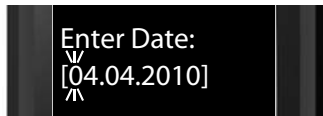

The **Date/Time** submenu is shown on the display.

- ▶ The active input position flashes. Enter the day, month and year as an 8-digit number via the keypad e.g.,

0	4	0	4	2	0	1	0
---	---	---	---	---	---	---	---

 for 4 April 2010.

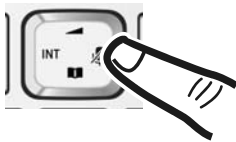

To change the input position e.g., to correct an entry, press **right** or **left** on the control key.



- ▶ Press the key below **OK** on the display screen to save your entry.



- ▶ Enter the hours and minutes in 4-digit format via the keypad e.g.,

0	7	1	5
---	---	---	---

 for 07:15 am. Change the input position with the control key if necessary.
- ▶ Confirm with **OK**.



The display shows **Saved**. You will hear a confirmation tone and the handset automatically reverts to idle status, or returns to the "Settings" menu if the setting was made via the menu.

Display in idle status

Once the phone is registered and the time set, the screen display is as follows (example).

Screen display

- ◆ Reception between the base and the handset:
 - Good to poor:
 - No reception:
- Green:** Eco Mode activated (→ page 30)
- ◆ Charge status of the batteries:
 - white: charged over 66 %
 - white: charged between 33 % and 66 %
 - red: charged between 10% and 33%
 - red: charged below 10%
 - white: batteries charging

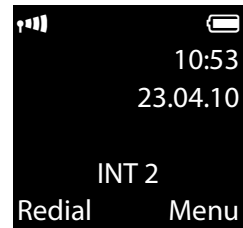

Please note

If you have chosen the colour scheme with the white background, the white symbols will be shown in black.

- ◆ INT 2
Internal name of the handset

If **Eco Mode+** (→ page 30) is activated, the icon is displayed in the top left corner of the display.

Your phone is now ready for use!

What would you like to do next?

Now that you have successfully set up your Gigaset, you can immediately start calling – or you can adapt it to your personal requirements. Use the following guide to quickly locate the most important functions.

Information on is located here.
Using the phone	page 17
Setting ringtones	page 32
Transferring directory entries from existing Gigaset handsets to new handset(s)	page 26
Setting Eco Mode / Eco Mode+	page 30
Setting the earpiece volume	page 32

If you have any questions about using your phone, please read the tips on troubleshooting (→ page 35) or contact our Service team (→ page 34).

Using the phone





Using the control key

In the description below, the side of the control key (up, down, right, left) which you have to press in the different operating situations is marked in black e.g.,  for "press the right edge of the control key".



The control key has a number of different functions:





When the handset is in idle status

-  Open the main menu.
-  Open the directory.
-  Open the list of handsets.
-  Call up the menu for setting the handset's call volume (→ page 32).





In menus and lists

-  /  Scroll up/down line by line.

In input fields

You can use the control key to move the cursor up , down , right  or left .

During an external call

-  Mute the microphone.
-  Open the directory.
-  Initiate an internal consultation call.
-  Adjust the loudspeaker volume for earpiece and handsfree mode.

Using keys on the keypad

-  /  /  etc.
Press the matching key on the handset.

-  Enter digits or letters.

Correcting incorrect entries

You can correct incorrect characters in the input fields by navigating to the incorrect entry using the control key. You can then:

- ◆ Use the display key **Del.** to delete the character to the left of the cursor
- ◆ Insert characters at the cursor position
- ◆ Overwrite the highlighted (flashing) character e.g., when entering time and date.

Using the menus

Your telephone's functions are accessed via a menu consisting of several levels (menu overview → page 22).



Main menu (first menu level)

- ▶ With the handset in idle status, press the display key **Menu** or right on the control key  to open the main menu.

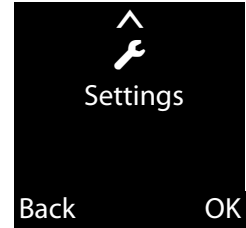
The functions in the main menu are displayed in the form of a list with names and icons (example on the right).



Selecting a function

- ▶ You can scroll between functions using the control key . The selectable function is shown in the display.
- ▶ Press the display key **OK** or right on the control key  to select the displayed function. This opens the corresponding submenu and the first entry is displayed.

If you press the display key **Back** or **briefly** press the end call key , the display returns to idle status.

Submenus

The functions in the submenu are displayed with the corresponding names.

Selecting a function

- ▶ You can scroll between functions using the control key . The relevant function is shown in the display.
- ▶ Press the display key **OK** to select the displayed function. This opens the corresponding submenu and the first entry is displayed.

Briefly press the display key **Back** or the end call key  to return to the previous menu level or cancel the operation.

Any settings you have not confirmed by pressing **OK** will be discarded.

Reverting to idle status

From any point in the menu:

- ▶ Press and **hold** the end call key  or
- ▶ Do not press any key: after 2 minutes, the display will **automatically** revert to idle status.

An example of the display in idle status is shown on page 15.

Activating/deactivating the handset



In idle status, press and **hold** the end call key (confirmation tone).

Activating/deactivating keypad lock

Keypad lock prevents any inadvertent use of the phone.



In idle status, press and **hold** the hash key (confirmation tone). The keypad lock is switched on or off. When it is switched on, the  icon appears in the display.

If the keypad lock is activated, a corresponding message is displayed when you press a key.

Keypad lock deactivates automatically when you receive a call. It is reactivated when the call is finished.

Please note

When keypad lock is active, you cannot even call emergency numbers.

Understanding the operating steps

The operating steps are shown in abbreviated form, for example:

Menu ▶ **Settings** ▶ **Eco Mode** (☑ = on)

▶ This means you should proceed as follows:

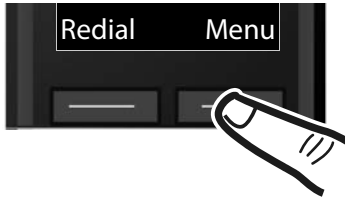

▶ Press the key below **Menu** on the display screen to open the main menu.

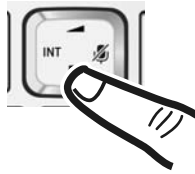

▶ Press down on the control key  ...



... until the menu item **Settings** appears on the screen.

▶ Press the key below **OK** on the display screen to confirm your selection.



▶ Press down on the control key  ...



... until the **Eco Mode** menu item appears.

- ▶ Press the key below **OK** on the display screen to switch the function on or off (☑ = on).

- ▶ Press the key below **Back** on the display screen to jump back to the previous menu level.

Or

Press and **hold** the end call key  to return to idle status.

Menu overview

The menu entries are partially subdivided. The page numbers refer to the relevant description in the user guide.

To open the main menu: press the display key **Menu** when the phone is in idle mode.

 **SMS** (Menu dependent on base)

 **Alarm Clock**

Activation	→ page 30
Wake up time	→ page 30

 **Voice Mail** (Menu dependent on base)

 **Settings**

Date/Time	→ page 14										
Audio Settings	<table border="1"> <tr> <td>Call Volume</td> <td>→ page 32</td> </tr> <tr> <td>Ringer Volume</td> <td>→ page 32</td> </tr> <tr> <td>Advisory Tones</td> <td>→ page 32</td> </tr> <tr> <td>Battery Low</td> <td>→ page 32</td> </tr> <tr> <td>Ringtones (Handset)</td> <td>→ page 32</td> </tr> </table>	Call Volume	→ page 32	Ringer Volume	→ page 32	Advisory Tones	→ page 32	Battery Low	→ page 32	Ringtones (Handset)	→ page 32
Call Volume	→ page 32										
Ringer Volume	→ page 32										
Advisory Tones	→ page 32										
Battery Low	→ page 32										
Ringtones (Handset)	→ page 32										
Display	<table border="1"> <tr> <td>Screensaver</td> <td>→ page 31</td> </tr> <tr> <td>Colour Schemes</td> <td>→ page 31</td> </tr> <tr> <td>Contrast</td> <td>→ page 31</td> </tr> <tr> <td>Backlight</td> <td>→ page 31</td> </tr> </table>	Screensaver	→ page 31	Colour Schemes	→ page 31	Contrast	→ page 31	Backlight	→ page 31		
Screensaver	→ page 31										
Colour Schemes	→ page 31										
Contrast	→ page 31										
Backlight	→ page 31										
Language	→ page 31										
Registration	<table border="1"> <tr> <td>Register Handset</td> <td>→ page 12</td> </tr> <tr> <td>Select Base</td> <td>→ page 33</td> </tr> <tr> <td>De-register Handset</td> <td>(dependent on base)</td> </tr> </table>	Register Handset	→ page 12	Select Base	→ page 33	De-register Handset	(dependent on base)				
Register Handset	→ page 12										
Select Base	→ page 33										
De-register Handset	(dependent on base)										
Telephony	<table border="1"> <tr> <td>Auto Answer</td> <td>→ page 31</td> </tr> </table> <p>(further submenus dependent on base)</p>	Auto Answer	→ page 31								
Auto Answer	→ page 31										
System	<table border="1"> <tr> <td>Reset Handset</td> <td>→ page 33</td> </tr> </table> <p>(further submenus dependent on base)</p>	Reset Handset	→ page 33								
Reset Handset	→ page 33										
Eco Mode	→ page 30										
Eco Mode+	→ page 30										

Making calls

When the display backlight is switched off (→ page 31), pressing any key will activate the backlight. The relevant key function is performed.

Making an external call

External calls are calls using the public telephone network.



Enter the number and press the talk key.

Or:



Press and **hold** the talk key and then enter the number.

You can cancel the dialling operation with the end call key.

You are shown the duration of the call while the call is in progress.

Please note

Dialling with the directory (→ page 25), call list (→ page 28) and redial list (→ page 27) saves you from repeatedly keying in phone numbers.

Ending a call



Press the end call key.

Accepting a call

The handset indicates an incoming call in three ways: by ringing, by a display on the screen and by the flashing talk key.

To accept the call, press the talk key.

If the handset is in the charger and the **Auto Answer** function is activated (→ page 31), the handset automatically answers calls when you remove it from the base/charger.

If the ringer is intrusive, you can deactivate it:

Menu ▶ **Silent** ▶ **OK**

You can accept the call as long as it is displayed on the screen.

Using handsfree mode

In handsfree mode, you activate the loud-speaker so that you can hear the caller without having to hold the handset to your ear. You therefore have both hands free and other people can listen in on the conversation.

Please note

Inform your caller before you use the handsfree function so that the caller knows a third party may be listening.

Activating/deactivating handsfree mode

During a call, activate or deactivate handsfree mode:

-  Press the handsfree key. Each key press switches between handset and handsfree mode. If handsfree mode is activated, the key is lit up.

If you wish to place the handset in the charger during a call:

- ▶ Press and hold handsfree key  while placing the handset in the base/charger and for a further 2 seconds.

For instructions on adjusting the handsfree volume, → page 32.

Switching to mute



You can deactivate your handset's microphone during a call.

-  Press **right** on the control key to mute the handset. The display shows **Microphone is switched off**. Press the key again to reactivate the microphone.



Making internal calls

Internal calls are free calls between handsets that are registered with the same base.



Calling a specific handset

-  Initiate internal call.
-  Enter the number of the handset.

Or:

-  Initiate internal call.
-  Select handset.
-  Press the talk key.

Calling all handsets (group call)

-  Press and hold.
- Or:
-  Initiate internal call.
-  Press the star key.

Or:

-  Initiate internal call.

Call All Select

-  Press the talk key.

All handsets are called.

Ending a call

-  Press the end call key.

Using the directory and lists

The options are:

- ◆ Directory
- ◆ Redial list
- ◆ Incoming message list (dependent on base)
- ◆ Call list
- ◆ Answering machine list

You can create a personalised directory for your own handset. You can also send lists/entries to other handsets (→ page 26).

Directory

You can save up to 250 entries in the directory.

Please note

To quickly access a number from the directory (shortcut), you can assign the number to a key (→ Using shortcut keys, page 26).

In the **directory**, you can save:

- ◆ Numbers and corresponding names
- ◆ VIP ringer melodies and colours

Open the directory in idle status using the  key.

Length of the entries

Number: max. 32 digits
Name: max. 16 characters

Saving the first number in the directory

 ▶ Dir. empty New Entry?



Enter the number and press **OK**.

Enter the name and press **OK**.

Saving a number in the directory

 ▶ **Menu** ▶ New Entry



Enter the number and press **OK**.

Enter the name and press **OK**.

Order of directory entries

Directory entries are generally sorted alphabetically by surname. Spaces and digits take first priority.

The sort order is as follows:



1. Space
2. Digits (0–9)
3. Letters (alphabetical)
4. Other characters

To work round the alphabetical order of entries, insert a space or a digit before the first letter of the name. These entries will then move to the beginning of the directory.



Selecting a directory entry

 Open the directory.

You have the following options:



- ◆ Use  to scroll through the entries until the required name is selected.
- ◆ Enter the first character of the name; use the  key to scroll to the entry if necessary.

Selecting from the directory

 ▶  (Select entry)

 Press the talk key.

Managing directory entries

 ▶  (Select entry)

Menu Press the display key.

Using the directory and lists

The following functions can be selected with :



VIP Caller Melody

Mark a directory entry as a VIP (Very Important Person) by assigning a specific ringer melody to it. The entry is flagged with the  icon in the directory. VIP calls are recognised by the ringer.



VIP Caller Colour

Mark a directory entry as a VIP (Very Important Person) by assigning a specific colour to it. The entry is displayed in this colour in the address book and marked with the  icon.

Edit Entry

Edit the number if required and press .
Edit the name if required and press .

Use Number

Edit or add to a saved number and then dial it with  or save it as a new entry; to do so, display the number and press:  **Menu** ▶ **Copy to Directory** ▶ 

Delete Entry

Delete selected entry.

Send Entry

Send a single entry to a handset
(→ Transferring the directory to another handset, page 26).

Delete List

Delete all directory entries.

Send List





Send the entire directory to a handset
(→ Transferring the directory to another handset, page 26).

Shortcut

Assign the current entry as a shortcut to a selected key (→ Using shortcut keys, page 26).

Using shortcut keys

You can assign directory entries to the keys  and -:

 ▶  (select entry) ▶  **Menu** ▶ **Shortcut**
▶  (press the key you want to assign the number to)



To dial, press and hold the required shortcut key.



Transferring the directory to another handset

You can transfer directory entries from other handsets to your new handset – even entries from old handsets.

Prerequisites:

- ◆ The sending and receiving handsets must both be registered to the same base.
- ◆ The other handset and the base can send and receive directory entries.

 ▶  (Select entry)
▶  **Menu** (Open menu)
▶ **Send Entry / Send List**

 Select the internal number of the receiving handset and press .

You can transfer several individual entries one after the other by responding to the **Entry copied. Next entry?** prompt with .

A successful transfer is confirmed by a message and confirmation tone on the receiving handset.

Please note:

- ◆ Entries with identical numbers are not overwritten on the receiving handset.
- ◆ The transfer is cancelled if the phone rings or if the memory of the receiving handset is full.
- ◆ VIP melodies and colours assigned to entries are not transferred.

Copying the displayed number to the directory

You can copy numbers displayed in a list e.g., the call list or redial list, to the directory.



A number is displayed:

 **Menu** ▶ **Copy to Directory**

- ▶ Complete the entry (→ Saving a number in the directory, page 25).

Copying numbers from the directory



In some operating situations, you can open the address book e.g., to copy a number. Your handset need not be in idle status.

-  Open the address book.
-  Select an entry and press **OK**.



Using the redial list

The redial list contains the ten numbers last dialled with the handset (max. 32 numbers). If one of the numbers is in the directory, the corresponding name is displayed.

Manual redial

-  Press the key **briefly**.
-  Select entry.
-  Press the talk key again. The number is dialled.

Managing entries in the redial list

-  Press the key **briefly**.
-  Select entry.
- Menu** Open menu.

The following functions can be selected with :

Use Number

(as in the directory, → page 26)

Copy to Directory (→ Saving a number in the directory, page 25)

Delete Entry

Delete selected entry.

Delete List

Delete **all** entries in the redial list.

Message key function

Opening lists

Use the message key  to open the following lists:

- ◆ Answering machine list (dependent on base) or network mailbox, if your network provider supports this function and fast access is set for the network mailbox (→ page 29).
- ◆ Incoming message list (dependent on base)
- ◆ Call list

An advisory tone sounds as soon as a **new message** arrives in a list.

You can select whether the message key  flashes when new messages arrive (default setting):

Menu ▶              **XY** ▶ **OK**

X =  for missed calls

 for new SMS

 for messages on the answering machine

Y =  flashes (it goes off when the key is pressed)

 does not flash

Depending on the type of the new entry, an icon appears in the display while in **idle status**:

Icon **New message ...**

 ... in the answering machine list (Gigaset C300A only) or on the network mailbox

 ... in the **missed calls** list

 ... in the SMS list (dependent on base)

Using the directory and lists

The number of **new** entries is displayed under the corresponding icon.





Please note

If calls are saved in the network mailbox, you will receive a message if the list type has been set accordingly (see your network provider user guide).

After pressing the message key , you can see all lists containing messages and the network mailbox list.

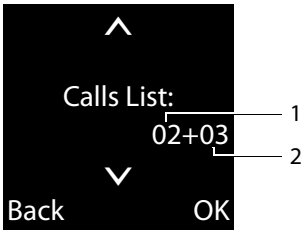
The list is displayed with the number of new entries (1) and the number of old, read entries (2) (example):



Select a list with . To open, press **OK**.

Disable/enable flashing of the message key

You can select whether the message key  flashes (default setting) or does not flash when new messages arrive. Please do the following:

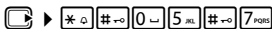

- ▶ Press the key sequence:



The following is displayed:



97

- ▶ Press one of the following keys to select the message type:

 for missed calls
or  for new SMS
or  for messages on the answering machine (dependent on base)/network mailbox

Your selection is displayed (e.g. 5 for missed calls); the current setting flashes:

975 SET: [0]

- ▶ Press key  or , to set the behavior for new messages:

 message key flashes (it stops when the key is pressed)

or  message key does not flash

Your selection is displayed (e.g. 1):

975 SET: [1]

- ▶ Press the display key **OK**.

Incoming message list (dependent on base)

All received SMS messages are saved in the incoming message list.

Call list (dependent on base)

Prerequisite: Calling Line Identification Presentation (CLIP)

Dependent on the base, the call list contains:

- ◆ All calls
 - Accepted calls
 - Unanswered calls
 - Calls recorded by the answering machine (Gigaset C300A only)
- ◆ Or missed calls only
 - Unanswered calls and
 - Calls not recorded by the answering machine (Gigaset C300A only)

In idle status, you can open the call list by pressing the message key .

To return a call, select the corresponding entry and press the talk key .

See your base user guide for further information.

Using the network mailbox

The network mailbox is your provider's voice mail feature within the network. More information is available from your provider.

You cannot use the network mailbox unless you have **requested** it from your provider.

The following information is only applicable when using your handset with a Gigaset C300 base. If you have registered your handset to a different base, such as the Gigaset C300A, please refer to your base user guide.

Using fast access for the network mailbox

To access the answering machine, simply **press and hold** the  key – you do not have to select it via the menu.

You only need to enter the number of the network mailbox.

▶ Voice Mail

▶ Network Mailbox = selected)



Enter the network mailbox number and press **OK**.

The setting for fast access applies to all handsets.

Calling the network mailbox

 Press and hold. You are connected straight to the network mailbox.

Please note

You can also connect to the network mailbox via the menu:

 ▶ Voice Mail ▶ Play Messages

Viewing the network mailbox message

When a message is recorded, you receive a call from the network mailbox. If you have requested Calling Line Identification, the network mailbox number is displayed. If you accept the call, the new messages are played back. If you do not accept the call, the network mailbox number is saved in the missed calls list and the message key flashes (→ page 27).

Please note

Enter the network mailbox phone number into your directory along with the designation "Network mailbox"; the display and the call list will then show this designation.

ECO DECT

You are helping to protect the environment with your Gigaset.

Reducing energy consumption

Your telephone has a power-saving adapter plug and uses less power.

Reducing radiation (dependent on base)

The radiation can only be reduced if your base supports this function.

The transmission power of your telephone is **automatically** reduced depending on the distance to the base.

You can further reduce the radiation from the handset and base by using Eco Mode or Eco Mode+. For further information, please refer to your base user guide.

Using the handset as an alarm clock

Prerequisite: The date and time have already been set.

Activating/deactivating the alarm clock

Menu ▶ Alarm Clock ▶ Activation (☑ = on)

After you activate the alarm clock, the menu for setting the wake up time opens automatically.

The ☺ icon and wake up time are shown on the display.

A wake-up call is signalled on the display (→ page 3) and with the selected ringer volume and melody (→ page 32). The wake-up call sounds for 60 seconds. If no key is pressed, the wake-up call is repeated twice at five-minute intervals and then switched off.

During a call, the wake-up call is only signalled by a short tone.

Setting the wake up time

Menu ▶ Alarm Clock ▶ Wake up time



Enter the wake up time in hours and minutes, then press **OK**.

Deactivating the wake-up call/ repeating after a pause (snooze mode)

Prerequisite: A wake-up call is sounding.

Off

Press the display key. The wake-up call is deactivated.

Or

Snooze

Press the display key or any key. The wake-up call is deactivated and then repeated after 5 minutes. After the second repetition, the wake-up call is deactivated completely.

Handset settings

Your handset is preset, but you can change the settings to suit your individual requirements.

Changing the display language

You can view the display texts in different languages.

Menu ▶ **Settings** ▶ **Language**

The current language is indicated by a .

 Select a language and press **OK**.

If you accidentally choose a language you do not understand:

 ▶  

 Select the correct language and press **OK**.

Setting the display/ screensaver

You have a choice of four colour schemes and several different contrasts. You can also set a screensaver and the backlight.

Menu ▶ **Settings** ▶ **Display**

You have the following options:

Screensaver

You can set a picture or the time to be displayed as a screensaver when the handset is in idle status. This will replace the idle status display. You can choose between **No Screensaver**, **Digital Clock** and **Picture**.

The screensaver is not displayed in certain situations e.g., during a call or if the handset is de-registered.

To show the display in idle status, briefly press end call key .

Colour Schemes

You can set the display to be shown in various colour combinations. Four colour schemes are available.

Contrast

Nine contrast settings are available.

Backlight

Depending on whether or not the handset is in the charger, you can activate or deactivate the backlight ( = on).

If the display backlight **In Charger** is activated, the display is permanently dimmed when the handset is in the charger.

If the display backlight **Out of Charger** is activated, the handset switches the display backlight to 10% of the maximum brightness in 2 stages, when the handset is out of the charger.

When the display backlight is switched off, any key press will activate the backlight and perform the relevant key function.

Please note

If the backlight is turned on outside the charger, the standby time for the handset is considerably reduced!

Activating/deactivating auto answer

If this function is activated, you can simply lift the handset out of the charger without having to press the talk key  when you receive a call.

Menu ▶ **Settings** ▶ **Telephony**

▶ **Auto Answer**

OK Press display key ( = on).

Changing the handsfree/earpiece volume

You can set the volume for handsfree mode and earpiece mode to five different levels.

In idle status:

 ▶ **Call Volume**

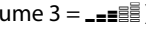

Earpiece Volume / Handsfree Volume

Select and press **OK**.

 Set the volume (e.g., volume 3 = ).

OK Press the display key to save the setting.

During a conversation via the earpiece or in handsfree mode:

 Press the control key to open the menu for setting the volume. Set the earpiece or handsfree volume by pressing .



The setting will automatically be saved after approximately 3 seconds, if not then press the display key **OK**.

Please note

You can also set the call volume using the menu (→ page 22).

Changing ringtones

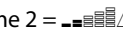
◆ Volume:

You can choose between five volumes (e.g., volume 2 = ) and the "crescendo" ring (volume increases with each ring = .

◆ Ringtones:

You can select a ringer from a list of pre-loaded melodies.

You can set different ringtones for the following functions:

- ◆ Internal calls
- ◆ External calls:
- ◆ Alarm clock

Setting the ringer volume

The ringer volume is the same for all types of ring.

In idle status:

 ▶ **Ringer Volume**

 Set the volume.

OK Press the display key to save the setting.

Please note

You can also adjust the ringer volume via the menu (→ page 22).

Setting the ringer melody

Set different ringer melodies for external calls, internal calls and the alarm clock.



For internal calls and the alarm clock

In idle status:

 ▶ **Ringtones (Handset)**

Internal Calls / Alarm Clock

Select and press **OK**.

 Select melody and press **OK** ( = selected).

For external calls:

In idle status:

 ▶ **Ringtones (Handset)**

External Calls

Select and press **OK**.

 can be used for the following:

Melodies

You can set the ringer melody as described above.

Time Control

You can specify a time period when you do not want the telephone to signal external calls e.g., during the night.

Activation is switched on or off by pressing **OK** ( = activated)

Settings

Ringer off from: / Ringer off until:

Enter time in 4-digit format.

Please note

During this period, you will continue to receive calls from numbers to which you have assigned a personalised melody in the directory (VIP).

Anonymous Calls Silent

You can set your handset so that it doesn't ring for calls where Calling Line Identification has been withheld (not answering machine). The call will only be signalled on the display.

Switch the **Anonymous Calls Silent** function on or off by pressing **OK** (= activated).

Please note

You can also set the ringer melodies via the menu (→ page 22).

Activating/deactivating the ringer

You can:

- ◆ Permanently deactivate the ringer in idle status or when receiving a call
- ◆ Deactivate the ringer for the current call only.

The ringer cannot be re-activated while a call is in progress.

Deactivating the ringer permanently

Press and **hold** the star key.

The  icon appears in the display.

Reactivating the ringer

Press and **hold** the star key.

Deactivating the ringer for the current call

Menu ▶ **Silent** ▶ **OK**

Activating/deactivating advisory tones/battery warning tones

Your handset uses advisory tones to tell you about different activities and statuses. These can be activated and deactivated independently of each other:

- ◆ **Advisory Tones**
 - **Confirmation tone:** at the end of an entry/setting and when an SMS or a new entry arrives in the call list
 - **Error tone:** when you make an incorrect entry
 - **Menu end tone:** when scrolling to the end of a menu
 - **Key click:** every key press is confirmed.
- ◆ **Battery Low**

The battery requires charging.

▶ **Advisory Tones / Battery Low**

Select and press **OK** to activate or deactivate (= activated).

Changing the base

If your handset is registered to more than one base, you can set it to a particular base or to the base that has the best reception (**Best Base**).

Menu ▶ **Settings** ▶ **Registration**
▶ **Select Base**

 Select one of the bases or **Best Base** and press **OK**.

Restoring the handset default settings

You can reset individual settings and changes that you have made.

The following settings are **not** affected by a reset:

- ◆ Registration of the handset to the base
- ◆ Date & time
- ◆ Entries in the directory, call lists, SMS lists

Menu ▶ **Settings** ▶ **System** ▶ **Reset Handset**

OK Confirm prompt.

Service (Customer Care)

You have questions? As a Gigaset customer, you can take advantage of our comprehensive service offerings. You can find help quickly in this User Manual and in the service pages of our Gigaset online portal.

Please register your phone right after purchase.

This enables us to provide you with even better service regarding questions or a warranty claim. Your personal user account enables you to directly contact our customer service by email.

Our representatives are available on the telephone hotlines for more advanced questions or immediate consultation.

United Kingdom

www.gigaset.com/uk/service

Service Hotline: 0845 367 0812

(local call cost charge)

Ireland

www.gigaset.com/ie/service

Service Hotline: 1850 777 277

(6.6561 Ct./Call)

Please note that if the Gigaset product is not sold by authorised dealers in the national territory the product may not be fully compatible with the national telephone network. It is clearly specified on the box near the CE mark as well as on the bottom of the base station for which country/countries the equipment has been developed. If the equipment is used in a manner inconsistent with this advice or with the instructions of the manual and on the product itself, this may have implications on the conditions for warranty or guarantee claims (repair or exchange of product).

In order to make use of the warranty, the product purchaser is asked to submit a receipt which proves the date of purchase (date from which the warranty period starts) and the type of goods that have been purchased.

Questions and answers

If you have any queries about the use of your telephone, visit our website at www.gigaset.com/service for assistance 24/7.

The table below contains a list of common problems and possible solutions.

The display is blank.

1. The handset is not switched on.
 - › Press and **hold** the end call key .
2. The battery is empty.
 - › Charge the battery or replace it (→ page 10).

"Base" flashes on the display.

1. The handset is outside the range of the base.
 - › Move the handset closer to the base.
2. The base's range is reduced because Eco Mode is activated.
 - › Deactivate Eco Mode (→ page 30) or reduce the distance between the handset and the base.
3. The base is not switched on.
 - › Check the base power adapter.
4. Handset has not been registered with the base or has been de-registered.
 - › Register the handset (→ page 12).

Handset does not ring.

1. The ringer is deactivated.
 - › Activate the ringer (→ page 33).
3. The phone only rings if the phone number has been transferred.
 - › Activate the ringer for unknown calls (→ page 33).

Each incoming call resets the date/time incorrectly.

The date and time are sent via e.g., your network provider, a router or PABXs during calling line display. This data may be incorrect.

- › Set the date/time correctly e.g., on the router or PABX.
- › Do not automatically copy the date/time (dependent on base, refer to base user guide).

The connection always terminates after approx. 30 seconds.

Repeater activated/deactivated.

- › Activate/deactivate the handset (→ page 19).

The other party cannot hear you.

You pressed the mute key  during a call. The handset is "muted".

- › Unmute the microphone (→ page 24).

The number of the caller is not displayed despite CLIP.

Calling Line Identification is not enabled.

- › **The caller** should ask the network provider to enable Calling Line Identification (CLI).

You hear an error tone when keying an input.

Action has failed/invalid input.

- › Repeat the process.
Watch the display and refer to the user guide if necessary.

Exclusion of liability

Some displays may contain pixels (picture elements), which remain activated or deactivated. As a pixel is made up of three sub-pixels (red, green, blue), it is possible that pixel colours may vary.

This is completely normal and does not indicate an error.

Authorisation

This device is intended for use within the European Economic Area and Switzerland. If used in other countries, it must first be approved nationally in the country in question.

Country-specific requirements have been taken into consideration.

We, Gigaset Communications GmbH, declare that this device meets the essential requirements and other relevant regulations laid down in Directive 1999/5/EC.

A copy of the 1999/5/EC Declaration of Conformity is available at this Internet address:

www.gigaset.com/docs

 0682

Guarantee Certificate United Kingdom

Without prejudice to any claim the user (customer) may have in relation to the dealer or retailer, the customer shall be granted a manufacturer's Guarantee under the conditions set out below:

- ◆ In the case of new devices and their components exhibiting defects resulting from manufacturing and/or material faults within 24 months of purchase, Gigaset Communications shall, at its own option and free of charge, either replace the device with another device reflecting the current state of the art, or repair the said device. In respect of parts subject to wear and tear (including but not limited to, batteries, keypads, casing), this warranty shall be valid for six months from the date of purchase.
- ◆ This Guarantee shall be invalid if the device defect is attributable to improper treatment and/or failure to comply with information contained in the user guides.
- ◆ This Guarantee shall not apply to or extend to services performed by the authorised dealer or the customer themselves (e. g. installation, configuration, software downloads). User guides and any software supplied on a separate data medium shall be excluded from the Guarantee.
- ◆ The purchase receipt, together with the date of purchase, shall be required as evidence for invoking the Guarantee. Claims under the Guarantee must be submitted within two months of the Guarantee default becoming evident.
- ◆ Ownership of devices or components replaced by and returned to Gigaset Communications shall vest in Gigaset Communications.
- ◆ This Guarantee shall apply to new devices purchased in the European Union. For Products sold in the United Kingdom the Guarantee is issued by: Gigaset Commu-

nications UK Limited, Quatro House, Lyon Way, Camberley, Surrey, GU16 7ER.

- ◆ Any other claims resulting out of or in connection with the device shall be excluded from this Guarantee. Nothing in this Guarantee shall attempt to limit or exclude a Customers Statutory Rights, nor the manufacturer's liability for death or personal injury resulting from its negligence.
- ◆ The duration of the Guarantee shall not be extended by services rendered under the terms of the Guarantee.
- ◆ Insofar as no Guarantee default exists, Gigaset Communications reserves the right to charge the customer for replacement or repair.
- ◆ The above provisions does not imply a change in the burden of proof to the detriment of the customer.

To invoke this Guarantee, please contact the Gigaset Communications telephone service. The relevant number is to be found in the accompanying user guide.

Guarantee Certificate Ireland

Without prejudice to any claim the user (customer) may have in relation to the dealer or retailer, the customer shall be granted a manufacturer's Guarantee under the conditions set out below:

- ◆ In the case of new devices and their components exhibiting defects resulting from manufacturing and/or material faults within 24 months of purchase, Gigaset Communications shall, at its own option and free of charge, either replace the device with another device reflecting the current state of the art, or repair the said device. In respect of parts subject to wear and tear (including but not limited to, batteries, keypads, casing), this warranty shall be valid for six months from the date of purchase.

- ◆ This Guarantee shall be invalid if the device defect is attributable to improper care or use and/or failure to comply with information contained in the user manuals. In particular claims under the Guarantee cannot be made if:
 - ◆ The device is opened (this is classed as third party intervention)
 - ◆ Repairs or other work done by persons not authorised by Gigaset Communications.
 - ◆ Components on the printed circuit board are manipulated
 - ◆ The software is manipulated
 - ◆ Defects or damage caused by dropping, breaking, lightning or ingress of moisture. This also applies if defects or damage was caused by mechanical, chemical, radio interference or thermal factors (e.g.: microwave, sauna etc.)
 - ◆ Devices fitted with accessories not authorised by Gigaset Communications
 - ◆ This Guarantee shall not apply to or extend to services performed by the authorised dealer or the customer themselves (e.g. installation, configuration, software downloads). User manuals and any software supplied on a separate data medium shall be excluded from the Guarantee.
 - ◆ The purchase receipt, together with the date of purchase, shall be required as evidence for invoking the Guarantee. Claims under the Guarantee must be submitted within two months of the Guarantee default becoming evident.
 - ◆ Ownership of devices or components replaced by and returned to Gigaset Communications shall vest in Gigaset Communications.
 - ◆ This Guarantee shall apply to new devices purchased in the European Union. For Products sold in the Republic of Ireland the Guarantee is issued by Gigaset Communications UK Limited, Quatro House, Lyon Way, Camberley, Surrey, GU16 7ER.
- ◆ Any other claims resulting out of or in connection with the device shall be excluded from this Guarantee. Nothing in this Guarantee shall attempt to limit or exclude a Customers Statutory Rights, nor the manufacturer's liability for death or personal injury resulting from its negligence.
- ◆ The duration of the Guarantee shall not be extended by services rendered under the terms of the Guarantee.
- ◆ Insofar as no Guarantee default exists, Gigaset Communications reserves the right to charge the customer for replacement or repair.
- ◆ The above provisions does not imply a change in the burden of proof to the detriment of the customer.

To invoke this Guarantee, please contact the Gigaset Communications helpdesk on 1850 777 277. This number is also to be found in the accompanying user guide.

Protecting our environment

Our environmental mission statement

We, Gigaset Communications GmbH, bear social responsibility and are actively committed to a better world. Our ideas, technologies and actions serve people, society and the environment. The aim of our global activity is to secure sustainable life resources for humanity. We are committed to a responsibility for our products that comprises their entire life cycle. The environmental impact of products, including their manufacture, procurement, distribution, use, service and disposal, are already evaluated during product and process design.

Further information on environmentally friendly products and processes is available on the Internet at www.gigaset.com.

Environmental management system



Gigaset Communications GmbH is certified pursuant to the international standards EN 14001 and ISO 9001.

ISO 14001 (Environment): certified since September 2007 by TÜV SÜD Management Service GmbH.

ISO 9001 (Quality): certified since 17/02/1994 by TÜV SÜD Management Service GmbH.

Ecological energy consumption

The use of ECO DECT (→ page 30) saves energy and makes an active contribution towards protecting the environment.

Disposal

Batteries should not be disposed of in general household waste. Observe the local waste disposal regulations, details of which can be obtained from your local authority.

All electrical and electronic products should be disposed of separately from the municipal waste stream via designated collection facilities appointed by the government or the local authorities.



This crossed-out wheeled bin symbol on the product means the product is covered by the European Directive 2002/96/EC.

The correct disposal and separate collection of your old appliance will help prevent potential negative consequences for the environment and human health. It is a precondition for reuse and recycling of used electrical and electronic equipment.

For more detailed information about disposal of your old appliance, please contact your local council refuse centre or the original supplier of the product.

Appendix

Caring for your telephone

Wipe the unit with a **damp cloth** or an **anti-static cloth**. Do not use solvents or microfibre cloths.

Never use a dry cloth. This can cause static.

Contact with liquid

If the handset should come into contact with liquid:

1. **Switch the handset off and remove the batteries immediately.**
2. Allow the liquid to drain from the handset.
3. Pat all parts dry, then place the handset with the battery compartment open and the keypad facing down in a dry, warm place **for at least 72 hours** (not in a microwave, oven etc.).
4. **Do not switch on the handset again until it is completely dry.**

When it has fully dried out, you will usually be able to use it again.

Specifications

Batteries

Technology:

Nickel-metal-hydride (NiMH)

Size: AAA (Micro, HR03)

Voltage: 1.2 V

Capacity: 550 - 1000 mAh

The device is supplied with two approved batteries.

Handset operating times/charging times

This Gigaset can charge batteries up to a capacity of 1000 mAh. The use of special high-performance batteries or batteries with high capacities is not recommended for cordless phones.

The operating time of your Gigaset depends on the capacity and age of the batteries and the way they are used. (All times are maximum possible times).

	Capacity (mAh) approx.			
	550	700	800	1000
Standby time (hours) *	255/ 89	295/ 103	340/ 118	420/ 146
Talktime (hours)	14	16	19	23
Operating time for 1.5 hrs of calls per day (hours) **				
- Without Eco Mode+	120	140	160	195
- With Eco Mode+	80	95	110	135
Charging time in charger (hours)	5.5	6.5	7.5	9

*) Without/with display backlight

**) Without display backlight
(Backlight → page 31)

Due to the constant progression in battery development, the list of recommended batteries in the FAQ section of the Gigaset Customer Care pages is regularly updated:

www.gigaset.com/service

General specifications DECT

DECT standard	Is supported
GAP standard	Is supported
No. of channels	60 duplex channels
Radio frequency range	1880–1900 MHz
Duplex method	Time multiplex, 10 ms frame length
Repeat frequency of the transmission pulse	100 Hz
Length of the transmission pulse	370 µs
Channel grid	1728 kHz
Bit rate	1152 kbit/s
Modulation	GFSK
Language code	32 kbit/s
Transmission power	10 mW, average power per channel 250 mW pulse power
Range	up to 300 m outdoors, up to 50 m indoors
Environmental conditions in operation	+5°C to +45°C, 20% to 75% relative humidity
Dialling mode	DTMF (tone dialling)/ PD (pulse dialling)

Pin connections on the telephone jack

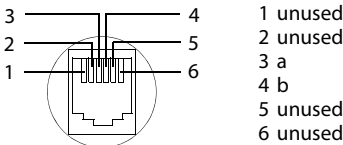

Writing and editing text

The following rules apply when writing text:

- ◆ Multiple letters and characters are assigned to each key between **0** and **9** as well as ***** and **#**.
- ◆ Control the cursor with **←** **→** **↶** **↷**.

- ◆ Characters are inserted at the cursor position.
- ◆ Press the display key **Del** to delete the **character** to the left of the cursor.
- ◆ The first letter of the name of directory entries is automatically capitalised and followed by lower case letters.

Setting upper/lower case or digits

Repeatedly press the hash key **#** to change the text input mode.

123	Writing digits
Abc	Upper case *
abc	Lower case

* First letter in capitals, all others in lower case

When the mode is switched, the active mode is indicated at the bottom left of the screen.

Writing an SMS/names

- ▶ Enter the individual letters/characters by pressing the corresponding key.

The characters assigned to the key are shown in a selection line at the bottom left of the screen. The selected character is highlighted.

- ▶ **Briefly** press the key several times in succession to select the required letter/character.

Standard characters

	1x	2x	3x	4x	5x	6x	7x	8x	9x	10x	11x	12x	13x	14x	15x	16x
1 _{iso}	1	€	£	\$	¥	¤										
2 _{abc}	a	b	c	2	ä	á	à	â	ã	ç						
3 _{def}	d	e	f	3	ë	é	è	ê								
4 _{ghi}	g	h	i	4	ï	í	ì	î								
5 _{jkl}	j	k	l	5												
6 _{mno}	m	n	o	6	ö	ñ	ó	ò	ô	õ						
7 _{pqr}	p	q	r	s	7	ß										
8 _{tuv}	t	u	v	8	ü	ú	ù	û								
9 _{wxyz}	w	x	y	z	9	ÿ	ý	æ	ø	ã						
0 ₁₂₃₄₅₆₇₈₉	1)	.	,	?	!	2)	0	+	-	:	;	‘	”	’	;	_
* ₀₁₂₃₄₅₆₇₈₉	*	/	()	<	>	%									
# ₀₁₂₃₄₅₆₇₈₉	#	@	\	&	§											

1) Space

2) Line break

Accessories



Use only original accessories. This will avoid possible health risks and personal injury, and also ensure that all the relevant regulations are complied with.

Mounting the charger on the wall

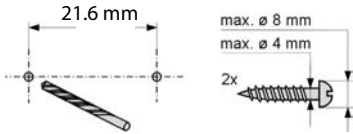

Approx. 1.3 mm

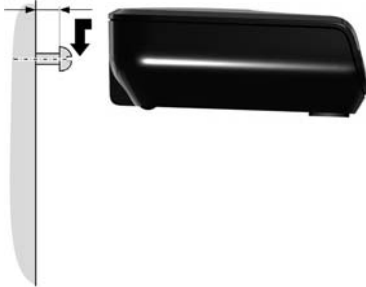

Index

A

- Accepting a call 23
- Accessories 42
- Activating
 - auto answer 31
 - handset 19
 - keypad lock 19
- Advisory tones 33
 - confirmation tone 33
 - error tone 33
 - key click 33
- Alarm clock 30
- Answering machine list 27
- Authorisation 35
- Automatic
 - auto answer 31
- Automatic auto answer 23, 31

B

- Backlight 31
- Battery
 - charging 2, 3
 - display 2, 3
 - icon 2, 3
 - inserting 10
 - tone 33
- Battery warning tone 33
- Best base 33

C

- Call
 - ending 23
 - external 23
 - internal 24
- Call duration 23
- Call lists 28
- Calling
 - external 23
 - internal 24
- Caring for your telephone 39
- Changing
 - display language 11, 31
 - earpiece volume 32
 - handsfree volume 32
 - ringer 32
- Changing the base 33
- Character set 41

- Charge status display 2, 3
- Colour scheme 31
- Confirmation tone 33
- Contrast 31
- Correcting incorrect entries 17
- Customer Care 34

D

- Deactivating
 - auto answer 31
 - handset 19
 - keypad lock 19
- Delete key 4
- Deleting
 - characters 17
- Dialling
 - using shortcuts 26
 - using the directory 25
- Digital clock 31
- Directory 25
 - copying number from text 26
 - managing entries 25
 - opening 17
 - order of entries 25
 - saving entry 25
 - saving the first number 25
 - sending entry/list to handset 26
 - using to enter numbers 27
- Display
 - backlight 31
 - changing display language 11, 31
 - colour scheme 31
 - contrast 31
 - in idle status 15, 18
 - network mailbox message 29
 - screensaver 31
 - setting 31
- Disposal 38

E

- Earpiece volume 32
- ECO DECT 30
- End call key 2, 23
- Ending
 - call 23
- Entry
 - saving (network mailbox) 29
 - selecting from directory 25
- Error tone 33

Index

F	
Fast access	
network mailbox.....	29
Flashing of the message key	
disable/enable.....	28
G	
General troubleshooting.....	35
Group call.....	24
Guarantee Certificate.....	36
H	
Handset	
activating/deactivating.....	19
changing to a different base.....	33
changing to best reception.....	33
contact with liquid.....	39
de-registering.....	13
display language.....	11, 31
earpiece volume.....	32
handsfree volume.....	32
idle status.....	18
list.....	17
muting.....	24
registering.....	12
restoring to default settings.....	33
set up for use.....	10
Hash key.....	2, 19
Hearing aids.....	7
Help.....	35
I	
Icon	
alarm clock.....	30
for new messages.....	27
keypad lock.....	19
ringer.....	33
Idle status	
returning to.....	18
Idle status (display).....	15, 18
Incorrect entries (correction).....	17
Internal call.....	24
K	
Key 1 (fast access).....	2
Key click.....	33
Keypad lock.....	19
Keys	
assigning directory entry.....	26
control key.....	2, 17
delete key.....	4
display keys.....	2, 4
end call key.....	2, 23
hash key.....	2, 19
message key.....	2
on/off key.....	2
recall key.....	2
shortcut.....	26
star key.....	2
talk key.....	2, 23
L	
Language	
display.....	11, 31
List	
answering machine.....	27
call lists.....	28
handsets.....	17
missed calls.....	28
network mailbox.....	27
SMS incoming list.....	27
Lock	
activating/deactivating keypad lock ..	19
M	
Making calls	
accepting a call.....	23
external.....	23
internal.....	24
Making internal calls.....	24
Manual redial.....	27
Medical equipment.....	7
Menu	
end tone.....	33
overview.....	22
using.....	18
Message key.....	2
disable/enable flashing.....	28
opening lists.....	27
Microphone.....	2
Missed call.....	28
Muting the handset.....	24

- N**
- Network mailbox..... 29
 - Number
 - copying from directory 27
 - copying to the directory 26
 - entering netw. mailbox number..... 29
 - entering with directory 27
 - saving in directory 25
- O**
- On/Off key.....2
 - Order in directory 25
- P**
- Package contents8
 - Pin connections 40
 - Power adapter7
 - power saving 30
 - Power saving adapter plug..... 30
 - Protecting our environment..... 38
- Q**
- Questions and answers 35
- R**
- Range9
 - Recall key.....2
 - Redial 27
 - Reducing energy consumption..... 30
 - Reducing radiation 30
 - Ring delay 31
 - Ringer
 - changing..... 32
 - setting melody..... 32
 - setting volume..... 32
- S**
- Screen protection, see Screensaver
 - Screensaver..... 31
 - Search directory 25
 - Sending
 - directory entry to handset 26
 - Service 34
 - Setting melody (ringer) 32
 - Setting the date..... 14, 22
 - Setting the time..... 14, 22
 - Setting the wake up time 30
- Setting up
 - charger9
 - handset 10
- Setting up the charger.....9
- Shortcut..... 25, 26
- SMS**
- incoming list 27
 - writing 40
- Snooze mode..... 30
- Sound, see Ringer
- Specifications..... 39
- Star key2
- T**
- Talk key 2, 23
 - Telephone jack
 - pin connections 40
 - Time control 32
- U**
- Unknown calls 33
 - Using handsfree mode 24
 - Using the control key 2, 17
 - Using the display keys 2, 4
- V**
- Viewing network mailbox message 29
 - Volume
 - earpiece..... 32
 - handset handsfree volume..... 32
 - ringer 32
- W**
- Writing and editing text 40

