

# EUREKA

We live and breathe clean.™

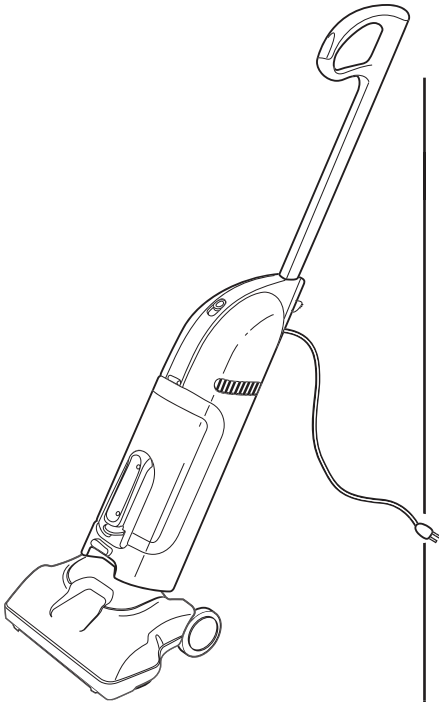

## Lightweight Upright Household Type OWNER'S GUIDE 400 Series

### IMPORTANT

Do **not** return this product to the store.  
For assembly problems or questions  
contact: Eureka's Customer Service  
Division toll free at 1-800-282-2886\*, 8  
a.m. to 7:30 p.m., (CST), Monday -  
Friday and 10 a.m. to 6:30 p.m. Saturday.

\*En Mexico llame al 5670-6169

[www.eureka.com](http://www.eureka.com)

### Index

Important Safeguards .....	2
Service Information .....	4
Assembly .....	5-6
Use & Dust Cup .....	7
Brush Roll & Blockages .....	8
Customer Order Form .....	9
Warranty .....	11

### PLEASE RETAIN

We suggest you record the model, type and serial numbers below. They are located on the silver rating plate on your cleaner. For prompt and complete service information, always refer to these numbers when inquiring about service.

Model & Type \_\_\_\_\_  
Serial No. \_\_\_\_\_

It is also important to keep your receipt as proof of date of purchase.

# IMPORTANT SAFEGUARDS

When using an electric appliance, basic precautions should always be followed, including the following:

## READ ALL INSTRUCTIONS BEFORE USING THIS VACUUM CLEANER

### WARNING

To reduce the risk of fire, electric shock, or injury:

- Do not use outdoors or on wet surfaces.
- **Do not leave vacuum cleaner when plugged in.** Turn off the switch and unplug the electrical cord when not in use and before servicing.
- Do not allow to be used as a toy. Close attention is necessary when used by or near children.
- Use only as described in this manual. Use only manufacturer's recommended attachments.
- Do not use with damaged cord or plug. If vacuum cleaner is not working as it should, has been dropped, damaged, left outdoors, or dropped into water, return it to a service center before using.
- Do not pull or carry by cord, use cord as a handle, close a door on cord or pull cord around sharp edges or corners. Do not run vacuum cleaner over cord. Keep cord away from heated surfaces.
- Do not use extension cords or outlets with inadequate current carrying capacity.
- Turn off all controls before unplugging.
- Do not unplug by pulling on cord. To unplug, grasp the plug, not the cord.
- Do not handle plug or vacuum cleaner with wet hands.
- Do not put any object into openings. Do not use with any opening blocked; keep free of dust, lint, hair, and anything that may reduce airflow.
- This vacuum cleaner creates suction and contains a revolving brush roll. Keep hair, loose clothing, fingers, and all parts of body away from openings and moving parts.
- Do not pick up anything that is burning or smoking, such as cigarettes, matches, or hot ashes.
- Do not use without dust cup filter in place.
- Use extra care when cleaning on stairs.
- Do not use to pick up flammable or combustible liquids such as gasoline, or use in areas where they may be present.
- Store your cleaner indoors in a cool, dry area.
- Keep your work area well lighted.
- Unplug electrical appliances before vacuuming them.

## SAVE THESE INSTRUCTIONS

To reduce the risk of electric shock, this appliance has a polarized plug (one blade is wider than the other). This plug will fit in a polarized outlet only one way. If the plug does not fit fully into the outlet, reverse the plug. If it still does not fit, contact a qualified electrician to install the proper outlet. Do not change the plug in any way.

## GENERAL INFORMATION

Use the cleaner to pick up dirt and dust particles. Avoid picking up hard or sharp objects that could damage the vacuum cleaner.

## Service Information

The instructions in this booklet serve as a guide to routine maintenance. For additional service information, telephone our toll free number for the nearest Eureka Authorized Warranty Station. **You should know the model, type and serial number or date code when you call:**

**USA: 1-800-282-2886**  
**Mexico: 5670-6169**  
**Canada: 1-800-282-2886**

If you prefer, you can write to Electrolux Home Care Products North America, Service Division, 807 North Main Street, Bloomington, Illinois 61701, USA. In Canada write to Electrolux Home Care Products Canada, 866 Langs Drive, Cambridge, Ontario N3H 2N7. Refer to The Eureka Warranty for complete service information.



**DO NOT OIL the motor or the brush roll. The motor and brush roll are permanently sealed and lubricated.**

## Rating Plate

The rating plate on the back of the vacuum cleaner shows the model number. For prompt and complete service, always refer to these numbers.

Model and Type No. \_\_\_\_\_

Serial No. or Date Code \_\_\_\_\_

<b>THE EUREKA COMPANY</b> BLOOMINGTON, ILLINOIS 61701 USA HOUSEHOLD TYPE		
MODEL	TYPE	SERIAL #

## CE Rating System (Cleaning Effectiveness per Amp)

This is not an Amp rating. Amps do not measure dirt removal, only the amount of electricity used. Cleaning Effectiveness per Amp is determined by dividing this model's Cleaning Effectiveness by its Amps. CLEANING EFFECTIVENESS is the perfect value obtained from dividing:

- the geometric mean of the amount of embedded carpet dirt removed in testing under ASTM Test Method F608-97 by
- the value 29 (the geometric mean of the midpoints of the % dirt pick up scales chosen as a reference for the rating system).

# Identify Parts

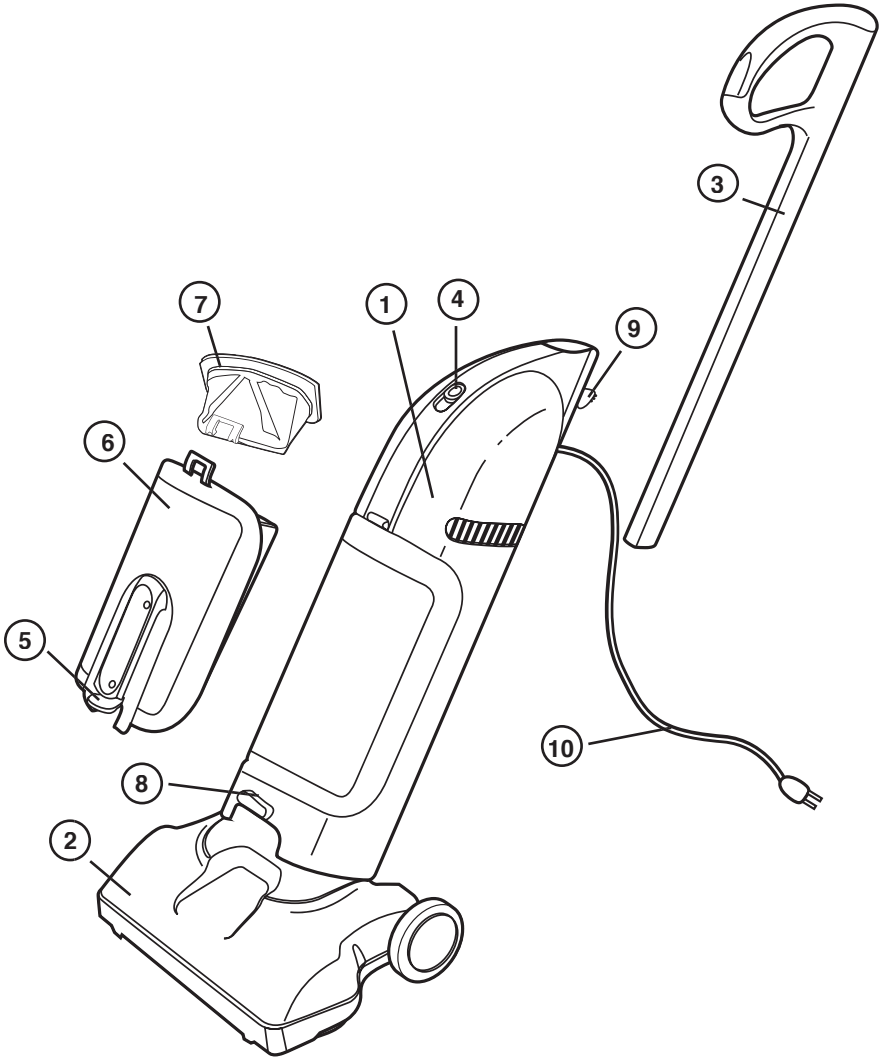

- 1. Body
- 2. Floor Nozzle
- 3. Handle
- 4. On/Off Switch
- 5. Dust Cup Latch
- 6. Dust Cup
- 7. Filter Assembly
- 8. Stair Cleaning Hand Grip
- 9. Handle Button
- 10. Electrical Cord

# HOW TO ASSEMBLE

## Attach Handle

1. Locate the handle and body.
2. Line the handle up with the hole in the top of the body. Flat side of handle and loop forward.
3. Push handle down into body while pressing button on back of the body. Handle will click into place.
4. There are two handle positions available. Handle all the way up and handle all the way down.
5. Button needs to be depressed to raise and lower the handle.

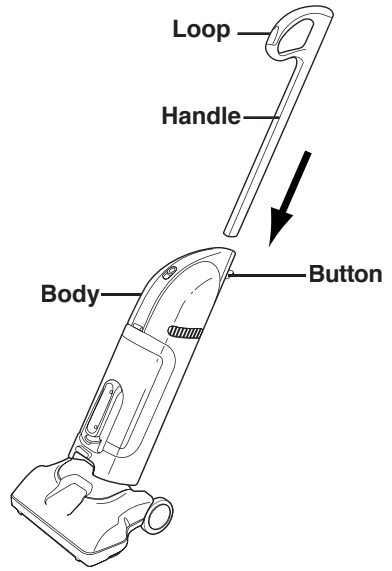

# HOW TO USE

## Power Switch

The power switch has three positions. Off, Floor (hard surface cleaning) and Carpet.

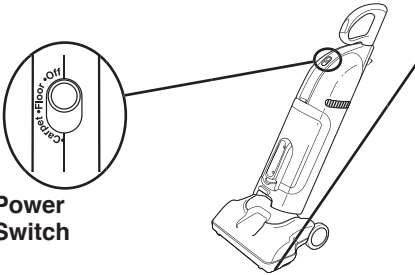

Power Switch

## Nozzle with Edge Kleener®

Airflow under the nozzle automatically directs suction to the edges and corners for maximum full width cleaning.

Experiment with your hard floor surfaces, sometimes it is best to have brush roll turning. (Switch in the carpet position).

## Dual Uses

Push the handle button to release lock. The handle will slide freely until it finds one of the two available handle positions. It automatically locks in either of these two positions.

With the handle collapsed, the unit is great for stairs and compact storage. With the handle extended, the unit is great for floor cleaning.



## HOW TO MAINTAIN

The instructions given in this booklet serve as a guide to routine maintenance. Keep the cleaner operating at top efficiency. Empty the dust cup after each use.

 **NOTE:** Turn off the power switch and unplug the electrical cord to service.

### Empty Dust Cup

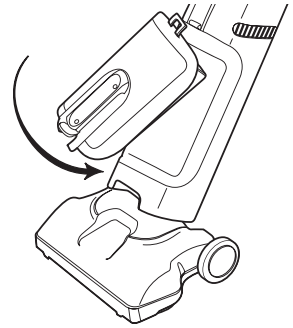
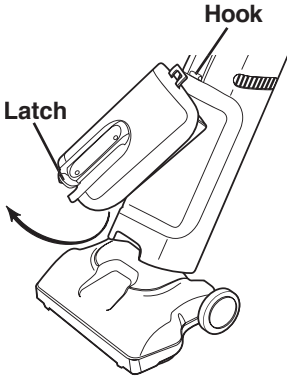



1. Pull dust cup latch up.
2. Swing dust cup out from body and up off the dust cup hook on the body.
3. Remove dust cup filter from the dust cup, shake contents of dust cup into a waste container.
4. To replace dust cup, fit dust cup down onto hook.
5. Swing down and push gently into body until dust cup clicks into place.

### Clean Dust Cup Filter

**Clean the dust cup filter as necessary.**

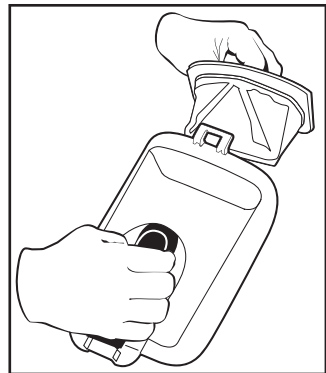
1. Remove dust cup.
2. Grasp handle inside filter and pull filter out of dust cup.
3. Shake and brush the dust and dirt from filter.
4. To replace filter, push filter into dust cup so that flexible rim of filter fits securely into dust cup.
5. If desired, remove filter from frame, launder the filter by hand in warm water using a mild detergent.
6. Air dry thoroughly.
7. Replace filter on frame and reinstall in dust cup.



 **NOTE:** The dust cup filter is not dishwasher safe. Do not put in dishwasher.

Replace a dirty or torn filter. Order additional dust cup filters from The Eureka Company, Bloomington, IL 61701. Order dust cup filter, part number 60958.

## HOW TO MAINTAIN (continued)

### Brush Roll

**NOTE:** Turn off switch and unplug the electrical cord before inspecting brush roll.

Long hair, thread, string, etc. can wrap around the revolving brush roll and result in reduced performance.

To check brush roll for debris turn cleaner nozzle over and inspect for wrapped matter. Use scissors to cut debris from brush roll.

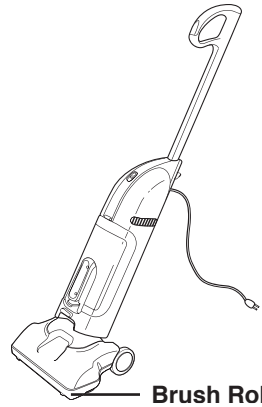

### How to Check for Blockages

**NOTE:** Turn off switch and unplug the electrical cord before checking for blockages.

If suction performance diminishes, check for blockages in suction path.

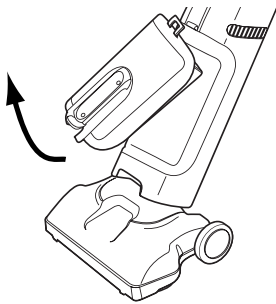

1. Remove dust cup and set aside.

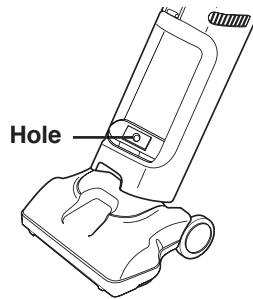

2. Inspect for blockages inside hole area at base of body opening. Use tool or coat hanger to remove blockage.

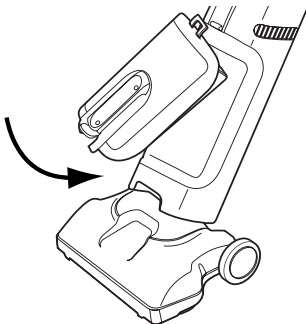

3. Reinstall dust cup.

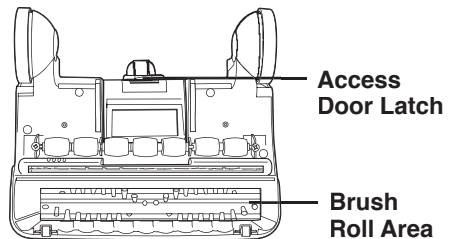

4. Flip vacuum over and inspect dirt channel in brush roll area. Open access door by pulling back on access door latch and lifting up, check for blockage. Remove any blockages with tool or coat hanger.

# THE EUREKA LIMITED WARRANTY

## *What This Warranty Covers*

Your Eureka cleaner is warranted to be free from all defects in material and workmanship in normal household use for a period of one year. The warranty is granted only to the original purchaser and members of his or her immediate household. The warranty is subject to the following provisions.

## *What This Warranty Does Not Cover*

- Parts of the cleaner that require replacement under normal use, such as disposable dust bags, filters, drive belts, light bulbs, and brush roll bristles, impellers and cleaning.
- Damages or malfunctions caused by negligence, abuse, or use not in accordance with the Owner's Guide.
- Defects or damages caused by unauthorized service or the use of other than Genuine Eureka parts.

## *What the Manufacturer Will Do*

The manufacturer will, at its option, repair or replace a defective cleaner or cleaner part that is covered by this warranty. As a matter of warranty policy, the manufacturer will not refund the consumer's purchase price.

## *Warranty Registration*

Please fill out and return the warranty registration card accompanying your cleaner.

## *Obtaining Warranty Service*

To obtain warranty service you must return the defective cleaner or cleaner part along with proof of purchase to any Eureka Authorized Warranty Station.

You will find the nearest location in the Yellow Pages, under "Vacuum Cleaners - Service and Repair." Be certain that the Warranty Station is "Eureka Authorized."

For the location of the nearest Eureka Authorized Warranty Station or for service information, telephone toll free:

**USA: 1-800-282-2886**

**Mexico: 5670-6169**

**Canada: 1-800-282-2886**

If you prefer, you can write to Electrolux Home Care Products North America, Service Division, 807 North Main Street, Bloomington, Illinois 61701, USA. In Canada write to Electrolux Home Care Products Canada, 866 Langs Drive, Cambridge, Ontario N3H 2N7.

If it is necessary to ship the cleaner outside your community to obtain warranty repair, you must pay the shipping charges to the Eureka Authorized Warranty Station.

Return shipping charges will be paid by the Warranty Station. When returning parts for repair, please include the model, type, and serial number from the data plate on the cleaner.

## *Further Limitations and Exclusions*

Any warranty that may be implied in connection with your purchase or use of the cleaner, including any warranty of Merchantability or any warranty for Fitness For A Particular Purpose is limited to the duration of this warranty. Some states do not allow limitations on how long an implied warranty lasts, so the above limitations may not apply to you.

Your relief for the breach of this warranty is limited to the relief expressly provided above. In no event shall the manufacturer be liable for any consequential or incidental damages you may incur in connection with your purchase or use of the cleaner. Some states do not allow the exclusion or limitation of incidental or consequential damages, so the above limitation or exclusion may not apply to you.

This warranty gives you specific legal rights. You may also have other rights which vary by state.

**GENUINE**  
EUREKA PRODUCT

## *Questions & Answers about Genuine Eureka Products*

**Q:** Why should I use only Genuine Eureka paper bags, belts, and parts in my Eureka vacuum cleaner?

**A:** Using Genuine Eureka Products, which are made to exacting specifications and engineered with emphasis on quality, performance, and customer satisfaction, ensures the long life and cleaning efficiency of your vacuum cleaner. Overall, this saves you money and helps to keep your home clean.

**Q:** How can I be sure I am using only genuine Eureka products in my vacuum cleaner?

**A:** Typically, packaged products and paper bags can be identified by a "Genuine Eureka Product" symbol (see illustration above). For further identification assistance, you may call our toll-free number, 1-800-282-2886, for the location of a nearby Eureka Authorized Warranty Station.

**Q:** Are there any differences between "made to fit" or "imitation" and Genuine Eureka paper bags, belts, and parts?

**A:** Yes, there are some very important differences in materials, quality, and reliability. Many customers have mistakenly purchased "imitation" paper bags and parts while thinking they purchased genuine. Unfortunately, many of these customers discovered the differences after they experienced related difficulties.

**For Genuine Eureka Value, Accept No Imitations!**