



OPERATOR AND PARTS MANUAL

Loader

Models 495, S495

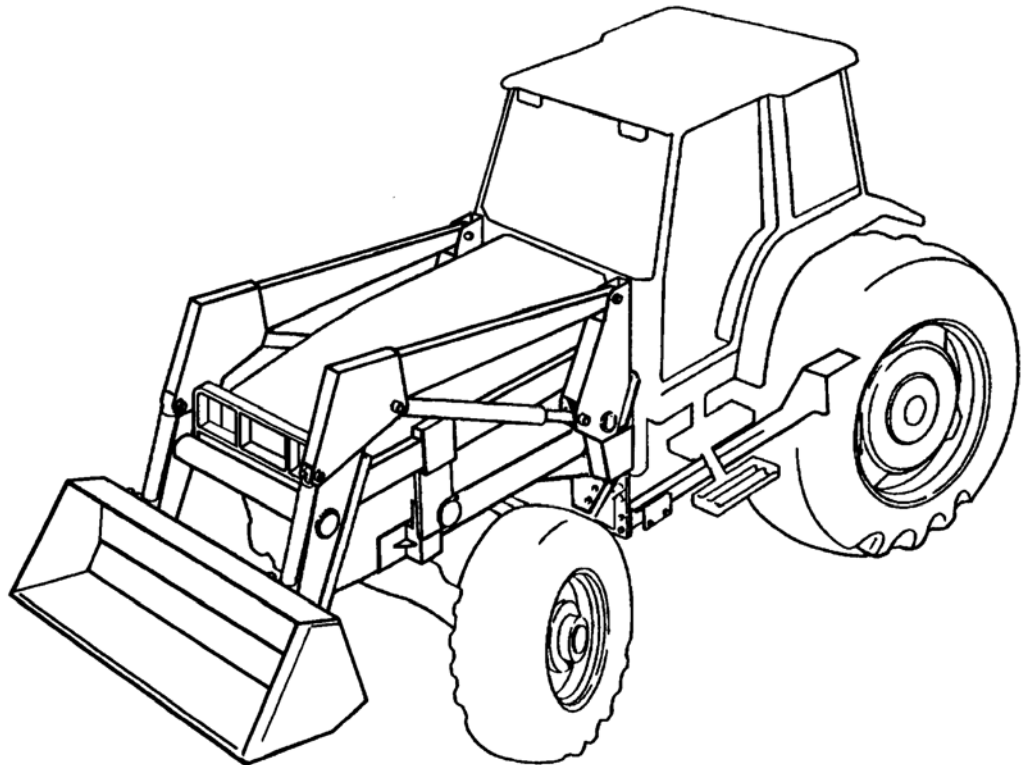

Table of Contents

- Introduction4**
 - Terminology4
 - Hydraulic (Hose Kit)5
- Specifications.....6**
- Safety.....8**
 - Safety8
 - General Safety9
 - Installation9
 - Safety Decals 10
 - Important Precautions 11
- Operation12**
 - Operation.....12
 - Operating Suggestions for Loading13
 - Operating Suggestions for Backfilling14
 - Attaching the Loader to Your Tractor.....15
 - Removing the Loader from Your Tractor.....17
- General Instructions19**
- TSL General Note and Instructions.....20**
- Troubleshooting.....22**
- Maintenance21**
 - Lubrication21
- Bolt Torque25**
 - Checking Bolt Torque25
- Parts.....26**
 - Sub Frame Assembly and Parts List.....26
 - Main Frame Assembly and Parts List28
 - Hydraulic Plumbing Assembly and Parts List.....30
- Assembly.....32**
 - Hydraulic Cylinder Assembly.....32
- Pre-delivery Check List.....33**
- Warranty.....34**

Manufacturer’s statement: for technical reasons Buhler Industries Inc. reserves the right to modify machinery design and specifications provided herein without any preliminary notice. Information provided herein is of descriptive nature. Performance quality may depend on soil fertility, applied agricultural techniques, weather conditions and other factors.

Introduction

Allied by Farm King front-end loaders are backed by years of extensive research. Factory testing simulates specific operations to evaluate durability; days of continuous cycling in raising, twisting and dropping loads using a programmed hydraulic power unit represents years of extreme use. With one of the largest mounting kit application lists in the industry, there is an Allied front-end loader available for nearly every tractor, large or small, new or old. Custom colors are available to match all tractor brands which adds resale value and visual appeal.

Keep this manual handy for frequent reference. All new operators or owners must review the manual before using the equipment and at least annually thereafter. Contact your Allied by Farm King Dealer if you need assistance, information, or additional copies of the manual. Visit our website at www.buhlerindustries.com for a complete list of dealers in your area.

The directions left, right, front and rear, as mentioned throughout this manual, are as seen facing in the direction of travel of the implement.

Terminology

Basic terminology used throughout this manual has been identified below. For part numbers and further details refer to the Parts section.

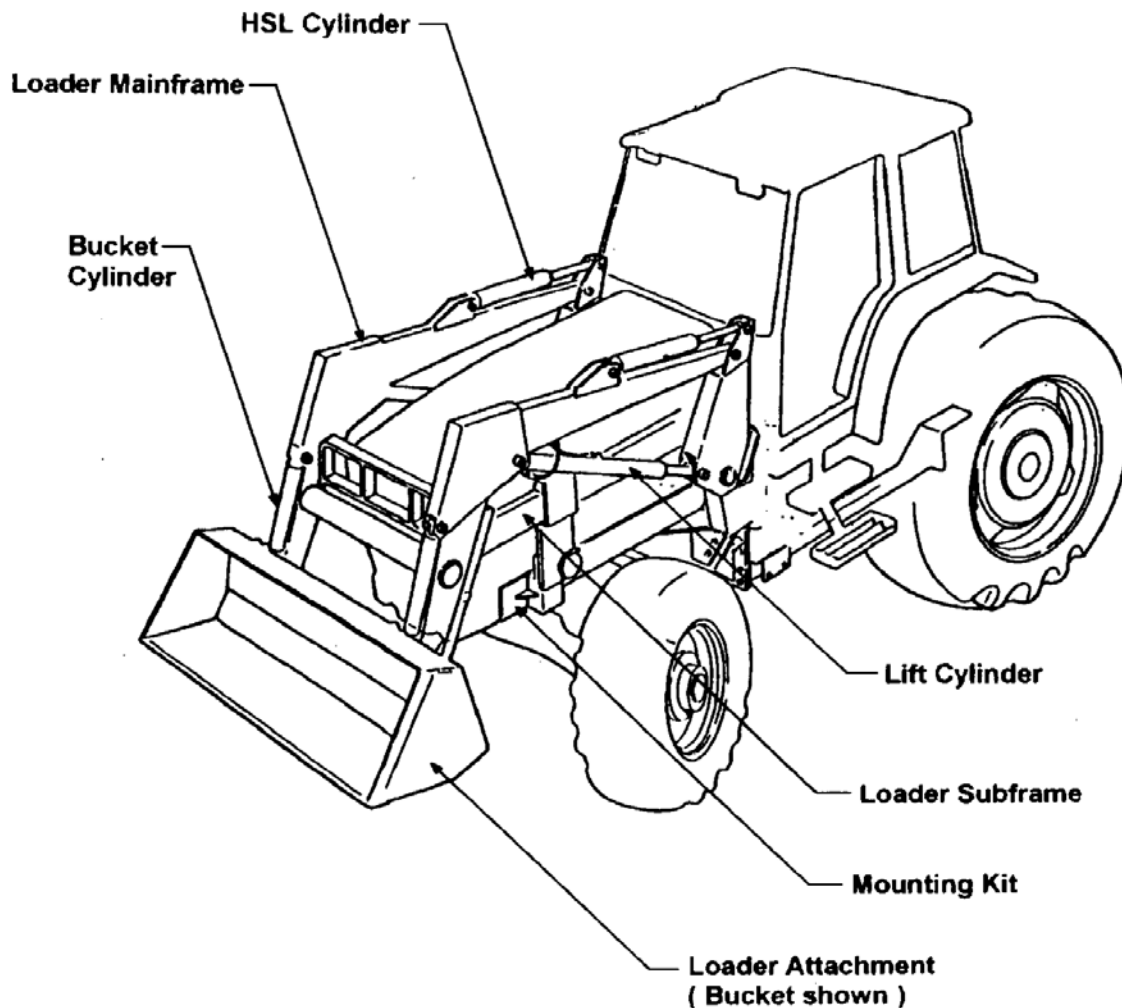

Hydraulic (Hose Kit)

Hose Kit "A"

Loader powered by the tractor remotes.

Consists of four hoses leading from loader tubing to tractor remote couplers

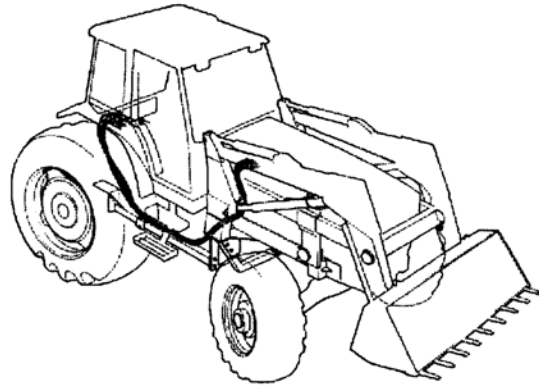

Hose Kit "B"

Loader operated by an external OC or CC valve that is powered from the tractor remotes.

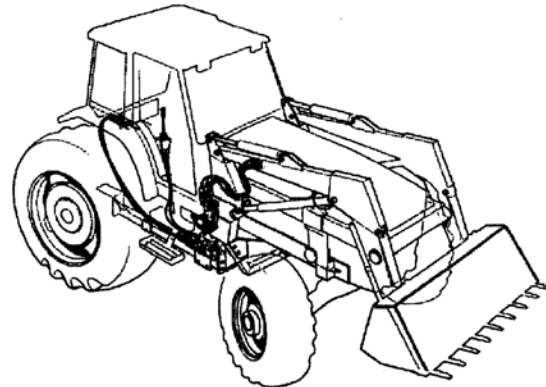

Hose Kit "C"

Loader operated by an external valve that is plumbed into the tractor hydraulic system.

Consists of 4 hoses leading from loader tubing to external mounted valve plus the necessary fittings, hoses and adapter blocks (if necessary) to tap into tractor hydraulic system. Use valve type shown with hose kit "C"

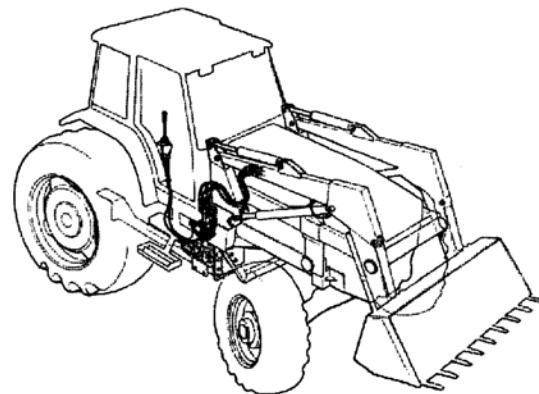

Specifications

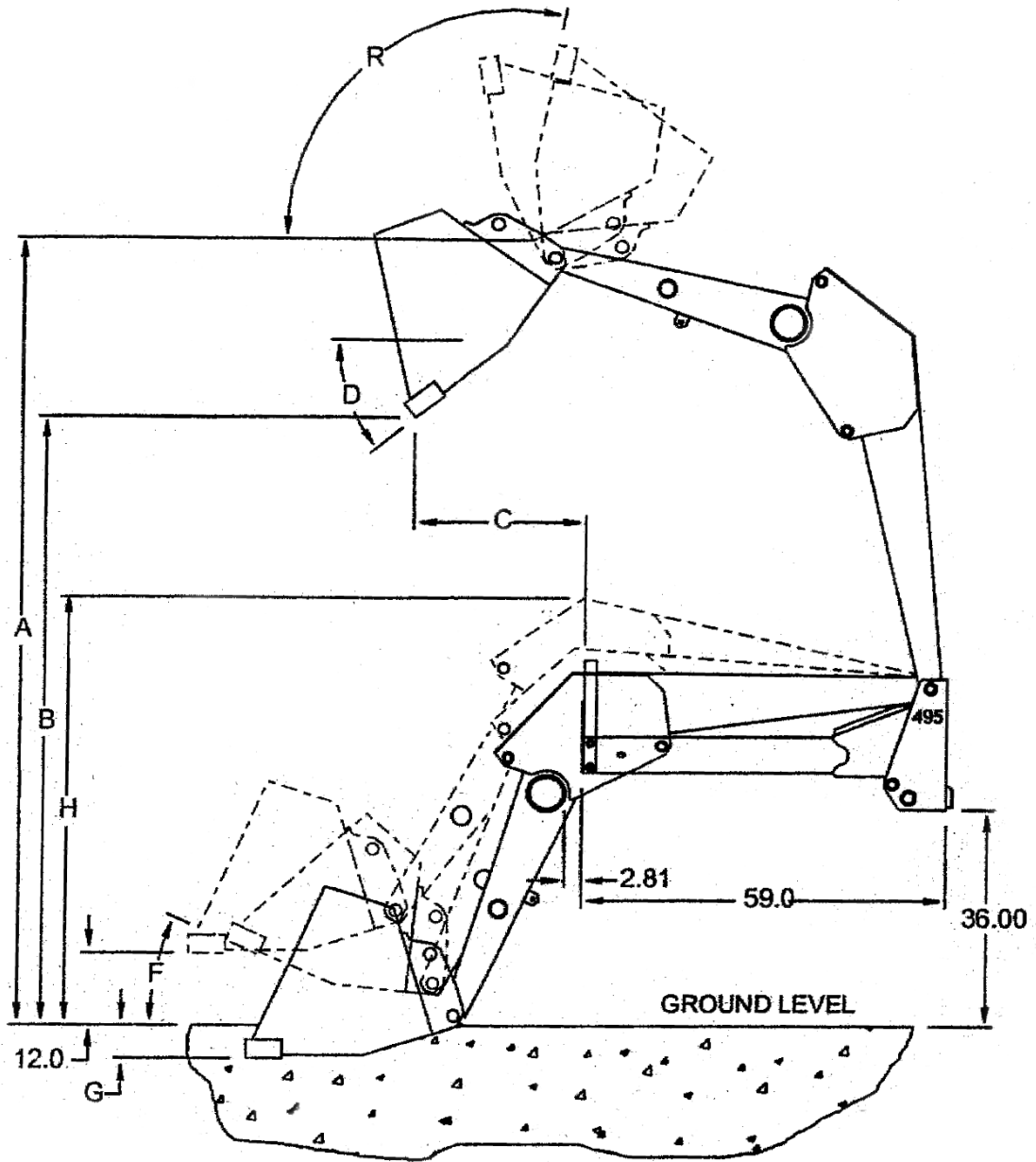

Model number: 495

Mounting height: 36" (nominal)

Typical range: 33" - 39"

Description	Bucket	Lift
Bore	2.50"	2.50"
Rod	1.50"	1.50"
Stroke	20.63"	20.63"

A - Maximum lift height to pivot point (full height): 130" (11.0')

B - Clearance with bucket dumped: 100.4" (8.4')

C - Reach at maximum height: 28.2"

D - Maximum dump angle: 38°

F - Bucket rollback angle: 23.4°

G - Digging depth: 5.5"

H - Overall height in carry position: 70.7" (5.9')

R - Rollback angle at full height: 102.1°

Calculated breakout force: 2500 lbs with 2.5" lift cylinders

Calculated lift capacity: 2075 lbs with 2.5" lift cylinders

Notes:

- 1 - Calculated values assume 2500 psi lift cylinder pressure
- 2 - Breakout force estimated as per ASAE S301.2 - 4.1.2 (net payload applied at cutting edge)
- 3 - Lift capacity estimated a per ASAE S301.2 - 4.1.1 (net payload applied at bucket midpoint)
- 4 - Average bucket weight (72"): 450 lbs
- 5 - Optional 3" lift cylinders available
- 6 - Short models breakout approx. 10% more than corresponding reg. models

Safety

Safety Instructions

Remember, YOU are the key to safety. Good safety practices not only protect you, but also the people around you. Make these practices a working part of your safety program. Be certain that everyone operating this equipment is familiar with the recommended operating and maintenance procedures and follows all the safety precautions. Most accidents can be prevented. Do not risk injury or death by ignoring good safety practices.

The alert symbol is used throughout this manual. It indicates attention is required and identifies hazards. Follow the recommended precautions.



The safety alert symbol means...
ATTENTION! BECOME ALERT! YOUR SAFETY IS INVOLVED!



CAUTION

The caution symbol indicates a potentially hazardous situation that, if not avoided, may result in minor or moderate injury. It may also be used to alert against unsafe practices.



WARNING

The Warning Symbol indicates a potentially hazardous situation that, if not avoided, could result in death or serious injury, and includes hazards that are exposed when guards are removed. It may also be used to alert against unsafe practices.



DANGER

The Danger Symbol indicates an imminently hazardous situation that, if not avoided will result in death or serious injury. This signal word is to be limited to the most extreme situations, typically for machine components that, for functional purposes, cannot be guarded.

General Safety Instructions

- Have a first-aid kit available for use and know how to use it.
- Have a fire extinguisher available, stored in a highly visible location, and know how to use it.
- Wear appropriate protective gear. This list may include but is not limited to:
 - hard hat
 - protective shoes with slip resistant soles
 - protective glasses or goggles
 - heavy gloves
 - wet weather gear
 - hearing protection
 - respirator or filter mask
- Read and understand the Operator's Manual and all safety signs before operating, servicing, adjusting, repairing, or unplugging the equipment.
- Never work beneath raised loader unless it is securely supported. The following are instructions for the lift lock supports.
- Do not pivot or turn tractor with bucket raised, except at a minimum speed. Always make allowance for length of loader when making turns.
- Never leave tractor unattended while the bucket is raised. Always lower bucket to the ground and shut off before leaving the tractor seat.
- Do not walk under raised bucket.
- Never operate loader while operator is not seated in the driver's seat on the tractor.
- Keep tractor on solid ground. Loose fill, rocks and holes can be dangerous for loader operation or movement.
- Never operate a loader with frayed or damaged hoses or leaking fittings.
- Add ballast as required to ensure 25% of gross vehicle weight is transferred to the rear axle.
- Space rear tires as recommended by tractor manufacturer. Maximize width for high lift applications.
- Do not raise bucket to extreme heights while tractor is on an incline. Carry loader low for safety. Load center when bucket is raised on a slope. Be alert for terrain changes and adjust bucket accordingly. Keep bucket low, no more than one foot high, as long as possible.
- Note: A pivoting front axle acts like a three-wheeled tractor until the stops hit the axle.
- If the cylinders are used to raise front wheels of tractor for service, place blocks under tractor before working around front end.

Installation

- To install safety signs, ensure the installation area is clean and dry. Decide on the exact position before you remove the backing paper. Remove the smallest portion of the split backing paper and align over the specified area. Carefully press in place.
- Slowly peel back the remaining paper and smooth the remaining portion in place. Small air pockets can be pierced with a pin and smoothed out.

Safety Decals

 **WARNING**



OVERHEAD HAZARD
*STAY AWAY FROM UNDER LIFT
ARMS AND BUCKET*

To prevent serious injury or death:

1. Do not stand or work under raised loader, unless supported.
2. Support bucket and lift arms before working under loader.
3. Lower loader to the ground before leaving seat.

 **CAUTION**

1. Read Operator's Manual before operating.
2. Move and turn tractor at low speed.
3. Carry loader arms at a low position during transport.
4. Lower loader arms, stop engine and lock brakes before leaving operator seat.
5. Do not stand or work under raised loader, unless properly supported.
6. Add recommended wheel ballast or rear weight for stability.
7. Move wheels to widest recommended settings to increase stability.
8. Do not handle large round bales or other shiftable objects unless loader is equipped with a grapple fork.
9. Do not use loader to move or carry people.
10. Stay away from power lines. Electrocution can occur without direct contact.
11. Review safety instructions annually.

Important Precautions

⚠ DANGER

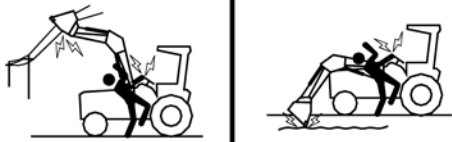

ELECTROCUTION HAZARD
To prevent serious injury or death:

Stay away from power lines and cables.
Electrocution can occur with or without direct contact.

⚠ WARNING



FALLING HAZARD
To prevent serious injury or death:

Do not lift, carry or allow anyone to ride on or work from any portion of loader.

⚠ WARNING



CRUSHING HAZARD
To prevent serious injury or death:

Do not handle round bales or other shiftable objects unless loader is equipped with an attachment designed for this purpose.
Do not handle loose loads that are not secured.
Do not lift load higher than necessary.

⚠ WARNING

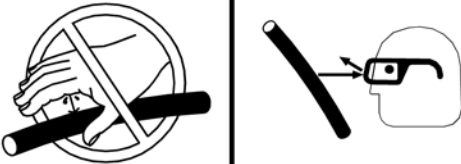

HIGH PRESSURE FLUID
To prevent serious injury or death:

Relieve pressure on system before repairing or adjusting or disconnecting.
Wear proper hand and eye protection when searching for leaks. Use wood or cardboard instead of hands.
Keep all components in good repair.
If hydraulic fluid penetrates skin, obtain medical treatment IMMEDIATELY.

⚠ WARNING



ROLL-OVER HAZARD
To prevent serious injury or death:

Move and turn tractor at low speed.
Carry load no higher than necessary to clear the ground when transporting.
Add wheel ballast or rear weight for stability.
Move wheels to widest possible settings to increase stability.
It is recommended the tractor be equipped with a rollover protective structure (ROPS).

⚠ WARNING



CRUSHING HAZARD
To prevent serious injury or death:

Do not allow bystanders in loader work area.
Lower loader to the ground before leaving seat.
Do not walk or work under raised loader. For servicing, refer to operator's manual.
Read and understand operator's manual before operating loader.

Operation

Operation

General Operating Notes:

Refer to tractor Operator's Manual for Operating information on the tractor's hydraulic system.

Hydraulic systems using auxiliary valves should have them located for easy reach from the tractor seat. Hoses should be connected in such a manner that pushing forward on valve handles lowers the boom or dumps the bucket



WARNING

Always connect boom hoses to float section.

Weight added to rear of tractor provides better traction and an easier, more efficient loader operation. Extra weight along with the rear wheels, reduces the risk of roll-over.

The smaller the tractor is, the easier it will roll. We recommend that weight be added to rear tires with liquid or by the installation of rear wheel weights. Where additional weight is required, a counterweight box can be fabricated for tractors with three-point hitches.

Extra weight can also be added by the use of a heavy implement mounted to the three-point hitch.

A roll-over protective structure is also recommended.

In cold weather, operate the tractor's engine at idle speed until the hydraulic fluid is warmed up. High engine speed when the hydraulic fluid is cold will cause the pump to wear prematurely.

Under normal conditions, operate the tractor's engine at 1/2 throttle. Shift the tractor into a low gear before entering a pile of material to minimize strain on loader arms.

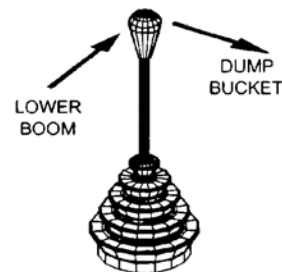
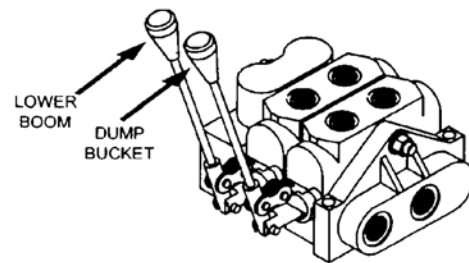

Operating Suggestions for Loading

When handling heavy loads, be sure to lower lift arms slowly. This is known as feathering the hydraulic lever. If load is lowered too fast and stopped suddenly, excessive shock loads are created which can damage loader or tractor.

When loading bucket, drive straight into material. Attempting to turn tractor while loading bucket can cause damage to both the loader and tractor.

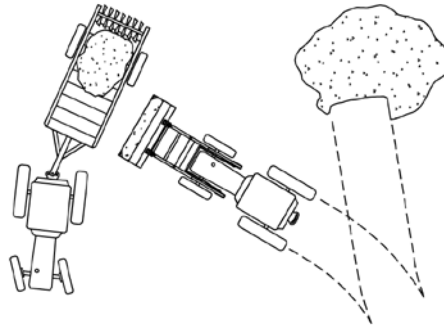
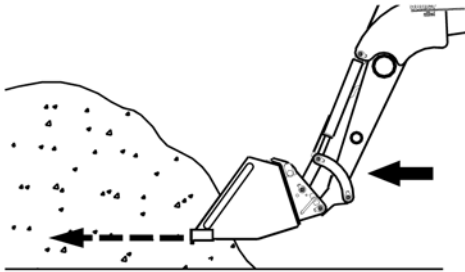

Note: Bottom surface of bucket is parallel to line on motion.

To increase loading efficiency, minimize angle of turn and length to run between pile and spreader.

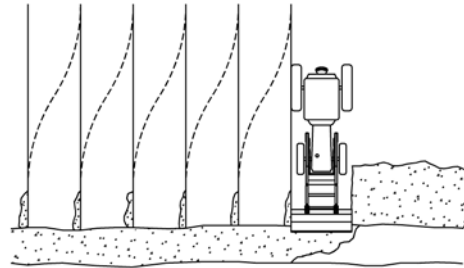
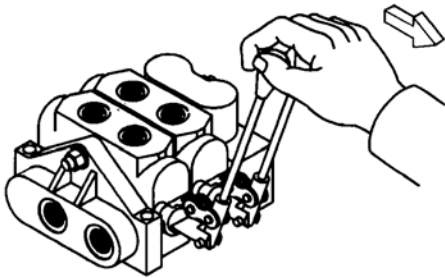

Work both levers back to direct pressure to both cylinders.

Leave material, which drifts over the bucket sides for final cleanup.

Combined action of lift and bucket cylinders increases loading efficiency.

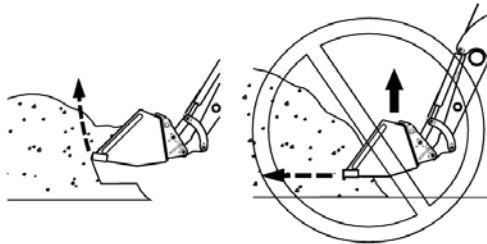

A straight bottom offers more resistance to lift.

Operating Suggestions for Backfilling

DO THIS

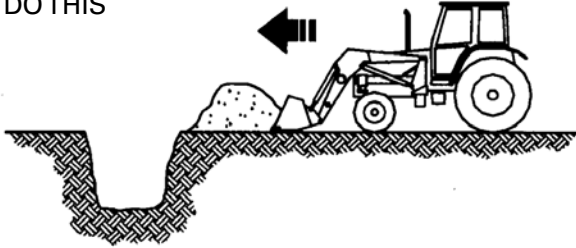

When backfilling approach pile with a flat bucket. Leave dirt in bucket. Dumping on each pass wastes time.



Backgrade work surface with a loaded bucket. Release all pressure on lift cylinders so full weight of bucket is scraping ground. Use heel of bucket

NOT THIS!

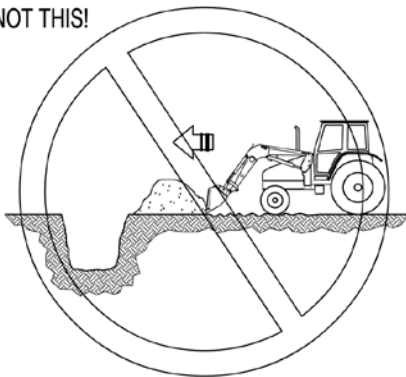

Do not use bucket in dumped position for bulldozing. This will only impose severe shock loading on the bucket cylinders and make it more difficult to maintain a level grade.



WARNING Do not use loader as battering ram!

Attaching the Loader to Your Tractor

1. Position the tractor as centrally as possible and drive, using lowest gear possible, into the loader frame until hoses can be connected.
2. Couple up the hydraulic hose lines to the loader or tractor valve ensuring proper function (see operator and maintenance section)

NOTE: When mounting the loader for the first time, slowly work the cylinders back and forth, so that most of the air is removed. Loosen the bolts on the hooks so that they can be moved. Also, check that the nuts in the rear of the subframe are in line with the holes.

3. On some tractors, the lift cylinders may have to be extended slightly, so that the subframes can clear the front axle. Do not extend the cylinders more than is required.

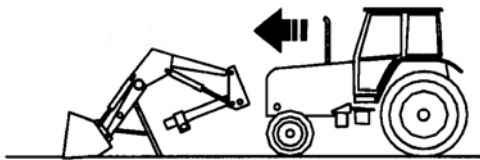

On self leveling loaders, the bucket will dump at the same time the loader is raised. Therefore, Operate both hydraulic levers together.

4. Drive the tractor ahead until the subframe is past the front axle and the front hook is close to mounting boss.

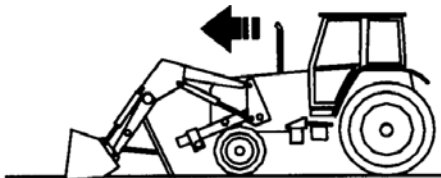

Check front grille clearance during installation to avoid tractor damage.

5. Retract or extend the lift cylinders to line up the front hook with the mounting boss.



On self leveling loaders, the bucket will roll back at the same time the loader is lowered. Therefore, operate both hydraulic levers together.

6. When the hook is lined up, dump or roll back the bucket to lower or raise the subframe upright to align with the mounting boss.



7. Continue to drive the tractor forward until the subframe uprights are seated in the boot.

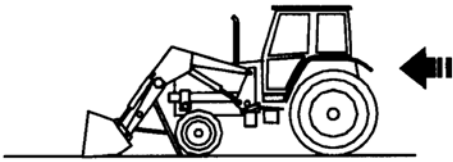

8. Secure the subframe uprights with the bolts and washers. Torque 500 ft-lb.

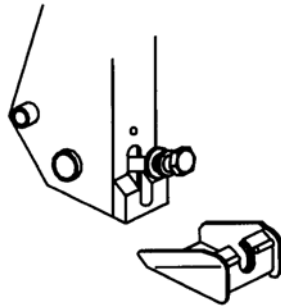

When mounting for the first time, the front hook bolts will have to be tightened after positioning the hook directly over the mounting boss (most rearward position)

9. Raise the loader and lock the support stand tubes in the up position.

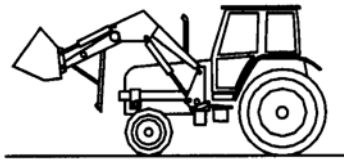

When mounting for the first time, raise the loader slowly and check to make sure that the hoses do not bind or become pinched in all positions. Work the loader and bucket up and down to work out all the air in the hydraulics. Check and refill the tractor's hydraulic system.

Removing the Loader from Your Tractor



WARNING

When removing the loader, it must be fitted with a bucket or other suitable attachment to give the frame stability after removal. If this is not done, the frame will not remain standing.



WARNING

Always remove the loader on firm, level ground (away from children's play area and high traffic areas). This makes attaching and removing much faster and easier. It also makes the free standing loader more stable.

1. Raise the loader, lower support stand tubes and lock into position.

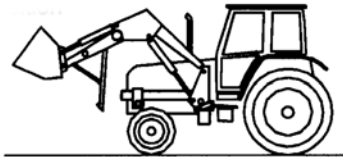

2. Lower the loader until the stand tubes are firmly on the ground and then dump the bucket so that it is also firmly on the ground. there should be slight downward pressure.

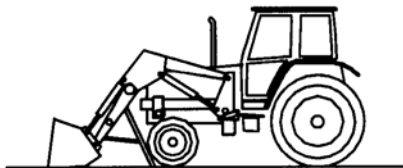

3. Loosen the bolts from the rear of the subframe boots and swing bolt up into lock position.

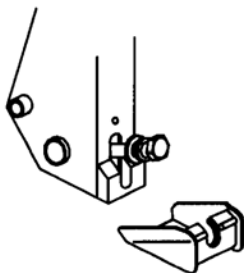

4. Roll back the bucket slightly and simultaneously extend or retract the lift cylinders to free hooks from spools. Then slowly back up the tractor.

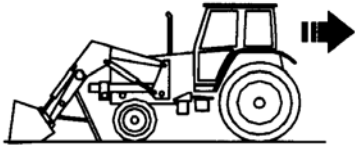

5. Once the subframe is clear of the boot and the hook is clear of the mounting boss, roll back the bucket all the way. This raises the rear uprights of the loader.

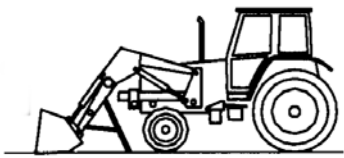

On some mountings, the lift cylinders must be extended more while the tractor is backing up, so that the subframes clear the front axle.

6. Continue backing up until the loader is clear.

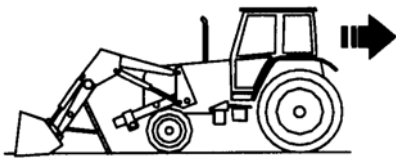

Be sure the hoses do not get pinched or catch on any frame members while backing up.

7. After the loader is clear, retract the lift cylinders to protect the shafts and disconnect the hydraulic lines at quick couplers.

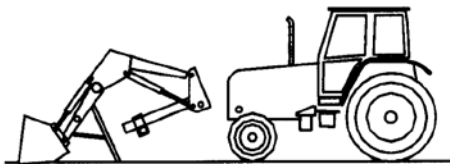

General Instructions

As with any piece of equipment, the care with which your loader is operated and maintained will greatly affect its life and the safety of the people using it.

1. Keep all pivots well lubricated for longer bushing life. Inspect every 500 hours of operation for wear.
2. Periodically check all bolts for tightness. If any bolt is damaged, replace it with a bolt of equivalent grade or strength.
3. Follow the recommendations of the tractor manufacturer in regards to the quantity of oil used.
4. Check oil level frequently to ensure the system is full.
5. When making an oil check, be sure lift cylinders are retracted.
6. Before operating the loader, particularly if the loader is left standing for any length of time, check the hydraulic system and oil level.
7. When installing hydraulics, follow the circuit carefully. See hydraulic hook-up section and make sure the hoses do not contact any hot manifolds or sharp edges on tractor. After assembly, raise the loader slowly and check to make sure that the hoses do not bind in all positions.
8. The pressure of the relief and open center valves is set at the factory. Do not tamper with the setting, serious injury to the operator or damage to the loader or tractor hydraulics may occur. Warranty will be void if the loader is operated above recommended pressure.
9. When servicing any hydraulic components, care must be taken to prevent any foreign matter from entering the system.
10. Do not neglect oil leaks. Leaks affect loader operation, are dangerous and can result in personal injury or damage to the hydraulic system.
11. Never leave the cylinder shafts exposed when loader is not in use.
12. Worn or damaged components should be replaced as soon as possible with only the manufacturer's recommended component or equivalent.

TSL General Note and Instructions

1. The true self leveling system (TSL) utilizes mechanical linkages to maintain bucket level while raising and lowering. The pivot plate weldment, leveling tubes and linkages have been developed to ensure that the bucket remains at the same position throughout its range of motion. This feature is standard with 2.50" and 3.00" diameter bucket cylinders.
2. The TSL system incorporates a relief and anticavitation manifold to provide extra dump at ground and rollback at full lift height. This feature is available on 3.00" bucket cylinders only. If the loader is raised with the bucket fully dumped, oil from the bucket piston side will be bypassed at high pressure to the bucket shaft side and the lift shaft side as the quickattach contacts the dump stop. If the loader is lowered with the bucket fully rolled back, oil from the bucket shaft side will be bypassed at high pressure to the bucket piston side and the lift piston side will provide makeup as the quick attach contact the rollback stop. Note that these two conditions are likely to occur intermittently and although the pump will be forced to supply oil at a higher pressure, no damage to the loader components will occur. It is, however, recommended to avoid the above situations and keep the bucket somewhat level while raising or lowering the loader for smoother operation.
3. The extra bucket stroke length allows for the bucket to be dumped to approximately 90° at ground. This allows for bucket assist when traction is minimal. If the loader is raised from this position, the bucket will retract as the quick attach contacts the dump stop and the circuit goes through relief as described in note 2.
4. Extra bucket retraction allows for the bucket to be rolled back as the loader raises. The TSL feature maintains the bucket level, but as required the bucket can be manually rolled back approximately 20° to allow for increased bucket capacity. If the loader is lowered from this position, the bucket will extend as the quick attach contacts the rollback stop and the circuit goes through relief as described in note 2.
5. The relief valve is factory set at 3250 PSI cracking pressure and is capable of bypassing 10-15 GPM. If loader lock-up should occur due to a low tractor relief setting, higher inlet flows or return line restrictions, the relief valve may be backed off slightly until the lock-up condition is overcome (counterclockwise turn of set-screw). Contact the factory for further instructions.

Troubleshooting

Problem	Possible Cause	Remedy	
Loader slow and/or will not dump	Quick couplers leaking	Check connections and compatibility or replace	
	Hydraulic oil too heavy	Change or replace filter	
	Oil filter plugged	Clean or replace filter	
	Hydraulic pump worn	Repair or replace pump	
	Oil line restricted or leaking		Check all hoses and tubes for leaks, damage or restrictions
			Replace damaged or restricted hoses or tube lines
	Control valve does not shift properly	Inspect, clean, repair or replace valve	
	Air in hydraulic system	Cycle lift cylinders and bucket cylinders several times to free system of air	
	Cylinder leaks internally	Replace seals	
Faulty valve	Repair or replace valve		
Loader chatters or vibrates when raising and lowering	Air leak in pump inlet line	Check, tighten or replace inlet line	
	Air in hydraulic system	Cycle lift cylinders and bucket cylinders	
	Oil level too low	Add oil as required	
Excessive movement at pivots	Worn bushings and/or pins	Replace bushings and/or pins	
Pump noisy	Inlet line restricted or leaking	Check for air leaks, restrictions or collapsed hose	
		Tighten or replace hose	
		Clean filter if necessary	
	Oil level too low	Add oil as required	
Pump worn or damaged	Repair or replace pump		
Oil leaks	Damaged fitting or hoses	Replace damaged parts	
	Loose connections	Tighten fittings	
	Worn or damaged o-ring wiper seal in cylinder rod end	Install a seal repair kit	

Problem	Possible Cause	Remedy
Insufficient lift capacity	Improper hydraulic pump operation	Repair or replace pump
	Load is greater than boom lift capacity	Check loader specifications
	Internal boom cylinder leakage	Replace any worn parts and install a seal repair kit
	Improper hydraulic valve operation	Repair or replace valve
Slow leak down	Worn control valve	Have authorized dealer replace seals
	Worn cylinder piston seals	
Excessive wear on bottom of bucket and wear pads	Float position not used while operating loader	Use float position provided on valve
Hydraulic cylinders inoperative	Hose from control valve improperly connected	Refer to plumbing diagrams
Pump operating continually on closed center tractor hydraulics system	Tractor control valve relief stuck open	See your service manual for proper adjustment
	Incorrect Auxiliary Valve	Check with loader dealer for proper valve application
	Hydraulic control valve set to low	Adjust valve in accordance with manual
Loader lift and bucket tilt controls do not work according to decal	Hoses improperly connected	Refer to plumbing diagrams and correct hose connections
Valve noisy and/or hot	Open center control valve on closed center tractor	Replace relief valve with closed center plug and plug the power beyond adapter on valve
Tractor loads/pump squeals	Closed center control valve on open center tractor	Install open center plug on optional valve
		Replace closed center plug with relief and install short plug in place of the power beyond adapter

Maintenance

Lubrication

Lubricate tractor hydraulic unit as indicated in tractor operator's manual. Keep bushings on lift arm pivots and cylinders well lubricated. Use high-grade lithium grease every 8 hours of operation.

NOTE: Frequent greasing will prevent contaminants from migrating between the pins and bushings

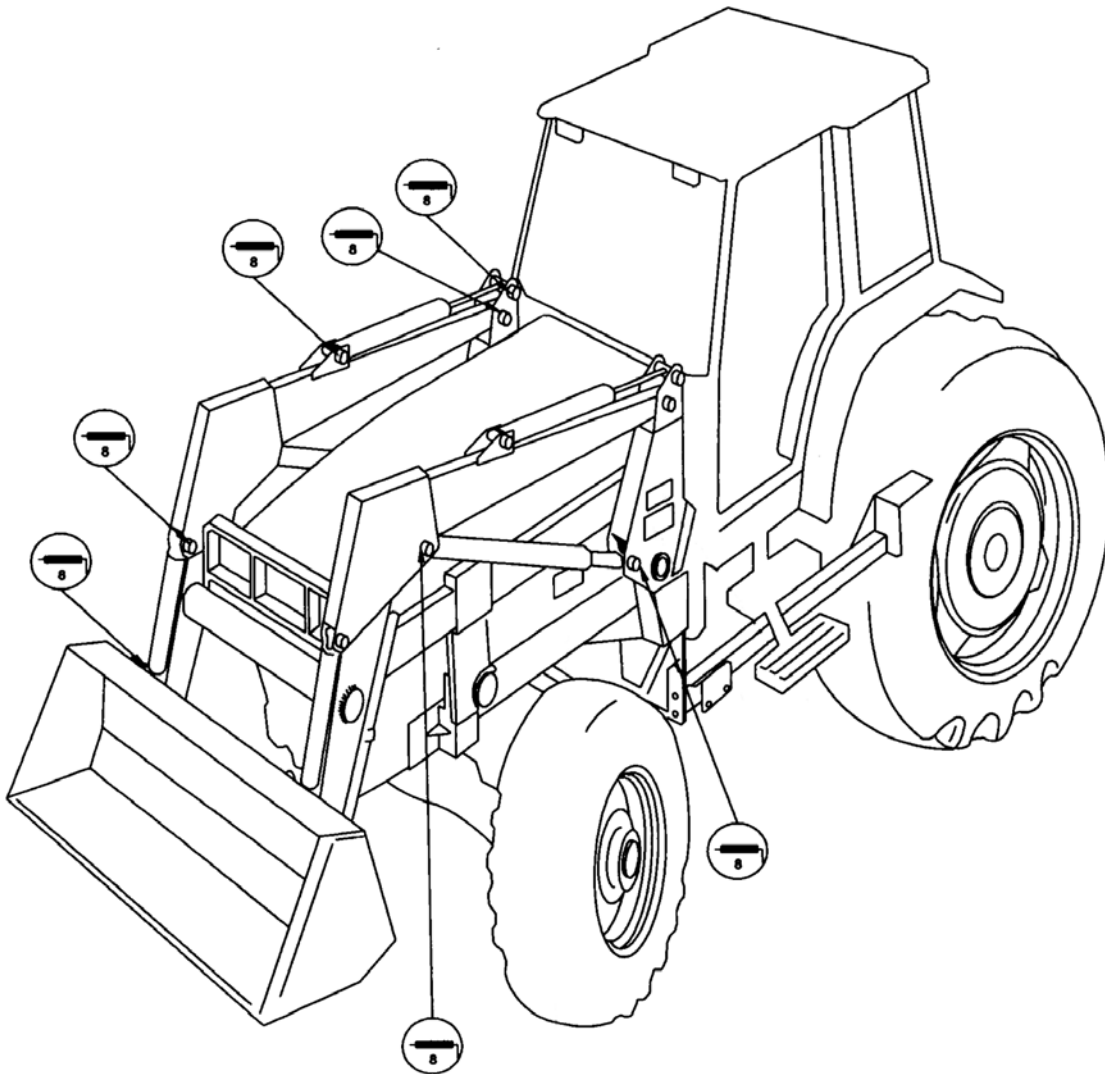

Bolt Torque

Checking Bolt Torque

The tables shown below give correct torque values for various bolts and hex bolts. Tighten all bolts to the torques specified in chart unless otherwise noted. Check tightness of bolts periodically, using bolt torque chart as a guide. Replace hardware with the same strength bolt.

Standard Bolt Torque						
Bolt Size (in)	Grade 2		Grade 5		Grade 8	
	Torque		Torque		Torque	
	ft-lb	NM	ft-lb	NM	ft-lb	NM
0.25	6	7	8	11	12	16
0.313	11	15	17	23	25	33
0.375	20	27	31	41	44	60
0.438	32	43	49	66	70	95
0.5	49	66	76	103	106	144
0.563	70	95	109	148	153	207
0.625	97	131	150	203	212	287
0.75	144	195	266	360	376	509
0.875	166	225	430	583	606	821
1	250	339	644	873	909	1232
1.125	354	480	795	1077	1288	1745
1.25	500	678	1120	1518	1817	2462
1.375	655	887	1470	1992	2382	3228
1.5	870	1179	1950	2642	3161	4283

Metric Bolt Torque								
Bolt Size (mm)	Class 5.6		Grade 8.8		Grade 10.9		Grade 12.9	
	Torque		Torque		Torque		Torque	
	ft-lb	NM	ft-lb	NM	ft-lb	NM	ft-lb	NM
6	3.1	4.3	7.3	9.9	10.3	14	12.1	16.5
8	7.7	10.5	17.7	24	25	34	29	40
10	15	21	35	48	49	67	59	81
12	26	36	61	83	86.2	117	103	140
14	42	58	97	132	136	185	162	220
16	64	88	147	200	210	285	250	340
18	89	121	202	275	287	390	346	470
20	126	171	287	390	405	550	486	660
22	169	230	390	530	549	745	656	890
24	217	295	497	675	708	960	840	1140
27	320	435	733	995	1032	1400	1239	1680
30	435	590	995	1350	1401	1900	1681	2280
33	590	800	1349	1830	1902	2580	2278	3090
36	759	1030	1740	2360	2441	3310	2935	3980
39	988	1340	2249	3050	3163	4290	3798	5150

Sub Frame Assembly

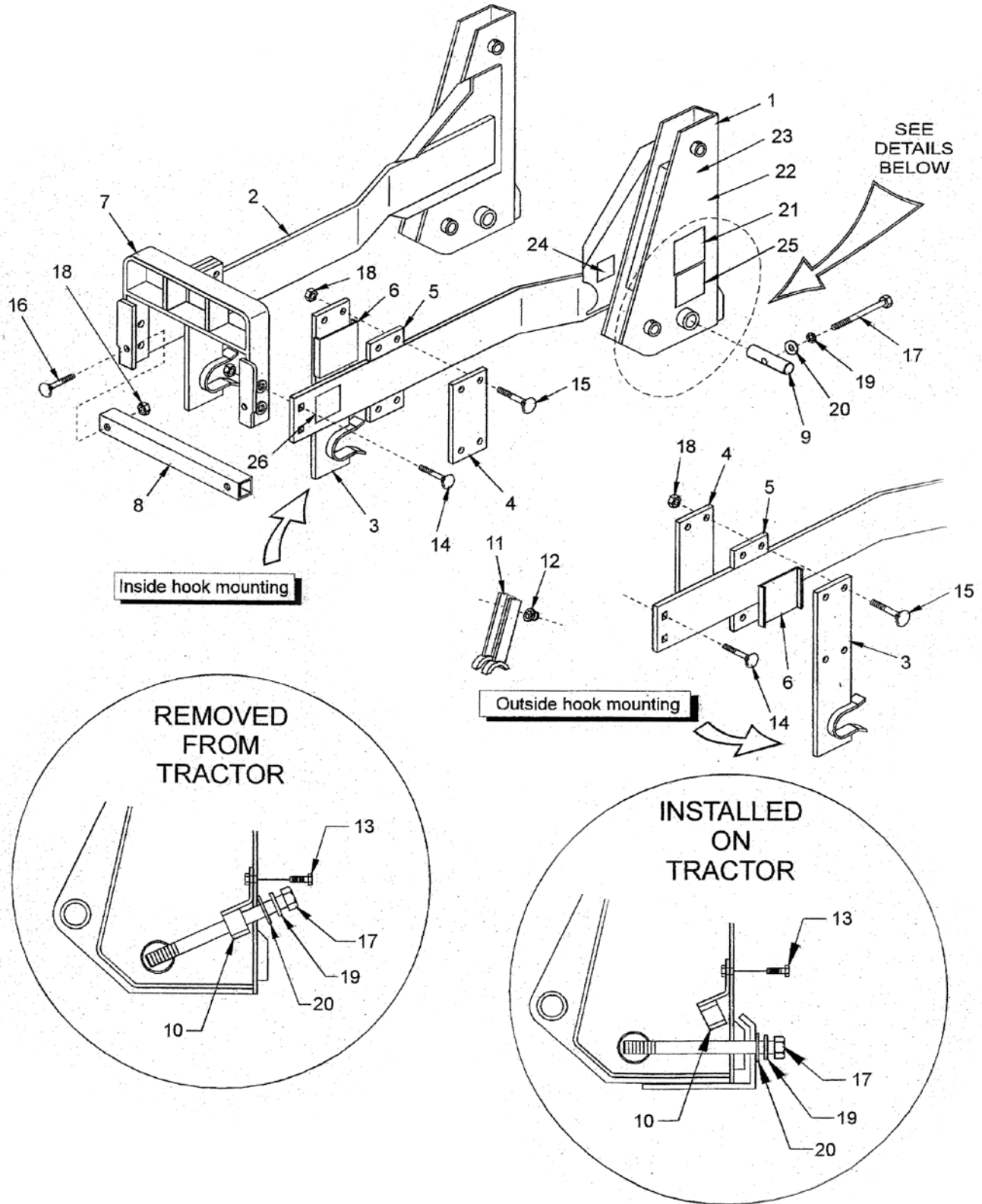

Item	Part #	Description	Qty 495	Qty S495
1	31607	495 Sub Frame Weldment Left	1	
2	31606	495 Sub Frame Weldment Right	1	
1	31611	495 S Sub Frame Weldment Left		1
2	31610	495 S Sub Frame Weldment Right		1
3	113253	Hook Weldment	2	2
4	112747	Plate Clamp	2	2
5	112746	Spacer Block	4	4
6	112748	Shim	2	2
7	112663	Cross Member Weldment	1	1
8	112668	Tube Cross Member	1	1
9	112642	Shaft Pivot 1.75 Dia x 5.50 Lg	2	2
10	113281	Bolt Retainer Weldment	2	2
11	113746	Loader Lift Lock Weldment	2	2
12	812717	Grommet 0.375 ID x 1.00 gr5 PI	2	2
13	812026	Bolt Hex 0.313nc x 1.00 gr5 PI	2	2
14	812882	Bolt Car. 0.625nc x 2.50 gr5 PI	4	4
15	812944	Bolt Car. 0.625nc x 3.00 gr5 PI	8	8
16	84127	Bolt Car. 0.625nc x 3.50 gr5 PI	2	2
17	812939	Bolt Hex 0.875nc x 10.00 gr8 PI	2	2
18	81967	Nut Lock (Nylon) 0.625nc gr8 PI	14	14
19	81723	Washer Lock 0.875 PI	2	2
20	112730	Washer Boot	2	2
21	112812	*Decal - General Caution	2	2
22	113385	*Decal - 495 x 1.40	2	2
23	112615	*Decal - S x 1.40		2
24	112982	*Decal - Lift Lock Instructions	2	2
25	112983	*Decal - Warning Overhead Hazard	2	2
26	113474	*Decal - Cross Member Caution	2	2

*Part of decal replacement kit X1245

Main Frame Assembly

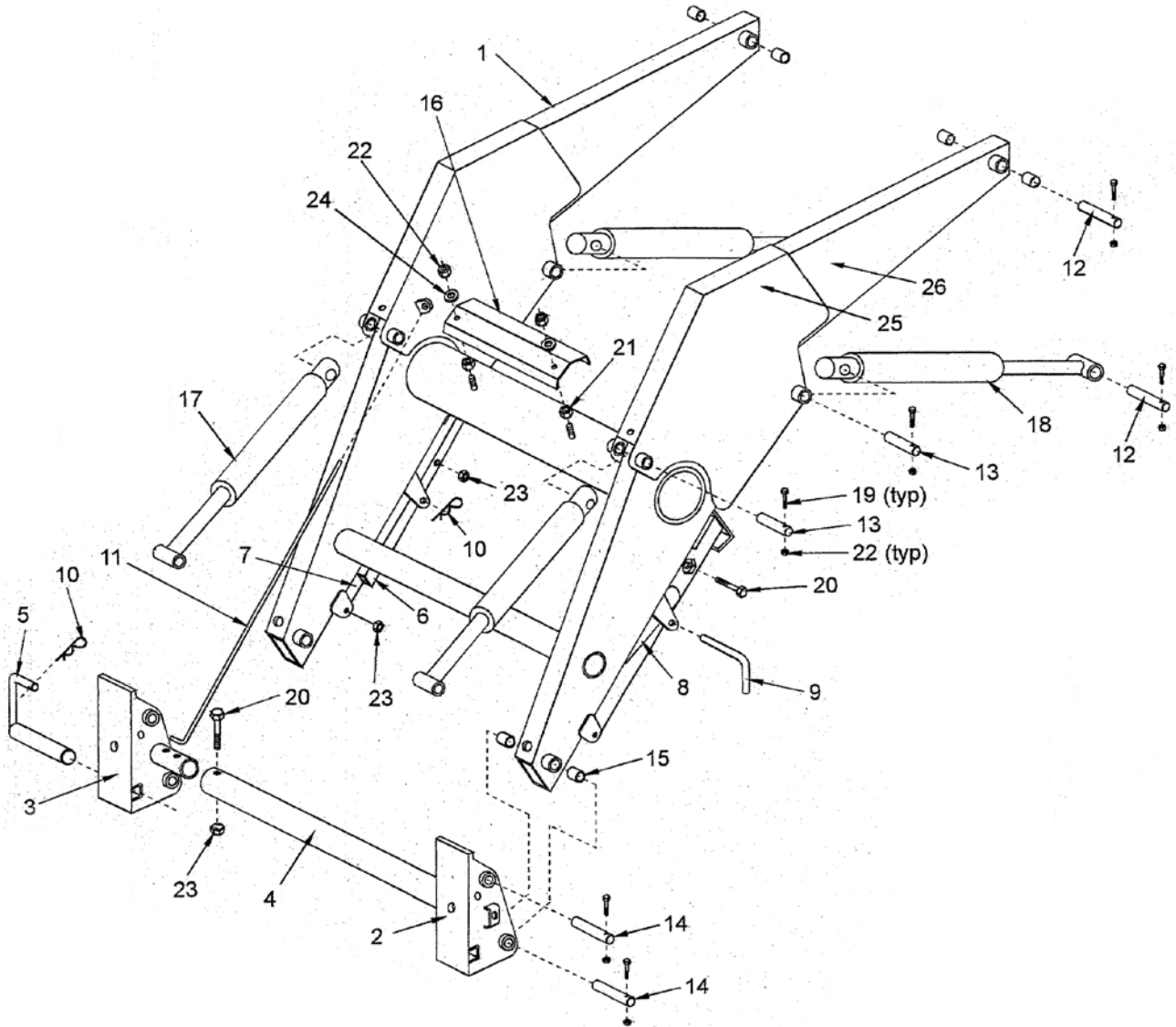

Item	Part #	Description	Qty 495	Qty 495S
1	31605	495 Main Frame Weldment	1	-
	31609	S495 Main Frame Weldment	-	1
2	24296	Quick Attach Weldment Left	1	1
3	24297	Quick Attach Weldment Right	1	1
4	112798	Tube Cross Qtach	1	1
5	108827	Pin Weldment	2	2
6	113433	Stand Weldment	2	2
7	113114	Strap Stand	2	2
8	24329	Wrench Mounting	1	1
9	110907	Pin 0.625 Dia Stand	2	2
10	12779	Hair Pin Clip #9 Western Wire	5	5
11	11325	Leveling Rod (54.0")	1	1
12	112954	Pin 1.25 Dia. x 6.75 Long	4	4
13	112955	Pin 1.25 Dia. x 5.00 Long	4	4
14	112800	Pin Qtach	4	4
15	113766	Bushing 1.25 ID x 1.50 OD x 1.375 Long	8	8
16	24242	Tube Cover	1	1
17	24458	2.5 Dia. x 20.63 Bucket Cylinder	2	2
18	24476	2.5 Dia. x 20.50 Lift Cylinder	2	2
19	81581	Bolt Hex 0.375nc x 2.50 Gr5 PI	16	16
20	81669	Bolt Hex 0.625nc x 3.50 Gr5 PI	4	4
21	81592	Nut Hex 0.375nc x 3.50 Gr5 PI	4	4
22	81344	Nut Lock (nylon) 0.375nc GrB PI	20	20
23	81967	Nut Lock (nylon) 0.625nc GrB PI	6	6
24	81570	Washer Flat Std 0.375 Hs PI	4	4
25	112614	*Decal - Allied x 1.75	2	2
26	52281-000	*Bright Orange Scotchal #72368	10 ft	10 ft
27	113488	*Decal - Quick Attach Instruction	2	2

*Part of decal replacement kit X1245

Hydraulic Plumbing Assembly

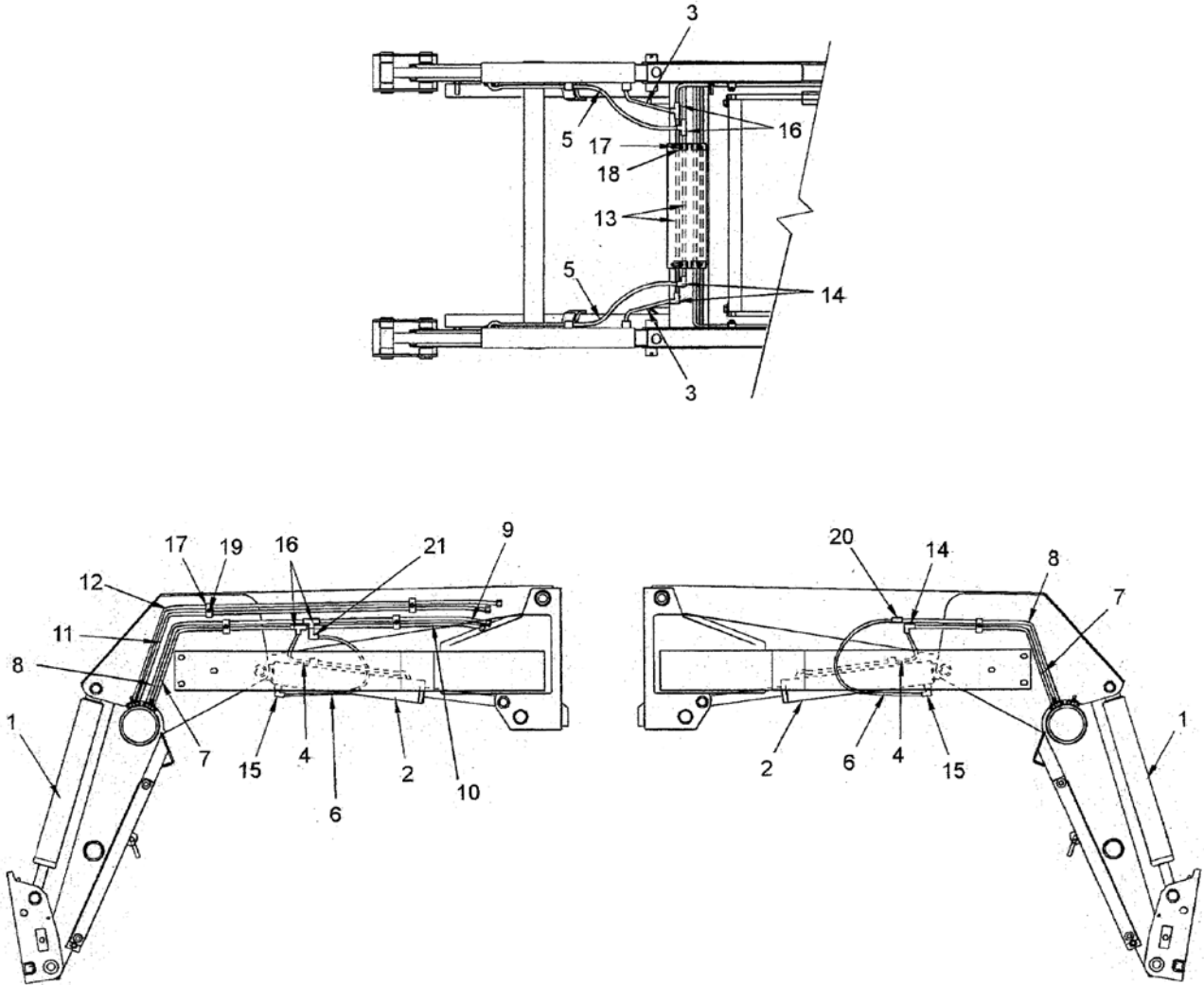

Item	Part #	Description	Qty
1	24458	2.5 Dia. x 20.63 Cyl. Assy. Bucket	2
2	24476	2.5 Dia. x 20.63 Cyl. Assy. Lift	2
3	812973	3/8 x 12" Hose 3/4 Morb x 3/4 Swfjic	2
4	811572	3/8 x 15" Hose 3/4 Morb x 3/4 Swfjic	2
5	812703	3/8 x 22" Hose 3/4 Morb x 3/4 Swfjic	2
6	812697	3/8 x 24" Hose 3/4 Morb x 3/4 Swfjic	2
7	113346	Tubing - Lift Cyl. Bottom Raise	1
8	113347	Tubing - Lift Cyl. Top Drop	1
9	113031	Tubing - Lift Cyl. Common (23.0")	1
10	112937	Tubing - Lift Cyl. Common (31.0")	1
11	113348	Tubing - Bucket Cyl. Bottom Rollbk	1
12	113349	Tubing - Bucket Cyl. Top Dump	1
13	112837	Tubing - Bucket Cyl. Cross Tube	2
14	812128	Elbow 90 3/4 Mjic x 3/4 Mjic	4
15	811414	Elbow 90 3/4 Morb x 3/4 Mjic	2
16	812069	Tee 3/4 Mjic	4
17	11362	Clip Pipe Std	11
18	81592	Nut Hex 0.375nc Gr2 Pl	4
19	81344	Nut Lock (nylon) 0.375nc Pl	9

Assembly

Hydraulic Cylinder Assembly

Item	Description	Bucket Cylinders		Lift Cylinders	
	Diameter	2.50"	3.00"	2.50"	3.00"
	Length of Stroke	20.63"	20.63"	20.63"	20.63"
	Retracted Length	33.00"	33.00"	38.00"	38.00"
	Extended Length	53.63"	53.63"	53.63"	53.63"
	Cylinder Assembly No.	24458	24407	24476	24479
	Seal Kit No.	X1110	X9946	X1110	X9947
	Shaft Diameter	1.50"	1.50"	1.50"	1.75"
1	Head Plate No.	24455	24856	24455	23791
2	Shaft Weldment No.	113120	113120	113218	113123
3	Cylinder Tube Weld't No.	24459	24409	24477	24480
4	Piston Half (wide) No.	113217	112862	113217	112862
5	Piston Half (narrow) No.	113216	112863	113216	112863
6	Self-Locking Nut No.	810457	810457	810457	810457
7	Shaft Bushing No.	113766	113766	113766	113766

1. Bucket cylinder shown.
2. All cylinder seals are contained in corresponding seal kit.

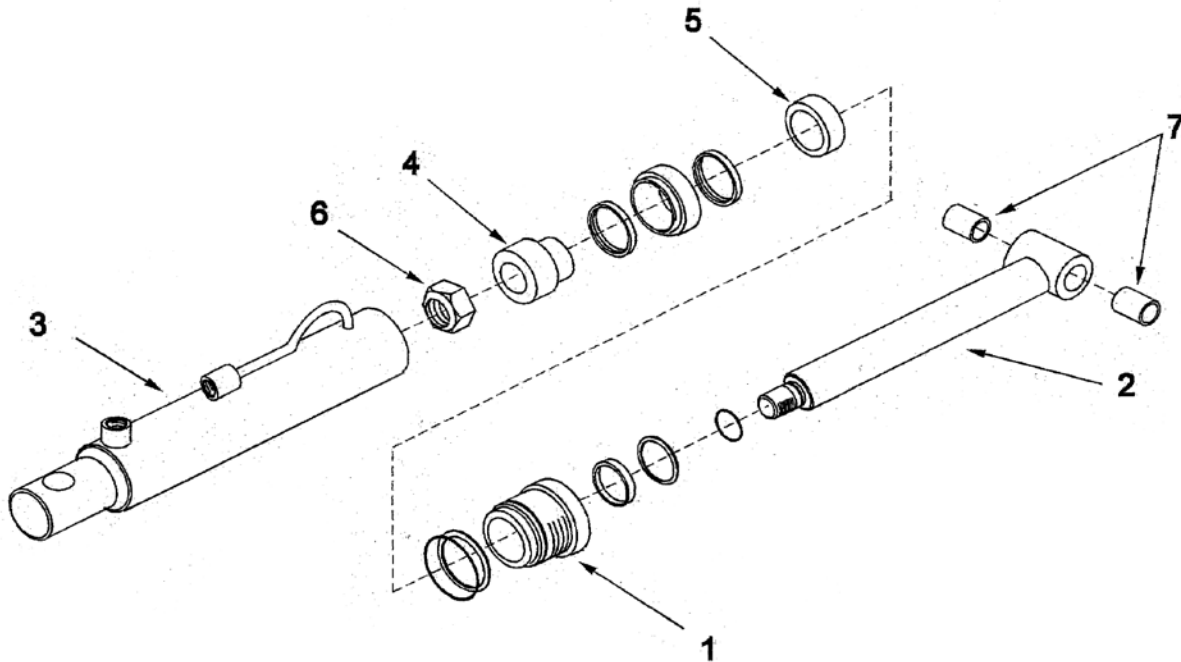

CAUTION

Maximum pressure - 2750 psi

Pre-delivery Check List

Before delivering this equipment please complete the following check list.

- 1. The loader has been installed using the appropriate mounting kit for the tractor and loader.
- 2. The hydraulic system installed is appropriate for the tractor and loader.
- 3. The loader is properly installed.
- 4. All bolts are tightened to the torque specifications shown in the torque chart.
- 5. All safety decals are readable.
- 6. The loader has been tested and operates properly.
- 7. The operator's manual has been delivered to the owner who has been instructed on the safe and proper use of the loader.

Dealer's Signature:

This check list is to remain in this owner's manual and is the responsibility of the dealer to complete it before delivery to the customer.

Allied by Farm King Limited Warranty

This document limits your warranty rights.

Base Limited Warranty

Buhler Industries Inc. provides this warranty only to original retail purchasers of its product. Buhler Industries Inc. warrants to such purchasers that all Buhler Industries Inc. manufactured parts and components used and serviced as provided for in the Operator's Manual shall be free from defects in materials and workmanship for a period following delivery to the original retail purchaser of 12 months (80 days for commercial applications). This limited warranty applies only to those parts and components manufactured by Buhler Industries Inc. Parts and components manufactured by others are subject to their manufacturer's warranties, if any.

Buhler Industries Inc. will fulfill this limited warranty by, at its option, repairing or replacing any covered part that is defective or is the result of improper workmanship, provided that the part is returned to Buhler Industries Inc. within thirty (30) days of the date that such defect or improper workmanship is, or should have been, discovered. Buhler Industries Inc. reserves the right to either inspect the product at the buyer's location or have it returned to the factory for inspection. Parts must be returned through the selling representative and the buyer must prepay transportation charges.

Buhler Industries Inc. will not be responsible for repairs or replacements that are necessitated, in whole or part, by the use of parts not manufactured by or obtained from Buhler Industries Inc. Under no circumstances are component parts warranted against normal wear and tear. There is no warranty on product pump seals, product pump bearings, rubber product hoses, pressure gauges, or other components that require replacement as part of normal maintenance. Also: Buckets and Bucket Tines carry no warranty, Bent Spears carry no warranty, Snowblower Fan Shafts carry no warranty, Mower Blades carry no warranty, Portable Auger Parts Have Two (2) Year Warranty, Loader Parts Have Two (2) Year Warranty. The purchaser is solely responsible for determining suitability of goods sold. This warranty is expressly in lieu of all other warranties expressed or implied. Buhler Industries Inc. will in no event be liable for any incidental or consequential damages whatsoever. Nor for any sum in excess of the price received for the goods for which liability is claimed.

Repair Parts Limited Warranty

Buhler Industries Inc. warrants Allied by Farm King replacement parts purchased after the expiration of the Buhler Industries Inc. Limited Warranty, and used and serviced as provided for in the Operator's Manual, to be free from defects in materials or workmanship for a period of thirty (30) days from the invoice date for the parts. Buhler Industries Inc. will fulfill this limited warranty by, at its option, repairing or replacing any covered part that is defective or is the result of improper workmanship, provided that the part is returned to Buhler Industries Inc. within thirty (30) days of the date that such defect or improper workmanship is, or should have been, discovered. Such parts must be shipped to Buhler Industries Inc. at the purchaser's expense.

What is Not Covered

Under no circumstances does this limited warranty cover any components or parts that have been subject to the following: negligence; alteration or modification not approved by Buhler Industries Inc.; misuse; improper storage; lack of reasonable and proper maintenance, service, or repair; normal wear; damage from failure to follow operating instructions; accident; and/or repairs that have been made with parts other than those manufactured, supplied, and or authorized by Buhler Industries Inc.

Authorized Dealer and Labor Costs

Repairs eligible for labor under this limited warranty must be made by Buhler Industries Inc. or an authorized Allied by Farm King dealer. Buhler Industries Inc. retains the exclusive discretion to determine whether it will pay labor costs for warranty repairs or replacements, and the amount of such costs that it will pay and the time in which the repairs will be made. If Buhler Industries Inc. determines that it will pay labor costs for warranty work, it will do so by issuing a credit to the dealer's or distributor's account. Buhler Industries Inc. will not approve or pay invoices sent for repairs that Buhler Industries Inc. has not previously approved. Warranty service does not extend the original term of this limited warranty.

Warranty Requirements

To be covered by warranty, each Allied by Farm King new product must be registered with Buhler Industries Inc. within thirty (30) days of delivery to original retail purchaser. If the customer decides to purchase replacement components before the warranty disposition of such components is determined, Buhler Industries Inc. will bill the customer for such components and then credit the replacement invoice for those components later determined to be covered by this limited warranty. Any such replacement components that are determined not be covered by this limited warranty will be subject to the terms of the invoice and shall be paid for by the purchaser.

Warranty Claims:

Warranty requests must be prepared on Buhler Industries Inc. Warranty Claim Forms with all requested information properly completed. Warranty Claims must be submitted within a thirty (30) day period from date of failure repair.

Warranty Labor:

Any labor subject to warranty must be authorized by Buhler Industries Inc. The labor rate for replacing defective parts, where applicable, will be credited at 100% of the dealer's posted shop rate.

Exclusive Effect of Warranty and Limitation of Liability

TO THE EXTENT PERMITTED BY LAW, BUHLER INDUSTRIES INC. DISCLAIMS ANY WARRANTIES, REPRESENTATIONS, OR PROMISES, EXPRESS OR IMPLIED, AS TO THE QUALITY, PERFORMANCE, OR FREEDOM FROM DEFECT OF THE COMPONENTS AND PARTS COVERED BY THIS WARRANTY AND NOT SPECIFICALLY PROVIDED FOR HEREIN.

TO THE EXTENT PERMITTED BY LAW, BUHLER INDUSTRIES INC. DISCLAIMS ANY IMPLIED WARRANTIES OF MERCHANTABILITY AND FITNESS FOR A PARTICULAR PURPOSE ON ITS PRODUCTS COVERED HEREIN, AND DISCLAIMS ANY RELIANCE BY THE PURCHASER ON BUHLER INDUSTRIES INC.'S SKILL OR JUDGMENT TO SELECT OR FURNISH GOODS FOR ANY PARTICULAR PURPOSE. THE PURCHASER'S ONLY AND EXCLUSIVE REMEDIES IN CONNECTION WITH THE BREACH OR PERFORMANCE OF ANY WARRANTY ON PRODUCTS MANUFACTURED BY BUHLER INDUSTRIES INC. ARE THOSE SET FORTH HEREIN. IN NO EVENT SHALL BUHLER INDUSTRIES INC. BE LIABLE FOR INCIDENTAL OR CONSEQUENTIAL DAMAGES (INCLUDING, BY WAY OF EXAMPLE ONLY AND NOT LIMITATION, LOSS OF CROPS, LOSS OF PROFITS OR REVENUE, OTHER COMMERCIAL LOSSES, INCONVENIENCE, OR COST OF REPLACEMENT OF RENTAL EQUIPMENT). IN NO EVENT SHALL Allied by Farm King'S CONTRACT OR WARRANTY LIABILITY EXCEED THE PURCHASE PRICE OF THE PRODUCT.

(Note that some provinces or states do not allow limitations on how long an implied warranty lasts or the exclusion or limitation of incidental or consequential damages, so the above limitations and exclusion may not apply to you.) This warranty gives you specific legal rights and you may also have other rights, which vary from province to province or state to state.

Buhler Industries Inc. neither assumes nor authorizes any person or entity, including its selling representatives, to assume any other obligations or liability in connections with the sale of covered equipment, or to make any other warranties, representations, or promises, express or implied, as to the quality, performance, or freedom from defect of the components and parts covered herein. No one is authorized to alter, modify, or enlarge this limited warranty, or its exclusions, limitations and reservations.

Corrections of defects and improper workmanship in the manner, and for the applicable time periods, provided for herein shall constitute fulfillment of all responsibilities of Buhler Industries Inc. to the purchaser, and Buhler Industries Inc. shall not be liable in negligence, contract, or on any other basis with respect to the subject equipment.

This limited warranty is subject to any existing conditions of supply which may directly affect Buhler Industries Inc.'s ability to obtain materials or manufacture replacement parts.

Buhler Industries Inc. reserves the right to make improvements in design or changes in specifications to its products at anytime, without incurring any obligation to owners of units previously sold.

Government Legislation:

Warranty terms and conditions are subject to provincial or state legislation.

Important Note: This warranty does not apply to rentals.

www.farm-king.com



1330 43rd Street NW
Fargo, North Dakota USA 58102
Ph.: 701.282.7014 | Fax: 701.282.5865
E-mail: info@buhler.com
www.farm-king.com

Equipment shown is subject to change without notice.
©2011 BuhlerTrading Inc. Printed in USA. TSX:BUI

bühler | a division of Buhler Industries Inc.